

No. 744,401.

PATENTED NOV. 17, 1903.

H. POLAK.
WHIP.

APPLICATION FILED MAR. 2, 1903.

NO MODEL.

FIG. 1.

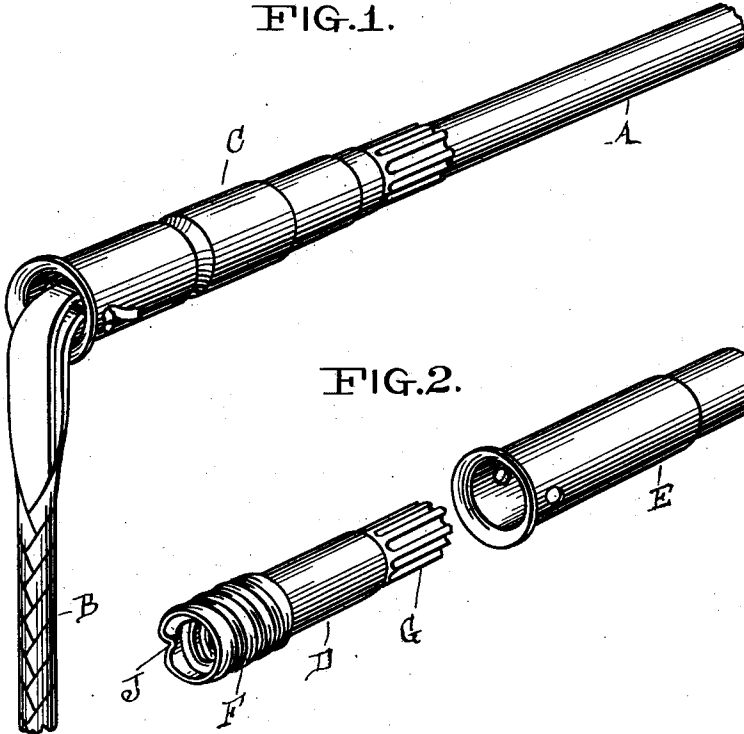

FIG. 2.

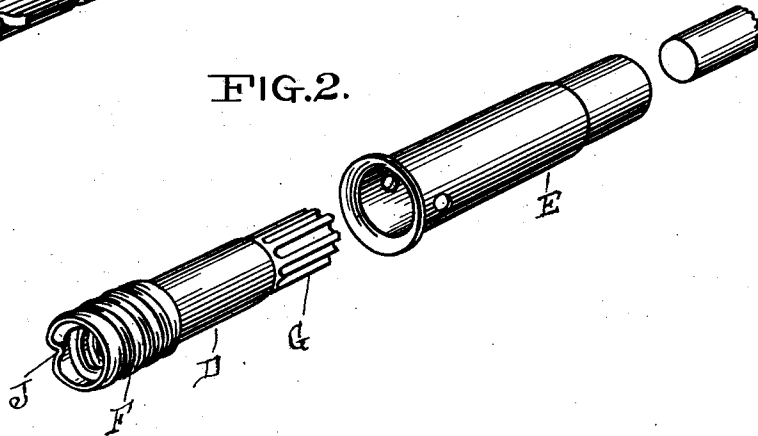
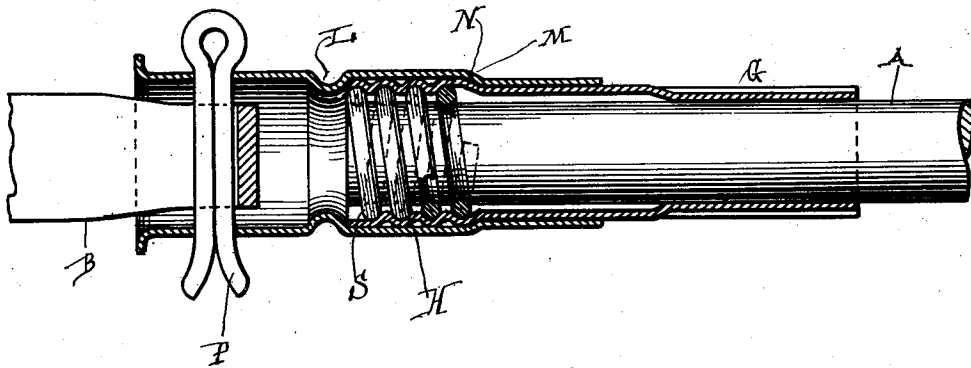

FIG. 3.



WITNESSES:

P. F. Smith
Geo. W. Ketchum

INVENTOR

Henry Polak
BY *Hubert W. Smith*
ATTORNEY

UNITED STATES PATENT OFFICE.

HENRY POLAK, OF BROOKLYN, NEW YORK.

WHIP.

SPECIFICATION forming part of Letters Patent No. 744,401, dated November 17, 1903.

Application filed March 2, 1903. Serial No. 145,656. (No model.)

To all whom it may concern:

Be it known that I, HENRY POLAK, a citizen of the United States, residing at 23 Russell street, in the borough of Brooklyn, county of Kings, and State of New York, have invented a new and useful Improvement in Whips, of which the following is a specification.

My invention relates particularly to a novel device for connecting the lash with what is known as the "stock" or "handle," the object being to provide a simple, economical, and effective attachment between the rigid and flexible parts of the implement.

Referring to the accompanying drawings, which form a part of this specification, Figure 1 shows a perspective view of a portion of the completed article. Fig. 2 is a perspective view of the different members of my improved attachment detached one from another to show their relation. Fig. 3 is a longitudinal section to a larger scale of the various parts.

In the drawings, A represents the stock or handle of a whip, and B the lash. At C, I show my improved attachment for connecting these parts to one another. This attachment consists principally of two parts D and E. The part D fits onto the stock or handle A and has a screw F secured and locked within it to afford means for gripping the handle tightly. The part D is provided with parallel corrugated ridges G, which operate to grasp the stock more firmly. The screw F, employed to grasp the outer end of the stock or handle A, is formed of spiral spring S, set into a corresponding interior spiral groove H. When the spring S has been placed in position by inserting from the outer end, a notch J is formed in the part D, which serves to lock

the spiral spring in position. The part E fits over the part D, and a ring or annular portion L holds it in place, while at the same time permitting a turning movement of the two parts D and E one on the other. This part of my invention is formed as follows: When the part E has been slipped over the part D and has reached the position shown in Fig. 3, the shoulder M of the part E, fitting up against the shoulder N of the part D, the depression or annular portion L is formed in the part E. By these means the parts D and E are locked together longitudinally, although they will turn easily on each other.

A pin P is provided for holding the lash B to the attachment. By means of this the lash can be removed and renewed.

The turning movement of the part E on the part D prevents the lash from wrapping itself around the handle.

Having thus described my invention, the following is what I claim as new therein and desire to secure by Letters Patent:

In a whip the combination of the lash and the handle, with means for attaching these parts one to the other consisting of the part D having corrugated ridges G for securing same to handle, the spiral groove H within which is located the spiral spring S, and a shoulder N, with the part E having shoulders M and L, and a pin P for the attachment of the lash, all arranged substantially as and for the purposes set forth.

HENRY POLAK.

Witnesses:

HERBERT KNIGHT,
R. F. LOWNEK.