



(86) **Date de dépôt PCT/PCT Filing Date:** 2014/07/07  
 (87) **Date publication PCT/PCT Publication Date:** 2016/01/14  
 (85) **Entrée phase nationale/National Entry:** 2016/11/08  
 (86) **N° demande PCT/PCT Application No.:** US 2014/045535  
 (87) **N° publication PCT/PCT Publication No.:** 2016/007119

(51) **Cl.Int./Int.Cl. E21B 33/12** (2006.01),  
**E21B 33/128** (2006.01)  
 (71) **Demandeur/Applicant:**  
HALLIBURTON ENERGY SERVICES, INC., US  
 (72) **Inventeurs/Inventors:**  
MURPHREE, ZACHARY RYAN, US;  
FRIPP, MICHAEL LINLEY, US;  
WALTON, ZACHARY WILLIAM, US;  
SMITH, CHARLES TIMOTHY, US  
 (74) **Agent:** NORTON ROSE FULBRIGHT CANADA  
LLP/S.E.N.C.R.L., S.R.L.

(54) **Titre : OUTILS EN FOND DE PUITS COMPRENANT DES ELEMENTS D'ETANCHEITE HYDRO-DEGRADABLES**  
 (54) **Title: DOWNHOLE TOOLS COMPRISING AQUEOUS-DEGRADABLE SEALING ELEMENTS**

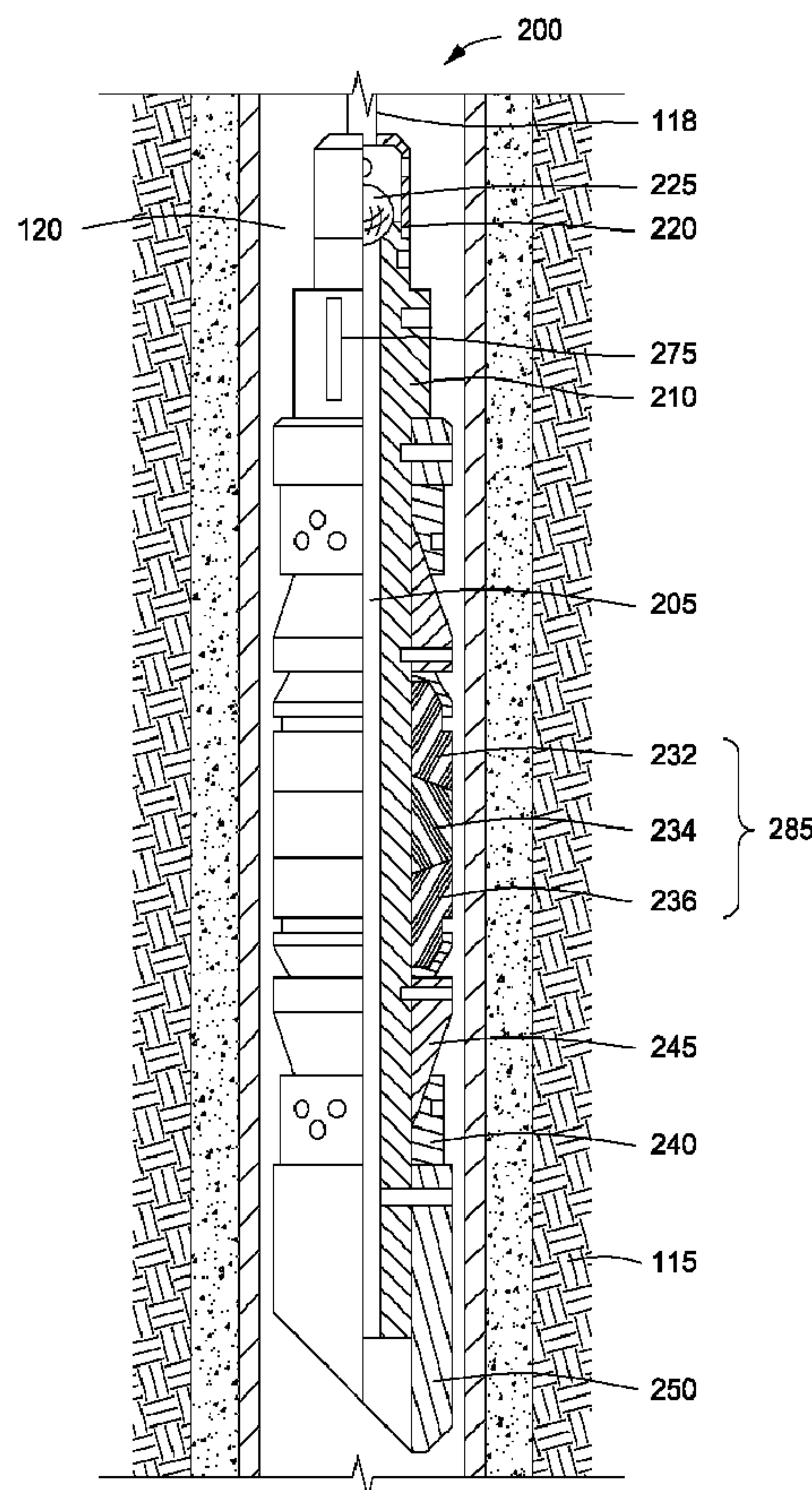

FIG. 2

(57) **Abrégé/Abstract:**

The present disclosure generally relates to downhole tools comprising aqueous-degradable sealing elements and, more specifically, to downhole tools comprising a body and an aqueous-degradable sealing element, wherein at least a portion of the

**(57) Abrégé(suite)/Abstract(continued):**

body is also degradable upon exposure to a wellbore environment. A downhole tool that includes a body, wherein at least a portion of the body is degradable when exposed to a wellbore environment; and at least one aqueous-degradable sealing element composed of an aqueous-degradable elastomer, wherein the aqueous-degradable sealing element degrades when exposed to an aqueous fluid in the wellbore environment.

(12) INTERNATIONAL APPLICATION PUBLISHED UNDER THE PATENT COOPERATION TREATY (PCT)

(19) World Intellectual Property  
Organization  
International Bureau(10) International Publication Number  
**WO 2016/007119 A1**(43) International Publication Date  
14 January 2016 (14.01.2016)

- (51) **International Patent Classification:**  
*E21B 33/12* (2006.01)    *E21B 33/128* (2006.01)
- (21) **International Application Number:**  
PCT/US2014/045535
- (22) **International Filing Date:**  
7 July 2014 (07.07.2014)
- (25) **Filing Language:** English
- (26) **Publication Language:** English
- (71) **Applicant:** HALLIBURTON ENERGY SERVICES, INC. [US/US]; 3000 N. Sam Houston Parkway E., Houston, Texas 77032-3219 (US).
- (72) **Inventors:** MURPHREE, Zachary Ryan; 6550 Shady Brook Lane #516, Dallas, Texas 75206 (US). FRIPP, Michael Linley; 3826 Cemetery Hill Rd., Carrollton, Texas 75007 (US). WALTON, Zachary William; 2204 Southern Ct., Carrollton, Texas 75006 (US). SMITH, Charles Timothy; 4240 Private Road 5079, McKinney, Texas 75071 (US).
- (74) **Agents:** KAISER, Iona et al.; McDermott Will & Emery LLP, 500 North Capitol Street, N.W., Washington, District of Columbia 20001 (US).
- (81) **Designated States** (*unless otherwise indicated, for every kind of national protection available*): AE, AG, AL, AM, AO, AT, AU, AZ, BA, BB, BG, BH, BN, BR, BW, BY, BZ, CA, CH, CL, CN, CO, CR, CU, CZ, DE, DK, DM, DO, DZ, EC, EE, EG, ES, FI, GB, GD, GE, GH, GM, GT, HN, HR, HU, ID, IL, IN, IR, IS, JP, KE, KG, KN, KP, KR, KZ, LA, LC, LK, LR, LS, LT, LU, LY, MA, MD, ME, MG, MK, MN, MW, MX, MY, MZ, NA, NG, NI, NO, NZ, OM, PA, PE, PG, PH, PL, PT, QA, RO, RS, RU, RW, SA, SC, SD, SE, SG, SK, SL, SM, ST, SV, SY, TH, TJ, TM, TN, TR, TT, TZ, UA, UG, US, UZ, VC, VN, ZA, ZM, ZW.
- (84) **Designated States** (*unless otherwise indicated, for every kind of regional protection available*): ARIPO (BW, GH, GM, KE, LR, LS, MW, MZ, NA, RW, SD, SL, SZ, TZ, UG, ZM, ZW), Eurasian (AM, AZ, BY, KG, KZ, RU, TJ, TM), European (AL, AT, BE, BG, CH, CY, CZ, DE, DK, EE, ES, FI, FR, GB, GR, HR, HU, IE, IS, IT, LT, LU, LV,

[Continued on next page]

(54) **Title:** DOWNHOLE TOOLS COMPRISING AQUEOUS-DEGRADABLE SEALING ELEMENTS

FIG. 2

(57) **Abstract:** The present disclosure generally relates to downhole tools comprising aqueous-degradable sealing elements and, more specifically, to downhole tools comprising a body and an aqueous-degradable sealing element, wherein at least a portion of the body is also degradable upon exposure to a wellbore environment. A downhole tool that includes a body, wherein at least a portion of the body is degradable when exposed to a wellbore environment; and at least one aqueous-degradable sealing element composed of an aqueous-degradable elastomer, wherein the aqueous-degradable sealing element degrades when exposed to an aqueous fluid in the wellbore environment.

**WO 2016/007119 A1** 

---

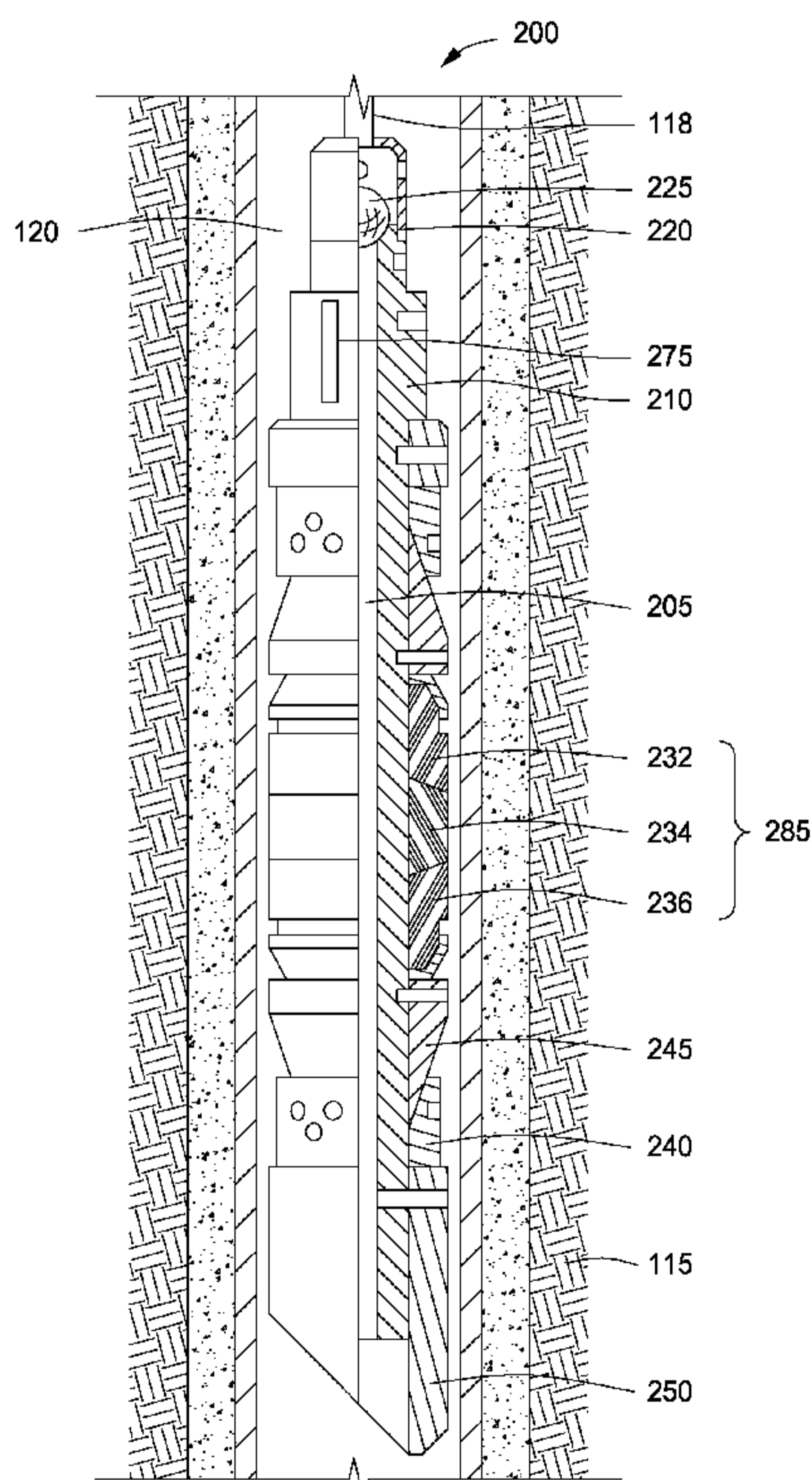
MC, MK, MT, NL, NO, PL, PT, RO, RS, SE, SI, SK, **Published:**  
SM, TR), OAPI (BF, BJ, CF, CG, CI, CM, GA, GN, GQ, — *with international search report (Art. 21(3))*  
GW, KM, ML, MR, NE, SN, TD, TG).

**Declarations under Rule 4.17:**

- *as to applicant's entitlement to apply for and be granted a patent (Rule 4.17(ii))*

## **DOWNHOLE TOOLS COMPRISING AQUEOUS-DEGRADABLE SEALING ELEMENTS**

### **BACKGROUND**

**[0001]** The present disclosure generally relates to downhole tools comprising aqueous-degradable sealing elements and, more specifically, to downhole tools comprising a body and an aqueous-degradable sealing element, wherein at least a portion of the body is also degradable upon exposure to a wellbore environment.

**[0002]** A variety of downhole tools are within a wellbore in connection with producing or reworking a hydrocarbon bearing subterranean formation. The downhole tool may comprise a wellbore zonal isolation device capable of fluidly sealing two sections of the wellbore from one another and maintaining differential pressure (*i.e.*, to isolate one pressure zone from another). The wellbore zonal isolation device may be used in direct contact with the formation face of the wellbore, with casing string, with a screen or wire mesh, and the like.

**[0003]** After the production or reworking operation is complete, the seal formed by the downhole tool must be broken and the tool itself removed from the wellbore. The downhole tool must be removed to allow for production or further operations to proceed without being hindered by the presence of the downhole tool. Removal of the downhole tool(s) is traditionally accomplished by complex retrieval operations involving milling or drilling the downhole tool for mechanical retrieval. In order to facilitate such operations, downhole tools have traditionally been composed of drillable metal materials, such as cast iron, brass, or aluminum. These operations can be costly and time consuming, as they involve introducing a tool string (*e.g.*, a mechanical connection to the surface) into the wellbore, milling or drilling out the downhole tool (*e.g.*, at least breaking the seal), and mechanically retrieving the downhole tool or pieces thereof from the wellbore to bring to the surface.

**[0004]** To reduce the cost and time required to mill or drill a downhole tool from a wellbore for its removal, degradable downhole tools have been developed. Traditionally, however, such degradable downhole tools have been designed only such that the degradable portion includes the tool body itself

and not any sealing element of the downhole tool. This is particularly evident because the degradable materials that have been proposed for use in forming a downhole tool body are often highly brittle and are physically or chemically incapable of exhibiting expansive or elastic properties necessary for a sealing element. Instead, the known degradable downhole tools may degrade such that it no longer provides the structural integrity necessary for achieving an effective seal with the non-degradable sealing element.

### **BRIEF DESCRIPTION OF THE DRAWINGS**

**[0005]** The following figures are included to illustrate certain aspects of the embodiments, and should not be viewed as exclusive embodiments. The subject matter disclosed is capable of considerable modifications, alterations, combinations, and equivalents in form and function, as will occur to those skilled in the art and having the benefit of this disclosure.

**[0006]** FIG. 1 illustrates a cross-sectional view of a well system comprising a downhole tool, according to one or more embodiments described herein.

**[0007]** FIG. 2 depicts an enlarged cross-sectional view of a downhole tool, according to one or more embodiments described herein.

**[0008]** FIG. 3 shows an enlarged cross-sectional view of a downhole tool in operation, according to one or more embodiments described herein.

### **DETAILED DESCRIPTION**

**[0009]** The present disclosure generally relates to downhole tools comprising aqueous-degradable sealing elements and, more specifically, to downhole tools comprising a body and an aqueous-degradable sealing element, wherein at least a portion of the body is also degradable upon exposure to a wellbore environment. As used herein, the term "degradable" and all of its grammatical variants (*e.g.*, "degrade," "degradation," "degrading," and the like) refers to the dissolution or chemical conversion of materials into smaller components, intermediates, or end products by at least one of solubilization, hydrolytic degradation, biologically formed entities (*e.g.*, bacteria or enzymes), chemical reactions, electrochemical processes, thermal reactions, or reactions induced by radiation. In some instances, the degradation of the material may be

sufficient for the mechanical properties of the material to reduce to a point that the material no longer maintains its integrity and, in essence, falls apart. The conditions for degradation are generally wellbore conditions where an external stimuli may be used to initiate or affect the rate of degradation. For example, the pH of the fluid that interacts with the material may be changed by introduction of an acid or a base. The term "wellbore environment" includes both naturally occurring wellbore environments and introduced materials into the wellbore.

**[0010]** Disclosed are various embodiments of a downhole tool including an aqueous-degradable sealing element capable of fluidly sealing two sections of a wellbore (which may be also referred to as "setting" the downhole tool). The downhole tool may have various setting mechanisms for fluidly sealing the sections of the wellbore with the sealing element including, but not limited to, hydraulic setting, mechanical setting, setting by swelling, setting by inflation, and the like. The downhole tool may be a well isolation device, such as a frac plug, a bridge plug, or a packer, a wiper plug, a cement plug, or any other tool requiring a sealing element for use in a downhole operation. Such downhole operations may include, but are not limited to, any type of fluid injection operation (*e.g.*, a stimulation/fracturing operation, a pinpoint acid stimulation, casing repair, and the like), and the like. In some embodiments, the downhole tool may comprise a body and at least one aqueous-degradable sealing element composed of an aqueous-degradable elastomer. The aqueous-degradable sealing element may degrade in a wellbore environment, such as upon contact with an aqueous fluid therein. As discussed in detail below, degradation of the aqueous-degradable sealing element may be accelerated, rapid, or normal, degrading anywhere from about 30 minutes to about 40 days from first contact with an aqueous fluid.

**[0011]** In some embodiments, at least a portion of the body itself may also be degradable upon exposure to the wellbore environment. The embodiments herein permit fluid sealing of two wellbore sections with a downhole tool having an aqueous-degradable sealing element that later degrades *in situ*, preferably without the need to mill or drill, and retrieve the downhole tool from the wellbore. In particular, the degradation of the aqueous-degradable sealing element results in failure of the sealing element to maintain differential pressure and form an effective seal. In such cases, the downhole

tool may drop into a rathole in the wellbore without the need for retrieval or may be sufficiently degraded in the wellbore so as to be generally indiscernible. It will be appreciated by one of skill in the art that while the embodiments herein are described with reference to a downhole tool, the aqueous-degradable sealing elements disclosed herein may be used with any wellbore operation equipment that may preferentially degrade upon exposure to aqueous fluids.

**[0012]** One or more illustrative embodiments disclosed herein are presented below. Not all features of an actual implementation are described or shown in this application for the sake of clarity. It is understood that in the development of an actual embodiment incorporating the embodiments disclosed herein, numerous implementation-specific decisions must be made to achieve the developer's goals, such as compliance with system-related, lithology-related, business-related, government-related, and other constraints, which vary by implementation and from time to time. While a developer's efforts might be complex and time-consuming, such efforts would be, nevertheless, a routine undertaking for those of ordinary skill in the art having benefit of this disclosure.

**[0013]** It should be noted that when "about" is provided herein at the beginning of a numerical list, the term modifies each number of the numerical list. In some numerical listings of ranges, some lower limits listed may be greater than some upper limits listed. One skilled in the art will recognize that the selected subset will require the selection of an upper limit in excess of the selected lower limit. Unless otherwise indicated, all numbers expressed in the present specification and associated claims are to be understood as being modified in all instances by the term "about." Accordingly, unless indicated to the contrary, the numerical parameters set forth in the following specification and attached claims are approximations that may vary depending upon the desired properties sought to be obtained by the exemplary embodiments described herein. At the very least, and not as an attempt to limit the application of the doctrine of equivalents to the scope of the claim, each numerical parameter should at least be construed in light of the number of reported significant digits and by applying ordinary rounding techniques.

**[0014]** While compositions and methods are described herein in terms of "comprising" various components or steps, the compositions and methods can also "consist essentially of" or "consist of" the various components and steps. When "comprising" is used in a claim, it is open-ended.



**[0015]** The use of directional terms such as above, below, upper, lower, upward, downward, left, right, uphole, downhole and the like are used in relation to the illustrative embodiments as they are depicted in the figures, the upward direction being toward the top of the corresponding figure and the downward direction being toward the bottom of the corresponding figure, the uphole direction being toward the surface of the well and the downhole direction being toward the toe of the well.

**[0016]** Referring now to **FIG. 1**, illustrated is an exemplary well system **110** for a downhole tool **100**. As depicted, a derrick **112** with a rig floor **114** is positioned on the earth's surface **105**. A wellbore **120** is positioned below the derrick **112** and the rig floor **114** and extends into subterranean formation **115**. As shown, the wellbore may be lined with casing **125** that is cemented into place with cement **127**. It will be appreciated that although **FIG. 1** depicts the wellbore **120** having a casing **125** being cemented into place with cement **127**, the wellbore **120** may be wholly or partially cased and wholly or partially cemented (*i.e.*, the casing wholly or partially spans the wellbore and may or may not be wholly or partially cemented in place), without departing from the scope of the present disclosure. Moreover, the wellbore **120** may be an open-hole wellbore. A tool string **118** extends from the derrick **112** and the rig floor **114** downwardly into the wellbore **120**. The tool string **118** may be any mechanical connection to the surface, such as, for example, wireline, slickline, jointed pipe, or coiled tubing. As depicted, the tool string **118** suspends the downhole tool **100** for placement into the wellbore **120** at a desired location to perform a specific downhole operation. As previously mentioned, the downhole tool **100** may be any type of wellbore zonal isolation device including, but not limited to, a frac plug, a bridge plug, a packer, a wiper plug, or a cement plug.

**[0017]** It will be appreciated by one of skill in the art that the well system **110** of **FIG. 1** is merely one example of a wide variety of well systems in which the principles of the present disclosure may be utilized. Accordingly, it will be appreciated that the principles of this disclosure are not necessarily limited to any of the details of the depicted well system **110**, or the various components thereof, depicted in the drawings or otherwise described herein. For example, it is not necessary in keeping with the principles of this disclosure for the wellbore **120** to include a generally vertical cased section. The well system **110** may

equally be employed in vertical and/or deviated wellbores, without departing from the scope of the present disclosure. Furthermore, it is not necessary for a single downhole tool **100** to be suspended from the tool string **118**.

**[0018]** In addition, it is not necessary for the downhole tool **100** to be lowered into the wellbore **120** using the derrick **112**. Rather, any other type of device suitable for lowering the downhole tool **100** into the wellbore **120** for placement at a desired location may be utilized without departing from the scope of the present disclosure such as, for example, mobile workover rigs, well servicing units, and the like. Although not depicted, the downhole tool **100** may alternatively be hydraulically pumped into the wellbore and, thus, not need the tool string **118** for delivery into the wellbore **120**.

**[0019]** Although not depicted, the structure of the downhole tool **100** may take on a variety of forms to provide fluid sealing between two wellbore sections. The downhole tool **100**, regardless of its specific structure as a specific type of wellbore zonal isolation device, comprises a body and a sealing element. Both the body and the sealing element may each be composed of the same material. Generally, however, the body provides structural rigidity and other mechanical features to the downhole tool **100** and the sealing element is a resilient (*i.e.*, elastic) material capable of providing a fluid seal between two sections of the wellbore **120**.

**[0020]** Referring now to **FIG. 2**, with continued reference to **FIG. 1**, one specific type of downhole tool described herein is a frac plug wellbore zonal isolation device for use during a well stimulation/fracturing operation. **FIG. 2** illustrates a cross-sectional view of an exemplary frac plug **200** being lowered into a wellbore **120** on a tool string **118**. As previously mentioned, the frac plug **200** generally comprises a body **210** and a sealing element **285**. The sealing element **285**, as depicted, comprises an upper sealing element **232**, a center sealing element **234**, and a lower sealing element **236**. It will be appreciated that although the sealing element **285** is shown as having three portions (*i.e.*, the upper sealing element **232**, the center sealing element **234**, and the lower sealing element **236**), any other number of portions, or a single portion, may also be employed without departing from the scope of the present disclosure.

**[0021]** As depicted, the sealing element **285** is extending around the body **210**; however, it may be of any other configuration suitable for allowing the sealing element **285** to form a fluid seal in the wellbore **120**,

without departing from the scope of the present disclosure. For example, in some embodiments, the body may comprise two sections joined together by the sealing element, such that the two sections of the body compress to permit the sealing element to make a fluid seal in the wellbore **120**. Other such configurations are also suitable for use in the embodiments described herein. Moreover, although the sealing element **285** is depicted as located in a center section of the body **210**, it will be appreciated that it may be located at any location along the length of the body **210**, without departing from the scope of the present disclosure.

**[0022]** The body **210** of the frac plug **200** comprises an axial flowbore **205** extending therethrough. A cage **220** is formed at the upper end of the body **210** for retaining a ball **225** that acts as a one-way check valve. In particular, the ball **225** seals off the flowbore **205** to prevent flow downwardly therethrough, but permits flow upwardly through the flowbore **205**. One or more slips **240** are mounted around the body **210** below the sealing element **285**. The slips **240** are guided by a mechanical slip body **245**. A tapered shoe **250** is provided at the lower end of the body **210** for guiding and protecting the frac plug **200** as it is lowered into the wellbore **120**. An optional enclosure **275** for storing a chemical solution may also be mounted on the body **210** or may be formed integrally therein. In one embodiment, the enclosure **275** is formed of a frangible material.

**[0023]** One or both of the body **210** and the sealing element **285** may be composed of a degradable material. Specifically, the sealing element **285** may be at least partially composed of an aqueous-degradable elastomer that degrades, at least in part, in the presence of an aqueous fluid, such as preexisting aqueous fluids or introduced aqueous fluids in a wellbore environment. That is, the aqueous-degradable elastomer forming at least a portion of the sealing element **285** may wholly degrade or partially degrade; however, the amount of degradation is capable of causing the sealing element **285** to no longer maintain a fluid seal in the wellbore capable of maintaining differential pressure. The aqueous fluid that may degrade the aqueous-degradable elastomer may include, but is not limited to, fresh water, saltwater (*e.g.*, water containing one or more salts dissolved therein), brine (*e.g.*, saturated salt water), seawater, or combinations thereof.

**[0024]** The aqueous-degradable elastomer forming at least a portion of the aqueous-degradable sealing element **285** may degrade by a number of mechanisms. For example, the aqueous-degradable sealing element **285** may degrade by swelling, dissolving, undergoing a chemical change, undergoing thermal degradation in combination with any of the foregoing, and any combination thereof. Degradation by swell involves the absorption by the aqueous-degradable elastomer of the aqueous fluid in the wellbore environment such that the mechanical properties of the elastomer degrade. That is, the aqueous-degradable elastomer continues to absorb the aqueous fluid until its mechanical properties are no longer capable of maintaining the integrity of the aqueous-degradable elastomer and it at least partially falls apart. In some embodiments, an aqueous-degradable elastomer may be designed to only partially degrade by swelling in order to ensure that the mechanical properties of the sealing element **285** formed from the aqueous-degradable elastomer is sufficiently capable of lasting for the duration of the specific operation in which it is utilized. Degradation by dissolving involves use of an aqueous-degradable elastomer that is soluble or otherwise susceptible to aqueous fluid, such that the aqueous fluid is not necessarily incorporated into the elastomer (as is the case with degradation by swelling), but becomes soluble upon contact with the aqueous fluid. Degradation by undergoing a chemical change may involve breaking the bonds of the backbone of the aqueous-degradable elastomer (*e.g.*, polymer backbone) or causing the bonds of the aqueous-degradable elastomer to crosslink, such that the aqueous-degradable elastomer becomes brittle and breaks into small pieces upon contact with even small forces expected in the wellbore environment. Electrochemical processes include galvanic corrosion, electrochemical corrosion, stress corrosion cracking, crevice corrosion, and pitting. Thermal degradation of the aqueous-degradable elastomer forming at least a portion of the aqueous-degradable sealing element **285** involves a chemical decomposition due to heat, such as the heat present in a wellbore environment. Thermal degradation of some aqueous-degradable elastomers described herein may occur at wellbore environment temperatures of greater than about 93°C (or about 200°F). Thermal degradation may work in concert with one or more of the other degradation methods that occurs when the aqueous-degradable sealing element **285** encounters an aqueous fluid.

**[0025]** The degradation rate of the aqueous-degradable elastomer forming the sealing element **285** may be accelerated, rapid, or normal, as defined herein. Accelerated degradation may be in the range of from a lower limit of about 30 minutes, 1 hour, 2 hours, 3 hours, 4 hours, 5 hours, and 6 hours to an upper limit of about 12 hours, 11 hours, 10 hours, 9 hours, 8 hours, 7 hours, and 6 hours, encompassing any value or subset therebetween. Rapid degradation may be in the range of from a lower limit of about 12 hours, 1 day, 2 days, 3 days, 4 days, and 5 days to an upper limit of about 10 days, 9 days, 8 days, 7 days, 6 days, and 5 days, encompassing any value or subset therebetween. Normal degradation may be in the range of from a lower limit of about 12 days, 13 days, 14 days, 15 days, 16 days, 17 days, 18 days, 19 days, 20 days, 21 days, 22 days, 23 days, 24 days, 25 days, and 26 days to an upper limit of about 40 days, 39 days, 38 days, 37 days, 36 days, 35 days, 34 days, 33 days, 32 days, 31 days, 30 days, 29 days, 28 days, 27 days, and 26 days, encompassing any value or subset therebetween. Accordingly, the degradation may be between about 30 minutes to about 40 days, depending on a number of factors including, but not limited to, the type of aqueous-degradable elastomer selected, the conditions of the wellbore environment, and the like.

**[0026]** The aqueous-degradable elastomer forming at least a portion of the aqueous-degradable sealing element **285** may be a material that is at least partially aqueous-degradable including, but not limited to, a polyurethane rubber; a polyester-based polyurethane rubber; a blend of chlorobutadiene rubber, reactive clay, and crosslinked sodium polyacrylate; a cellulose-based rubber (*e.g.*, carboxy methyl cellulose); an acrylate-based polymer; a polyethylene glycol-based hydrogel; a silicone-based hydrogel; a polyacrylamide-based hydrogel; a polymacon-based hydrogel; a hyaluronic acid rubber; a polyhydroxybutyrate rubber; a polyester elastomer; a polyester amide elastomer; a polyamide elastomer; copolymers thereof; terpolymers thereof; and any combination thereof. Examples of suitable copolymers and terpolymers may include, but are not limited to, a cellulose-based rubber and an acrylate rubber copolymer; a cellulose-based rubber, an acrylate rubber, and an acrylonitrile butadiene rubber terpolymer; an acrylate rubber and an acrylonitrile butadiene rubber copolymer; a cellulose-based rubber and an acrylonitrile butadiene rubber copolymer; and any combination thereof.

**[0027]** In some embodiments, the aqueous-degradable elastomer forming the sealing element **285** may have a thermoplastic polymer embedded therein. The thermoplastic polymer may modify the strength, resiliency, or modulus of the sealing element **285** and may also control the degradation rate of the sealing element **285**. Suitable thermoplastic polymers may include, but are not limited to, polypropylene, an aliphatic polyester (e.g., polyglycolic acid, polylactic acid, polycaprolactone, polyhydroxyalkanoate, polyhydroxyalkanoate, polyhydroxybutyrate, polyethylene adipate, polybutylene succinate, poly(lactic-co-glycolic) acid, poly(3-hydroxybutyrate-co-3-hydroxyvalerate), and any combination thereof. The amount of thermoplastic polymer that may be embedded in the aqueous-degradable elastomer forming the sealing element **285** may be any amount that confers a desirable elasticity without affecting the desired amount of degradation. In some embodiments, the thermoplastic polymer may be included in an amount in the range of a lower limit of about 1%, 5%, 10%, 15%, 20%, 25%, 30%, 35%, 40%, and 45% to an upper limit of about 91%, 85%, 80%, 75%, 70%, 65%, 60%, 55%, 50%, and 45% by weight of the aqueous-degradable elastomer, encompassing any value or subset therebetween.

**[0028]** The aqueous-degradable elastomer forming the sealing element **285** may in some cases further comprise an additive that may further influence the strength or resiliency of the sealing element **285** and, in some cases, affect the degradability or degradation rate of the sealing element **285**. Suitable additives may include, but are not limited to, an organophilic clay, silica flour, a metal oxide, and any combination thereof. In some embodiments, the additive may be included in an amount in the range of a lower limit of about 1%, 5%, 10%, 15%, 20%, 25%, 30%, 35%, 40%, and 45% to an upper limit of about 91%, 85%, 80%, 75%, 70%, 65%, 60%, 55%, 50%, and 45% by weight of the aqueous-degradable elastomer, encompassing any value or subset therebetween.

**[0029]** In some embodiments, the aqueous-degradable sealing element **285** may be at least partially encapsulated in a second material (e.g., a "sheath") formed from an encapsulating material capable of protecting or prolonging degradation of the sealing element **285** in a wellbore environment comprising an aqueous fluid. The sheath may also serve to protect the sealing element **285** from abrasion within the wellbore **120**. The structure of the

sheath may be permeable, frangible, or of a material that is at least partially removable at a desired rate within the wellbore environment. Whatever the structure, the sheath is designed such that it does not interfere with the ability of the sealing element **285** to form a fluid seal in the wellbore **120**. The encapsulating material forming the sheath may be any material capable of use in a downhole environment and, depending on the structure of the sheath may, or may not, be elastic such that it expands with the sealing element **285**. For example, a frangible sheath may break as the sealing element **285** expands to form a fluid seal, whereas a permeable sheath may remain in place on the sealing element **285** as it forms the fluid seal. As used herein, the term "permeable" refers to a structure that permits fluids (including liquids and gases) therethrough and is not limited to any particular configuration.

**[0030]** The encapsulating material forming the sheath may be of any material that the sealing element **285** itself may be made of, as described above, including aqueous-degradable materials having thermoplastic polymers and/or additives embedded therein. For example, the sheath may be made of an aqueous-degradable material that degrades faster than the aqueous-degradable material forming the sealing element **285**. Other suitable encapsulating materials may include, but are not limited to, a wax, a drying oil, a polyurethane, a crosslinked partially hydrolyzed polyacrylic, a silicate material, a glass material, an inorganic durable material, a polymer, a polylactic acid, a polyvinyl alcohol, a polyvinylidene chloride, and any combination thereof.

**[0031]** In some embodiments, the body **210**, or a portion thereof, may also be composed of a degradable material. Unlike the sealing element **285**, the body **210** is sufficiently rigid to provide structural integrity to the downhole tool, or frac plug **200**. The body **210** may degrade in the wellbore environment such as when exposed to an aqueous fluid, an elevated wellbore temperature, and/or a hydrocarbon fluid. The aqueous fluid may be any aqueous fluid present in the wellbore environment including, but not limited to, those listed above with reference to the sealing element **285**: fresh water, saltwater, brine, seawater, or combinations thereof. The body **210** may thermally degrade in a wellbore environment having temperatures greater than about 93°C (or about 200°F). The body **210** may also degrade upon contact with a hydrocarbon fluid in the wellbore environment. In such cases, the hydrocarbon fluid may include, but is not limited to, alkanes, olefins, aromatic

organic compounds, cyclic alkanes, paraffins, diesel fluids, mineral oils, desulfurized hydrogenated kerosenes, and any combination thereof. Suitable materials for forming the body **210** may include, but are not limited to, a polysaccharide, chitin, chitosan, a protein, an aliphatic polyester, poly( $\epsilon$ -caprolactone), a poly(hydroxybutyrate), poly(ethyleneoxide), poly(phenyllactide), a poly(amino acid), a poly(orthoester), polyphosphazene, a polylactide, a polyglycolide, a poly(anhydride) (e.g., poly(adipic anhydride), poly(suberic anhydride), poly(sebacic anhydride), poly(dodecanedioic anhydride), poly(maleic anhydride), and poly(benzoic anhydride), and the like), a polyepichlorohydrin, a copolymer of ethylene oxide/polyepichlorohydrin, a terpolymers of epichlorohydrin/ethylene oxide/allyl glycidyl ether, and any combination thereof. Suitable materials for forming the body **210** may also include, but are not limited to, metals or metal alloys that include magnesium, aluminum, iron, nickel, copper, gallium, zinc, zirconium, and the like, and any combination thereof. Combinations of the foregoing polymers and metals/metal alloys may be used in forming the body **210**.

**[0032]** In some embodiments, the body **210** may release an accelerant during degradation that accelerates the degradation of the sealing element **285**. In other embodiments, the sealing element **285** may release an accelerant that accelerates the degradation of the body **210**. In some cases, the accelerant is a natural component that is released upon degradation of either the body **210** or the sealing element **285**, such as an acid (e.g., release of an acid upon degradation of the body **210** formed from a polylactide). Similarly, the body **210** may release a base that would aid in degrading the sealing element **285**, such as, for example, if the body **210** were composed of a galvanically reacting material. In other cases, the accelerant may be embedded in the material forming either or both of the body **210** and the sealing element **285**. The accelerant may be in any form, including a solid or a liquid.

**[0033]** Suitable accelerants may include, but are not limited to, a chemical, a crosslinker, sulfur, a sulfur releasing agent, a peroxide, a peroxide releasing agent, a catalyst, an acid releasing agent, a base releasing agent, and any combination thereof. In some embodiments, the accelerant may cause the body **210** or the sealing element **285** to become brittle to aid in degradation. Specific accelerants may include, but are not limited to, a polylactide, a polyglycolide, an ester, a cyclic ester, a diester, an anhydride, a lactone, an



amide, an anhydride, an alkali metal alkoxide, a carbonate, a bicarbonate, an alcohol, an alkali metal hydroxide, ammonium hydroxide, sodium hydroxide, potassium hydroxide, an amine, an alkanol amine, an inorganic acid or precursor thereof (*e.g.*, hydrochloric acid, hydrofluoric acid, ammonium bifluoride, and the like), an organic acid or precursor thereof (*e.g.*, formic acid, acetic acid, lactic acid, glycolic acid, aminopolycarboxylic acid, polyaminopolycarboxylic acid, and the like), and any combination thereof.

**[0034]** The accelerant, when embedded in the body **210** or the sealing element **285**, may be present in the range of from a lower limit of about 0.01%, 0.01%, 0.1%, 1%, 2%, 3%, 4%, 5%, 6%, 7%, 8%, 9%, 10%, and 11% to an upper limit of about 25%, 24%, 23%, 22%, 21%, 20%, 19%, 18%, 17%, 16%, 15%, 14%, 13%, 12%, and 11% by weight of the material forming the body **210** or the sealing element **285**.

**[0035]** Each of the individual components forming the body **210** and the sealing element **285** (*i.e.*, the primary material and any additional material embedded therein) is preferably present in the body **210** and the sealing element **285** uniformly (*i.e.*, distributed uniformly throughout). The choices and relative amounts of each component are adjusted for the particular downhole operation (*e.g.*, fracturing, workover, and the like) and the desired degradation rate (*i.e.*, accelerated, rapid, or normal) of the body **210** and/or sealing element **285**. Factors that may affect the selection and amount of components may include, for example, the temperature of the subterranean formation in which the downhole operation is being performed, the expected amount of aqueous and/or hydrocarbon fluid in the wellbore environment, the amount of elasticity required for the sealing element **285** (*e.g.*, based on wellbore diameter, for example), the duration of the downhole operation, and the like.

**[0036]** Referring again to **FIG. 2**, in operation the frac plug **200** may be used in a downhole fracturing operation to isolate a zone of the formation **115** below the frac plug **200**. Referring now to **FIG. 3**, with continued reference to **FIG. 2**, the frac plug **200** is shown disposed between producing zone A and producing zone B in formation **115**. In a conventional fracturing operation, before setting the frac plug **200** to isolate zone A from zone B, a plurality of perforations **300** are made by a perforating tool (not shown) through the casing **125** and cement **127** to extend into producing zone A. Then a well stimulation fluid is introduced into the wellbore **120**, such as by

lowering a tool (not shown) into the wellbore **120** for discharging the fluid at a relatively high pressure or by pumping the fluid directly from the derrick **112** (**FIG. 1**) into the wellbore **120**. The well stimulation fluid passes through the perforations **300** into producing zone A of the formation **115** for stimulating the recovery of fluids in the form of oil and gas containing hydrocarbons. These production fluids pass from zone A, through the perforations **300**, and up the wellbore **120** for recovery at the surface **105** (**FIG. 1**).

**[0037]** The frac plug **200** is then lowered by the tool string **118** (**FIG. 1**) to the desired depth within the wellbore **120**, and the sealing element **285** (**FIG. 2**) is set against the casing **125**, thereby isolating zone A as depicted in **FIG. 3**. Due to the design of the frac plug **200**, the flowbore **205** (**FIG. 2**) of the frac plug **200** allows fluid from isolated zone A to flow upwardly through the frac plug **200** while preventing flow downwardly into the isolated zone A. Accordingly, the production fluids from zone A continue to pass through the perforations **300**, into the wellbore **120**, and upwardly through the flowbore **205** of the frac plug **200**, before flowing into the wellbore **120** above the frac plug **200** for recovery at the surface **105**.

**[0038]** After the frac plug **200** is set into position, as shown in **FIG. 3**, a second set of perforations **310** may then be formed through the casing **125** and cement **127** adjacent intermediate producing zone B of the formation **115**. Zone B is then treated with well stimulation fluid, causing the recovered fluids from zone B to pass through the perforations **310** into the wellbore **120**. In this area of the wellbore **120** above the frac plug **200**, the recovered fluids from zone B will mix with the recovered fluids from zone A before flowing upwardly within the wellbore **120** for recovery at the surface **105**.

**[0039]** If additional fracturing operations will be performed, such as recovering hydrocarbons from zone C, additional frac plugs **200** may be installed within the wellbore **120** to isolate each zone of the formation **115**. Each frac plug **200** allows fluid to flow upwardly therethrough from the lowermost zone A to the uppermost zone C of the formation **115**, but pressurized fluid cannot flow downwardly through the frac plug **200**.

**[0040]** After the fluid recovery operations are complete, the frac plug **200** must be removed from the wellbore **120**. In this context, as stated above, at least a portion of the sealing element **285** and/or body **210** (**FIG. 2**) of the frac plug **200** may degrade by exposure to the wellbore environment. For

example, the sealing element **285** and/or the body **210** may degrade upon prolonged contact with aqueous fluids present naturally or introduced in the wellbore **120**. Other combinations of degradability are suitable, without departing from the scope of the present disclosure, as discussed above, for example.

**[0041]** Accordingly, in an embodiment, the frac plug **200** is designed to decompose over time while operating in a wellbore environment, thereby eliminating the need to mill or drill the frac plug **200** out of the wellbore **120**. Thus, by exposing the frac plug **200** to an aqueous fluid, at least some of its components will decompose, causing the frac plug **200** to lose structural and/or functional integrity and release from the casing **125**. The remaining components of the frac plug **200** will simply fall to the bottom of the wellbore **120**. In various alternate embodiments, degrading one or more components of a downhole tool **100** performs an actuation function, opens a passage, releases a retained member, or otherwise changes the operating mode of the downhole tool **100**. Also, as described above, the material or components embedded therein for forming the body **210** and sealing element **285** of the frac plug **200**, as well as the use of the optional sheath, may be selected to control the decomposition rate of the frac plug **200**.

**[0042]** Referring again to **FIG. 1**, removing the downhole tool **100** from its attachment in the wellbore **120** is more cost effective and less time consuming than removing conventional downhole tools, which require making one or more trips into the wellbore **120** with a mill or drill to gradually grind or cut the tool away. Instead, the downhole tools **100** described herein are removable by simply exposing the tools **100** to a naturally occurring or standard downhole environment (*e.g.*, fluids present in a standard downhole operation) over time. The foregoing descriptions of specific embodiments of the downhole tool **100**, and the systems and methods for removing the biodegradable tool **100** from the wellbore **120** have been presented for purposes of illustration and description and are not intended to be exhaustive or to limit this disclosure to the precise forms disclosed. Many other modifications and variations are possible. In particular, the type of downhole tool **100**, or the particular components that make up the downhole tool **100** (*e.g.*, the body and sealing element) may be varied. For example, instead of a frac plug **200** (**FIG. 2**), the downhole tool **100** may comprise a bridge plug, which is designed to seal the

wellbore **120** and isolate the zones above and below the bridge plug, allowing no fluid communication in either direction. Alternatively, the biodegradable downhole tool **100** could comprise a packer that includes a shiftable valve such that the packer may perform like a bridge plug to isolate two formation zones, or the shiftable valve may be opened to enable fluid communication therethrough. Similarly, the downhole tool **100** could comprise a wiper plug or a cement plug.

**[0043]** While various embodiments have been shown and described herein, modifications may be made by one skilled in the art without departing from the scope of the present disclosure. The embodiments described here are exemplary only, and are not intended to be limiting. Many variations, combinations, and modifications of the embodiments disclosed herein are possible and are within the scope of the disclosure. Accordingly, the scope of protection is not limited by the description set out above, but is defined by the claims which follow, that scope including all equivalents of the subject matter of the claims.

**[0044]** Embodiments disclosed herein include Embodiment A, Embodiment B, and Embodiment C.

**[0045]** **Embodiment A:** A downhole tool that includes a body, wherein at least a portion of the body is degradable when exposed to a wellbore environment; and at least one aqueous-degradable sealing element composed of an aqueous-degradable elastomer, wherein the aqueous-degradable sealing element degrades when exposed to an aqueous fluid in the wellbore environment.

**[0046]** Embodiment A may have one or more of the following additional elements in any combination: Element A1: wherein the aqueous-degradable elastomer is selected from the group consisting of polyurethane rubber; a polyester-based polyurethane rubber; a blend of chlorobutadiene rubber, reactive clay, and crosslinked sodium polyacrylate; a cellulose-based rubber (*e.g.*, carboxy methyl cellulose); an acrylate-based polymer; a polyethylene glycol-based hydrogel; a silicone-based hydrogel; a polyacrylamide-based hydrogel; a polymacon-based hydrogel; a hyaluronic acid rubber; a polyhydroxybutyrate rubber; a polyester elastomer; a polyester amide elastomer; a polyamide elastomer; copolymers thereof; terpolymers thereof; and any combination thereof; Element A2: wherein the aqueous-degradable elastomer further comprises a thermoplastic polymer embedded therein;

Element A3: wherein the aqueous-degradable elastomer further comprises an additive selected from the group consisting of an organophilic clay, silica flour, a metal oxide, and any combination thereof; Element A4: wherein the aqueous-degradable sealing element is at least partially encapsulated in an encapsulating material, and wherein the encapsulating material delays degradation of the aqueous-degradable sealing element; Element A5: wherein the portion of the body that is degradable releases an accelerant during degradation, and wherein the accelerant accelerates the degradation of the aqueous-degradable sealing element; and Element A6: wherein the aqueous-degradable sealing element releases an accelerant during degradation, and wherein the accelerant accelerates the degradation of the portion of the body that is degradable.

**[0047]** By way of non-limiting example, exemplary combinations applicable to Embodiment A include: Element A1 in combination with Element A2 and optionally one or both of Elements A5 and A6; Element A1 in combination with Element A3 and optionally one or both of Elements A5 and A6; Element A1 in combination with Element A4 and optionally one or both of Elements A5 and A6; Element A2 in combination with Element A3 and optionally one or both of Elements A5 and A6; Element A2 in combination with Element A4 and optionally one or both of Elements A5 and A6; Element A3 in combination with Element A4 and optionally one or both of Elements A5 and A6; and one or both of Elements A5 and A6 in combination with one of Elements A1-A4.

**[0048] Embodiment B:** A method that includes installing a downhole tool in a wellbore, wherein the downhole tool comprises a body and at least one aqueous-degradable sealing element composed of an aqueous-degradable elastomer, and wherein at least a portion of the body is degradable when exposed to a wellbore environment and the aqueous-degradable sealing element degrades when exposed to an aqueous fluid in the wellbore environment; fluidly sealing two sections of the wellbore with the aqueous-degradable sealing element of the downhole tool, the aqueous-degradable sealing element capable of holding a differential pressure; performing a downhole operation; and degrading at least a portion of the aqueous-degradable sealing element such that the aqueous-degradable sealing element no longer is capable of holding the differential pressure.

**[0049]** Embodiment B may have one or more of the following additional elements in any combination: Element B1: the method further

including degrading at least a portion of the portion of the body that is degradable; Element B2: wherein the aqueous-degradable elastomer is selected from the group consisting of polyurethane rubber; a polyester-based polyurethane rubber; a blend of chlorobutadiene rubber, reactive clay, and crosslinked sodium polyacrylate; a cellulose-based rubber (*e.g.*, carboxy methyl cellulose); an acrylate-based polymer; a polyethylene glycol-based hydrogel; a silicone-based hydrogel; a polyacrylamide-based hydrogel; a polymacon-based hydrogel; a hyaluronic acid rubber; a polyhydroxybutyrate rubber; a polyester elastomer; a polyester amide elastomer; a polyamide elastomer; copolymers thereof; terpolymers thereof; and any combination thereof; Element B3: wherein the aqueous-degradable elastomer further comprises a thermoplastic polymer embedded therein; Element B4: wherein the aqueous-degradable elastomer further comprises an additive selected from the group consisting of an organophilic clay, silica flour, a metal oxide, and any combination thereof; Element B5: wherein the aqueous-degradable sealing element is at least partially encapsulated in an encapsulating material, and wherein the encapsulating material delays degradation of the aqueous-degradable sealing element; Element B6: wherein the portion of the body that is degradable releases an accelerant during degradation, and wherein the accelerant accelerates the degradation of the aqueous-degradable sealing element; and Element B7: wherein the aqueous-degradable sealing element releases an accelerant during degradation, and wherein the accelerant accelerates the degradation of the portion of the body that is degradable.

**[0050]** By way of non-limiting example, exemplary combinations applicable to Embodiment B include: Element B2 in combination with Element B3 and optionally one or both of Elements B6 and B7; Element B2 in combination with Element B4 and optionally one or both of Elements B6 and B7; Element B2 in combination with Element B5 and optionally one or both of Elements B6 and B7; Element B3 in combination with Element B4 and optionally one or both of Elements B6 and B7; Element B3 in combination with Element B5 and optionally one or both of Elements B6 and B7; Element B4 in combination with Element B5 and optionally one or both of Elements B6 and B7; one or both of Elements B6 and B7 in combination with one of Elements B2-B4; and Element B1 in combination with any of the foregoing.

**[0051] Embodiment C:** A system that includes a wellbore; and a downhole tool capable of being disposed in the wellbore to fluidly seal two sections thereof, the downhole tool comprising a body and at least one aqueous-degradable sealing element composed of an aqueous-degradable elastomer and the aqueous-degradable sealing element is capable of holding a differential pressure, wherein at least a portion of the body is degradable when exposed to the wellbore environment and the aqueous-degradable sealing element degrades in the wellbore environment.

**[0052]** Embodiment C may have one or more of the following additional elements in any combination: Element C1: wherein the aqueous-degradable elastomer is selected from the group consisting of polyurethane rubber; a polyester-based polyurethane rubber; a blend of chlorobutadiene rubber, reactive clay, and crosslinked sodium polyacrylate; a cellulose-based rubber (*e.g.*, carboxy methyl cellulose); an acrylate-based polymer; a polyethylene glycol-based hydrogel; a silicone-based hydrogel; a polyacrylamide-based hydrogel; a polymacon-based hydrogel; a hyaluronic acid rubber; a polyhydroxybutyrate rubber; a polyester elastomer; a polyester amide elastomer; a polyamide elastomer; copolymers thereof; terpolymers thereof; and any combination thereof; Element C2: wherein the aqueous-degradable elastomer further comprises a thermoplastic polymer embedded therein; Element C3: wherein the aqueous-degradable elastomer further comprises an additive selected from the group consisting of an organophilic clay, silica flour, a metal oxide, and any combination thereof; Element C4: wherein the aqueous-degradable sealing element is at least partially encapsulated in an encapsulating material, and wherein the encapsulating material delays degradation of the aqueous-degradable sealing element; Element C5: wherein the portion of the body that is degradable releases an accelerant during degradation, and wherein the accelerant accelerates the degradation of the aqueous-degradable sealing element; and Element C6: wherein the aqueous-degradable sealing element releases an accelerant during degradation, and wherein the accelerant accelerates the degradation of the portion of the body that is degradable.

**[0053]** By way of non-limiting example, exemplary combinations applicable to Embodiment C include: Element C1 in combination with Element C2 and optionally one or both of Elements C5 and C6; Element C1 in combination with Element C3 and optionally one or both of Elements C5 and C6; Element C1

in combination with Element C4 and optionally one or both of Elements C5 and C6; Element C2 in combination with Element C3 and optionally one or both of Elements C5 and C6; Element C2 in combination with Element C4 and optionally one or both of Elements C5 and C6; Element C3 in combination with Element C4 and optionally one or both of Elements C5 and C6; and one or both of Elements C5 and C6 in combination with one of Elements C1-C4.

**[0054]** Therefore, the disclosed systems and methods are well adapted to attain the ends and advantages mentioned as well as those that are inherent therein. The particular embodiments disclosed above are illustrative only, as the teachings of the present disclosure may be modified and practiced in different but equivalent manners apparent to those skilled in the art having the benefit of the teachings herein. Furthermore, no limitations are intended to the details of construction or design herein shown, other than as described in the claims below. It is therefore evident that the particular illustrative embodiments disclosed above may be altered, combined, or modified and all such variations are considered within the scope and spirit of the present disclosure. The systems and methods illustratively disclosed herein may suitably be practiced in the absence of any element that is not specifically disclosed herein and/or any optional element disclosed herein. While compositions and methods are described in terms of "comprising," "containing," or "including" various components or steps, the compositions and methods can also "consist essentially of" or "consist of" the various components and steps. All numbers and ranges disclosed above may vary by some amount. Whenever a numerical range with a lower limit and an upper limit is disclosed, any number and any included range falling within the range is specifically disclosed. In particular, every range of values (of the form, "from about a to about b," or, equivalently, "from approximately a to b," or, equivalently, "from approximately a-b") disclosed herein is to be understood to set forth every number and range encompassed within the broader range of values. Also, the terms in the claims have their plain, ordinary meaning unless otherwise explicitly and clearly defined by the patentee. Moreover, the indefinite articles "a" or "an," as used in the claims, are defined herein to mean one or more than one of the element that it introduces.



## CLAIMS

The invention claimed is:

1. A downhole tool comprising:
  - a body, wherein at least a portion of the body is degradable when exposed to a wellbore environment; and
  - at least one aqueous-degradable sealing element composed of an aqueous-degradable elastomer, wherein the aqueous-degradable sealing element degrades when exposed to an aqueous fluid in the wellbore environment.
2. The downhole tool of claim 1, wherein the aqueous-degradable elastomer is selected from the group consisting of polyurethane rubber; a polyester-based polyurethane rubber; a blend of chlorobutadiene rubber, reactive clay, and crosslinked sodium polyacrylate; a cellulose-based rubber (*e.g.*, carboxy methyl cellulose); an acrylate-based polymer; a polyethylene glycol-based hydrogel; a silicone-based hydrogel; a polyacrylamide-based hydrogel; a polymacon-based hydrogel; a hyaluronic acid rubber; a polyhydroxybutyrate rubber; a polyester elastomer; a polyester amide elastomer; a polyamide elastomer; copolymers thereof; terpolymers thereof; and any combination thereof.
3. The downhole tool of claim 1, wherein the aqueous-degradable elastomer further comprises a thermoplastic polymer embedded therein.
4. The downhole tool of claim 1, wherein the aqueous-degradable elastomer further comprises an additive selected from the group consisting of an organophilic clay, silica flour, a metal oxide, and any combination thereof.
5. The downhole tool of claim 1, wherein the aqueous-degradable sealing element is at least partially encapsulated in an encapsulating material, and wherein the encapsulating material delays degradation of the aqueous-degradable sealing element.

6. The downhole tool of claim 1, wherein the portion of the body that is degradable releases an accelerant during degradation, and wherein the accelerant accelerates the degradation of the aqueous-degradable sealing element.

7. The downhole tool of claim 1, wherein the aqueous-degradable sealing element releases an accelerant during degradation, and wherein the accelerant accelerates the degradation of the portion of the body that is degradable.

8. A method comprising:

installing a downhole tool in a wellbore, wherein the downhole tool comprises a body and at least one aqueous-degradable sealing element composed of an aqueous-degradable elastomer, and

wherein at least a portion of the body is degradable when exposed to a wellbore environment and the aqueous-degradable sealing element degrades when exposed to an aqueous fluid in the wellbore environment;

fluidly sealing two sections of the wellbore with the aqueous-degradable sealing element of the downhole tool, the aqueous-degradable sealing element capable of holding a differential pressure;

performing a downhole operation; and

degrading at least a portion of the aqueous-degradable sealing element such that the aqueous-degradable sealing element no longer is capable of holding the differential pressure.

9. The method of claim 8, further comprising degrading at least a portion of the portion of the body that is degradable.

10. The method of claim 8, wherein the aqueous-degradable elastomer is selected from the group consisting of polyurethane rubber; a polyester-based polyurethane rubber; a blend of chlorobutadiene rubber, reactive clay, and crosslinked sodium polyacrylate; a cellulose-based rubber (*e.g.*, carboxy methyl cellulose); an acrylate-based polymer; a polyethylene glycol-based hydrogel; a silicone-based hydrogel; a polyacrylamide-based hydrogel; a polylactone-based hydrogel; a hyaluronic acid rubber; a polyhydroxybutyrate rubber; a polyester

elastomer; a polyester amide elastomer; a polyamide elastomer; copolymers thereof; terpolymers thereof; and any combination thereof.

11. The method of claim 8, wherein the aqueous-degradable elastomer further comprises a thermoplastic polymer embedded therein.

12. The method of claim 8, wherein the aqueous-degradable elastomer further comprises an additive selected from the group consisting of an organophilic clay, silica flour, a metal oxide, and any combination thereof.

13. The method of claim 8, wherein the aqueous-degradable sealing element is at least partially encapsulated in an encapsulating material, and wherein the encapsulating material delays degradation of the aqueous-degradable sealing element.

14. The method of claim 8, wherein the portion of the body that is degradable releases an accelerant during degradation, and wherein the accelerant accelerates the degradation of the aqueous-degradable sealing element.

15. The method of claim 8, wherein the aqueous-degradable sealing element releases an accelerant during degradation, and wherein the accelerant accelerates the degradation of the portion of the body that is degradable.

16. A system comprising:

a wellbore; and

a downhole tool capable of being disposed in the wellbore to fluidly seal two sections thereof, the downhole tool comprising a body and at least one aqueous-degradable sealing element composed of an aqueous-degradable elastomer and the aqueous-degradable sealing element is capable of holding a differential pressure,

wherein at least a portion of the body is degradable when exposed to the wellbore environment and the aqueous-degradable sealing element degrades in the wellbore environment.

17. The system of claim 16, wherein the aqueous-degradable elastomer is selected from the group consisting of polyurethane rubber; a polyester-based polyurethane rubber; a blend of chlorobutadiene rubber, reactive clay, and crosslinked sodium polyacrylate; a cellulose-based rubber (e.g., carboxy methyl cellulose); an acrylate-based polymer; a polyethylene glycol-based hydrogel; a silicone-based hydrogel; a polyacrylamide-based hydrogel; a polymacon-based hydrogel; a hyaluronic acid rubber; a polyhydroxybutyrate rubber; a polyester elastomer; a polyester amide elastomer; a polyamide elastomer; copolymers thereof; terpolymers thereof; and any combination thereof.

18. The system of claim 16, wherein the aqueous-degradable elastomer further comprises a thermoplastic polymer embedded therein.

19. The system of claim 16, wherein the aqueous-degradable elastomer further comprises an additive selected from the group consisting of an organophilic clay, silica flour, a metal oxide, and any combination thereof.

20. The system of claim 16, wherein the aqueous-degradable sealing element is at least partially encapsulated in an encapsulating material, and wherein the encapsulating material delays degradation of the aqueous-degradable sealing element.

21. The system of claim 16, wherein the portion of the body that is degradable releases an accelerant during degradation, and wherein the accelerant accelerates the degradation of the aqueous-degradable sealing element.

22. The system of claim 16, wherein the aqueous-degradable sealing element releases an accelerant during degradation, and wherein the accelerant accelerates the degradation of the portion of the body that is degradable.

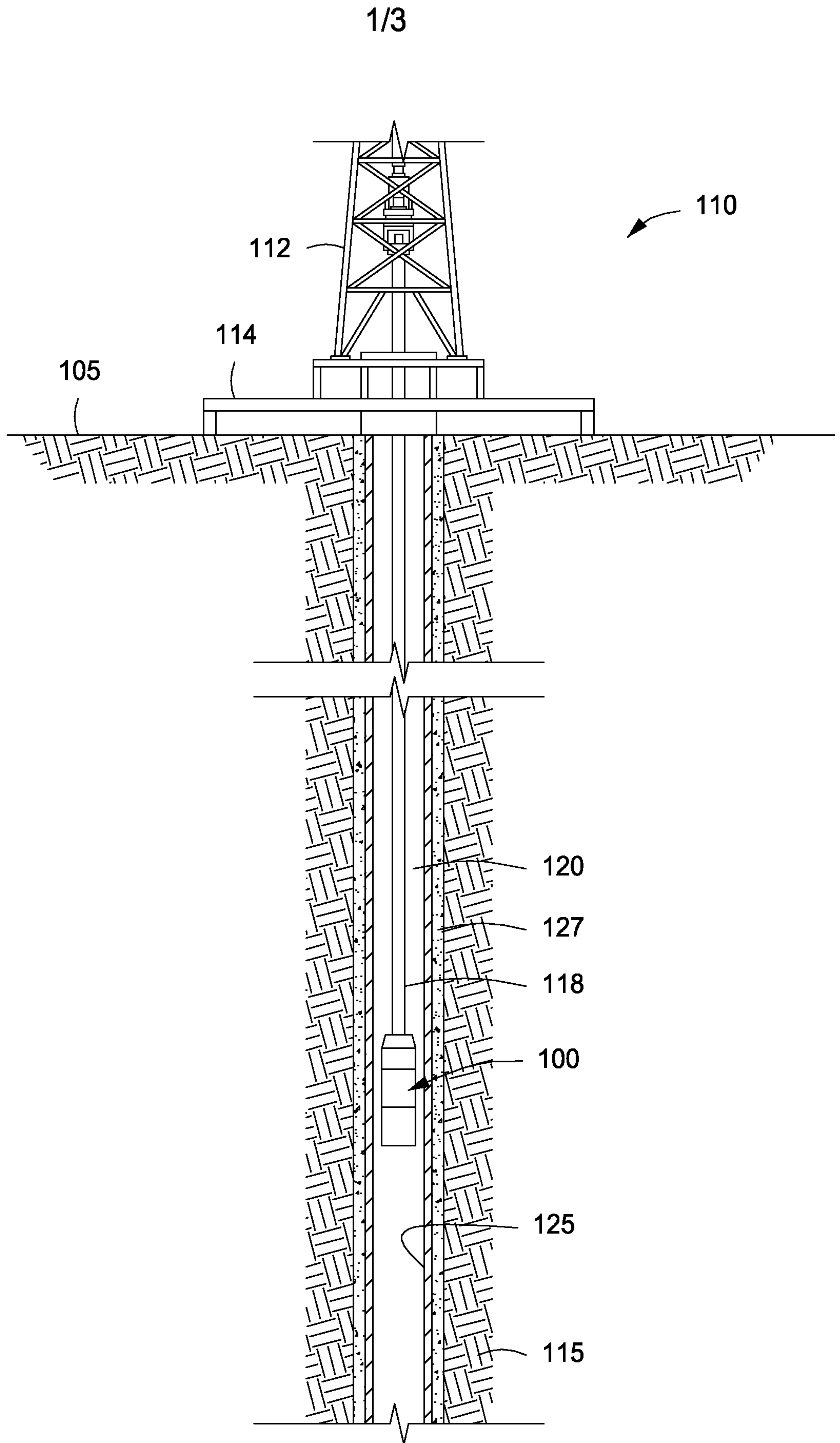

FIG. 1

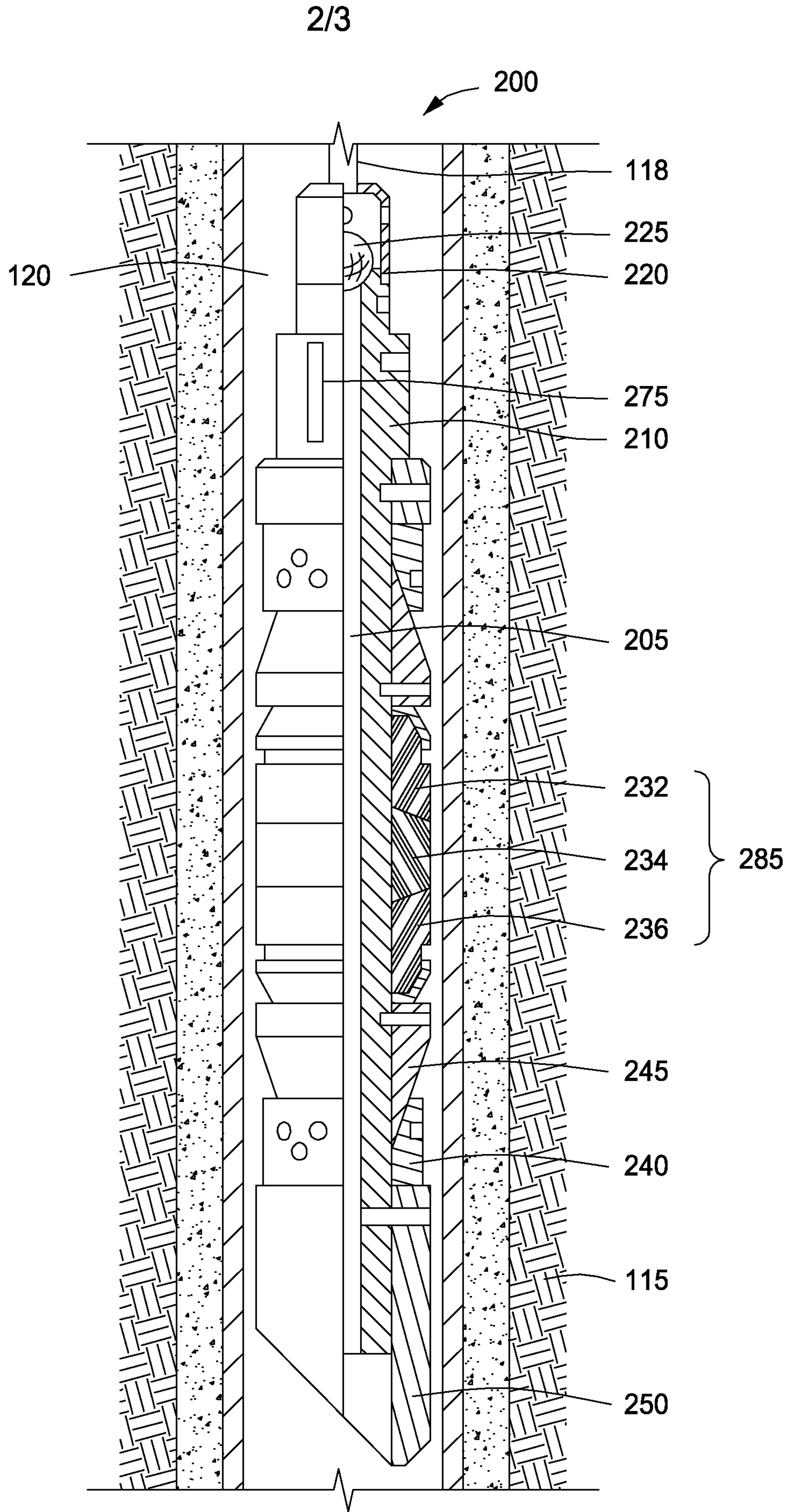
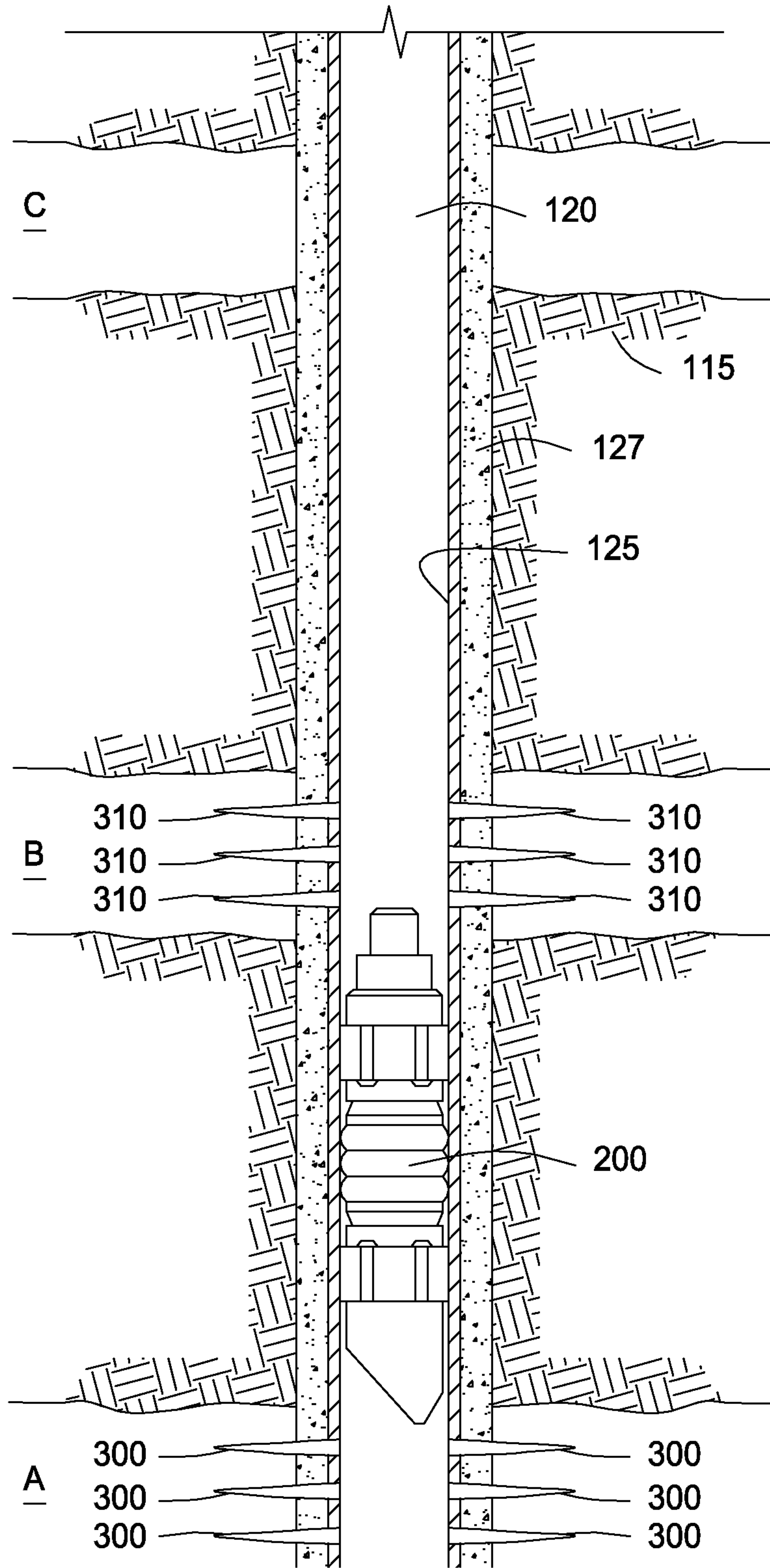

FIG. 2

3/3



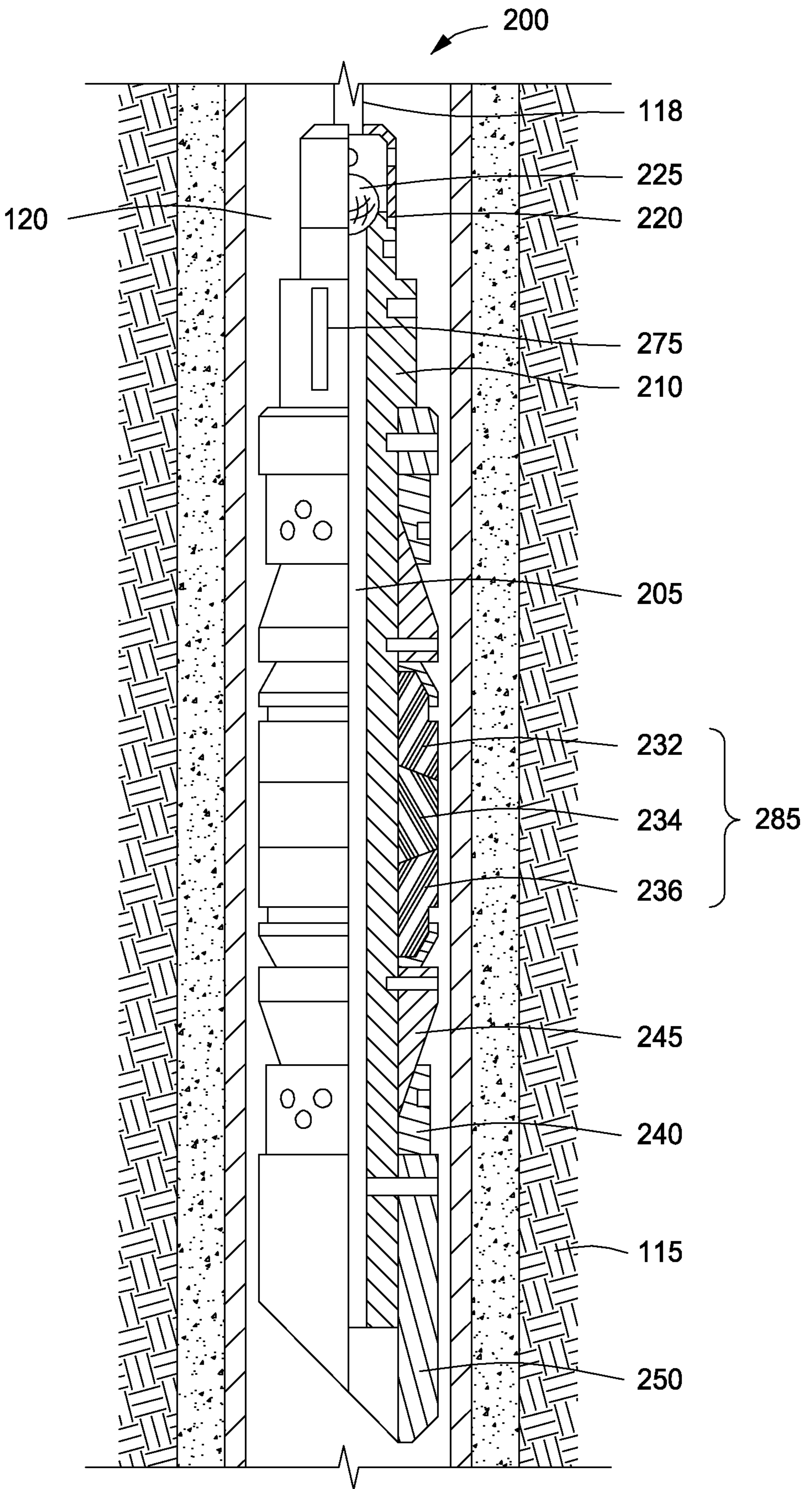

FIG. 2