

(19) World Intellectual Property Organization  
International Bureau



(43) International Publication Date  
5 January 2012 (05.01.2012)

(10) International Publication Number  
**WO 2012/001217 A1**

- (51) **International Patent Classification:**  
B62B 3/02 (2006.01) B65D 19/42 (2006.01)  
B62B 5/00 (2006.01)
- (21) **International Application Number:**  
PCT/FI2010/050574
- (22) **International Filing Date:**  
2 July 2010 (02.07.2010)
- (25) **Filing Language:** English
- (26) **Publication Language:** English
- (71) **Applicant (for all designated States except US):** K. HARTWALL OY AB [FI/FI]; Kay Hartwalls väg 2, FI-01 150 Soderkulla (FI).
- (72) **Inventor; and**
- (75) **Inventor/Applicant (for US only):** TIIKAINEN, Markku [FI/FI]; c/o K. Hartwall Oy Ab, Kay Hartwalls väg 2, FI-01 150 Soderkulla (FI).
- (74) **Agent:** SEPPO LAINE OY; Itamerenkatu 3 B, FI-00180 Helsinki (FI).

- (81) **Designated States (unless otherwise indicated, for every kind of national protection available):** AE, AG, AL, AM, AO, AT, AU, AZ, BA, BB, BG, BH, BR, BW, BY, BZ, CA, CH, CL, CN, CO, CR, CU, CZ, DE, DK, DM, DO, DZ, EC, EE, EG, ES, FI, GB, GD, GE, GH, GM, GT, HN, HR, HU, ID, IL, IN, IS, JP, KE, KG, KM, KN, KP, KR, KZ, LA, LC, LK, LR, LS, LT, LU, LY, MA, MD, ME, MG, MK, MN, MW, MX, MY, MZ, NA, NG, NI, NO, NZ, OM, PE, PG, PH, PL, PT, RO, RS, RU, SC, SD, SE, SG, SK, SL, SM, ST, SV, SY, TH, TJ, TM, TN, TR, TT, TZ, UA, UG, US, UZ, VC, VN, ZA, ZM, ZW.
- (84) **Designated States (unless otherwise indicated, for every kind of regional protection available):** ARIPO (BW, GH, GM, KE, LR, LS, MW, MZ, NA, SD, SL, SZ, TZ, UG, ZM, ZW), Eurasian (AM, AZ, BY, KG, KZ, MD, RU, TJ, TM), European (AL, AT, BE, BG, CH, CY, CZ, DE, DK, EE, ES, FI, FR, GB, GR, HR, HU, IE, IS, IT, LT, LU, LV, MC, MK, MT, NL, NO, PL, PT, RO, SE, SI, SK, SM, TR), OAPI (BF, BJ, CF, CG, CI, CM, GA, GN, GQ, GW, ML, MR, NE, SN, TD, TG).

[Continued on next page]

(54) **Title:** DOLLY AND FRAME ASSEMBLY FOR THE SAME

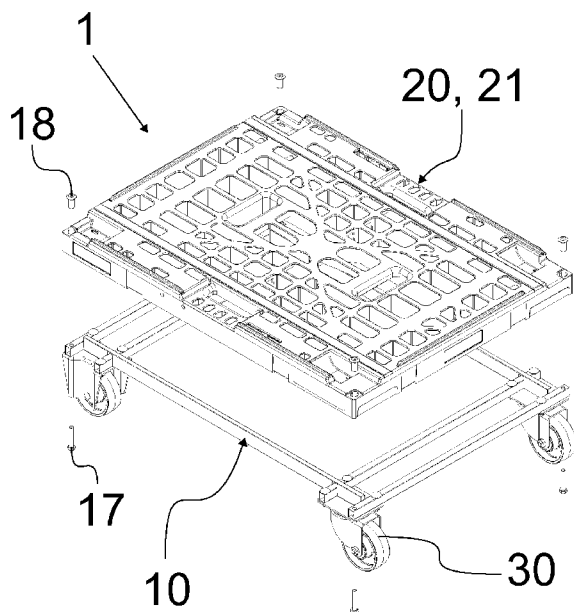

FIG. 1

(57) **Abstract:** The present invention provides a dolly(1) for transporting objects and a frame assembly for said dolly(1). The dolly(1) comprises an engagement member (20) made of formable material and having an engaging side (21) shaped for receiving 5 carriers and a back side (22) opposite to the engaging side (21), a load-bearing frame (10), to which a plurality of wheels (30) are mounted, and an abutment between the frame (10) and the engagement member (20) for fastening the engagement member (20) to the frame (10), whereby a single type of load-bearing 10 frame (10) is applicable to a variety of engagement members (20).

WO 2012/001217 A1

Published:

— with international search report (Art. 21(3))

## **Dolly and frame assembly for the same**

### *Field of the invention*

The present invention relates to transporting goods. In particular, the invention relates to dollies, on which parceled goods are transported and stored temporarily. To be precise,  
5 the invention relates to a dolly and a frame assembly according to the preamble portions of claims 1 and 12.

### *Background art*

There is known a vast variety of different devices used for transporting parceled goods. Typically pieces or stacks thereof are loaded onto a wheeled platform, on which they are  
10 conveyed to shop floor or storage. These wheeled platforms are called dollies. Generic dollies are typically designed to provide a simple wheeled platform that is not intended to receive a specific piece. On the contrary, the design principle is to provide a structure that can bear the weight of heavy objects, such as engines, transmissions, industrial pumps and similar objects that would otherwise be difficult to transport by carrying. According-  
15 ly, generic dollies traditionally feature a simple frame welded together from a plurality of steel beams and castors bearing-mounted to the bottom side of the frame assembly.

While generic dollies can withstand heavy loads, they are unfortunately rather cumbersome and do not provide proper support, especially lateral support, for the contents. To overcome this problem, customized dollies with appropriate object receiving shapes have  
20 been developed. Customized dollies typically comprise a platform, which is customized to receive and support a carrier of specific shape, and castors adapted to the bottom surface of the platform. Such customized dollies are made of plastic and are used for transporting parceled goods, e.g. beverage containers, such as single or multi-packed bottles. The plastic platforms are typically injection molded to provide a form-fitting landscape  
25 that is able to conform to the shape of the parceled goods or carriers thereof.

It is also known to provide a recess to the top surface of the dolly to receive the wheels of a superimposed second dolly, whereby a stack of empty dollies can be formed to save space.

However, known dollies are not always ideal for use in a typical dynamic environment, in which the conveyable objects can vary depending on the current transportation need and in which the dollies are subjected to wearing use. More specifically, current customized dollies are suitable for a very limited range of different objects and have been  
5 proven rather frail. One particular problem with traditional dollies is that the wheels attached to the platform experience rough handling by e.g. forklift forks, whereby the castor flange shears off the platform.

#### *Aim of the invention*

It is therefore an aim of the present invention to solve at least part of the problems related  
10 to prior art and to provide an improved dolly.

It is a particular aim to provide a dolly that is or can be easily customized to be suitable for a large range of different objects and that is resistant to rough handling and heavy loads.

#### *Summary*

15 The aim is achieved with a novel dolly for transportation of objects, such as single or multi-packed bottles. The dolly according to the invention comprises an engagement member, which is made of formable material and has an engaging side shaped for receiving carriers and a back side opposite to the engaging side. The dolly also comprises load-bearing frame, to which a plurality of wheels are bearing-mounted. There is an abutment  
20 between the frame and the engagement member, preferably between the frame and the back side of the engagement member, for fastening the engagement member to the frame. Accordingly, a single type of load-bearing frame is applicable a variety of engagement members shaped for a variety of carriers.

More specifically, the dolly according to the invention is characterized by what is stated  
25 in the characterizing portion of claim 1.

The present invention also provides a frame assembly for a dolly of claim 1. The frame assembly comprises a plurality of interconnectable beams, which are adapted to be connected to each other by cribbing joints.

According to one embodiment, the frame assembly comprises two mutually parallel longitudinal beams and at least two mutually parallel transverse beams, which connect the longitudinal beams by cribbing joints forming a rectangular frame, and wheels, which are fixed with screw joints to the joints between the beams of the frame so that the screw joints secure also the engagement member to the frame.

More specifically, the frame assembly according to the invention is characterized by what is stated in the characterizing portion of claim 12.

Considerable benefits are gained with aid of the present invention. Because the engagement member and the load-bearing frame are separate components of the dolly, it can be customized to cater for the variable need of transporting a range of different objects by simply changing the engagement member. Accordingly, the load-bearing frame can be a universal component that is applicable to a variety different objects that would otherwise require an entirely new dolly.

As the frame bears the weight of the load, the object receiving and supporting engagement member can be manufactured from a material that is easy to form and that can be made flexible and thus better suited for accommodating the objects. Moreover, the wheels are attached to the strong frame, whereby the wheels are more robustly fixed to the dolly thus improving its resistance to heavy use.

According to the other aspect to the invention, the frame itself can also be constructed from modular components, whereby the dolly can be easily repaired and manufactured with a minimal variety of components.

Further benefits gained with specific featured are described in greater detail hereafter upon description of different embodiments of the invention.

#### *Brief description of drawings*

In the following, certain embodiments of the present invention are described in detail with reference to the accompanying drawings, in which:

Fig. 1 presents an exploded view of a dolly according to first embodiment of the invention,

Fig. 2 presents an assembled view of the dolly of Fig. 1,

Fig. 3 presents the engagement member of the dolly of Fig. 1,

Fig. 4 presents a disassembled frame of the dolly of Fig. 1,

Fig. 5 presents an assembled frame of Fig. 4,

5 Fig. 6 presents an exploded view of the frame of Fig. 4 with wheels and attachment means,

Fig. 7 presents an assembled frame of Fig. 6,

Fig. 8 presents a detailed cross-section view of a curved wheel reception well of the engagement member of Fig. 3,

10 Fig. 9 presents a detailed cross-section view of a chamfered wheel reception well of the engagement member of Fig. 3,

Fig. 10 presents an exploded view of a dolly according to second embodiment of the invention,

Fig. 11 presents a partly assembled view of the dolly of Fig. 10,

15 Fig. 12 presents an assembled view of the dolly of Fig. 10, and

Fig. 13 presents a disassembled view of a snap-fit joint between the adaptor and the engagement member of Figs. 10 to 12.

#### *Detailed description of preferred embodiments*

As illustrated in Fig. 1, the dolly 1 according to the first aspect of the invention comprises a rectangular load-bearing frame 10. To the corners of the frame 10 are provided  
20 wheels 30, which are preferably standardized wheels found in industrial castor pallets etc. The frame 10 is designed to withstand rough handling and wearing use, whereby the frame 10 is made of material able to provide a robust structure. Such a material would be steel, particularly high-tensile steel, aluminum or even carbon fiber. Obviously the material is a trade-off between strength and cost, whereby steel is a preferred material.  
25

Whatever the frame material may be, formability of the material has a minimal importance since the frame 10 is not designed to receive the movable object but designed to bear the load thereof. The frame 10 must therefore be rigid enough to carry the weight of the load packed on the dolly 1. In practice, the wheels 30 usually experience a great share of abuse caused by rough handling, wherein it is advantageous to fix them into the rugged steel frame 10 so that the handling-related strain is not delivered to any fragile plastic parts. Details of the frame 10 are discussed hereafter.

The dolly 1 further comprises an engagement member 20, which can be fixed - preferably detachably - to the frame 10. The engagement member 20 is made of easily pourable and formable polymer material, such as polypropylene (PP), polyamide (PA), acrylonitrile butadiene styrene (ABS), high-density polyethylene (HDPE) or similar, whereby the engagement member 20 can be designed to receive a specific shape or shapes of carriers for performing as an customized interface between dolly 1 and the goods. The top surface 21 of the engagement member 20 can also be equipped with grip strips 25 adapted to provide high friction between the engagement member 20 and the object loaded thereon.

The dolly 1 comprises an abutment between the frame 10 and the engagement member 20. According to the embodiment of Figs. 1 and 2, the engagement member 20 is connected to the frame 10 with a screw joint 17, 18, which is formed when the dolly is assembled (Fig. 2). Other joints are also possible and they are discussed hereafter. Accordingly, the abutment can be established in many different ways while form-fitting joints are preferred. However, in principle the frame 10 is preferably designed as a universal platform for accommodating a variety of engagement members 20 designed to receive a respective variety of different carriers or other objects to be transported.

As illustrated in Fig. 3, the engagement member 20 shares the rectangular shape with the load-bearing frame 10. The top surface, on which the goods are loaded, is herein referred to as the engaging side 21, which is preferably shaped to form a landscape for providing as much support to the cargo as possible. The side opposite to the engaging side 21 is referred to as the back side 22, which is shaped to engage with the frame 10, i.e. to form the abutment. For example, the back side 22 of the engagement member 20 is provided with grooves (not shown in detail) for receiving protruding edges of the longitudinal beams 12 of the frame 10 (Figs. 1 and 5). As part of the abutment, the engagement mem-

ber 20 also comprises holes provided into the corners to receive screws 17 and their counterparts 18 for fixing the engagement member 20 into the frame 10 (Fig. 1). The engagement member 20 is further preferably provided with as many drainage holes as possible for draining out accumulating water and impurities.

5 Referring now to Figs. 3, 8 and 9, the corners of the engaging side 21 of the engagement member 20 is equipped with recesses for receiving the wheels 30 of a superimposed dolly 1, whereby a plurality of dollies 1 can be stacked on top of each other. According to a preferred embodiment, the wheel reception wells 23 are adapted to receive the wheel 30 so that the well 23 and the wheel 30 share three contact points. Because the wheels 30  
10 have round outer surfaces, they tend to swing back and forth in an equally round well, when the dolly stack experiences lateral impacts. To overcome the pendulum effect, the wheel 30 is supported from three contact points spread along the circumference thereof, which can be done in a variety of ways.

According to one embodiment shown in Fig. 8, the engagement side 21 has a rounded  
15 wheel reception well 23b, which comprises a flat bottom portion forming the lowest contact point (middle dot) being surrounded by an essentially upright wall and an arch forming the lateral contact points (left and right dot). Such a rounded wheel reception well 23b is especially suitable for receiving a steerable wheel 30.

According to another embodiment shown in Fig. 9, the engagement surface 21 has a  
20 chamfered wheel reception well 23a, which comprises three flat portions, the middle one of which forms the lowest contact point, where as the surrounding tilted walls form lateral contact points. Such a chamfered wheel reception well 23a is especially suitable for receiving an aligned wheel 30.

Referring now to Figs. 4 to 7, the frame 10 of the dolly 1 is preferably made as a univer-  
25 sal chassis to cater for a specific size range of dollies that can be customized for different cargo by changing the engagement member 20. In other words, the frame 10 is an independent modular load-bearing component of the dolly 1, which in itself can be customized by easily formable polymer engagement members 20. Moreover, the components of the frame 10 are preferably also inter-mountable modular parts that have standardized



joint interfaces, whereby the parts can be manufactured with a minimal set of tools and are interchangeable.

As illustrated in Fig. 4, the frame 10 can be formed by using simple longitudinal and transverse beams 11, 12 joined together by cribbing joints 13, 14, 19 according to a preferable embodiment. More precisely the frame 10 comprises two mutually parallel longitudinal beams 12 and four parallel transverse beams 11. The beams 11, 12 are hollow profiles having e.g. a rectangular cross-section. The beams have preferably a closed profile of inexpensive and strong material such as cold formed steel. Other shapes and materials are also applicable. The longitudinal beams 12 have been provided with slits 19 and apertures 13 that are dimensioned to conform to the cross-section of the transversal beams 11. Accordingly, the transversal beams 11 are provided with cribbing cavities 14 for forming a joint with the apertures 13 of the longitudinal beams 12. The frame 10 is therefore assembled by forming cribbing joints, in which the slits 19 and apertures 13 of the longitudinal beams 12 are respectively connected with the cribbing cavities 14 of the transverse beams 11, wherein a rectangular frame 10 comprises two single-beam sides 12 and two double-beam sides 11 perpendicular to the single-beam sides 12 (Fig. 5).

The transverse beams 11 are provided with vertical through holes adapted on either side to the portion for accommodating the longitudinal beam 12. As illustrated in Figs. 6 and 7, wheels 30 are attached to the frame 10 by inserting screws 15 through said holes, which screws 15 are secured with nuts 16 provided on the other side of the wheel flange. The screw joints 15, 16 also secure the beams 11, 12 to each other, whereby the frame 10 can be assembled with very few attachment members. Because the frame 10 is assembled with detachable attachment means, it can be easily disassembled, whereby damaged parts, i.e. failed wheels 30 or bent beams, may be replaced.

As is also apparent from Figs. 4 to 7, the frame is assembled with only three screws 15 in each corner of the frame 10 while each corner is provided with four receptive holes. The one remaining hole is used for attaching other parts of the dolly 1 to the frame 10. Furthermore, the beams 11, 12 and cribbing joint shapes 13, 14, 19 are preferably dimensioned so that a small ridge or rail is formed on top of the longitudinal beam 12 for forming a form-fitting shape to engage with other parts 20 assembled on top of the frame 10.

Without departing from the scope of the invention, the frame 10 can be constructed with a deviating manner. For example, instead of cribbing joints 13, 14, 19 the beams 11, 12 may be connected by other connecting means, such as welding or screw joint. Alternatively the frame 10 can be cast. Overall, it is preferable to favor constructions that can be easily disassembled.

Furthermore, other frame assemblies deviant to that illustrated in Figs. 4 to 7 are also feasible. For example, according to one embodiment (not shown), the frame 10 comprises only one longitudinal beam 12 that is provided to the center of the frame 10. To each end of the central longitudinal beam 12 has been fixed at least one transverse beam 11 with cribbing joints as described above. Accordingly, the shape of the frame 10 resembles the letter H, wherein the wheels 30 are attached to the terminal ends of the vertical branches of the letter H, i.e. the transverse beams 11. Such a construction would be especially suitable for light applications, such as a dolly designed for transporting plants etc.

Naturally, it is within the competence of a skilled person to construct a further variety of frames 10 conforming to above described concept.

According to the second aspect of the invention, the dolly 1 comprises an adaptor 40, which connects the engagement member 20 to the frame 10 (Fig. 10). As illustrated in Fig. 11, the adaptor 40 is an interface that is fixed to the frame 10 by, e.g., a similar screw connection as illustrated in Fig. 1. The adaptor 40 shares its shape with that of the frame 10, e.g. rectangle, and is preferably injection molded of polypropylene (PP), polyamide (PA), acrylonitrile butadiene styrene (ABS), high-density polyethylene (HDPE) or similar. Accordingly the lower surface of the adaptor 40 is provided with shapes designed to intermesh with corresponding shapes of the frame 10, such as the small ridge or rail on top of the longitudinal beam 12. The ridge is also designed to form a form-fitting shape to engage with the back side 22 of engagement member 20 of the first aspect of the invention.

Referring back to the second aspect, the upper surface of the adaptor 40 is on the other hand adapted to form an easily established connection to the engagement member 20, more specifically its back side 22. Ideally, the adaptor 40 is fixed detachably to the frame 10 upon assembly thereof and an engagement member 20 suitable for the current trans-

portation object is snapped onto the adaptor 40 with a form-fitting joint (Fig. 12). Compared to the first aspect of the invention, the snap-fit connection between the frame 10 and engagement member 20 via adaptor 40 of the second aspect requires no tools and may be performed faster.

5 According to one embodiment illustrated in Figs. 10, 11 and 13, such a snap-fit joint is provided by equipping the back side 22 of the engaging member 20 with a circular joint sleeve 24 comprising a plurality of elastically bendable lugs arranged on the periphery. Accordingly the receiving adaptor 40 is provided with corresponding cylindrical recep-  
10 tacles 41. Naturally, the joint member 24 of the of the engagement member 20 and the receptacles 41 may have another cross-section shape, such as a rectangle, hexagonal etc. Thus carrier-specific engagement member 20 can be changeably snapped onto a modular and standardized dolly chassis assembly formed by the wheels 30, frame 10 and adaptor 40.

The engagement member 20 may be shaped so as to provide lateral support for the ob-  
15 jects to be carried. Instead of or in addition to a grip strip 25 of Fig. 3. According to one embodiment (not shown), the engagement member 20 has been designed to have a landscape providing recesses specifically shaped to receive and support a certain object, such as the bottom of a multipack-bottle carrier. As the engagement member 20 is made of formable material, it can be injection molded to conform to the current transportation  
20 need. Accordingly, no changes are necessary for the frame 10, which can be used as a modular load-bearing component. Furthermore, the engagement member 20 may be manufactured from a relatively soft material, which can deform elastically to form receive the object tightly while the frame 10 is adapted to bear the weight of the objects on the engagement member 20 and to provide support to the engagement member 20. If is  
25 desirable to use a very flexible material for the engagement member 20, it may be beneficial to provide the frame 10 with additional supporting longitudinal beams 12 between the terminal outlining beams 12. Alternatively, an adaptor 40 according to the second aspect of the invention (Figs. 10 to 13) can be used to support the engagement member 20.

30

*Table 1: List of reference numbers.*

<b>Number</b>	<b>Part</b>	<b>Number</b>	<b>Part</b>
1	dolly	20	engagement member
10	frame	21	engaging side
11	transverse beam	22	back side
12	longitudinal beam	23	wheel reception well
13	aperture	23a	chamfered wheel reception well
14	cribbing cavity	23b	rounded wheel reception well
15	screw	24	jointing sleeve
16	nut	25	grip strip
17	screw	30	wheel
18	counterpart	40	adapter
19	slit	41	receptacle

*Claims*

1. Dolly (1) for transportation of objects, the dolly (1) comprising:
  - an engagement member (20) made of formable material and having an engaging side (21) shaped for receiving carriers and a back side (22) opposite to the engaging side (21),
  - a plurality of wheels (30) bearing-mounted to the dolly (1) on opposite side to the engaging side (21),

**characterized** in that the dolly (1) comprises:

  - a load-bearing frame (10), to which the wheels (30) are mounted, and
  - an abutment between the frame (10) and the engagement member (20) for fastening the engagement member (20) to the frame (10),

whereby a single type of load-bearing frame (10) is applicable to a variety of engagement members (20).
2. Dolly (1) according to claim 1, wherein an interface for the objects is provided to the engaging side (21) and adapted to provide a form-fitting connection to the objects.
3. Dolly (1) according to claim 1 or 2, wherein the engagement member (20) is of polymer.
4. Dolly (1) according to claim 1, 2 or 3, wherein the frame (10) is of steel.
5. Dolly (1) according any of the preceding claims, wherein the frame (10) is of aluminum or carbon fiber.
6. Dolly (1) according any of the preceding claims, wherein the frame (10) is formed by an assembled beam structure and the engagement member (20) is molded, such as injection molded.
7. Dolly (1) according any of the preceding claims, wherein the abutment is provided between the frame (10) and the back side (22) of the engagement member (20).
8. Dolly (1) according to claim 7, wherein the abutment between the frame (10) and the back side (22) of the engagement member (20) is a detachable joint.

9. Dolly (1) according to claim 8, wherein the abutment between the frame (10) and the back side (22) of the engagement member (20) is a form-fitting joint, such as a screw joint.
- 5 10. Dolly (1) according any of the preceding claims, wherein the dolly (1) comprises an adaptor (40) fixed to the frame (10), the adaptor (40) being adapted to form a snap-fit joint (24, 41) between the frame (10) and the engagement member (20) for accommodating exchange of the engagement member (20).
- 10 11. Dolly (1) according any of the preceding claims, wherein the engaging side (21) of the engagement member (20) is provided with wheel reception wells (23) adapted to receive the wheel (30) of a superimposed second dolly (1) so that the well (23) and the wheel (30) share three contact points.
12. Frame assembly for a dolly (1) according to claim 1, **characterized** in that the frame assembly comprises a plurality of interconnectable beams (11, 12), which are adapted to be connected to each other by cribbing joints (13, 14, 19).
- 15 13. Frame assembly according to claim 12, wherein assembly comprises at least two mutually parallel longitudinal beams (12) and at least two mutually parallel transverse beams (11), which connect to the longitudinal beams (12) by cribbing joints (13, 14, 19) forming a rectangular frame (10).
- 20 14. Frame assembly of claim 12 or 13, wherein the assembly comprises wheels (30), which are fixed with screw joints to the joints between the beams (11, 12) of the frame (10) so that the screw joints secure also the engagement member (20) to the frame (10).
- 25 15. Frame assembly of claim 14, wherein the assembly comprises a longitudinal beam (12) provided to the center of the frame (10) and at least one transverse beam (11) fixed to each end of the central longitudinal beam (12) with cribbing joints (13, 14, 19), wherein the wheels (30) are attached to the terminal ends of the transverse beams (11).

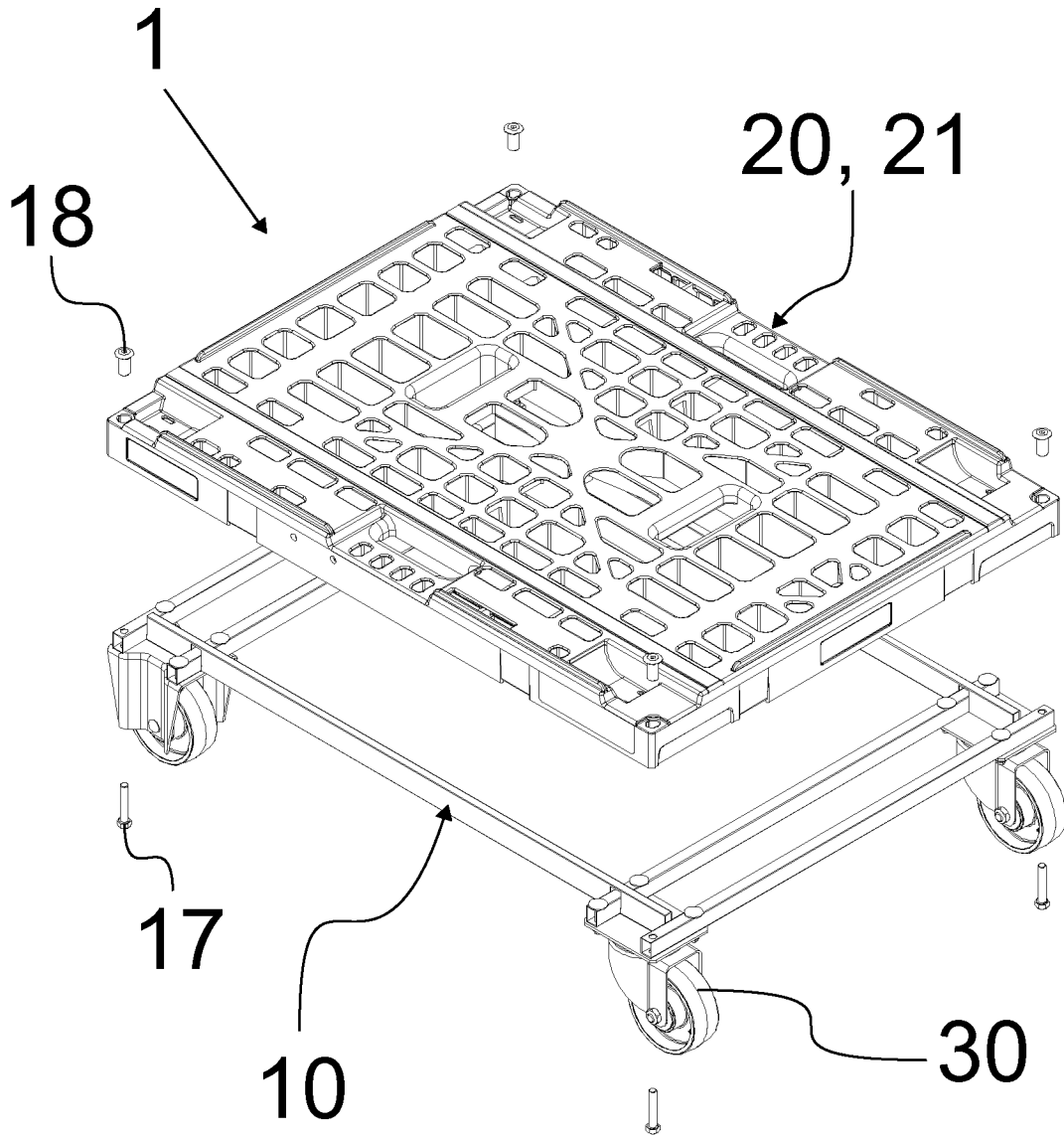

FIG. 1

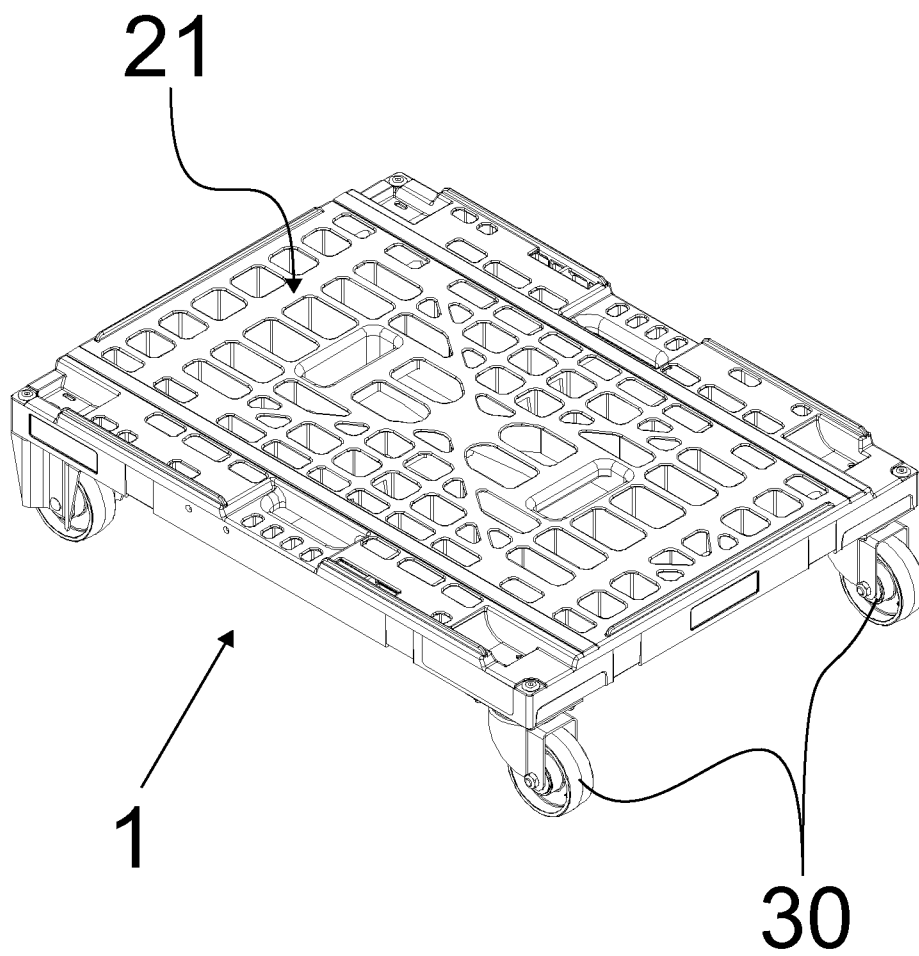

FIG. 2



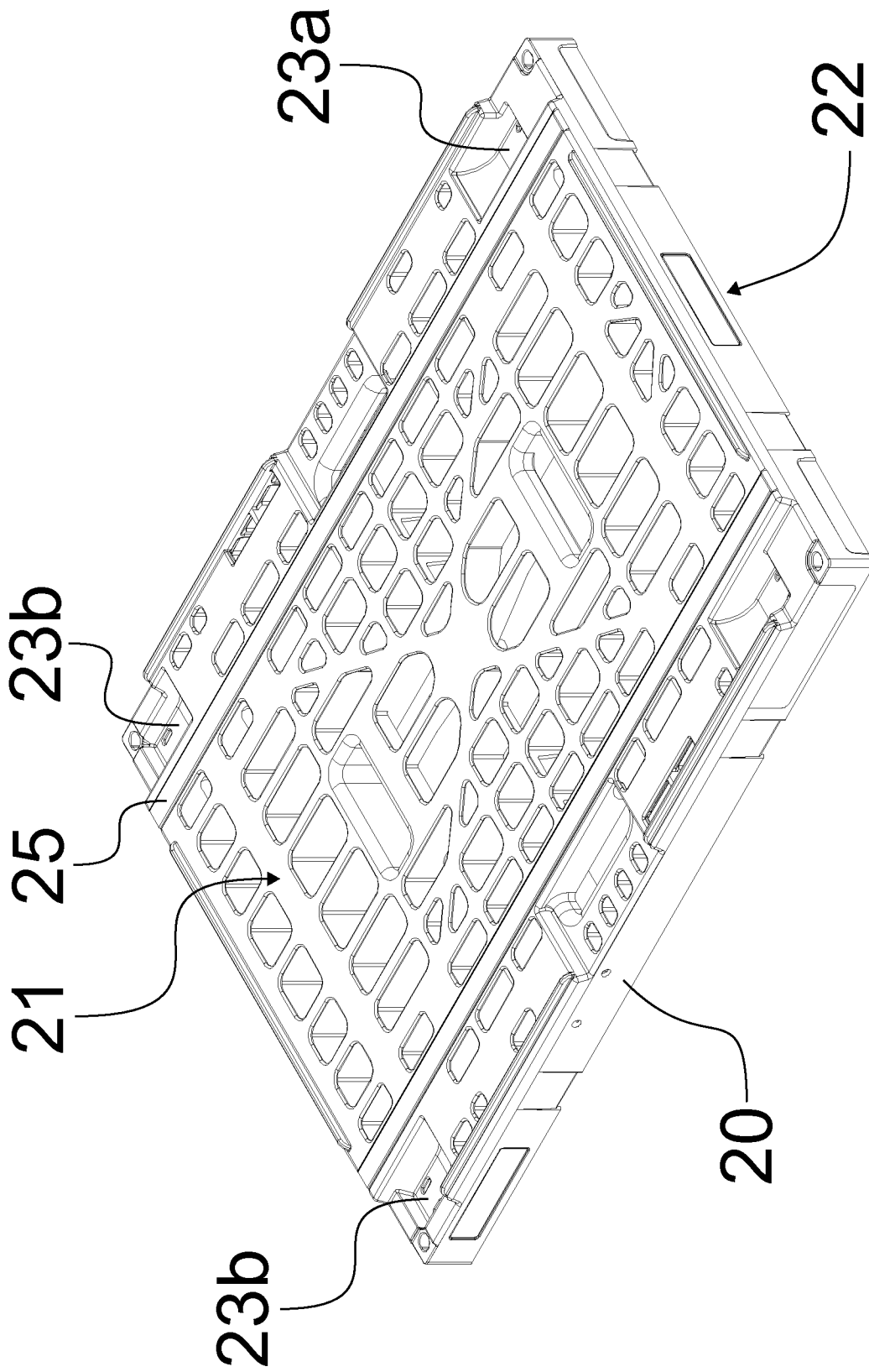

FIG. 3

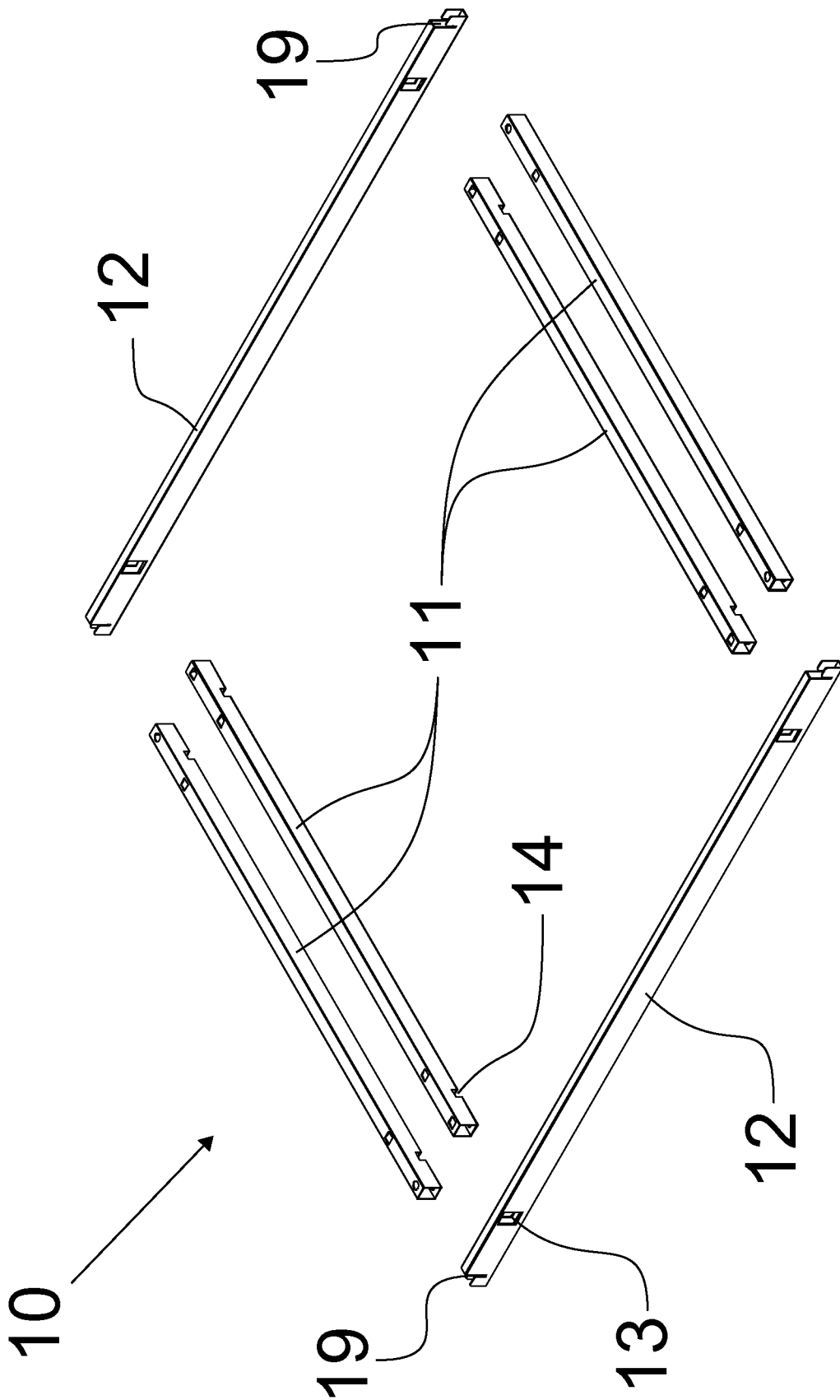

FIG. 4

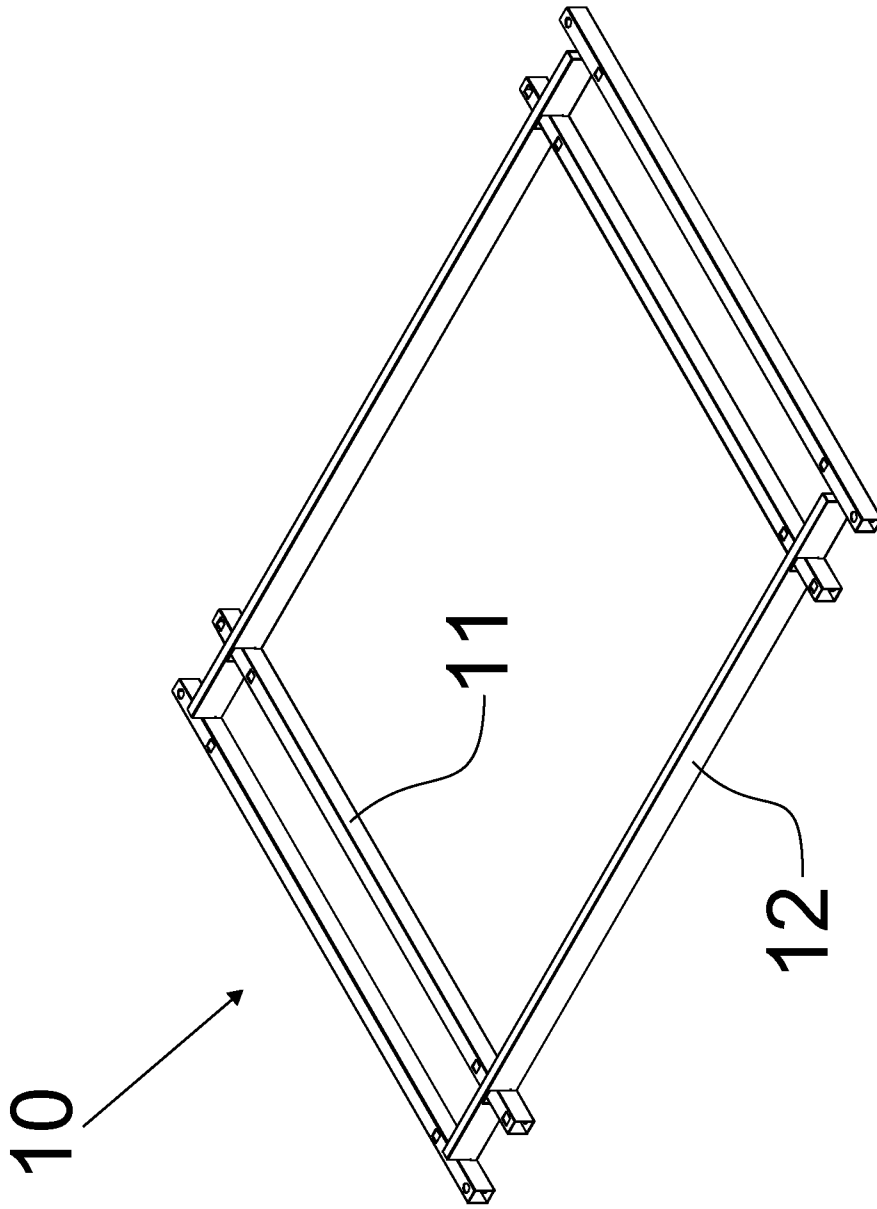

FIG. 5

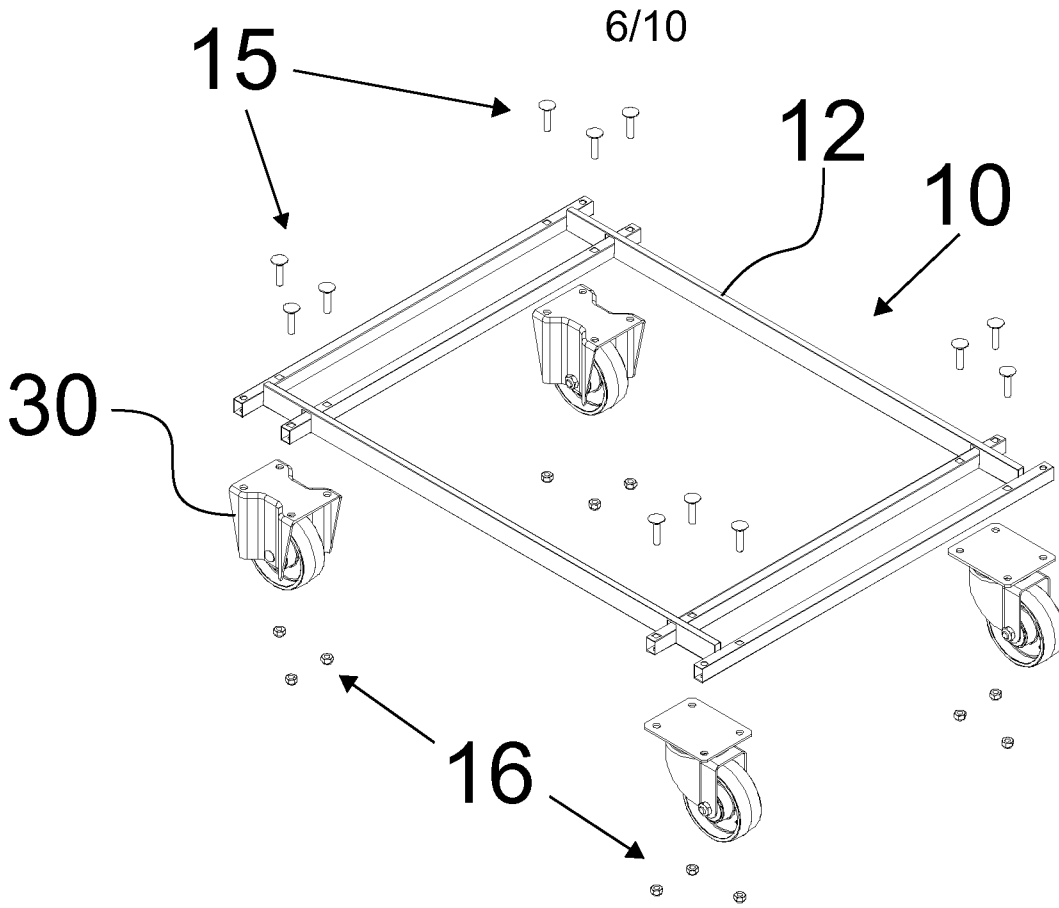

FIG. 6

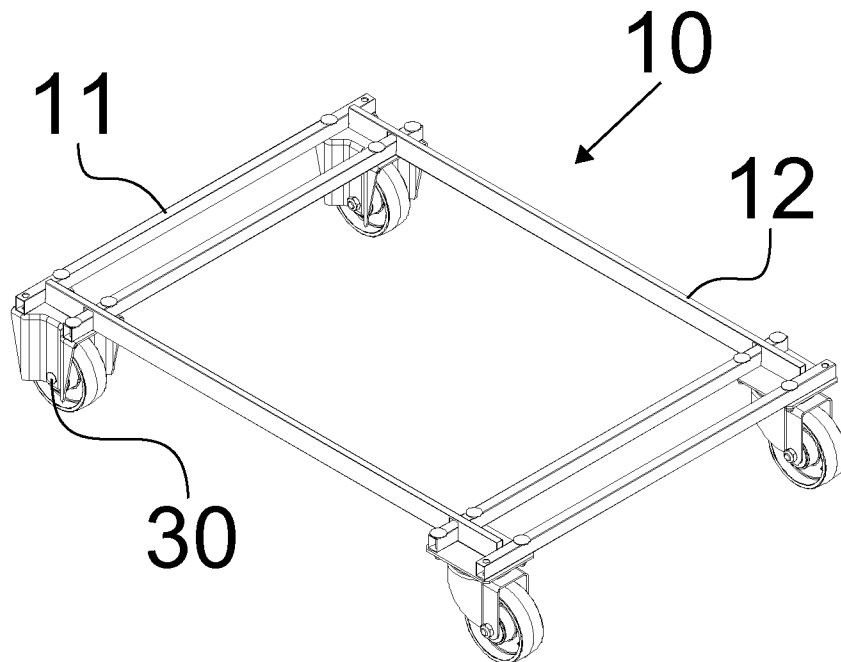

FIG. 7

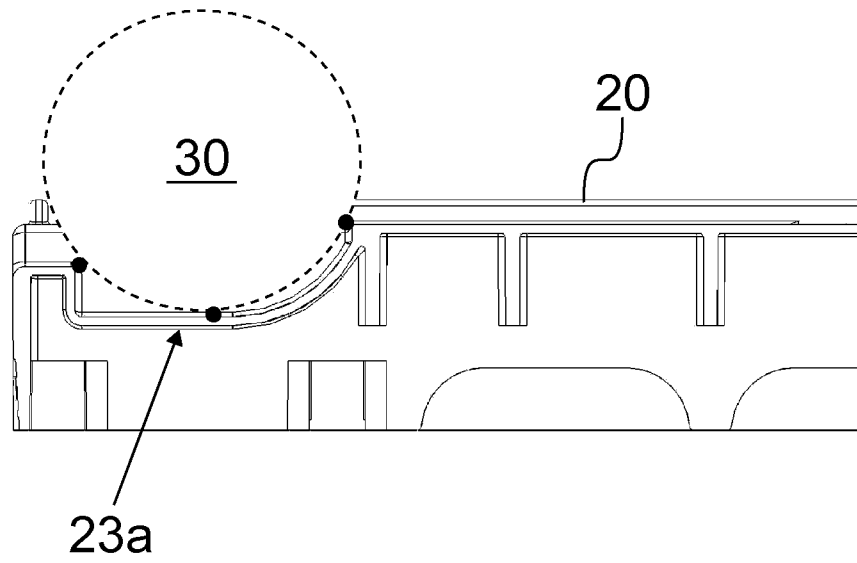

FIG. 8

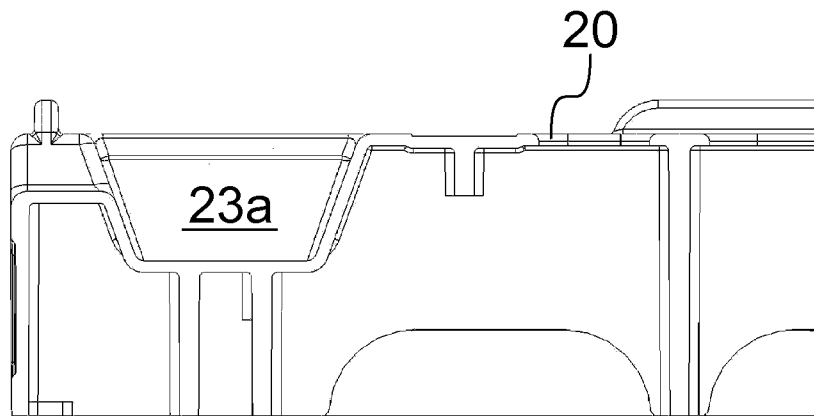

FIG. 9

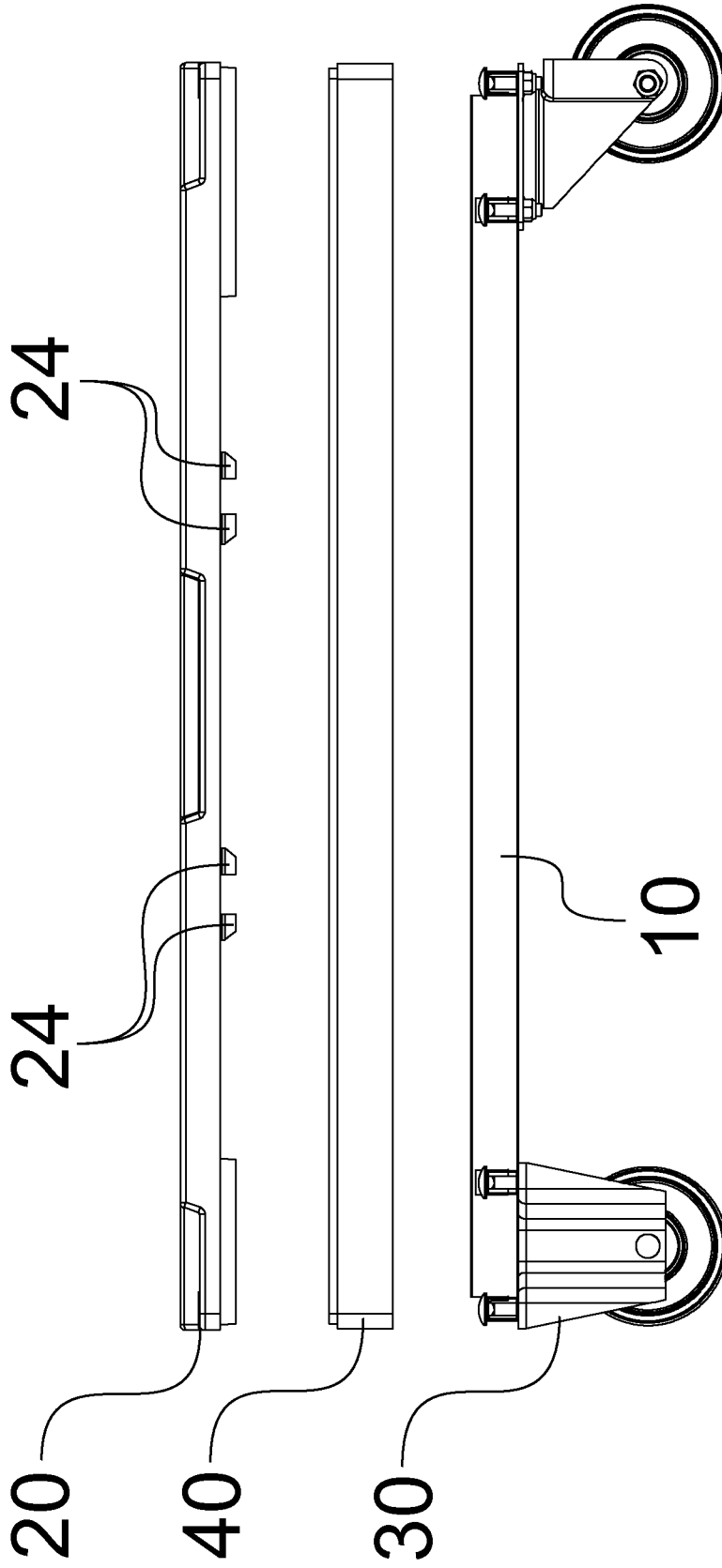

FIG. 10

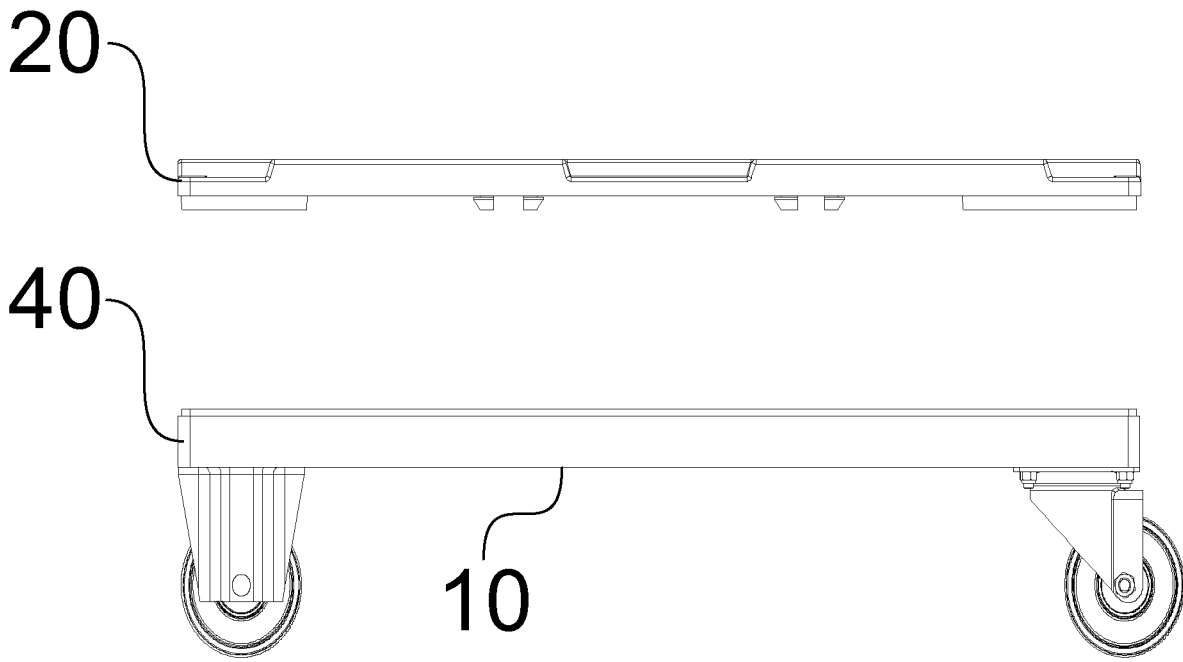

FIG. 11

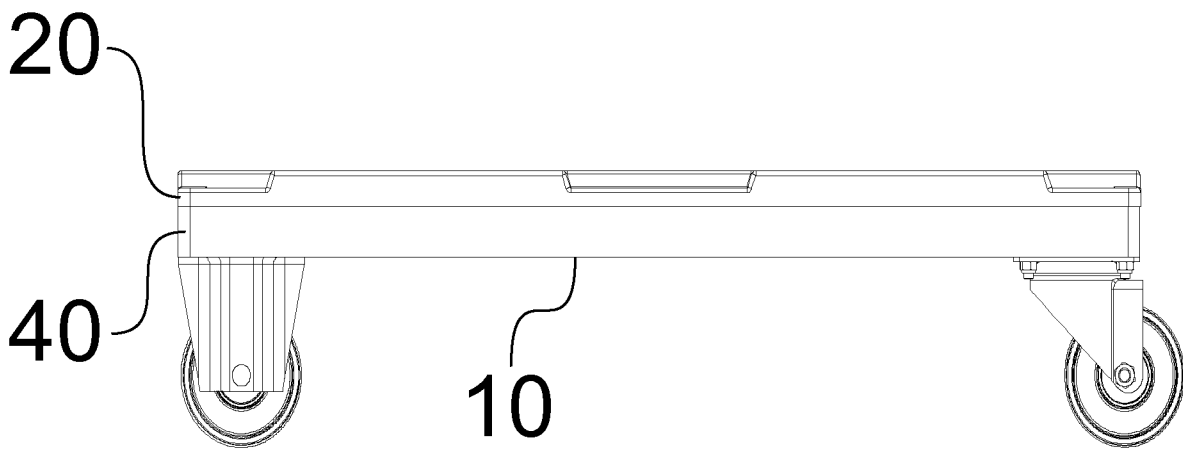

FIG. 12

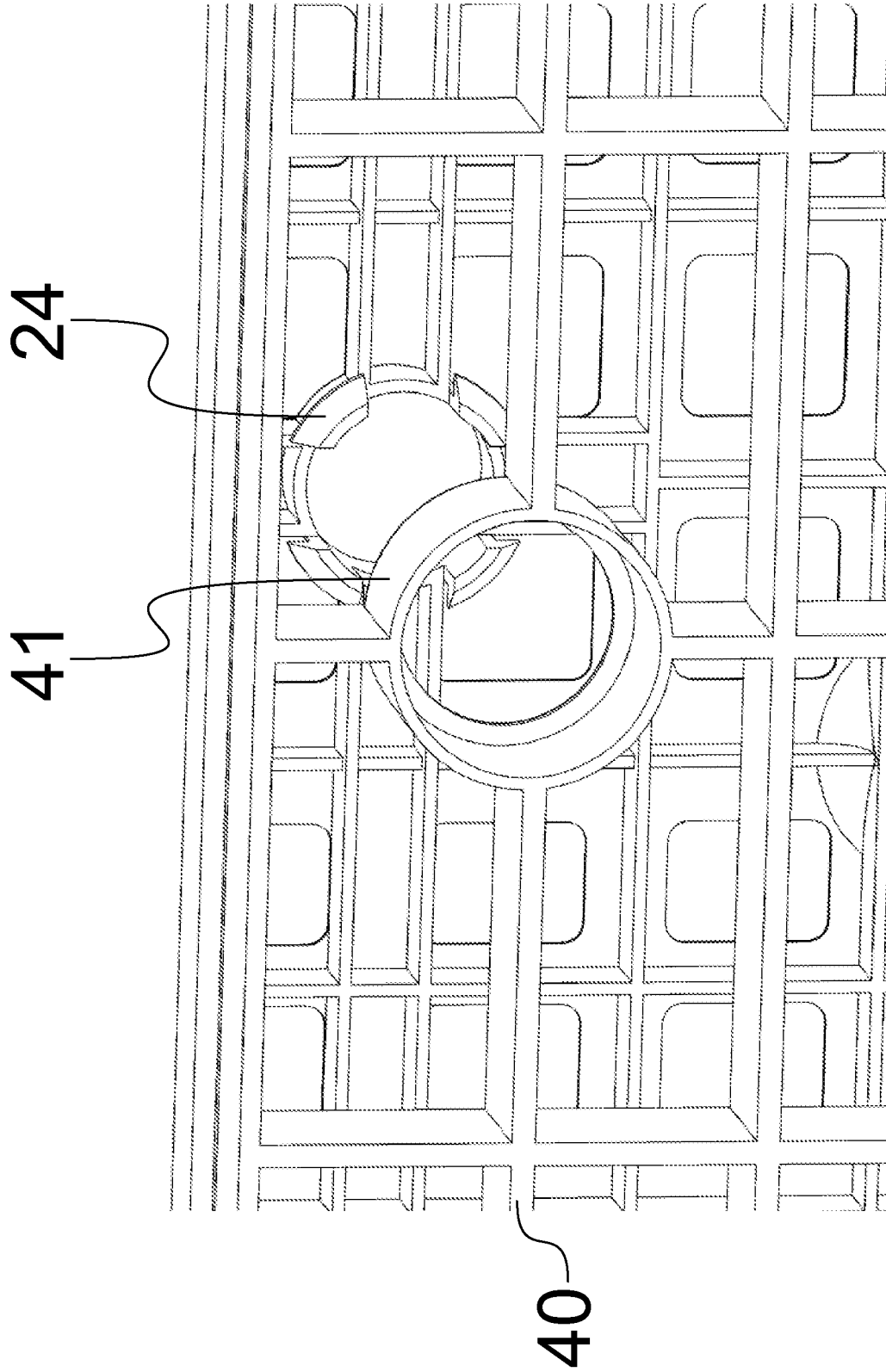

FIG. 13



## INTERNATIONAL SEARCH REPORT

International application No.

PCT/FI201 0/050574

## A. CLASSIFICATION OF SUBJECT MATTER

See extra sheet

According to International Patent Classification (IPC) or to both national classification and IPC

## B. FIELDS SEARCHED

Minimum documentation searched (classification system followed by classification symbols)

IPC: B62B, B65D, B65F, B65G

Documentation searched other than minimum documentation to the extent that such documents are included in the fields searched  
FI, SE, NO, DKElectronic data base consulted during the international search (name of data base and, where practicable, search terms used)  
EPO-Internal, WPI

## C. DOCUMENTS CONSIDERED TO BE RELEVANT

Category*	Citation of document, with indication, where appropriate, of the relevant passages	Relevant to claim No.
X Y	JP 5-891 49 U (?) 03 December 1993 (03.12.1993) figures 1 - 9	1-3, 6-9 4, 5, 10, 11
X	US 4969657 A (KAUFMANN DAVID W) 13 November 1990 (13.11.1990) figures 1 - 2; column 2, line 48 - column 4, line 12	12
X	US 2774609 A (WINGER RAYMOND C) 18 December 1956 (18.12.1956) figures 1 - 4; column 1, line 47 - column 2, line 14	12, 13
X Y	US 20081 11332 A 1 (NABATA YUTAKA) 15 May 2008 (15.05.2008) figures 1 - 6; paragraphs [0035] - [0039]	12, 13 4, 5, 14
X Y	JP 2005088607 A (YOSHIKE KAKEN KIKI KK et al.) 07 April 2005 (07.04.2005) abstract [online] EPOQUENET EPODOC & WPI; figures 1 - 11	12, 13 15
Y	US 200621 4384 A 1 (GWIN DAVID C) 28 September 2006 (28.09.2006) figures 1 - 5; paragraph [0026]	10



Further documents are listed in the continuation of Box C.



See patent family annex.

\* Special categories of cited documents:

"A" document defining the general state of the art which is not considered to be of particular relevance

"E" earlier application or patent but published on or after the international filing date

"L" document which may throw doubts on priority claim(s) or which is cited to establish the publication date of another citation or other special reason (as specified)

"O" document referring to an oral disclosure, use, exhibition or other means

"P" document published prior to the international filing date but later than the priority date claimed

"T" later document published after the international filing date or priority date and not in conflict with the application but cited to understand the principle or theory underlying the invention

"X" document of particular relevance; the claimed invention cannot be considered novel or cannot be considered to involve an inventive step when the document is taken alone

"Y" document of particular relevance; the claimed invention cannot be considered to involve an inventive step when the document is combined with one or more other such documents, such combination being obvious to a person skilled in the art

"&amp;" document member of the same patent family

Date of the actual completion of the international search

24 March 2011 (24.03.201 1)

Date of mailing of the international search report

28 March 201 1 (28.03.20 11)

Name and mailing address of the ISA/FI  
National Board of Patents and Registration of Finland  
P.O. Box 1160, FI-00101 HELSINKI, Finland

Facsimile No. +358 9 6939 5328

Authorized officer

Jorma Kana

Telephone No. +358 9 6939 500

## INTERNATIONAL SEARCH REPORT

International application No.

PCT/FI201 0/050574

C (Continuation). DOCUMENTS CONSIDERED TO BE RELEVANT		
Category*	Citation of document, with indication, where appropriate, of the relevant passages	Relevant to claim No.
Y	EP 1529733 A 1 (GEBHARDT TRANSPORT & LAGERSYS) 11 May 2005 (11.05.2005) paragraph [0016]; figures 1 - 4	11
Y	US 2004090029 A 1 (HARDESTY DOUGLAS S) 13 May 2004 (13.05.2004) abstract; figures 3, 4, 6 and 7	14
Y	US 2003030239 A 1 (WÖRNER AXEL G) 13 February 2003 (13.02.2003) figure 4	15

**INTERNATIONAL SEARCH REPORT**  
**Information on patent family members**

International application No.  
PCT/FI201 0/050574

Patent document cited in search report	Publication date	Patent family members(s)	Publication date
JP 5-891 49 U	03/1 2/1 993	None	
US 4969657 A	13/1 1/1 990	None	
US 2774609 A	18/1 2/1 956	None	
US 20081 11332 A 1	15/05/2008	JP 20081 20282 A	29/05/2008
JP 2005088607 A	07/04/2005	None	
US 200621 4384 A 1	28/09/2006	None	
EP 1529733 A 1	11/05/2005	DE 2031 7066U U1	08/0 1/2004
US 2004090029 A 1	13/05/2004	None	
US 2003030239 A 1	13/02/2003	None	

INTERNATIONAL SEARCH REPORT

International application No.

PCT/FI201 0/050574

CLASSIFICATION OF SUBJECT MATTER

Int.Cl.

**B62B 3/02** (2006.01 )

**B62B 5/00** (2006.01 )

**B65D 19/42** (2006.01 )