

(19) World Intellectual Property Organization
International Bureau



(43) International Publication Date
28 February 2002 (28.02.2002)

PCT

(10) International Publication Number
WO 02/16734 A1

- (51) International Patent Classification⁷: E21B 43/017, 43/013
- (74) Agents: JOHNSTONE, Douglas, Ian et al.; Baron & Warren, 18 South End, Kensington, London W8 5BU (GB).
- (21) International Application Number: PCT/GB01/03731
- (81) Designated States (*national*): AE, AG, AL, AM, AT, AU, AZ, BA, BB, BG, BR, BY, BZ, CA, CH, CN, CO, CR, CU, CZ, DE, DK, DM, DZ, EC, EE, ES, FI, GB, GD, GE, GH, GM, HR, HU, ID, IL, IN, IS, JP, KE, KG, KP, KR, KZ, LC, LK, LR, LS, LT, LU, LV, MA, MD, MG, MK, MN, MW, MX, MZ, NO, NZ, PH, PL, PT, RO, RU, SD, SE, SG, SI, SK, SL, TJ, TM, TR, TT, TZ, UA, UG, US, UZ, VN, YU, ZA, ZW.
- (22) International Filing Date: 17 August 2001 (17.08.2001)
- (25) Filing Language: English
- (26) Publication Language: English
- (30) Priority Data:
0020460.2 18 August 2000 (18.08.2000) GB
- (84) Designated States (*regional*): ARIPO patent (GH, GM, KE, LS, MW, MZ, SD, SL, SZ, TZ, UG, ZW), Eurasian patent (AM, AZ, BY, KG, KZ, MD, RU, TJ, TM), European patent (AT, BE, CH, CY, DE, DK, ES, FI, FR, GB, GR, IE, IT, LU, MC, NL, PT, SE, TR), OAPI patent (BF, BJ, CF, CG, CI, CM, GA, GN, GQ, GW, ML, MR, NE, SN, TD, TG).
- (71) Applicant (*for all designated States except US*): ALPHA THAMES LTD [GB/GB]; Essex House, Station Road, Upminster, Essex RM14 2SU (GB).
- (72) Inventors; and
- (75) Inventors/Applicants (*for US only*): APPLEFORD, David, Eric [GB/GB]; 5 Greenview Cottages, Theydon Bois, Epping, Essex CM16 7JD (GB). LANE, Brian, William [GB/GB]; 41 Rattwick Drive, Canvey Island, Essex SS8 8NF (GB).

Declarations under Rule 4.17:

— *as to applicant's entitlement to apply for and be granted a patent (Rule 4.17(ii)) for the following designations AE, AG, AL, AM, AT, AU, AZ, BA, BB, BG, BR, BY, BZ, CA, CH,*

[Continued on next page]

(54) Title: MODULAR SEABED PROCESSING SYSTEM

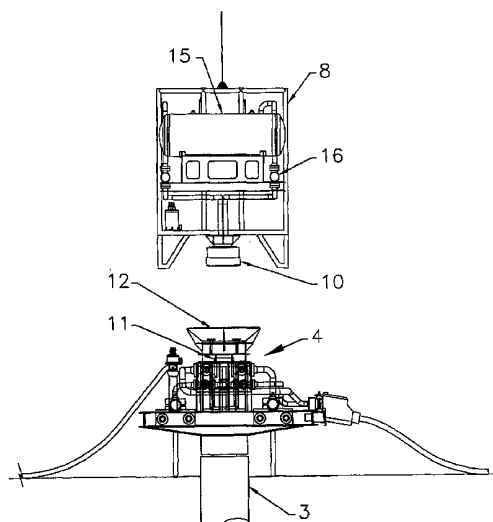

(57) Abstract: To install a modular seabed processing system (1) on a seabed, a monopile foundation (3) is first lowered down and driven into the seabed. A docking unit (4) is lowered towards the installed foundation (3) so that a mating clamp system (6) mounted on the docking unit is aligned with a spigot (5) on the foundation. The clamp system then clamps the spigot to fix the docking unit onto the foundation. Flowlines (2) and an electrical power connector plug (18) are connected to the docking unit. A first retrievable substantially autonomous module (8) is lowered and connected to the docking unit (4) by a multi-bored connector (10, 11) and the plug (18) on the docking unit is engaged by a corresponding socket (17) on the module. Isolation valves (14, 16) in the docking unit and module are opened so that the module (8) is able to act on fluid received from the flowlines (2) via the multi-bored connector (10, 11). A second retrievable substantially autonomous module is also connected to the docking unit (4) in the same way.



WO 02/16734 A1



CN, CO, CR, CU, CZ, DE, DK, DM, DZ, EC, EE, ES, FI, GB, GD, GE, GH, GM, HR, HU, ID, IL, IN, IS, JP, KE, KG, KP, KR, KZ, LC, LK, LR, LS, LT, LU, LV, MA, MD, MG, MK, MN, MW, MX, MZ, NO, NZ, PH, PL, PT, RO, RU, SD, SE, SG, SI, SK, SL, TJ, TM, TR, TT, TZ, UA, UG, UZ, VN, YU, ZA, ZW, ARIPO patent (GH, GM, KE, LS, MW, MZ, SD, SL, SZ, TZ, UG, ZW), Eurasian patent (AM, AZ, BY, KG, KZ, MD, RU, TJ, TM), European patent (AT, BE, CH, CY, DE, DK, ES, FI, FR, GB, GR, IE, IT, LU, MC, NL, PT, SE, TR), OAPI patent (BF, BJ, CF, CG, CI, CM, GA, GN, GQ, GW, ML, MR, NE, SN, TD, TG)

— of inventorship (Rule 4.17(iv)) for US only

Published:

— with international search report

For two-letter codes and other abbreviations, refer to the "Guidance Notes on Codes and Abbreviations" appearing at the beginning of each regular issue of the PCT Gazette.

MODULAR SEABED PROCESSING SYSTEM

The present invention relates to a system suitable for exploiting oil/gas
5 fields and, more particularly, subsea fields and a method of installing such a
system.

Conventional oil/gas fields have a plurality of wells linked to a host
facility which receives the oil/gas via flow lines. A conventional underwater
oil/gas field may include modularised processing systems between the wells
10 and the host facility.

GB 2261271 describes a modularised processing system which is used
to separate a mixture of oil, gas and water from wells into its individual
components. The system comprises an offshore installation in which
interchangeable modules are individually supported in a support framework
15 located on the seabed, the modules being used to separate the mixture. Two-
part connectors enable modules to be lowered from the surface of the sea into
the framework and be connected up to the wells. The modules can also be
retrieved from the system so that maintenance can be carried out on them
when they are out of the water.

20 Such a framework is a large, heavy structure which requires expensive
guidance means for guiding the modules into the framework.

It is therefore an object of the present invention to provide an improved
system for such modules and a method of installation of such a system.

According to one aspect of the present invention there is provided a
25 method of installing a system, comprising the steps of:

installing a foundation into ground;

fixing a docking unit to the foundation via a single connection;

connecting flowlines to the docking unit; and

30 connecting at least one retrievable substantially autonomous module to the
docking unit so that the or each module is able to act on fluid received from

the flowlines.

By having a single connection between the docking unit and the foundation, the installation of the docking unit is made far simpler. The single connection may comprise a connection of a type used for a well head.

5 The step of fixing the docking unit to the foundation via a single connection may comprise clamping a mating clamp arrangement attached to one of the docking unit or the foundation to a protrusion attached to the other of the docking unit or foundation. The protrusion is preferably substantially centrally placed on the docking unit or foundation.

10 The step of connecting at least one retrievable substantially autonomous module to the docking unit desirably includes actuating isolation means to connect at least one module to the flowlines, the isolation means comprising a first portion in the module and a complementary second portion in the docking unit.

15 The method may include an uninstalling step of disconnecting one said retrievable substantially autonomous module from the docking unit, without affecting the operation of any other retrievable substantially autonomous module with the flowlines and without effecting the connection of any other such module. The uninstalling step desirably includes actuating the isolation
20 means to isolate the module being disconnected from the docking unit and the flowlines connected thereto.

The isolation means may comprise an isolation connector of a type used for a well head. The isolation means may comprise a multi-ported valve isolation connector.

25 It may be desirable for the method to include the steps of connecting a first portion of a power connector to the docking unit, the first portion of the power connector being connected to a power source remote from the docking unit, and connecting a complementary second portion of the power connector in one said retrievable substantially autonomous module to the first portion so
30 that the power source is able to provide power to the module. The power

connector may be adapted to carry control signals to or from the module.

The step of connecting at least one retrievable substantially autonomous module to the docking unit may include providing guiding means to guide said module into connection with the docking unit. The guiding means desirably ensures that the second portion of the power connector of the module engages the first portion of the power connector on the docking unit.

The ground is preferably a seabed. The foundation may comprise a single pile.

10 According to another aspect of the present invention there is provided a system comprising:

a foundation installed into ground;

a docking unit fixed to the foundation via a single connection; and

15 at least one retrievable substantially autonomous module, the or each module being connected to the docking unit so that the or each module is able to act on fluid received from the flowlines.

The system has a much smaller "footprint" on, say, a seabed, and is also lighter and cheaper than a system having a support framework for interchangeable modules.

20 Embodiments of the present invention will now be described, by way of example, with reference to the accompanying drawings, in which:-

Figures 1 and 2 are side elevations of a system, according to one embodiment of the invention;

25 Figures 3 to 17 are side elevations showing the installation of the system; and

Figures 18 to 23 are side elevations showing modifications to the foundations for the system.

Referring to Figures 1 and 2 of the accompanying drawings, a modular seabed processing system 1 is illustrated which is connected by underwater flowlines 2 to wells (not shown) which remove a fluid mixture comprising

30

water and oil/gas from reservoirs beneath the seabed. The system comprises a monopile foundation 3 to which a docking unit or manifold 4 is connected. A spigot 5 (see Figure 3) projects upwardly from the centre of the head of the pile 3 and is clamped by a mating clamp system 6 mounted to the base of the docking unit 4. The spigot 5 is an integral part of the pile 3.

The flowlines 2 from the wells are connected to the docking unit 4 and pipelines or flowlines 7 connect the docking unit 4 to a host facility (not shown). The host facility may be, for example, onshore or on a fixed or a floating rig.

Also connected to the docking unit 4 is a pair of retrievable substantially autonomous modules 8,9. Each module 8,9 has a first portion 10 of a multi-bored connector (see also Figures 12 and 13) at its base which is connected to a complementary second portion 11 of the multi-bored connector (see also Figures 6 and 7) mounted on top of the docking unit 4, each multi-bored connector has a guidance cone 12 surrounding it for alignment purposes when a module is installed on the docking unit. Pipework 13 is provided within the docking unit 4 to connect the flowlines 2 and the pipelines 7 to the second portion 11 of the multi-bored connector. The pipework has isolation valves 14.

Each retrievable substantially autonomous module 8,9 has a separator chamber 15 for separating fluids from the fluid mixture. The separator chamber 15 is connected to the first portion 10 of the multi-bored connector via isolation valves 16.

Each module 8,9 has an electric power connector socket 17 engaged with a corresponding plug 18 attached to the docking unit 4. Each plug 18 is connected to an integrated umbilical 19 from the host facility. The umbilicals 19 are adapted to provide power, control signals and chemical injection from the host facility to the modules 8,9. The control signals are sent to control, reprogramme or shut down the modules 8,9 which are otherwise self-controlling during normal running. The chemicals are injected into the modules

8,9 as part of their normal operation or as a result of a planned or unplanned shut down to prevent unwanted chemical reactions such as hydrate formation, wax deposition and corrosion. Each module 8,9 also has stab connectors (not shown) for connecting to corresponding stab connectors (not shown) on the docking unit 4 so that the module is able to receive the chemical injection.

Referring to Figures 3 to 17, the process of installation of the system on a seabed will now be described.

The monopile foundation 3 is lowered down to the seabed and driven into the seabed in a conventional manner. Figure 3 shows it installed.

The isolation valves 14 in the pipework 13 in the docking unit 4 are set to closed positions.

[Figures 4 and 5] The docking unit 4 is placed in installation rigging 20 which is lowered from a surface vessel towards the monopile foundation 3.

[Figures 6 and 7] The mating clamp system 6 mounted on the base of the docking unit is approximately aligned with the spigot 5, the mating clamp system being then remotely activated by, say, a remotely operated vehicle (ROV), so as to clamp the spigot, fixing the docking unit 4 to the monopile foundation 3.

[Figures 8 and 9] Pipeline connectors 21 at the end of the pipelines 7 from the host facility are connected to the docking unit 4 and flowline connectors 22 at the end of flowlines 2 from the wellheads are connected to the docking unit in a conventional manner by, say, ROVs or remotely operated tools (ROTs).

[Figures 10 and 11] The electrical power connector plug 18 at the end of the umbilical 19 from the host facility is attached to the docking unit 4 in a conventional manner by being lowered from the surface vessel.

Before a first retrievable substantially autonomous module 8 is lowered from, for example, the surface vessel towards the docking unit 4, the module isolation valves 16 are set to closed positions. Systems in the module 8 are rigorously tested before the module is lowered.

[Figures 12 and 13] The first retrievable substantially autonomous module 8 is then lowered towards the docking unit 4.

The first portion 10 of the multi-bored connector at the base of the module 8 is approximately aligned with one of the guidance cones 12 on the docking unit 4. The cone 12 guides the first portion 10 into specific alignment with the complementary second portion 11 of the multi-bored connector.

[Figures 14 and 15] When the first and second portions 10,11 of the multi-bored connector 11 are correctly aligned, this causes the electrical power connector socket 17 of the module 8 to be specifically aligned with a corresponding electrical power connector plug 18 on the docking unit 4. Thus, the two portions 10,11 of the multi-bored connector engage and the plug 18 and socket 17 engage.

[Figures 16 and 17] A second retrievable autonomous module 9 is lowered and installed on the docking unit 4 in the same way.

Referring back to Figures 1 and 2, in use, the docking unit isolation valves 14 and the module isolation valves 16 are opened. Fluid mixture from the wells is received into the module separator chambers 15 via the flowlines 2 and the open isolation valves 14,16. The fluid mixture is separated into gas and liquid by the module separator chambers 15. The separated gas and liquid are then transported by the pipelines 7 to the host facility.

To retrieve one of the modules from the seabed processing system 1, that module 8 needs to be uninstalled. The module 8 to be disconnected is isolated from the rest of the seabed processing system 1 by closing the isolation valves 14 in the pipework 13 to the second portion of the multi-bored connector 11 for that module 8 and the isolation valves 16 in that module. The module 8 is then retrieved without affecting the connection of the other module 9 in the system. Hence, the production operation of the other module 9 is not disturbed. Thus, a module may be easily retrieved for maintenance/repair purposes.

A module may be retrieved so that it can be reconfigured for another use. A module may not have a separator chamber but may, for example, be configured to simply manifold or pump fluid mixture received from the connected wells.

5 In a modification shown in Figures 18 and 19, the monopile foundation has been replaced by a caisson pile base foundation which also has a centrally placed spigot 5, projecting upwardly from the head of the foundation, for being clamped by the mating clamp system 6 at the base of the docking unit 4 when it is lowered onto it by an installation frame 20.

10 In another modification shown in Figures 20 and 21, the monopile foundation has been replaced by a suction base foundation 25. This comprises a number of compartments 26 attached to the underside of a framework 27, wherein water is pumped out of the compartments to draw them into the seabed. The framework 27 has a centrally placed spigot 5
15 projecting upwardly therefrom. This spigot 5 is also adapted to being clamped by the mating clamp system 6 at the base of the docking unit 4 when it is lowered onto it by an installation frame 20.

In yet another modification shown in Figures 22 and 23, the monopile foundation has been replaced by a mechanically locked pile foundation 29.
20 This comprises a number of piles 30 installed in the seabed with a framework 31 surrounding the top portion of the piles. The piles 30 are then mechanically locked to the framework 31, such as by expanding the outer tube of each pile 30 so that it forcefully engages the surrounding framework 31. The framework 31 has a centrally placed spigot 5 projecting upwardly
25 therefrom which is adapted to be clamped by the mating clamp 6 system at the base of the docking unit 4 when it is lowered onto it by an installation frame 20.

A system according to the invention is capable of operating at large "step-out" distances such as over 50 Km from a host facility and in deep
30 water. Therefore, less host facilities are required to exploit a particular field

and the life of a host facility can be extended by connecting it to remote satellite fields. Furthermore the system permits abandoned fields to be reopened and marginal fields to be exploited.

5 The system may use connecting means used for a well head for connecting the docking unit 4 to the foundation 3. The multi-bored connector 10,11 may comprise other connecting means used for a well head. The multi-bored connector may be a multi-bored valve isolation connector, such as the one described in GB 2261271.

10 Whilst a particular embodiment has been described, it will be understood that various modifications may be made without departing from the scope of the invention. For example, any suitable number of seabed processing systems may be used in a field.

The docking unit may be designed to hold any suitable number of retrievable substantially autonomous modules.

15 The pipelines between the seabed processing systems and the host facility may carry any suitable component separated from the fluid mixture extracted by wells.

20 The integrated umbilical may be replaced with separate power, control signal and chemical injection lines. Separate power and control signal lines may be replaced by an integrated power/control line.

The system may be land-based and not underwater.

CLAIMS:

1. A method of installing a system (1), comprising the steps of:
installing a foundation (3) into ground;
5 fixing a docking unit (4) to the foundation via a single connection (5,6);
connecting at least one flowline (2) to the docking unit; and
connecting at least one retrievable substantially autonomous module
(8,9) to the docking unit so that the or each module is able to act on fluid
received from the or each flowline.
10
2. A method as claimed in claim 1, wherein the step of fixing the docking
unit (4) to the foundation (3) via a single connection (5,6) comprises clamping
a mating clamp arrangement (6) attached to one of the docking unit or the
foundation to a protrusion (5) attached to the other of the docking unit or
15 foundation.
3. A method as claimed in claim 1 or 2, wherein the step of connecting at
least one retrievable substantially autonomous module (8,9) to the docking unit
(4) includes actuating isolation means (10,11) to connect at least one module
20 to said at least one flowline (2), the isolation means comprising a first portion
(10) in the module and a complementary second portion (11) in the docking
unit.
4. A method as claimed in claim 1, 2 or 3, including an uninstalling step of
25 disconnecting one said retrievable substantially autonomous module (8) from
the docking unit (4), without affecting the operation of any other retrievable
substantially autonomous module (9) and without effecting the connection of
any other such module (9) with said at least one flowline (2).
- 30 5. A method as claimed in claims 3 and 4, wherein the uninstalling step

includes actuating the isolation means (10,11) to isolate the module (8) being disconnected from the docking unit (4) and said at least one flowline (2) connected thereto.

5 6. A method as claimed in any preceding claim, including the steps of connecting a first portion (18) of a power connector (17,18) to the docking unit (4), the first portion of the power connector being connected to a power source remote from the docking unit, and connecting a complementary second portion (17) of the power connector comprising part of one said retrievable
10 substantially autonomous module (8) to the first portion (18) so that the power source is able to provide power to the module.

7. A method as claimed in any preceding claim, wherein the step of connecting at least one retrievable substantially autonomous module (8,9) to
15 the docking unit (4) includes providing guiding means (12) to guide said at least one module into connection with the docking unit.

8. A method as claimed in claims 6 and 7, wherein the guiding means (12) ensures that the second portion (17) of the power connector engages the first
20 portion (18) of the power connector.

9. A method as claimed in any preceding claim, including the step of connecting at least one outlet flowline (7) to the docking unit (4) for receiving fluid acted upon by said at least one module (8,9).
25

10. A method as claimed in claim 2 or any claim dependent thereon, wherein the protrusion (5) is substantially centrally placed on the docking unit (4) or foundation (3).

30 11. A method as claimed in claim 6 or any claim dependent thereon,

wherein the power connector is adapted to carry control signals to or from the module.

12. A method as claimed in any preceding claim, wherein the single
5 connection (5,6) comprises a connection of a type used for a well head.

13. A method as claimed in claim 3 or any claim dependent thereon,
wherein the isolation means (10,11) comprises an isolation connector of a type
used for a well head.

10

14. A method as claimed in claim 3 or any claim dependent thereon,
wherein the isolation means (10,11) comprises a multi-ported valve isolation
connector.

15. A method as claimed in any preceding claim, wherein the foundation (3)
15 comprises a single pile.

16. A method as claimed in any preceding claim, wherein the ground is a
seabed.

20

17. A system (1) comprising:
a foundation (3) installed into ground;
a docking unit (4) fixed to the foundation via a single connection (5,6);
and

25 at least one retrievable substantially autonomous module (8), the or each
module being connected to the docking unit so that the or each module is able
to act on fluid received from at least one flowline (2) when said at least one
flowline is connected to the docking unit (4).

30 18. A system as claimed in claim 17, wherein the single connection

comprises a mating clamp arrangement (6) attached to one of the docking unit (4) or the foundation (3) clamped to a protrusion (5) attached to the other of the docking unit or foundation.

- 5 19. A system as claimed in claim 17 or 18, including isolation means comprising a first portion (10) in one said module (8,9) and a complementary second portion (11) in the docking unit (4), the isolation means adapted to be actuated to connect one said module to said at least one flowline (2).
- 10 20. A system as claimed in claim 17, 18 or 19, including a power connector comprising interconnectable first and second portions, the first portion (18) being connected to the docking unit (4), and the second portion (17) comprising part of one said retrievable substantially autonomous module (8,9).
- 15 21. A system as claimed in claim 20, wherein the power connector (18,17) is adapted to carry control signals to or from the module (8,9).
- 20 22. A system as claimed in any one of claims 17 to 21, including guiding means (12) for guiding said at least one module into connection with the docking unit (4).
23. A system as claimed in claim 20 and 22, wherein the guiding means (12) is adapted to enable the first and second portions (18,17) of the power connector to engage.
- 25 24. A system as claimed in claim 18 or any claim dependent thereon, wherein the protrusion (5) is substantially centrally placed on the docking unit (4) or foundation (3).
- 30 25. A system as claimed in any one of claims 17 to 24, wherein the single

connection (5,6) comprises a connection of a type used for a well head.

26. A system as claimed in claim 19 or any claim dependent thereon,
wherein the isolation means (10,11) comprises an isolation connector of a type
5 used for a well head.

27. A system as claimed in claim 19 or any claim dependent thereon,
wherein the isolation means (10,11) comprises a multi-ported valve isolation
connector.

10

28. A system as claimed in any one of claims 17 to 27, wherein the
foundation (3) comprises a single pile.

Fig. 2

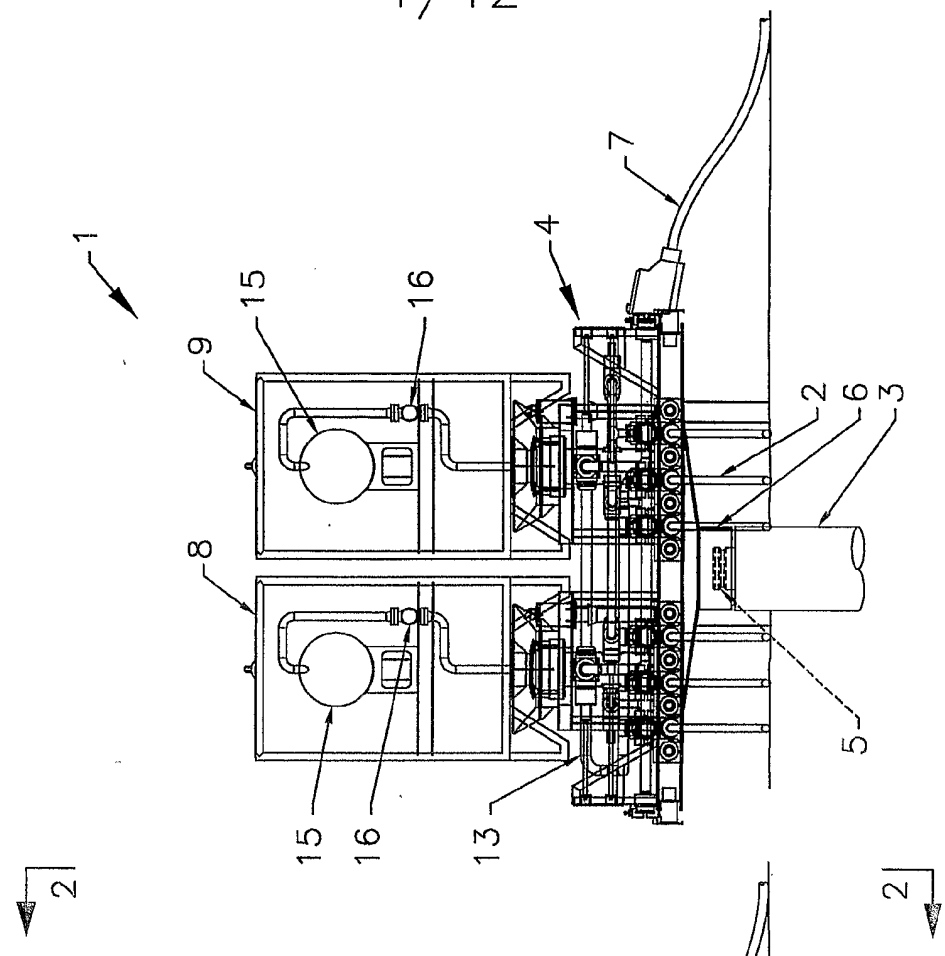

Fig. 1

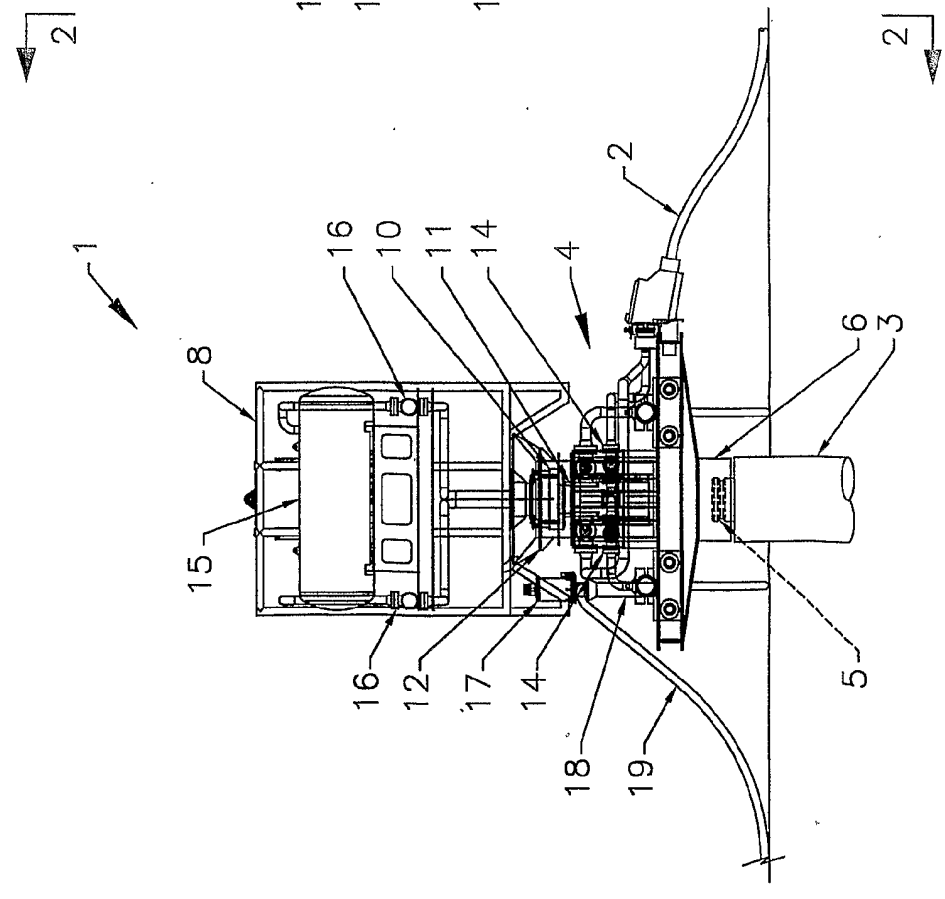

Fig. 3

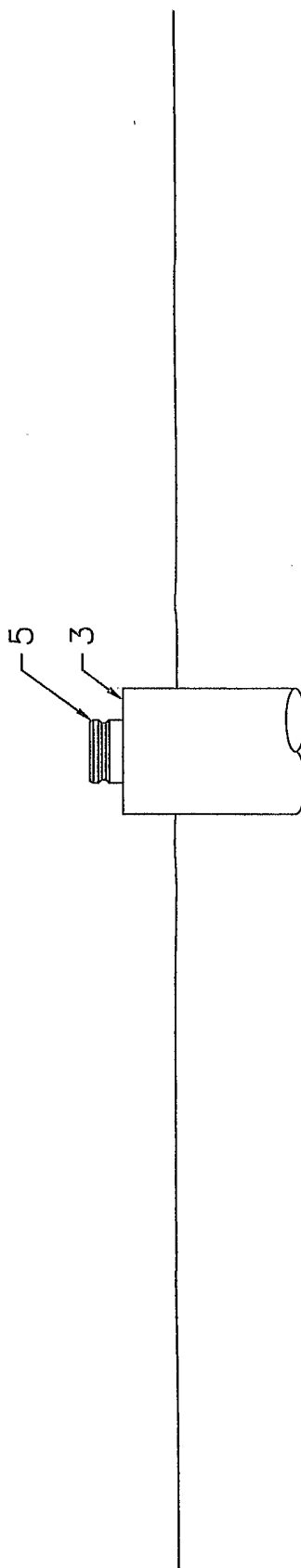

Fig. 5

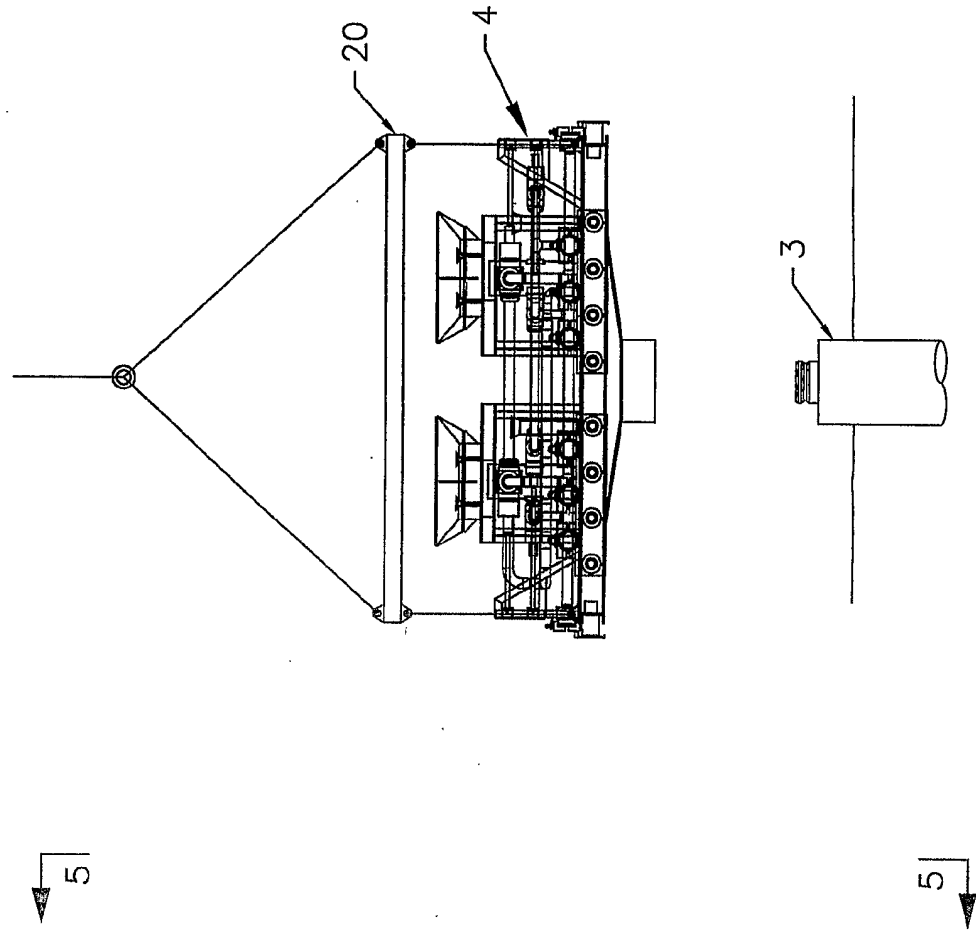

Fig. 4

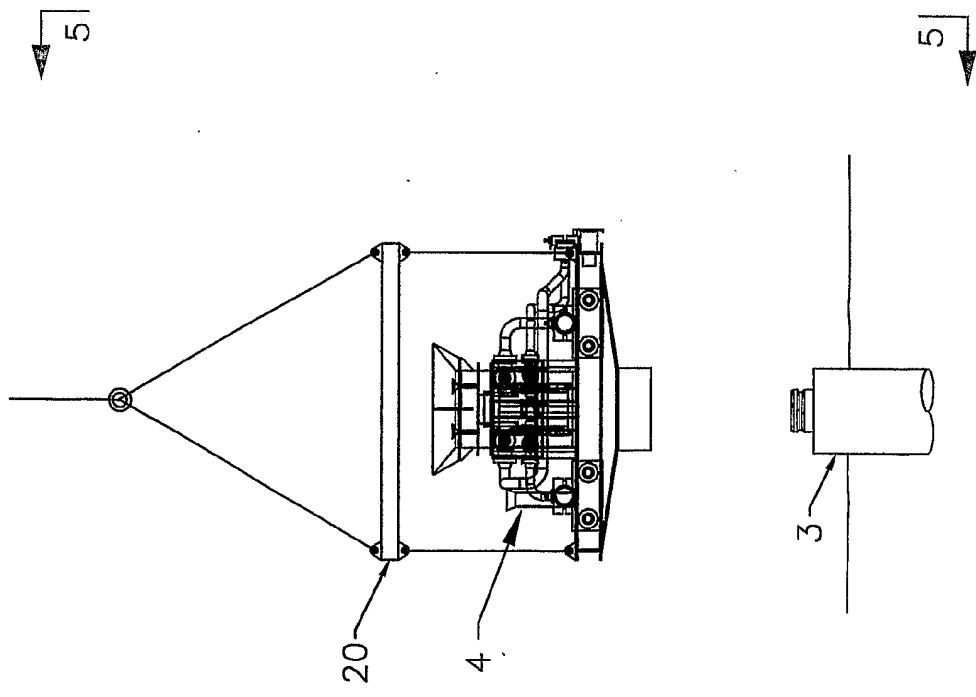

Fig. 6

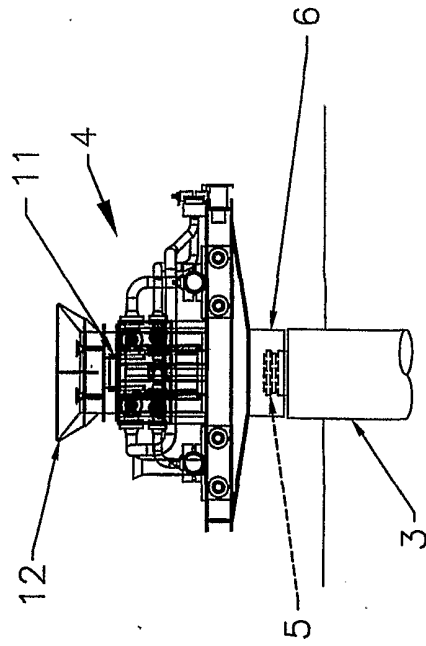

Fig. 7

4/12

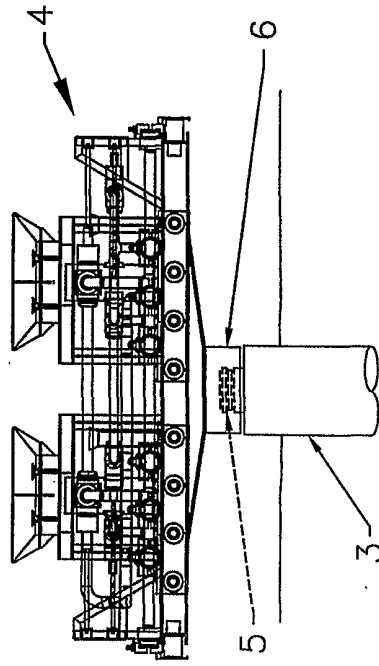

Fig. 8

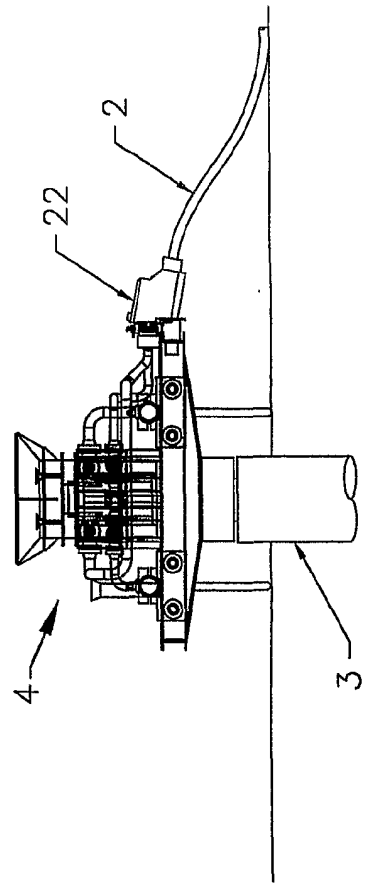

Fig. 9

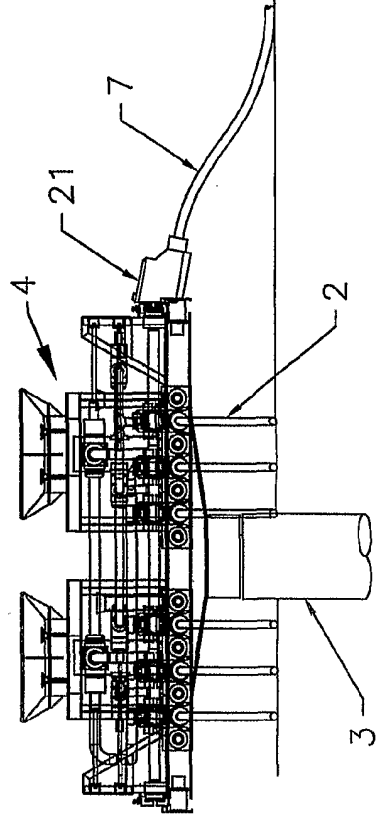

Fig. 10



Fig. 11

6/12

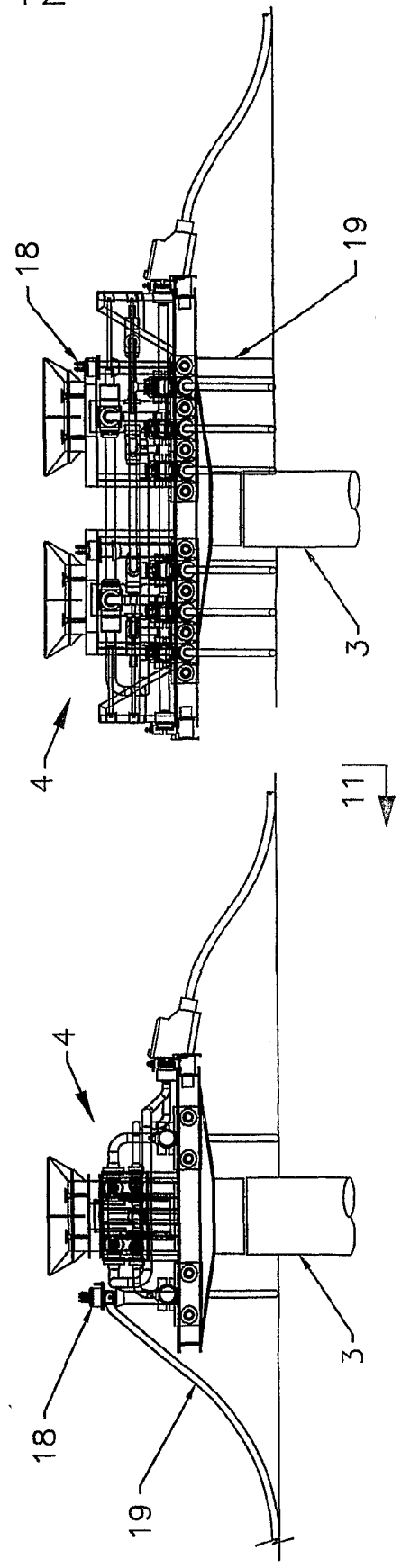

Fig. 13

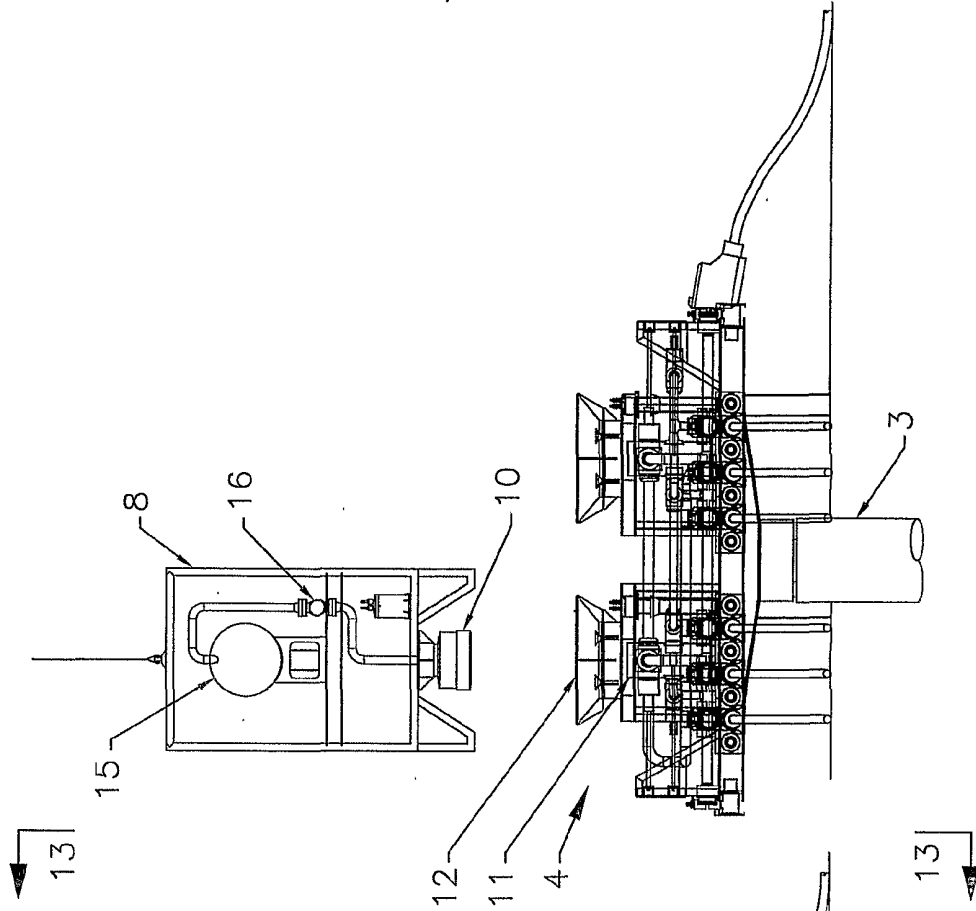
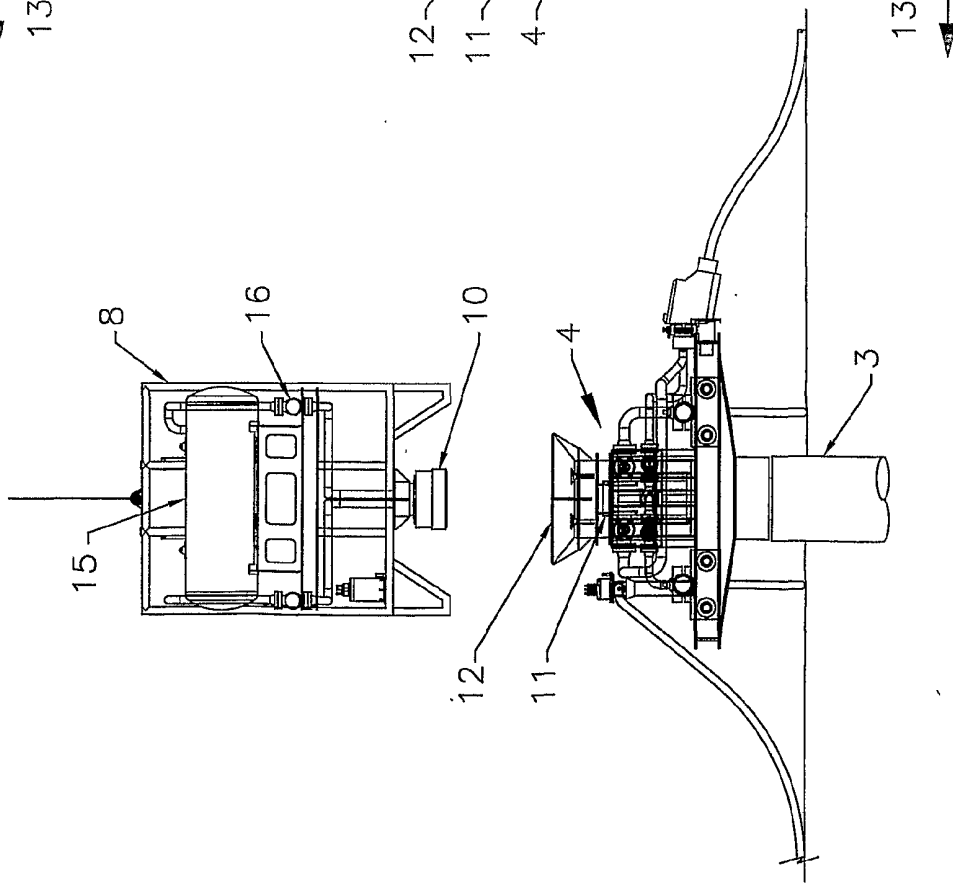

Fig. 12



8/12

Fig. 15

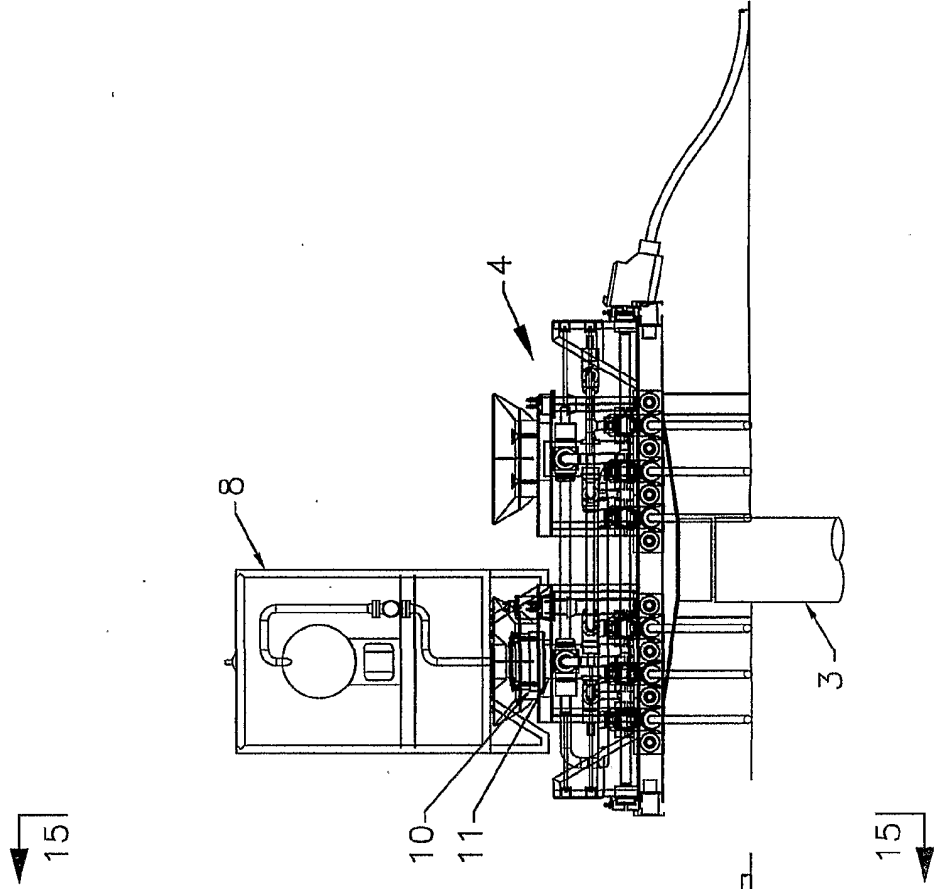

Fig. 14

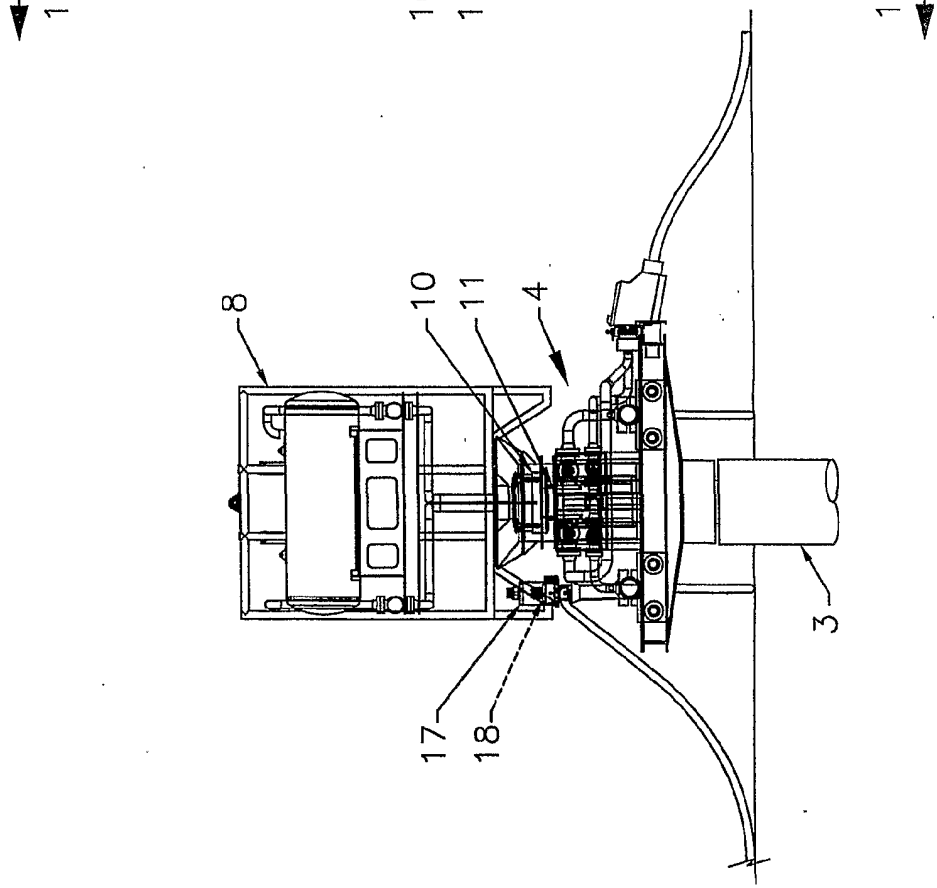

Fig. 17

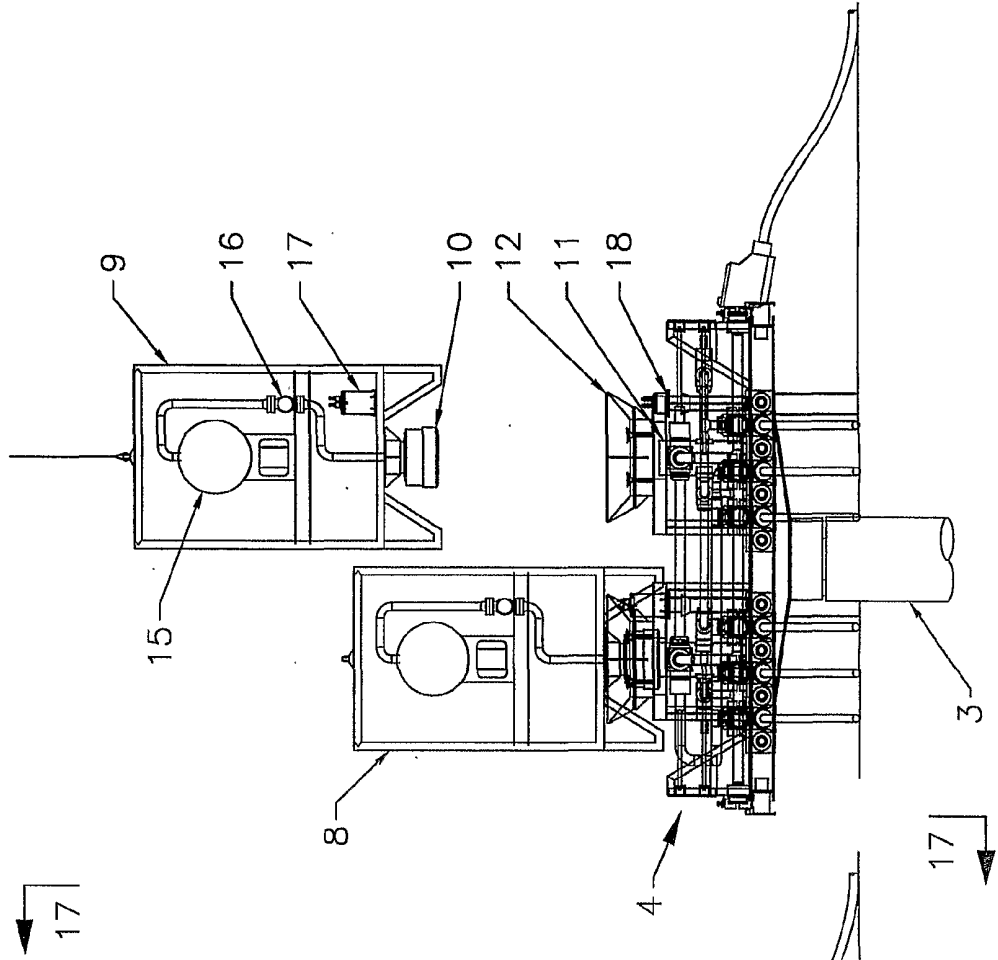

Fig. 16

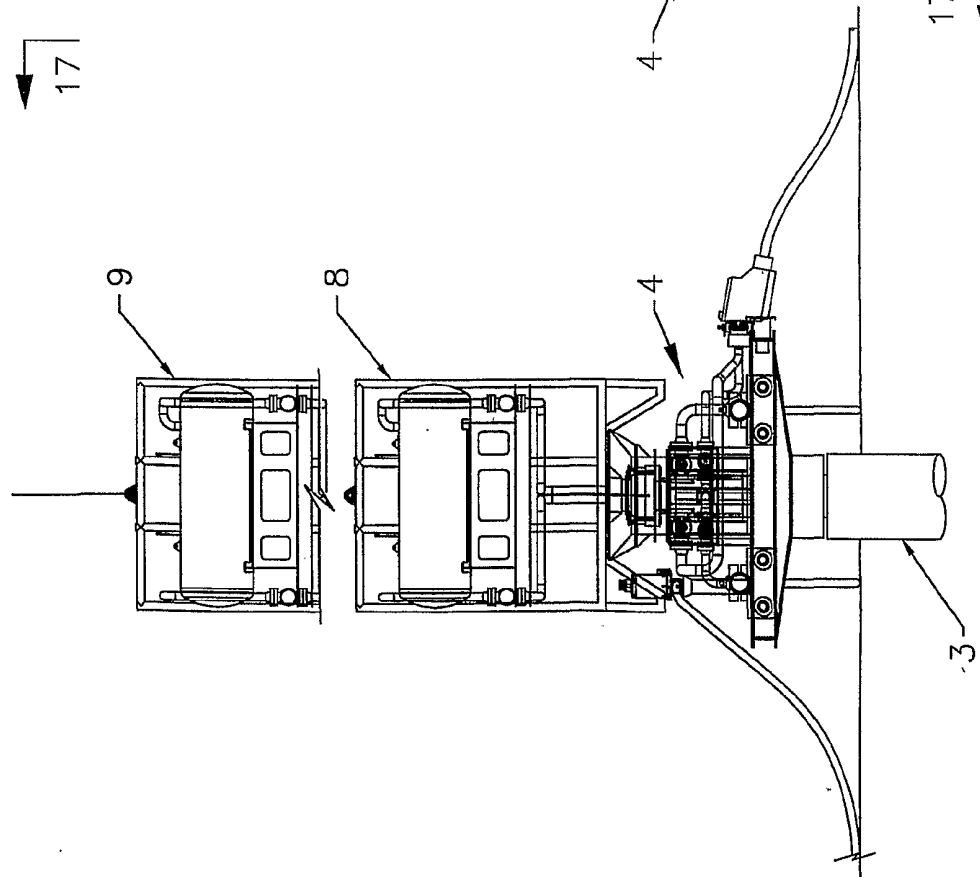

Fig. 18

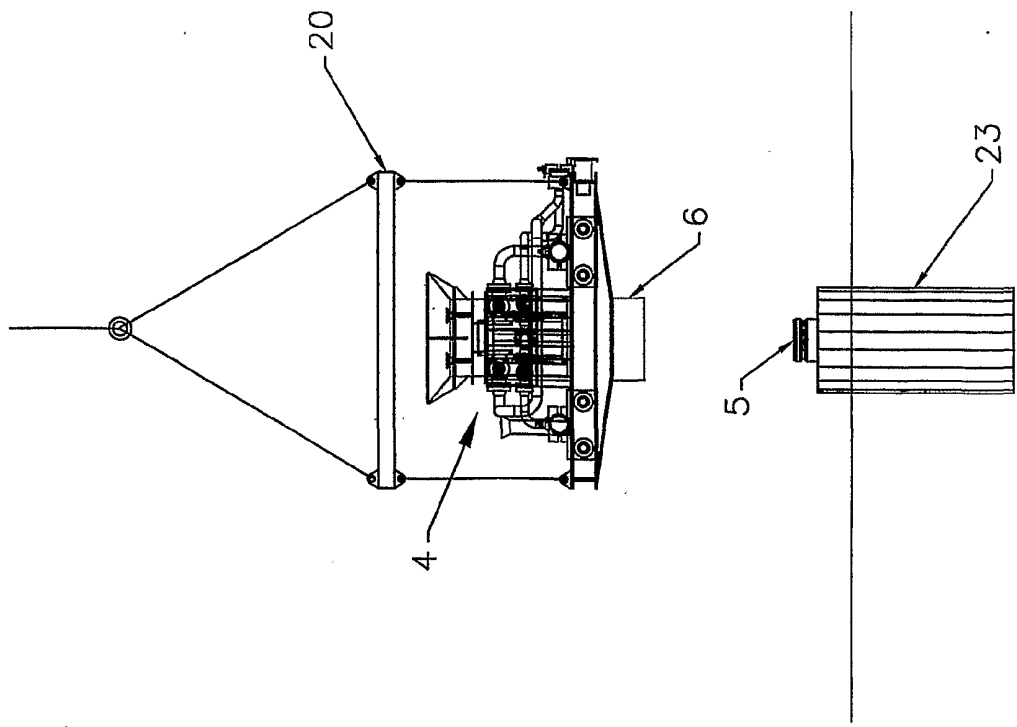

Fig. 19

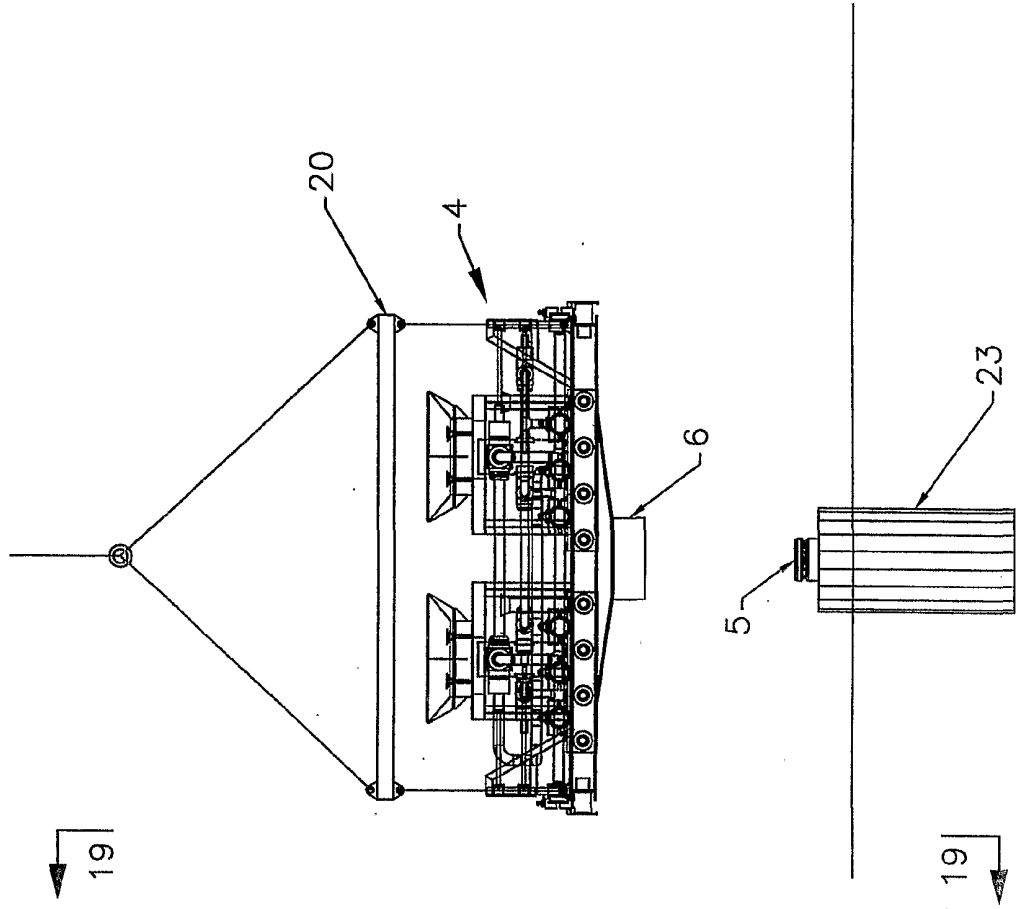

FIG. 21

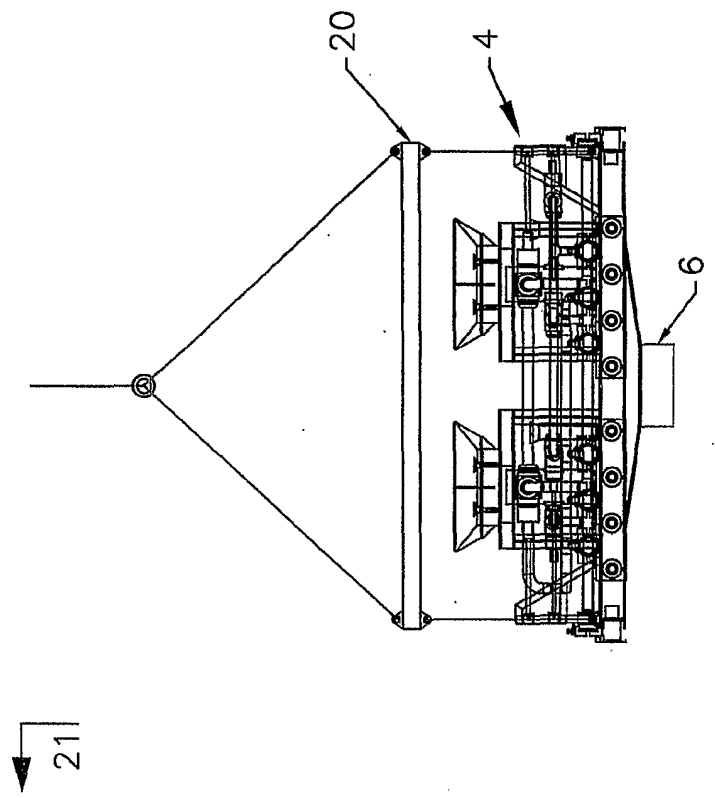

Fig. 20

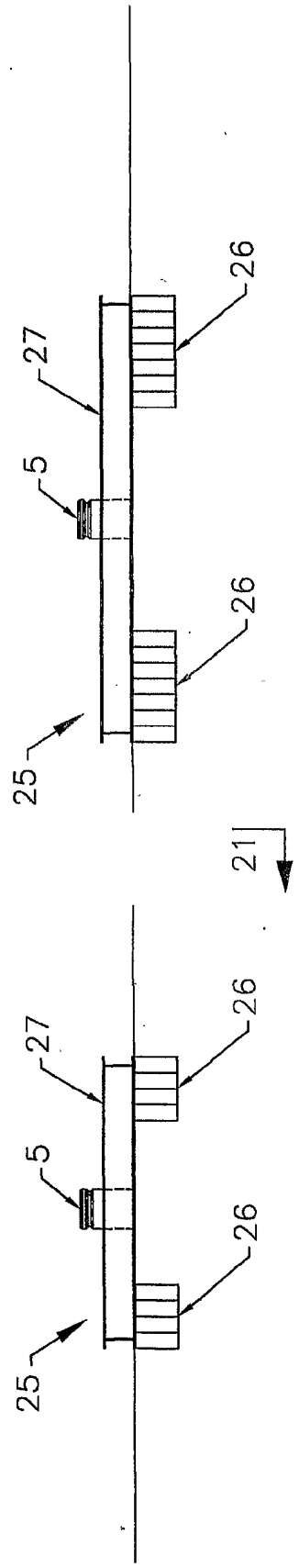
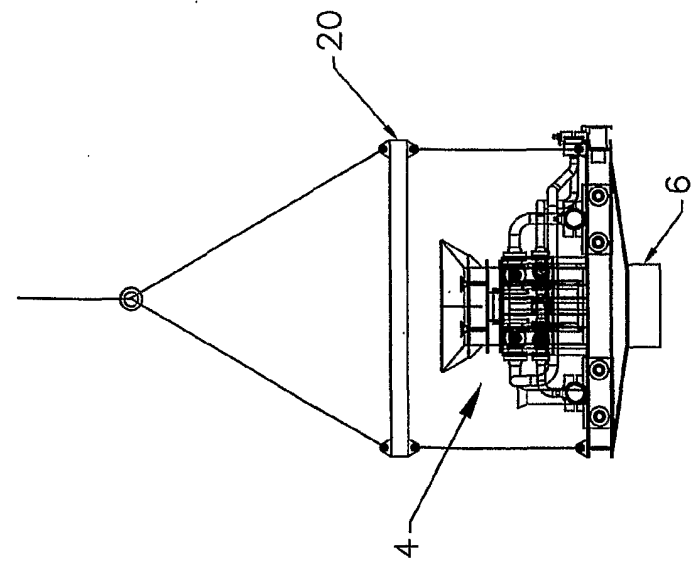

Fig. 23

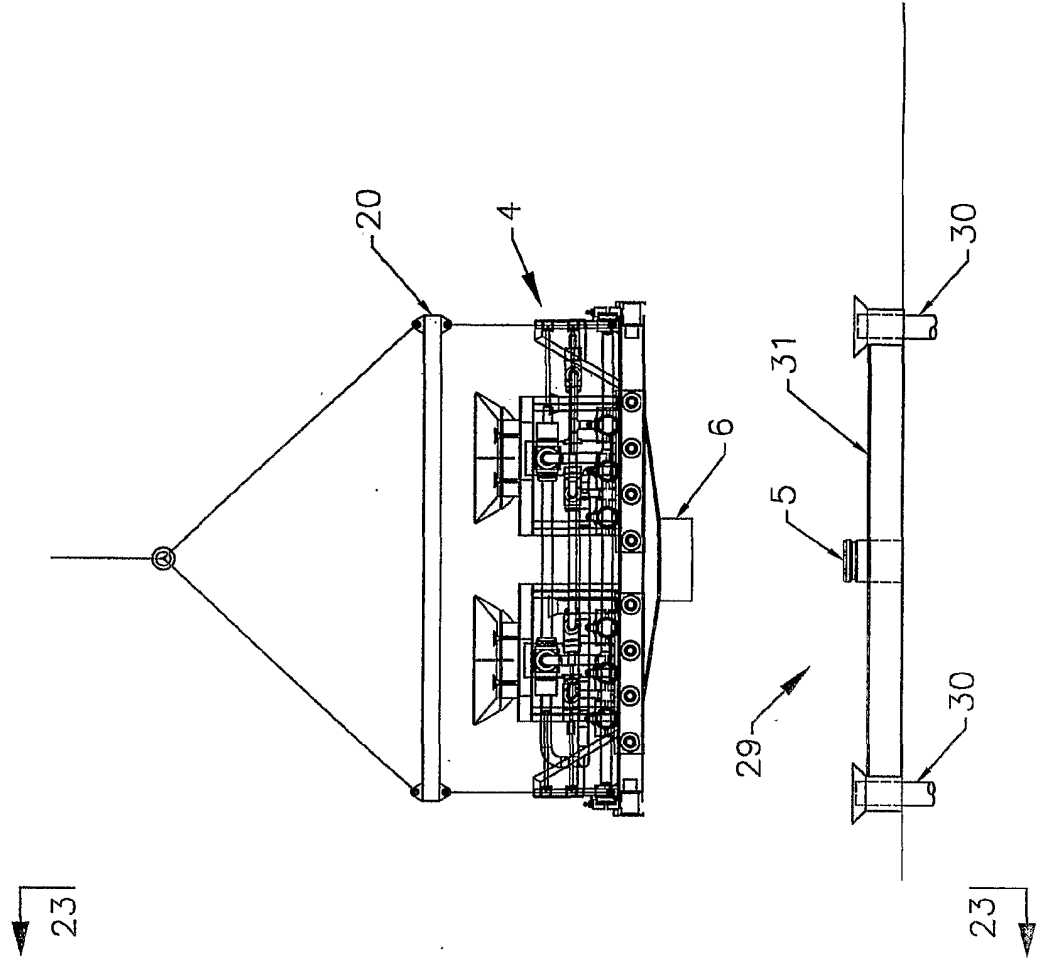
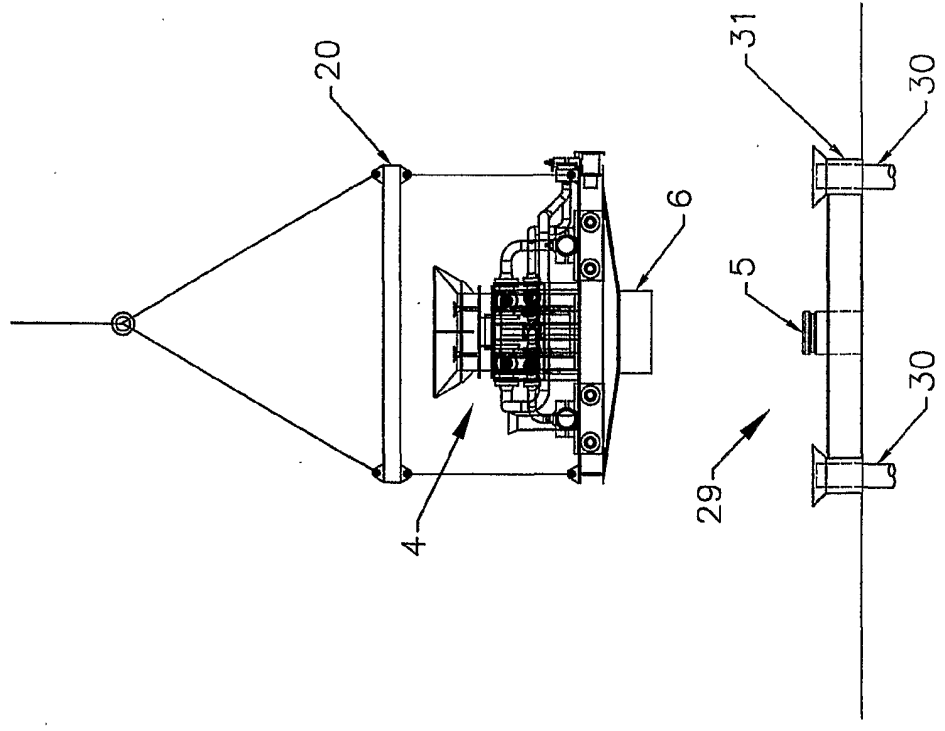

Fig. 22



INTERNATIONAL SEARCH REPORT

International Application No
 PCT/GB 01/03731

A. CLASSIFICATION OF SUBJECT MATTER
 IPC 7 E21B43/017 E21B43/013

According to International Patent Classification (IPC) or to both national classification and IPC

B. FIELDS SEARCHED

Minimum documentation searched (classification system followed by classification symbols)
 IPC 7 E21B

Documentation searched other than minimum documentation to the extent that such documents are included in the fields searched

Electronic data base consulted during the international search (name of data base and, where practical, search terms used)

EPO-Internal, WPI Data

C. DOCUMENTS CONSIDERED TO BE RELEVANT

Category °	Citation of document, with indication, where appropriate, of the relevant passages	Relevant to claim No.
X	GB 2 202 256 A (BRITISH PETROLEUM CO PLC) 21 September 1988 (1988-09-21) page 5, line 15 - line 34 page 7, line 5 - line 15 ---	1-3,6,7, 9-22, 24-28
X	US 4 427 072 A (LAWSON JOHN E) 24 January 1984 (1984-01-24) column 3, line 61 -column 4, line 17; figures 2,3 --- -/--	1,2,7,9, 10,12, 15-18, 22, 24-26,28

Further documents are listed in the continuation of box C. Patent family members are listed in annex.

° Special categories of cited documents :

A document defining the general state of the art which is not considered to be of particular relevance	*T* later document published after the international filing date or priority date and not in conflict with the application but cited to understand the principle or theory underlying the invention
E earlier document but published on or after the international filing date	*X* document of particular relevance; the claimed invention cannot be considered novel or cannot be considered to involve an inventive step when the document is taken alone
L document which may throw doubts on priority claim(s) or which is cited to establish the publication date of another citation or other special reason (as specified)	*Y* document of particular relevance; the claimed invention cannot be considered to involve an inventive step when the document is combined with one or more other such documents, such combination being obvious to a person skilled in the art.
O document referring to an oral disclosure, use, exhibition or other means	*&* document member of the same patent family
P document published prior to the international filing date but later than the priority date claimed	

Date of the actual completion of the international search 29 November 2001	Date of mailing of the international search report 06/12/2001
---	--

Name and mailing address of the ISA European Patent Office, P.B. 5818 Patentlaan 2 NL - 2280 HV Rijswijk Tel. (+31-70) 340-2040, Tx. 31 651 epo nl, Fax: (+31-70) 340-3016	Authorized officer Garrido Garcia, M
--	---

INTERNATIONAL SEARCH REPORT

International Application No
PCT/GB 01/03731

C.(Continuation) DOCUMENTS CONSIDERED TO BE RELEVANT		
Category	Citation of document, with indication, where appropriate, of the relevant passages	Relevant to claim No.
X	<p>WO 00 47864 A (GATHERAR NICHOLAS ;KENT RICHARD (GB); ANDERSEN TORE (NO); HATLO AN) 17 August 2000 (2000-08-17)</p> <p>page 18, line 30 -page 19, line 3 page 24, line 21 -page 27, line 17</p> <p>----</p>	<p>1,3,4,6, 7,11-17, 19-21, 25-28</p>
A	<p>GB 2 261 271 A (ALPHA THAMES ENG) 12 May 1993 (1993-05-12)</p> <p>page 12, line 19 -page 13, line 9 page 15, line 16 - line 23</p> <p>----</p>	<p>1-28</p>
A	<p>US 5 040 607 A (CORDEIRO ANDRE L ET AL) 20 August 1991 (1991-08-20)</p> <p>claim 1; figure 6</p> <p>----</p>	<p>1-28</p>
A	<p>US 4 194 857 A (CHATEAU GEORGES M ET AL) 25 March 1980 (1980-03-25)</p> <p>column 3, line 41 - line 64</p> <p>-----</p>	<p>1-28</p>

INTERNATIONAL SEARCH REPORT

Information on patent family members

In International Application No

PCT/GB 01/03731

Patent document cited in search report		Publication date	Patent family member(s)	Publication date
GB 2202256	A	21-09-1988	NONE	
US 4427072	A	24-01-1984	GB 2121454 A	21-12-1983
WO 0047864	A	17-08-2000	AU 2453300 A EP 1151178 A1 WO 0047864 A1 GB 2346630 A , B	29-08-2000 07-11-2001 17-08-2000 16-08-2000
GB 2261271	A	12-05-1993	BR 9206734 A EP 0611411 A1 WO 9310327 A1 NO 941737 A US 5494110 A	21-11-1995 24-08-1994 27-05-1993 10-05-1994 27-02-1996
US 5040607	A	20-08-1991	BR 8806661 A AU 605435 B2 AU 4109089 A CA 1333280 A1 FI 892252 A , B, FR 2640681 A1 GB 2226063 A , B IT 1237055 B MX 171929 B NL 8902401 A , B, NO 179981 B	31-07-1990 10-01-1991 21-06-1990 29-11-1994 17-06-1990 22-06-1990 20-06-1990 13-05-1993 24-11-1993 16-07-1990 14-10-1996
US 4194857	A	25-03-1980	US 4120362 A AU 507427 B2 AU 3065677 A BE 861005 A1 BR 7707725 A CA 1070966 A1 DE 2752024 A1 DK 515277 A EG 13291 A ES 464363 A1 FR 2371552 A1 GB 1576897 A IE 45911 B1 IN 147928 A1 IT 1088647 B JP 1062130 C JP 53065202 A JP 56002872 B NL 7712874 A NO 773978 A , B, OA 5808 A SE 7713127 A ZA 7706936 A	17-10-1978 14-02-1980 24-05-1979 16-03-1978 05-06-1979 05-02-1980 01-06-1978 23-05-1978 30-06-1981 01-08-1978 16-06-1978 15-10-1980 29-12-1982 16-08-1980 10-06-1985 31-08-1981 10-06-1978 22-01-1981 24-05-1978 23-05-1978 31-05-1981 23-05-1978 27-09-1978