



(19) **United States**

(12) **Patent Application Publication**
Garrett et al.

(10) **Pub. No.: US 2011/0105350 A1**

(43) **Pub. Date: May 5, 2011**

(54) **DIAGNOSIS OF SEPSIS**

Publication Classification

(75) Inventors: **James A. Garrett**, Baltimore, MD (US); **Sha-Sha Wang**, Cockeysville, MD (US); **Keith Thornton**, Owing Mills, MD (US); **Richard L. Moore**, Glenville, PA (US); **William Keating**, Reisterstown, MD (US); **William A. Nussbaumer**, Lutherville, MD (US); **Craig C. Whiteford**, York, PA (US)

(51) **Int. Cl.**
C40B 30/04 (2006.01)
C12Q 1/68 (2006.01)

(52) **U.S. Cl.** **506/9; 435/6**

(73) Assignee: **Becton, Dickinson and Company**

(21) Appl. No.: **12/776,245**

(22) Filed: **May 7, 2010**

(57) **ABSTRACT**

Methods for predicting the development of sepsis in a subject at risk for developing sepsis are provided. In one method, features in a biomarker profile of the subject are evaluated. The subject is likely to develop sepsis if these features satisfy a particular value set. Methods for predicting the development of a stage of sepsis in a subject at risk for developing a stage of sepsis are provided. In one method, a plurality of features in a biomarker profile of the subject is evaluated. The subject is likely to have the stage of sepsis if these feature values satisfy a particular value set. Methods of diagnosing sepsis in a subject are provided. In one such method, a plurality of features in a biomarker profile of the subject is evaluated. The subject is likely to develop sepsis when the plurality of features satisfies a particular value set.

Related U.S. Application Data

(63) Continuation of application No. 11/404,744, filed on Apr. 14, 2006, now Pat. No. 7,767,395.

(60) Provisional application No. 60/671,620, filed on Apr. 15, 2005, provisional application No. 60/674,046, filed on Apr. 22, 2005.

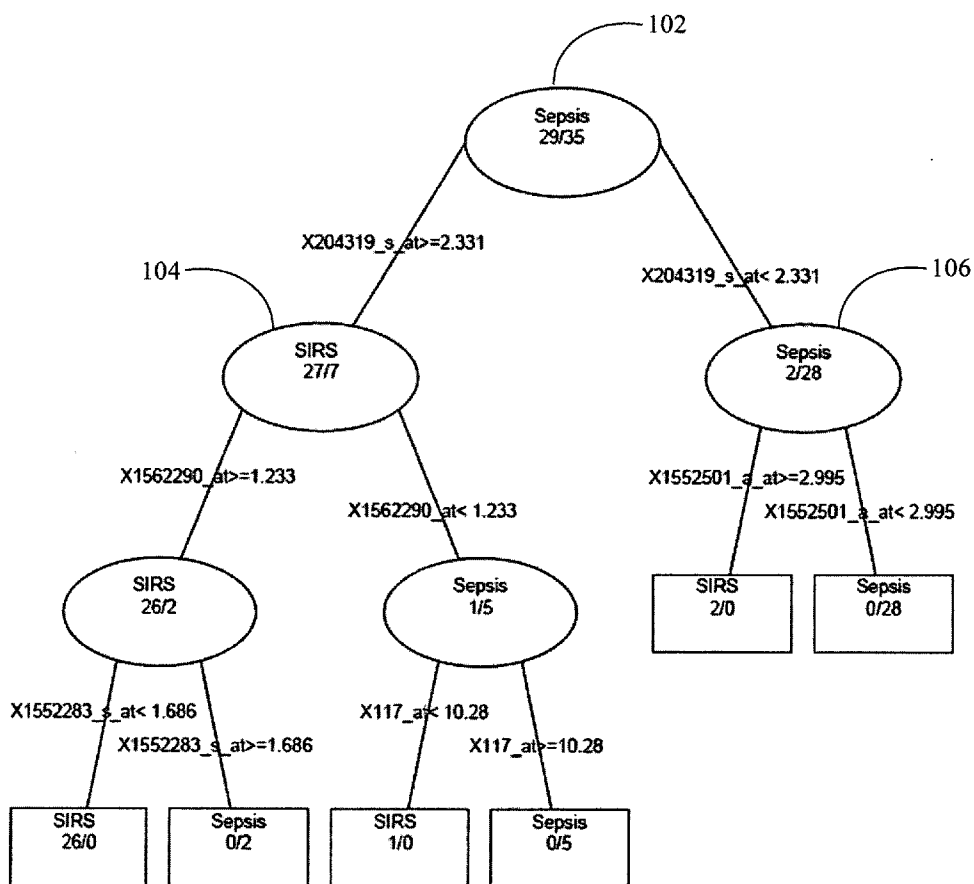

FIG.1

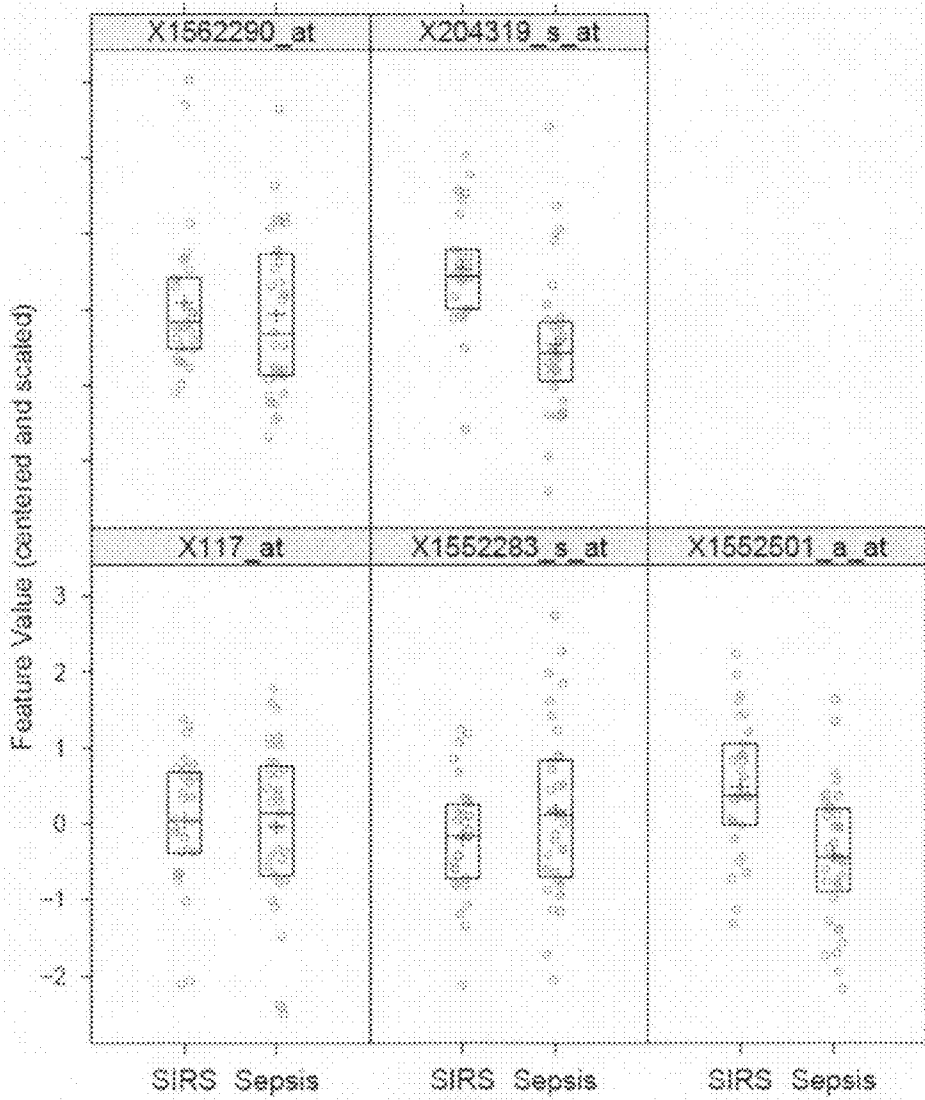

FIG. 2

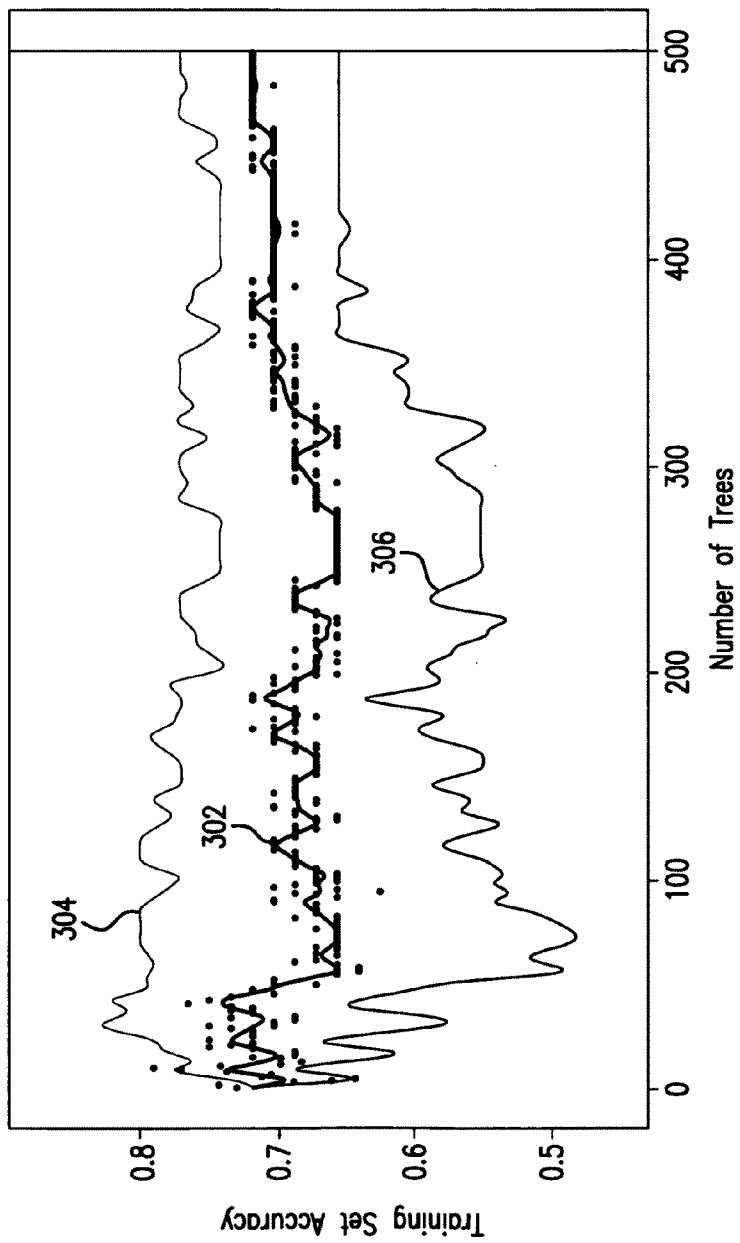

FIG.3

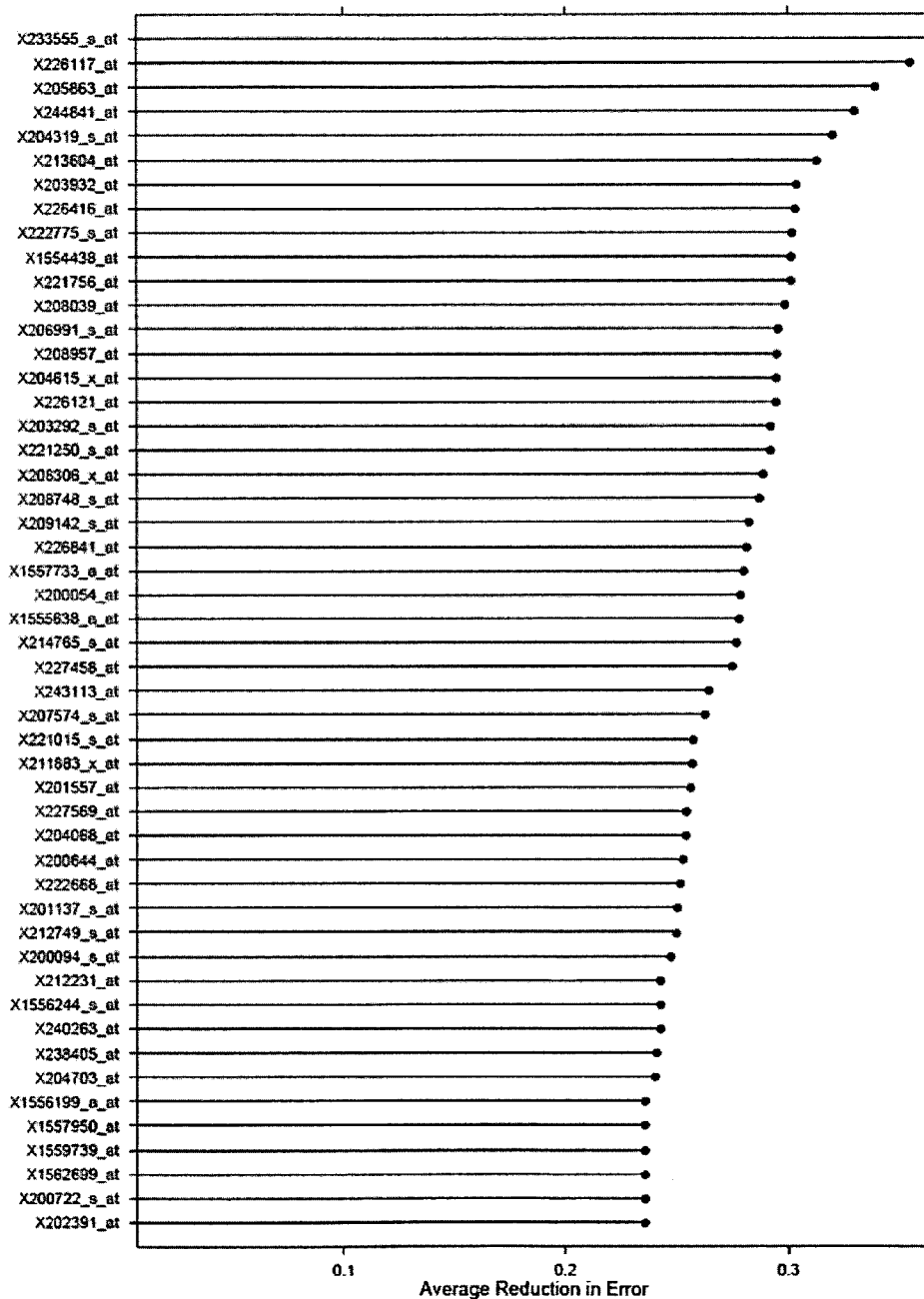
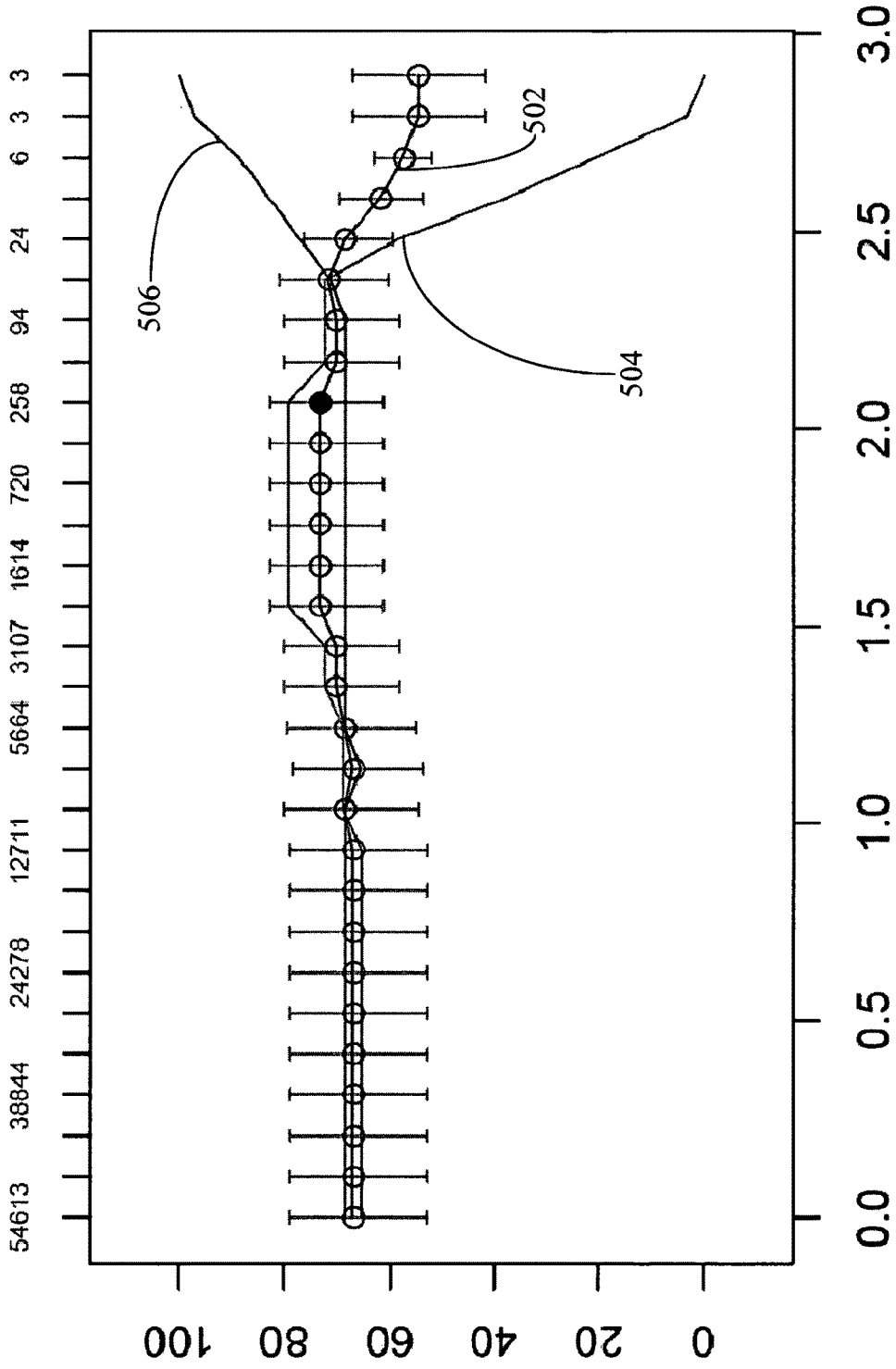

FIG.4



Threshold
FIG.5

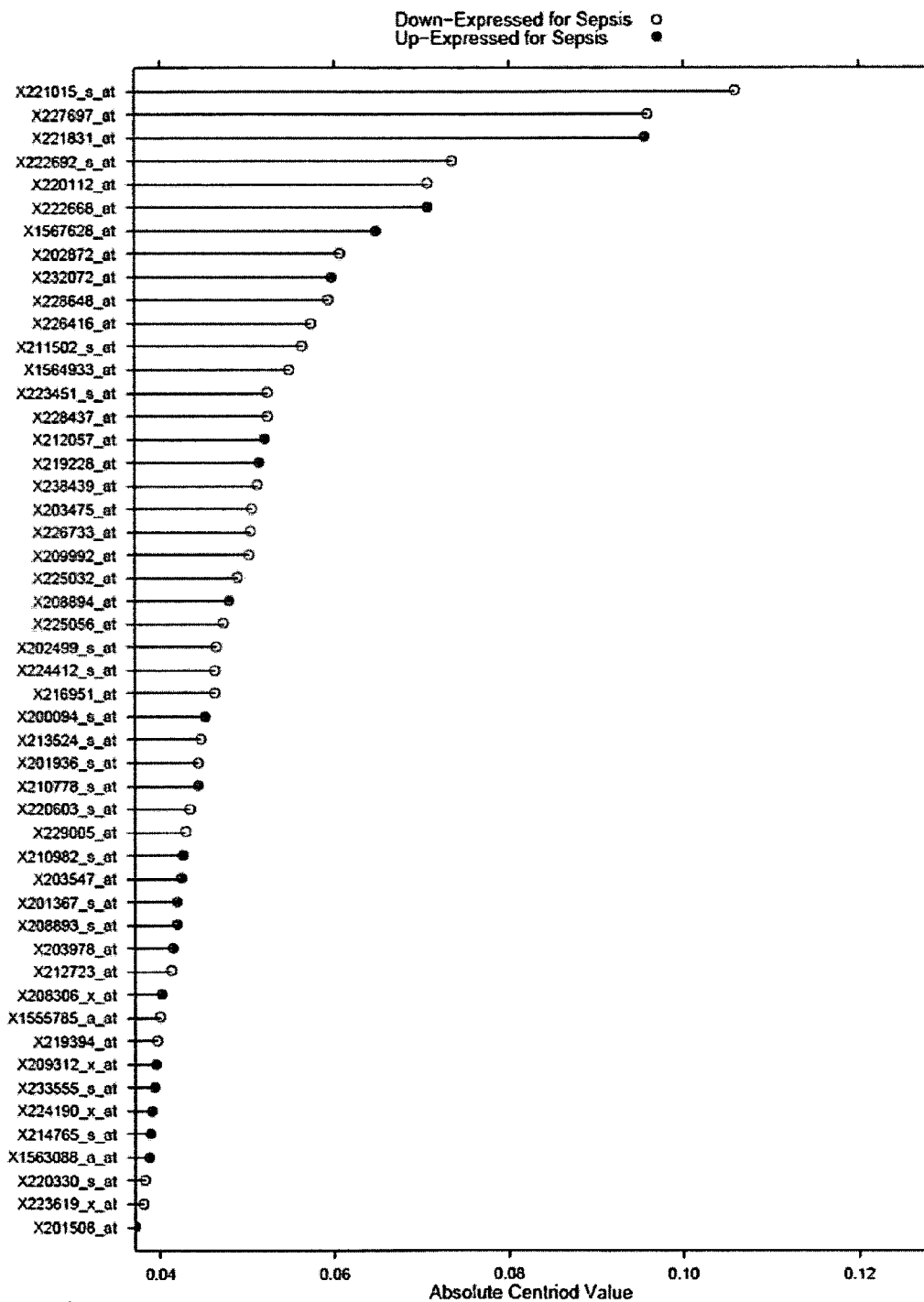

FIG.6

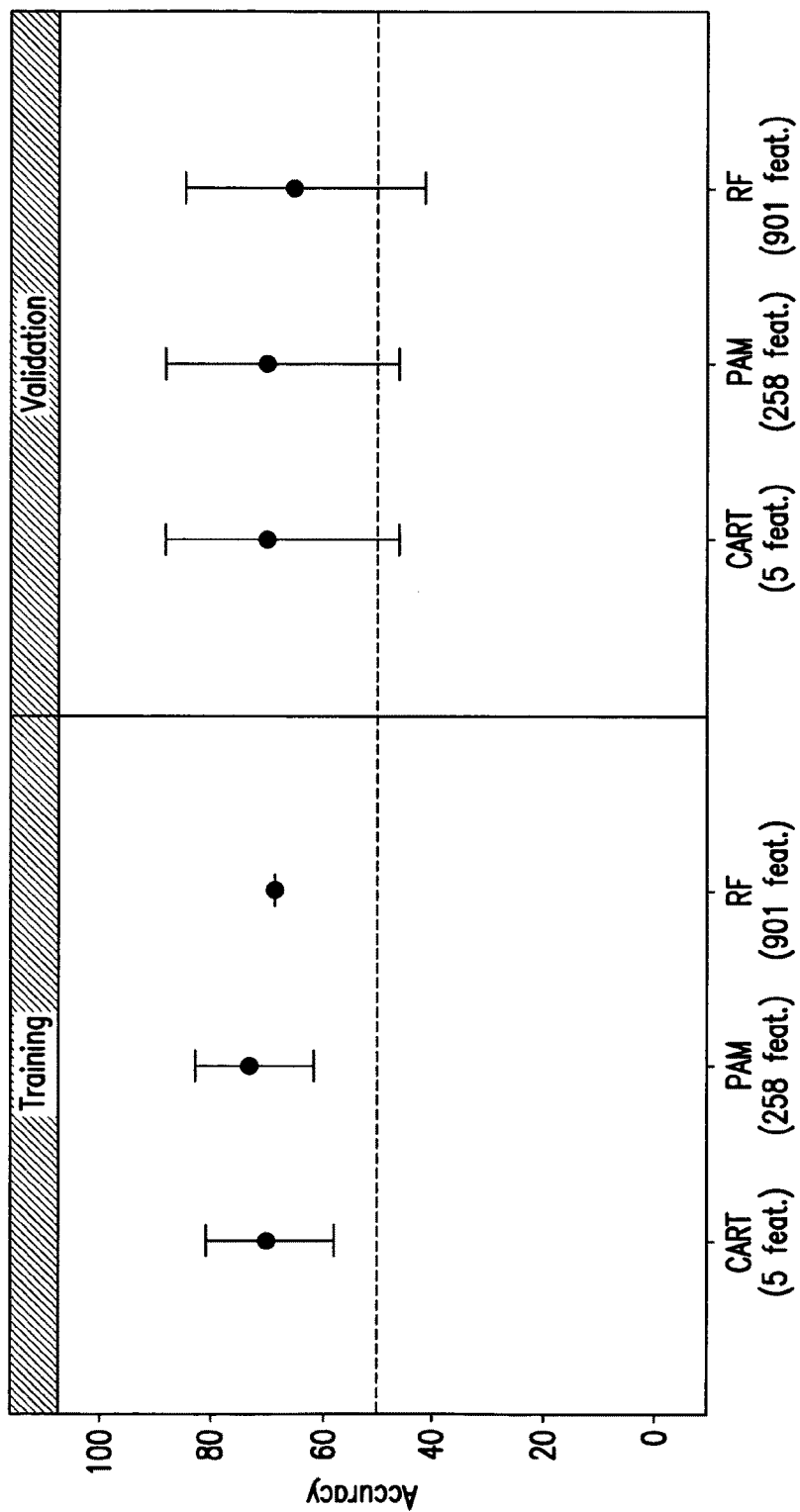

FIG. 7

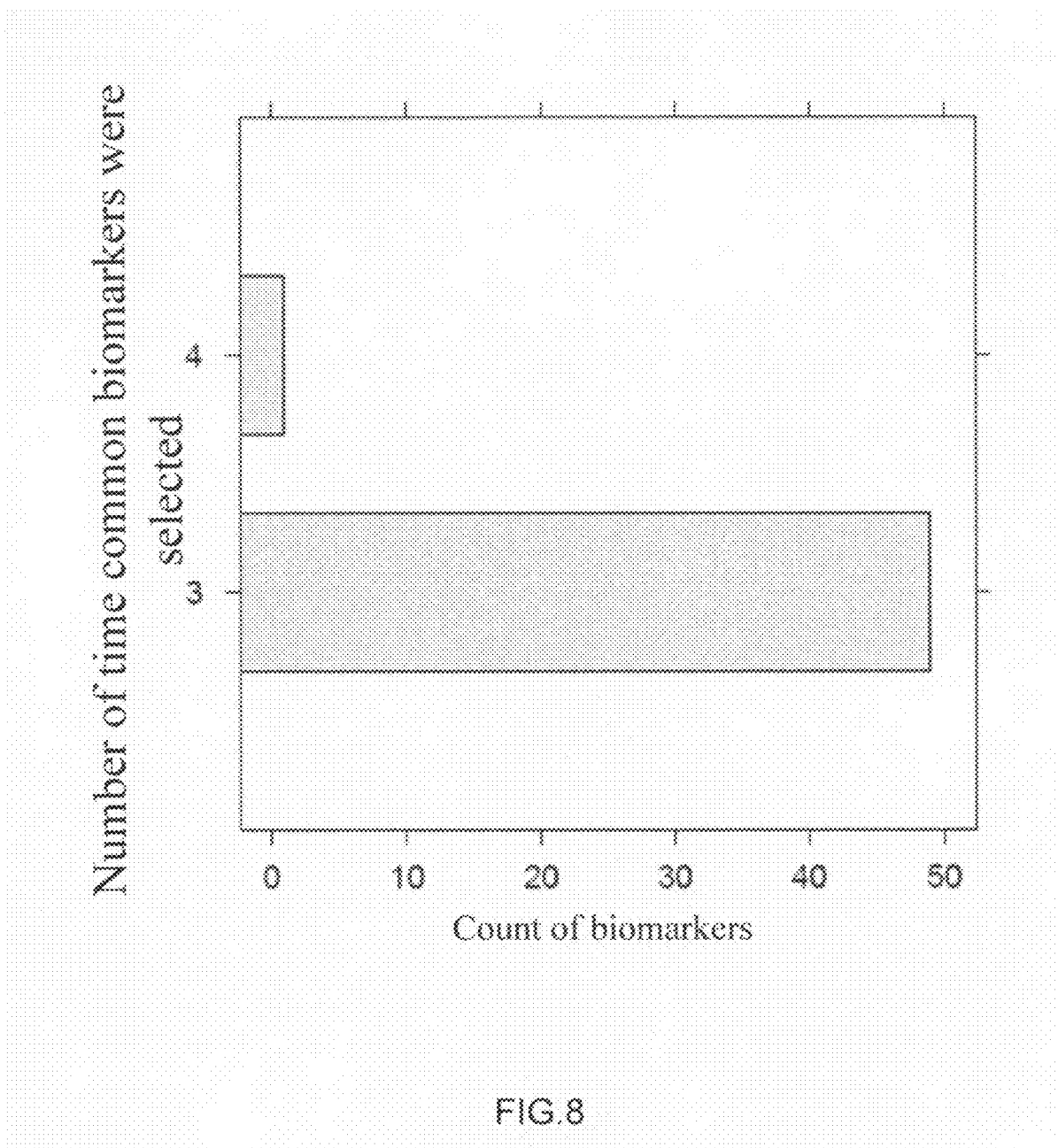

FIG. 8



Percent of time each biomarker was selected

FIG.9

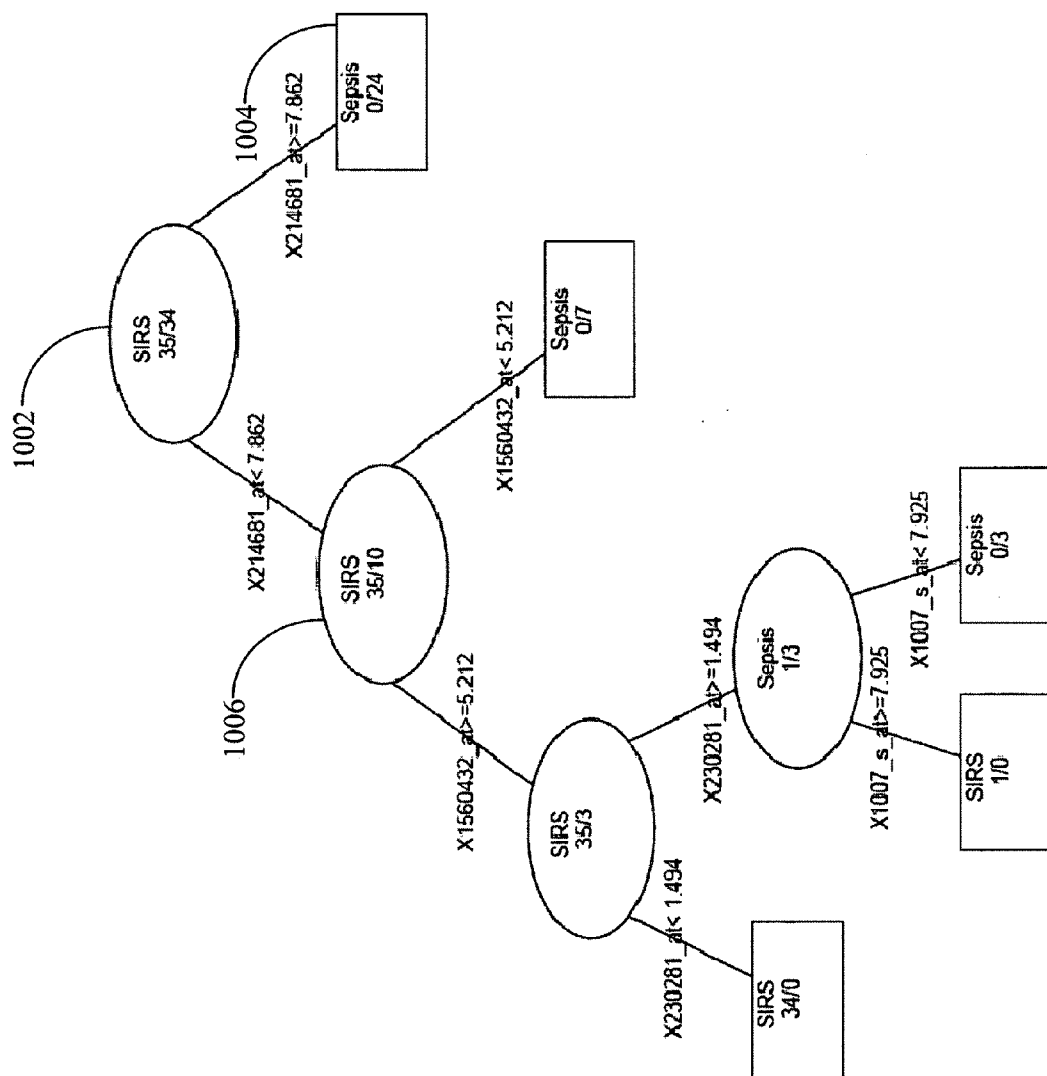

FIG.10

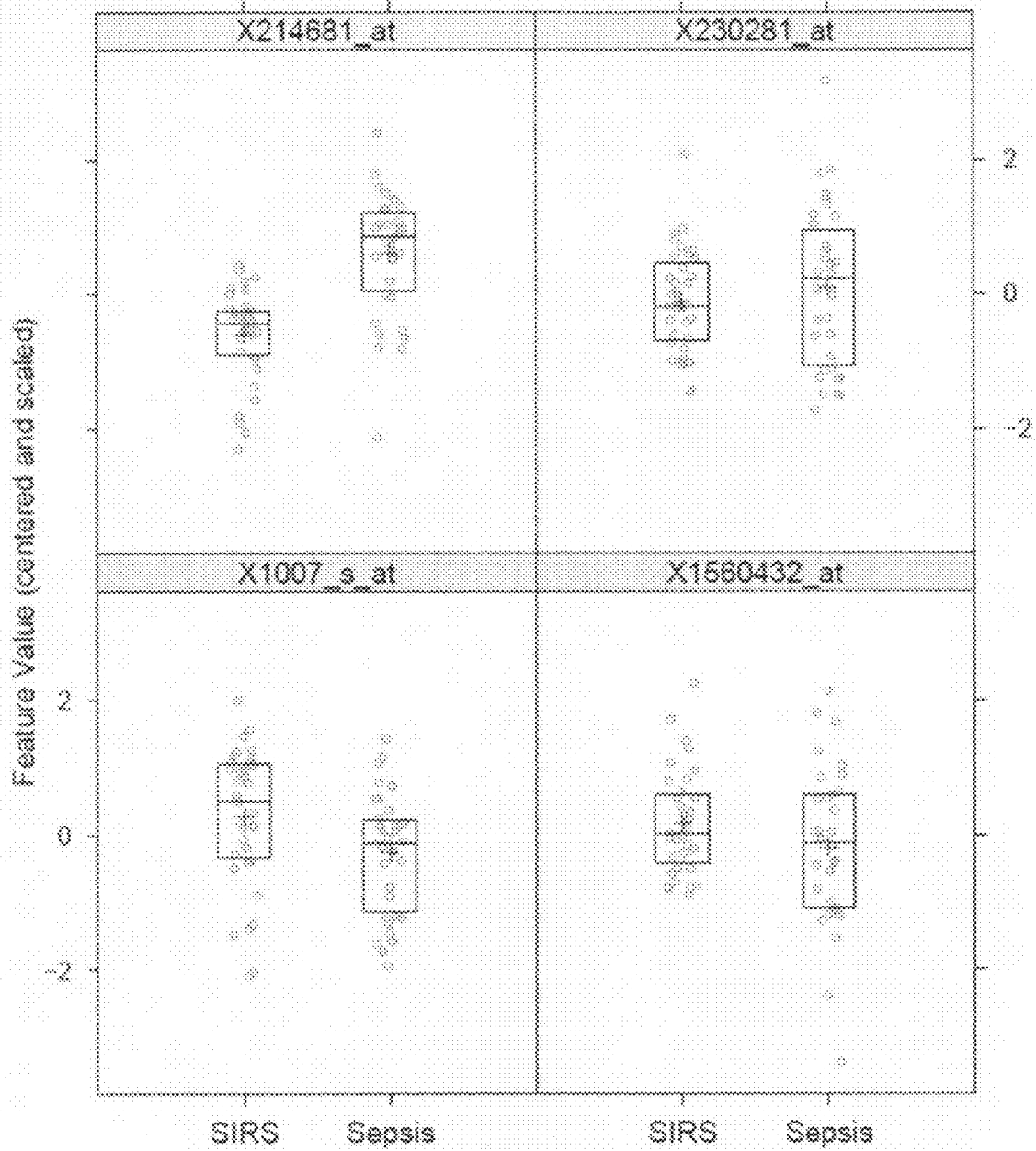

FIG.11

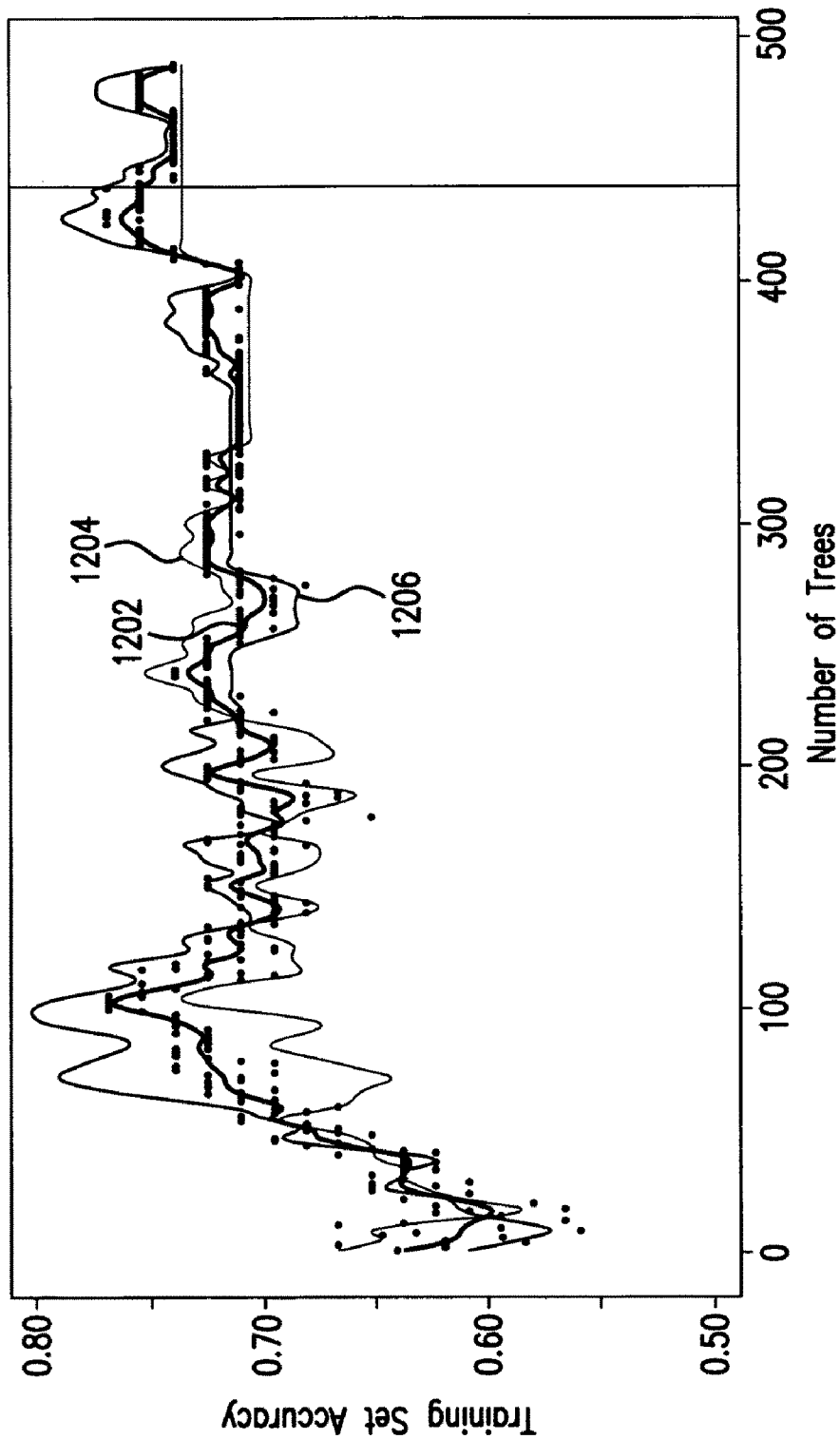

FIG.12

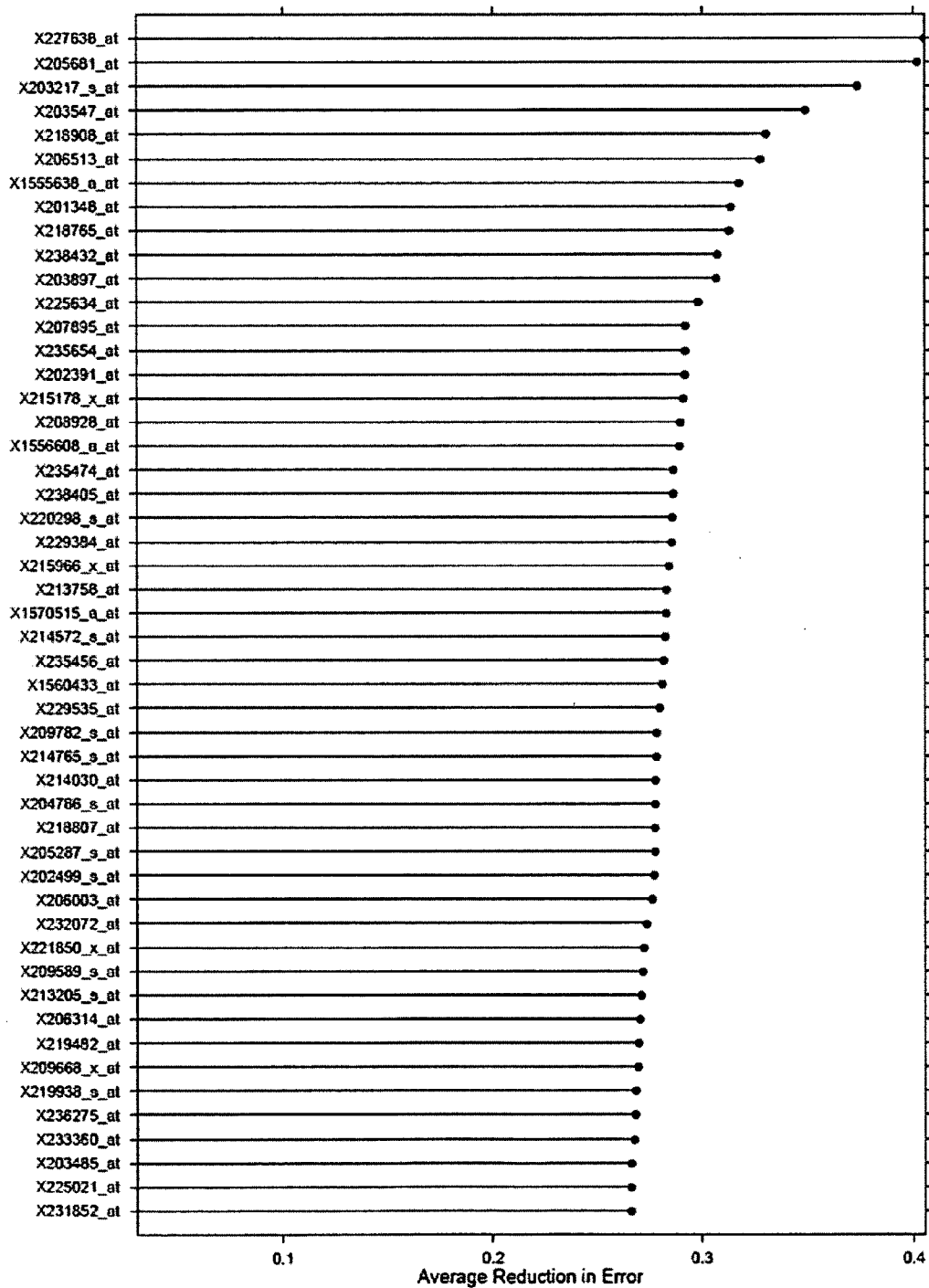

FIG.13

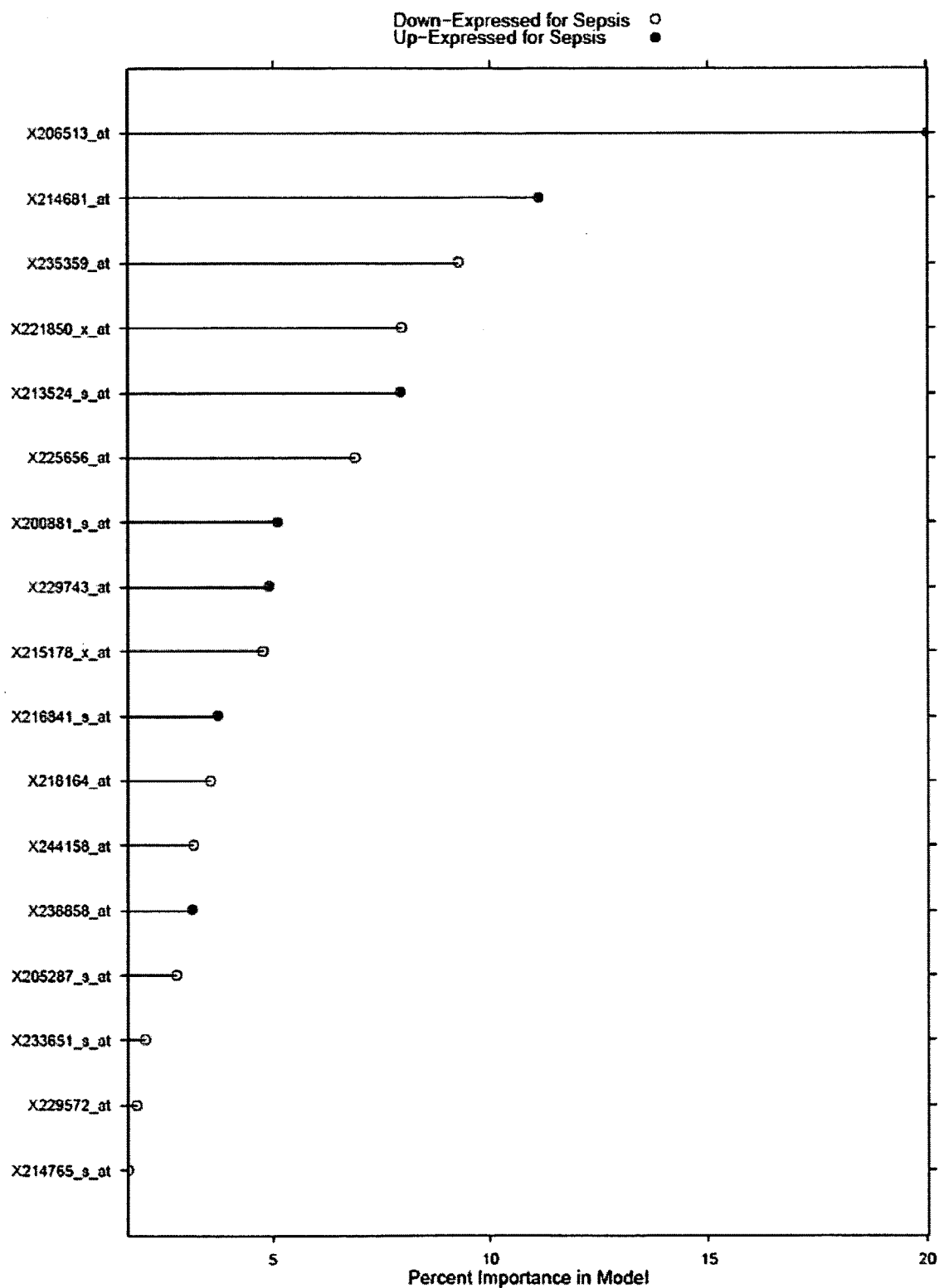

FIG.14

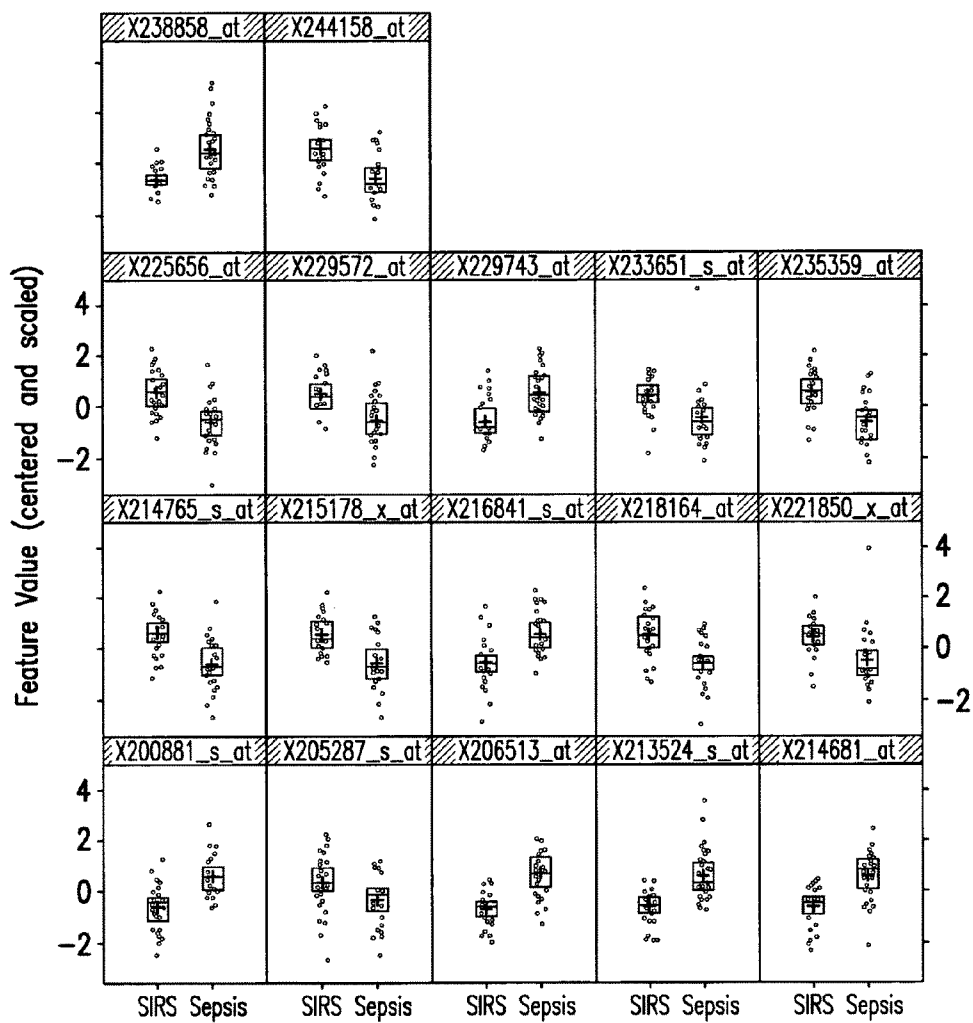
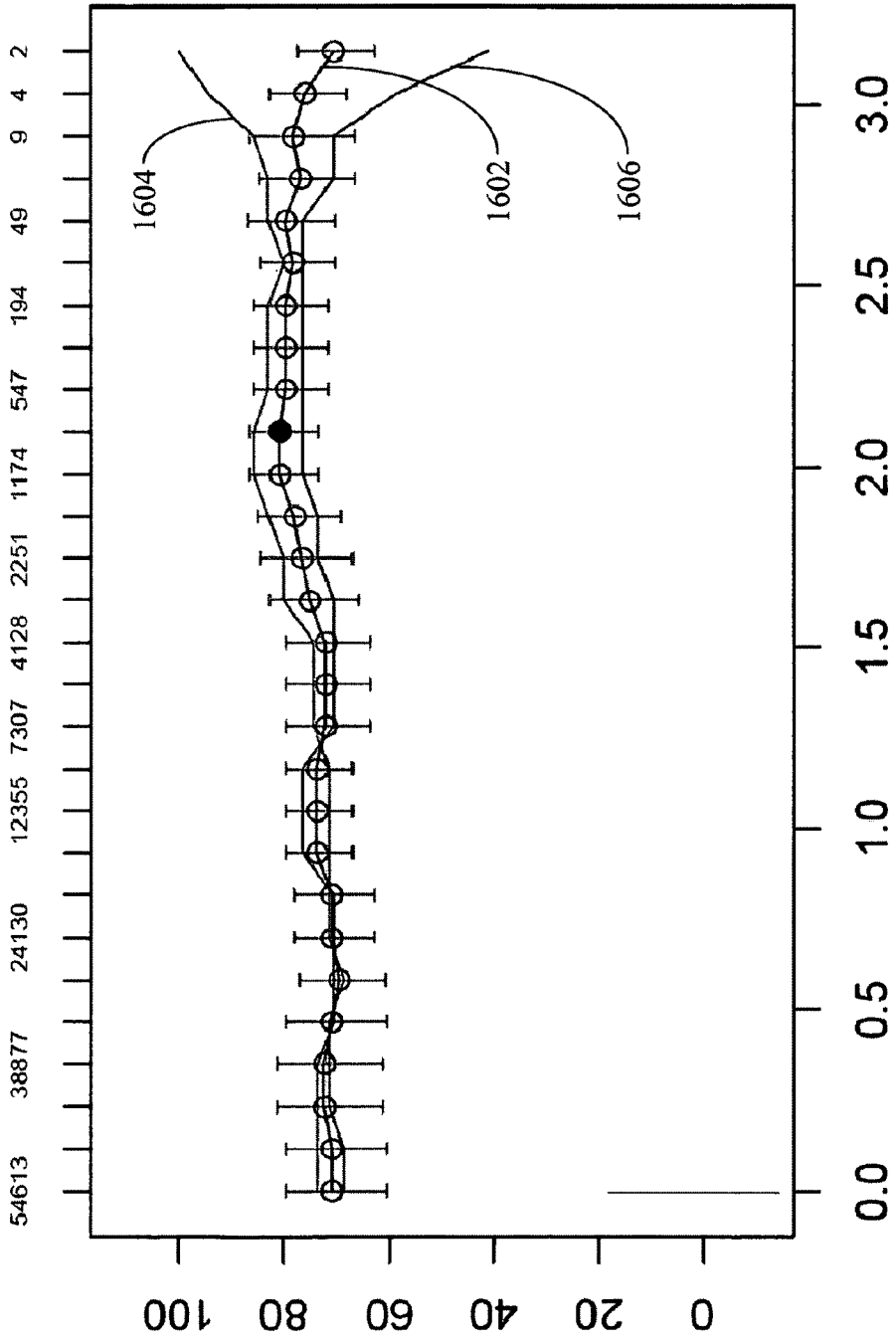

FIG. 15



Threshold
FIG.16

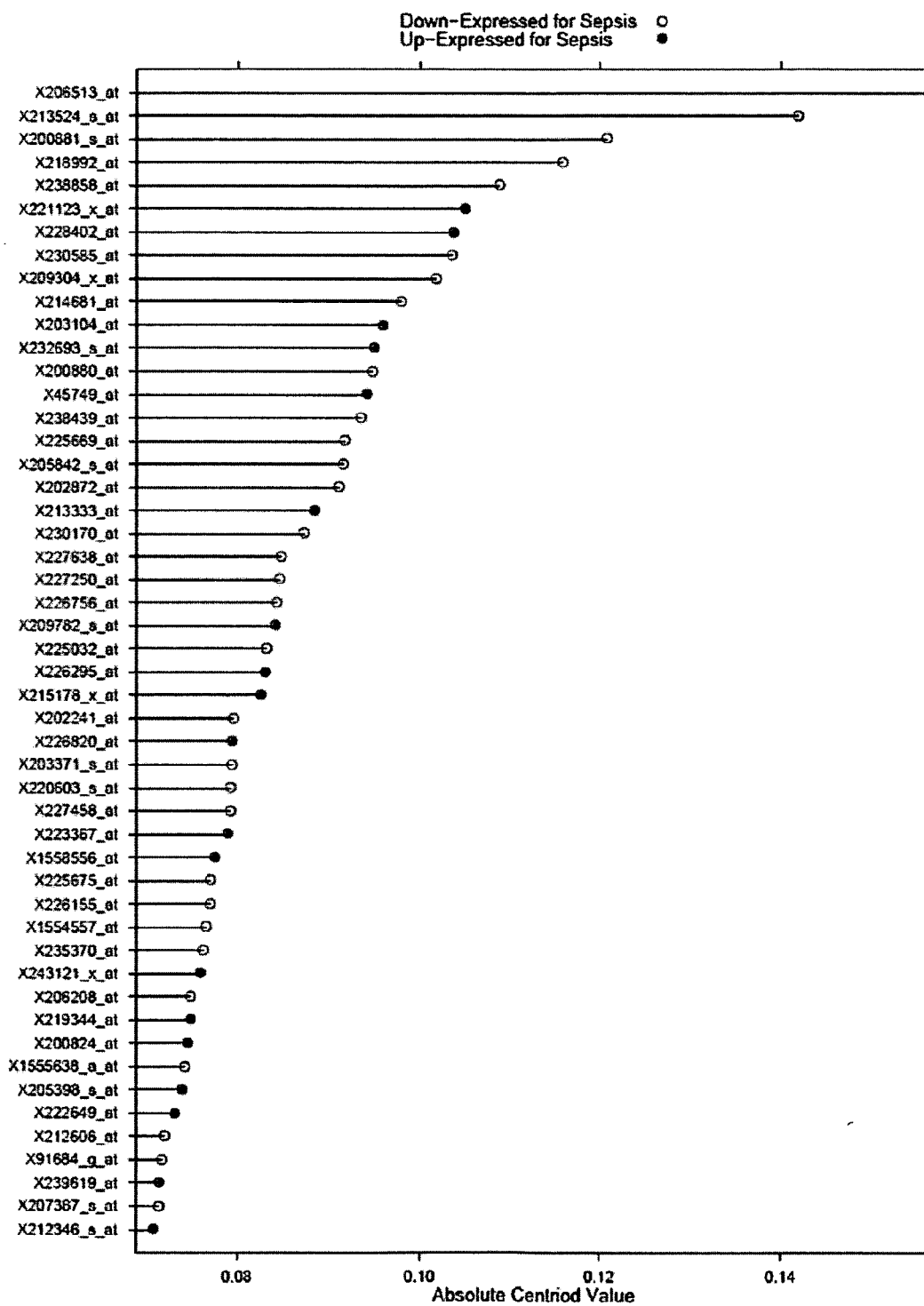

FIG.17

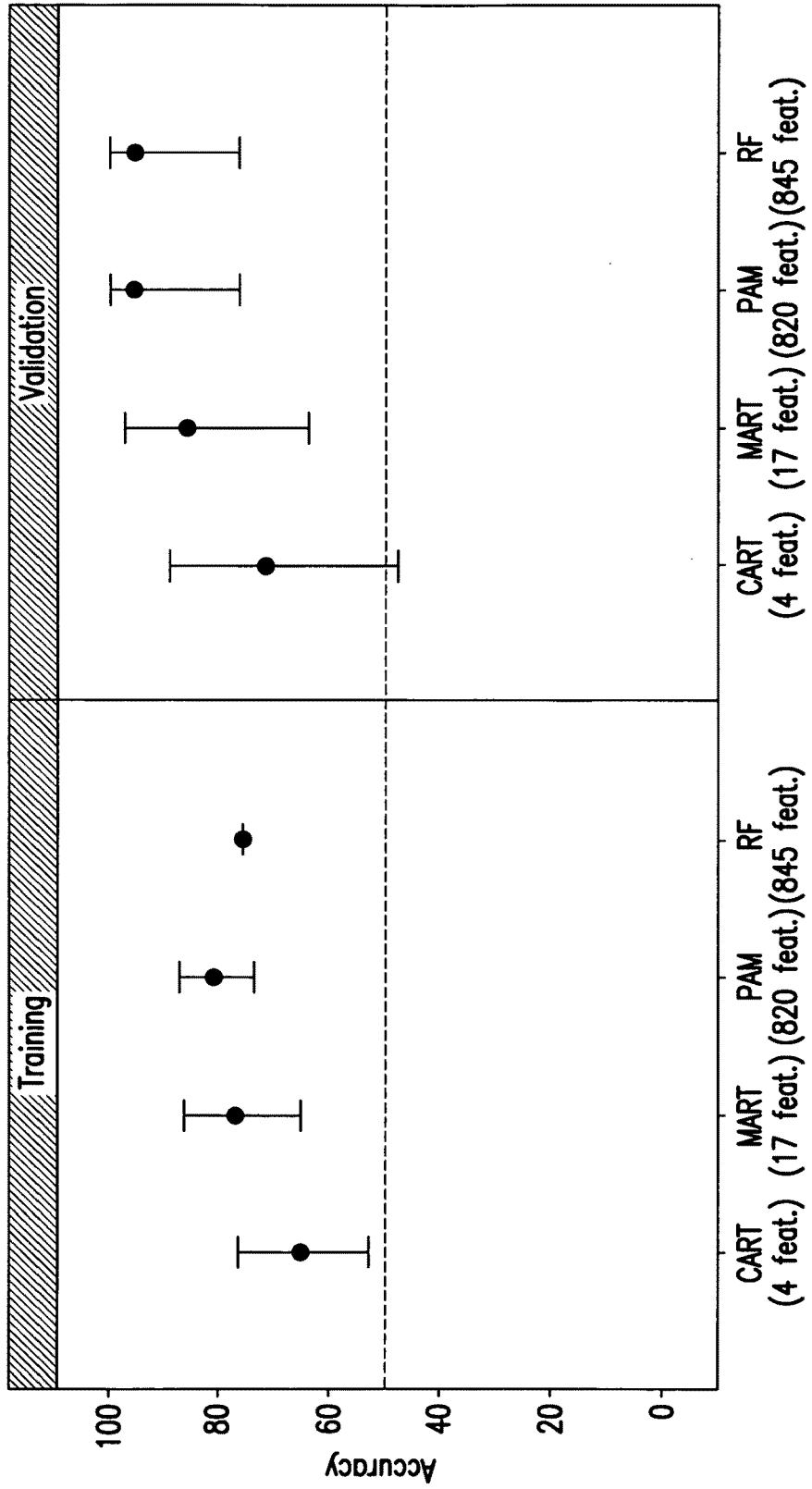

FIG. 18

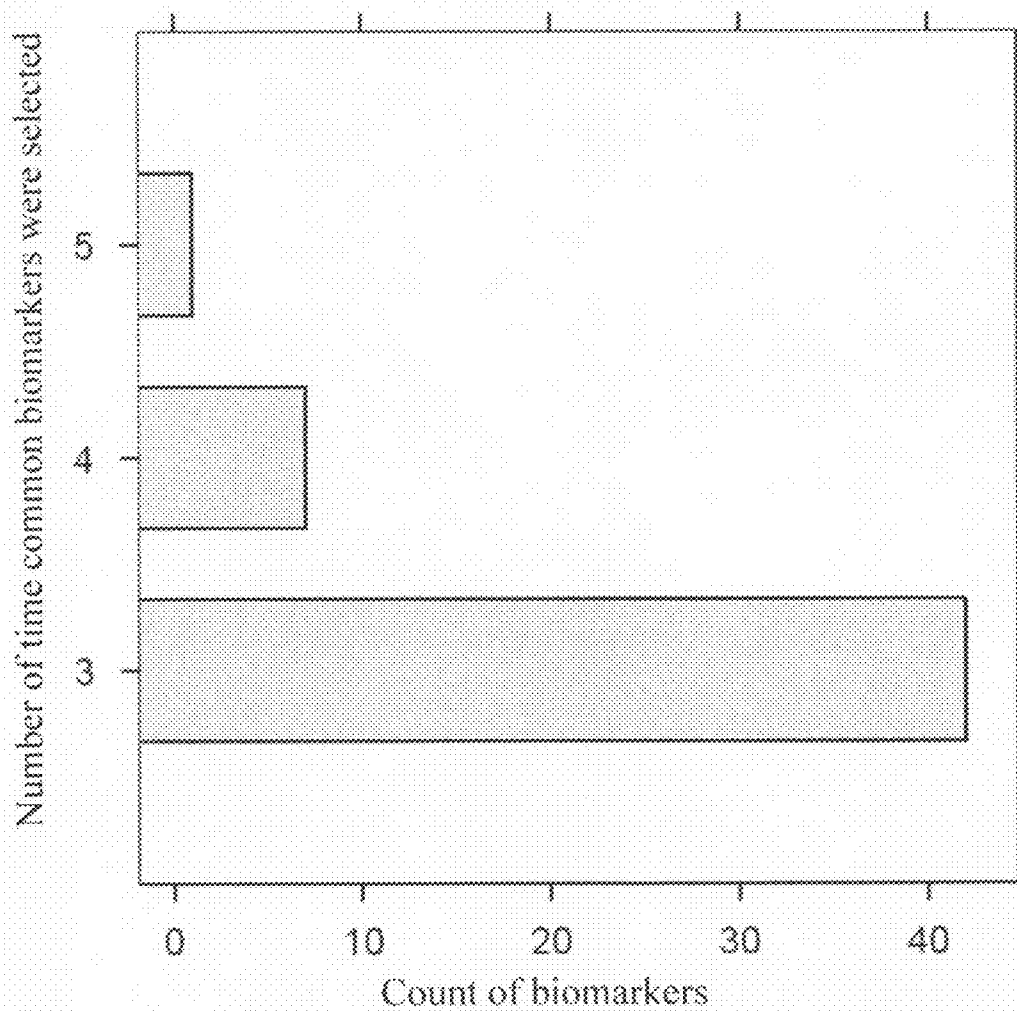
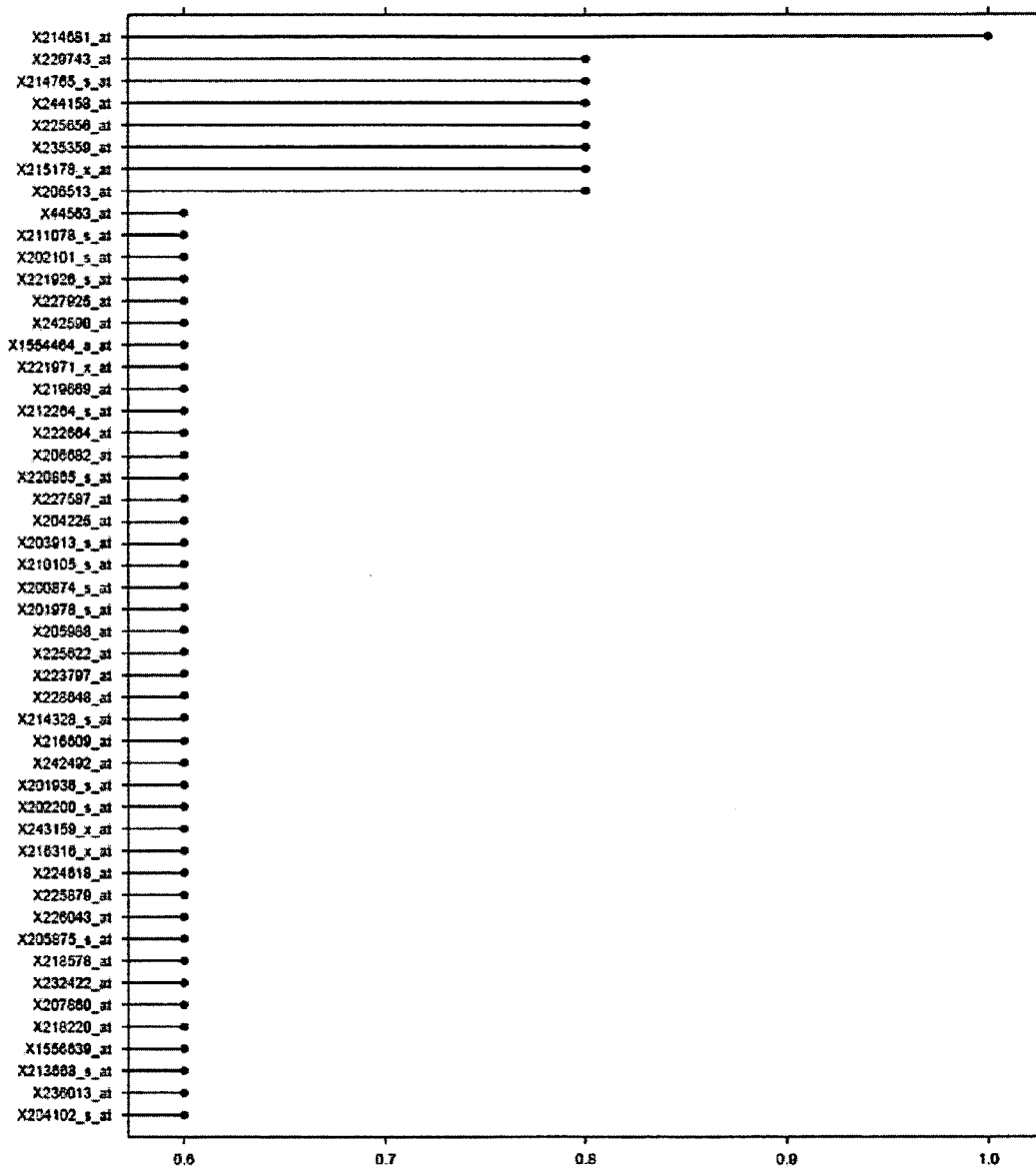

FIG. 19



Percent of time each biomarker was selected

FIG.20

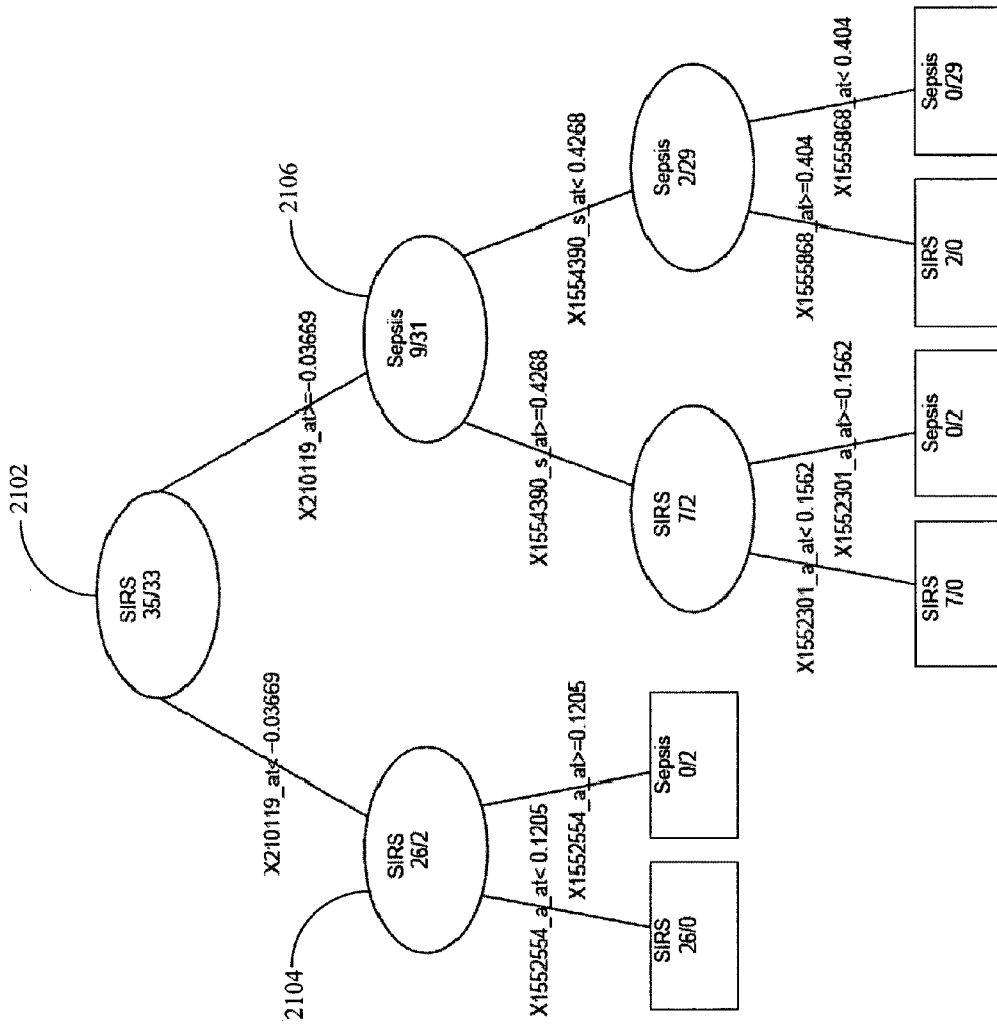

FIG.21

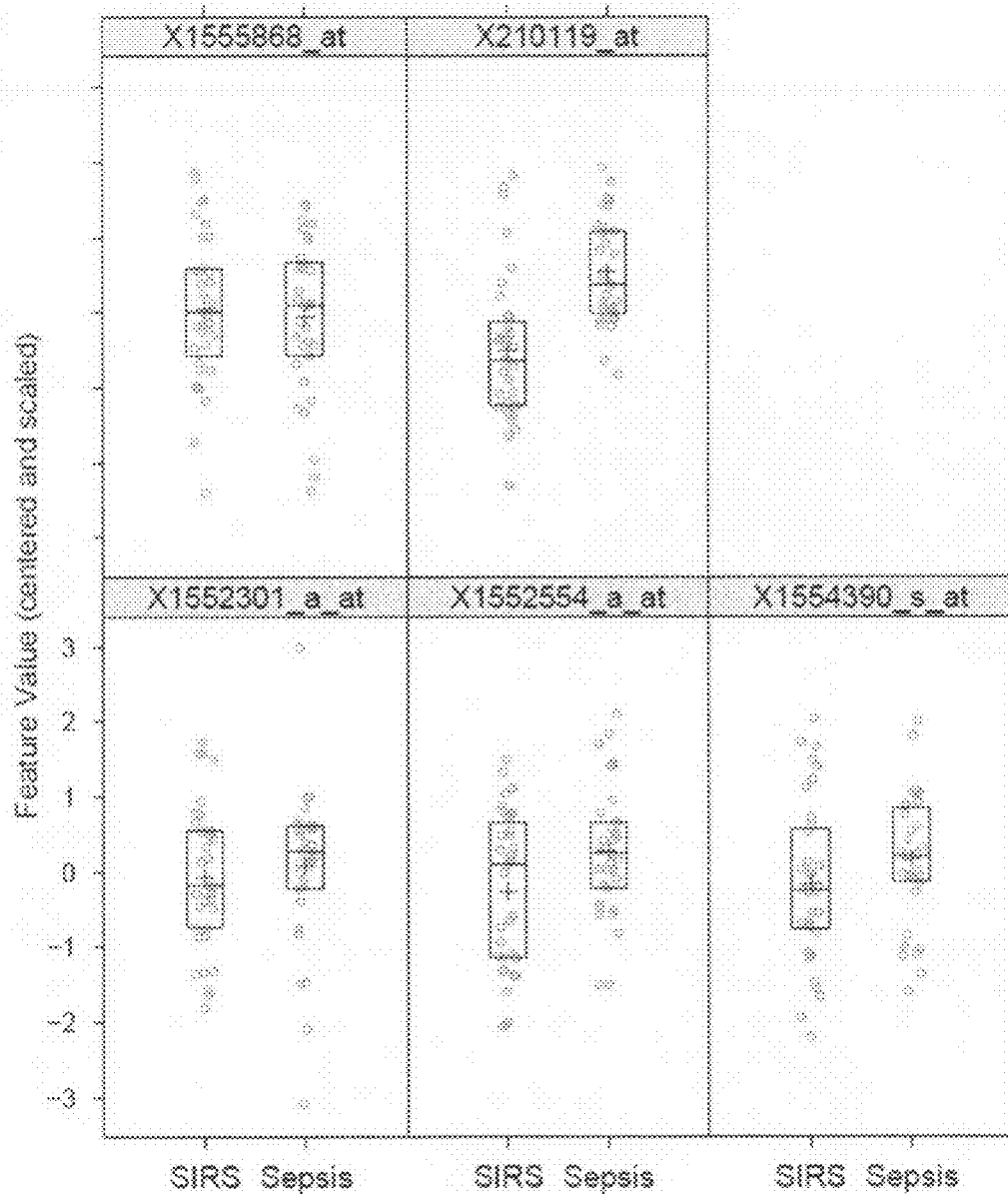

FIG. 22

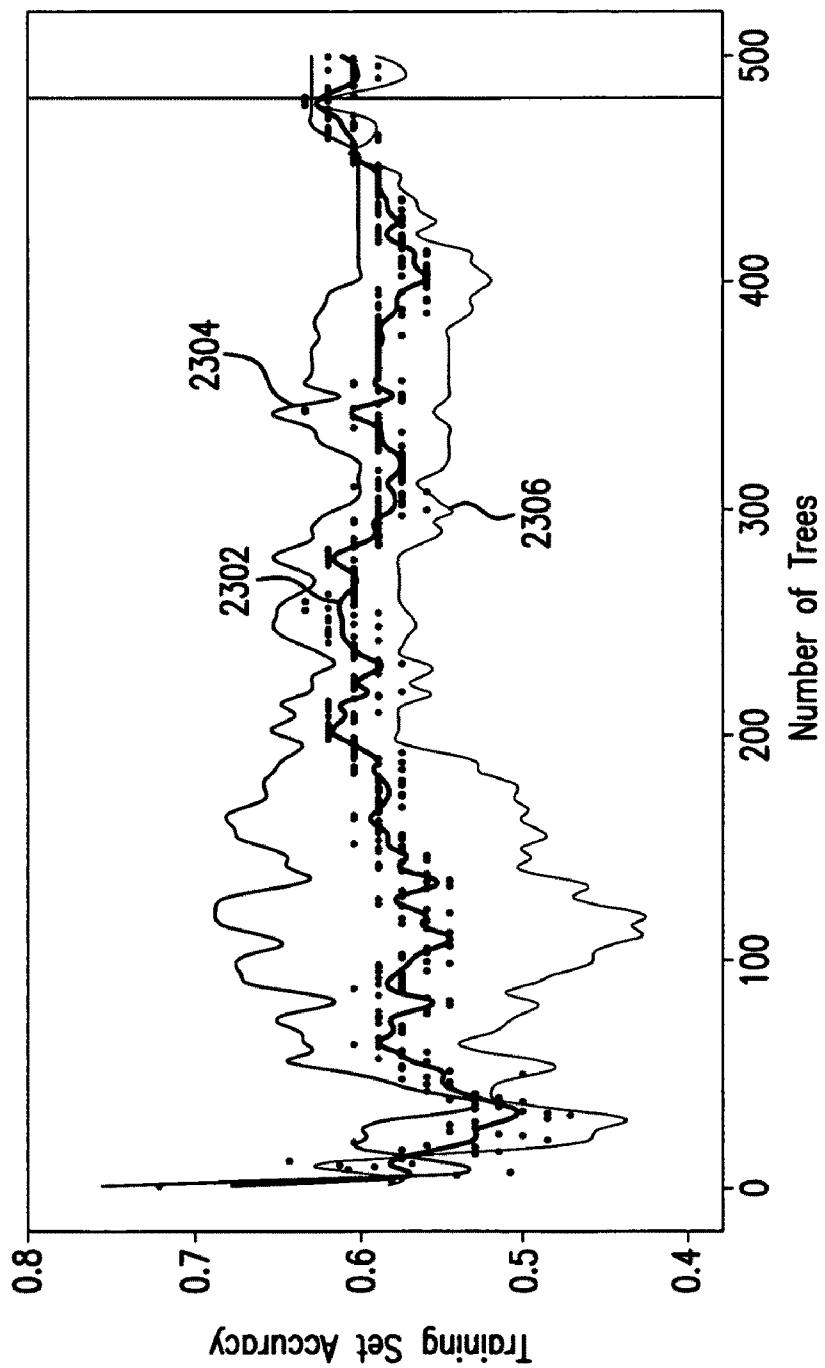

FIG. 23

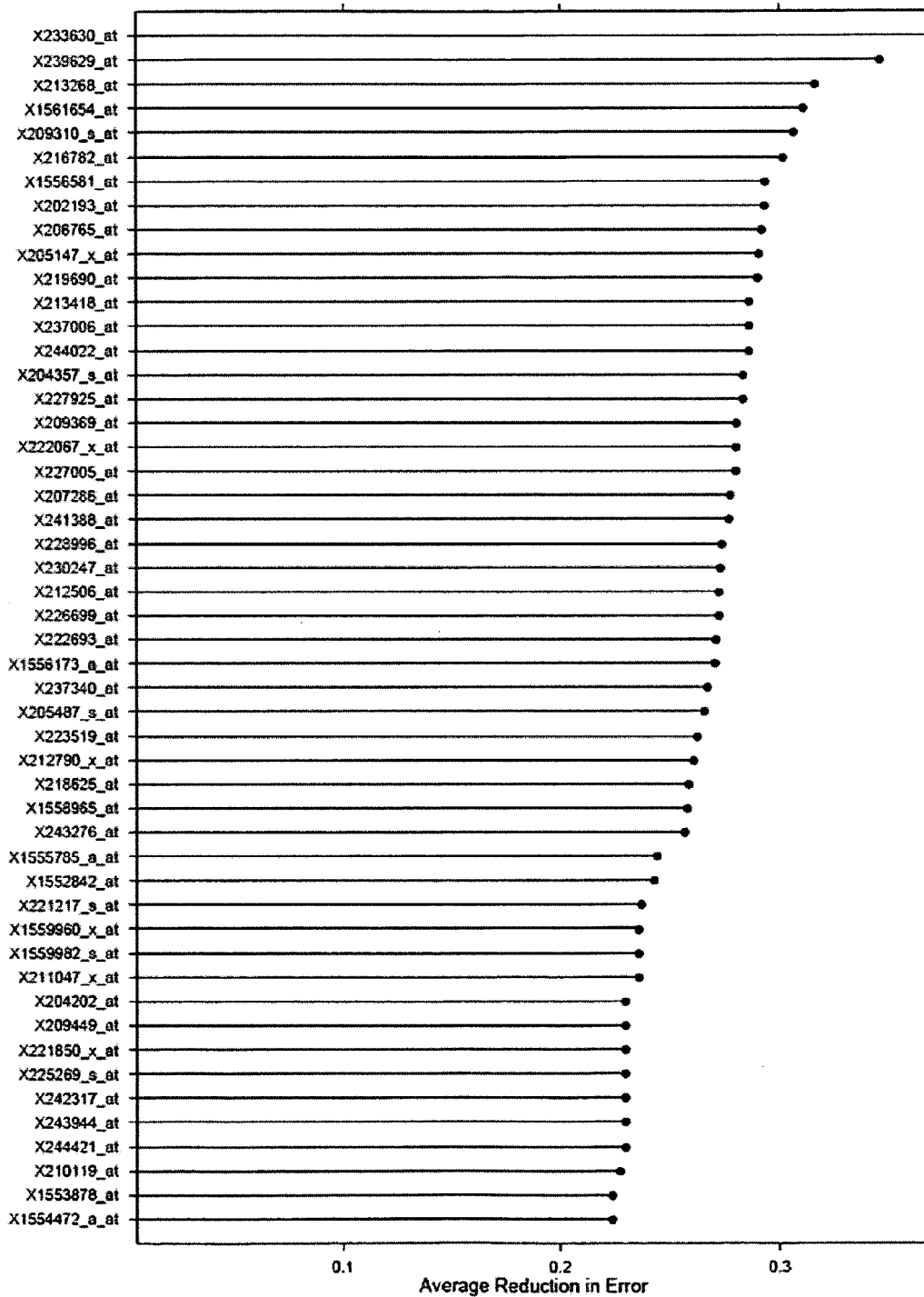
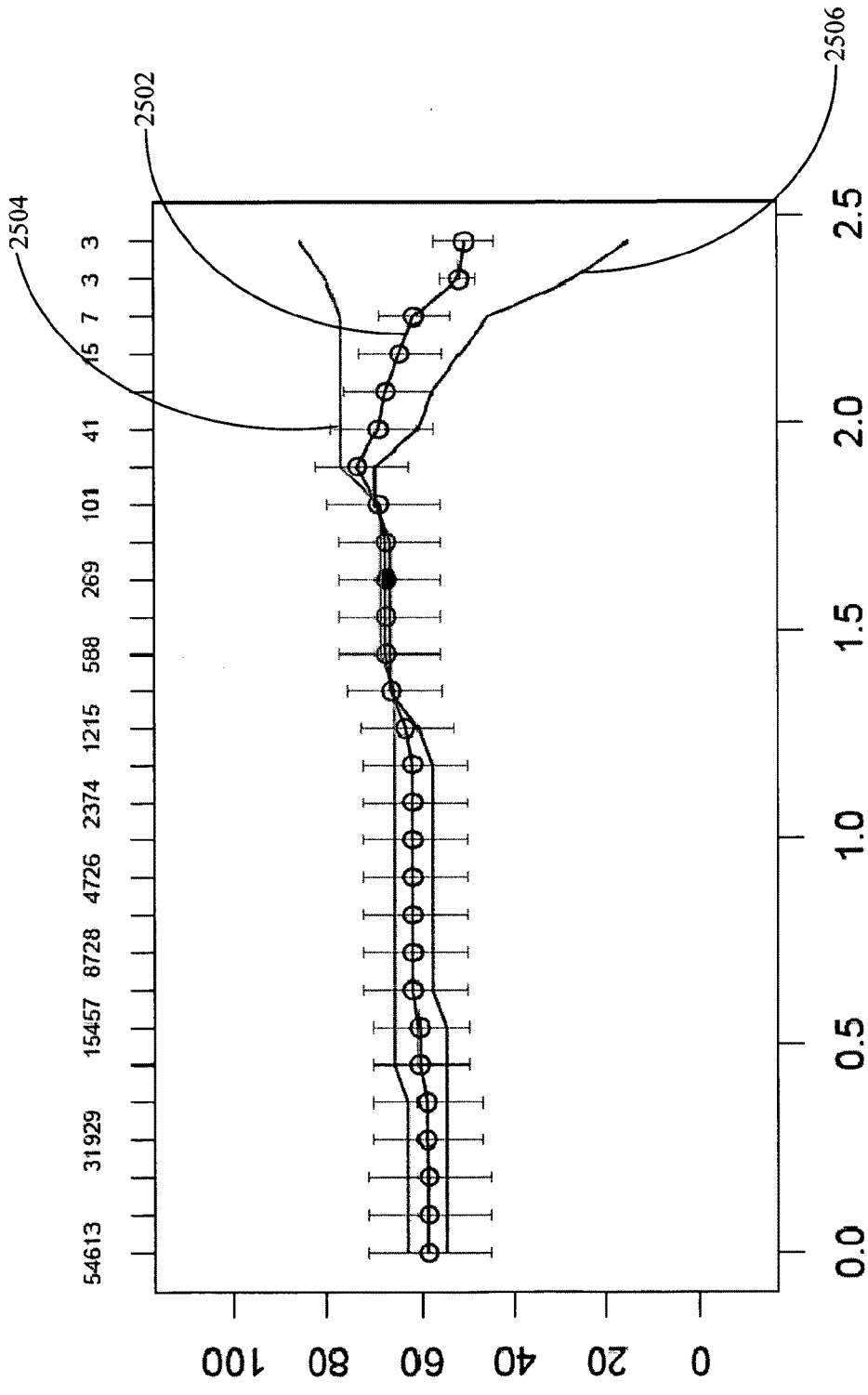

FIG.24



Threshold

FIG.25

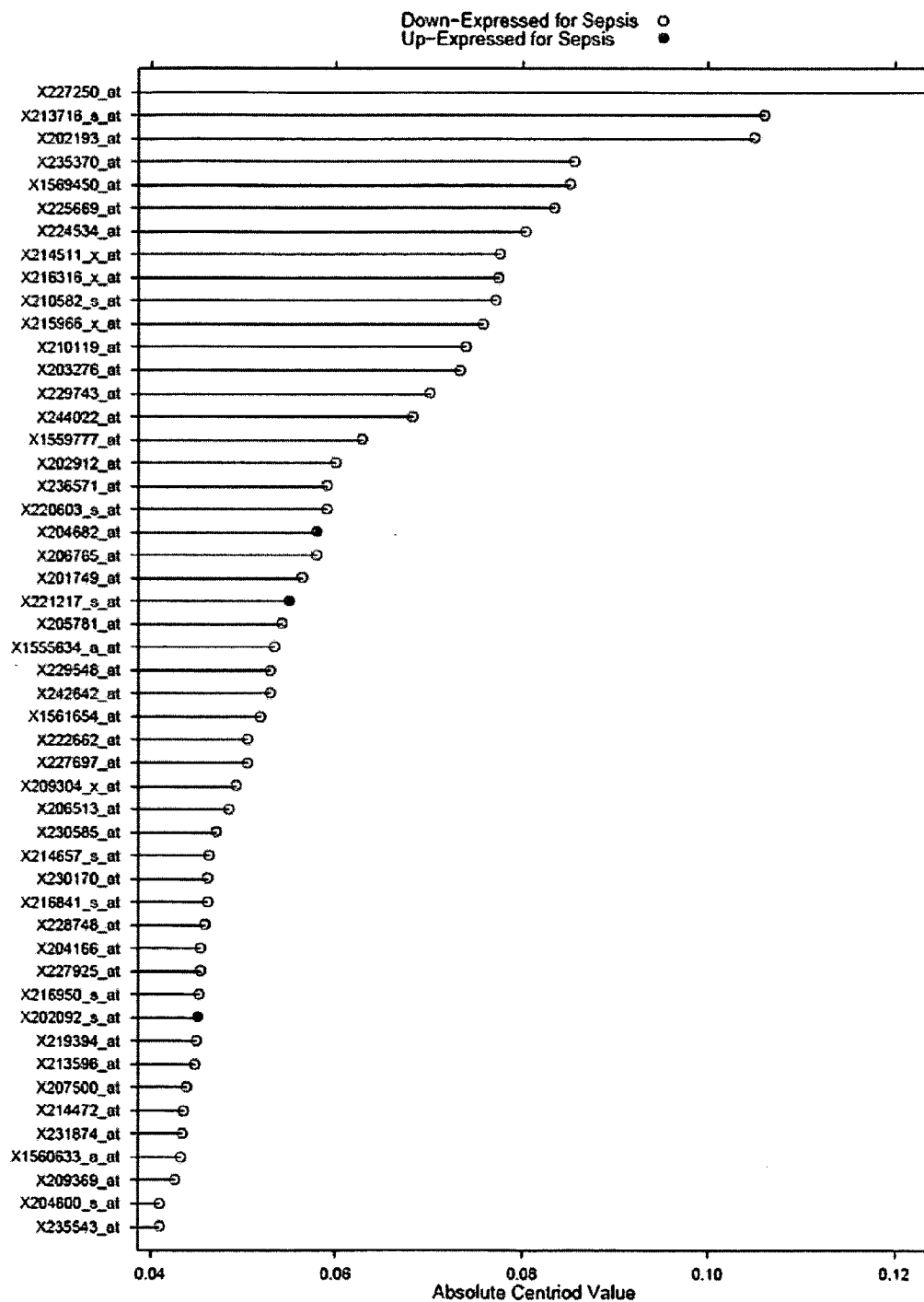

FIG.26

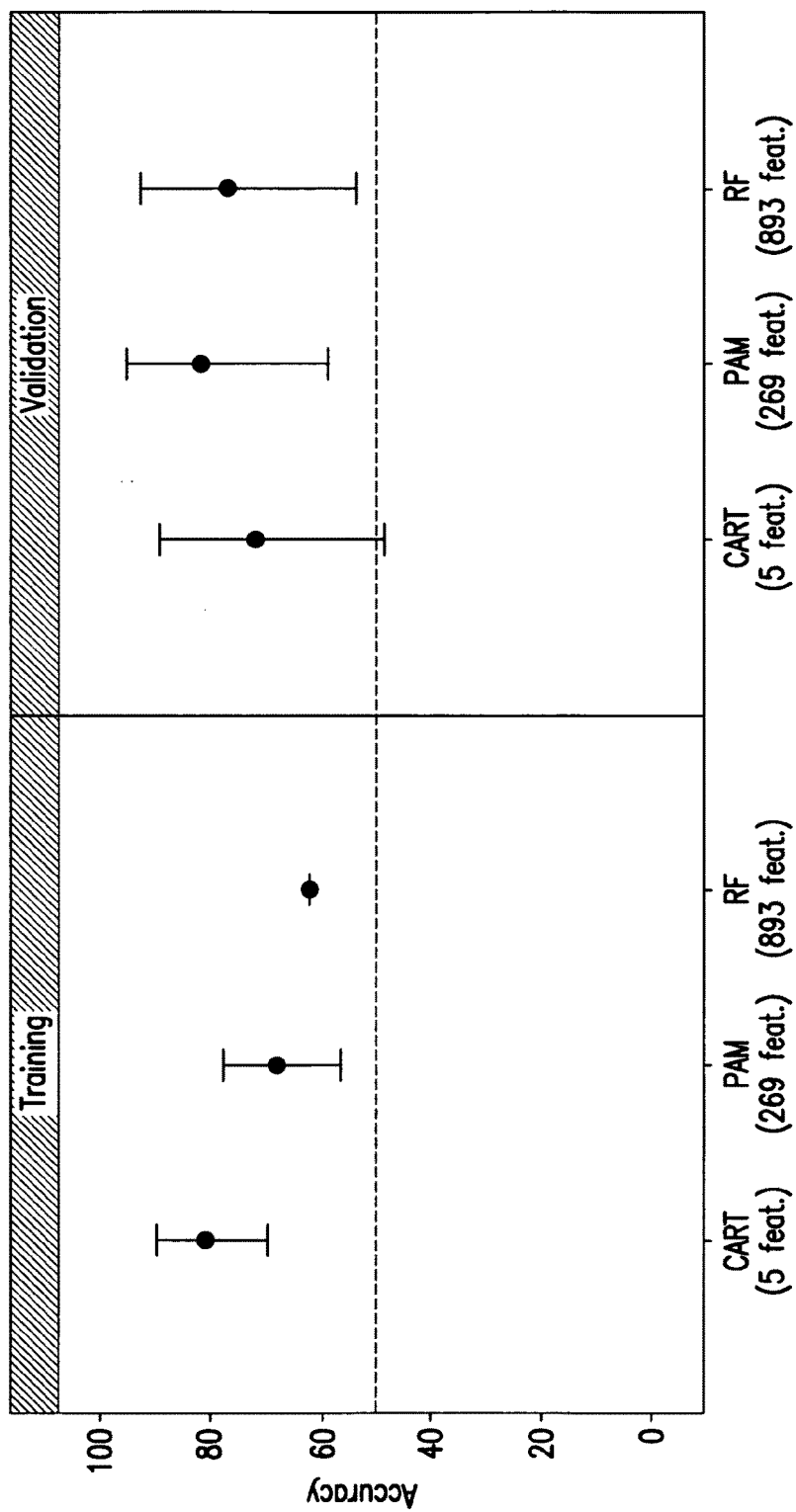

FIG. 27

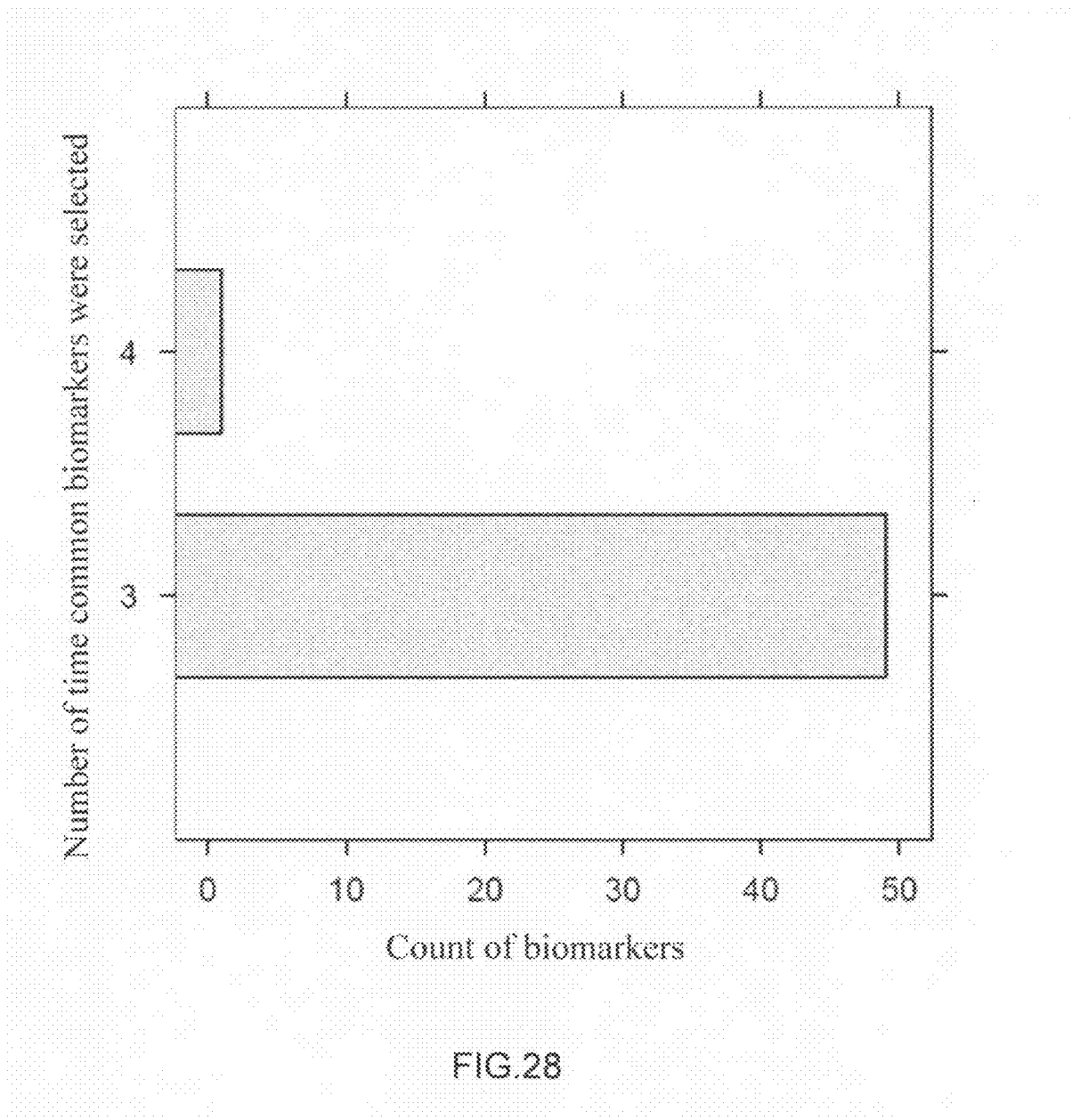

FIG.28

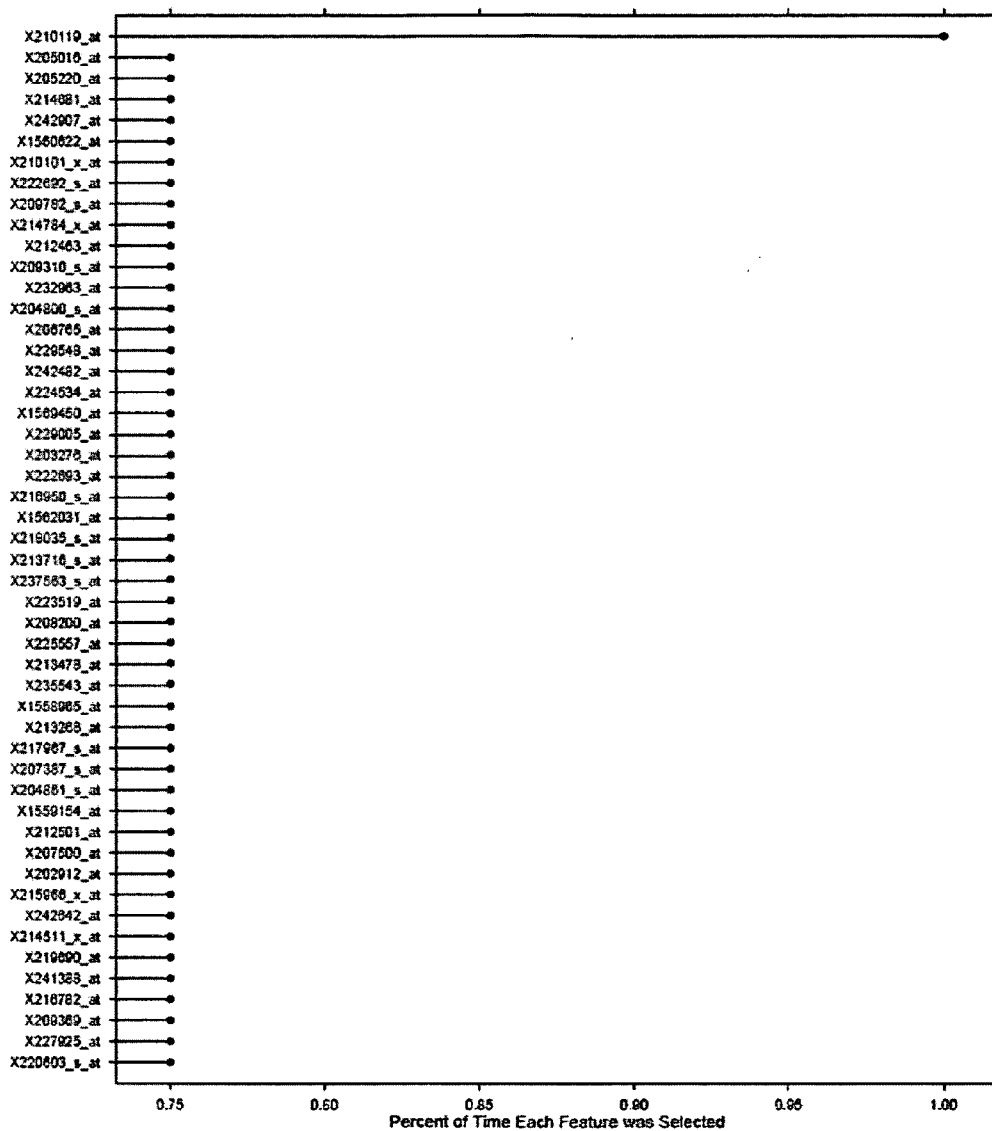

FIG.29

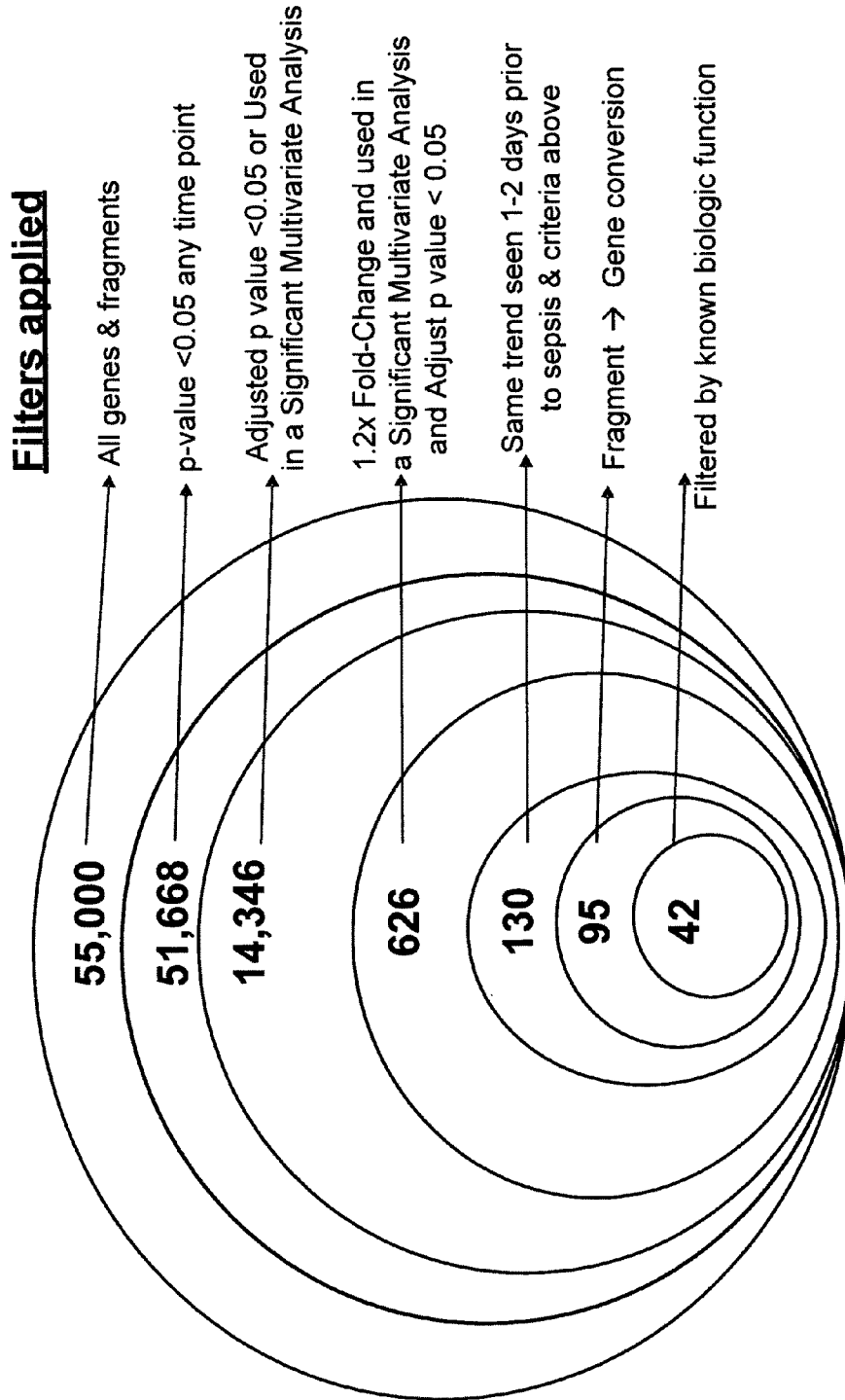

FIG.30

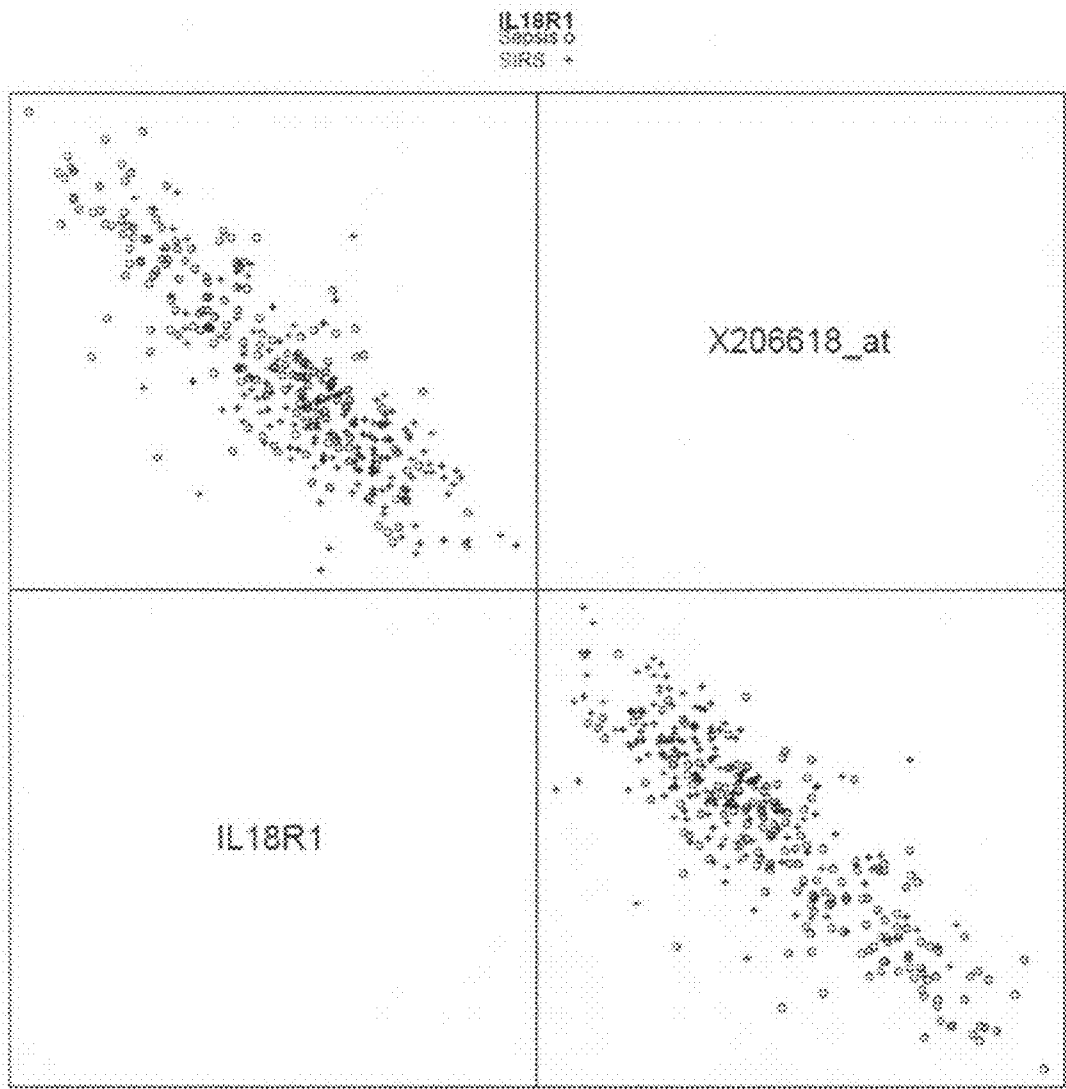

FIG.31

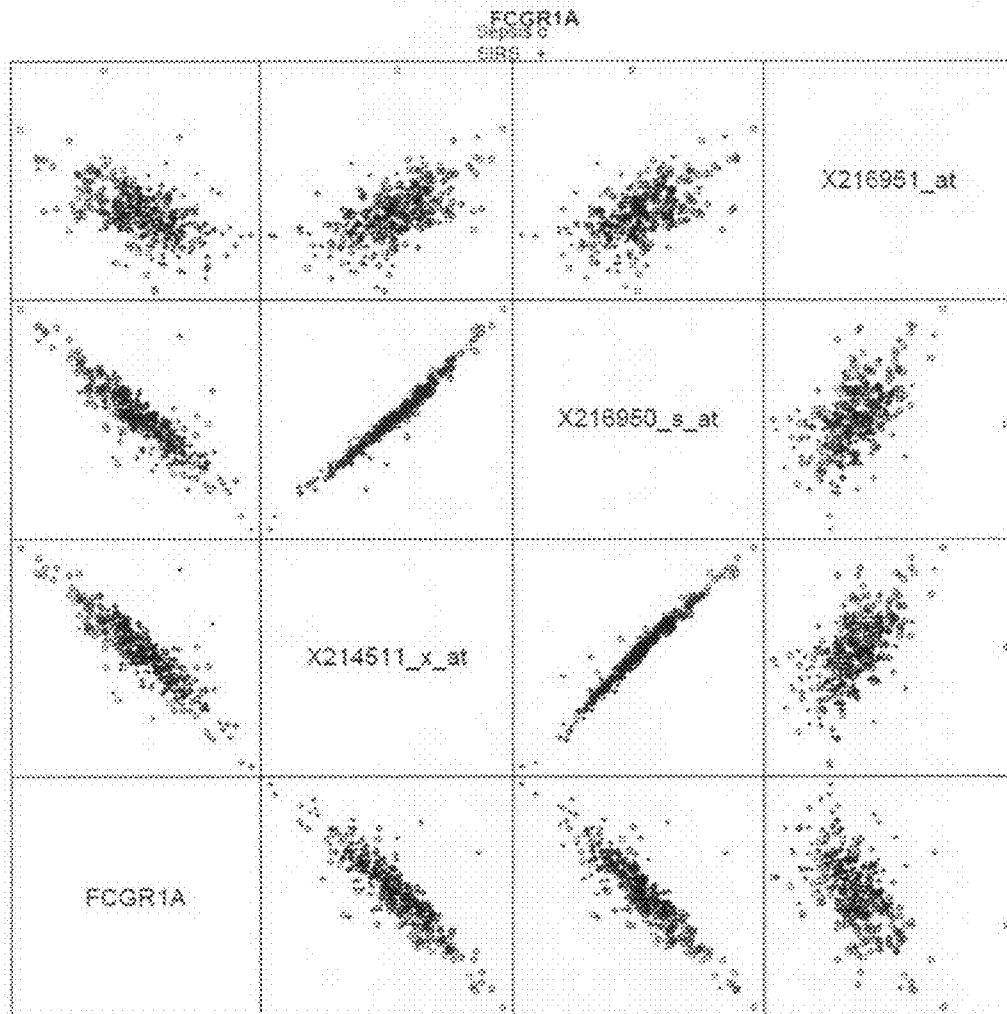
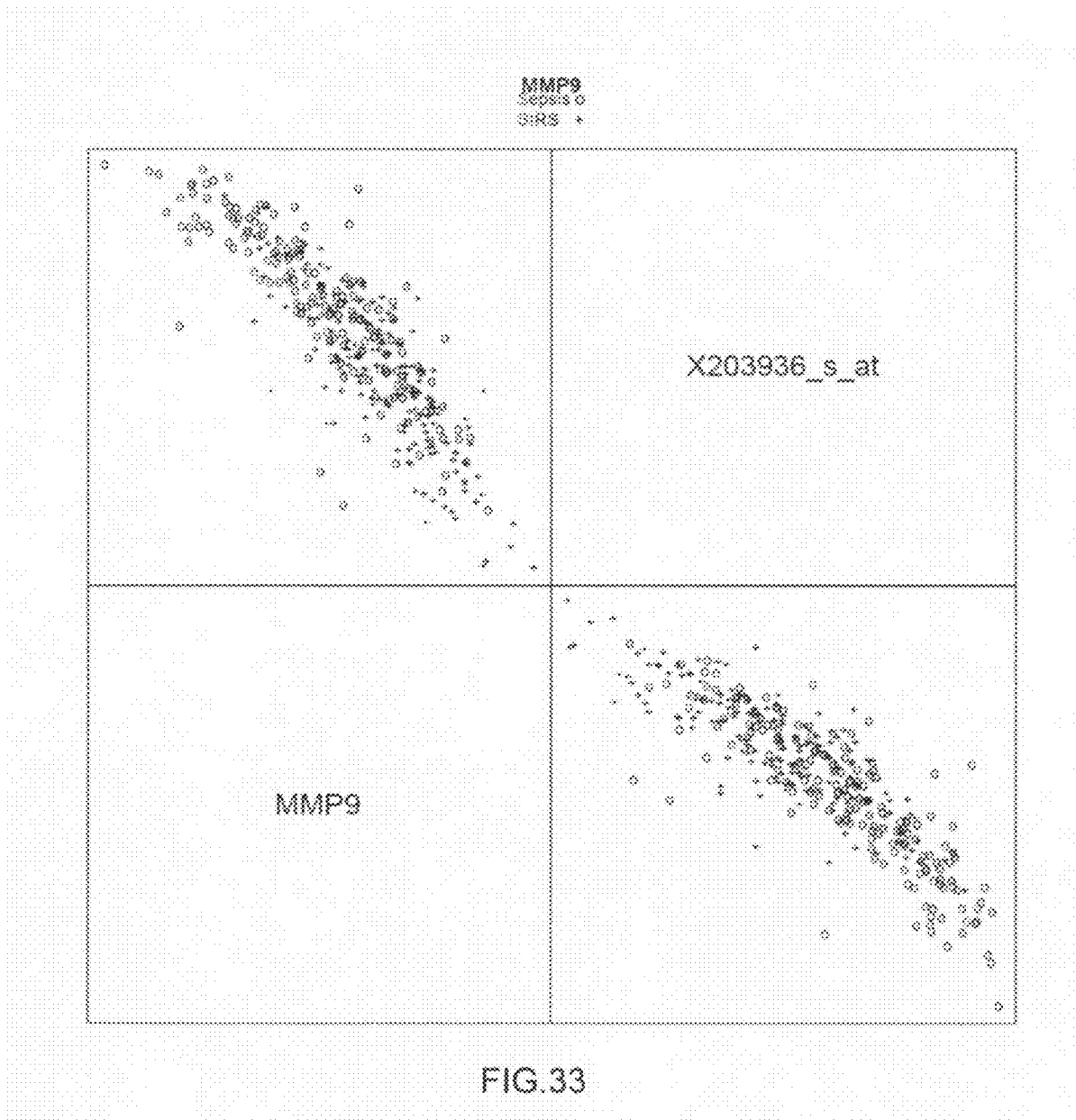

FIG.32



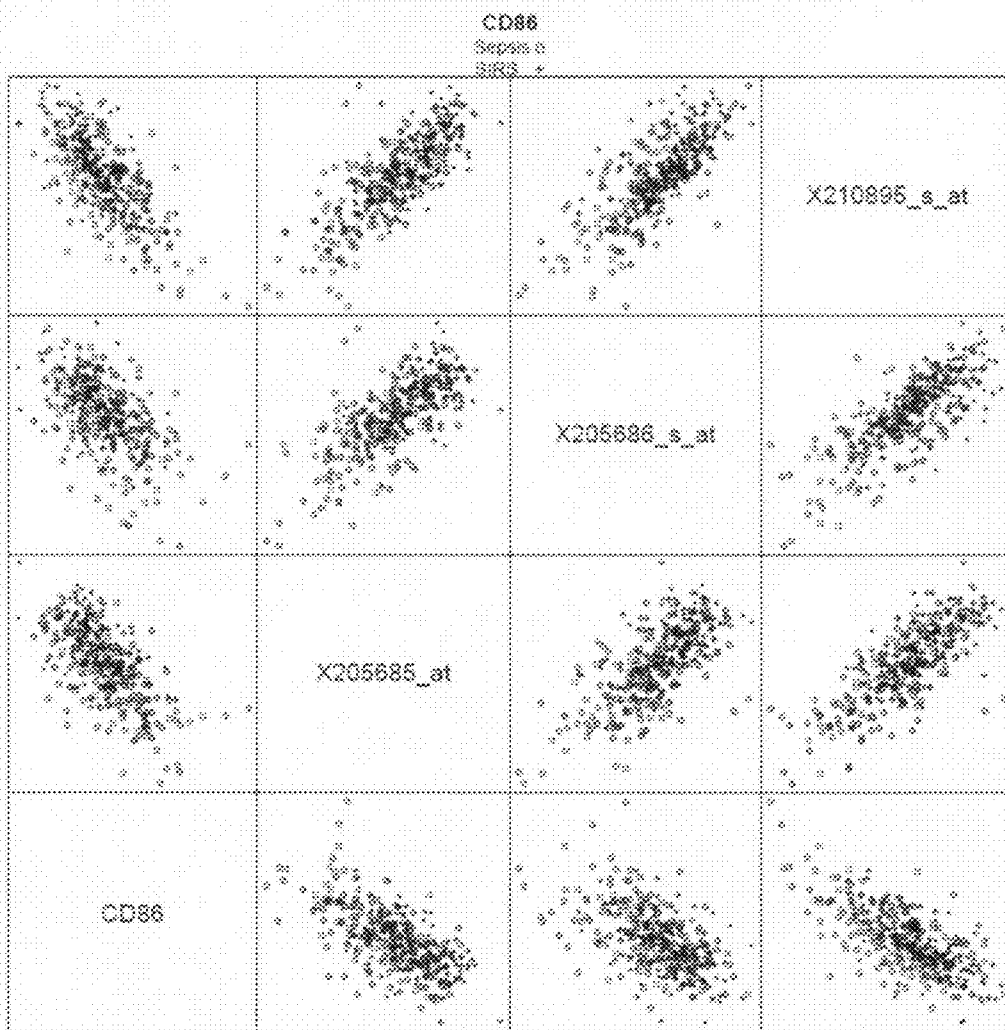

FIG.34

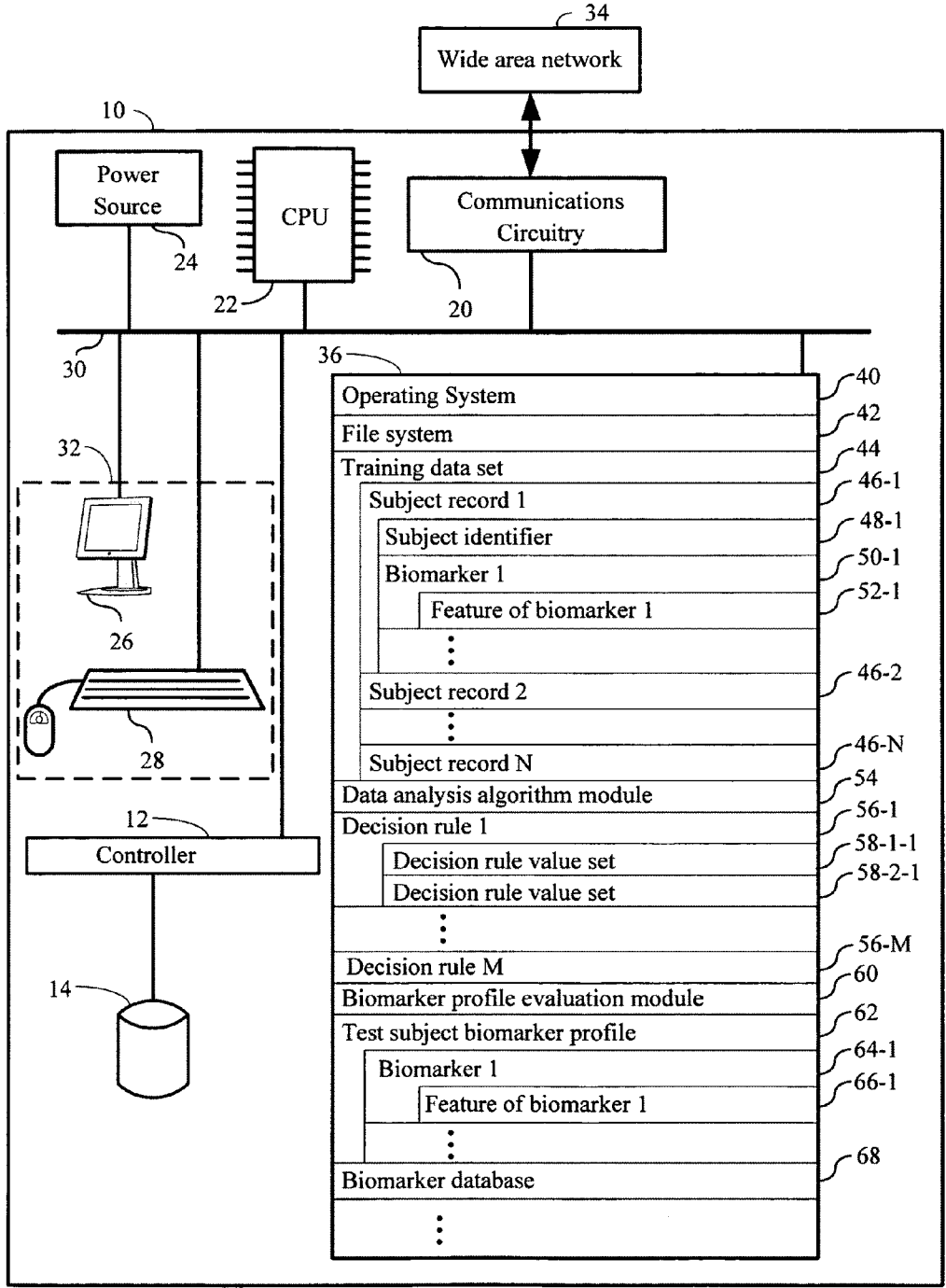

FIG.35

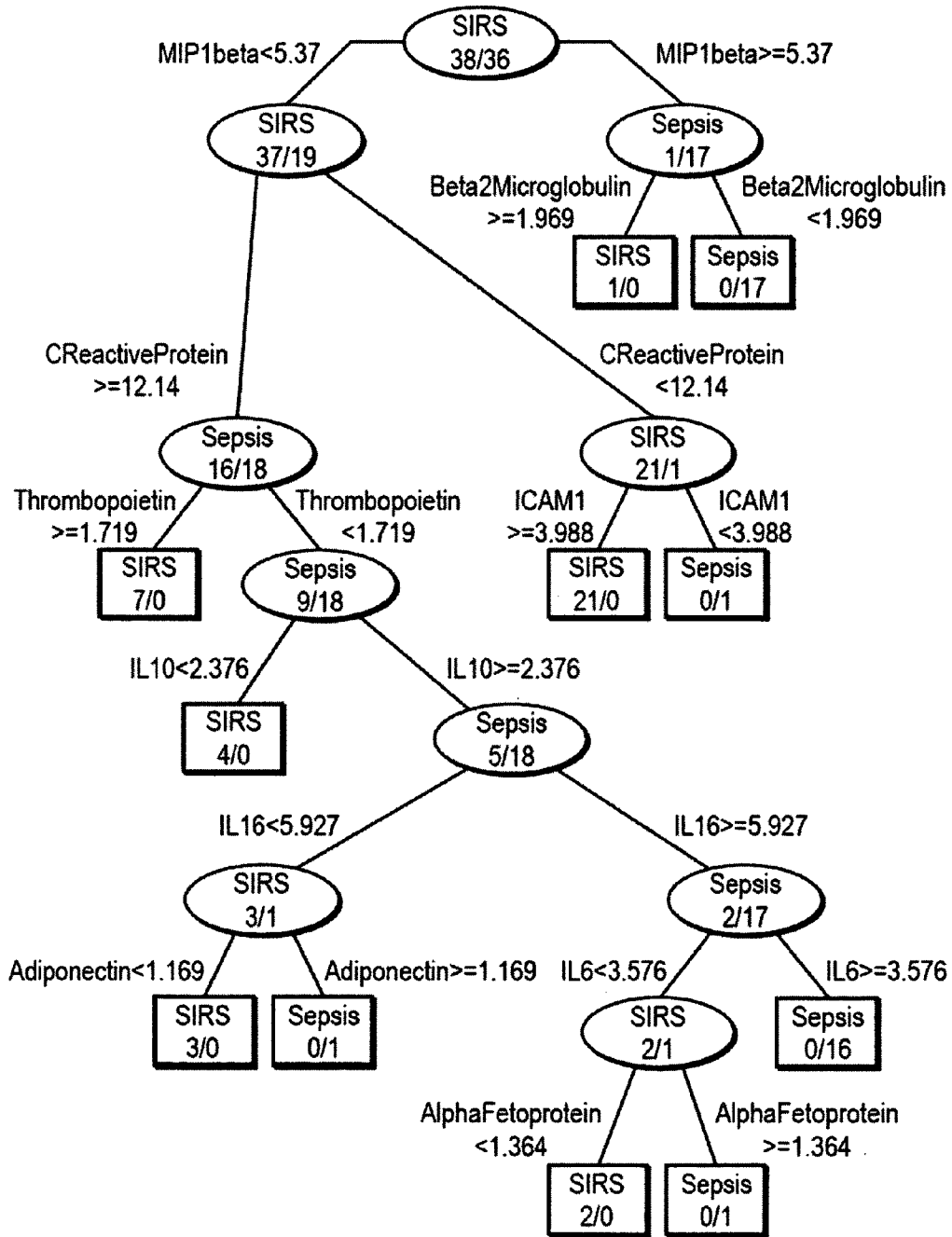

FIG. 36

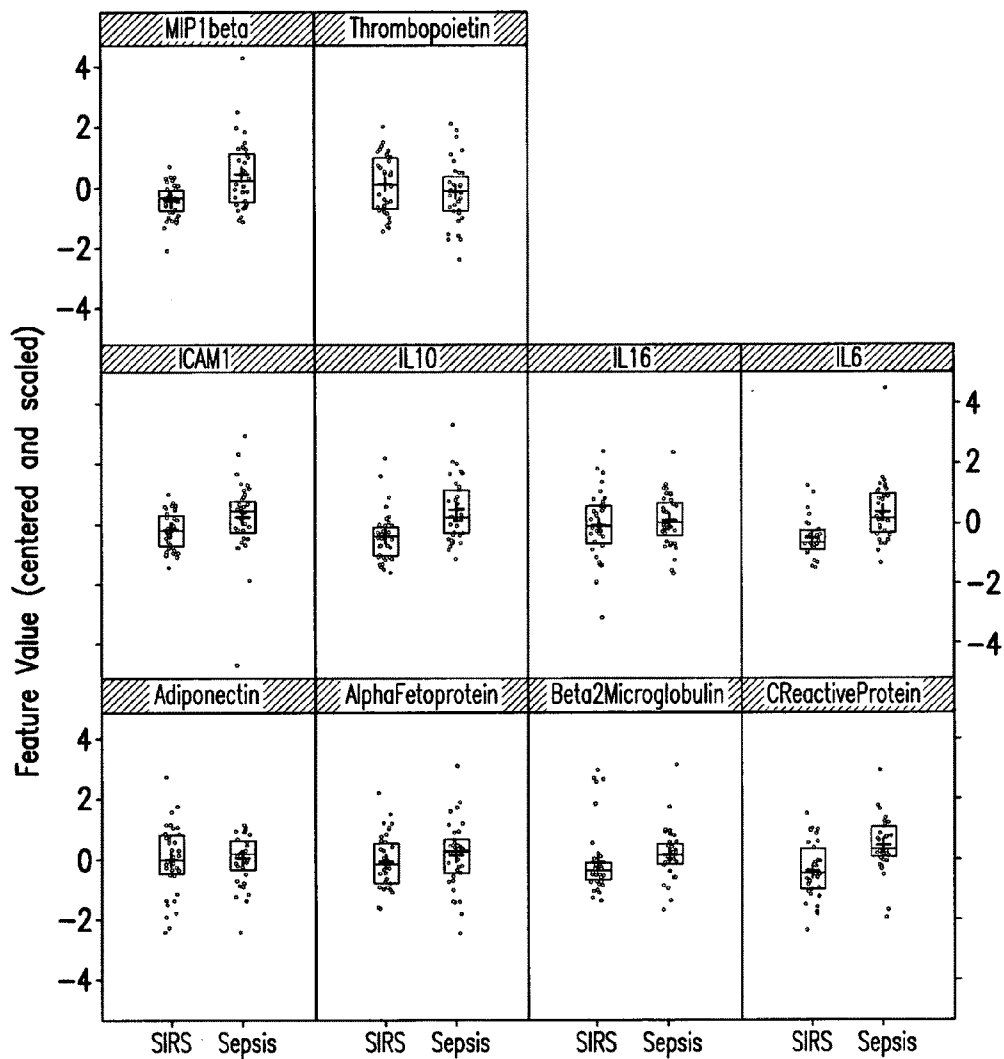

FIG.37

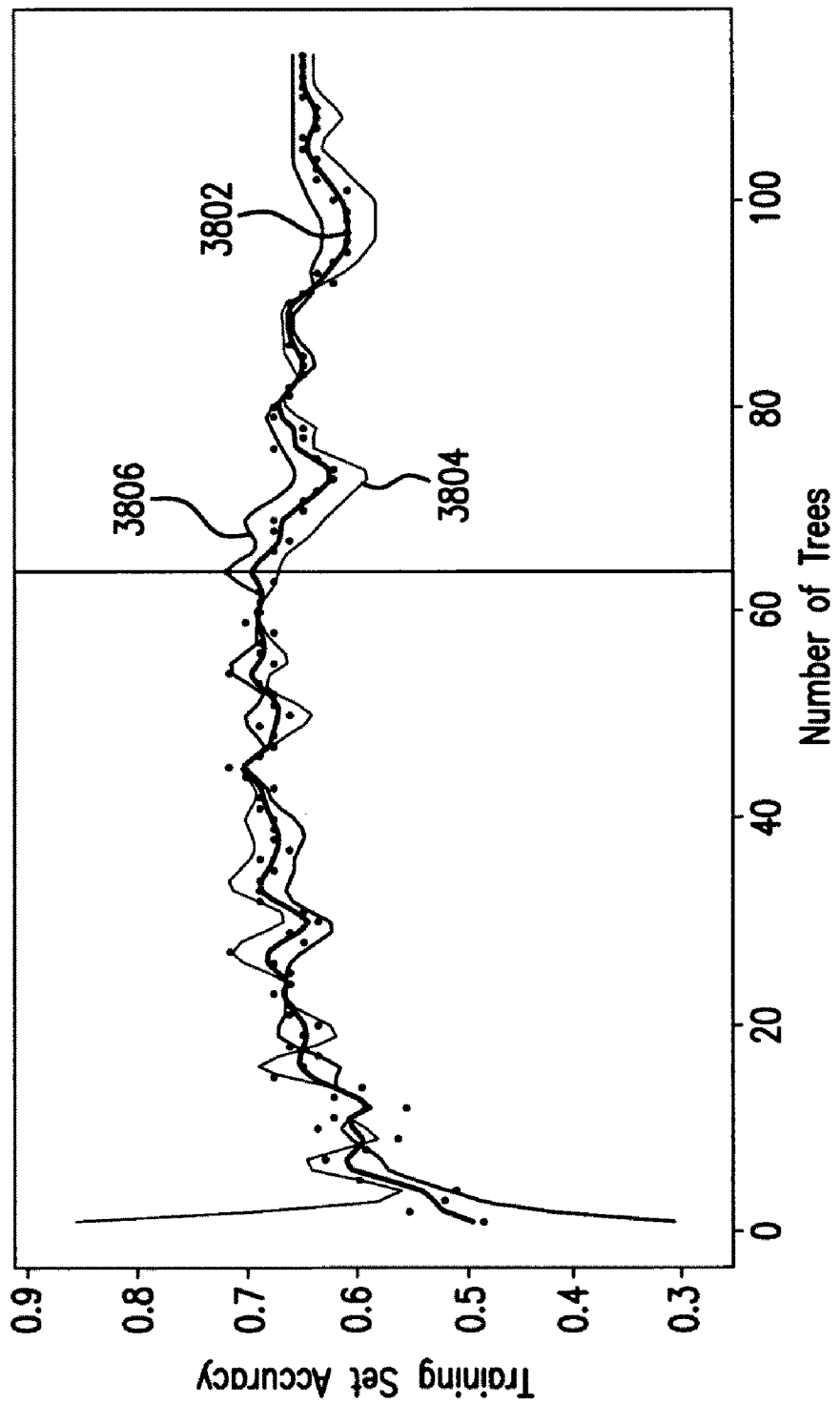

FIG. 38

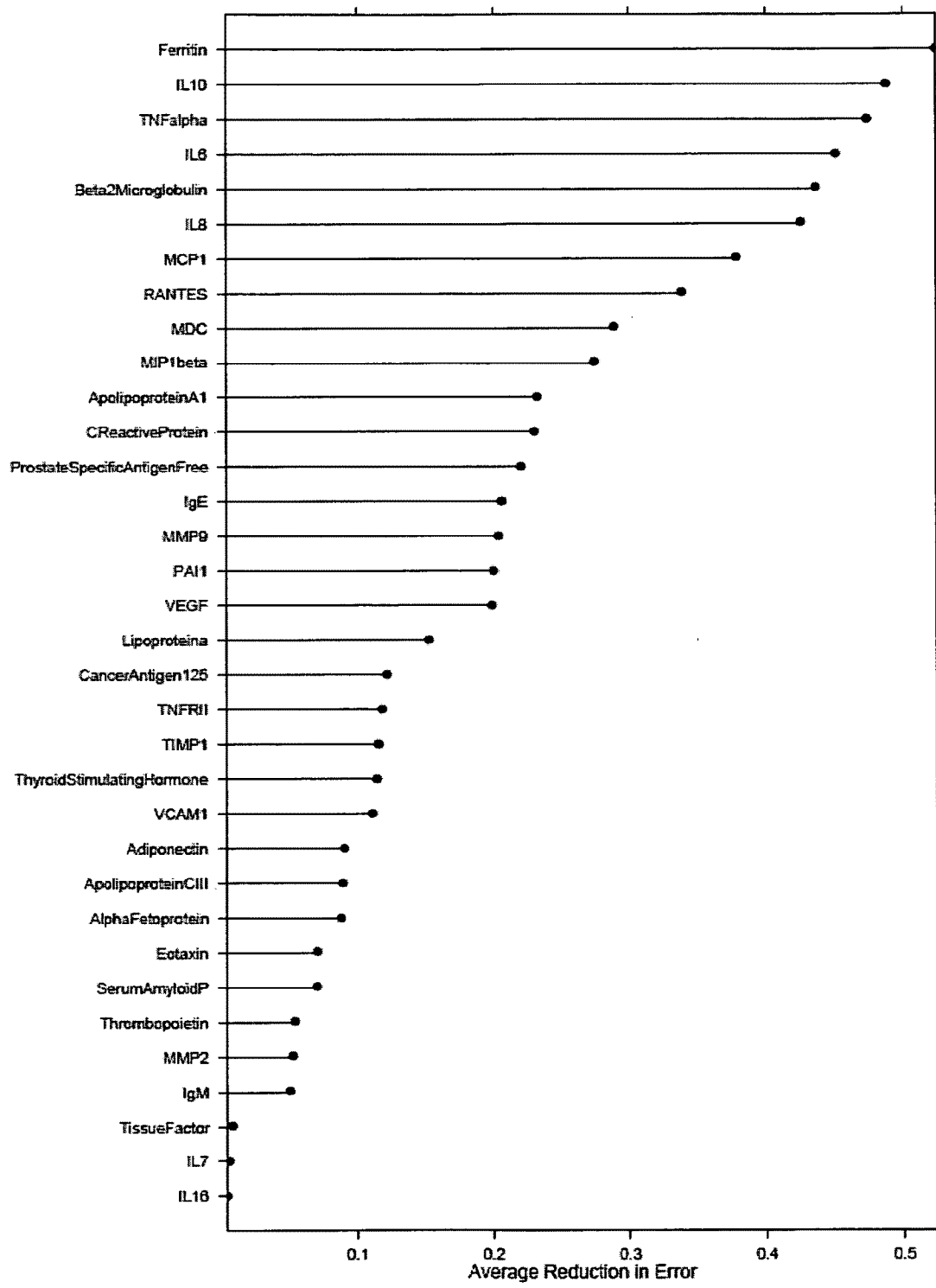

FIG. 39

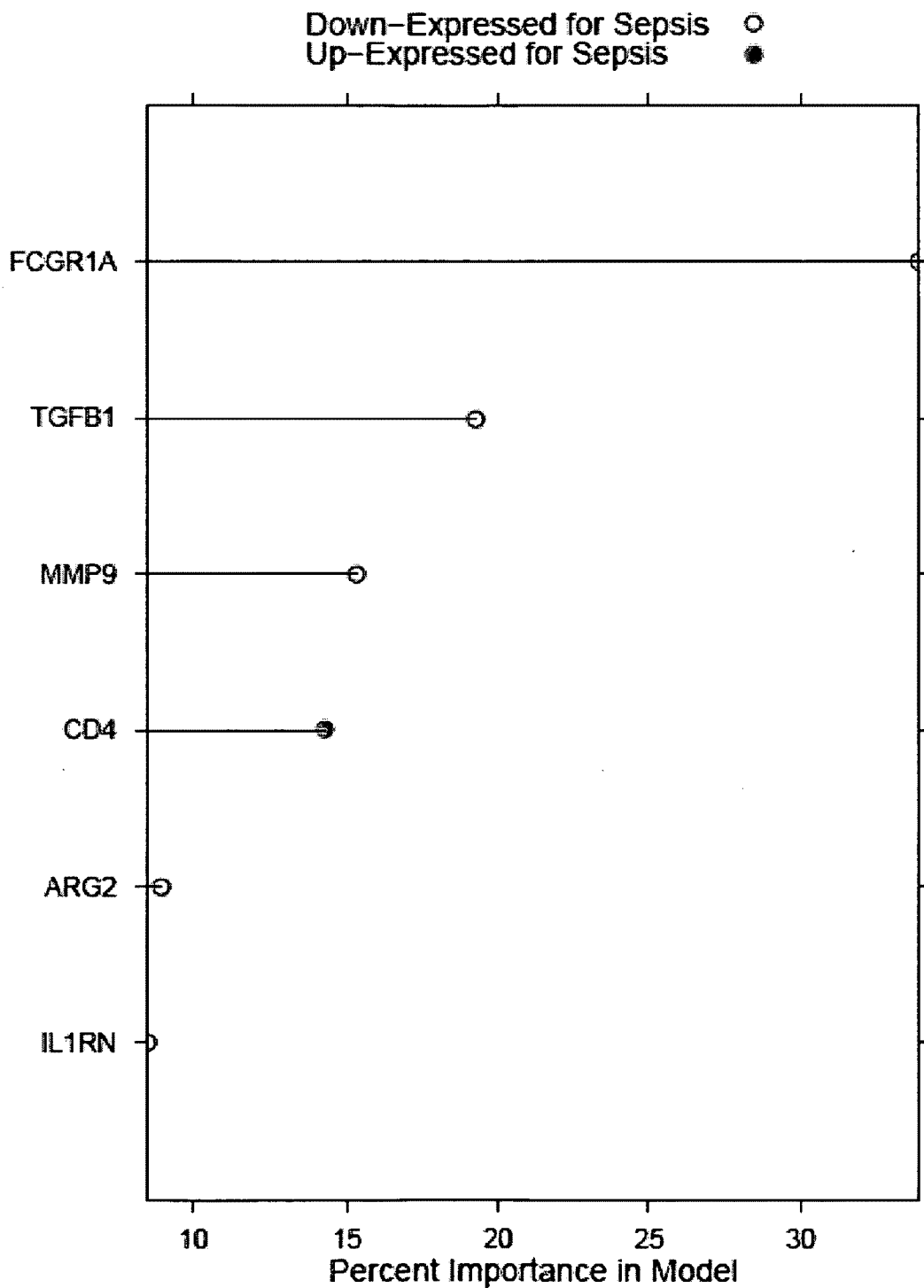

FIG. 40

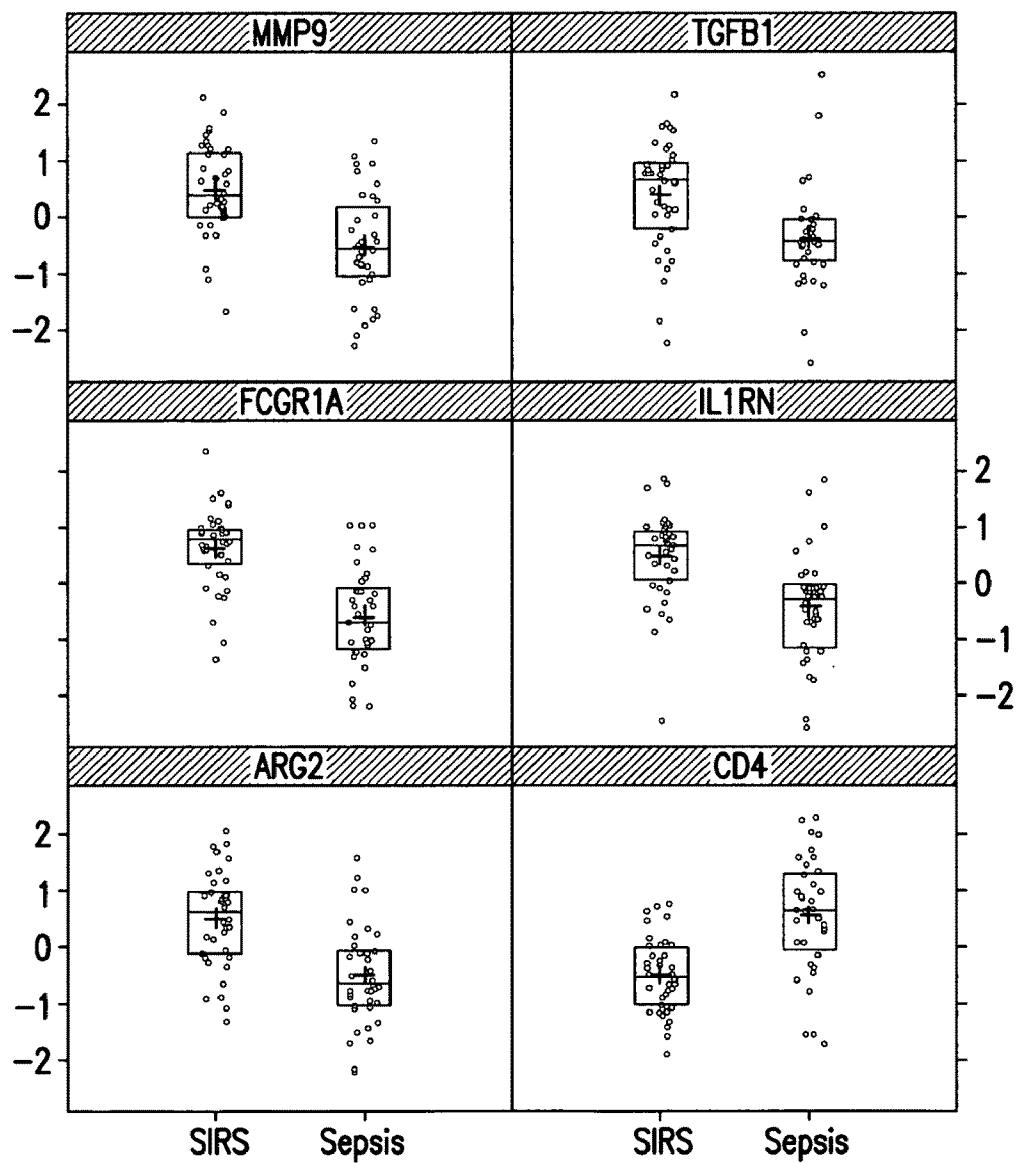

FIG.41

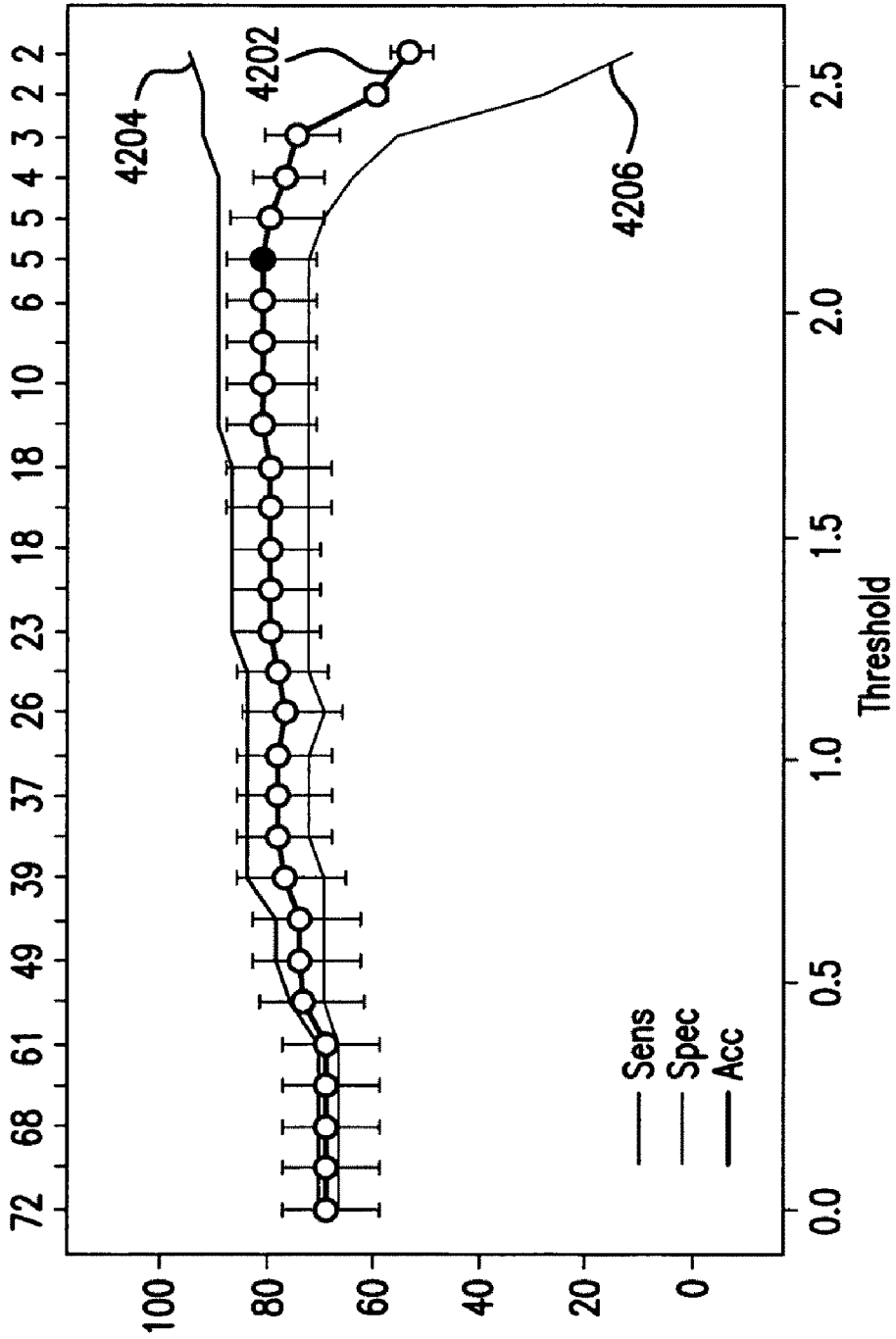

FIG.42

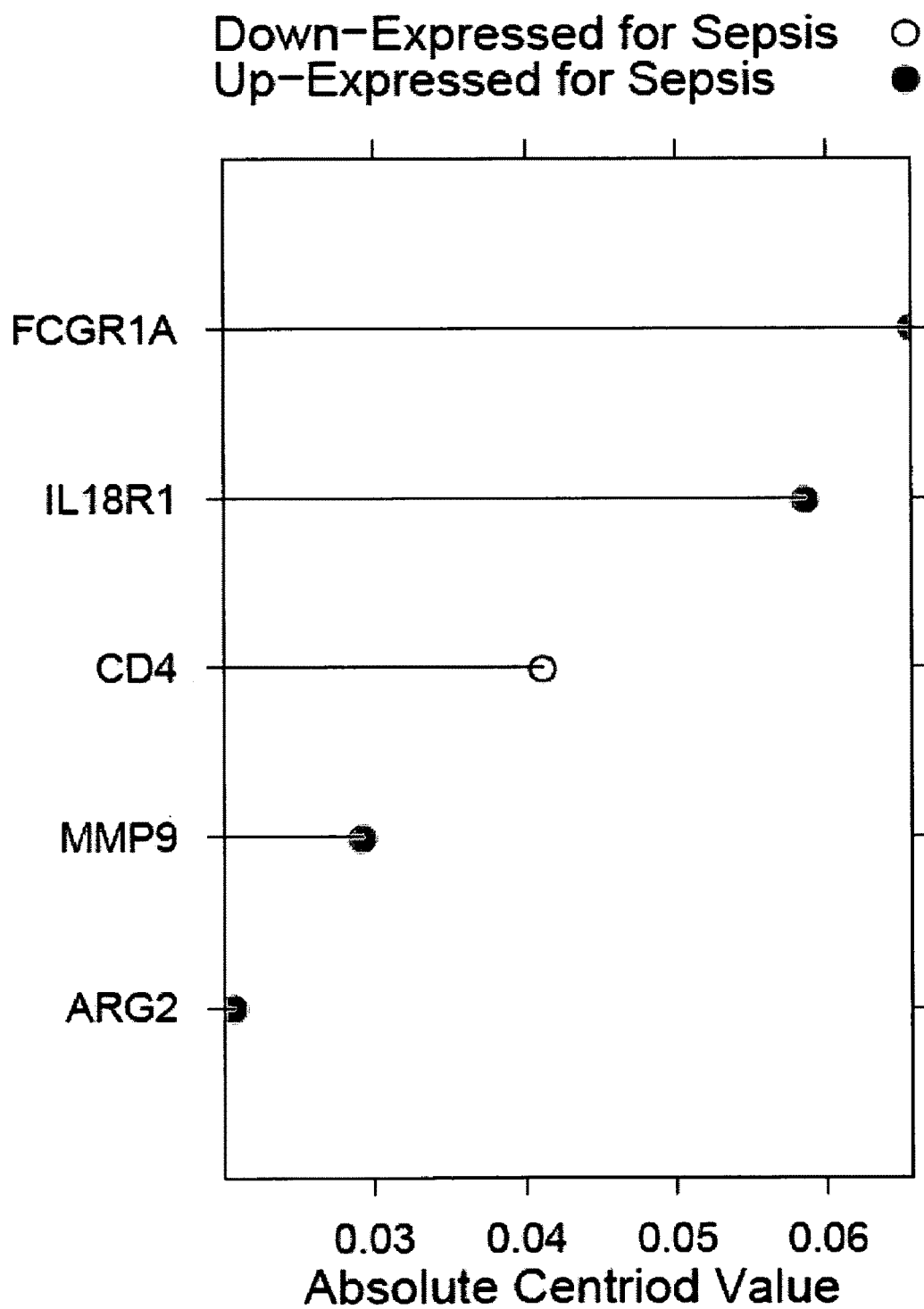

FIG. 43

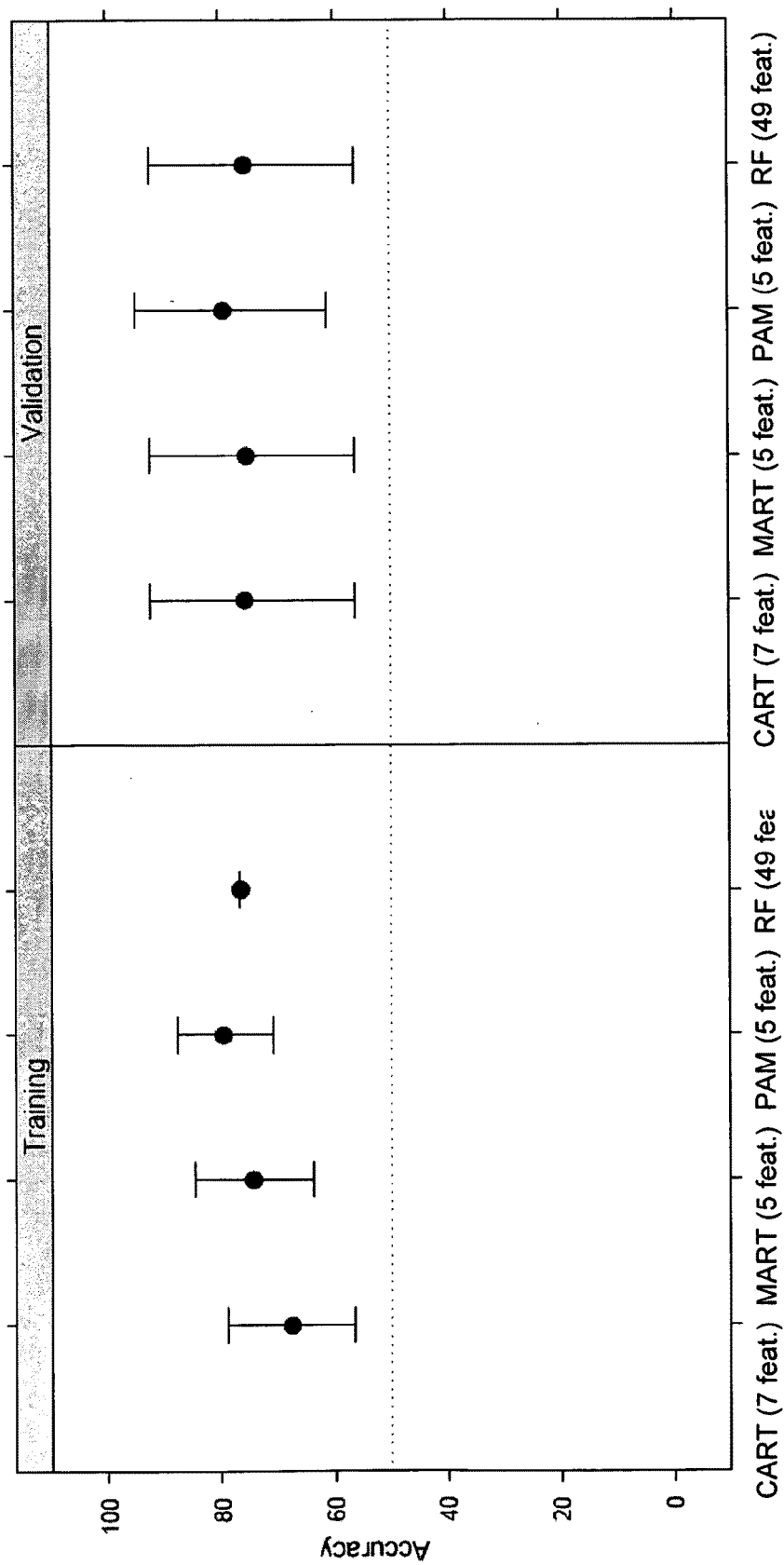

FIG. 44

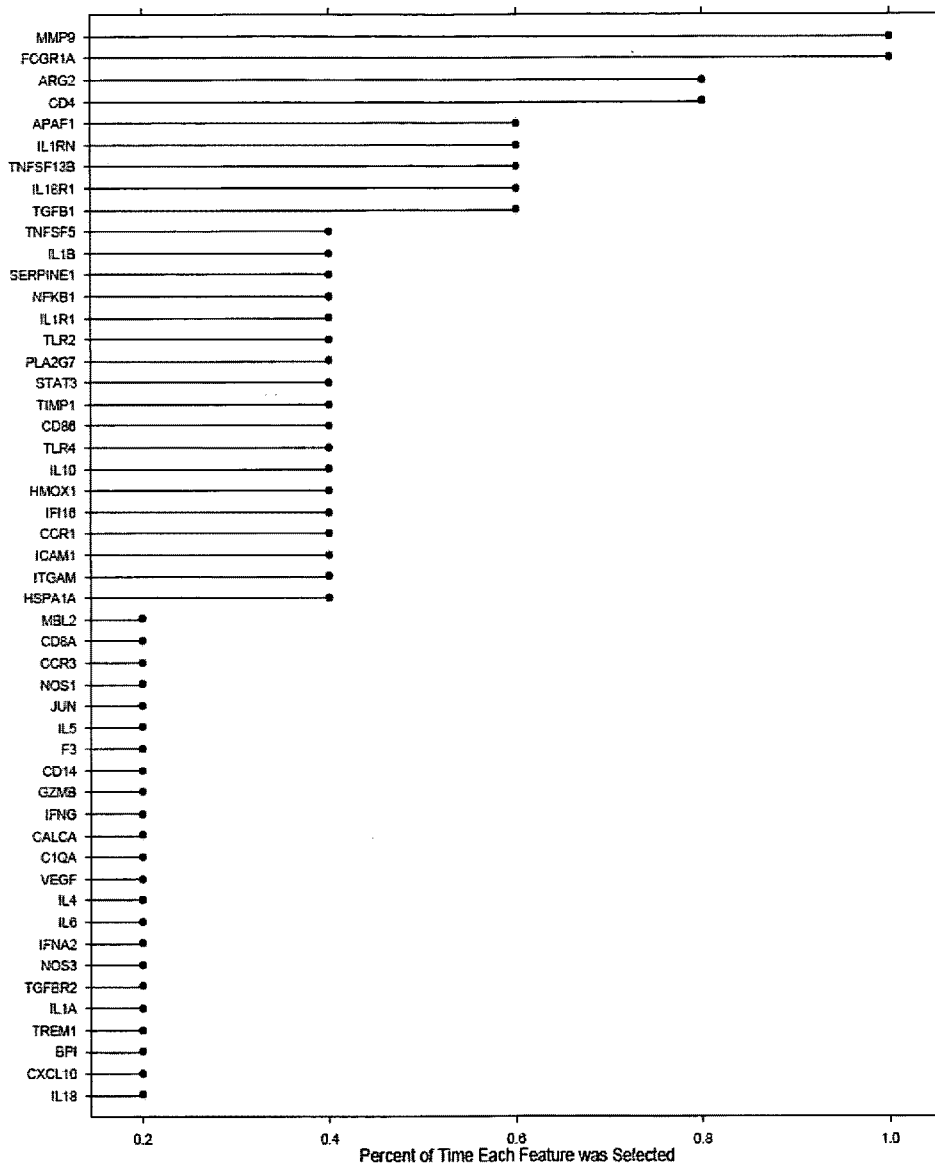

FIG. 45

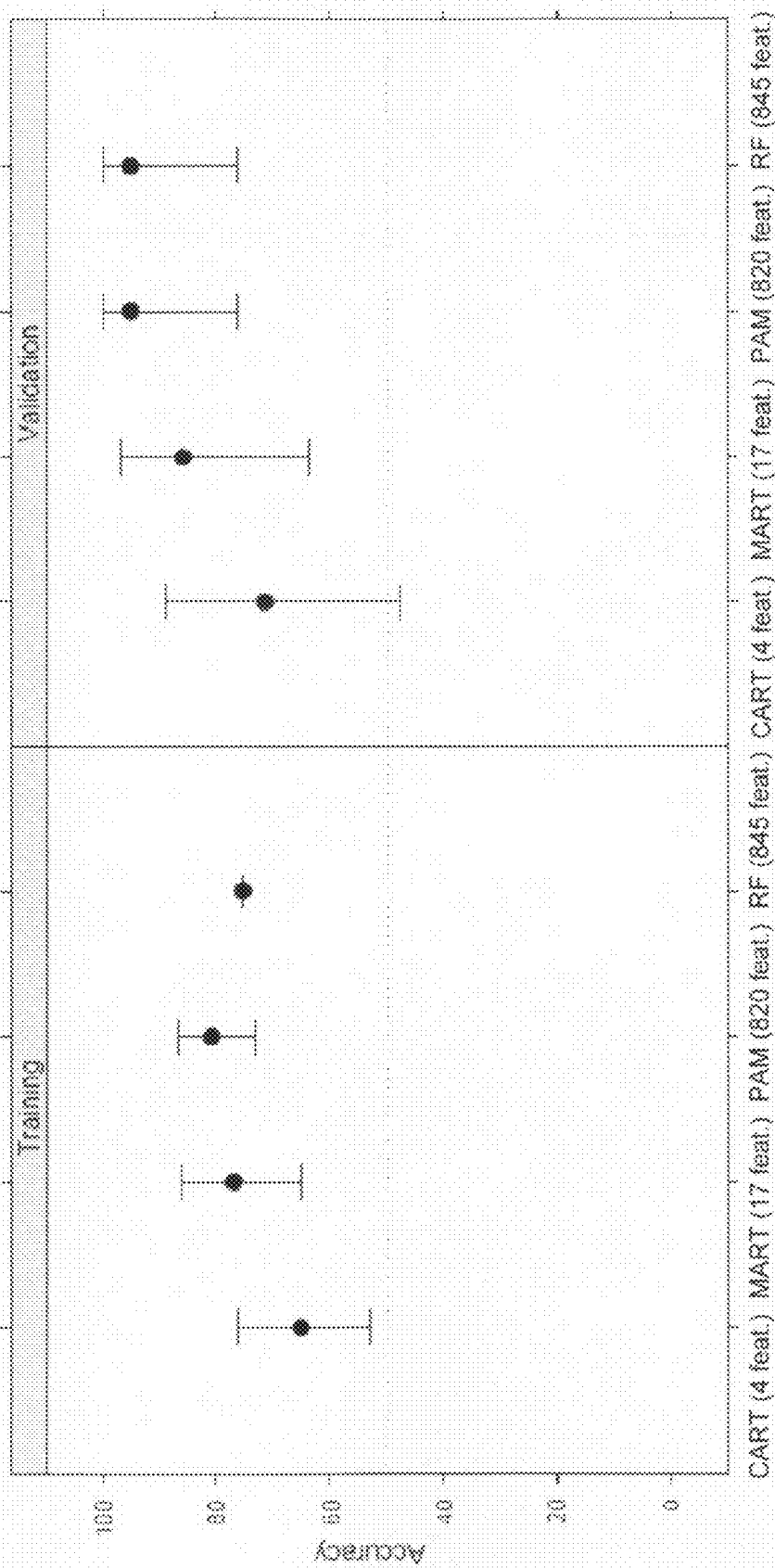

FIG. 46

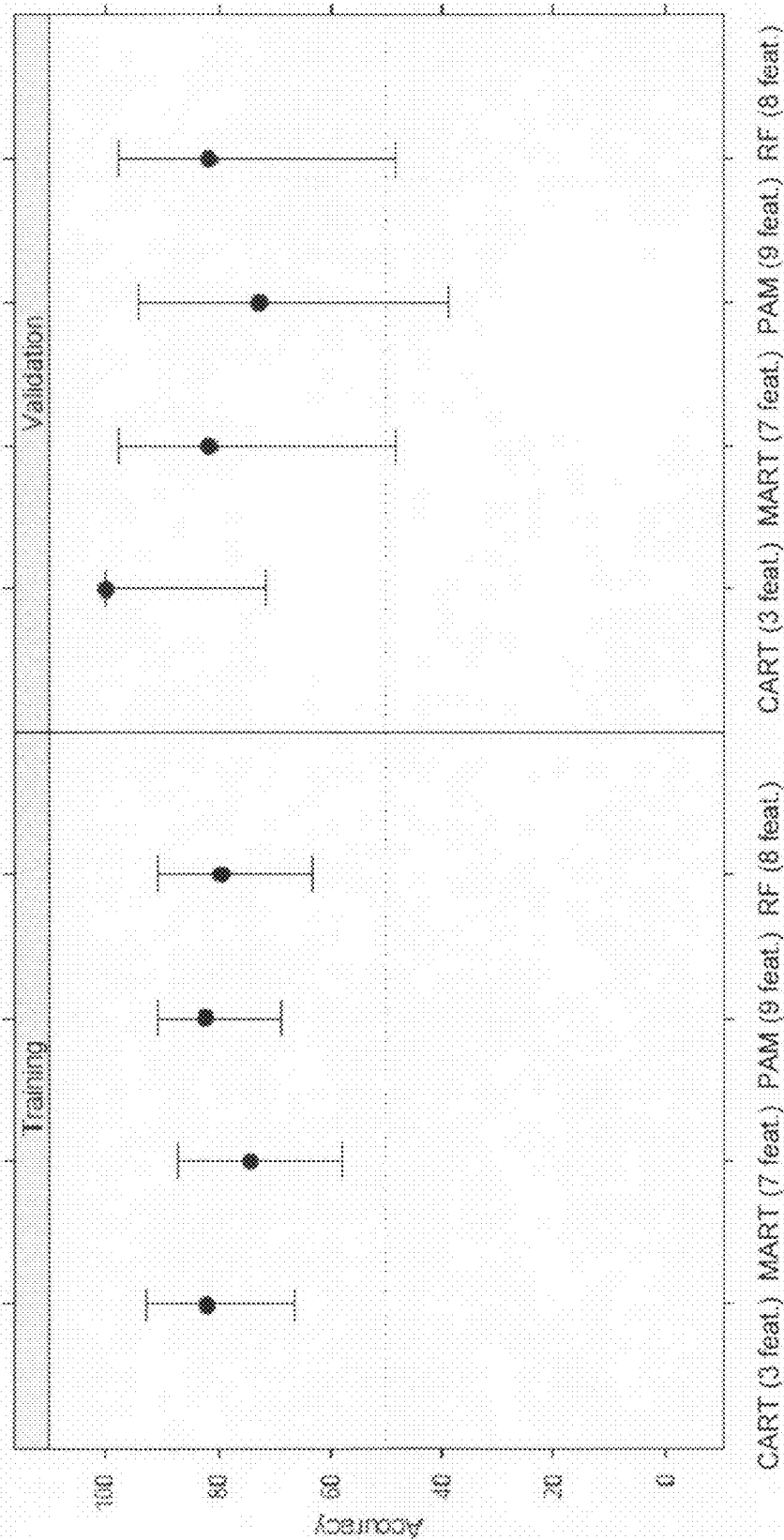

FIG. 47

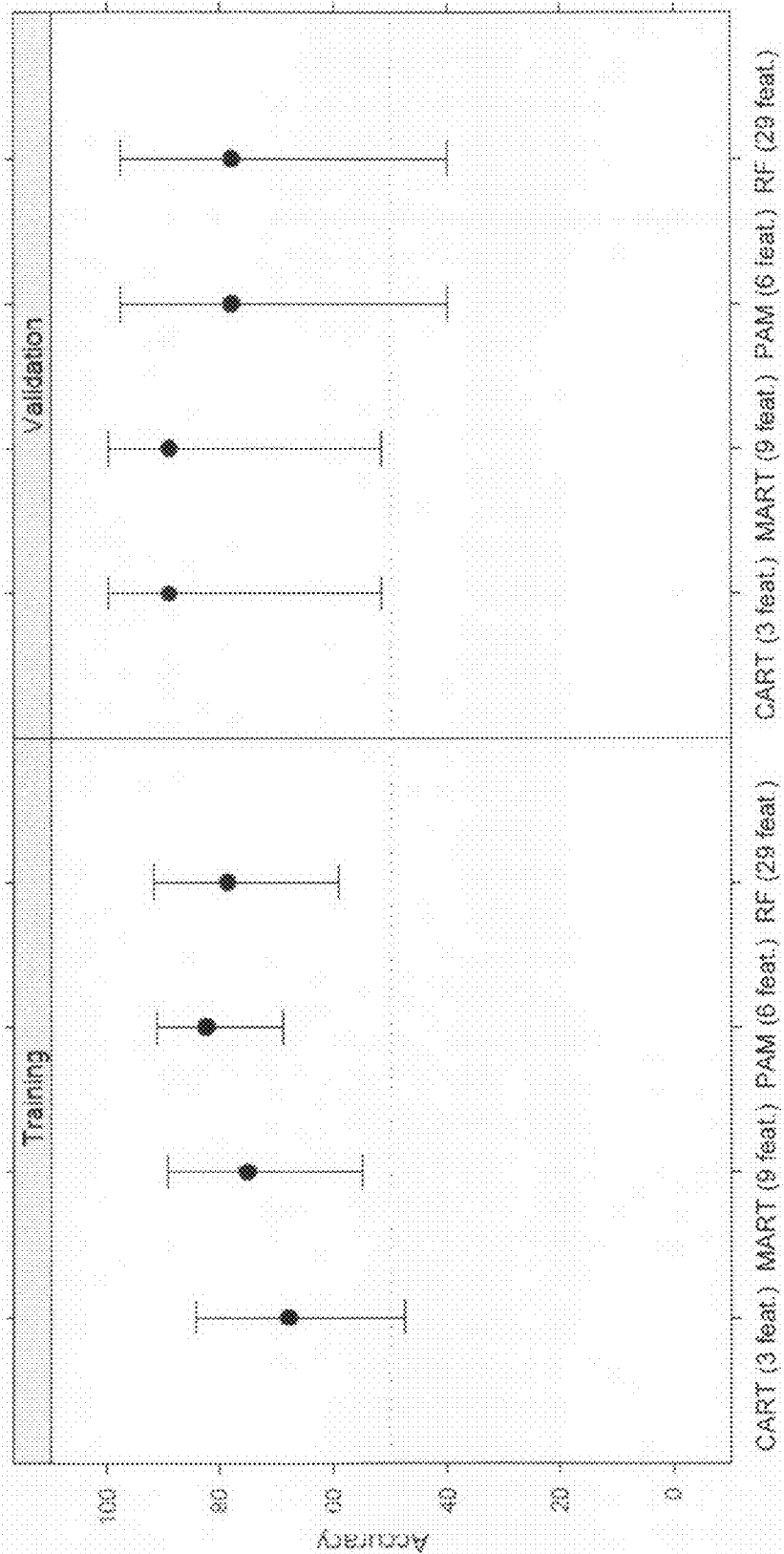

FIG. 48

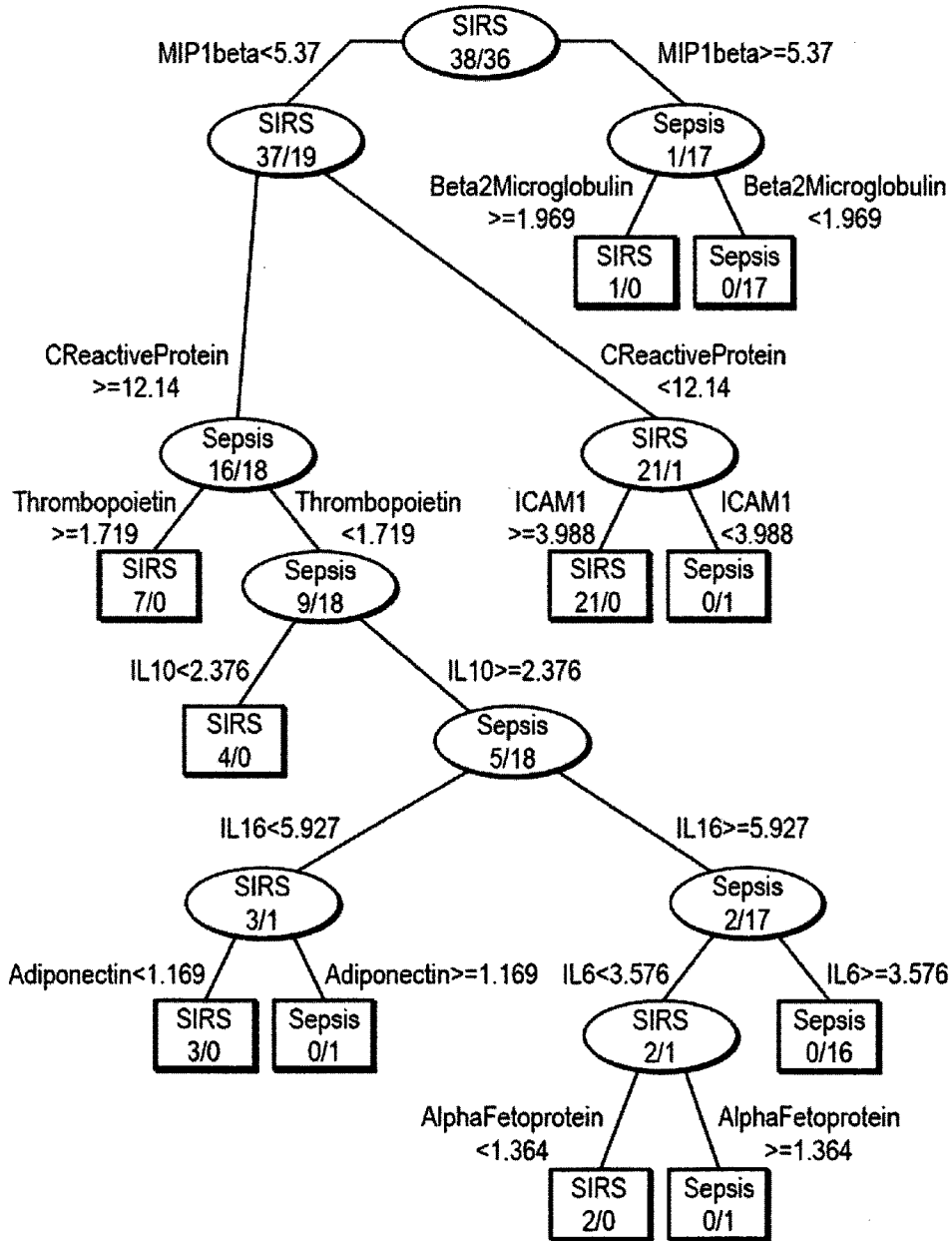

FIG. 49

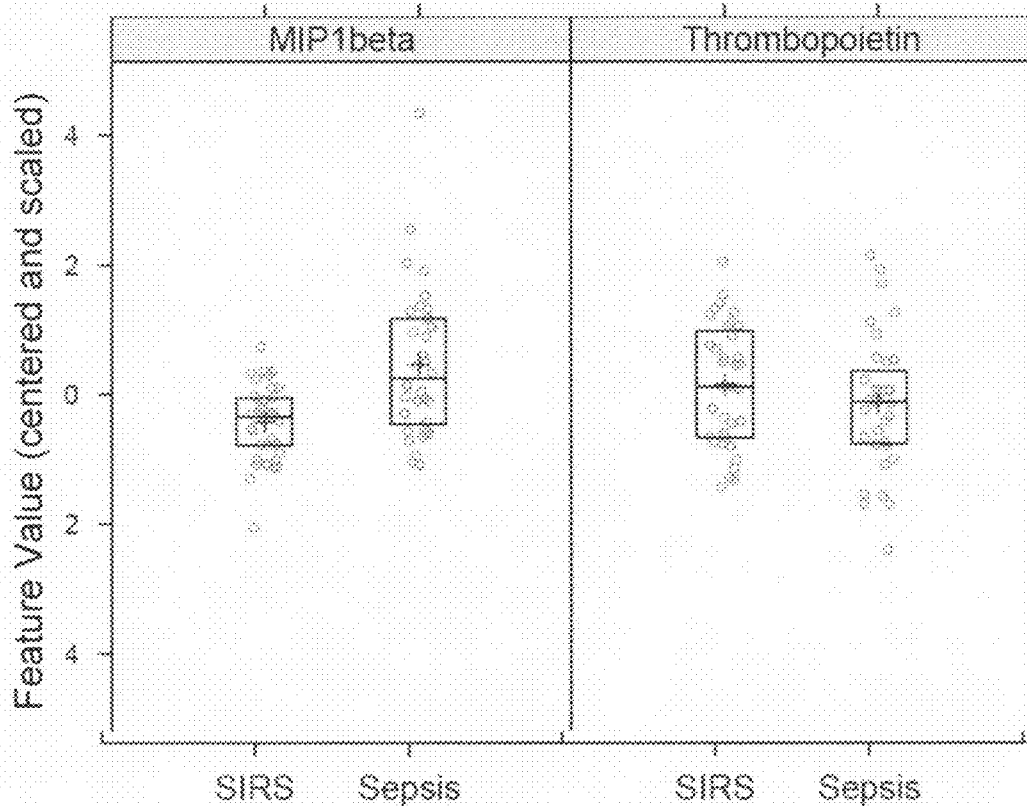

FIG. 50A

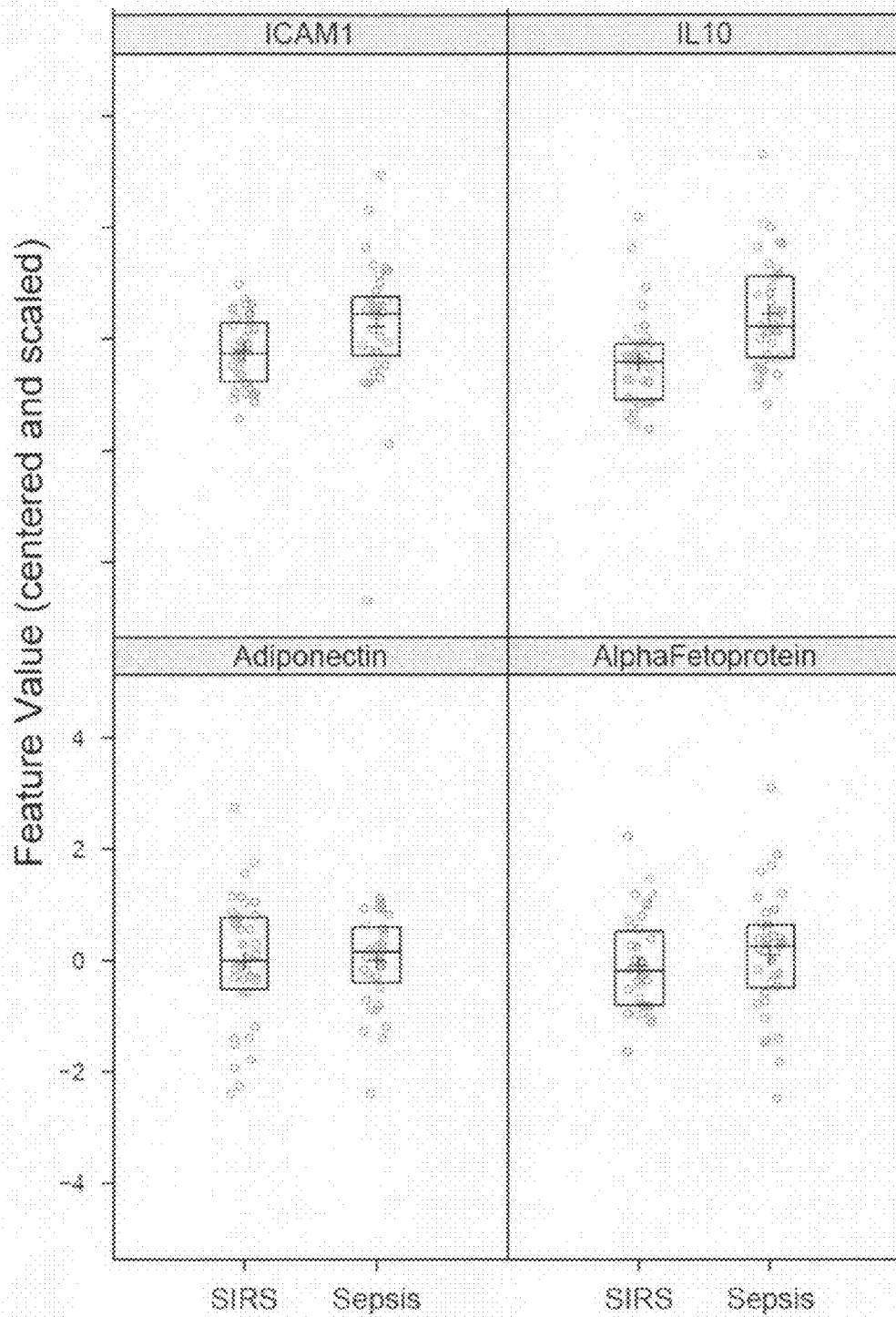

FIG. 50B

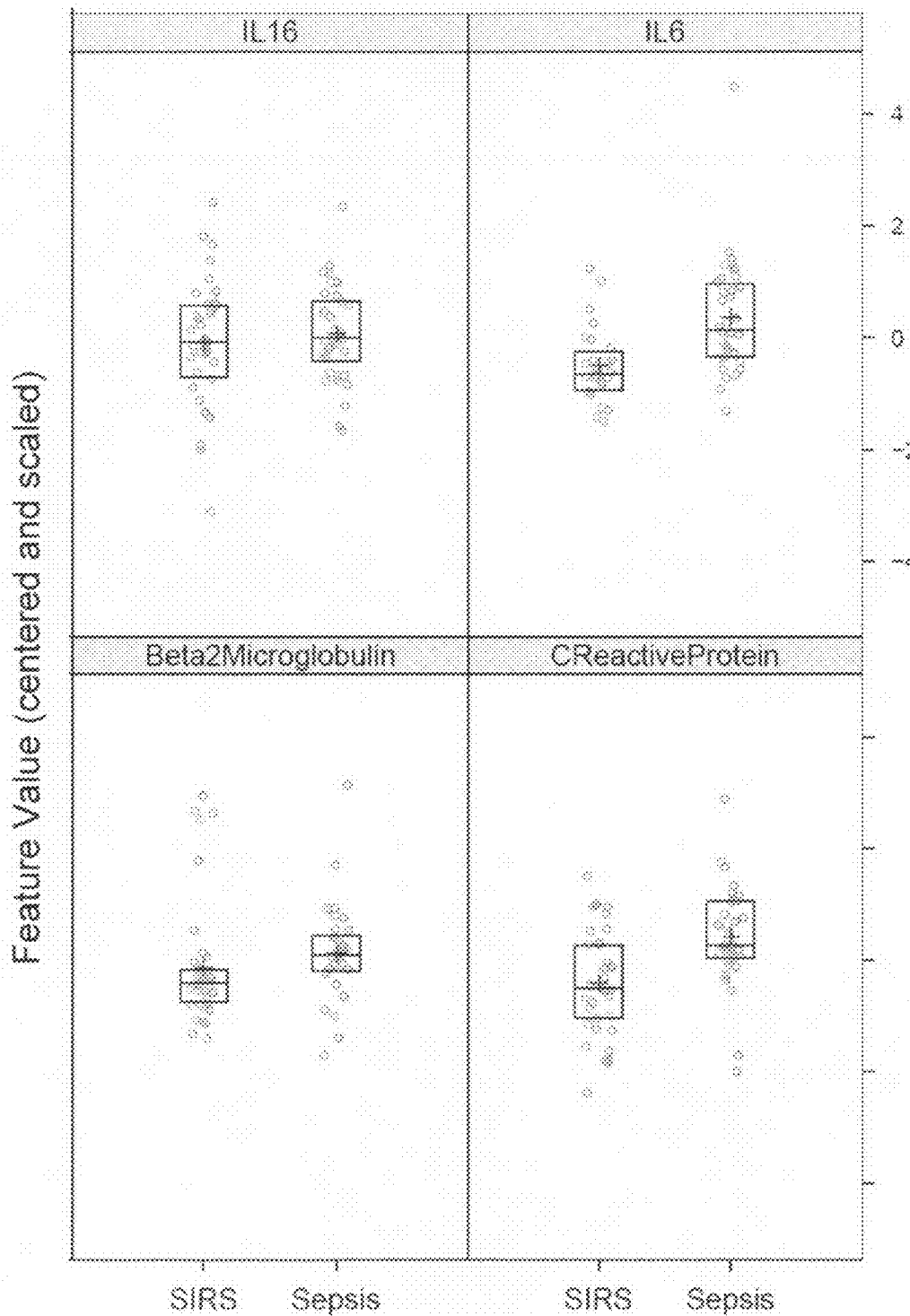

FIG. 50C

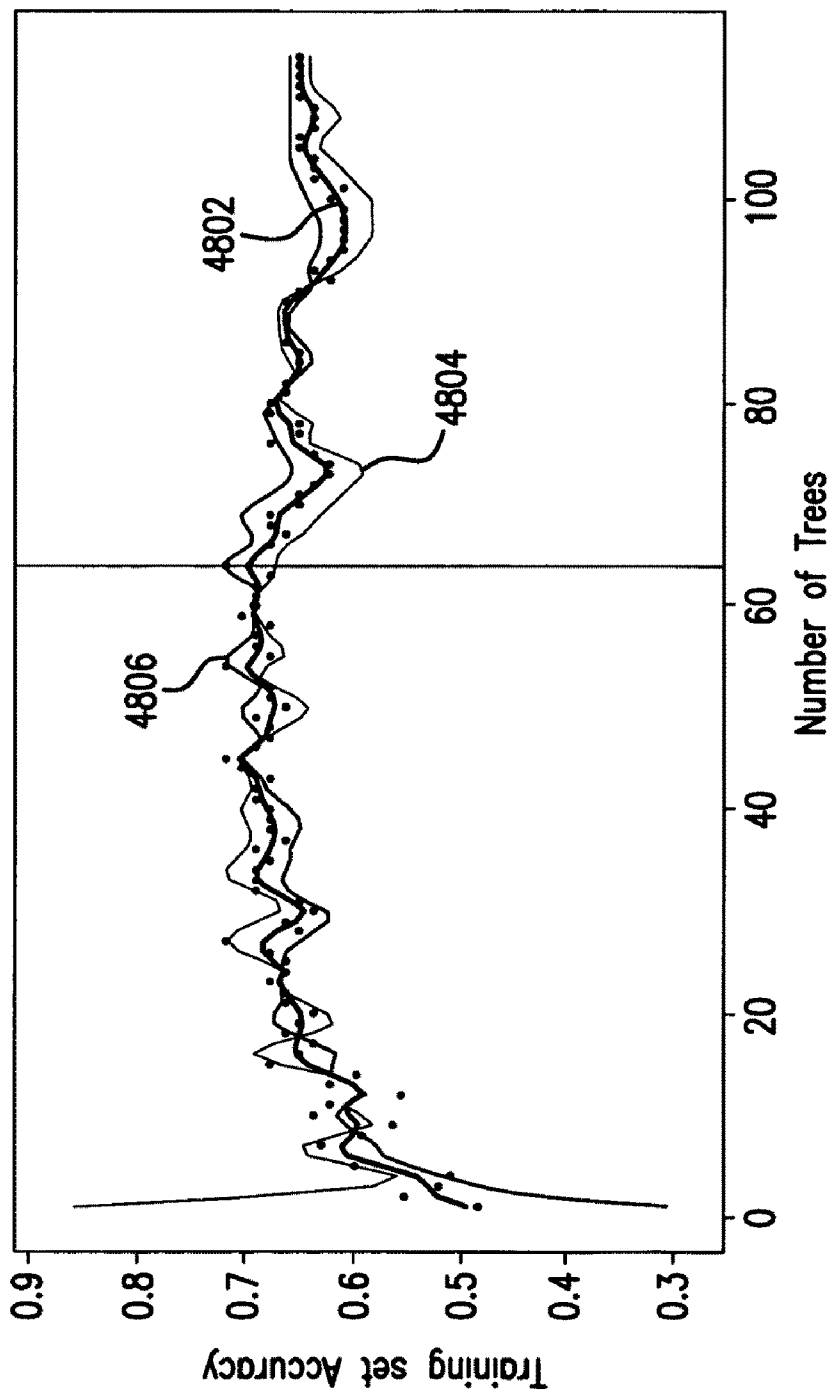

FIG. 51

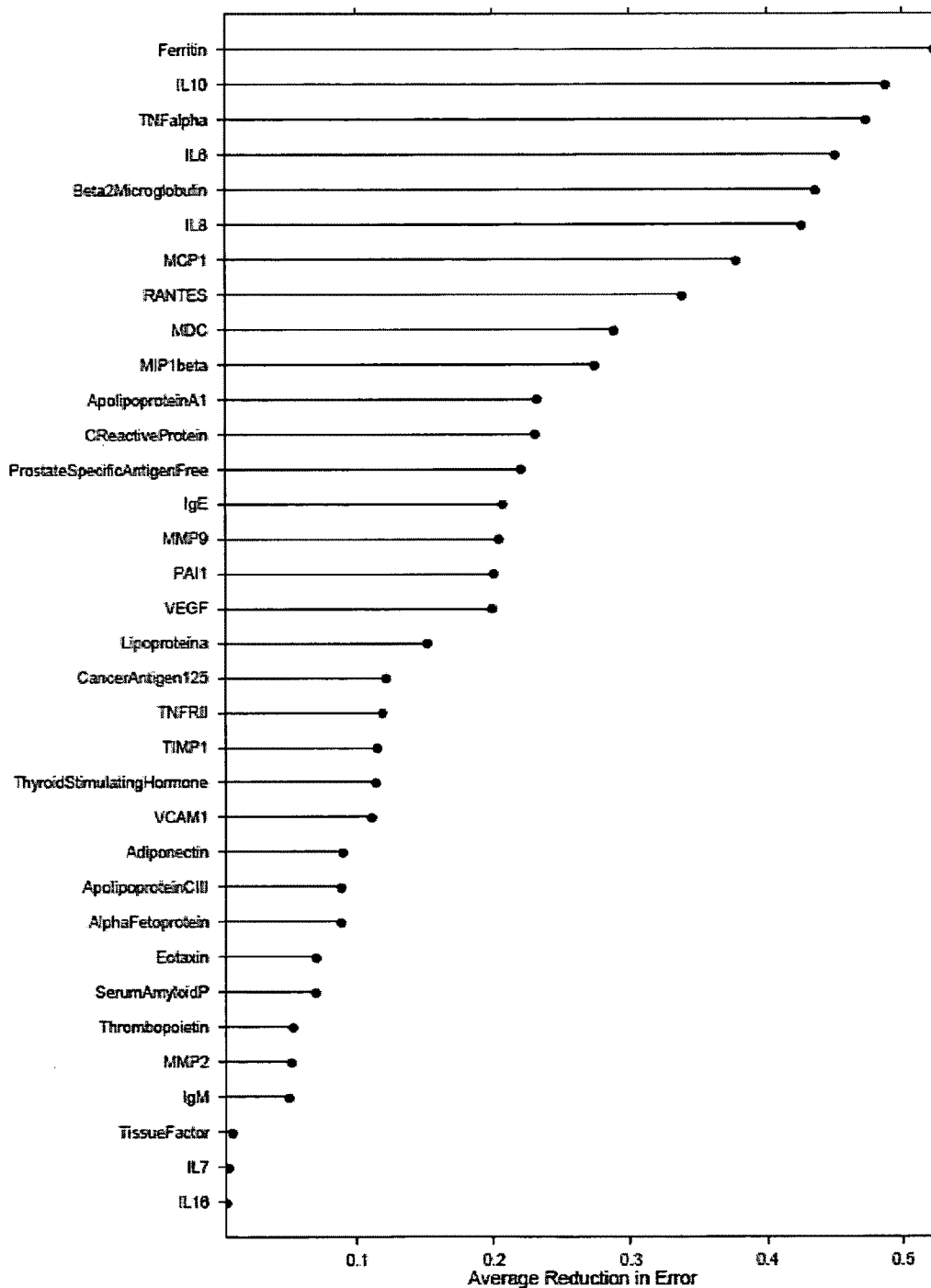

FIG. 52

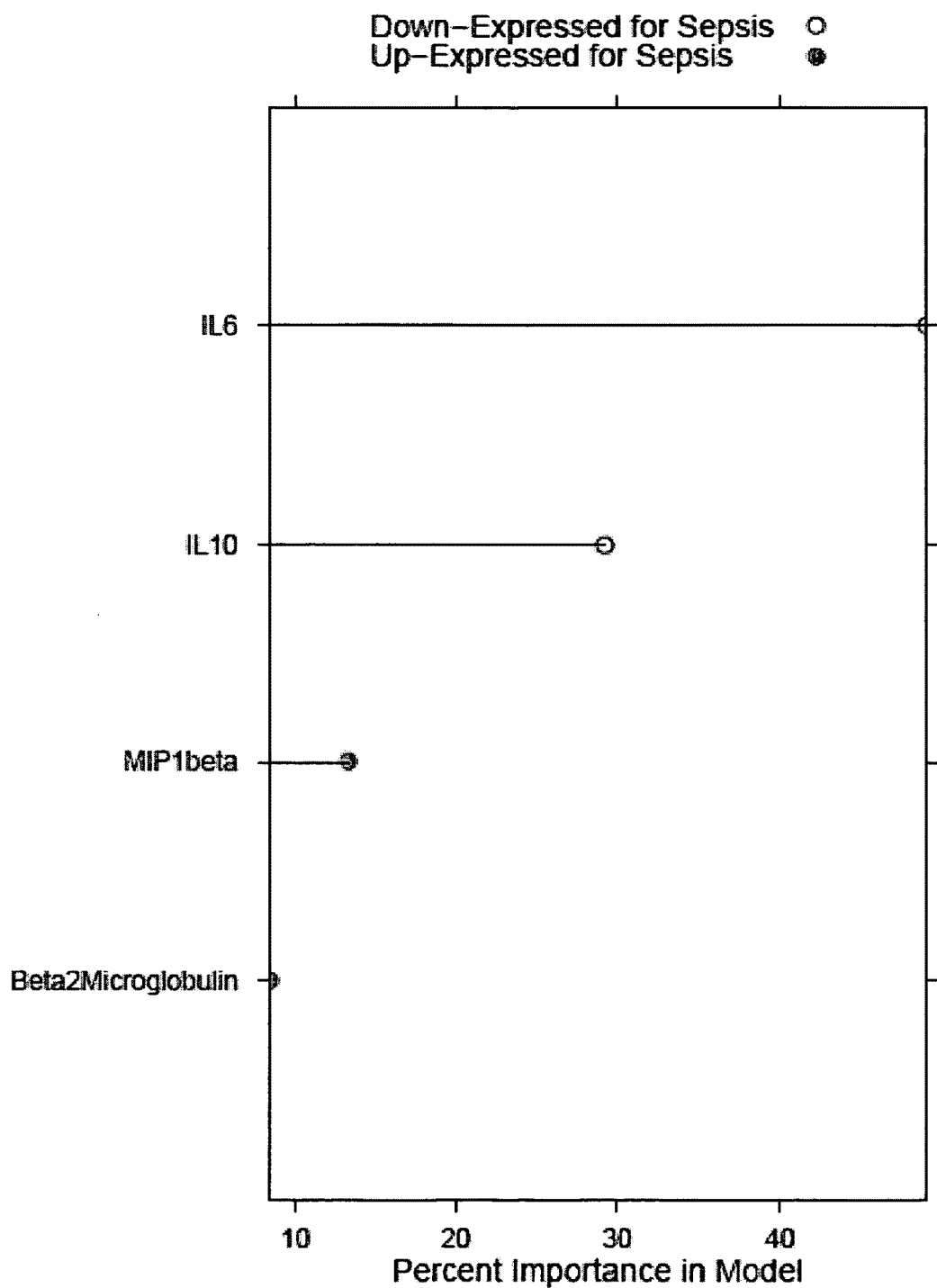

FIG. 53

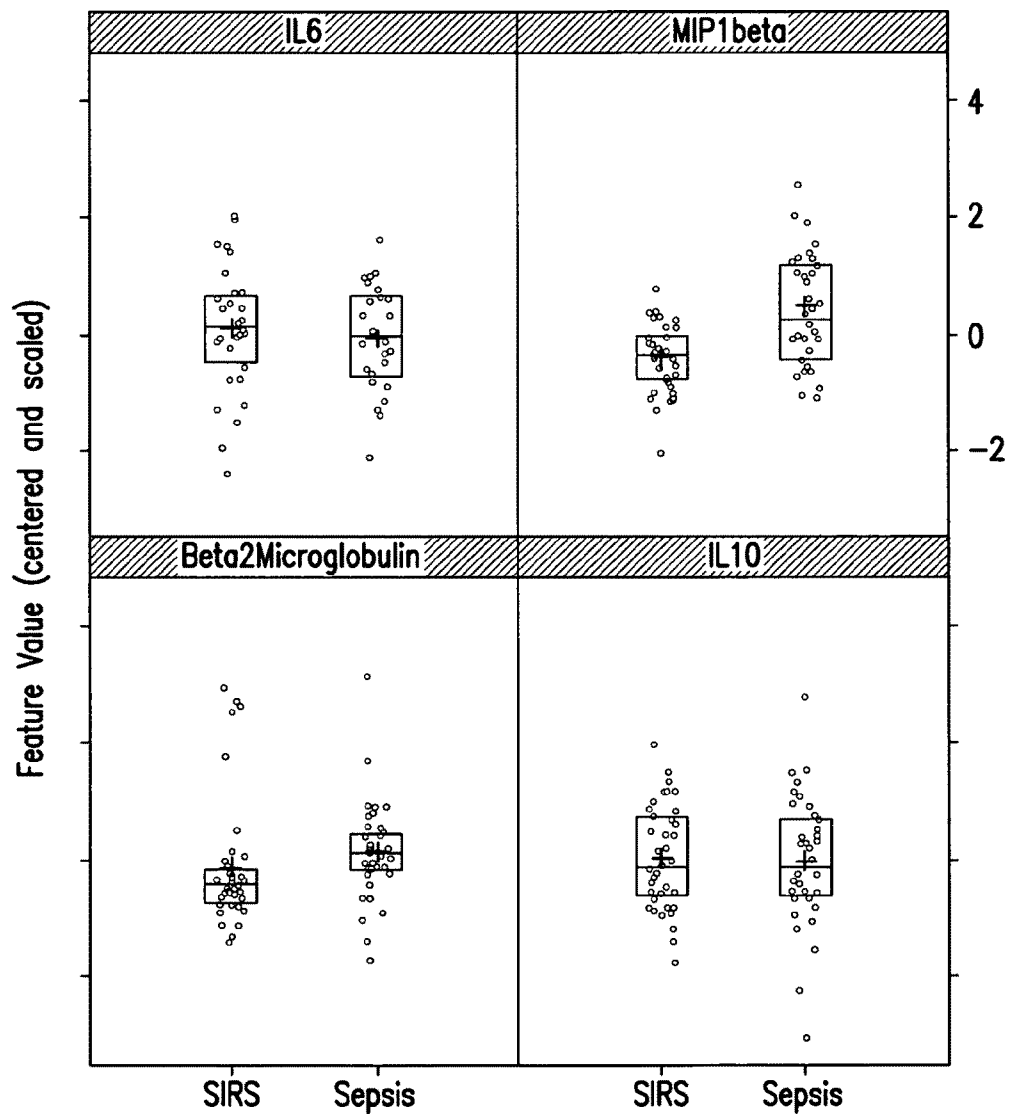

FIG.54

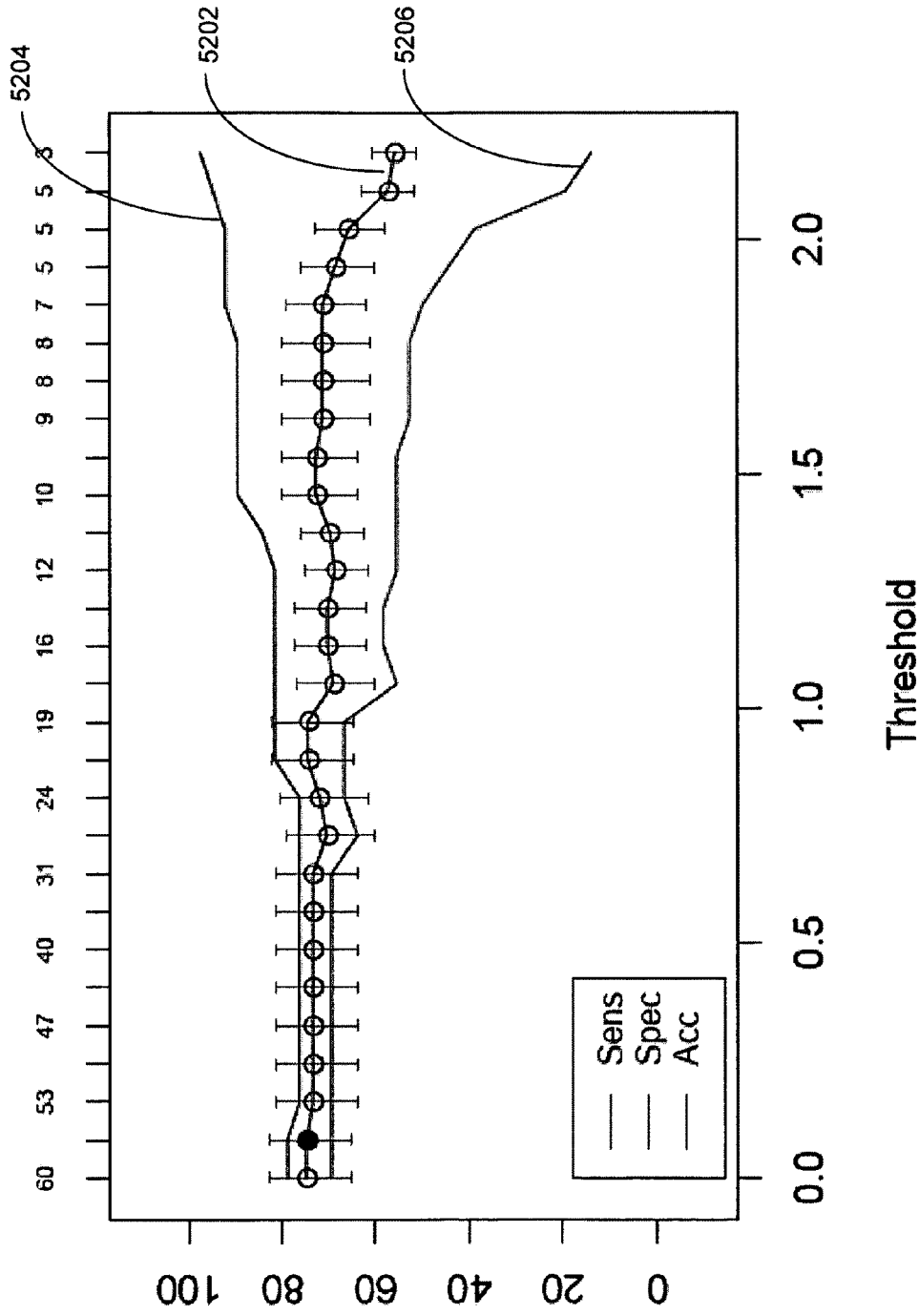

FIG. 55

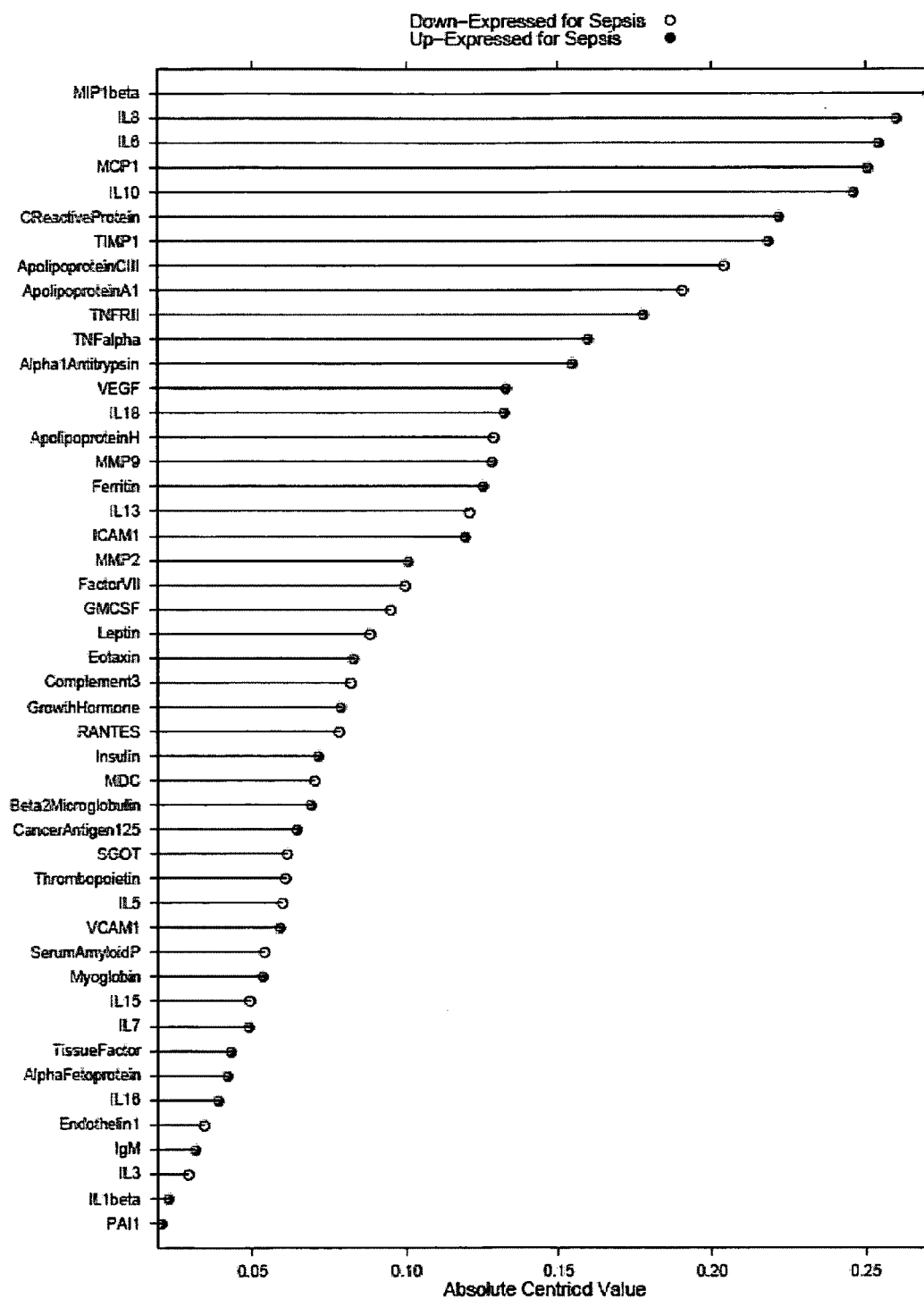

FIG. 56

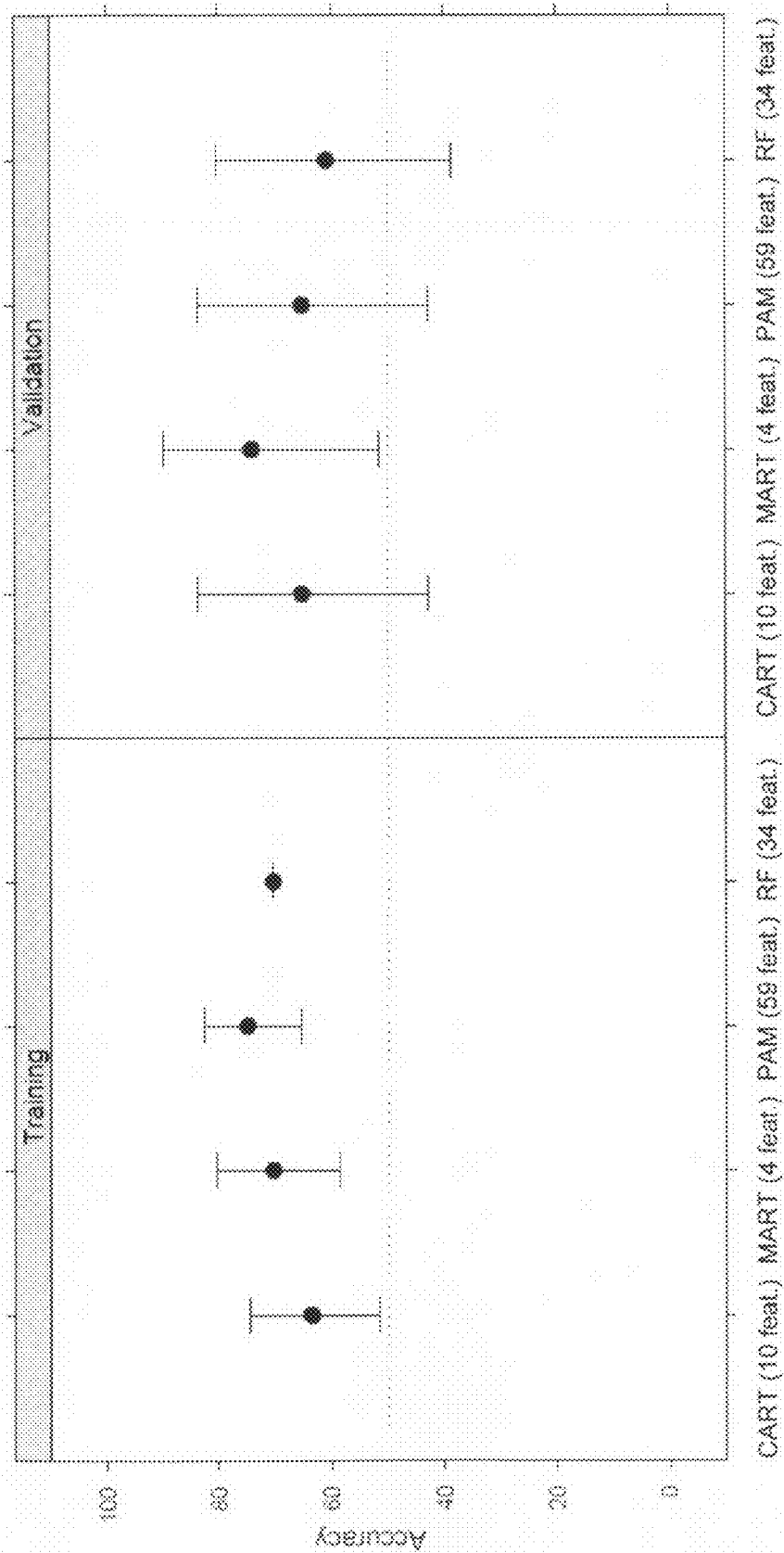

FIG. 57

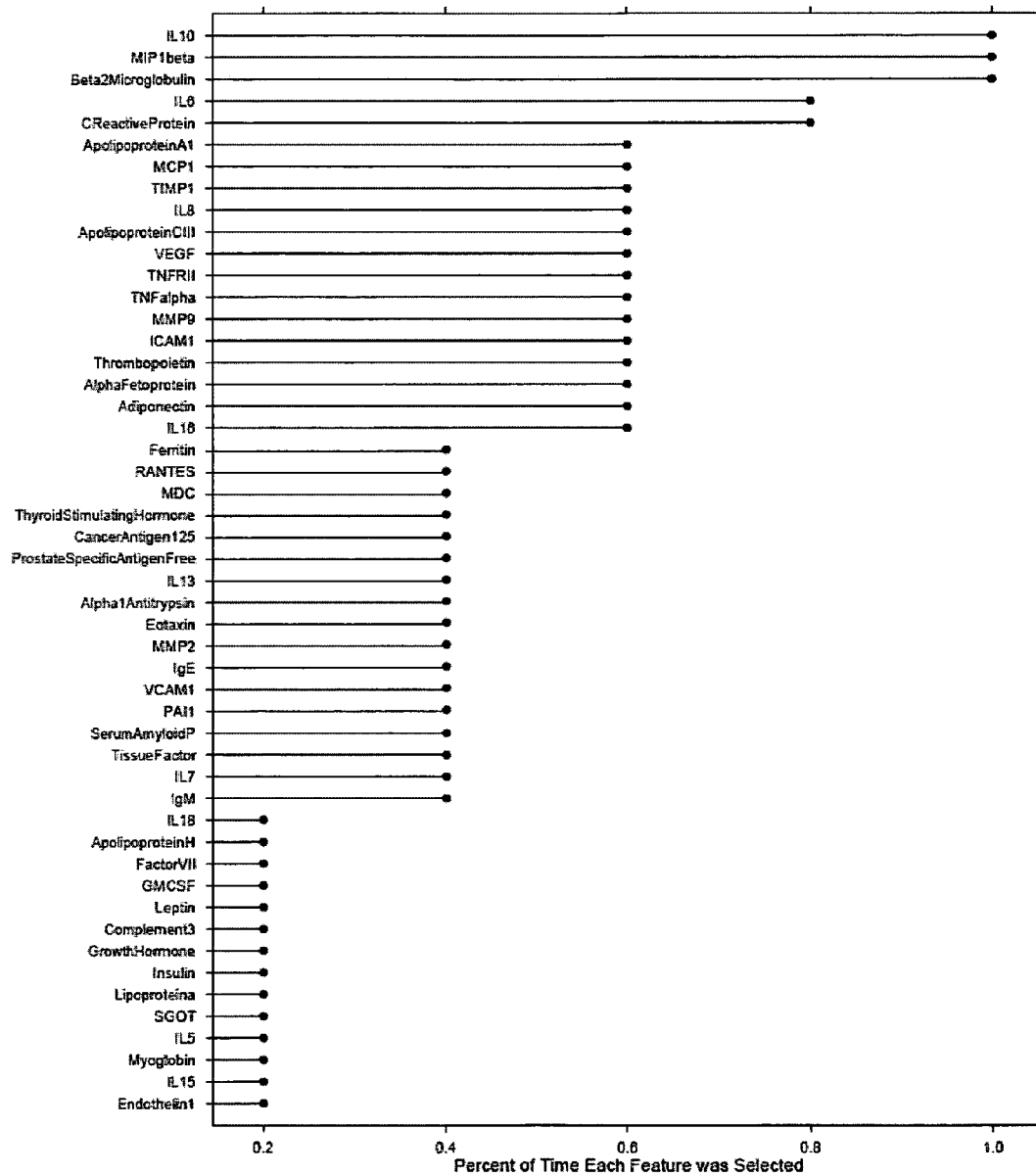

FIG. 58

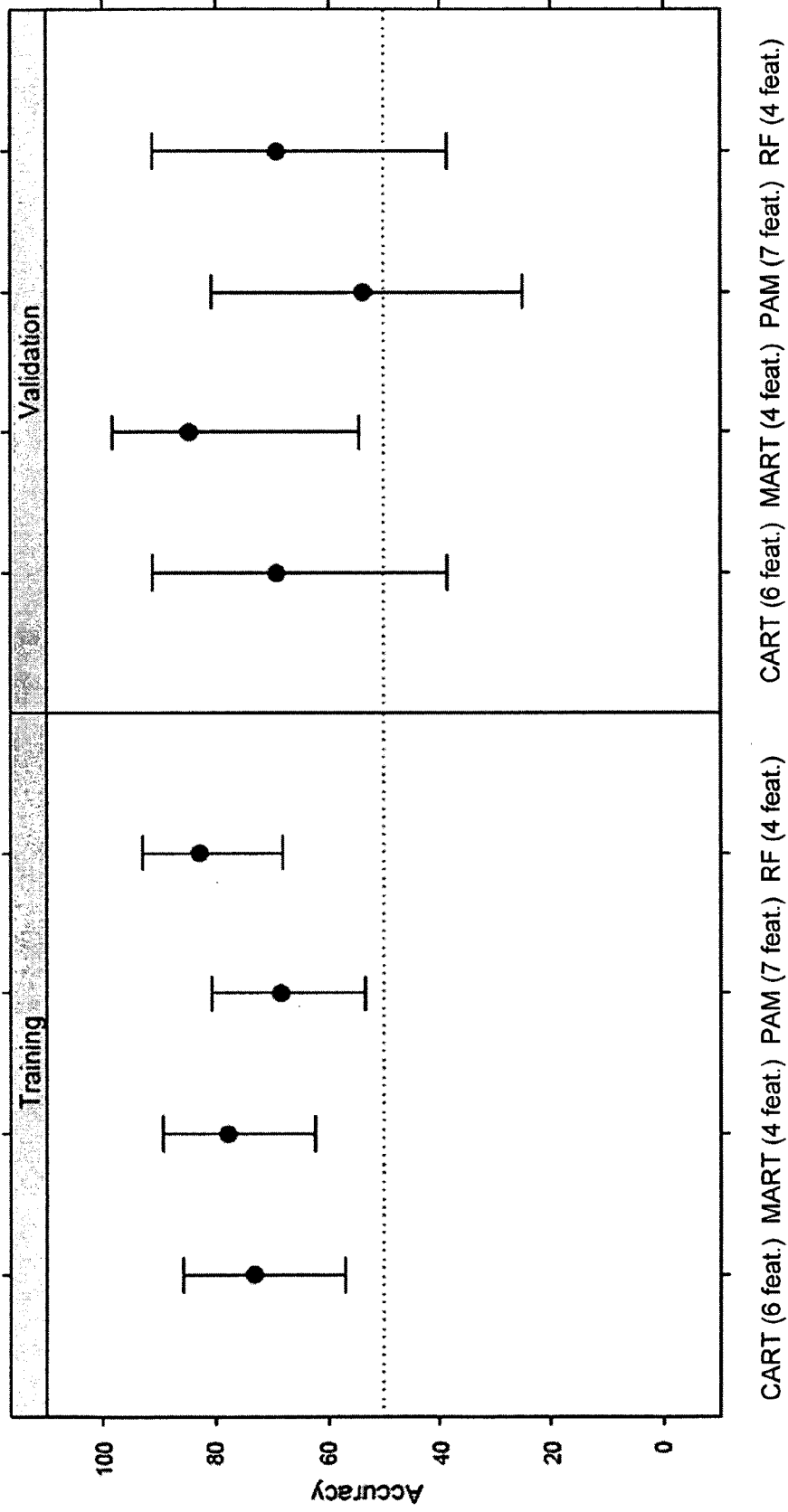
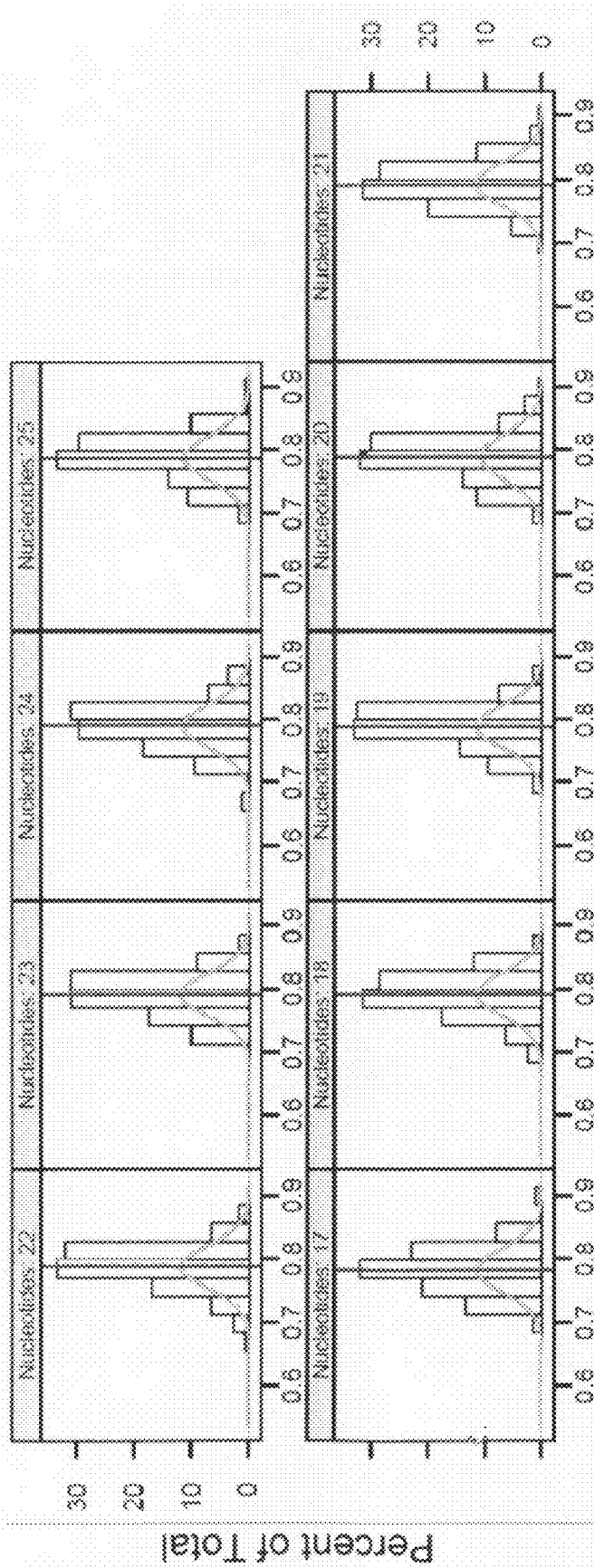

FIG. 59



Accuracy

FIG. 60A

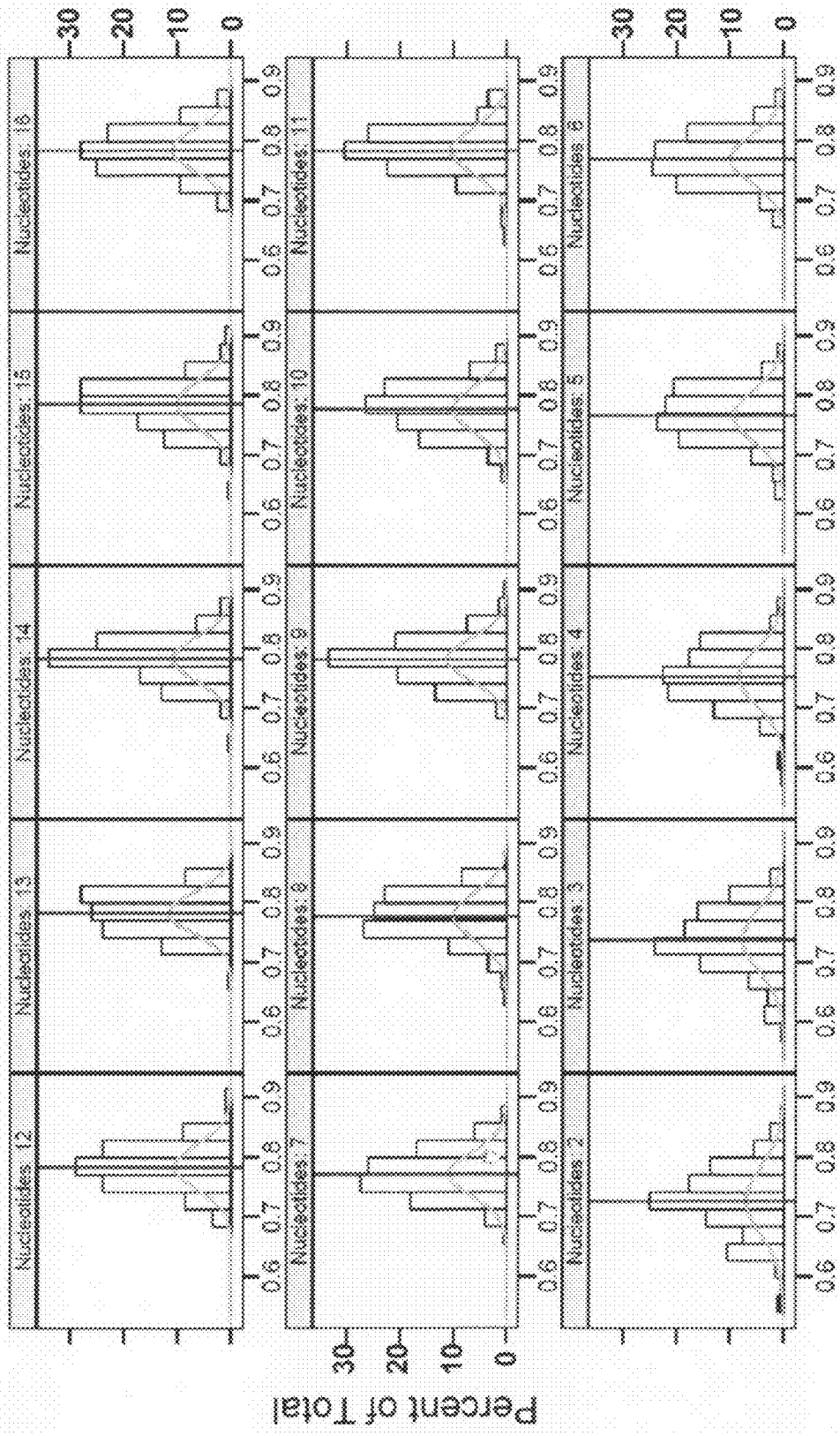

FIG. 60B Accuracy

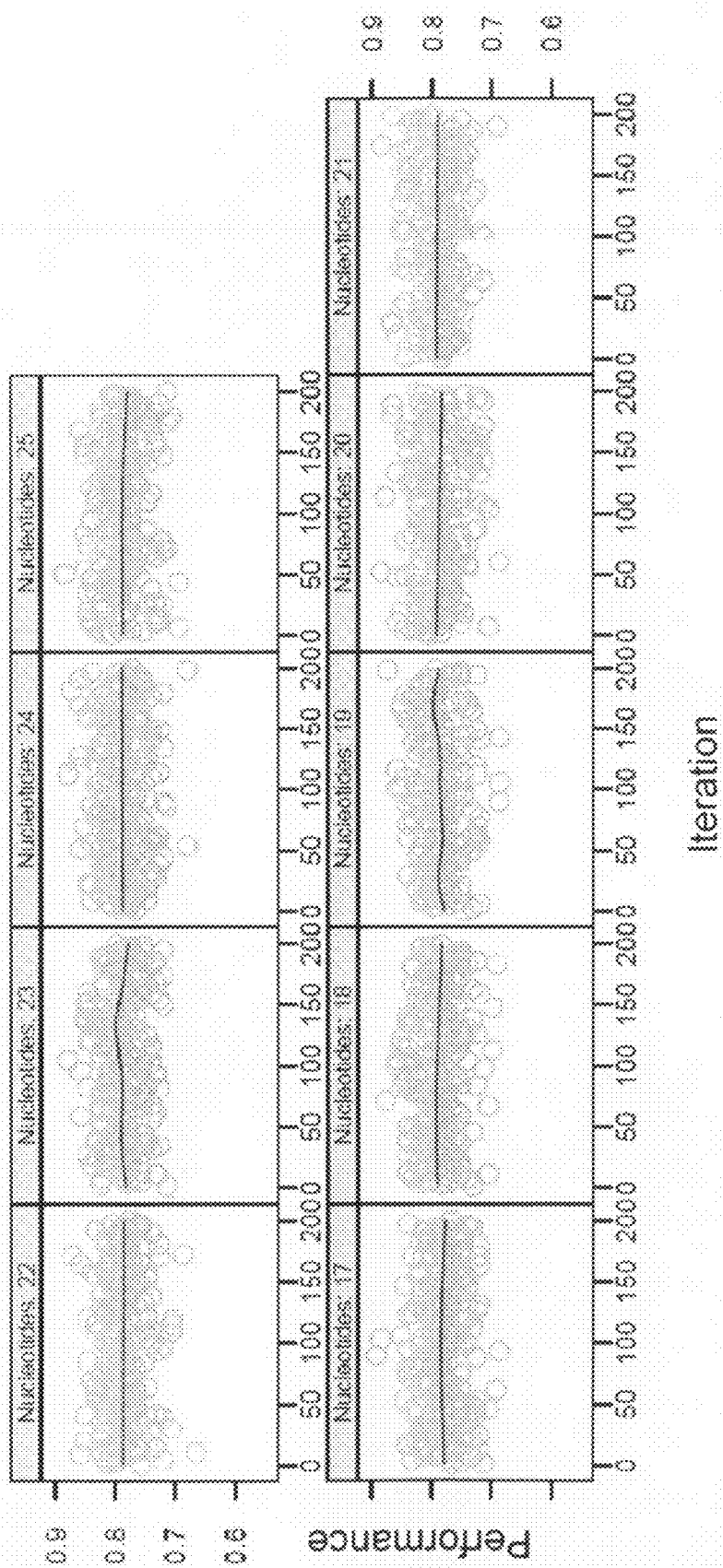

FIG. 61A

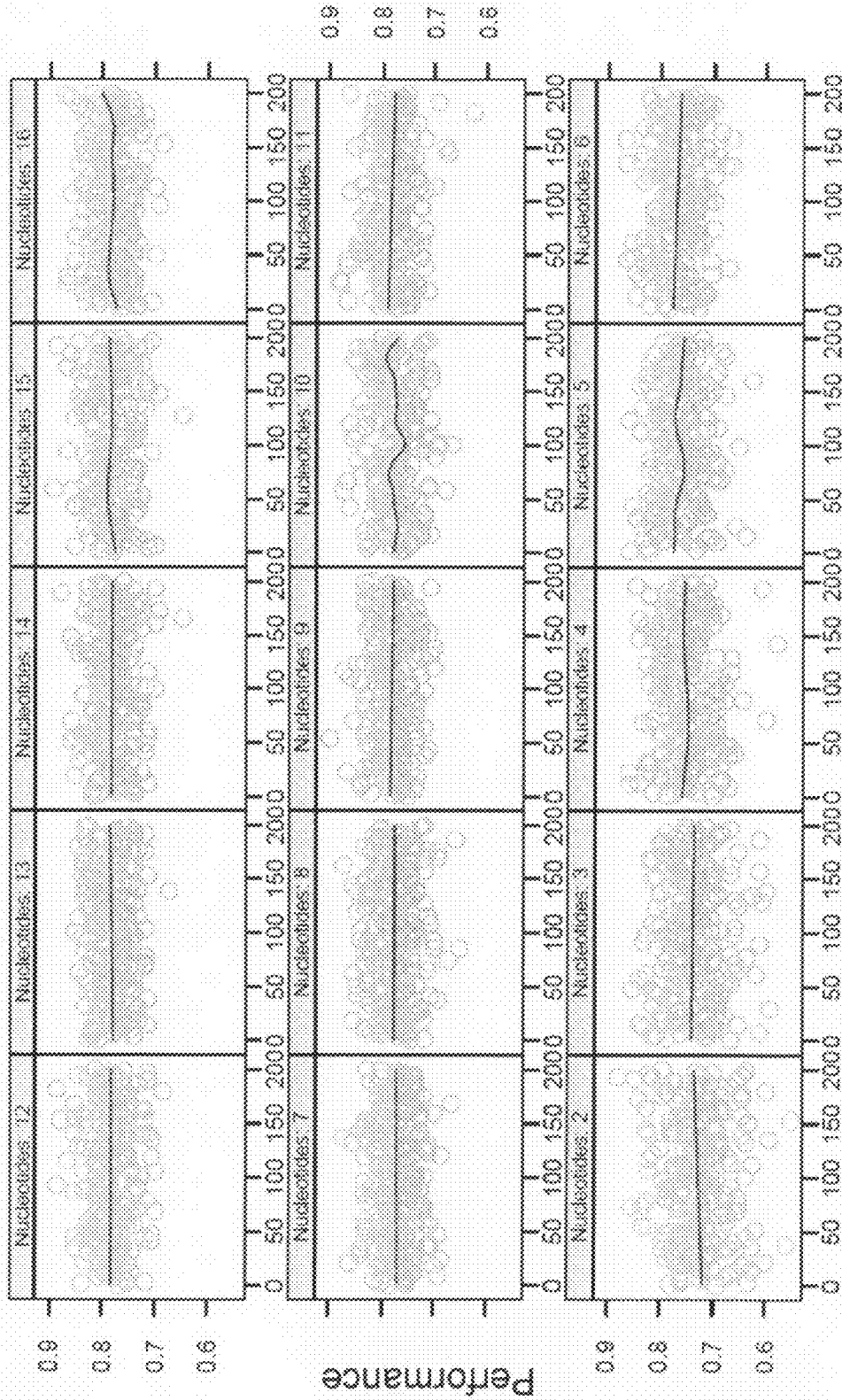
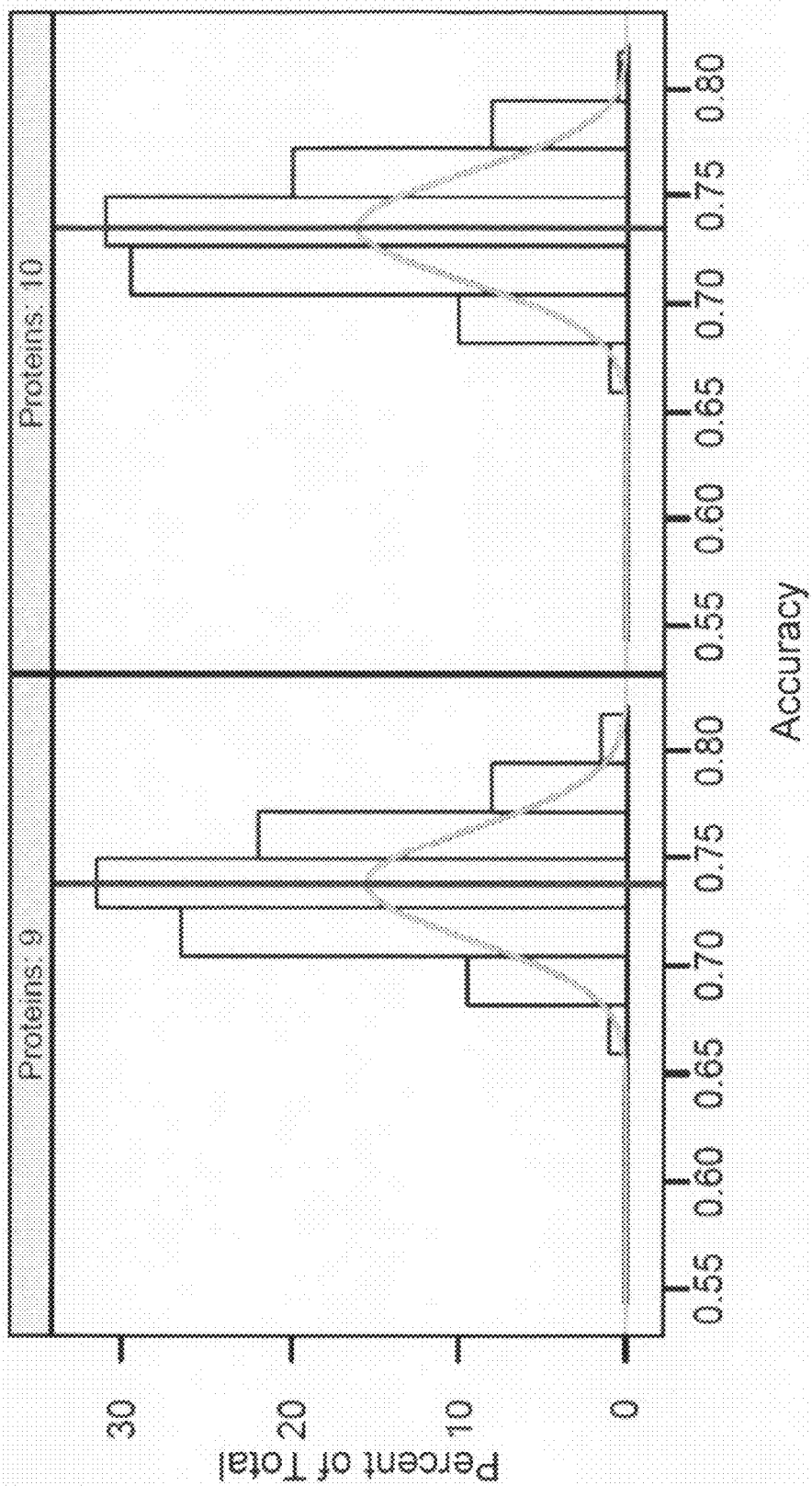

FIG. 61B Iteration



Accuracy

FIG. 62A

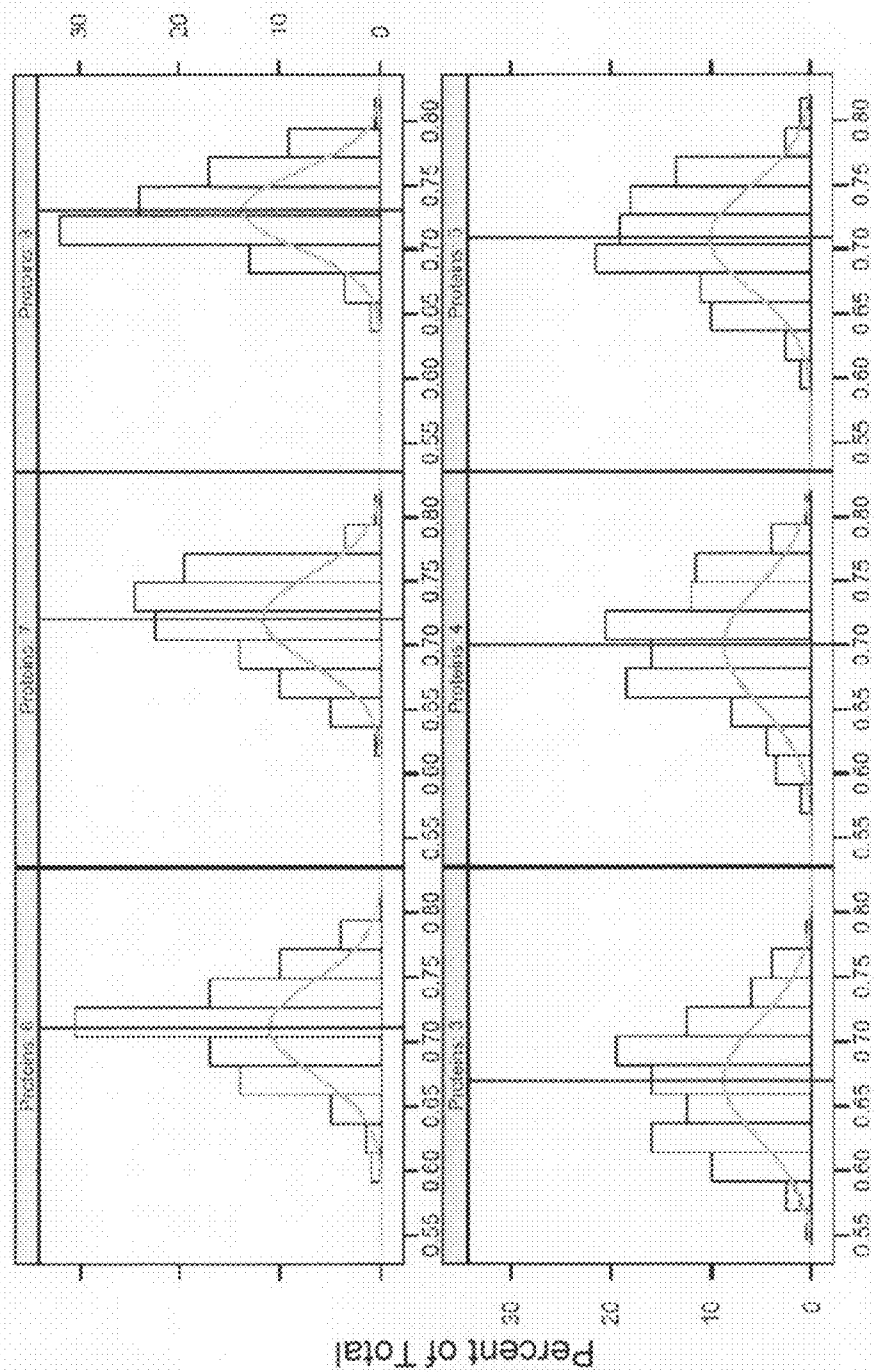

FIG. 62B Accuracy

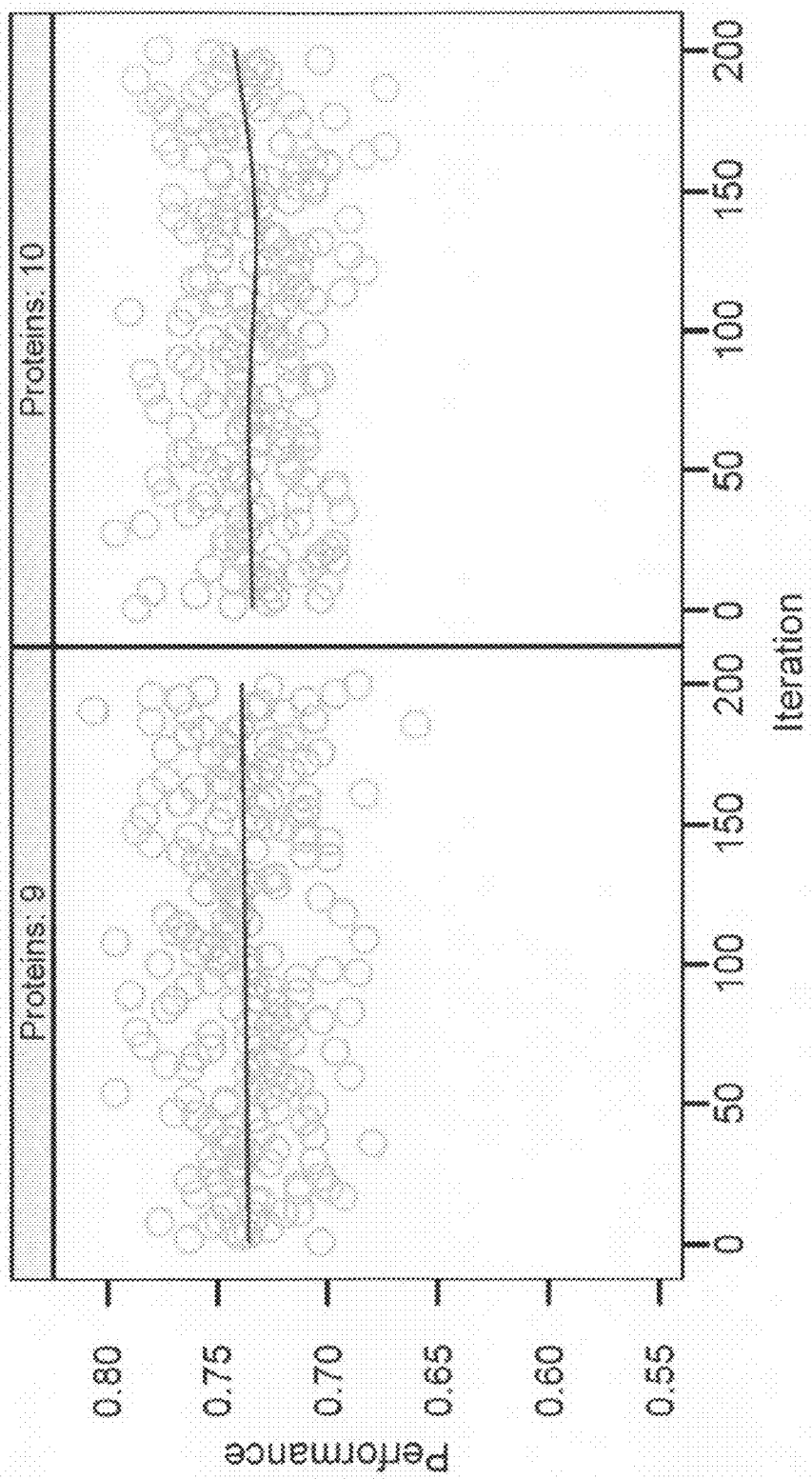

FIG. 63A

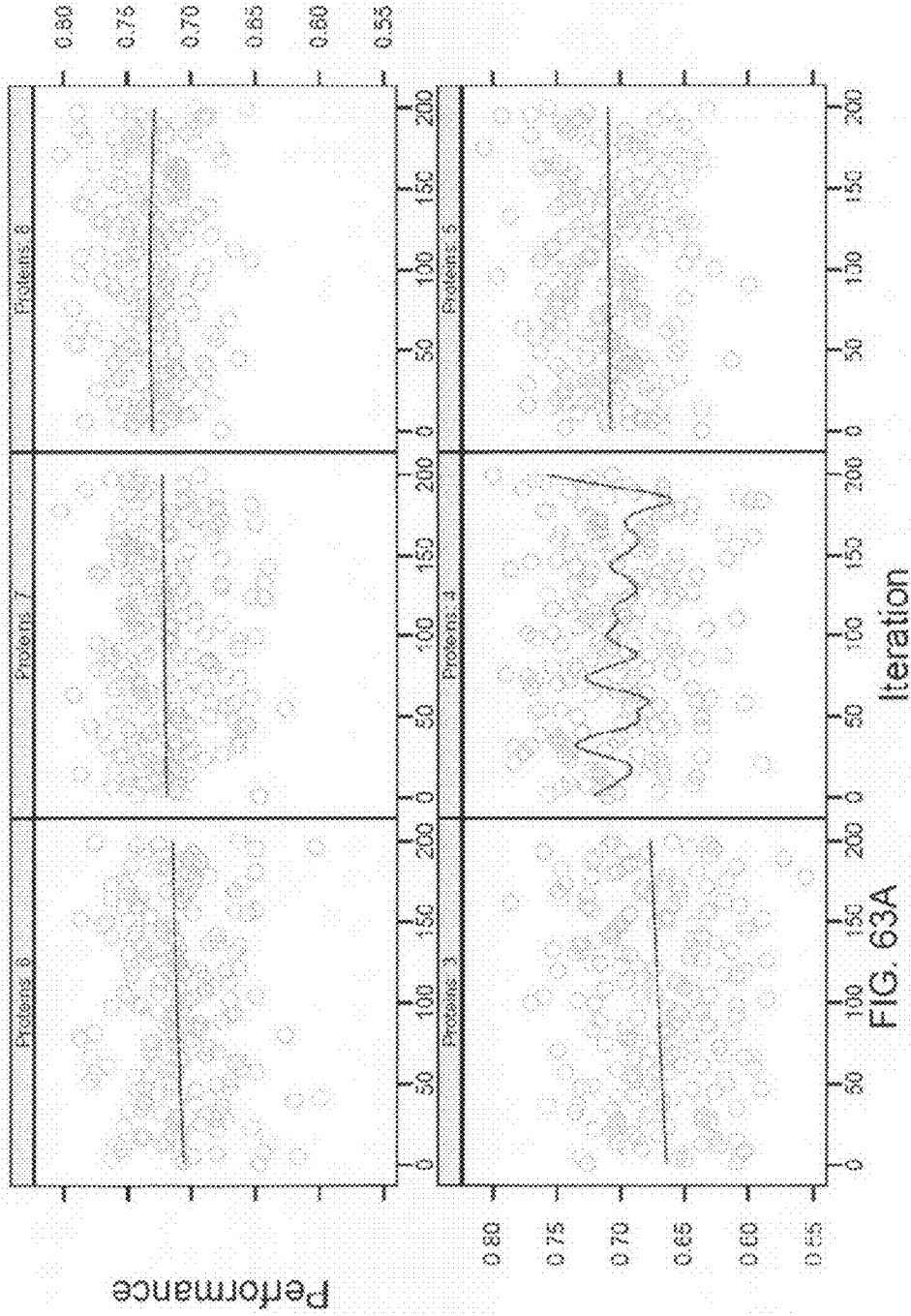

FIG. 63A
Continued

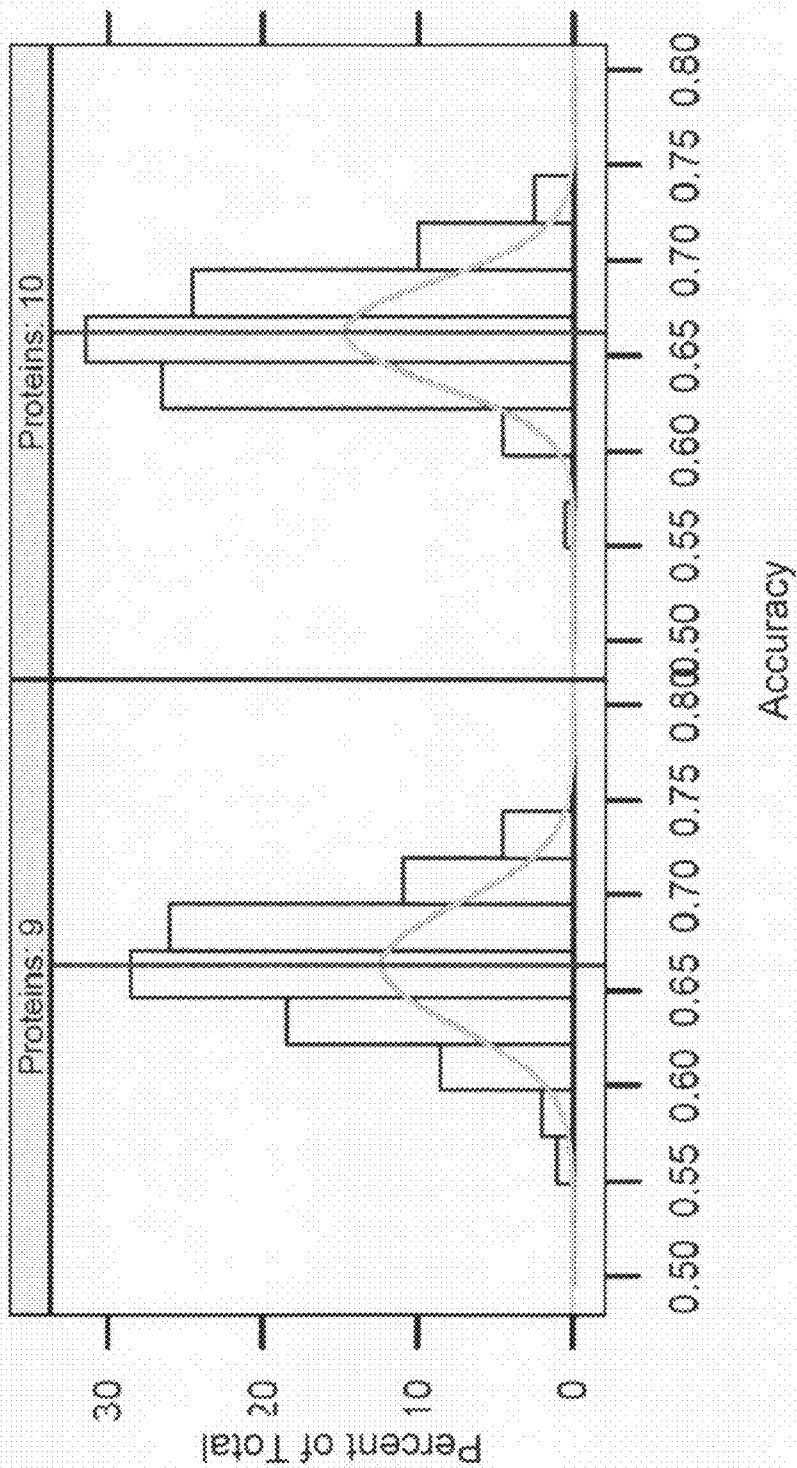

FIG. 64A

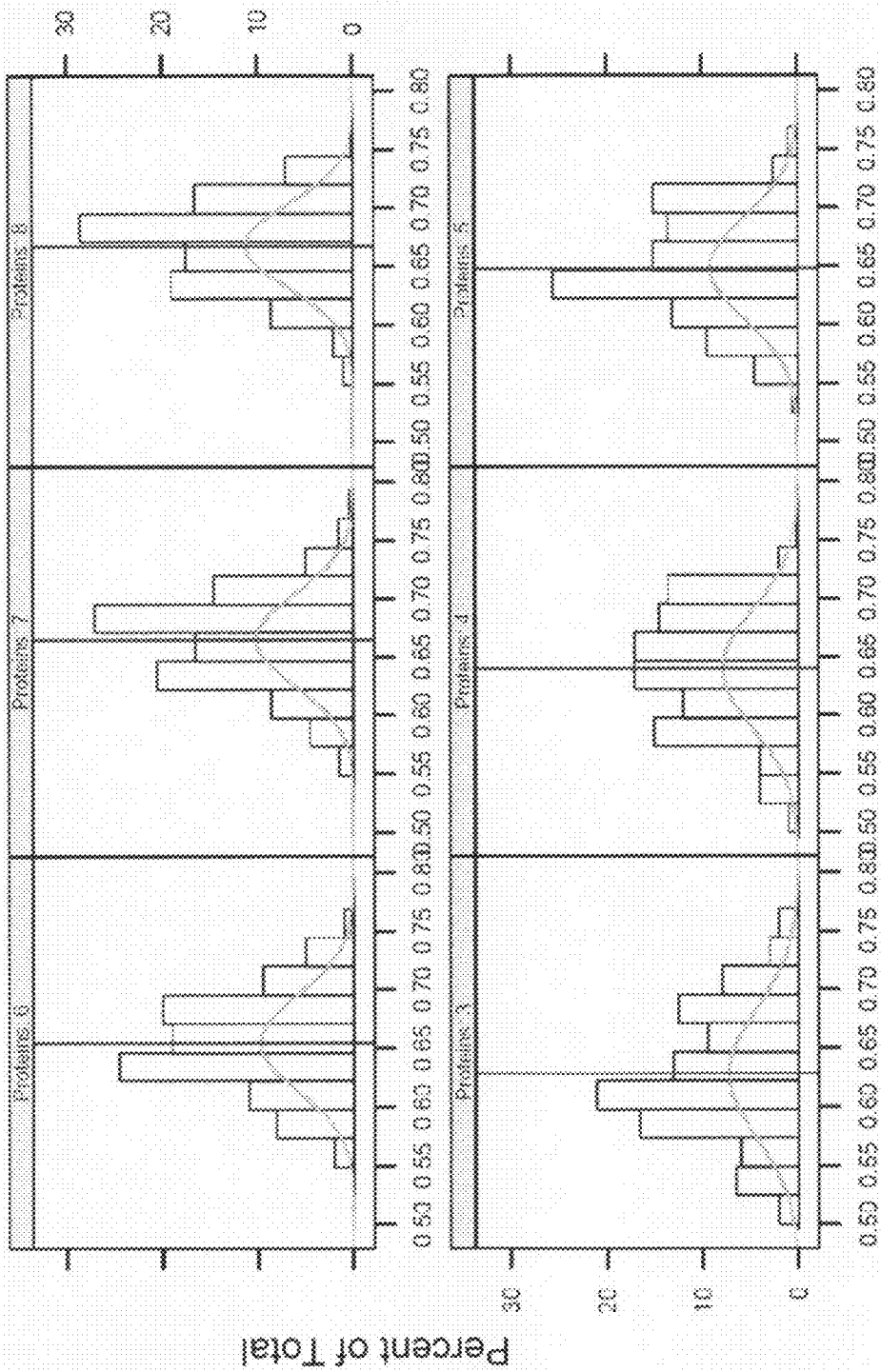

FIG. 64B Accuracy

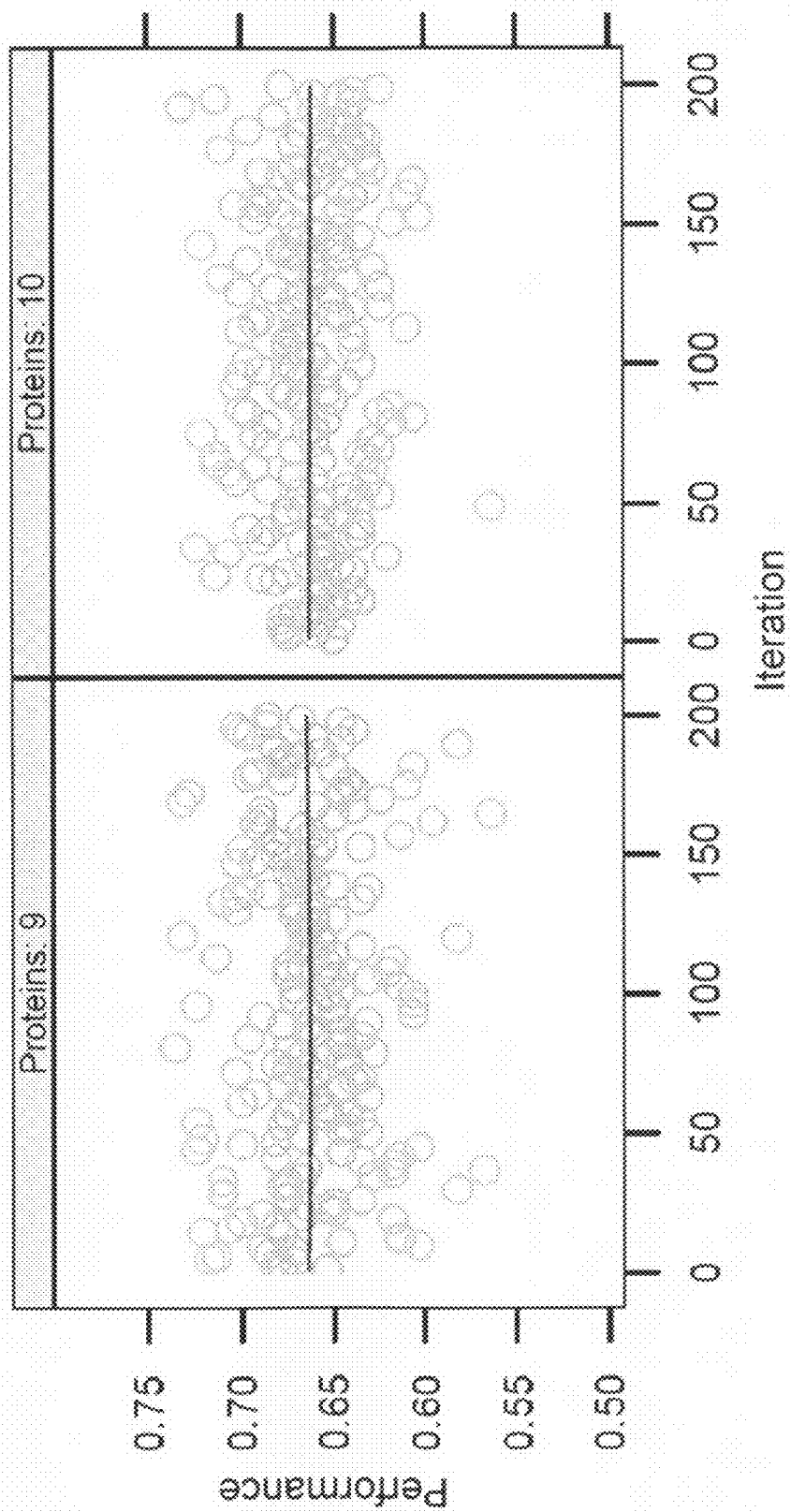

FIG. 65A

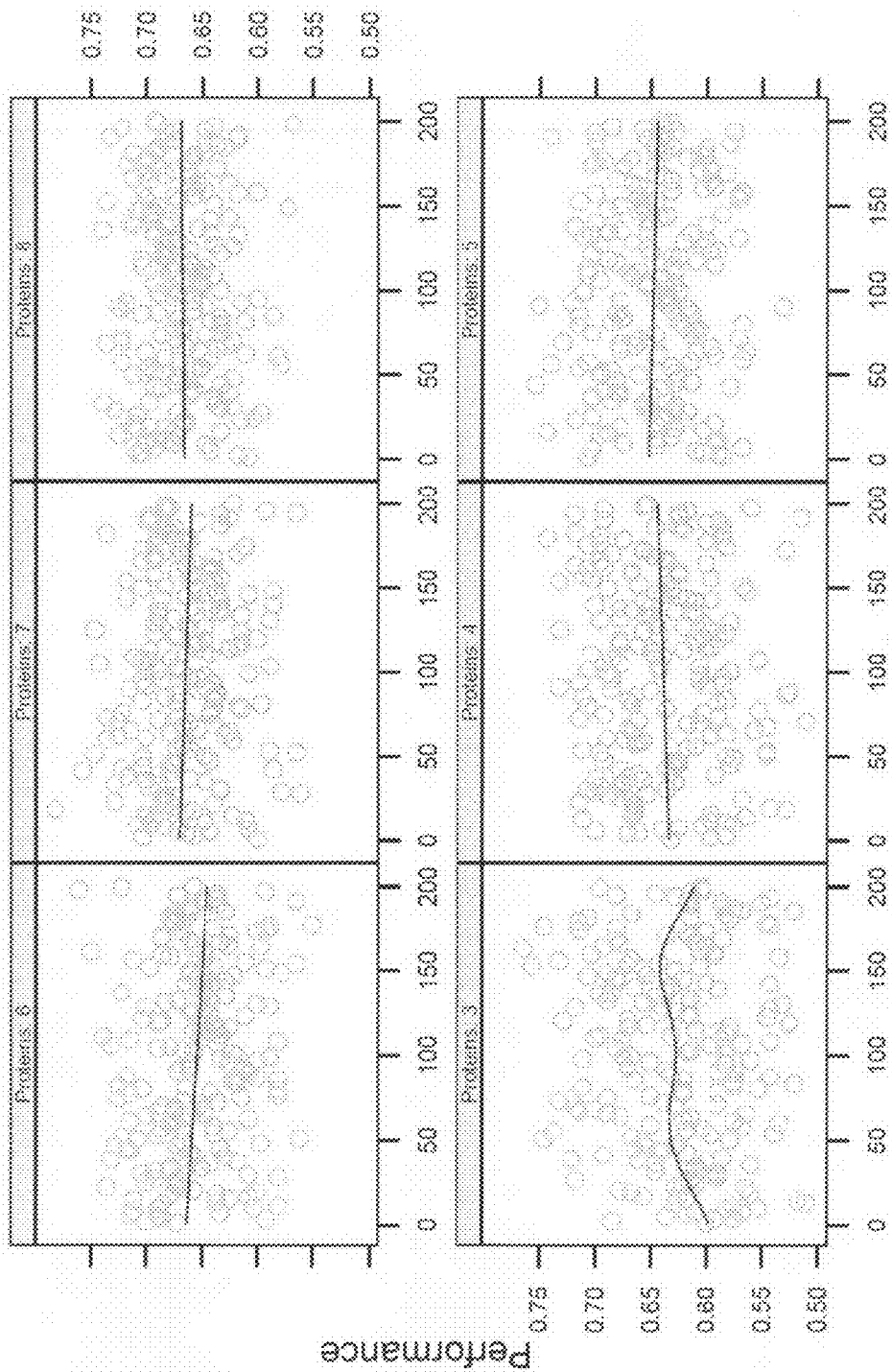

FIG. 65B Iteration

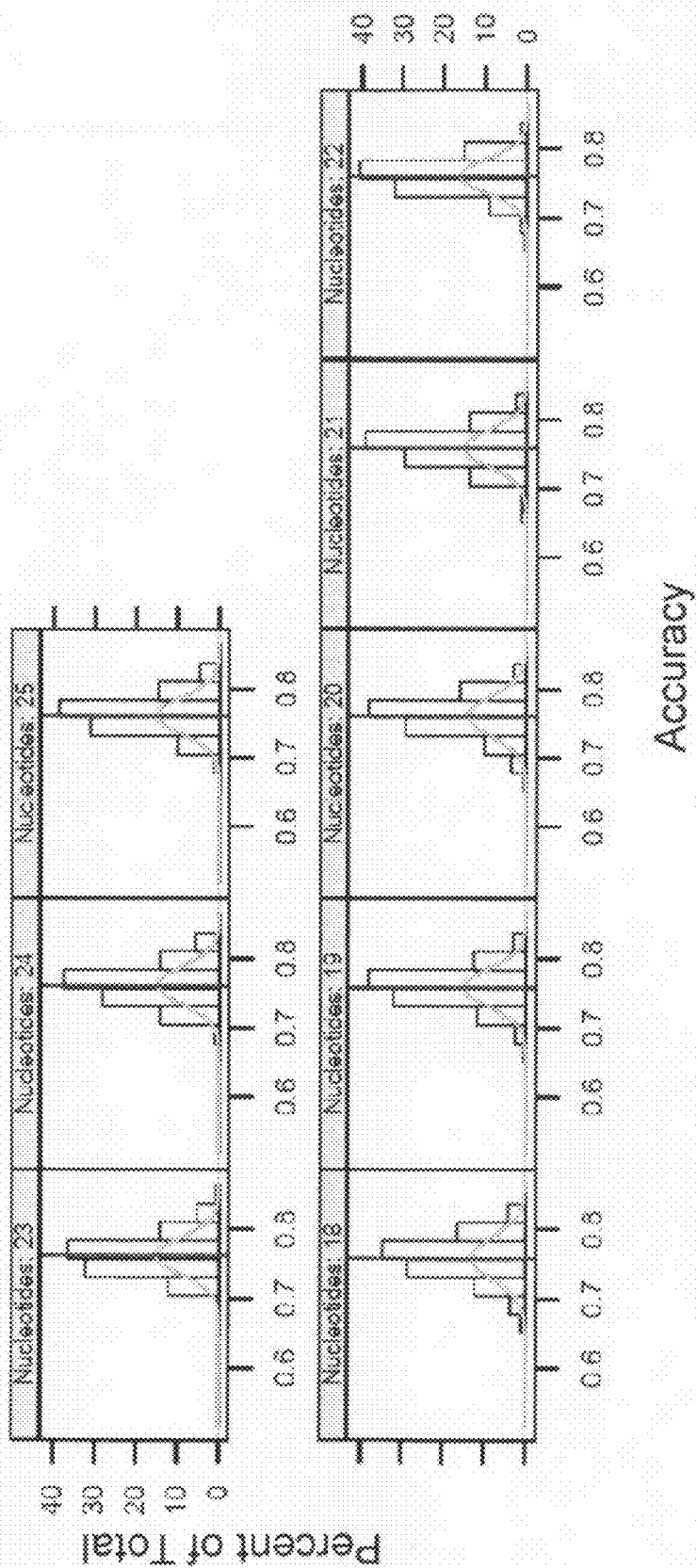

FIG. 66A

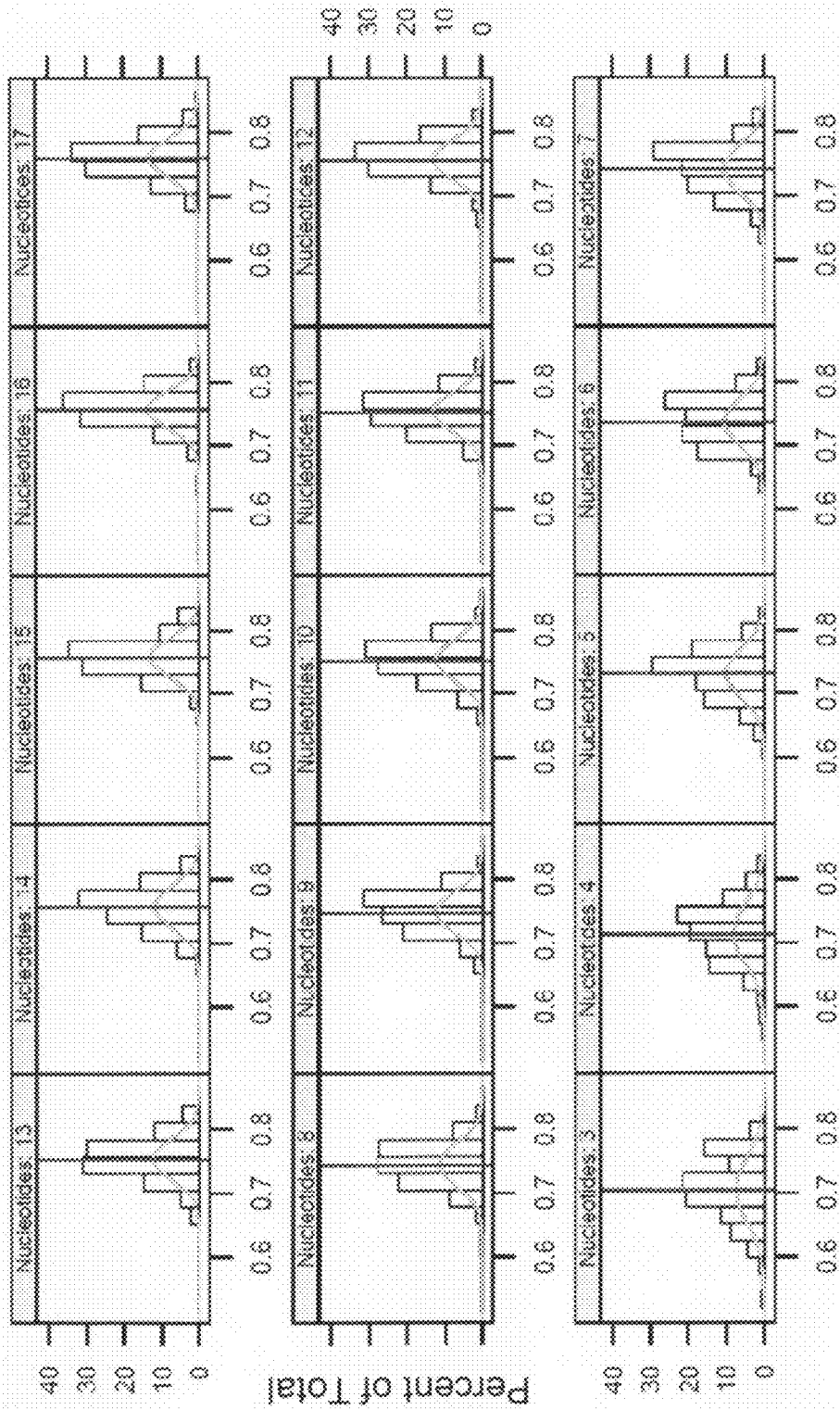

FIG. 66B Accuracy

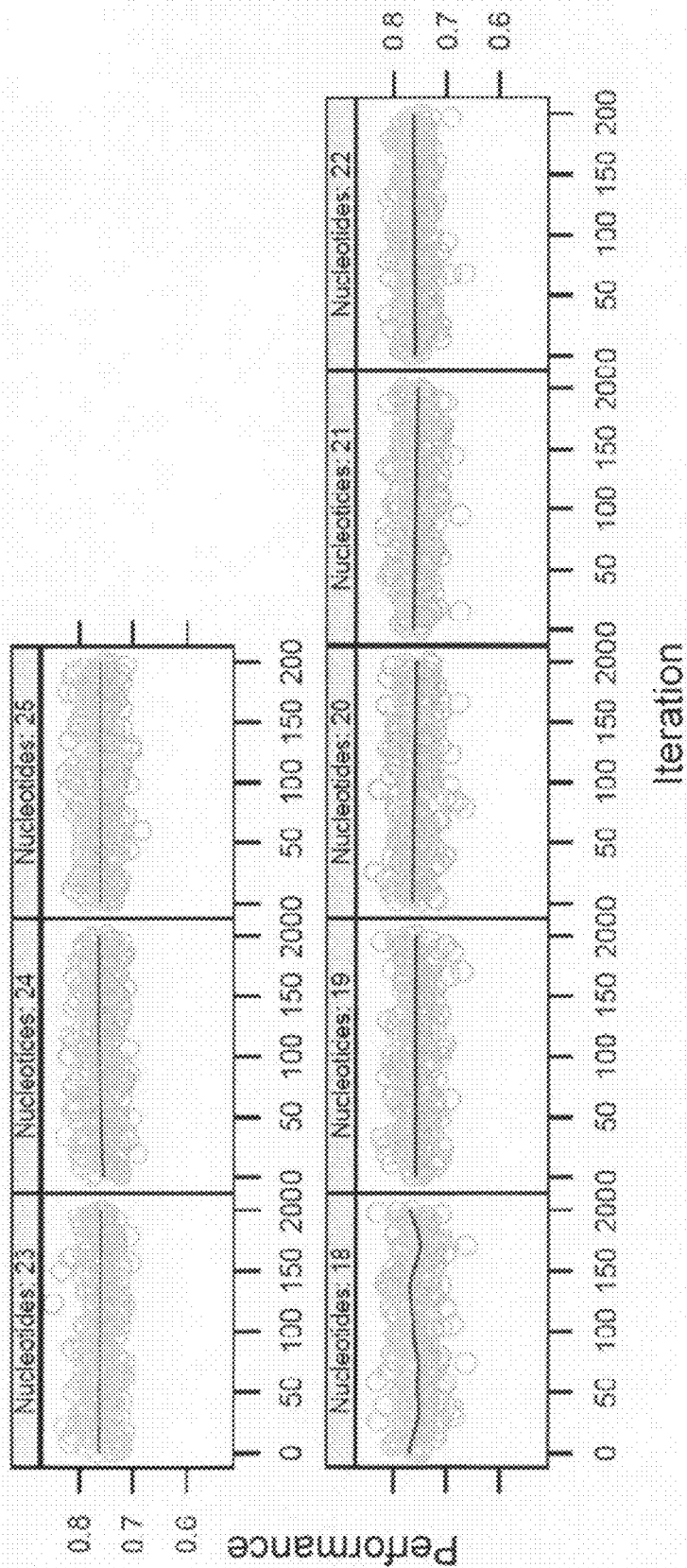

FIG. 67A

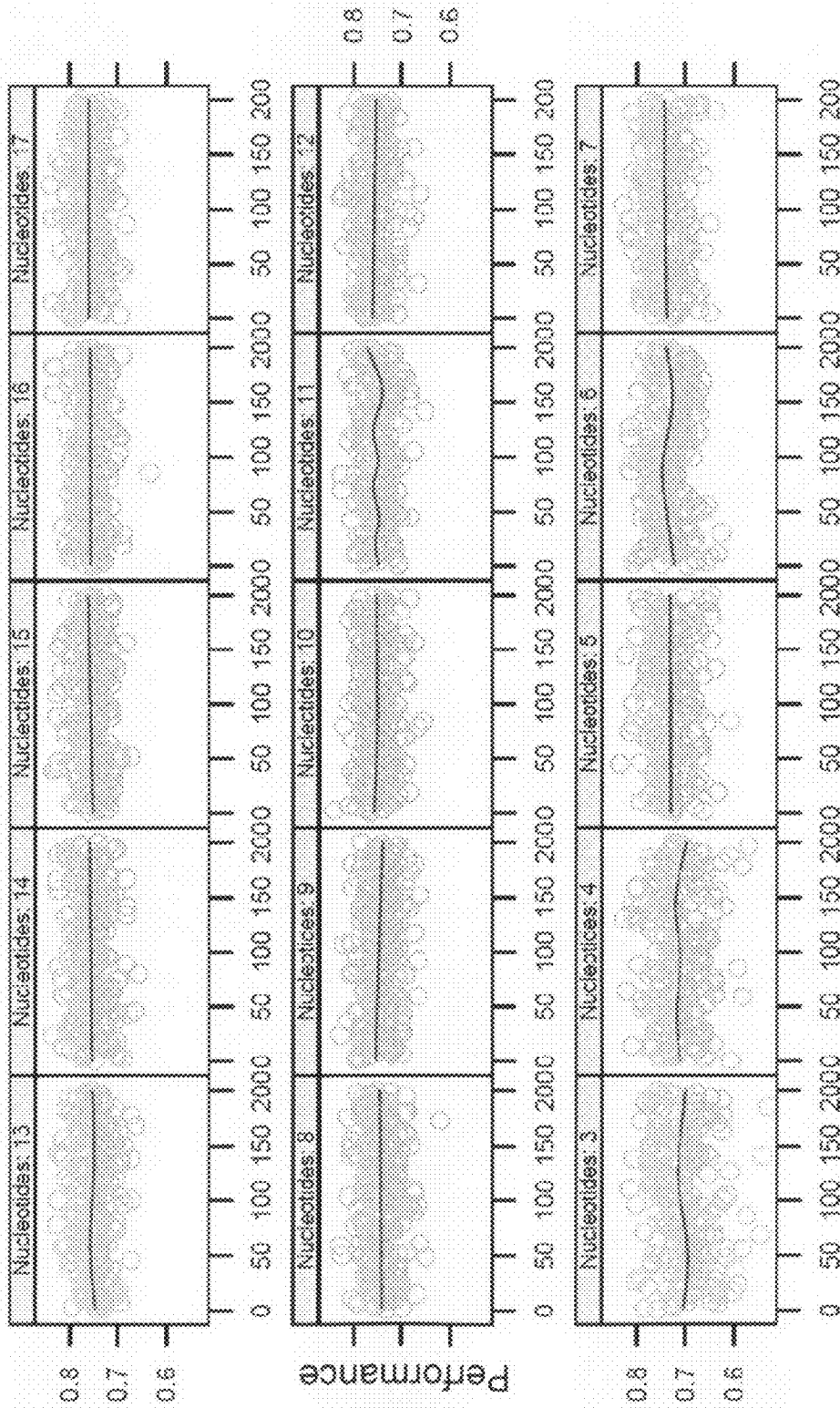

FIG. 67B Iteration

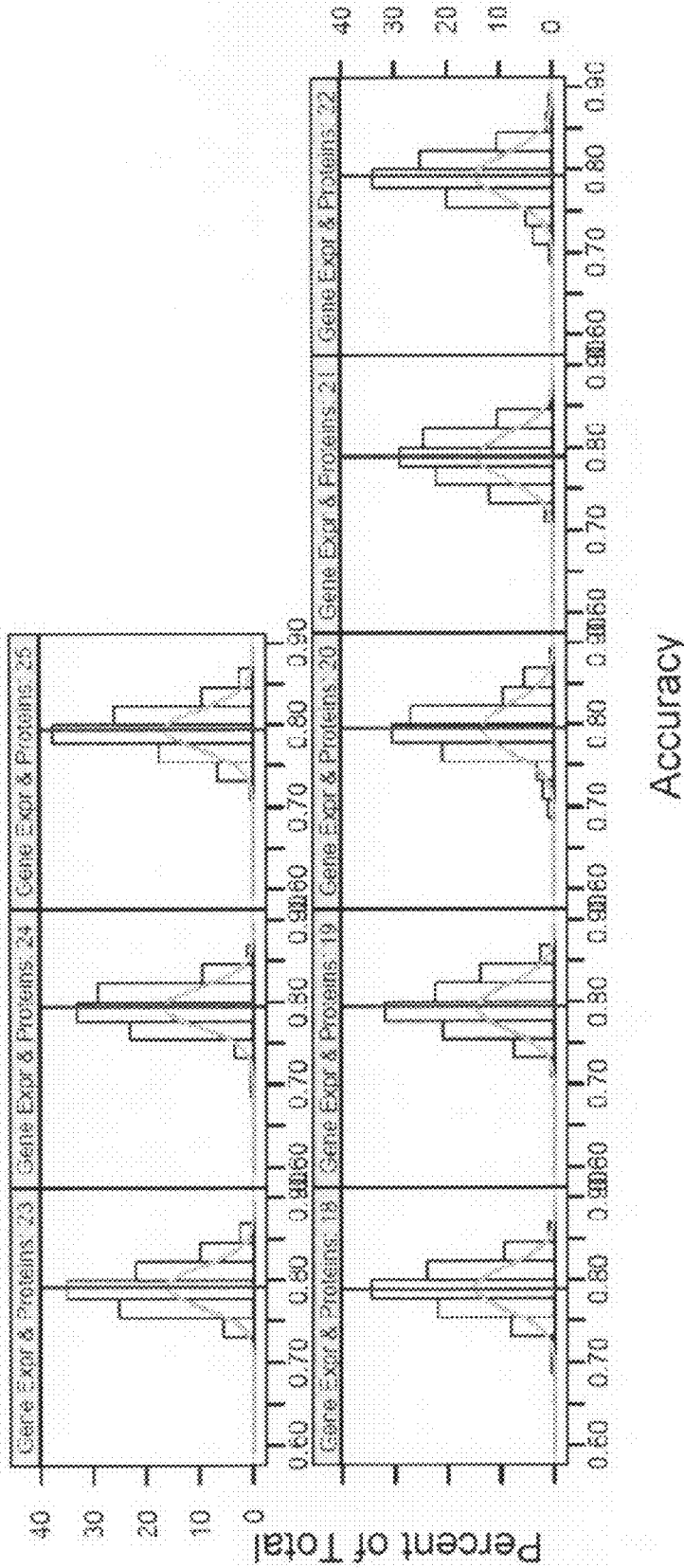

FIG. 68A

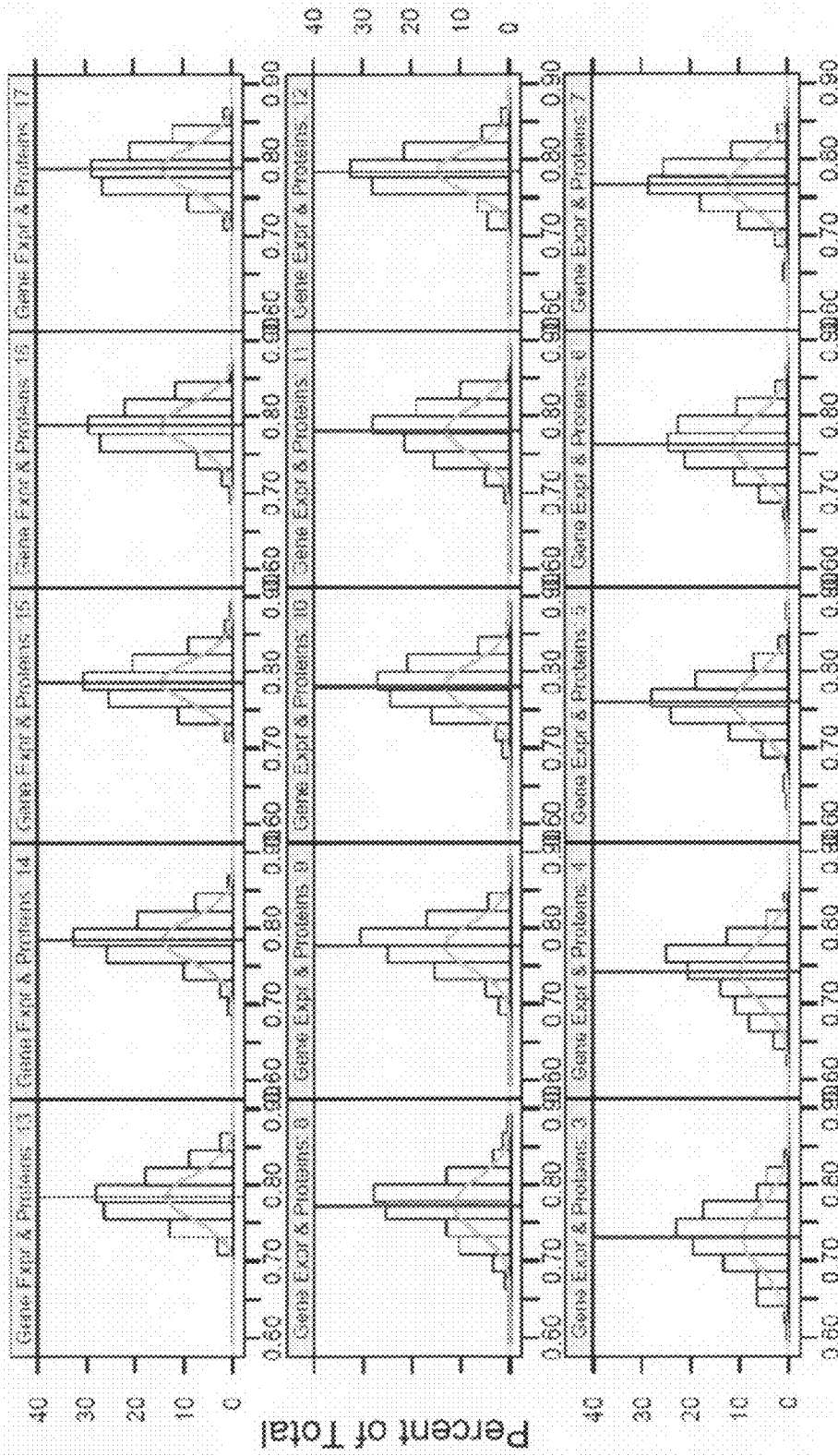

FIG. 68B Accuracy

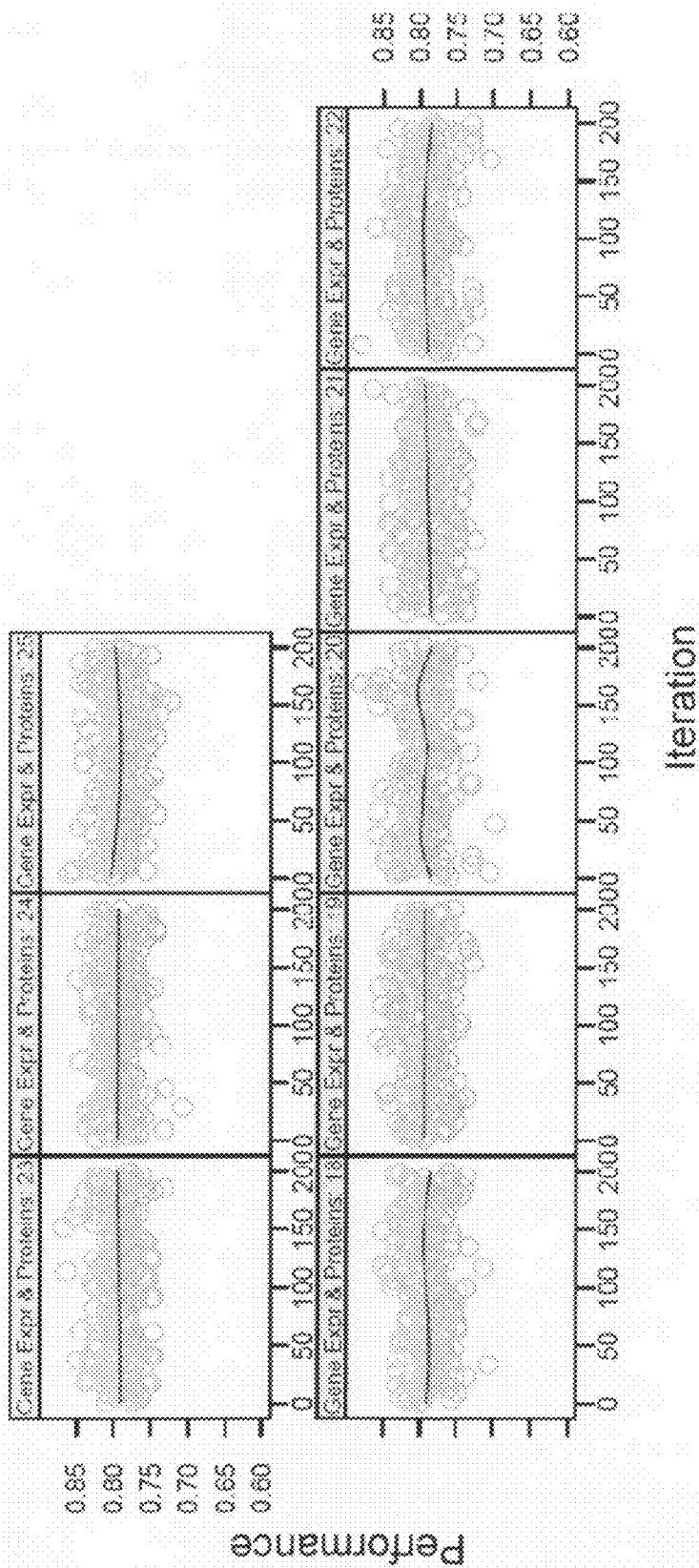

FIG. 69A

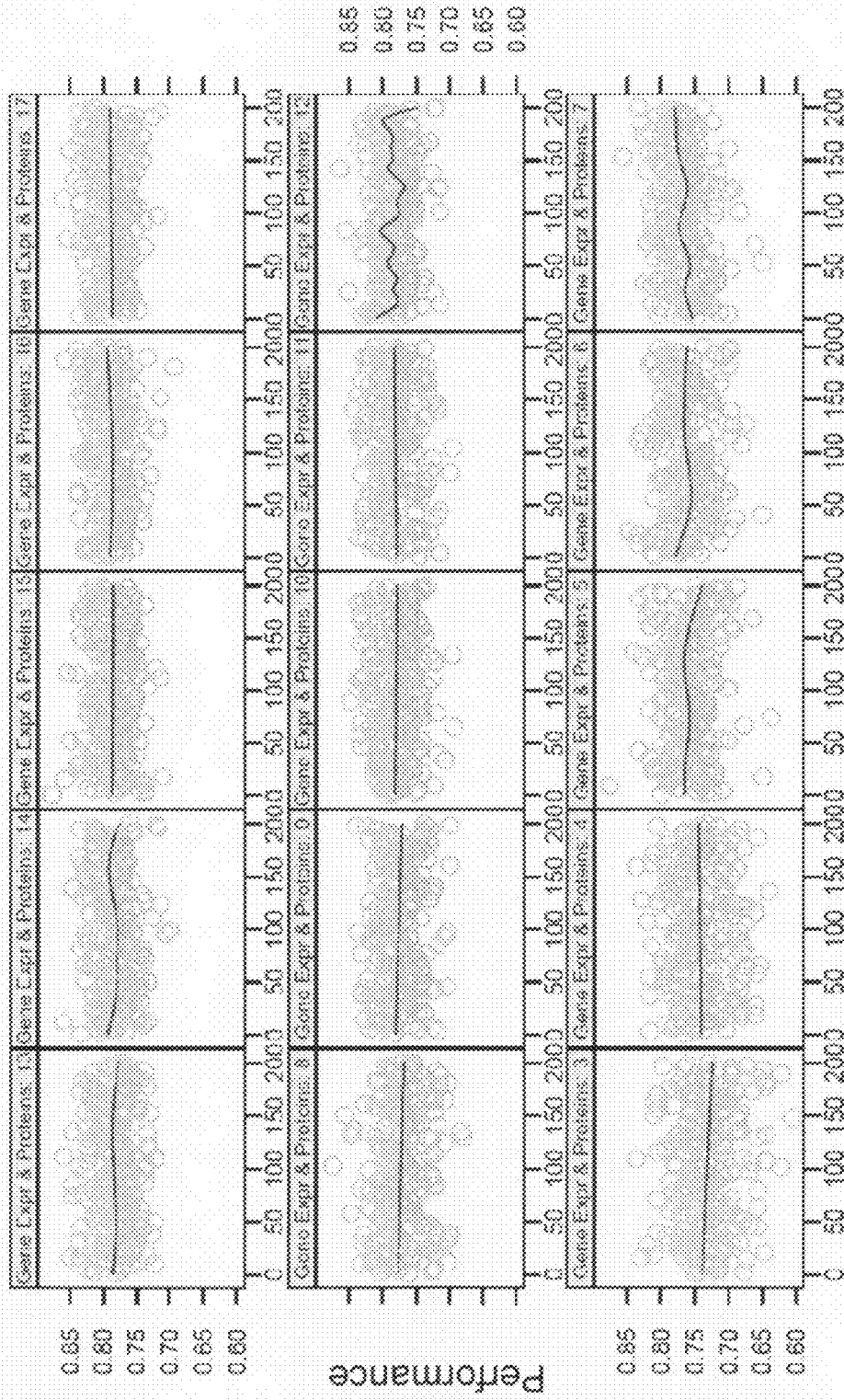

FIG. 69B Iteration

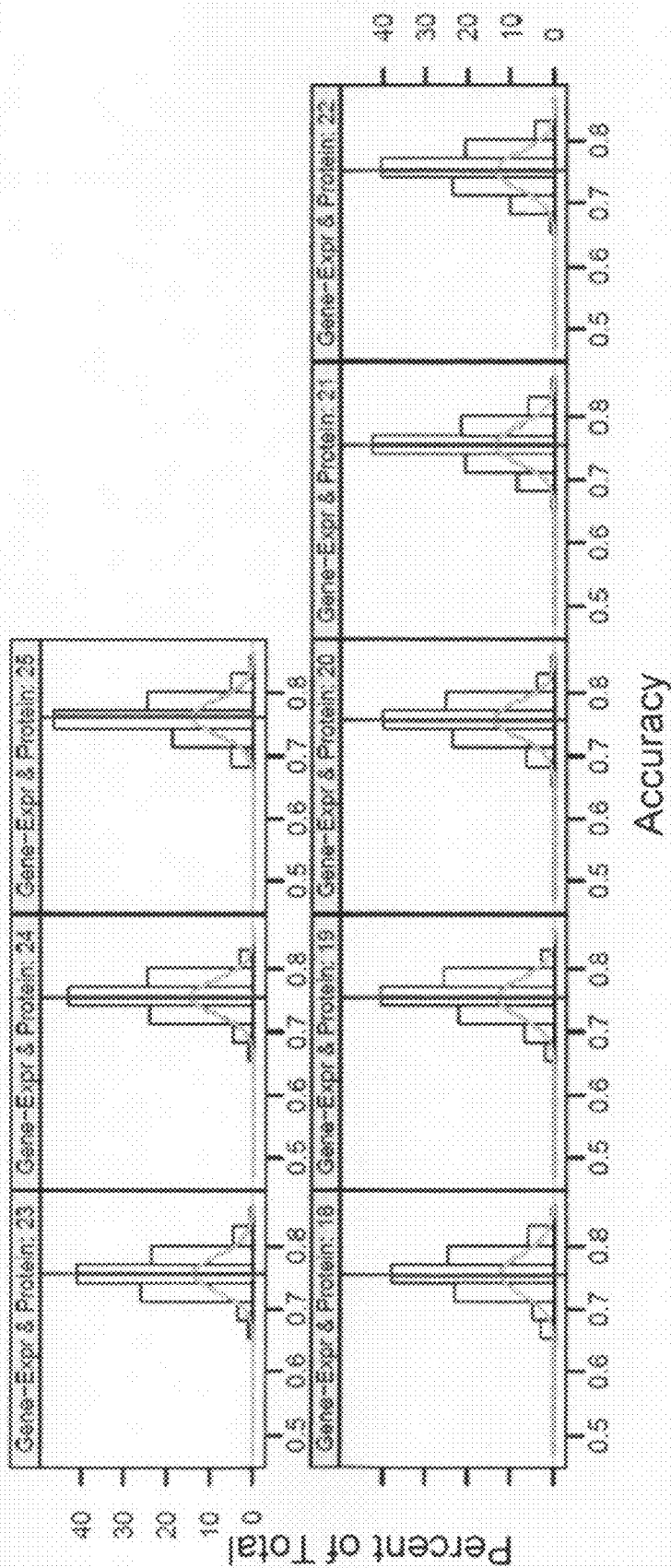

FIG. 70A

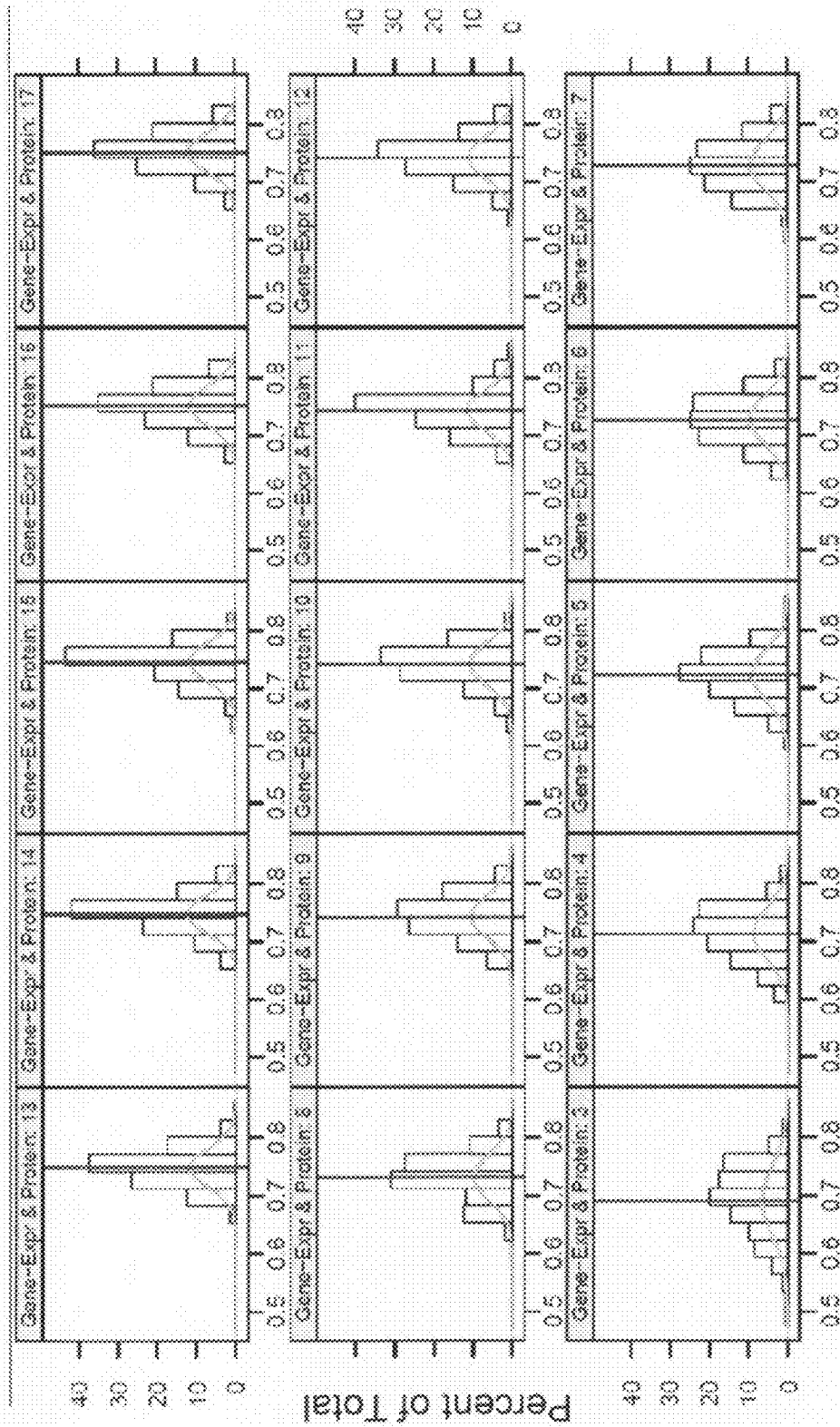

FIG. 70B Accuracy

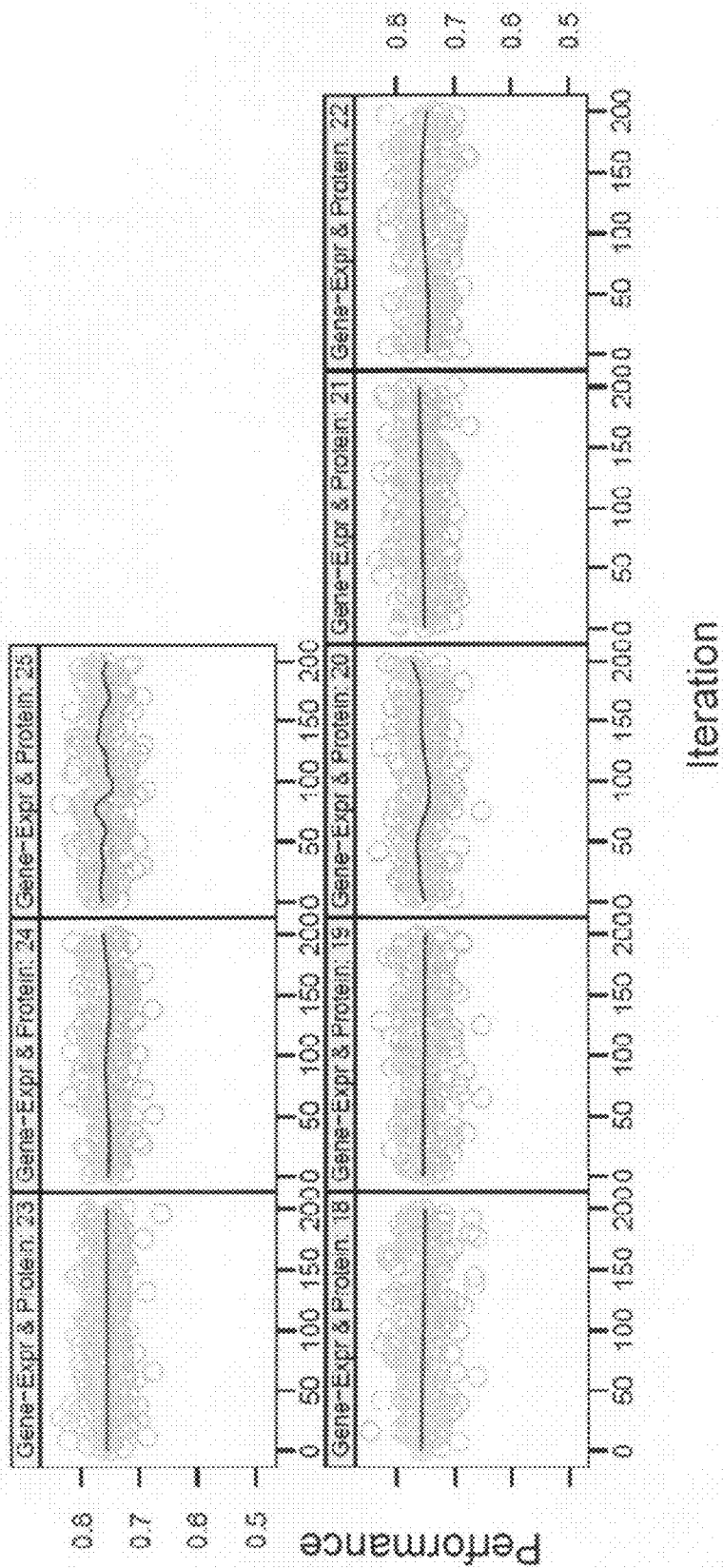

FIG.71A

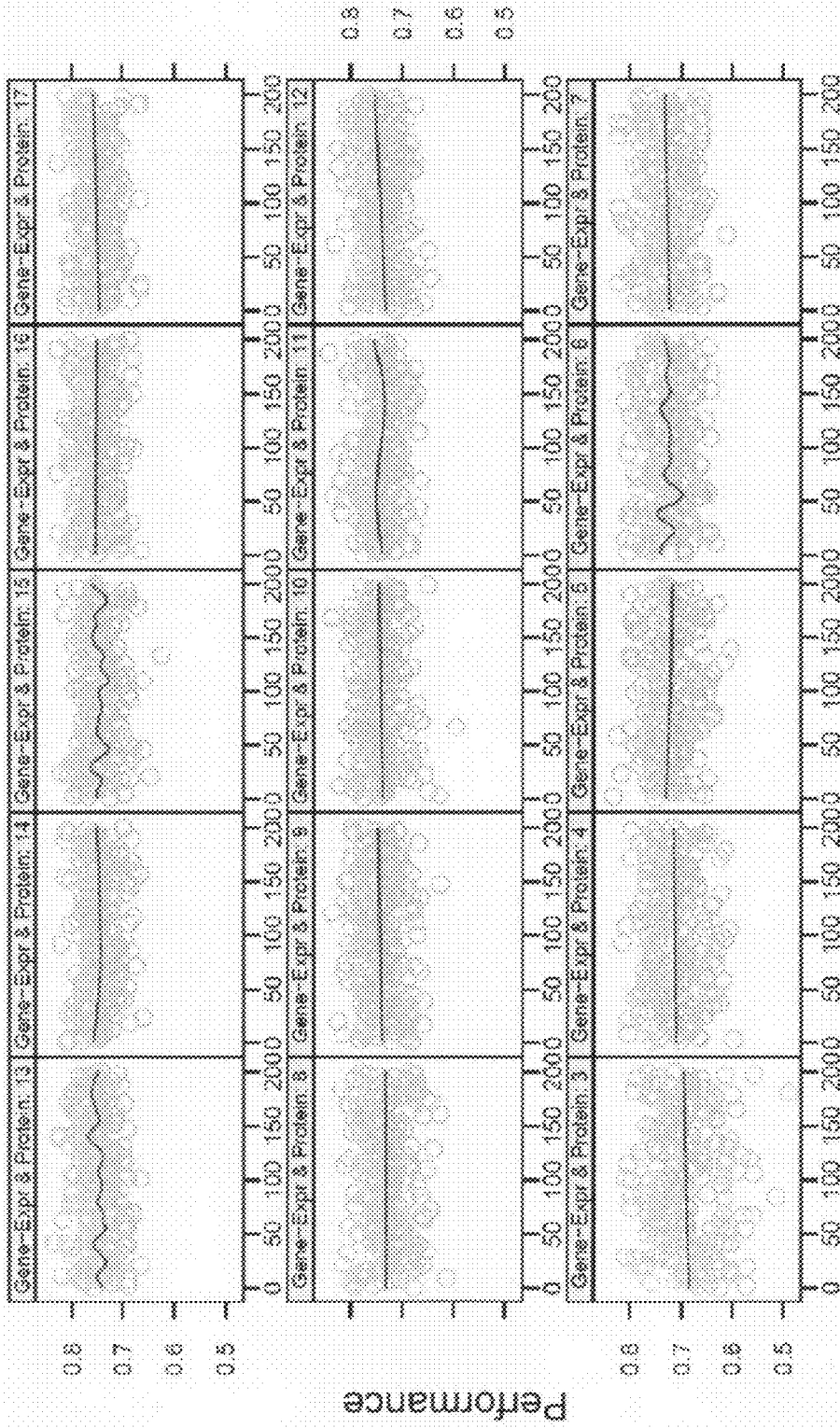

FIG.71B

DIAGNOSIS OF SEPSIS

CROSS-REFERENCE TO RELATED APPLICATIONS

[0001] This application claims benefit, under 35 U.S.C. §119(e), of U.S. Provisional Patent Application No. 60/671,620, filed on Apr. 15, 2005, which hereby is incorporated herein, by reference, in its entirety. This application also claims benefit, under 35 U.S.C. §119(e), of U.S. Provisional Patent Application No. 60/674,046, filed on Apr. 22, 2005, which is hereby incorporated herein, by reference, in its entirety.

1. FIELD OF THE INVENTION

[0002] The present invention relates to methods and compositions for diagnosing or predicting sepsis and/or its stages of progression in a subject. The present invention also relates to methods and compositions for diagnosing systemic inflammatory response syndrome in a subject.

2. BACKGROUND OF THE INVENTION

[0003] Early detection of a disease condition typically allows for a more effective therapeutic treatment with a correspondingly more favorable clinical outcome. In many cases, however, early detection of disease symptoms is problematic due to the complexity of the disease; hence, a disease may become relatively advanced before diagnosis is possible. Systemic inflammatory conditions represent one such class of diseases. These conditions, particularly sepsis, typically, but not always, result from an interaction between a pathogenic microorganism and the host's defense system that triggers an excessive and dysregulated inflammatory response in the host. The complexity of the host's response during the systemic inflammatory response has complicated efforts towards understanding disease pathogenesis (reviewed in Healy, 2002, *Annul. Pharmacother.* 36:648-54). An incomplete understanding of the disease pathogenesis, in turn, contributes to the difficulty in finding useful diagnostic biomarkers. Early and reliable diagnosis is imperative, however, because of the remarkably rapid progression of sepsis into a life-threatening condition.

[0004] The development of sepsis in a subject follows a well-described course, progressing from systemic inflammatory response syndrome ("SIRS")-negative, to SIRS-positive, and then to sepsis, which may then progress to severe sepsis, septic shock, multiple organ dysfunction ("MOD"), and ultimately death. Sepsis may also arise in an infected subject when the subject subsequently develops SIRS. "Sepsis" is commonly defined as the systemic host response to infection with SIRS plus a documented infection. "Severe sepsis" is associated with MOD, hypotension, disseminated intravascular coagulation ("DIC") or hypoperfusion abnormalities, including lactic acidosis, oliguria, and changes in mental status. "Septic shock" is commonly defined as sepsis-induced hypotension that is resistant to fluid resuscitation with the additional presence of hypoperfusion abnormalities.

[0005] Documenting the presence of the pathogenic microorganisms that are clinically significant to sepsis has proven difficult. Causative microorganisms typically are detected by culturing a subject's blood, sputum, urine, wound secretion, in-dwelling line catheter surfaces, etc. Causative microorganisms, however, may reside only in certain body microenvironments such that the particular material that is cultured may

not contain the contaminating microorganisms. Detection may be complicated further by low numbers of microorganisms at the site of infection. Low numbers of pathogens in blood present a particular problem for diagnosing sepsis by culturing blood. In one study, for example, positive culture results were obtained in only 17% of subjects presenting clinical manifestations of sepsis (Rangel-Frausto et al., 1995, *JAMA* 273:117-123). Diagnosis can be further complicated by contamination of samples by non-pathogenic microorganisms. For example, only 12.4% of detected microorganisms were clinically significant in a study of 707 subjects with septicemia (Weinstein et al., 1997, *Clinical Infectious Diseases* 24:584-602).

[0006] The difficulty in early diagnosis of sepsis is reflected by the high morbidity and mortality associated with the disease. Sepsis currently is the tenth leading cause of death in the United States and is especially prevalent among hospitalized patients in non-coronary intensive care units (ICUs), where it is the most common cause of death. The overall rate of mortality is as high as 35%, with an estimated 750,000 cases per year occurring in the United States alone. The annual cost to treat sepsis in the United States alone is on the order of billions of dollars.

[0007] A need, therefore, exists for a method of diagnosing sepsis, using techniques that have satisfactory specificity and sensitivity performance, sufficiently early to allow effective intervention and prevention.

3. SUMMARY OF THE INVENTION

[0008] The present invention relates to methods and compositions for diagnosing sepsis, including the onset of sepsis, in a test subject. The present invention also relates to methods and compositions for predicting sepsis in a test subject.

[0009] The present invention further relates to methods and compositions for diagnosing or predicting stages of sepsis progression in a test subject. The present invention still further relates to methods and compositions for diagnosing systemic inflammatory response syndrome (SIRS) in a test subject.

[0010] In one aspect, the present invention provides a method of predicting the development of sepsis in a test subject at risk for developing sepsis. This method comprises evaluating whether a plurality of features in a biomarker profile of the test subject satisfies a value set, wherein satisfying the value set means that the test subject will develop sepsis with a likelihood that is determined by the accuracy of the decision rule to which the plurality of features are applied in order to determine whether they satisfy the value set. In some embodiments, the accuracy of the decision rule is at least 60%. Therefore, correspondingly, the likelihood that the test subject will develop sepsis when the plurality of features satisfies the value set is at least 60%.

[0011] Yet another aspect of the invention comprises a method of diagnosing sepsis in a test subject. These methods comprise evaluating whether a plurality of features in a biomarker profile of the test subject satisfies a value set, wherein satisfying the value set predicts that the test subject has sepsis with a likelihood that is determined by the accuracy of the decision rule to which the plurality of features are applied in order to determine whether they satisfy the value set. In some embodiments, the accuracy of the decision rule is at least 60%. Therefore, correspondingly, the likelihood that the test subject has sepsis when the plurality of features satisfies the value set is at least 60%.

[0012] In a particular embodiment, the biomarker profile comprises at least two features, each feature representing a feature of a corresponding biomarker listed in column four or five of Table 30. In one embodiment, the biomarker profile comprises at least two different biomarkers listed in column four or five of Table 30. In such an embodiment, the biomarker profile can comprise a respective corresponding feature for the at least two biomarkers. Generally, the at least two biomarkers are derived from at least two different genes. In the case where a biomarker in the at least two different biomarkers is listed in column four of Table 30, the biomarker can be, for example, a transcript made by the listed gene, a complement thereof, or a discriminating fragment or complement thereof, or a cDNA thereof, or a discriminating fragment of the cDNA, or a discriminating amplified nucleic acid molecule corresponding to all or a portion of the transcript or its complement, or a protein encoded by the gene, or a discriminating fragment of the protein, or an indication of any of the above. Further still, the biomarker can be, for example, a protein listed in column five of Table 30, or a discriminating fragment of the protein, or an indication of any of the above. Here, a discriminating molecule or fragment is a molecule or fragment that, when detected, indicates presence or abundance of the above-identified transcript, cDNA, amplified nucleic acid, or protein. In accordance with this embodiment, the biomarker profiles of the present invention can be obtained using any standard assay known to those skilled in the art, or in an assay described herein, to detect a biomarker. Such assays are capable, for example, of detecting the products of expression (e.g., nucleic acids and/or proteins) of a particular gene or allele of a gene of interest (e.g., a gene disclosed in Table 30). In one embodiment, such an assay utilizes a nucleic acid microarray. In some embodiments, the biomarker profile comprises at least two different biomarkers from column four or five of Table 32. In some embodiments, the biomarker profile comprises at least 2, 3, 4, 5, 6, 7, 8, 9, 10, 11, 12, 13, 14, 15, 16, 17, 18, 19, 20, 21, 22, 23, 24, 25, 30, 35, 40, 45, or 50 different biomarkers from Table 30.

[0013] In a particular embodiment, the biomarker profile comprises at least two different biomarkers that each contain one of the probesets listed in column 2 of Table 30, biomarkers that contain the complement of one of the probesets of Table 30, or biomarkers that contain an amino acid sequence encoded by a gene that either contains one of the probesets of Table 30 or the complement of one of the probesets of Table 30. Such biomarkers can be, for example, mRNA transcripts, cDNA or some other nucleic acid, for example amplified nucleic acid, or proteins. The biomarker profile further comprises a respective corresponding feature for the at least two biomarkers. Generally, the at least two biomarkers are derived from at least two different genes. In the case where a biomarker is based upon a gene that includes the sequence of a probeset listed in Table 30, the biomarker can be, for example, a transcript made by the gene, a complement thereof, or a discriminating fragment or complement thereof, or a cDNA thereof, or a discriminating fragment of the cDNA, or a discriminating amplified nucleic acid molecule corresponding to all or a portion of the transcript or its complement, or a protein encoded by the gene, or a discriminating fragment of the protein, or an indication of any of the above. Further still, the biomarker can be, for example, a protein encoded by a gene that includes a probeset sequence described in Table 30, or a discriminating fragment of the protein, or an indication of any of the above. Here, a discriminating molecule or fragment

is a molecule or fragment that, when detected, indicates presence or abundance of the above-identified transcript, cDNA, amplified nucleic acid, or protein. In some embodiments, the biomarker profile comprises at least 2, 3, 4, 5, 6, 7, 8, 9, or 10 different biomarkers from any one of Table 31, 32, 33, 34, or 36.

[0014] In a particular embodiment, the biomarker profile comprises at least two different biomarkers listed in column three of Table 31. The biomarker profile further comprises a respective corresponding feature for the at least two biomarkers. Generally, the at least two biomarkers are derived from at least two different genes. The biomarker can be, for example, a transcript made by gene listed in Table 31, a complement thereof, or a discriminating fragment or complement thereof, or a cDNA thereof, or a discriminating fragment of the cDNA, or a discriminating amplified nucleic acid molecule corresponding to all or a portion of the transcript or its complement, or a protein encoded by the gene, or a discriminating fragment of the protein, or an indication of any of the above. Further still, the biomarker can be, for example, a protein encoded by a gene listed in column three of Table 31, or a discriminating fragment of the protein, or an indication of any of the above. Here, a discriminating molecule or fragment is a molecule or fragment that, when detected, indicates presence or abundance of the above-identified transcript, cDNA, amplified nucleic acid, or protein. In accordance with this embodiment, the biomarker profiles of the present invention can be obtained using any standard assay known to those skilled in the art, or in an assay described herein, to detect a biomarker. Such assays are capable, for example, of detecting the products of expression (e.g., nucleic acids and/or proteins) of a particular gene or allele of a gene of interest (e.g., a gene disclosed in Table 31). In one embodiment, such an assay utilizes a nucleic acid microarray.

[0015] In a particular embodiment, the biomarker profile comprises at least two different biomarkers that each contain one of the probesets listed in column 2 of Table 31, biomarkers that contain the complement of one of the probesets of Table 31, or biomarkers that contain an amino acid sequence encoded by a gene that either contains one of the probesets of Table 31 or the complement of one of the probesets of Table 31. Such biomarkers can be, for example, mRNA transcripts, cDNA or some other nucleic acid, for example amplified nucleic acid, or proteins. The biomarker profile further comprises a respective corresponding feature for the at least two biomarkers. Generally, the at least two biomarkers are derived from at least two different genes. In the case where a biomarker is based upon a gene that includes the sequence of a probeset listed in Table 31, the biomarker can be, for example, a transcript made by the gene, a complement thereof, or a discriminating fragment or complement thereof, or a cDNA thereof, or a discriminating fragment of the cDNA, or a discriminating amplified nucleic acid molecule corresponding to all or a portion of the transcript or its complement, or a protein encoded by the gene, or a discriminating fragment of the protein, or an indication of any of the above. Further still, the biomarker can be, for example, a protein encoded by a gene that includes a probeset sequence described in Table 31, or a discriminating fragment of the protein, or an indication of any of the above. Here, a discriminating molecule or fragment is a molecule or fragment that, when detected, indicates presence or abundance of the above-identified transcript, cDNA, amplified nucleic acid, or protein. In some embodiments, the biomarker profile comprises at least 2, 3, 4, 5, 6, 7, 8, 9, 10, 11,

12, 13, 14, 15, 16, 17, 18, 19, 20, 21, 22, 23, 24, 25, 30, 35, 40, 45, or 50 different biomarkers from Table 3 I.

[0016] In a particular embodiment, the biomarker profile comprises at least three features, each feature representing a feature of a corresponding biomarker listed in column 3 or four of Table I. In one embodiment, the biomarker profile comprises at least three different biomarkers listed in column three or four of Table I. In such an embodiment, the biomarker profile can comprise a respective corresponding feature for the at least three biomarkers. Generally, the at least three biomarkers are derived from at least three different genes listed in Table I. In the case where a biomarker in the at least three different biomarkers is listed in column three of Table I, the biomarker can be, for example, a transcript made by the listed gene, a complement thereof, a splice variant thereof, a complement of a splice variant thereof, or a discriminating fragment or complement of any of the foregoing, a cDNA of any of the foregoing, a discriminating fragment of the cDNA, or a discriminating amplified nucleic acid molecule corresponding to all or a portion of the transcript or its complement, or a protein encoded by the gene, or a discriminating fragment of the protein, or an indication of any of the above. Further still, the biomarker can be, for example, a protein listed in column four of Table I, or a discriminating fragment of the protein, or an indication of any of the above. Here, a discriminating molecule or fragment is a molecule or fragment that, when detected, indicates presence or abundance of the above-identified transcript, cDNA, amplified nucleic acid, splice-variant thereof or protein. In accordance with this embodiment, the biomarker profiles of the present invention can be obtained using any standard assay known to those skilled in the art, or in an assay described herein, to detect a biomarker. Such assays are capable, for example, of detecting the products of expression (e.g., nucleic acids and/or proteins) of a particular gene or allele of a gene of interest (e.g., a gene disclosed in Table I). In one embodiment, such an assay utilizes a nucleic acid microarray. In some embodiments, the biomarker profile comprises at least 2, 3, 4, 5, 6, 7, 8, 9, 10, 11, 12, 13, 14, 15, 16, 17, 18, 19, 20, 21, 22, 23, 24, 25, 30, 35, 40, 45, or 50 different biomarkers from Table I.

[0017] In a particular embodiment, the biomarker profile comprises at least three features, each feature representing a feature of a corresponding biomarker listed in column 3 or four of Table J. In one embodiment, the biomarker profile comprises at least three different biomarkers listed in column three or four of Table J. In such an embodiment, the biomarker profile can comprise a respective corresponding feature for the at least three biomarkers. Generally, the at least three biomarkers are derived from at least three different genes. In the case where a biomarker in the at least three different biomarkers is listed in column three of Table J, the biomarker can be, for example, a transcript made by the listed gene, a complement thereof, a splice variant thereof, a complement of a splice variant thereof, or a discriminating fragment or complement of any of the foregoing, a cDNA of any of the foregoing, a discriminating fragment of the cDNA, or a discriminating amplified nucleic acid molecule corresponding to all or a portion of the transcript or its complement, or a protein encoded by the gene, or a discriminating fragment of the protein, or an indication of any of the above. Further still, the biomarker can be, for example, a protein listed in column four of Table J, or a discriminating fragment of the protein, or an indication of any of the above. Here, a discriminating molecule or fragment is a molecule or fragment that, when

detected, indicates presence or abundance of the above-identified transcript, cDNA, amplified nucleic acid, splice-variant thereof or protein. In accordance with this embodiment, the biomarker profiles of the present invention can be obtained using any standard assay known to those skilled in the art, or in an assay described herein, to detect a biomarker. Such assays are capable, for example, of detecting the products of expression (e.g., nucleic acids and/or proteins) of a particular gene or allele of a gene of interest (e.g., a gene disclosed in Table J). In one embodiment, such an assay utilizes a nucleic acid microarray. In some embodiments, the biomarker profile comprises at least 2, 3, 4, 5, 6, 7, 8, 9, 10, 11, 12, 13, 14, 15, 16, 17, 18, 19, 20, 21, 22, 23, 24, 25, 30, 35, 40 different biomarkers from Table J.

[0018] In a particular embodiment, the biomarker profile comprises at least three features, each feature representing a feature of a corresponding biomarker listed in column 3 or four of Table K. In one embodiment, the biomarker profile comprises at least three different biomarkers listed in column three or four of Table K. In such an embodiment, the biomarker profile can comprise a respective corresponding feature for the at least three biomarkers. Generally, the at least two or three biomarkers are derived from at least two or three different genes, respectively. In the case where a biomarker in the at least two or three different biomarkers is listed in column three of Table K, the biomarker can be, for example, a transcript made by the listed gene, a complement thereof, a splice variant thereof, a complement of a splice variant thereof, or a discriminating fragment or complement of any of the foregoing, a cDNA of any of the foregoing, a discriminating fragment of the cDNA, or a discriminating amplified nucleic acid molecule corresponding to all or a portion of the transcript or its complement, or a protein encoded by the gene, or a discriminating fragment of the protein, or an indication of any of the above. Further still, the biomarker can be, for example, a protein listed in column four of Table K, or a discriminating fragment of the protein, or an indication of any of the above. Here, a discriminating molecule or fragment is a molecule or fragment that, when detected, indicates presence or abundance of the above-identified transcript, cDNA, amplified nucleic acid, splice-variant thereof or protein. In accordance with this embodiment, the biomarker profiles of the present invention can be obtained using any standard assay known to those skilled in the art, or in an assay described herein, to detect a biomarker. Such assays are capable, for example, of detecting the products of expression (e.g., nucleic acids and/or proteins) of a particular gene or allele of a gene of interest (e.g., a gene disclosed in Table K). In one embodiment, such an assay utilizes a nucleic acid microarray. In some embodiments, the biomarker profile comprises at least 2, 3, 4, 5, 6, 7, 8, 9, 10 different biomarkers from Table K.

[0019] Although the methods of the present invention are particularly useful for detecting or predicting the onset of sepsis in SIRS subjects, one of skill in the art will understand that the present methods may be used for any subject: including, but not limited to, subjects suspected of having SIRS or of being at any stage of sepsis. For example, a biological sample can be taken from a subject, and a profile of biomarkers in the sample can be evaluated in light of biomarker profiles obtained from several different types of training populations. Representative training populations variously include, for example, populations that include subjects who are SIRS-negative, populations that include subjects who are SIRS-positive, and/or populations that include subjects at a

particular stage of sepsis. Evaluation of the biomarker profile in light of each of these different training populations can be used to determine whether the test subject is SIRS-negative, SIRS-positive, is likely to become septic, or has a particular stage of sepsis. Based on the diagnosis resulting from the methods of the present invention, an appropriate treatment regimen can then be initiated.

[0020] In particular embodiments, the invention also provides kits that are useful in diagnosing or predicting the development of sepsis or SIRS in a subject (see Section 5.3, *infra*). The kits of the present invention comprise at least 2, 3, 4, 5, 6, 7, 8, 9, 10, 11, 12, 13, 14, 15, 16, 17, 18, 19, 20, 25, 30, 35, 40, 45, 50, 55, 60, 65, 70, 75, 80, 85, 90, 95, 96, 100, 105, 110, 115, 120, 125, 130, 135, 140, 145, 150, 155, 160, 165, 170, 175, 180, 185, 190, 195 or 200 or more biomarkers and/or reagents used to detect the presence or abundance of such biomarkers. In some embodiments, each of these biomarkers is from Table 30. In some embodiments, each of these biomarkers is from Table 31. In some embodiments, each of these biomarkers is from Table 32. In some embodiments, each of these biomarkers is from Table 33. In some embodiments, each of these biomarkers is from Table 36. In some embodiments, each of these biomarkers is from FIG. 39, FIG. 43, FIG. 52, FIG. 53, or FIG. 56. In another embodiment, the kits of the present invention comprise at least two, but as many as several hundred or more biomarkers and/or reagents used to detect the presence or abundance of such biomarkers.

[0021] In a specific embodiment, the kits of the present invention comprise at least 2, 3, 4, 5, 6, 7, 8, 9, 10, 11, 12, 13, 14, 15, 16, 17, 18, 19, 20, 25, 30, 35, 40, 45, 50, 55, 60, 65, 70, 75, 80, 85, 90, 95, 96, 100, 105, 110, 115, 120, 125, 130, 135, 140, 145, 150, 155, 160, 165, 170, 175, 180, 185, 190, 195 or 200 or more reagents that specifically bind the biomarkers of the present invention. For example, such kits can comprise nucleic acid molecules and/or antibody molecules that specifically bind to biomarkers of the present invention.

[0022] Specific exemplary biomarkers that are useful in the present invention are set forth in Section 5.6, Section 5.11, as well as Tables 30, 31, 32, 34 and 36 of Section 6. The biomarkers of the kit can be used to generate biomarker profiles according to the present invention. Examples of types of biomarkers and/or reagents within such kits include, but are not limited to, proteins and fragments thereof, peptides, polypeptides, antibodies, proteoglycans, glycoproteins, lipoproteins, carbohydrates, lipids, nucleic acids (mRNA, DNA, cDNA), organic and inorganic chemicals, and natural and synthetic polymers or a discriminating molecule or fragment thereof.

[0023] In particular embodiments, the invention also provides still other kits that are useful in diagnosing or predicting the development of sepsis or SIRS in a subject (see Section 5.3, *infra*). The kits of the present invention comprise at least 2, 3, 4, 5, 6, 7, 8, 9, 10, 11, 12, 13, 14, 15, 16, 17, 18, 19, 20, 25, 30, 35, 40, 45, 50 or more biomarkers. In some embodiments, each of these biomarkers is from Table I. In some embodiments, each of these biomarkers is from Table J. In some embodiments, each of these biomarkers is from Table K. In some embodiments, each of these biomarkers is found in Table I or Table 30. In some embodiments, each of these biomarkers is found in Table I or Table 31. In some embodiments, each of these biomarkers is from FIG. 39, FIG. 43, FIG. 52, FIG. 53, or FIG. 56. In another embodiment, the kits of the present invention comprise at least two, but as many as 50 or more biomarkers. In a specific embodiment, the kits of

the present invention comprise at least 2, 3, 4, 5, 6, 7, 8, 9, 10, 11, 12, 13, 14, 15, 16, 17, 18, 19, 20, 25, 30, 35, 40, 45, 50, 55, 60, 65, 70, 75, 80, 85, 90, 95, 96, 100, 105, 110, 115, 120, 125, 130, 135, 140, 145, 150, 155, 160, 165, 170, 175, 180, 185, 190, 195 or 200 or more reagents that specifically bind the biomarkers of the present invention. Specific biomarkers that are useful in the present invention are set forth in Section 5.6, Section 5.11, as well as Tables I, J, K, L, M, N, and O. The biomarkers of the kits can be used to generate biomarker profiles according to the present invention. Examples of classes of compounds of the kits include, but are not limited to, proteins and fragments thereof, peptides, polypeptides, proteoglycans, glycoproteins, lipoproteins, carbohydrates, lipids, nucleic acids (mRNA, DNA, cDNA), organic and inorganic chemicals, and natural and synthetic polymers or a discriminating molecule or fragment thereof.

[0024] Still another aspect of the present invention comprises computers and computer readable media for evaluating whether a test subject is likely to develop sepsis or SIRS. For instance, one embodiment of the present invention provides a computer program product for use in conjunction with a computer system. The computer program product comprises a computer readable storage medium and a computer program mechanism embedded therein. The computer program mechanism comprises instructions for evaluating whether a plurality of features in a biomarker profile of a test subject at risk for developing sepsis satisfies a first value set. Satisfaction of the first value set predicts that the test subject is likely to develop sepsis. The features are measurable aspects of a plurality of biomarkers comprising at least three biomarkers listed in Table I. In some embodiments, the computer program product further comprises instructions for evaluating whether the plurality of features in the biomarker profile of the test subject satisfies a second value set. Satisfaction of the second value set predicts that the test subject is not likely to develop sepsis. In some embodiments, the biomarker profile has between 3 and 50 biomarkers listed in Table I, between 3 and 40 biomarkers listed in Table I, at least four biomarkers listed in Table I, or at least six biomarkers listed in Table I.

[0025] Another computer embodiment of the present invention comprises a central processing unit and a memory coupled to the central processing unit. The memory stores instructions for evaluating whether a plurality of features in a biomarker profile of a test subject at risk for developing sepsis satisfies a first value set. Satisfaction of the first value set predicts that the test subject is likely to develop sepsis. The features are measurable aspects of a plurality of biomarkers. This plurality of biomarkers comprises at least three biomarkers from Table I. In some embodiments, the memory further stores instructions for evaluating whether the plurality of features in the biomarker profile of the test subject satisfies a second value set, wherein satisfying the second value set predicts that the test subject is not likely to develop sepsis. In some embodiments, the biomarker profile consists of between 3 and 50 biomarkers listed in Table I, between 3 and 40 biomarkers listed in Table I, at least four biomarkers listed in Table I, or at least eight biomarkers listed in Table I.

[0026] Another computer embodiment in accordance with the present invention comprises a computer system for determining whether a subject is likely to develop sepsis. The computer system comprises a central processing unit and a memory, coupled to the central processing unit. The memory stores instructions for obtaining a biomarker profile of a test subject. The biomarker profile comprises a plurality of fea-

tures. The plurality of biomarkers comprises at least three biomarkers listed in Table I. The memory further comprises instructions for transmitting the biomarker profile to a remote computer. The remote computer includes instructions for evaluating whether the plurality of features in the biomarker profile of the test subject satisfies a first value set. Satisfaction of the first value set predicts that the test subject is likely to develop sepsis. The memory further comprises instructions for receiving a determination, from the remote computer, as to whether the plurality of features in the biomarker profile of the test subject satisfies the first value set. The memory also comprises instructions for reporting whether the plurality of features in the biomarker profile of the test subject satisfies the first value set. In some embodiments, the remote computer further comprises instructions for evaluating whether the plurality of features in the biomarker profile of the test subject satisfies a second value set. Satisfaction of the second value set predicts that the test subject is not likely to develop sepsis. In such embodiments, the memory further comprises instructions for receiving a determination, from the remote computer, as to whether the plurality of features in the biomarker profile of the test subject satisfies the second set as well as instructions for reporting whether the plurality of features in the biomarker profile of the test subject satisfies the second value set. In some embodiments, the plurality of biomarkers comprises at least four biomarkers listed in Table I. In some embodiments, the plurality of biomarkers comprises at least six biomarkers listed in Table I.

[0027] Still another embodiment of the present invention comprises a digital signal embodied on a carrier wave comprising a respective value for each of a plurality of features in a biomarker profile. The features are measurable aspects of a plurality of biomarkers. The plurality of biomarkers comprises at least three biomarkers listed in Table I. In some embodiments, the plurality of biomarkers comprises at least four biomarkers listed in Table I. In some embodiments, the plurality of biomarkers comprises at least eight biomarkers listed in Table I.

[0028] Still another aspect of the present invention provides a digital signal embodied on a carrier wave comprising a determination as to whether a plurality of features in a biomarker profile of a test subject satisfies a value set. The features are measurable aspects of a plurality of biomarkers. This plurality of biomarkers comprises at least three biomarkers listed in Table I. Satisfying the value set predicts that the test subject is likely to develop sepsis. In some embodiments, the plurality of biomarkers comprises at least four biomarkers listed in Table I. In some embodiments, the plurality of biomarkers comprises at least eight biomarkers listed in Table I.

[0029] Still another embodiment provides a digital signal embodied on a carrier wave comprising a determination as to whether a plurality of features in a biomarker profile of a test subject satisfies a value set. The features are measurable aspects of a plurality of biomarkers. The plurality of biomarkers comprises at least three biomarkers listed in Table I. Satisfaction of the value set predicts that the test subject is not likely to develop sepsis. In some embodiments, the plurality of biomarkers comprises at least four biomarkers listed in Table I. In some embodiments, the plurality of biomarkers comprises at least eight biomarkers listed in Table I.

[0030] Still another embodiment of the present invention provides a graphical user interface for determining whether a subject is likely to develop sepsis. The graphical user interface comprises a display field for a displaying a result

encoded in a digital signal embodied on a carrier wave received from a remote computer. The features are measurable aspects of a plurality of biomarkers. The plurality of biomarkers comprises at least three biomarkers listed in Table I. The result has a first value when a plurality of features in a biomarker profile of a test subject satisfies a first value set. The result has a second value when a plurality of features in a biomarker profile of a test subject satisfies a second value set. In some embodiments, the plurality of biomarkers comprises at least four biomarkers listed in Table I. In some embodiments, the plurality of biomarkers comprises at least eight biomarkers listed in Table I.

[0031] Yet another aspect of the present invention provides a computer system for determining whether a subject is likely to develop sepsis. The computer system comprises a central processing unit and a memory, coupled to the central processing unit. The memory stores instructions for obtaining a biomarker profile of a test subject. The biomarker profile comprises a plurality of features. The features are measurable aspects of a plurality of biomarkers. The plurality of biomarkers comprise at least three biomarkers listed in Table I. The memory further stores instructions for evaluating whether the plurality of features in the biomarker profile of the test subject satisfies a first value set. Satisfying the first value set predicts that the test subject is likely to develop sepsis. The memory also stores instructions for reporting whether the plurality of features in the biomarker profile of the test subject satisfies the first value set. In some embodiments, the plurality of biomarkers comprises at least four biomarkers listed in Table I. In some embodiments, the plurality of biomarkers comprises at least eight biomarkers listed in Table I.

4. BRIEF DESCRIPTION OF THE FIGURES

[0032] FIG. 1 illustrates a classification and regression tree for discriminating between a SIRS phenotypic state characterized by the onset of sepsis and a SIRS phenotypic state characterized by the absence of sepsis using $T_{-3,6}$ static data obtained from a training population in accordance with an embodiment of the present invention.

[0033] FIG. 2 shows the distribution of feature values for five biomarkers used in the decision tree of FIG. 1 across $T_{-3,6}$ static data obtained from a training population in accordance with an embodiment of the present invention. The biomarkers are referenced by their corresponding Affymetrix U133 plus 2.0 probeset names given in Table 30.

[0034] FIG. 3 illustrates the overall accuracy, sensitivity, and specificity of 500 trees used to train a decision tree using the Random Forests method based upon $T_{-3,6}$ static data obtained from a training population in accordance with an embodiment of the present invention.

[0035] FIG. 4 illustrates the biomarker importance in the decision rule trained using the trees of FIG. 3.

[0036] FIG. 5 illustrates the overall accuracy, with 95% confidence interval bars, specificity, and sensitivity of a decision rule developed with predictive analysis of microarrays (PAM) using the biomarkers of the present invention across $T_{-3,6}$ static data obtained from a training population.

[0037] FIG. 6 is a list of biomarkers, rank-ordered by their respective degrees of discriminatory power, identified by PAM using $T_{-3,6}$ static data obtained from a training population. The biomarkers are referenced by their corresponding Affymetrix U133 plus 2.0 probeset names given in Table 30.

[0038] FIG. 7 illustrates CART, PAM, and random forests classification algorithm performance data, and associated 95% confidence intervals, for T_{-36} static data obtained from a training population.

[0039] FIG. 8 illustrates the number of times that common biomarkers were found to be important across the decision rules developed using (i) CART, (ii) PAM, (iii) random forests, and (iv) the Wilcoxon (adjusted) test, for T_{-36} static data obtained from a training population.

[0040] FIG. 9 illustrates an overall ranking of biomarkers for T_{-36} static data obtained from a training population. The biomarkers are referenced by their corresponding Affymetrix U133 plus 2.0 probeset names given in Table 30.

[0041] FIG. 10 illustrates a classification and regression tree for discriminating between a SIRS phenotypic state characterized by the onset of sepsis and a SIRS phenotypic state characterized by the absence of sepsis using data using T_{-12} static data obtained from a training population in accordance with an embodiment of the present invention.

[0042] FIG. 11 shows the distribution of feature values for four biomarkers used in the decision tree of FIG. 10 using T_{-12} static data obtained from a training population in accordance with an embodiment of the present invention. The biomarkers are referenced by their corresponding Affymetrix U133 plus 2.0 probeset names given in Table 30.

[0043] FIG. 12 illustrates the overall accuracy, sensitivity, and specificity of 500 trees used to train a decision tree using the Random Forests method based upon T_{-12} static data obtained from a training population in accordance with an embodiment of the present invention.

[0044] FIG. 13 illustrates the biomarker importance in the decision rule trained using the trees of FIG. 12. The biomarkers are referenced by their corresponding Affymetrix U133 plus 2.0 probeset names given in Table 30.

[0045] FIG. 14 illustrates a calculation of biomarker importance, summing to 100%, determined by a multiple additive regression tree (MART) approach using T_{-12} static data obtained from a training population. The biomarkers are referenced by their corresponding Affymetrix U133 plus 2.0 probeset names given in Table 30.

[0046] FIG. 15 illustrates the distribution of feature values of the biomarkers selected by the MART approach illustrated in FIG. 14 between the Sepsis and SIRS groups using T_{-12} static data obtained from a training population. The biomarkers are referenced by their corresponding Affymetrix U133 plus 2.0 probeset names given in Table 30.

[0047] FIG. 16 illustrates the overall accuracy, with 95% confidence interval bars, specificity, and sensitivity of a decision rule developed with predictive analysis of microarrays (PAM) using the biomarkers of the present invention using T_{-12} static data obtained from a training population.

[0048] FIG. 17 is a list of biomarkers, rank-ordered by their respective degrees of discriminatory power, identified by PAM using T_{-12} static data obtained from a training population. The biomarkers are referenced by their corresponding Affymetrix U133 plus 2.0 probeset names given in Table 30.

[0049] FIG. 18 provides a summary of the CART, MART, PAM, and random forests (RF) classification algorithm (decision rule) performance and associated 95% confidence intervals using T_{-12} static data obtained from a training population.

[0050] FIG. 19 illustrates the number of times that common biomarkers were found to be important across the decision rules developed using (i) CART, (ii) MART, (iii) PAM, (iv)

random forests, and (v) the Wilcoxon (adjusted) test using T_{-12} static data obtained from a training population. The biomarkers are referenced by their corresponding Affymetrix U133 plus 2.0 probeset names given in Table 30.

[0051] FIG. 20 illustrates an overall ranking of biomarkers using T_{-12} static data obtained from a training population.

[0052] FIG. 21 illustrates a classification and regression tree for discriminating between a SIRS phenotypic state characterized by the onset of sepsis and a SIRS phenotypic state characterized by the absence of sepsis using T_{-12} baseline data obtained from a training population in accordance with an embodiment of the present invention.

[0053] FIG. 22 shows the distribution of the feature values of five biomarkers used in the decision tree of FIG. 21 using T_{-12} baseline data obtained from a training population in accordance with an embodiment of the present invention. The biomarkers are referenced by their corresponding Affymetrix U133 plus 2.0 probeset names given in Table 30.

[0054] FIG. 23 illustrates the overall accuracy, sensitivity, and specificity of 500 trees used to train a decision tree using the Random Forests method using T_{-12} baseline data obtained from a training population in accordance with an embodiment of the present invention.

[0055] FIG. 24 illustrates the biomarker importance in the decision rule trained using the trees of FIG. 23. The biomarkers are referenced by their corresponding Affymetrix U133 plus 2.0 probeset names given in Table 30.

[0056] FIG. 25 illustrates the overall accuracy, with 95% confidence interval bars, specificity, and sensitivity of a decision rule developed with predictive analysis of microarrays (PAM) using select biomarkers of the present invention and T_{-12} baseline data obtained from a training population.

[0057] FIG. 26 is a list of biomarkers, rank-ordered by their respective degrees of discriminatory power, identified by PAM using T_{-12} baseline data obtained from a training population. The biomarkers are referenced by their corresponding Affymetrix U133 plus 2.0 probeset names given in Table 30.

[0058] FIG. 27 illustrates CART, PAM, and random forests classification algorithm (decision rule) performance data, and associated 95% confidence intervals, using T_{-12} baseline data obtained from a training population in accordance with an embodiment of the present invention.

[0059] FIG. 28 illustrates the number of times that common biomarkers were found to be important across the decision rules developed using (i) CART, (ii) PAM, (iii) random forests, and (iv) the Wilcoxon (adjusted) test using T_{-12} baseline data obtained from a training population.

[0060] FIG. 29 illustrates an overall ranking of biomarkers for data obtained using T_{-12} baseline data obtained from a training population. The biomarkers are referenced by their corresponding Affymetrix U133 plus 2.0 probeset names given in Table 30.

[0061] FIG. 30 illustrates the filters applied to identify biomarkers that discriminate between subjects that will get sepsis during a defined time period and subjects that will not get sepsis during the defined time period using data obtained from a training population, in accordance with an embodiment of the present invention. Other combinations of biomarkers are disclosed herein including, for example, in Section 5.3 and in Section 6.

[0062] FIG. 31 shows the correlation between IL18R1 expression, as determined by RT-PCR, and the intensity of the

X206618_at probeset, as determined using Affymetrix U133 plus 2.0 microarray measurements, across a training population.

[0063] FIG. 32 shows the correlation between FCGR1A expression, as determined by RT-PCR, and the intensity of the X214511_x_at, X216950_s_at and X216951_at probesets, as determined using Affymetrix U133 plus 2.0 microarray measurements, across a training population.

[0064] FIG. 33 shows the correlation between MMP9 expression, as determined by RT-PCR, and the intensity of the X203936_s_at probeset, as determined using Affymetrix U133 plus 2.0 microarray measurements, across a training population.

[0065] FIG. 34 shows the correlation between CD86 expression, as determined by RT-PCR, and the intensity of the X205685_at, X205686_s_at, and X210895_s_at probesets, as determined using Affymetrix U133 plus 2.0 microarray measurements, across a training population.

[0066] FIG. 35 shows a computer system in accordance with the present invention.

[0067] FIG. 36 illustrates a classification and regression tree for discriminating between a SIRS phenotypic state characterized by the onset of sepsis and a SIRS phenotypic state characterized by the absence of sepsis using T_{-12} static data obtained from an RT-PCR discovery training population in accordance with an embodiment of the present invention.

[0068] FIG. 37 shows the distribution of feature values for seven biomarkers used in the decision tree of FIG. 36 across T_{-12} static data obtained from an RT-PCR discovery training population in accordance with an embodiment of the present invention.

[0069] FIG. 38 illustrates the overall accuracy, sensitivity, and specificity of 462 trees used to train a decision tree using the Random Forests method based upon T_{-12} static data obtained from an RT-PCR discovery training population in accordance with an embodiment of the present invention.

[0070] FIG. 39 illustrates the biomarker importance in the decision rule trained using the trees of FIG. 38.

[0071] FIG. 40 illustrates a calculation of biomarker importance, summing to 100%, determined by a multiple additive regression tree (MART) approach using T_{-12} static data obtained from an RT-PCR discovery training population.

[0072] FIG. 41 illustrates the distribution of feature values of the biomarkers selected by the MART approach illustrated in FIG. 40 between the Sepsis and SIRS groups using T_{-12} static data obtained from an RT-PCR discovery training population.

[0073] FIG. 42 illustrates the overall accuracy, with 95% confidence interval bars, specificity, and sensitivity of a decision rule developed with predictive analysis of microarrays (PAM) using the biomarkers of the present invention using T_{-12} static data obtained from an RT-PCR discovery training population.

[0074] FIG. 43 is a list of biomarkers, rank-ordered by their respective degrees of discriminatory power, identified by PAM using T_{-12} static data obtained from an RT-PCR discovery training population.

[0075] FIG. 44 provides a summary of the CART, MART, PAM, and random forests (RF) classification algorithm (decision rule) performance and associated 95% confidence intervals using T_{-12} static data obtained from an RT-PCR discovery training population.

[0076] FIG. 45 identified fifty selected biomarkers selected based on the decision rule performance summarized in FIG. 44.

[0077] FIG. 46 provides a summary of the CART, MART, PAM, and random forests (RF) classification algorithm (decision rule) performance and associated 95% confidence intervals using T_{-12} static data obtained from an Affymetrix gene chip discovery training population.

[0078] FIG. 47 provides a summary of the CART, MART, PAM, and random forests (RF) classification algorithm (decision rule) performance and associated 95% confidence intervals using T_{-12} static data obtained from an RT-PCR confirmatory training population.

[0079] FIG. 48 provides a summary of the CART, MART, PAM, and random forests (RF) classification algorithm (decision rule) performance and associated 95% confidence intervals using T_{-12} static data obtained from a combined pool of an Affymetrix gene chip confirmatory training population and an RT-PCR confirmatory training population.

[0080] FIG. 49 illustrates a classification and regression tree for discriminating between a SIRS phenotypic state characterized by the onset of sepsis and a SIRS phenotypic state characterized by the absence of sepsis using T_{-12} static data obtained from a bead-based protein discovery training population in accordance with an embodiment of the present invention.

[0081] FIG. 50 shows the distribution of feature values for ten biomarkers used in the decision tree of FIG. 49 across T_{-12} static data obtained from a bead-based protein discovery training population in accordance with an embodiment of the present invention.

[0082] FIG. 51 illustrates the overall accuracy, sensitivity, and specificity of 64 trees used to train a decision tree using the Random Forests method based upon T_{-12} static data obtained from a bead-based protein discovery training population in accordance with an embodiment of the present invention.

[0083] FIG. 52 illustrates the biomarker importance in the decision rule trained using the trees of FIG. 51.

[0084] FIG. 53 illustrates a calculation of biomarker importance, summing to 100%, determined by a multiple additive regression tree (MART) approach using T_{-12} static data obtained from a bead-based protein discovery training population in accordance with an embodiment of the present invention.

[0085] FIG. 54 illustrates the distribution of feature values of the biomarkers selected by the MART approach illustrated in FIG. 53 between the Sepsis and SIRS groups using T_{-12} static data obtained from a bead-based protein discovery training population in accordance with an embodiment of the present invention.

[0086] FIG. 55 illustrates the overall accuracy, with 95% confidence interval bars, specificity, and sensitivity of a decision rule developed with predictive analysis of microarrays (PAM) using the biomarkers of the present invention using T_{-12} static data obtained from a bead-based protein discovery training population in accordance with an embodiment of the present invention.

[0087] FIG. 56 is a list of biomarkers, rank-ordered by their respective degrees of discriminatory power, identified by PAM using T_{-12} static data obtained from a bead-based protein discovery training population in accordance with an embodiment of the present invention.

[0088] FIG. 57 provides a summary of the CART, MART, PAM, and random forests (RF) classification algorithm (decision rule) performance and associated 95% confidence intervals using T_{-12} static data obtained from a bead-based protein discovery training population in accordance with an embodiment of the present invention.

[0089] FIG. 58 illustrates the number of times that common biomarkers were found to be important across the decision rules developed using (i) CART, (ii) MART, (iii) PAM, (iv) random forests, and (v) the Wilcoxon (adjusted) test using T_{-12} static data obtained from a bead-based protein discovery training population in accordance with an embodiment of the present invention.

[0090] FIG. 59 provides a summary of the CART, MART, PAM, and random forests (RF) classification algorithm (decision rule) performance and associated 95% confidence intervals using T_{-12} static data obtained from a bead-based protein confirmation training population in accordance with an embodiment of the present invention.

[0091] FIG. 60 plots the sepsis predicting accuracy of each of 24 families of subcombinations from Table J, using T_{-12} nucleic acid data, in a bar graph fashion, in accordance with an embodiment of the present invention.

[0092] FIG. 61 plots the sepsis predicting performance (accuracy) of each individual subcombination in each of 24 families of subcombinations, for a total of 4800 subcombinations from Table J, using T_{-12} nucleic acid data, in accordance with an embodiment of the present invention.

[0093] FIG. 62 plots the sepsis predicting accuracy of each of 8 families of subcombinations from Table K, using T_{-12} protein data, in a bar graph fashion, in accordance with an embodiment of the present invention.

[0094] FIG. 63 plots the sepsis predicting performance (accuracy) of each individual subcombination in each of 8 families of subcombinations, for a total of 1600 subcombinations from Table K, using T_{-12} protein data, in accordance with an embodiment of the present invention.

[0095] FIG. 64 plots the sepsis predicting accuracy of each of 8 families of subcombinations from Table K, using T_{-36} protein data, in a bar graph fashion, in accordance with an embodiment of the present invention.

[0096] FIG. 65 plots the sepsis predicting performance (accuracy) of each individual subcombination in each of 8 families of subcombinations, for a total of 1600 subcombinations from Table K, using T_{-36} protein data, in accordance with an embodiment of the present invention.

[0097] FIG. 66 plots the sepsis predicting accuracy of each of 23 families of subcombinations from Table J, using T_{-36} nucleic acid data, in a bar graph fashion, in accordance with an embodiment of the present invention.

[0098] FIG. 67 plots the sepsis predicting performance (accuracy) of each individual subcombination in each of 23 families of subcombinations, for a total of 4600 subcombinations from Table J, using T_{-36} nucleic acid data, in accordance with an embodiment of the present invention.

[0099] FIG. 68 plots the sepsis predicting accuracy of each of 23 families of subcombinations from Table I, using T_{-12} combined protein and nucleic acid data, in a bar graph fashion, in accordance with an embodiment of the present invention.

[0100] FIG. 69 plots the sepsis predicting performance (accuracy) of each individual subcombination in each of 23 families of subcombinations, for a total of 4600 subcombina-

tions from Table I, using T_{-12} combined protein and nucleic acid data, in accordance with an embodiment of the present invention.

[0101] FIG. 70 plots the sepsis predicting accuracy of each of 23 families of subcombinations from Table I, using T_{-36} combined protein and nucleic acid data, in a bar graph fashion, in accordance with an embodiment of the present invention.

[0102] FIG. 71 plots the sepsis predicting performance (accuracy) of each individual subcombination in each of 23 families of subcombinations, for a total of 4600 subcombinations from Table I, using T_{-36} combined protein and nucleic acid data, in accordance with an embodiment of the present invention.

5. DETAILED DESCRIPTION OF THE PREFERRED EMBODIMENTS

[0103] The present invention allows for the rapid and accurate diagnosis or prediction of sepsis by evaluating biomarker features in biomarker profiles. These biomarker profiles can be constructed from one or more biological samples of subjects at a single time point (“snapshot”), or multiple such time points, during the course of time the subject is at risk for developing sepsis. Advantageously, sepsis can be diagnosed or predicted prior to the onset of conventional clinical sepsis symptoms, thereby allowing for more effective therapeutic intervention.

5.1 DEFINITIONS

[0104] “Systemic inflammatory response syndrome,” or “SIRS,” refers to a clinical response to a variety of severe clinical insults, as manifested by two or more of the following conditions within a 24-hour period:

[0105] body temperature greater than 38° C. (100.4° F.) or less than 36° C. (96.8° F.);

[0106] heart rate (HR) greater than 90 beats/minute;

[0107] respiratory rate (RR) greater than 20 breaths/minute, or P_{CO_2} less than 32 mmHg, or requiring mechanical ventilation; and

[0108] white blood cell count (WBC) either greater than $12.0 \times 10^9/L$ or less than $4.0 \times 10^9/L$.

[0109] These symptoms of SIRS represent a consensus definition of SIRS that can be modified or supplanted by other definitions in the future. The present definition is used to clarify current clinical practice and does not represent a critical aspect of the invention (see, e.g., American College of Chest Physicians/Society of Critical Care Medicine Consensus Conference: Definitions for Sepsis and Organ Failure and Guidelines for the Use of Innovative Therapies in Sepsis, 1992, *Crit. Care. Med.* 20, 864-874, the entire contents of which are herein incorporated by reference).

[0110] A subject with SIRS has a clinical presentation that is classified as SIRS, as defined above, but is not clinically deemed to be septic. Methods for determining which subjects are at risk of developing sepsis are well known to those in the art. Such subjects include, for example, those in an ICU and those who have otherwise suffered from a physiological trauma, such as a burn, surgery or other insult. A hallmark of SIRS is the creation of a proinflammatory state that can be marked by tachycardia, tachypnea or hyperpnea, hypotension, hypoperfusion, oliguria, leukocytosis or leukopenia, pyrexia or hypothermia and the need for volume infusion.

SIRS characteristically does not include a documented source of infection (e.g., bacteremia).

[0111] “Sepsis” refers to a systemic host response to infection with SIRS plus a documented infection (e.g., a subsequent laboratory confirmation of a clinically significant infection such as a positive culture for an organism). Thus, sepsis refers to the systemic inflammatory response to a documented infection (see, e.g., American College of Chest Physicians Society of Critical Care Medicine, Chest, 1997, 101:1644-1655, the entire contents of which are herein incorporated by reference). As used herein, “sepsis” includes all stages of sepsis including, but not limited to, the onset of sepsis, severe sepsis, septic shock and multiple organ dysfunction (“MOD”) associated with the end stages of sepsis.

[0112] The “onset of sepsis” refers to an early stage of sepsis, e.g., prior to a stage when conventional clinical manifestations are sufficient to support a clinical suspicion of sepsis. Because the methods of the present invention are used to detect sepsis prior to a time that sepsis would be suspected using conventional techniques, the subject’s disease status at early sepsis can only be confirmed retrospectively, when the manifestation of sepsis is more clinically obvious. The exact mechanism by which a subject becomes septic is not a critical aspect of the invention. The methods of the present invention can detect the onset of sepsis independent of the origin of the infectious process.

[0113] “Severe sepsis” refers to sepsis associated with organ dysfunction, hypoperfusion abnormalities, or sepsis-induced hypotension. Hypoperfusion abnormalities include, but are not limited to, lactic acidosis, oliguria, or an acute alteration in mental status.

[0114] “Septic shock” refers to sepsis-induced hypotension that is not responsive to adequate intravenous fluid challenge and with manifestations of peripheral hypoperfusion.

[0115] A “converter” or “converter subject” refers to a SIRS-positive subject who progresses to clinical suspicion of sepsis during the period the subject is monitored, typically during an ICU stay.

[0116] A “non-converter” or “non-converter subject” refers to a SIRS-positive subject who does not progress to clinical suspicion of sepsis during the period the subject is monitored, typically during an ICU stay.

[0117] A “biomarker” is virtually any detectable compound, such as a protein, a peptide, a proteoglycan, a glycoprotein, a lipoprotein, a carbohydrate, a lipid, a nucleic acid (e.g., DNA, such as cDNA or amplified DNA, or RNA, such as mRNA), an organic or inorganic chemical, a natural or synthetic polymer, a small molecule (e.g., a metabolite), or a discriminating molecule or discriminating fragment of any of the foregoing, that is present in or derived from a biological sample. “Derived from” as used in this context refers to a compound that, when detected, is indicative of a particular molecule being present in the biological sample. For example, detection of a particular cDNA can be indicative of the presence of a particular RNA transcript in the biological sample. As another example, detection of or binding to a particular antibody can be indicative of the presence of a particular antigen (e.g., protein) in the biological sample. Here, a discriminating molecule or fragment is a molecule or fragment that, when detected, indicates presence or abundance of an above-identified compound.

[0118] A biomarker can, for example, be isolated from the biological sample, directly measured in the biological sample, or detected in or determined to be in the biological

sample. A biomarker can, for example, be functional, partially functional, or non-functional. In one embodiment of the present invention, a biomarker is isolated and used, for example, to raise a specifically-binding antibody that can facilitate biomarker detection in a variety of diagnostic assays. Any immunoassay may use any antibodies, antibody fragment or derivative thereof capable of binding the biomarker molecules (e.g., Fab, F(ab’)₂, Fv, or scFv fragments). Such immunoassays are well-known in the art. In addition, if the biomarker is a protein or fragment thereof, it can be sequenced and its encoding gene can be cloned using well-established techniques.

[0119] As used herein, the term “a species of a biomarker” refers to any discriminating portion or discriminating fragment of a biomarker described herein, such as a splice variant of a particular gene described herein (e.g., a gene listed in Table 30, or Table I, or Table J, or Table K, *infra*). Here, a discriminating portion or discriminating fragment is a portion or fragment of a molecule that, when detected, indicates presence or abundance of the above-identified transcript, cDNA, amplified nucleic acid, or protein.

[0120] As used herein, the terms “protein”, “peptide”, and “polypeptide” are, unless otherwise indicated, interchangeable.

[0121] A “biomarker profile” comprises a plurality of one or more types of biomarkers (e.g., an mRNA molecule, a cDNA molecule, a protein and/or a carbohydrate, etc.), or an indication thereof, together with a feature, such as a measurable aspect (e.g., abundance) of the biomarkers. A biomarker profile comprises at least two such biomarkers or indications thereof, where the biomarkers can be in the same or different classes, such as, for example, a nucleic acid and a carbohydrate. A biomarker profile may also comprise at least 3, 4, 5, 6, 7, 8, 9, 10, 11, 12, 13, 14, 15, 16, 17, 18, 19, 20, 21, 22, 23, 24, 25, 30, 35, 40, 45, 50, 55, 60, 65, 70, 75, 80, 85, 90, 95, or 100 or more biomarkers or indications thereof. In one embodiment, a biomarker profile comprises hundreds, or even thousands, of biomarkers or indications thereof. A biomarker profile can further comprise one or more controls or internal standards. In one embodiment, the biomarker profile comprises at least one biomarker, or indication thereof, that serves as an internal standard. In another embodiment, a biomarker profile comprises an indication of one or more types of biomarkers. The term “indication” as used herein in this context merely refers to a situation where the biomarker profile contains symbols, data, abbreviations or other similar indicia for a biomarker, rather than the biomarker molecular entity itself. For instance, consider an exemplary biomarker profile of the present invention that comprises the Affymetrix (Santa Clara, Calif.) U133 plus 2.0 205013_s_at and 209369_at probesets. Another exemplary biomarker profile of the present invention comprises the name of genes used to derive the Affymetrix (Santa Clara, Calif.) U133 plus 2.0 205013_s_at and 209369_at probesets. In still another exemplary biomarker profile of the present invention, the biomarker profile comprises a physical quantity of a transcript of a gene from which the 205013_s_at probeset was derived, and a physical quantity of a transcript of a gene from which the 209369_at probeset was derived. In another embodiment, the biomarker profile comprises a nominal indication of the quantity of a transcript of a gene from which the 205013_s_at probeset was derived and a nominal indication of the quantity of transcript of a gene from which the 209369_at probeset was derived. Still another exemplary biomarker profile of the

present invention comprises a microarray to which a physical quantity of a gene transcript from which the 205013_s_at probeset was derived is bound at a first probe spot on the microarray and an abundance of a gene transcript from which the 209369_at probeset was derived is bound to a second probe spot on the microarray. In this last exemplary biomarker profile, at least twenty percent, forty percent, or more than forty percent of the probes spots are based on sequences in the probesets given in Table 30. In another exemplary biomarker profile, at least twenty percent, forty percent, or more than forty percent of the probes spots are based on sequences in the probesets given in Table 31.

[0122] Each biomarker in a biomarker profile includes a corresponding “feature.” A “feature”, as used herein, refers to a measurable aspect of a biomarker. A feature can include, for example, the presence or absence of biomarkers in the biological sample from the subject as illustrated in exemplary biomarker profile 1:

Exemplary biomarker profile 1.	
Biomarker	Feature Presence in sample
transcript of gene A	Present
transcript of gene B	Absent

[0123] In exemplary biomarker profile 1, the feature value for the transcript of gene A is “presence” and the feature value for the transcript of gene B is “absence.”

[0124] A feature can include, for example, the abundance of a biomarker in the biological sample from a subject as illustrated in exemplary biomarker profile 2:

Exemplary biomarker profile 2.	
Biomarker	Feature Abundance in sample in relative units
transcript of gene A	300
transcript of gene B	400

[0125] In exemplary biomarker profile 2, the feature value for the transcript of gene A is 300 units and the feature value for the transcript of gene B is 400 units.

[0126] A feature can also be a ratio of two or more measurable aspects of a biomarker as illustrated in exemplary biomarker profile 3:

Exemplary biomarker profile 3.	
Biomarker	Feature Ratio of abundance of transcript of gene A/transcript of gene B
transcript of gene A transcript of gene B	300/400

[0127] In exemplary biomarker profile 3, the feature value for the transcript of gene A and the feature value for the transcript of gene B is 0.75 (300/400).

[0128] A feature may also be the difference between a measurable aspect of the corresponding biomarker that is taken from two samples, where the two samples are collected from a subject at two different time points. For example, consider the case where the biomarker is a transcript of a gene A and the “measurable aspect” is abundance of the transcript, in samples obtained from a test subject as determined by, e.g., RT-PCR or microarray analysis. In this example, the abundance of the transcript of gene A is measured in a first sample as well as a second sample. The first sample is taken from the test subject a number of hours before the second sample. To compute the feature for gene A, the abundance of the transcript of gene A in one sample is subtracted from the abundance of the transcript of gene A in the second sample. A feature can also be an indication as to whether an abundance of a biomarker is increasing in biological samples obtained from a subject over time and/or an indication as to whether an abundance of a biomarker is decreasing in biological samples obtained from a subject over time.

[0129] In some embodiments, there is a one-to-one correspondence between features and biomarkers in a biomarker profile as illustrated in exemplary biomarker profile 1, above. In some embodiments, the relationship between features and biomarkers in a biomarker profile of the present invention is more complex, as illustrated in Exemplary biomarker profile 3, above.

[0130] Those of skill in the art will appreciate that other methods of computation of a feature can be devised and all such methods are within the scope of the present invention. For example, a feature can represent the average of an abundance of a biomarker across biological samples collected from a subject at two or more time points. Furthermore, a feature can be the difference or ratio of the abundance of two or more biomarkers from a biological sample obtained from a subject in a single time point. A biomarker profile may also comprise at least three, four, five, 10, 20, 30 or more features. In one embodiment, a biomarker profile comprises hundreds, or even thousands, of features.

[0131] In some embodiments, features of biomarkers are measured using microarrays. The construction of microarrays and the techniques used to process microarrays in order to obtain abundance data is well known, and is described, for example, by Draghici, 2003, *Data Analysis Tools for DNA Microarrays*, Chapman & Hall/CRC, and international publication number WO 03/061564, each of which is hereby incorporated by reference in its entirety. A microarray comprises a plurality of probes. In some instances, each probe recognizes, e.g., binds to, a different biomarker. In some instances, two or more different probes on a microarray recognize, e.g., bind to, the same biomarker. Thus, typically, the relationship between probe spots on the microarray and a subject biomarker is a two to one correspondence, a three to one correspondence, or some other form of correspondence. However, it can be the case that there is a unique one-to-one correspondence between probes on a microarray and biomarkers.

[0132] A “phenotypic change” is a detectable change in a parameter associated with a given state of the subject. For instance, a phenotypic change can include an increase or decrease of a biomarker in a bodily fluid, where the change is associated with SIRS, sepsis, the onset of sepsis or with a particular stage in the progression of sepsis. A phenotypic change can further include a change in a detectable aspect of a given state of the subject that is not a change in a measurable

aspect of a biomarker. For example, a change in phenotype can include a detectable change in body temperature, respiration rate, pulse, blood pressure, or other physiological parameter. Such changes can be determined via clinical observation and measurement using conventional techniques that are well-known to the skilled artisan.

[0133] As used herein, the term “complementary,” in the context of a nucleic acid sequence (e.g., a nucleotide sequence encoding a gene described herein), refers to the chemical affinity between specific nitrogenous bases as a result of their hydrogen bonding properties. For example, guanine (G) forms a hydrogen bond with only cytosine (C), while adenine forms a hydrogen bond only with thymine (T) in the case of DNA, and uracil (U) in the case of RNA. These reactions are described as base pairing, and the paired bases (G with C, or A with T/U) are said to be complementary. Thus, two nucleic acid sequences may be complementary if their nitrogenous bases are able to form hydrogen bonds. Such sequences are referred to as “complements” of each other. Such complement sequences can be naturally occurring, or, they can be chemically synthesized by any method known to those skilled in the art, as for example, in the case of antisense nucleic acid molecules which are complementary to the sense strand of a DNA molecule or an RNA molecule (e.g., an mRNA transcript). See, e.g., Lewin, 2002, *Genes VII*. Oxford University Press Inc., New York, N.Y., which is hereby incorporated by reference.

[0134] As used herein, “conventional techniques” in the context of diagnosing or predicting sepsis or SIRS are those techniques that classify a subject based on phenotypic changes without obtaining a biomarker profile according to the present invention.

[0135] A “decision rule” is a method used to evaluate biomarker profiles. Such decision rules can take on one or more forms that are known in the art, as exemplified in Hastie et al., 2001, *The Elements of Statistical Learning*, Springer-Verlag, New York, which is hereby incorporated by reference in its entirety. A decision rule may be used to act on a data set of features to, inter alia, predict the onset of sepsis, to determine the progression of sepsis, or to diagnose sepsis. Exemplary decision rules that can be used in some embodiments of the present invention are described in further detail in Section 5.5, below.

[0136] “Predicting the development of sepsis” is the determination as to whether a subject will develop sepsis. Any such prediction is limited by the accuracy of the means used to make this determination. The present invention provides a method, e.g., by utilizing a decision rule(s), for making this determination with an accuracy that is 60% or greater. As used herein, the terms “predicting the development of sepsis” and “predicting sepsis” are interchangeable. In some embodiments, the act of predicting the development of sepsis (predicting sepsis) is accomplished by evaluating one or more biomarker profiles from a subject using a decision rule that is indicative of the development of sepsis and, as a result of this evaluation, receiving a result from the decision rule that indicates that the subject will become septic. Such an evaluation of one or more biomarker profiles from a test subject using a decision rule uses some or all the features in the one or more biomarker profiles to obtain such a result.

[0137] The terms “obtain” and “obtaining,” as used herein, mean “to come into possession of,” or “coming into possession of,” respectively. This can be done, for example, by

retrieving data from a data store in a computer system. This can also be done, for example, by direct measurement.

[0138] As used herein, the term “specifically,” and analogous terms, in the context of an antibody, refers to peptides, polypeptides, and antibodies or fragments thereof that specifically bind to an antigen or a fragment and do not specifically bind to other antigens or other fragments. A peptide or polypeptide that specifically binds to an antigen may bind to other peptides or polypeptides with lower affinity, as determined by standard experimental techniques, for example, by any immunoassay well-known to those skilled in the art. Such immunoassays include, but are not limited to, radioimmunoassays (RIAs) and enzyme-linked immunosorbent assays (ELISAs). Antibodies or fragments that specifically bind to an antigen may be cross-reactive with related antigens. Preferably, antibodies or fragments thereof that specifically bind to an antigen do not cross-react with other antigens. See, e.g., Paul, ed., 2003, *Fundamental Immunology*, 5th ed., Raven Press, New York at pages 69-105, which is incorporated by reference herein, for a discussion regarding antigen-antibody interactions, specificity and cross-reactivity, and methods for determining all of the above.

[0139] As used herein, a “subject” is an animal, preferably a mammal, more preferably a non-human primate, and most preferably a human. The terms “subject” “individual” and “patient” are used interchangeably herein.

[0140] As used herein, a “test subject,” typically, is any subject that is not in a training population used to construct a decision rule. A test subject can optionally be suspected of either having sepsis at risk of developing sepsis.

[0141] As used herein, a “tissue type,” is a type of tissue. A tissue is an association of cells of a multicellular organism, with a common embryological origin or pathway and similar structure and function. Often, cells of a tissue are contiguous at cell membranes but occasionally the tissue may be fluid (e.g., blood). Cells of a tissue may be all of one type (a simple tissue, e.g., squamous epithelium, plant parenchyma) or of more than one type (a mixed tissue, e.g., connective tissue).

[0142] As used herein, a “training population” is a set of samples from a population of subjects used to construct a decision rule, using a data analysis algorithm, for evaluation of the biomarker profiles of subjects at risk for developing sepsis. In a preferred embodiment, a training population includes samples from subjects that are converters and subjects that are nonconverters.

[0143] As used herein, a “data analysis algorithm” is an algorithm used to construct a decision rule using biomarker profiles of subjects in a training population. Representative data analysis algorithms are described in Section 5.5. A “decision rule” is the final product of a data analysis algorithm, and is characterized by one or more value sets, where each of these value sets is indicative of an aspect of SIRS, the onset of sepsis, sepsis, or a prediction that a subject will acquire sepsis. In one specific example, a value set represents a prediction that a subject will develop sepsis. In another example, a value set represents a prediction that a subject will not develop sepsis.

[0144] As used herein, a “validation population” is a set of samples from a population of subjects used to determine the accuracy of a decision rule. In a preferred embodiment, a validation population includes samples from subjects that are converters and subjects that are nonconverters. In a preferred embodiment, a validation population does not include sub-

jects that are part of the training population used to train the decision rule for which an accuracy measurement is sought.

[0145] As used herein, a “value set” is a combination of values, or ranges of values for features in a biomarker profile. The nature of this value set and the values therein is dependent upon the type of features present in the biomarker profile and the data analysis algorithm used to construct the decision rule that dictates the value set. To illustrate, reconsider exemplary biomarker profile 2:

Exemplary biomarker profile 2.	
Biomarker	Feature Abundance in sample in relative units
transcript of gene A	300
transcript of gene B	400

[0146] In this example, the biomarker profile of each member of a training population is obtained. Each such biomarker profile includes a measured feature, here abundance, for the transcript of gene A, and a measured feature, here abundance, for the transcript of gene B. These feature values, here abundance values, are used by a data analysis algorithm to construct a decision rule. In this example, the data analysis algorithm is a decision tree, described in Section 5.5.1 and the final product of this data analysis algorithm, the decision rule, is a decision tree. An exemplary decision tree is illustrated in FIG. 1. The decision rule defines value sets. One such value set is predictive of the onset of sepsis. A subject whose biomarker feature values satisfy this value set is likely to become septic. An exemplary value set of this class is exemplary value set 1:

Exemplary value set 1.	
Biomarker	Value set component (Abundance in sample in relative units)
transcript of gene A	<400
transcript of gene B	<600

[0147] Another such value set is predictive of a septic-free state. A subject whose biomarker feature values satisfy this value set is not likely to become septic. An exemplary value set of this class is exemplary value set 2:

Exemplary value set 2.	
Biomarker	Value set component (Abundance in sample in relative units)
transcript of gene A	>400
transcript of gene B	>600

[0148] In the case where the data analysis algorithm is a neural network analysis and the final product of this neural network analysis is an appropriately weighted neural network, one value set is those ranges of biomarker profile fea-

ture values that will cause the weighted neural network to indicate that onset of sepsis is likely. Another value set is those ranges of biomarker profile feature values that will cause the weighted neural network to indicate that onset of sepsis is not likely.

[0149] As used herein, the term “probe spot” in the context of a microarray refers to a single stranded DNA molecule (e.g., a single stranded cDNA molecule or synthetic DNA oligomer), referred to herein as a “probe,” that is used to determine the abundance of a particular nucleic acid in a sample. For example, a probe spot can be used to determine the level of mRNA in a biological sample (e.g., a collection of cells) from a test subject. In a specific embodiment, a typical microarray comprises multiple probe spots that are placed onto a glass slide (or other substrate) in known locations on a grid. The nucleic acid for each probe spot is a single stranded contiguous portion of the sequence of a gene or gene of interest (e.g., a 10-mer, 11-mer, 12-mer, 13-mer, 14-mer, 15-mer, 16-mer, 17-mer, 18-mer, 19-mer, 20-mer, 21-mer, 22-mer, 23-mer, 24-mer, 25-mer or larger) and is a probe for the mRNA encoded by the particular gene or gene of interest. Each probe spot is characterized by a single nucleic acid sequence, and is hybridized under conditions that cause it to hybridize only to its complementary DNA strand or mRNA molecule. As such, there can be many probe spots on a substrate, and each can represent a unique gene or sequence of interest. In addition, two or more probe spots can represent the same gene sequence. In some embodiments, a labeled nucleic sample is hybridized to a probe spot, and the amount of labeled nucleic acid specifically hybridized to a probe spot can be quantified to determine the levels of that specific nucleic acid (e.g., mRNA transcript of a particular gene) in a particular biological sample. Probes, probe spots, and microarrays, generally, are described in Draghici, 2003, *Data Analysis Tools for DNA Microarrays*, Chapman & Hall/CRC, Chapter, 2, which is hereby incorporated by reference in its entirety.

[0150] As used herein, the term “annotation data” refers to any type of data that describes a property of a biomarker. Annotation data includes, but is not limited to, biological pathway membership, enzymatic class (e.g., phosphodiesterase, kinase, metalloproteinase, etc.), protein domain information, enzymatic substrate information, enzymatic reaction information, protein interaction data, disease association, cellular localization, tissue type localization, and cell type localization.

[0151] As used herein, the term “ T_{-12} ” refers to the last time blood was obtained from a subject before the subject is clinically diagnosed with sepsis. Since, in the present invention, blood is collected from subjects each 24 hour period, T_{-12} references the average time period prior to the onset of sepsis for a pool of patients, with some patients turning septic prior to the 12 hour mark and some patients turning septic after the 12 hour mark. However, across a pool of subjects, the average time period for this last blood sample is the 12 hour mark, hence the name “ T_{-12} .”

5.2 METHODS FOR SCREENING SUBJECTS

[0152] The present invention allows for accurate, rapid prediction and/or diagnosis of sepsis through detection of two or more features of a biomarker profile of a test individual suspected of or at risk for developing sepsis in each of one or more biological samples from a test subject. In one embodiment, only a single biological sample taken at a single point in

time from the test subject is needed to construct a biomarker profile that is used to make this prediction or diagnosis of sepsis. In another embodiment, multiple biological samples taken at different points in time from the test subject are used to construct a biomarker profile that is used to make this prediction or diagnosis of sepsis.

[0153] In specific embodiments of the invention, subjects at risk for developing sepsis or SIRS are screened using the methods of the present invention. In accordance with these embodiments, the methods of the present invention can be employed to screen, for example, subjects admitted to an ICU and/or those who have experienced some sort of trauma (such as, e.g., surgery, vehicular accident, gunshot wound, etc.).

[0154] In specific embodiments, a biological sample such as, for example, blood, is taken upon admission. In some embodiments, a biological sample is blood, plasma, serum, saliva, sputum, urine, cerebral spinal fluid, cells, a cellular extract, a tissue specimen, a tissue biopsy, or a stool specimen. In some embodiments a biological sample is whole blood and this whole blood is used to obtain measurements for a biomarker profile. In some embodiments a biological sample is some component of whole blood. For example, in some embodiments some portion of the mixture of proteins, nucleic acid, and/or other molecules (e.g., metabolites) within a cellular fraction or within a liquid (e.g., plasma or serum fraction) of the blood is resolved as a biomarker profile. This can be accomplished by measuring features of the biomarkers in the biomarker profile. In some embodiments, the biological sample is whole blood but the biomarker profile is resolved from biomarkers in a specific cell type that is isolated from the whole blood. In some embodiments, the biological sample is whole blood but the biomarker profile is resolved from biomarkers expressed or otherwise found in monocytes that are isolated from the whole blood. In some embodiments, the biological sample is whole blood but the biomarker profile is resolved from biomarkers expressed or otherwise found in red blood cells that are isolated from the whole blood. In some embodiments, the biological sample is whole blood but the biomarker profile is resolved from biomarkers expressed or otherwise found in platelets that are isolated from the whole blood. In some embodiments, the biological sample is whole blood but the biomarker profile is resolved from biomarkers expressed or otherwise found in neutrophils that are isolated from the whole blood. In some embodiments, the biological sample is whole blood but the biomarker profile is resolved from biomarkers expressed or otherwise found in eosinophils that are isolated from the whole blood. In some embodiments, the biological sample is whole blood but the biomarker profile is resolved from biomarkers expressed or otherwise found in basophils that are isolated from the whole blood. In some embodiments, the biological sample is whole blood but the biomarker profile is resolved from biomarkers expressed or otherwise found in lymphocytes that are isolated from the whole blood. In some embodiments, the biological sample is whole blood but the biomarker profile is resolved from biomarkers expressed or otherwise found in monocytes that are isolated from the whole blood. In some embodiments, the biological sample is whole blood but the biomarker profile is resolved from one, two, three, four, five, six, or seven cell types from the group of cells types consisting of red blood cells, platelets, neutrophils, eosinophils, basophils, lymphocytes, and monocytes.

[0155] A biomarker profile comprises a plurality of one or more types of biomarkers (e.g., an mRNA molecule, a cDNA

molecule, a protein and/or a carbohydrate, etc.), or an indication thereof, together with features, such as a measurable aspect (e.g., abundance) of the biomarkers. A biomarker profile can comprise at least two such biomarkers or indications thereof, where the biomarkers can be in the same or different classes, such as, for example, a nucleic acid and a carbohydrate. In some embodiments, a biomarker profile comprises at least 2, 3, 4, 5, 6, 7, 8, 9, 10, 11, 12, 13, 14, 15, 16, 17, 18, 19, 20, 25, 30, 35, 40, 45, 50, 55, 60, 65, 70, 75, 80, 85, 90, 95, 96, 100, 105, 110, 115, 120, 125, 130, 135, 140, 145, 150, 155, 160, 165, 170, 175, 180, 185, 190, 195 or 200 or more biomarkers or indications thereof. In one embodiment, a biomarker profile comprises hundreds, or even thousands, of biomarkers or indications thereof. In some embodiments, a biomarker profile comprises at least 2, 3, 4, 5, 6, 7, 8, 9, 10, 11, 12, 13, 14, 15, 16, 17, 18, 19, 20, 25, 30, 35, 40, 45, 50, or more biomarkers or indications thereof. In one example, in some embodiments, a biomarker profile comprises at least 2, 3, 4, 5, 6, 7, 8, 9, 10, 11, 12, 13, 14, 15, 16, 17, 18, 19, 20, 25, 30, 35, 40, 45, 50, or more biomarkers selected from Table I of Section 5.11, or indications thereof. In another example, in some embodiments, a biomarker profile comprises at least 2, 3, 4, 5, 6, 7, 8, 9, 10, 11, 12, 13, 14, 15, 16, 17, 18, 19, 20, 25, 30, 35, 40 or more biomarkers selected from Table J of Section 5.11, or indications thereof. In another example, in some embodiments, a biomarker profile comprises any 2, 3, 4, 5, 6, 7, 8, 9, or all ten biomarkers in Table K of Section 5.11, or indications thereof.

[0156] In typical embodiments, each biomarker in the biomarker profile is represented by a feature. In other words, there is a correspondence between biomarkers and features. In some embodiments, the correspondence between biomarkers and features is 1:1, meaning that for each biomarker there is a feature. In some embodiments, there is more than one feature for each biomarker. In some embodiments the number of features corresponding to one biomarker in the biomarker profile is different than then number of features corresponding to another biomarker in the biomarker profile. As such, in some embodiments, a biomarker profile can include at least 2, 3, 4, 5, 6, 7, 8, 9, 10, 11, 12, 13, 14, 15, 16, 17, 18, 19, 20, 25, 30, 35, 40, 45, 50, 55, 60, 65, 70, 75, 80, 85, 90, 95, 96, 100, 105, 110, 115, 120, 125, 130, 135, 140, 145, 150, 155, 160, 165, 170, 175, 180, 185, 190, 195 or 200 or more features, provided that there are at least 2, 3, 4, 5, 6, or 7 or more biomarkers in the biomarker profile. In some embodiments, a biomarker profile can include at least 2, 3, 4, 5, 6, 7, 8, 9, 10, 11, 12, 13, 14, 15, 16, 17, 18, 19, 20, 25, 30, 35, 40, 45, 50, or more features. Regardless of embodiment, these features can be determined through the use of any reproducible measurement technique or combination of measurement techniques. Such techniques include those that are well known in the art including any technique described herein or, for example, any technique disclosed in Section 5.4, *infra*. Typically, such techniques are used to measure feature values using a biological sample taken from a subject at a single point in time or multiple samples taken at multiple points in time. In one embodiment, an exemplary technique to obtain a biomarker profile from a sample taken from a subject is a cDNA microarray (see, e.g., Section 5.4.1.2 and Section 6, *infra*). In another embodiment, an exemplary technique to obtain a biomarker profile from a sample taken from a subject is a protein-based assay or other form of protein-based technique such as described in the BD Cytometric Bead Array (CBA) Human Inflammation Kit Instruction Manual (BD Biosciences) or the

bead assay described in U.S. Pat. No. 5,981,180, each of which is incorporated herein by reference in their entirety, and in particular for their teachings of various methods of assay protein concentrations in biological samples. In still another embodiment, the biomarker profile is mixed, meaning that it comprises some biomarkers that are nucleic acids, or indications thereof, and some biomarkers that are proteins, or indications thereof. In such embodiments, both protein based and nucleic acid based techniques are used to obtain a biomarker profile from one or more samples taken from a subject. In other words, the feature values for the features associated with the biomarkers in the biomarker profile that are nucleic acids are obtained by nucleic acid based measurement techniques (e.g., a nucleic acid microarray) and the feature values for the features associated with the biomarkers in the biomarker profile that are proteins are obtained by protein based measurement techniques. In some embodiments biomarker profiles can be obtained using a kit, such as a kit described in Section 5.3 below.

[0157] In specific embodiments, a subject is screened using the methods and compositions of the invention as frequently as necessary (e.g., during their stay in the ICU) to diagnose or predict sepsis or SIRS in a subject. In a preferred embodiment, the subject is screened soon after they arrive in the ICU. In some embodiments, the subject is screened daily after they arrive in the ICU. In some embodiments, the subject is screened every 1 to 4 hours, 1 to 8 hours, 8 to 12 hours, 12 to 16 hours, or 16 to 24 hours after they arrive in the ICU.

5.3 KITS

[0158] The invention also provides kits that are useful in diagnosing or predicting the development of sepsis or diagnosing SIRS in a subject. In some embodiments, the kits of the present invention comprise at least 2, 3, 4, 5, 6, 7, 8, 9, 10, 11, 12, 13, 14, 15, 16, 17, 18, 19, 20, 25, 30, 35, 40, 45, 50, 55, 60, 65, 70, 75, 80, 85, 90, 95, 96, 100, 105, 110, 115, 120, 125, 130, 135, 140, 145, 150, 155, 160, 165, 170, 175, 180, 185, 190, 195 or 200 or more biomarkers and/or reagents to detect the presence or abundance of such biomarkers. In other embodiments, the kits of the present invention comprise at least 2, but as many as several hundred or more biomarkers. In some embodiments, the kits of the present invention comprise at least 2, 3, 4, 5, 6, 7, 8, 9, 10, 11, 12, 13, 14, 15, 16, 17, 18, 19, 20, 25, 30, 35, 40, 45, 50 or more biomarkers selected from Table I of Section 5.11. In some embodiments, the kits of the present invention comprise at least 2, 3, 4, 5, 6, 7, 8, 9, 10, 11, 12, 13, 14, 15, 16, 17, 18, 19, 20, 25, 30, 35, 40 or more biomarkers selected from Table J of Section 5.11. In some embodiments, the kits of the present invention comprise at least 2, 3, 4, 5, 6, 7, 8, 9, or all 10 of the biomarkers in Table K of Section 5.11. In accordance with the definition of biomarkers given in Section 5.1, in some instances, a biomarker is in fact a discriminating molecule of, for example, a gene, mRNA, or protein rather than the gene, mRNA, or protein itself. Thus, a biomarker could be a molecule that indicates the presence or abundance of a particular gene or protein, or fragment thereof, identified in any one of Tables I, J, or K of Section 5.11 rather than the actual gene or protein itself. Such discriminating molecules are sometimes referred to in the art as "reagents." In some embodiments, the kits of the present invention comprise at least 2, but as many as several hundred or more biomarkers.

[0159] The biomarkers of the kits of the present invention can be used to generate biomarker profiles according to the

present invention. Examples of classes of compounds of the kit include, but are not limited to, proteins and fragments thereof, peptides, proteoglycans, glycoproteins, lipoproteins, carbohydrates, lipids, nucleic acids (e.g., DNA, such as cDNA or amplified DNA, or RNA, such as mRNA), organic or inorganic chemicals, natural or synthetic polymers, small molecules (e.g., metabolites), or discriminating molecules or discriminating fragments of any of the foregoing. In a specific embodiment, a biomarker is of a particular size, (e.g., at least 10, 15, 20, 25, 30, 35, 40, 45, 50, 55, 60, 65, 70, 75, 80, 85, 90, 95, 100, 105, 110, 115, 120, 125, 130, 135, 140, 145, 150, 155, 160, 165, 170, 175, 180, 185, 190, 195, 200, 1000, 2000, 3000, 5000, 10 k, 20 k, 100 k Daltons or greater). The biomarker(s) may be part of an array, or the biomarker(s) may be packaged separately and/or individually. The kit may also comprise at least one internal standard to be used in generating the biomarker profiles of the present invention. Likewise, the internal standard or standards can be any of the classes of compounds described above.

[0160] In one embodiment, the invention provides kits comprising probes and/or primers that may or may not be immobilized at an addressable position on a substrate, such as found, for example, in a microarray. In a particular embodiment, the invention provides such a microarray.

[0161] In a specific embodiment, the invention provides a kit for predicting the development of sepsis in a test subject that comprises a plurality of antibodies that specifically bind the protein-based biomarkers listed in any one of Tables 30, 31, 32, 33, 34, 36, I, J, or K. In such embodiments, the antibodies themselves are biomarkers within the scope of the present invention. In accordance with this embodiment, the kit may comprise a set of antibodies or functional fragments or derivatives thereof (e.g., Fab, F(ab)₂, Fv, or scFv fragments) that specifically bind at least 2, 3, 4, 5, 6, 7, 8, 9, 10, 11, 12, 13, 14, 15, 16, 17, 18, 19, 20, 25, 30, 35, 40, 45, 50, 55, 60, 65, 70, 75, 80, 85, 90, 95, 100, 105, 110, 115, 120, 125, 130, 135, 140, 145, 150, 155, 160, 165, 170, 175, 180, 185, 190, 195 or 200 or more of the protein-based biomarkers set forth in any one of Tables 30, 31, 32, 33, 34, 36, I, J, or K. In accordance with this embodiment, the kit may include antibodies, fragments or derivatives thereof (e.g., Fab, F(ab)₂, Fv, or scFv fragments) that are specific for the biomarkers of the present invention. In one embodiment, the antibodies may be detectably labeled.

[0162] In a specific embodiment, the invention provides a kit for predicting the development of sepsis in a test subject comprises a plurality of antibodies that specifically bind a plurality of the protein-based biomarkers listed in Table I of Section 5.11. In accordance with this embodiment, the kit may comprise a set of antibodies or functional fragments or derivatives thereof (e.g., Fab, F(ab)₂, Fv, or scFv fragments) that specifically bind at least 2, 3, 4, 5, 6, 7, 8, 9, 10, 11, 12, 13, 14, 15, 16, 17, 18, 19, 20, 25, 30, 35, 40, 45, 50 or more of the biomarkers set forth in Table I. In accordance with this embodiment, the kit may include antibodies, fragments or derivatives thereof (e.g., Fab, F(ab)₂, Fv, or scFv fragments) that are specific for the biomarkers of the present invention. In one embodiment, the antibodies may be detectably labeled.

[0163] In other embodiments of the invention, a kit may comprise a specific biomarker binding component, such as an aptamer. If the biomarkers comprise a nucleic acid, the kit may provide an oligonucleotide probe that is capable of forming a duplex with the biomarker or with a complementary strand of a biomarker. The oligonucleotide probe may be

detectably labeled. In such embodiments, the probes are themselves biomarkers that fall within the scope of the present invention.

[0164] The kits of the present invention may also include additional compositions, such as buffers, that can be used in constructing the biomarker profile. Prevention of the action of microorganisms can be ensured by the inclusion of various antibacterial and antifungal agents, for example, paraben, chlorobutanol, phenol sorbic acid, and the like. It may also be desirable to include isotonic agents such as sugars, sodium chloride, and the like.

[0165] Some kits of the present invention comprise a microarray. In one embodiment this microarray comprises a plurality of probe spots, wherein at least twenty percent of the probe spots in the plurality of probe spots correspond to biomarkers in any one of Tables 30, 31, 32, 33, 34, 36, I, J, or K. In some embodiments, at least twenty-five percent, at least thirty percent, at least thirty-five percent, at least forty percent, or at least sixty percent, or at least eighty percent of the probe spots in the plurality of probe spots correspond to biomarkers in any one of Tables 30, 31, 32, 33, 34, 36, I, J, or K. Such probe spots are biomarkers within the scope of the present invention. In some embodiments, the microarray consists of between about three and about one hundred probe spots on a substrate. In some embodiments, the microarray consists of between about three and about one hundred probe spots on a substrate. As used in this context, the term "about" means within five percent of the stated value, within ten percent of the stated value, or within twenty-five percent of the stated value. In some embodiments, such microarrays contain one or more probe spots for inter-microarray calibration or for calibration with other microarrays such as reference microarrays using techniques that are known to those of skill in the art. In some embodiments such microarrays are nucleic acid microarrays. In some embodiments, such microarrays are protein microarrays.

[0166] Some kits of the invention may further comprise a computer program product for use in conjunction with a computer system, wherein the computer program product comprises a computer readable storage medium and a computer program mechanism embedded therein. In such kits, the computer program mechanism comprises instructions for evaluating whether a plurality of features in a biomarker profile of a test subject at risk for developing sepsis satisfies a first value set. Satisfying the first value set predicts that the test subject is likely to develop sepsis. In one embodiment, the plurality of features corresponds to biomarkers listed in any one of Tables 30, 31, 32, 33, 34, 36, I, J, or K. In some kits, the computer program product further comprises instructions for evaluating whether the plurality of features in the biomarker profile of the test subject satisfies a second value set. Satisfying the second value set predicts that the test subject is not likely to develop sepsis.

[0167] Some kits of the present invention comprise a computer having a central processing unit and a memory coupled to the central processing unit. The memory stores instructions for evaluating whether a plurality of features in a biomarker profile of a test subject at risk for developing sepsis satisfies a first value set. Satisfying the first value set predicts that the test subject is likely to develop sepsis. In one embodiment, the plurality of features corresponds to biomarkers listed in any one of Tables 30, 31, 32, 33, 34, 36, I, J, or K.

[0168] FIG. 35 details an exemplary system that supports the functionality described above. The system is preferably a computer system 10 having:

[0169] a central processing unit 22;

[0170] a main non-volatile storage unit 14, for example, a hard disk drive, for storing software and data, the storage unit 14 controlled by storage controller 12;

[0171] a system memory 36, preferably high speed random-access memory (RAM), for storing system control programs, data, and application programs, comprising programs and data loaded from non-volatile storage unit 14; system memory 36 may also include read-only memory (ROM);

[0172] a user interface 32, comprising one or more input devices (e.g., keyboard 28) and a display 26 or other output device;

[0173] a network interface card 20 for connecting to any wired or wireless communication network 34 (e.g., a wide area network such as the Internet);

[0174] an internal bus 30 for interconnecting the aforementioned elements of the system; and

[0175] a power source 24 to power the aforementioned elements.

[0176] Operation of computer 10 is controlled primarily by operating system 40, which is executed by central processing unit 22. Operating system 40 can be stored in system memory 36. In addition to operating system 40, in a typical implementation, system memory 36 includes:

[0177] file system 42 for controlling access to the various files and data structures used by the present invention;

[0178] a training data set 44 for use in construction one or more decision rules in accordance with the present invention;

[0179] a data analysis algorithm module 54 for processing training data and constructing decision rules;

[0180] one or more decision rules 56;

[0181] a biomarker profile evaluation module 60 for determining whether a plurality of features in a biomarker profile of a test subject satisfies a first value set or a second value set;

[0182] a test subject biomarker profile 62 comprising biomarkers 64 and, for each such biomarkers, features 66; and

[0183] a database 68 of select biomarkers of the present invention (e.g., Table 30 and/or Table I and/or Table J and/or Table K, and/or Table L and/or Table M and/or Table N and/or Table O etc.) and/or one or features for each of these select biomarkers.

[0184] Training data set 46 comprises data for a plurality of subjects 46. For each subject 46 there is a subject identifier 48 and a plurality of biomarkers 50. For each biomarker 50, there is at least one feature 52. Although not shown in FIG. 35, for each feature 52, there is a feature value. For each decision rule 56 constructed using data analysis algorithms, there is at least one decision rule value set 58.

[0185] As illustrated in FIG. 35, computer 10 comprises software program modules and data structures. The data structures stored in computer 10 include training data set 44, decision rules 56, test subject biomarker profile 62, and biomarker database 68. Each of these data structures can comprise any form of data storage system including, but not limited to, a flat ASCII or binary file, an Excel spreadsheet, a relational database (SQL), or an on-line analytical processing (OLAP) database (MDX and/or variants thereof). In some specific

embodiments, such data structures are each in the form of one or more databases that include hierarchical structure (e.g., a star schema). In some embodiments, such data structures are each in the form of databases that do not have explicit hierarchy (e.g., dimension tables that are not hierarchically arranged).

[0186] In some embodiments, each of the data structures stored or accessible to system 10 are single data structures. In other embodiments, such data structures in fact comprise a plurality of data structures (e.g., databases, files, archives) that may or may not all be hosted by the same computer 10. For example, in some embodiments, training data set 44 comprises a plurality of Excel spreadsheets that are stored either on computer 10 and/or on computers that are addressable by computer 10 across wide area network 34. In another example, training data set 44 comprises a database that is either stored on computer 10 or is distributed across one or more computers that are addressable by computer 10 across wide area network 34.

[0187] It will be appreciated that many of the modules and data structures illustrated in FIG. 35 can be located on one or more remote computers. For example, some embodiments of the present application are web service-type implementations. In such embodiments, biomarker profile evaluation module 60 and/or other modules can reside on a client computer that is in communication with computer 10 via network 34. In some embodiments, for example, biomarker profile evaluation module 60 can be an interactive web page.

[0188] In some embodiments, training data set 44, decision rules 56, and/or biomarker database 68 illustrated in FIG. 35 are on a single computer (computer 10) and in other embodiments one or more of such data structures and modules are hosted by one or more remote computers (not shown). Any arrangement of the data structures and software modules illustrated in FIG. 35 on one or more computers is within the scope of the present invention so long as these data structures and software modules are addressable with respect to each other across network 34 or by other electronic means. Thus, the present invention fully encompasses a broad array of computer systems.

[0189] Still another kit of the present invention comprises computers and computer readable media for evaluating whether a test subject is likely to develop sepsis or SIRS. For instance, one embodiment of the present invention provides a computer program product for use in conjunction with a computer system. The computer program product comprises a computer readable storage medium and a computer program mechanism embedded therein. The computer program mechanism comprises instructions for evaluating whether a plurality of features in a biomarker profile of a test subject at risk for developing sepsis satisfies a first value set. Satisfaction of the first value set predicts that the test subject is likely to develop sepsis. The plurality of features are measurable aspects of a plurality of biomarkers, the plurality of biomarkers comprising at least three biomarkers listed in Table I. In certain embodiments, the plurality of biomarkers comprises at least six biomarkers listed in Table I, wherein the plurality of biomarkers comprises both IL-6 and IL-8. In some embodiments, the computer program product further comprises instructions for evaluating whether the plurality of features in the biomarker profile of the test subject satisfies a second value set. Satisfaction of the second value set predicts that the test subject is not likely to develop sepsis. In some embodiments, the biomarker profile has between 3 and 50

biomarkers listed in Table I, between 3 and 40 biomarkers listed in Table I, at least four biomarkers listed in Table I, or at least eight biomarkers listed in Table I.

[0190] Another kit of the present invention comprises a central processing unit and a memory coupled to the central processing unit. The memory stores instructions for evaluating whether a plurality of features in a biomarker profile of a test subject at risk for developing sepsis satisfies a first value set. Satisfaction of the first value set predicts that the test subject is likely to develop sepsis. The plurality of features are measurable aspects of a plurality of biomarkers. This plurality of biomarkers comprises at least three biomarkers from Table I. In some embodiments, the plurality of biomarkers comprises at least six biomarkers listed in Table I when the plurality of biomarkers comprises both IL-6 and IL-8. In some embodiments, the memory further stores instructions for evaluating whether the plurality of features in the biomarker profile of the test subject satisfies a second value set, wherein satisfying the second value set predicts that the test subject is not likely to develop sepsis. In some embodiments, the biomarker profile consists of between 3 and 50 biomarkers listed in Table I, between 3 and 40 biomarkers listed in Table I, at least four biomarkers listed in Table I, or at least eight biomarkers listed in Table I.

[0191] Another kit in accordance with the present invention comprises a computer system for determining whether a subject is likely to develop sepsis. The computer system comprises a central processing unit and a memory, coupled to the central processing unit. The memory stores instructions for obtaining a biomarker profile of a test subject. The biomarker profile comprises a plurality of features. Each feature in the plurality of features is a measurable aspect of a corresponding biomarker in a plurality of biomarkers. The plurality of biomarkers comprises at least three biomarkers listed in Table I. The memory further comprises instructions for transmitting the biomarker profile to a remote computer. The remote computer includes instructions for evaluating whether the plurality of features in the biomarker profile of the test subject satisfies a first value set. Satisfaction of the first value set predicts that the test subject is likely to develop sepsis. The memory further comprises instructions for receiving a determination, from the remote computer, as to whether the plurality of features in the biomarker profile of the test subject satisfies the first value set. The memory also comprises instructions for reporting whether the plurality of features in the biomarker profile of the test subject satisfies the first value set. In some embodiments, the plurality of biomarkers comprises at least six biomarkers listed in Table I when the plurality of biomarkers comprises both IL-6 and IL-8. In some embodiments, the remote computer further comprises instructions for evaluating whether the plurality of features in the biomarker profile of the test subject satisfies a second value set. Satisfaction of the second value set predicts that the test subject is not likely to develop sepsis. In such embodiments, the memory further comprises instructions for receiving a determination, from the remote computer, as to whether the plurality of features in the biomarker profile of the test subject satisfies the second set as well as instructions for reporting whether the plurality of features in the biomarker profile of the test subject satisfies the second value set. In some embodiments, the plurality of biomarkers comprises at least four biomarkers listed in Table I. In some embodiments, the plurality of biomarkers comprises at least six biomarkers listed in Table I.

[0192] Still another aspect of the present invention comprises a digital signal embodied on a carrier wave comprising a respective value for each of a plurality of features in a biomarker profile. The plurality of features are measurable aspects of a plurality of biomarkers. The plurality of biomarkers comprises at least three biomarkers listed in Table I. In some embodiments, the plurality of biomarkers comprises at least six biomarkers listed in Table I when the plurality of biomarkers comprises both IL-6 and IL-8. In some embodiments, the plurality of biomarkers comprises at least four biomarkers listed in Table I. In some embodiments, the plurality of biomarkers comprises at least eight biomarkers listed in Table I.

[0193] Still another aspect of the present invention provides a digital signal embodied on a carrier wave comprising a determination as to whether a plurality of features in a biomarker profile of a test subject satisfies a value set. The plurality of features are measurable aspects of a plurality of biomarkers. This plurality of biomarkers comprises at least three biomarkers listed in Table I. Satisfying the value set predicts that the test subject is likely to develop sepsis. In some embodiments, the plurality of biomarkers comprises at least six biomarkers listed in Table I when the plurality of biomarkers comprises both IL-6 and IL-8. In some embodiments, the plurality of biomarkers comprises at least four biomarkers listed in Table I. In some embodiments, the plurality of biomarkers comprises at least eight biomarkers listed in Table I.

[0194] Still another embodiment provides a digital signal embodied on a carrier wave comprising a determination as to whether a plurality of features in a biomarker profile of a test subject satisfies a value set. The plurality of features are measurable aspects of a plurality of biomarkers. The plurality of biomarkers comprise at least three biomarkers listed in Table I. Satisfaction of the value set predicts that the test subject is not likely to develop sepsis. In some embodiments, the plurality of biomarkers comprises at least six biomarkers listed in Table I when the plurality of biomarkers comprises both IL-6 and IL-8. In some embodiments, the plurality of biomarkers comprises at least four biomarkers listed in Table I. In some embodiments, the plurality of biomarkers comprises at least eight biomarkers listed in Table I.

[0195] Still another embodiment of the present invention provides a graphical user interface for determining whether a subject is likely to develop sepsis. The graphical user interface comprises a display field for a displaying a result encoded in a digital signal embodied on a carrier wave received from a remote computer. The plurality of features are measurable aspects of a plurality of biomarkers. The plurality of biomarkers comprise at least three biomarkers listed in Table I. The result has a first value when a plurality of features in a biomarker profile of a test subject satisfies a first value set. The result has a second value when a plurality of features in a biomarker profile of a test subject satisfies a second value set. In some embodiments, the plurality of biomarkers comprises at least six biomarkers listed in Table I when the plurality of biomarkers comprises IL-6 and IL-8. In some embodiments, the plurality of biomarkers comprises at least four biomarkers listed in Table I. In some embodiments, the plurality of biomarkers comprises at least eight biomarkers listed in Table I.

[0196] Yet another kit of the present invention provides a computer system for determining whether a subject is likely to develop sepsis. The computer system comprises a central processing unit and a memory, coupled to the central processing unit. The memory stores instructions for obtaining a

biomarker profile of a test subject. The biomarker profile comprises a plurality of features. The plurality of features are measurable aspects of a plurality of biomarkers. The plurality of biomarkers comprise at least three biomarkers listed in Table I. The memory further stores instructions for evaluating whether the plurality of features in the biomarker profile of the test subject satisfies a first value set. Satisfying the first value set predicts that the test subject is likely to develop sepsis. The memory also stores instructions for reporting whether the plurality of features in the biomarker profile of the test subject satisfies the first value set. In some embodiments, the plurality of biomarkers comprises at least six biomarkers listed in Table I when the plurality of biomarkers comprises both IL-6 and IL-8. In some embodiments, the plurality of biomarkers comprises at least four biomarkers listed in Table I. In some embodiments, the plurality of biomarkers comprises at least eight biomarkers listed in Table I.

5.4 GENERATION OF BIOMARKER PROFILES

[0197] According to one embodiment, the methods of the present invention comprise generating a biomarker profile from a biological sample taken from a subject. The biological sample may be, for example, whole blood, plasma, serum, red blood cells, platelets, neutrophils, eosinophils, basophils, lymphocytes, monocytes, saliva, sputum, urine, cerebral spinal fluid, cells, a cellular extract, a tissue sample, a tissue biopsy, a stool sample or any sample that may be obtained from a subject using techniques well known to those of skill in the art. In a specific embodiment, a biomarker profile is determined using samples collected from a subject at one or more separate time points. In another specific embodiment, a biomarker profile is generated using samples obtained from a subject at separate time points. In one example, these samples are obtained from the subject either once or, alternatively, on a daily basis, or more frequently, e.g., every 4, 6, 8 or 12 hours. In a specific embodiment, a biomarker profile is determined using samples collected from a single tissue type. In another specific embodiment, a biomarker profile is determined using samples collected from at least two different tissue types.

5.4.1 Methods of Detecting Nucleic Acid Biomarkers

[0198] In specific embodiments of the invention, biomarkers in a biomarker profile are nucleic acids. Such biomarkers and corresponding features of the biomarker profile may be generated, for example, by detecting the expression product (e.g., a polynucleotide or polypeptide) of one or more genes described herein (e.g., a gene listed in Table 30, Table I, Table J, or Table K.). In a specific embodiment, the biomarkers and corresponding features in a biomarker profile are obtained by detecting and/or analyzing one or more nucleic acids expressed from a gene disclosed herein (e.g., a gene listed in Table 30, Table I, Table J, or Table K) using any method well known to those skilled in the art including, but by no means limited to, hybridization, microarray analysis, RT-PCR, nuclease protection assays and Northern blot analysis.

[0199] In certain embodiments, nucleic acids detected and/or analyzed by the methods and compositions of the invention include RNA molecules such as, for example, expressed RNA molecules which include messenger RNA (mRNA) molecules, mRNA spliced variants as well as regulatory RNA, cRNA molecules (e.g., RNA molecules prepared from cDNA

molecules that are transcribed in vitro) and discriminating fragments thereof. Nucleic acids detected and/or analyzed by the methods and compositions of the present invention can also include, for example, DNA molecules such as genomic DNA molecules, cDNA molecules, and discriminating fragments thereof (e.g., oligonucleotides, ESTs, STSs, etc.).

[0200] The nucleic acid molecules detected and/or analyzed by the methods and compositions of the invention may be naturally occurring nucleic acid molecules such as genomic or extragenomic DNA molecules isolated from a sample, or RNA molecules, such as mRNA molecules, present in, isolated from or derived from a biological sample. The sample of nucleic acids detected and/or analyzed by the methods and compositions of the invention comprise, e.g., molecules of DNA, RNA, or copolymers of DNA and RNA. Generally, these nucleic acids correspond to particular genes or alleles of genes, or to particular gene transcripts (e.g., to particular mRNA sequences expressed in specific cell types or to particular cDNA sequences derived from such mRNA sequences). The nucleic acids detected and/or analyzed by the methods and compositions of the invention may correspond to different exons of the same gene, e.g., so that different splice variants of that gene may be detected and/or analyzed.

[0201] In specific embodiments, the nucleic acids are prepared in vitro from nucleic acids present in, or isolated or partially isolated from biological a sample. For example, in one embodiment, RNA is extracted from a sample (e.g., total cellular RNA, poly(A)⁺messenger RNA, fraction thereof) and messenger RNA is purified from the total extracted RNA. Methods for preparing total and poly(A)⁺ RNA are well known in the art, and are described generally, e.g., in Sambrook et al., 2001, *Molecular Cloning: A Laboratory Manual*, 3rd ed. Cold Spring Harbor Laboratory Press (Cold Spring Harbor, N.Y.), which is incorporated by reference herein in its entirety. In one embodiment, RNA is extracted from a sample using guanidinium thiocyanate lysis followed by CsCl centrifugation and an oligo dT purification (Chirgwin et al., 1979, *Biochemistry* 18:5294-5299). In another embodiment, RNA is extracted from a sample using guanidinium thiocyanate lysis followed by purification on RNeasy columns (Qiagen, Valencia, Calif.). cDNA is then synthesized from the purified mRNA using, e.g., oligo-dT or random primers. In specific embodiments, the target nucleic acids are cRNA prepared from purified messenger RNA extracted from a sample. As used herein, cRNA is defined here as RNA complementary to the source RNA. The extracted RNAs are amplified using a process in which doubled-stranded cDNAs are synthesized from the RNAs using a primer linked to an RNA polymerase promoter in a direction capable of directing transcription of anti-sense RNA. Anti-sense RNAs or cRNAs are then transcribed from the second strand of the double-stranded cDNAs using an RNA polymerase (see, e.g., U.S. Pat. Nos. 5,891,636, 5,716,785; 5,545,522 and 6,132,997, which are hereby incorporated by reference). Both oligo-dT primers (U.S. Pat. Nos. 5,545,522 and 6,132,997, hereby incorporated by reference herein) or random primers that contain an RNA polymerase promoter or complement thereof can be used. In some embodiments the target nucleic acids are short and/or fragmented nucleic acid molecules which are representative of the original nucleic acid population of the sample.

[0202] In one embodiment, nucleic acids of the invention can be detectably labeled. For example, cDNA can be labeled directly, e.g., with nucleotide analogs, or indirectly, e.g., by

making a second, labeled cDNA strand using the first strand as a template. Alternatively, the double-stranded cDNA can be transcribed into cRNA and labeled.

[0203] In some embodiments the detectable label is a fluorescent label, e.g., by incorporation of nucleotide analogs. Other labels suitable for use in the present invention include, but are not limited to, biotin, imminobiotin, antigens, cofactors, dinitrophenol, lipoic acid, olefinic compounds, detectable polypeptides, electron rich molecules, enzymes capable of generating a detectable signal by action upon a substrate, and radioactive isotopes. Suitable radioactive isotopes include ³²P, ³⁵S, ¹⁴C, ¹⁵N and ¹²⁵I. Fluorescent molecules suitable for the present invention include, but are not limited to, fluorescein and its derivatives, rhodamine and its derivatives, Texas red, 5' carboxy-fluorescein ("FMA"), 6-carboxy-4',5'-dichloro-2',7'-dimethoxyfluorescein, succinimidyl ester ("JOE"), 6-carboxytetramethylrhodamine ("TAMRA"), 6Ncarboxy-X-rhodamine ("ROX"), HEX, TET, IRD40, and IRD41. Fluorescent molecules that are suitable for the invention further include, but are not limited to: cyanine dyes, including by not limited to Cy3, Cy3.5 and Cy5; BODIPY dyes including but not limited to BODIPY-FL, BODIPY-TR, BODIPY-TMR, BODIPY-630/650, BODIPY-650/670; and ALEXA dyes, including but not limited to ALEXA-488, ALEXA-532, ALEXA-546, ALEXA-568, and ALEXA-594; as well as other fluorescent dyes which will be known to those who are skilled in the art. Electron-rich indicator molecules suitable for the present invention include, but are not limited to, ferritin, hemocyanin, and colloidal gold. Alternatively, in some embodiments the target nucleic acids may be labeled by specifically complexing a first group to the nucleic acid. A second group, covalently linked to an indicator molecules and which has an affinity for the first group, can be used to indirectly detect the target nucleic acid. In such an embodiment, compounds suitable for use as a first group include, but are not limited to, biotin and iminobiotin. Compounds suitable for use as a second group include, but are not limited to, avidin and streptavidin.

5.4.1.1 Nucleic Acid Arrays

[0204] In certain embodiments of the invention, nucleic acid arrays are employed to generate features of biomarkers in a biomarker profile by detecting the expression of any one or more of the genes described herein (e.g., a gene listed in Table 30, Table I, Table J or Table K). In one embodiment of the invention, a microarray, such as a cDNA microarray, is used to determine feature values of biomarkers in a biomarker profile. The diagnostic use of cDNA arrays is well known in the art. (See, e.g., Zou et al., 2002, *Oncogene* 21:4855-4862; as well as Draghici, 2003, *Data Analysis Tools for DNA Microarrays*, Chapman & Hall/CRC, each of which is hereby incorporated by reference herein in its entirety). Exemplary methods for cDNA microarray analysis are described below, and in the examples in Section 6, infra.

[0205] In certain embodiments, the feature values for biomarkers in a biomarker profile are obtained by hybridizing to the array detectably labeled nucleic acids representing or corresponding to the nucleic acid sequences in mRNA transcripts present in a biological sample (e.g., fluorescently labeled cDNA synthesized from the sample) to a microarray comprising one or more probe spots.

[0206] Nucleic acid arrays, for example, microarrays, can be made in a number of ways, of which several are described herein below. Preferably, the arrays are reproducible, allow-

ing multiple copies of a given array to be produced and results from said microarrays compared with each other. Preferably, the arrays are made from materials that are stable under binding (e.g., nucleic acid hybridization) conditions. Those skilled in the art will know of suitable supports, substrates or carriers for hybridizing test probes to probe spots on an array, or will be able to ascertain the same by use of routine experimentation.

[0207] Arrays, for example, microarrays, used can include one or more test probes. In some embodiments each such test probe comprises a nucleic acid sequence that is complementary to a subsequence of RNA or DNA to be detected. Each probe typically has a different nucleic acid sequence, and the position of each probe on the solid surface of the array is usually known or can be determined. Arrays useful in accordance with the invention can include, for example, oligo-nucleotide microarrays, cDNA based arrays, SNP arrays, spliced variant arrays and any other array able to provide a qualitative, quantitative or semi-quantitative measurement of expression of a gene described herein (e.g., a gene listed in Table 30, Table I, Table J or Table K). Some types of microarrays are addressable arrays. More specifically, some microarrays are positionally addressable arrays. In some embodiments, each probe of the array is located at a known, predetermined position on the solid support so that the identity (e.g., the sequence) of each probe can be determined from its position on the array (e.g., on the support or surface). In some embodiments, the arrays are ordered arrays. Microarrays are generally described in Draghici, 2003, *Data Analysis Tools for DNA Microarrays*, Chapman & Hall/CRC, which is hereby incorporated herein by reference in its entirety.

[0208] In some embodiments of the present invention, an expressed transcript (e.g., a transcript of a gene described herein) is represented in the nucleic acid arrays. In such embodiments, a set of binding sites can include probes with different nucleic acids that are complementary to different sequence segments of the expressed transcript. Exemplary nucleic acids that fall within this class can be of length of 15 to 200 bases, 20 to 100 bases, 25 to 50 bases, 40 to 60 bases or some other range of bases. Each probe sequence can also comprise one or more linker sequences in addition to the sequence that is complementary to its target sequence. As used herein, a linker sequence is a sequence between the sequence that is complementary to its target sequence and the surface of support. For example, the nucleic acid arrays of the invention can comprise one probe specific to each target gene or exon. However, if desired, the nucleic acid arrays can contain at least 2, 5, 10, 100, or 1000 or more probes specific to some expressed transcript (e.g., a transcript of a gene described herein, e.g., in Table 30, Table I, Table J, or Table K). For example, the array may contain probes tiled across the sequence of the longest mRNA isoform of a gene.

[0209] It will be appreciated that when cDNA complementary to the RNA of a cell, for example, a cell in a biological sample, is made and hybridized to a microarray under suitable hybridization conditions, the level of hybridization to the site in the array corresponding to a gene described herein (e.g., a gene listed in Table 30, Table I, Table J, or Table K) will reflect the prevalence in the cell of mRNA or mRNAs transcribed from that gene. Alternatively, in instances where multiple isoforms or alternate splice variants produced by particular genes are to be distinguished, detectably labeled (e.g., with a fluorophore) cDNA complementary to the total cellular mRNA can be hybridized to a microarray, and the site on the

array corresponding to an exon of the gene that is not transcribed or is removed during RNA splicing in the cell will have little or no signal (e.g., fluorescent signal), and a site corresponding to an exon of a gene for which the encoded mRNA expressing the exon is prevalent will have a relatively strong signal. The relative abundance of different mRNAs produced from the same gene by alternative splicing is then determined by the signal strength pattern across the whole set of exons monitored for the gene.

[0210] In one embodiment, hybridization levels at different hybridization times are measured separately on different, identical microarrays. For each such measurement, at hybridization time when hybridization level is measured, the microarray is washed briefly, preferably in room temperature in an aqueous solution of high to moderate salt concentration (e.g., 0.5 to 3 M salt concentration) under conditions which retain all bound or hybridized nucleic acids while removing all unbound nucleic acids. The detectable label on the remaining, hybridized nucleic acid molecules on each probe is then measured by a method which is appropriate to the particular labeling method used. The resulting hybridization levels are then combined to form a hybridization curve. In another embodiment, hybridization levels are measured in real time using a single microarray. In this embodiment, the microarray is allowed to hybridize to the sample without interruption and the microarray is interrogated at each hybridization time in a non-invasive manner. In still another embodiment, one can use one array, hybridize for a short time, wash and measure the hybridization level, put back to the same sample, hybridize for another period of time, wash and measure again to get the hybridization time curve.

[0211] In some embodiments, nucleic acid hybridization and wash conditions are chosen so that the nucleic acid biomarkers to be analyzed specifically bind or specifically hybridize to the complementary nucleic acid sequences of the array, typically to a specific array site, where its complementary DNA is located.

[0212] Arrays containing double-stranded probe DNA situated thereon can be subjected to denaturing conditions to render the DNA single-stranded prior to contacting with the target nucleic acid molecules. Arrays containing single-stranded probe DNA (e.g., synthetic oligodeoxyribonucleic acids) may need to be denatured prior to contacting with the target nucleic acid molecules, e.g., to remove hairpins or dimers which form due to self complementary sequences.

[0213] Optimal hybridization conditions will depend on the length (e.g., oligomer versus polynucleotide greater than 200 bases) and type (e.g., RNA, or DNA) of probe and target nucleic acids. General parameters for specific (i.e., stringent) hybridization conditions for nucleic acids are described in Sambrook et al., (supra), and in Ausubel et al., 1988, *Current Protocols in Molecular Biology*, Greene Publishing and Wiley-Interscience, New York. When the cDNA microarrays of Shena et al. are used, typical hybridization conditions are hybridization in 5×SSC plus 0.2% SDS at 65° C. for four hours, followed by washes at 25° C. in low stringency wash buffer (1×SSC plus 0.2% SDS), followed by 10 minutes at 25° C. in higher stringency wash buffer (0.1×SSC plus 0.2% SDS) (Shena et al., 1996, *Proc. Natl. Acad. Sci. U.S.A.* 93: 10614). Useful hybridization conditions are also provided in, e.g., Tijssen, 1993, *Hybridization With Nucleic Acid Probes*, Elsevier Science Publishers B.V.; Kricka, 1992, *Nonisotopic DNA Probe Techniques*, Academic Press, San Diego, Calif.; and Zou et al., 2002, *Oncogene* 21:4855-4862; and Draghici,

Data Analysis Tools for DNA Microanalysis, 2003, CRC Press LLC, Boca Raton, Fla., pp. 342-343, which are hereby incorporated by reference herein in their entirety.

[0214] In a specific embodiment, a microarray can be used to sort out RT-PCR products that have been generated by the methods described, for example, below in Section 5.4.1.2.

5.4.1.2 RT-PCR

[0215] In certain embodiments, to determine the feature values of biomarkers in a biomarker profile of the invention, the level of expression of one or more of the genes described herein (e.g., a gene listed in Table 30, Table I, Table J, or Table K) is measured by amplifying RNA from a sample using reverse transcription (RT) in combination with the polymerase chain reaction (PCR). In accordance with this embodiment, the reverse transcription may be quantitative or semi-quantitative. The RT-PCR methods taught herein may be used in conjunction with the microarray methods described above, for example, in Section 5.4.1.1. For example, a bulk PCR reaction may be performed, the PCR products may be resolved and used as probe spots on a microarray. See also Section 6.10, *infra*.

[0216] Total RNA, or mRNA from a sample is used as a template and a primer specific to the transcribed portion of the gene(s) is used to initiate reverse transcription. Methods of reverse transcribing RNA into cDNA are well known and described in Sambrook et al., 2001, *supra*. Primer design can be accomplished based on known nucleotide sequences that have been published or available from any publicly available sequence database such as GenBank. For example, primers may be designed for any of the genes described herein (see, e.g., in Table 30, Table I, Table J, or Table K). Further, primer design may be accomplished by utilizing commercially available software (e.g., Primer Designer 1.0, Scientific Software etc.). The product of the reverse transcription is subsequently used as a template for PCR.

[0217] PCR provides a method for rapidly amplifying a particular nucleic acid sequence by using multiple cycles of DNA replication catalyzed by a thermostable, DNA-dependent DNA polymerase to amplify the target sequence of interest. PCR requires the presence of a nucleic acid to be amplified, two single-stranded oligonucleotide primers flanking the sequence to be amplified, a DNA polymerase, deoxyribonucleoside triphosphates, a buffer and salts. The method of PCR is well known in the art. PCR, is performed, for example, as described in Mullis and Faloona, 1987, *Methods Enzymol.* 155:335, which is hereby incorporated herein by reference in its entirety.

[0218] PCR can be performed using template DNA or cDNA (at least 1 fg; more usefully, 1-1000 ng) and at least 25 pmol of oligonucleotide primers. A typical reaction mixture includes: 2 μ l of DNA, 25 pmol of oligonucleotide primer, 2.5 μ l of 10 M PCR buffer 1 (Perkin-Elmer, Foster City, Calif.), 0.4 μ l of 1.25 M dNTP, 0.15 μ l (or 2.5 units) of Taq DNA polymerase (Perkin Elmer, Foster City, Calif.) and deionized water to a total volume of 25 μ l. Mineral oil is overlaid and the PCR is performed using a programmable thermal cycler.

[0219] The length and temperature of each step of a PCR cycle, as well as the number of cycles, are adjusted according to the stringency requirements in effect. Annealing temperature and timing are determined both by the efficiency with which a primer is expected to anneal to a template and the degree of mismatch that is to be tolerated. The ability to optimize the stringency of primer annealing conditions is

well within the knowledge of one of moderate skill in the art. An annealing temperature of between 30° C. and 72° C. is used. Initial denaturation of the template molecules normally occurs at between 92° C. and 99° C. for 4 minutes, followed by 20-40 cycles consisting of denaturation (94-99° C. for 15 seconds to 1 minute), annealing (temperature determined as discussed above; 1-2 minutes), and extension (72° C. for 1 minute). The final extension step is generally carried out for 4 minutes at 72° C., and may be followed by an indefinite (0-24 hour) step at 4° C.

[0220] Quantitative RT-PCR ("QRT-PCR"), which is quantitative in nature, can also be performed to provide a quantitative measure of gene expression levels. In QRT-PCR reverse transcription and PCR can be performed in two steps, or reverse transcription combined with PCR can be performed concurrently. One of these techniques, for which there are commercially available kits such as Taqman (Perkin Elmer, Foster City, Calif.) or as provided by Applied Biosystems (Foster City, Calif.) is performed with a transcript-specific antisense probe. This probe is specific for the PCR product (e.g. a nucleic acid fragment derived from a gene) and is prepared with a quencher and fluorescent reporter probe complexed to the 5' end of the oligonucleotide. Different fluorescent markers are attached to different reporters, allowing for measurement of two products in one reaction. When Taq DNA polymerase is activated, it cleaves off the fluorescent reporters of the probe bound to the template by virtue of its 5'-to-3' exonuclease activity. In the absence of the quenchers, the reporters now fluoresce. The color change in the reporters is proportional to the amount of each specific product and is measured by a fluorometer; therefore, the amount of each color is measured and the PCR product is quantified. The PCR reactions are performed in 96-well plates so that samples derived from many individuals are processed and measured simultaneously. The Taqman system, has the additional advantage of not requiring gel electrophoresis and allows for quantification when used with a standard curve.

[0221] A second technique useful for detecting PCR products quantitatively is to use an intercalating dye such as the commercially available QuantiTect SYBR Green PCR (Qiagen, Valencia Calif.). RT-PCR is performed using SYBR green as a fluorescent label which is incorporated into the PCR product during the PCR stage and produces a fluorescence proportional to the amount of PCR product.

[0222] Both Taqman and QuantiTect SYBR systems can be used subsequent to reverse transcription of RNA. Reverse transcription can either be performed in the same reaction mixture as the PCR step (one-step protocol) or reverse transcription can be performed first prior to amplification utilizing PCR (two-step protocol).

[0223] Additionally, other systems to quantitatively measure mRNA expression products are known including Molecular Beacons® which uses a probe having a fluorescent molecule and a quencher molecule, the probe capable of forming a hairpin structure such that when in the hairpin form, the fluorescence molecule is quenched, and when hybridized the fluorescence increases giving a quantitative measurement of gene expression.

[0224] Additional techniques to quantitatively measure RNA expression include, but are not limited to, polymerase chain reaction, ligase chain reaction, Qbeta replicase (see, e.g., International Application No. PCT/US87/00880, which is hereby incorporated by reference), isothermal amplification method (see, e.g., Walker et al., 1992, *PNAS* 89:382-396,

which is hereby incorporated herein by reference), strand displacement amplification (SDA), repair chain reaction, Asymmetric Quantitative PCR (see, e.g., U.S. Publication No. US 2003/30134307A1, herein incorporated by reference) and the multiplex microsphere bead assay described in Fujita et al., 2004, *Journal of Biotechnology* 108:193-205, herein incorporated by reference.

[0225] The level of expression of one or more of the genes described herein (e.g., the genes listed in Table 30, Table I, Table J, or Table K) can, for example, be measured by amplifying RNA from a sample using amplification (NASBA). See, e.g., Kwok et al., 1989, *PNAS USA* 86:1173; International Publication No. WO 88/10315; and U.S. Pat. No. 6,329,179, each of which is hereby incorporated by reference. In NASBA, the nucleic acids may be prepared for amplification using conventional methods, e.g., phenol/chloroform extraction, heat denaturation, treatment with lysis buffer and minispin columns for isolation of DNA and RNA or guanidinium chloride extraction of RNA. These amplification techniques involve annealing a primer that has target specific sequences. Following polymerization, DNA/RNA hybrids are digested with RNase H while double stranded DNA molecules are heat denatured again. In either case the single stranded DNA is made fully double stranded by addition of second target specific primer, followed by polymerization. The double-stranded DNA molecules are then multiply transcribed by a polymerase such as T7 or SP6. In an isothermal cyclic reaction, the RNA's are reverse transcribed into double stranded DNA, and transcribed once with a polymerase such as T7 or SP6. The resulting products, whether truncated or complete, indicate target specific sequences.

[0226] Several techniques may be used to separate amplification products. For example, amplification products may be separated by agarose, agarose-acrylamide or polyacrylamide gel electrophoresis using conventional methods. See Sambrook et al., 2001. Several techniques for detecting PCR products quantitatively without electrophoresis may also be used according to the invention (see, e.g., *PCR Protocols, A Guide to Methods and Applications*, Innis et al., 1990, Academic Press, Inc. N.Y., which is hereby incorporated by reference). For example, chromatographic techniques may be employed to effect separation. There are many kinds of chromatography which may be used in the present invention: adsorption, partition, ion-exchange and molecular sieve, HPLC, and many specialized techniques for using them including column, paper, thin-layer and gas chromatography (Freifelder, *Physical Biochemistry Applications to Biochemistry and Molecular Biology*, 2nd ed., Wm. Freeman and Co., New York, N.Y., 1982, which is hereby incorporated by reference).

[0227] Another example of a separation methodology is to covalently label the oligonucleotide primers used in a PCR reaction with various types of small molecule ligands. In one such separation, a different ligand is present on each oligonucleotide. A molecule, perhaps an antibody or avidin if the ligand is biotin, that specifically binds to one of the ligands is used to coat the surface of a plate such as a 96 well ELISA plate. Upon application of the PCR reactions to the surface of such a prepared plate, the PCR products are bound with specificity to the surface. After washing the plate to remove unbound reagents, a solution containing a second molecule that binds to the first ligand is added. This second molecule is linked to some kind of reporter system. The second molecule only binds to the plate if a PCR product has been produced

whereby both oligonucleotide primers are incorporated into the final PCR products. The amount of the PCR product is then detected and quantified in a commercial plate reader much as ELISA reactions are detected and quantified. An ELISA-like system such as the one described here has been developed by Raggio Italgene (under the C-Track tradename).

[0228] Amplification products should be visualized in order to confirm amplification of the nucleic acid sequences of interest, i.e., nucleic acid sequences of one or more of the genes described herein (e.g., a gene listed in Table 30, Table I, Table J, or Table K). One typical visualization method involves staining of a gel with ethidium bromide and visualization under UV light. Alternatively, if the amplification products are integrally labeled with radio- or fluorometrically-labeled nucleotides, the amplification products may then be exposed to x-ray film or visualized under the appropriate stimulating spectra, following separation.

[0229] In one embodiment, visualization is achieved indirectly. Following separation of amplification products, a labeled, nucleic acid probe is brought into contact with the amplified nucleic acid sequence of interest, i.e., nucleic acid sequences of one or more of the genes described herein (e.g., a gene listed in Table 30, Table I, Table J, or Table K). The probe preferably is conjugated to a chromophore but may be radiolabeled. In another embodiment, the probe is conjugated to a binding partner, such as an antibody or biotin, where the other member of the binding pair carries a detectable moiety.

[0230] In another embodiment, detection is by Southern blotting and hybridization with a labeled probe. The techniques involved in Southern blotting are well known to those of skill in the art and may be found in many standard books on molecular protocols. See Sambrook et al., 2001. Briefly, amplification products are separated by gel electrophoresis. The gel is then contacted with a membrane, such as nitrocellulose, permitting transfer of the nucleic acid and non-covalent binding. Subsequently, the membrane is incubated with a chromophore-conjugated probe that is capable of hybridizing with a target amplification product. Detection is by exposure of the membrane to x-ray film or ion-emitting detection devices. One example of the foregoing is described in U.S. Pat. No. 5,279,721, incorporated by reference herein, which discloses an apparatus and method for the automated electrophoresis and transfer of nucleic acids. The apparatus permits electrophoresis and blotting without external manipulation of the gel and is ideally suited to carrying out methods according to the present invention.

5.4.1.3 Nuclease Protection Assays

[0231] In particular embodiments, feature values for biomarkers in a biomarker profile can be obtained by performing nuclease protection assays (including both ribonuclease protection assays and S1 nuclease assays) to detect and quantify specific mRNAs (e.g., mRNAs of a gene described in Table 30, Table I, Table J, or Table K). Such assays are described in, for example, Sambrook et al., 2001, *supra*. In nuclease protection assays, an antisense probe (labeled with, e.g., radio-labeled or nonisotopic) hybridizes in solution to an RNA sample. Following hybridization, single-stranded, unhybridized probe and RNA are degraded by nucleases. An acrylamide gel is used to separate the remaining protected fragments. Typically, solution hybridization is more efficient than membrane-based hybridization, and it can accommodate up to 100 μ g of sample RNA, compared with the 20-30 μ g maximum of blot hybridizations.

[0232] The ribonuclease protection assay, which is the most common type of nuclease protection assay, requires the use of RNA probes. Oligonucleotides and other single-stranded DNA probes can only be used in assays containing S1 nuclease. The single-stranded, antisense probe must typically be completely homologous to target RNA to prevent cleavage of the probe:target hybrid by nuclease.

5.4.1.4 Northern Blot Assays

[0233] Any hybridization technique known to those of skill in the art can be used to generate feature values for biomarkers in a biomarker profile. In other particular embodiments, feature values for biomarkers in a biomarker profile can be obtained by Northern blot analysis (to detect and quantify specific RNA molecules (e.g., RNAs of a gene described in Table 30, Table I, Table J, or Table K). A standard Northern blot assay can be used to ascertain an RNA transcript size, identify alternatively spliced RNA transcripts, and the relative amounts of one or more genes described herein (in particular, mRNA) in a sample, in accordance with conventional Northern hybridization techniques known to those persons of ordinary skill in the art. In Northern blots, RNA samples are first separated by size via electrophoresis in an agarose gel under denaturing conditions. The RNA is then transferred to a membrane, crosslinked and hybridized with a labeled probe. Nonisotopic or high specific activity radiolabeled probes can be used including random-primed, nick-translated, or PCR-generated DNA probes, in vitro transcribed RNA probes, and oligonucleotides. Additionally, sequences with only partial homology (e.g., cDNA from a different species or genomic DNA fragments that might contain an exon) may be used as probes. The labeled probe, e.g., a radiolabeled cDNA, either containing the full-length, single stranded DNA or a fragment of that DNA sequence may be at least 20, at least 30, at least 50, or at least 100 consecutive nucleotides in length. The probe can be labeled by any of the many different methods known to those skilled in this art. The labels most commonly employed for these studies are radioactive elements, enzymes, chemicals that fluoresce when exposed to ultraviolet light, and others. A number of fluorescent materials are known and can be utilized as labels. These include, but are not limited to, fluorescein, rhodamine, auramine, Texas Red, AMCA blue and Lucifer Yellow. The radioactive label can be detected by any of the currently available counting procedures. Non-limiting examples of isotopes include ^3H , ^{14}C , ^{32}P , ^{35}S , ^{36}Cl , ^{51}Cr , ^{57}Co , ^{58}Co , ^{59}Fe , ^{90}Y , ^{125}I , ^{131}I , and ^{186}Re . Enzyme labels are likewise useful, and can be detected by any of the presently utilized colorimetric, spectrophotometric, fluorospectrophotometric, amperometric or gasometric techniques. The enzyme is conjugated to the selected particle by reaction with bridging molecules such as carbodiimides, diisocyanates, glutaraldehyde and the like. Any enzymes known to one of skill in the art can be utilized. Examples of such enzymes include, but are not limited to, peroxidase, beta-D-galactosidase, urease, glucose oxidase plus peroxidase and alkaline phosphatase. U.S. Pat. Nos. 3,654,090, 3,850,752, and 4,016,043 are referred to by way of example for their disclosure of alternate labeling material and methods.

5.4.2 Methods of Detecting Proteins

[0234] In specific embodiments of the invention, feature values of biomarkers in a biomarker profile can be obtained

by detecting proteins, for example, by detecting the expression product (e.g., a nucleic acid or protein) of one or more genes described herein (e.g., a gene listed in Table 30, Table I, Table J, or Table K), or post-translationally modified, or otherwise modified, or processed forms of such proteins. In a specific embodiment, a biomarker profile is generated by detecting and/or analyzing one or more proteins and/or discriminating fragments thereof expressed from a gene disclosed herein (e.g., a gene listed in Table 30, Table I, Table J, or Table K) using any method known to those skilled in the art for detecting proteins including, but not limited to protein microarray analysis, immunohistochemistry and mass spectrometry.

[0235] Standard techniques may be utilized for determining the amount of the protein or proteins of interest (e.g., proteins expressed from genes listed in Table 30, Table I, Table J, or Table K) present in a sample. For example, standard techniques can be employed using, e.g., immunoassays such as, for example Western blot, immunoprecipitation followed by sodium dodecyl sulfate polyacrylamide gel electrophoresis, (SDS-PAGE), immunocytochemistry, and the like to determine the amount of protein or proteins of interest present in a sample. One exemplary agent for detecting a protein of interest is an antibody capable of specifically binding to a protein of interest, preferably an antibody detectably labeled, either directly or indirectly.

[0236] For such detection methods, if desired a protein from the sample to be analyzed can easily be isolated using techniques which are well known to those of skill in the art. Protein isolation methods can, for example, be such as those described in Harlow and Lane, 1988, *Antibodies: A Laboratory Manual*, Cold Spring Harbor Laboratory Press (Cold Spring Harbor, N.Y.), which is incorporated by reference herein in its entirety.

[0237] In certain embodiments, methods of detection of the protein or proteins of interest involve their detection via interaction with a protein-specific antibody. For example, antibodies directed to a protein of interest (e.g., a protein expressed from a gene described herein, e.g., a protein listed in Table 30, Table I, Table J, or Table K). Antibodies can be generated utilizing standard techniques well known to those of skill in the art. In specific embodiments, antibodies can be polyclonal, or more preferably, monoclonal. An intact antibody, or an antibody fragment (e.g., scFv, Fab or F(ab')₂) can, for example, be used.

[0238] For example, antibodies, or fragments of antibodies, specific for a protein of interest can be used to quantitatively or qualitatively detect the presence of a protein. This can be accomplished, for example, by immunofluorescence techniques. Antibodies (or fragments thereof) can, additionally, be employed histologically, as in immunofluorescence or immunoelectron microscopy, for in situ detection of a protein of interest. In situ detection can be accomplished by removing a biological sample (e.g., a biopsy specimen) from a patient, and applying thereto a labeled antibody that is directed to a protein of interest (e.g., a protein expressed from a gene in Table 30, Table I, Table J, or Table K). The antibody (or fragment) is preferably applied by overlaying the antibody (or fragment) onto a biological sample. Through the use of such a procedure, it is possible to determine not only the presence of the protein of interest, but also its distribution, in a particular sample. A wide variety of well-known histological methods (such as staining procedures) can be utilized to achieve such in situ detection.

[0239] Immunoassays for a protein of interest typically comprise incubating a biological sample of a detectably labeled antibody capable of identifying a protein of interest, and detecting the bound antibody by any of a number of techniques well-known in the art. As discussed in more detail, below, the term “labeled” can refer to direct labeling of the antibody via, e.g., coupling (i.e., physically linking) a detectable substance to the antibody, and can also refer to indirect labeling of the antibody by reactivity with another reagent that is directly labeled. Examples of indirect labeling include detection of a primary antibody using a fluorescently labeled secondary antibody.

[0240] The biological sample can be brought in contact with and immobilized onto a solid phase support or carrier such as nitrocellulose, or other solid support which is capable of immobilizing cells, cell particles or soluble proteins. The support can then be washed with suitable buffers followed by treatment with the detectably labeled fingerprint gene-specific antibody. The solid phase support can then be washed with the buffer a second time to remove unbound antibody. The amount of bound label on solid support can then be detected by conventional methods.

[0241] By “solid phase support or carrier” is intended any support capable of binding an antigen or an antibody. Well-known supports or carriers include glass, polystyrene, polypropylene, polyethylene, dextran, nylon, amylases, natural and modified celluloses, polyacrylamides and magnetite. The nature of the carrier can be either soluble to some extent or insoluble for the purposes of the present invention. The support material can have virtually any possible structural configuration so long as the coupled molecule is capable of binding to an antigen or antibody. Thus, the support configuration can be spherical, as in a bead, or cylindrical, as in the inside surface of a test tube, or the external surface of a rod. Alternatively, the surface can be flat such as a sheet, test strip, etc. Preferred supports include polystyrene beads. Those skilled in the art will know many other suitable carriers for binding antibody or antigen, or will be able to ascertain the same by use of routine experimentation.

[0242] One of the ways in which an antibody specific for a protein of interest can be detectably labeled is by linking the same to an enzyme and use in an enzyme immunoassay (EIA) (Voller, 1978, “The Enzyme Linked Immunosorbent Assay (ELISA)”, Diagnostic Horizons 2:1-7, Microbiological Associates Quarterly Publication, Walkersville, Md.; Voller et al., 1978, J. Clin. Pathol. 31:507-520; Butler, J. E., 1981, Meth. Enzymol. 73:482-523; Maggio (ed.), 1980, *Enzyme Immunoassay*, CRC Press, Boca Raton, Fla.; Ishikawa et al., (eds.), 1981, *Enzyme Immunoassay*, Kigaku Shoin, Tokyo, each of which is hereby incorporated by reference in its entirety). The enzyme which is bound to the antibody will react with an appropriate substrate, preferably a chromogenic substrate, in such a manner as to produce a chemical moiety which can be detected, for example, by spectrophotometric, fluorimetric or by visual means. Enzymes which can be used to detectably label the antibody include, but are not limited to, malate dehydrogenase, staphylococcal nuclease, delta-5-steroid isomerase, yeast alcohol dehydrogenase, alpha-glycerophosphate, dehydrogenase, triose phosphate isomerase, horseradish peroxidase, alkaline phosphatase, asparaginase, glucose oxidase, beta-galactosidase, ribonuclease, urease, catalase, glucose-6-phosphate dehydrogenase, glucoamylase and acetylcholinesterase. The detection can be accomplished by colorimetric methods which employ a chromogenic sub-

strate for the enzyme. Detection can also be accomplished by visual comparison of the extent of enzymatic reaction of a substrate in comparison with similarly prepared standards.

[0243] Detection can also be accomplished using any of a variety of other immunoassays. For example, by radioactively labeling the antibodies or antibody fragments, it is possible to detect a protein of interest through the use of a radioimmunoassay (RIA) (see, for example, Weintraub, 1986, *Principles of Radioimmunoassays*, Seventh Training Course on Radioligand Assay Techniques, The Endocrine Society, which is hereby incorporated by reference herein). The radioactive isotope (e.g., ^{125}I , ^{131}I , ^{35}S or ^3H) can be detected by such means as the use of a gamma isotope (e.g., counter or a scintillation counter or by autoradiography).

[0244] It is also possible to label the antibody with a fluorescent compound. When the fluorescently labeled antibody is exposed to light of the proper wavelength, its presence can then be detected due to fluorescence. Among the most commonly used fluorescent labeling compounds are fluorescein isothiocyanate, rhodamine, phycoerythrin, phycocyanin, allophycocyanin, o-phthaldehyde and fluorescamine.

[0245] The antibody can also be detectably labeled using fluorescence emitting metals such as ^{152}Eu , or others of the lanthanide series. These metals can be attached to the antibody using such metal chelating groups as diethylenetriaminepentaacetic acid (DTPA) or ethylenediaminetetraacetic acid (EDTA).

[0246] The antibody also can be detectably labeled by coupling it to a chemiluminescent compound. The presence of the chemiluminescent-tagged antibody is then determined by detecting the presence of luminescence that arises during the course of a chemical reaction. Examples of particularly useful chemiluminescent labeling compounds are luminol, isoluminol, thermatic acridinium ester, imidazole, acridinium salt and oxalate ester.

[0247] Likewise, a bioluminescent compound can be used to label the antibody of the present invention. Bioluminescence is a type of chemiluminescence found in biological systems in, which a catalytic protein increases the efficiency of the chemiluminescent reaction. The presence of a bioluminescent protein is determined by detecting the presence of luminescence. Important bioluminescent compounds for purposes of labeling are luciferin, luciferase and aequorin.

[0248] In another embodiment, specific binding molecules other than antibodies, such as aptamers, may be used to bind the biomarkers. In yet another embodiment, the biomarker profile may comprise a measurable aspect of an infectious agent (e.g., lipopolysaccharides or viral proteins) or a component thereof.

[0249] In some embodiments, a protein chip assay (e.g., The ProteinChip® Biomarker System, Ciphergen, Fremont, Calif.) is used to measure feature values for the biomarkers in the biomarker profile. See also, for example, Lin, 2004, *Modern Pathology*, 1-9; Li, 2004, *Journal of Urology* 171, 1782-1787; Wadsworth, 2004, *Clinical Cancer Research*, 10, 1625-1632; Prieto, 2003, *Journal of Liquid Chromatography & Related Technologies* 26, 2315-2328; Coombes, 2003, *Clinical Chemistry* 49, 1615-1623; Mian, 2003, *Proteomics* 3, 1725-1737; Lehre et al., 2003, *BJU International* 92, 223-225; and Diamond, 2003, *Journal of the American Society for Mass Spectrometry* 14, 760-765, each of which is hereby incorporated by reference in its entirety.

[0250] In some embodiments, a bead assay is used to measure feature values for the biomarkers in the biomarker profile.

file. One such bead assay is the Becton Dickinson Cytometric Bead Array (CBA). CBA employs a series of particles with discrete fluorescence intensities to simultaneously detect multiple soluble analytes. CBA is combined with flow cytometry to create a multiplexed assay. The Becton Dickinson CBA system, as embodied for example in the Becton Dickinson Human Inflammation Kit, uses the sensitivity of amplified fluorescence detection by flow cytometry to measure soluble analytes in a particle-based immunoassay. Each bead in a CBA provides a capture surface for a specific protein and is analogous to an individually coated well in an ELISA plate. The BD CBA capture bead mixture is in suspension to allow for the detection of multiple analytes in a small volume sample.

[0251] In some embodiments the multiplex analysis method described in U.S. Pat. No. 5,981,180 ("the '180 patent"), herein incorporated by reference in its entirety, and in particular for its teachings of the general methodology, bead technology, system hardware and antibody detection, is used to measure feature values for the biomarkers in a biomarker profile. For this analysis, a matrix of microparticles is synthesized, where the matrix consists of different sets of microparticles. Each set of microparticles can have thousands of molecules of a distinct antibody capture reagent immobilized on the microparticle surface and can be color-coded by incorporation of varying amounts of two fluorescent dyes. The ratio of the two fluorescent dyes provides a distinct emission spectrum for each set of microparticles, allowing the identification of a microparticle a set following the pooling of the various sets of microparticles. U.S. Pat. Nos. 6,268,222 and 6,599,331 also are incorporated herein by reference in their entirety, and in particular for their teachings of various methods of labeling microparticles for multiplex analysis.

5.4.3 Use of Other Methods of Detection

[0252] In some embodiments, a separation method may be used determine feature values for biomarkers in a biomarker profile, such that only a subset of biomarkers within the sample is analyzed. For example, the biomarkers that are analyzed in a sample may be mRNA species from a cellular extract which has been fractionated to obtain only the nucleic acid biomarkers within the sample, or the biomarkers may be from a fraction of the total complement of proteins within the sample, which have been fractionated by chromatographic techniques.

[0253] Feature values for biomarkers in a biomarker profile can also, for example, be generated by the use of one or more of the following methods described below. For example, methods may include nuclear magnetic resonance (NMR) spectroscopy, a mass spectrometry method, such as electrospray ionization mass spectrometry (ESI-MS), ESI-MS/MS, ESI-MS/(MS)ⁿ (n is an integer greater than zero), matrix-assisted laser desorption/ionization time-of-flight mass spectrometry (MALDI-TOF-MS), surface-enhanced laser desorption/ionization time-of-flight mass spectrometry (SELDI-TOF-MS), desorption/ionization on silicon (DIOS), secondary ion mass spectrometry (SIMS), quadrupole time-of-flight (Q-TOF), atmospheric pressure chemical ionization mass spectrometry (APCI-MS), APCI-MS/MS, APCI-(MS)ⁿ, atmospheric pressure photoionization mass spectrometry (APPI-MS), APPI-MS/MS, and APPI-(MS)ⁿ. Other mass spectrometry methods may include, inter alia, quadrupole, Fourier transform mass spectrometry (FTMS) and ion trap. Other suitable methods may include chemical extraction par-

tioning, column chromatography, ion exchange chromatography, hydrophobic (reverse phase) liquid chromatography, isoelectric focusing, one-dimensional polyacrylamide gel electrophoresis (PAGE), two-dimensional polyacrylamide gel electrophoresis (2D-PAGE) or other chromatography, such as thin-layer, gas or liquid chromatography, or any combination thereof. In one embodiment, the biological sample may be fractionated prior to application of the separation method.

[0254] In one embodiment, laser desorption/ionization time-of-flight mass spectrometry is used to create determine feature values in a biomarker profile where the biomarkers are proteins or protein fragments that have been ionized and vaporized off an immobilizing support by incident laser radiation and the feature values are the presence or absence of peaks representing these fragments in the mass spectra profile. A variety of laser desorption/ionization techniques are known in the art (see, e.g., Guttman et al., 2001, *Anal. Chem.* 73:1252-62 and Wei et al., 1999, *Nature* 399:243-246, each of which is hereby incorporated by herein be reference in its entirety).

[0255] Laser desorption/ionization time-of-flight mass spectrometry allows the generation of large amounts of information in a relatively short period of time. A biological sample is applied to one of several varieties of a support that binds all of the biomarkers, or a subset thereof, in the sample. Cell lysates or samples are directly applied to these surfaces in volumes as small as 0.5 μ L, with or without prior purification or fractionation. The lysates or sample can be concentrated or diluted prior to application onto the support surface. Laser desorption/ionization is then used to generate mass spectra of the sample, or samples, in as little as three hours.

5.5 DATA ANALYSIS ALGORITHMS

[0256] Biomarkers whose corresponding feature values are capable of discriminating between converters and nonconverters are identified in the present invention. The identity of these biomarkers and their corresponding features (e.g., expression levels) can be used to develop a decision rule, or plurality of decision rules, that discriminate between converters and nonconverters. Section 6 below illustrates how data analysis algorithms can be used to construct a number of such decision rules. Each of the data analysis algorithms described in Section 6 use features (e.g., expression values) of a subset of the biomarkers identified in the present invention across a training population that includes converters and nonconverters. Typically, a SIRS subject is considered a nonconverter when the subject does not develop sepsis in a defined time period (e.g., observation period). This defined time period can be, for example, twelve hours, twenty four hours, forty-eight hours, a day, a week, a month, or longer. Specific data analysis algorithms for building a decision rule, or plurality of decision rules, that discriminate between subjects that develop sepsis and subjects that do not develop sepsis during a defined period will be described in the subsections below. Once a decision rule has been built using these exemplary data analysis algorithms or other techniques known in the art, the decision rule can be used to classify a test subject into one of the two or more phenotypic classes (e.g., a converter or a nonconverter). This is accomplished by applying the decision rule to a biomarker profile obtained from the test subject. Such decision rules, therefore, have enormous value as diagnostic indicators.

[0257] The present invention provides, in one aspect, for the evaluation of a biomarker profile from a test subject to biomarker profiles obtained from a training population. In some embodiments, each biomarker profile obtained from subjects in the training population, as well as the test subject, comprises a feature for each of a plurality of different biomarkers. In some embodiments, this comparison is accomplished by (i) developing a decision rule using the biomarker profiles from the training population and (ii) applying the decision rule to the biomarker profile from the test subject. As such, the decision rules applied in some embodiments of the present invention are used to determine whether a test subject having SIRS will or will not likely acquire sepsis.

[0258] In some embodiments of the present invention, when the results of the application of a decision rule indicate that the subject will likely acquire sepsis, the subject is diagnosed as a “sepsis” subject. If the results of an application of a decision rule indicate that the subject will not acquire sepsis, the subject is diagnosed as a “SIRS” subject. Thus, in some embodiments, the result in the above-described binary decision situation has four possible outcomes:

[0259] (i) truly septic, where the decision rule indicates that the subject will acquire sepsis and the subject does in fact acquire sepsis during the definite time period (true positive, TP);

[0260] (ii) falsely septic, where the decision rule indicates that the subject will acquire sepsis and the subject, in fact, does not acquire sepsis during the definite time period (false positive, FP);

[0261] (iii) truly SIRS, where the decision rule indicates that the subject will not acquire sepsis and the subject, in fact, does not acquire sepsis during the definite time period (true negative, TN); or

[0262] (iv) falsely SIRS, where the decision rule indicates that the subject will not acquire sepsis and the subject, in fact, does acquire sepsis during the definite time period (false negative, FN).

[0263] It will be appreciated that other definitions for TP, FP, TN, FN can be made. For example, TP could have been defined as instances where the decision rule indicates that the subject will not acquire sepsis and the subject, in fact, does not acquire sepsis during the definite time period. While all such alternative definitions are within the scope of the present invention, for ease of understanding the present invention, the definitions for TP, FP, TN, and FN given by definitions (i) through (iv) above will be used herein, unless otherwise stated.

[0264] As will be appreciated by those of skill in the art, a number of quantitative criteria can be used to communicate the performance of the comparisons made between a test biomarker profile and reference biomarker profiles (e.g., the application of a decision rule to the biomarker profile from a test subject). These include positive predicted value (PPV), negative predicted value (NPV), specificity, sensitivity, accuracy, and certainty. In addition, other constructs such as receiver operator curves (ROC) can be used to evaluate decision rule performance. As used herein:

$$PPV = \frac{TP}{TP + FP}$$

$$NPV = \frac{TN}{TN + FN}$$

-continued

$$\text{specificity} = \frac{TN}{TN + FP}$$

$$\text{sensitivity} = \frac{TP}{TP + FN}$$

$$\text{accuracy} = \text{certainty} = \frac{TP + TN}{N}$$

[0265] Here, N is the number of samples compared (e.g., the number of test samples for which a determination of sepsis or SIRS is sought). For example, consider the case in which there are ten subjects for which SIRS/sepsis classification is sought. Biomarker profiles are constructed for each of the ten test subjects. Then, each of the biomarker profiles is evaluated by applying a decision rule, where the decision rule was developed based upon biomarker profiles obtained from a training population. In this example, N, from the above equations, is equal to 10. Typically, N is a number of samples, where each sample was collected from a different member of a population. This population can, in fact, be of two different types. In one type, the population comprises subjects whose samples and phenotypic data (e.g., feature values of biomarkers and an indication of whether or not the subject acquired sepsis) was used to construct or refine a decision rule. Such a population is referred to herein as a training population. In the other type, the population comprises subjects that were not used to construct the decision rule. Such a population is referred to herein as a validation population. Unless otherwise stated, the population represented by N is either exclusively a training population or exclusively a validation population, as opposed to a mixture of the two population types. It will be appreciated that scores such as accuracy will be higher (closer to unity) when they are based on a training population as opposed to a validation population. Nevertheless, unless otherwise explicitly stated herein, all criteria used to assess the performance of a decision rule (or other forms of evaluation of a biomarker profile from a test subject) including certainty (accuracy) refer to criteria that were measured by applying the decision rule corresponding to the criteria to either a training population or a validation population. Furthermore, the definitions for PPV, NPV, specificity, sensitivity, and accuracy defined above can also be found in Draghici, *Data Analysis Tools for DNA Microanalysis*, 2003, CRC Press LLC, Boca Raton, Fla., pp. 342-343, which is hereby incorporated herein by reference.

[0266] In some embodiments the training population comprises nonconverters and converters. In some embodiments, biomarker profiles are constructed from this population using biological samples collected from the training population at some time period prior to the onset of sepsis by the converters of the population. As such, for the converters of the training population, a biological sample can be collected two weeks before, one week before, four days before, three days before, one day before, or any other time period before the converters became septic. In practice, such collections are obtained by collecting a biological sample at regular time intervals after admittance into the hospital with a SIRS diagnosis. For example, in one approach, subjects who have been diagnosed with SIRS in a hospital are used as a training population. Once admitted to the hospital with SIRS, the biological samples are collected from the subjects at selected times (e.g., hourly, every eight hours, every twelve hours, daily, etc.). A

portion of the subjects acquire sepsis and a portion of the subjects do not acquire sepsis. For the subjects that acquire sepsis, the biological sample taken from the subjects just prior to the onset of sepsis are termed the T_{-12} biological samples. All other biological samples from the subjects are retroactively indexed relative to these biological samples. For instance, when a biological sample has been taken from a subject on a daily basis, the biological sample taken the day before the T_{-12} sample is referred to as the T_{-36} biological sample. Time points for biological samples for a nonconverter in the training population are identified by “time-matching” the nonconverter subject with a converter subject. To illustrate, consider the case in which a subject in the training population became clinically-defined as septic on his sixth day of enrollment. For the sake of illustration, for this subject, T_{-36} is day four of the study, and the T_{-36} biological sample is the biological sample that was obtained on day four of the study. Likewise, T_{-36} for the matched nonconverter subject is deemed to be day four of the study on this paired nonconverter subject.

[0267] In some embodiments, N is more than one, more than five, more than ten, more than twenty, between ten and 100, more than 100, or less than 1000 subjects. A decision rule (or other forms of comparison) can have at least about 99% certainty, or even more, in some embodiments, against a training population or a validation population. In other embodiments, the certainty is at least about 97%, at least about 95%, at least about 90%, at least about 85%, at least about 80%, at least about 75%, at least about 70%, at least about 65%, or at least about 60% against a training population or a validation population (and therefore against a single subject that is not part of a training population such as a clinical patient). The useful degree of certainty may vary, depending on the particular method of the present invention. As used herein, “certainty” means “accuracy.” In one embodiment, the sensitivity and/or specificity is at least about 97%, at least about 95%, at least about 90%, at least about 85%, at least about 80%, at least about 75%, or at least about 70% against a training population or a validation population. In some embodiments, such decision rules are used to predict the development of sepsis with the stated accuracy. In some embodiments, such decision rules are used to diagnose sepsis with the stated accuracy. In some embodiments, such decision rules are used to determine a stage of sepsis with the stated accuracy.

[0268] The number of features that may be used by a decision rule to classify a test subject with adequate certainty is two or more. In some embodiments, it is three or more, four or more, ten or more, or between 10 and 200. Depending on the degree of certainty sought, however, the number of features used in a decision rule can be more or less, but in all cases is at least two. In one embodiment, the number of features that may be used by a decision rule to classify a test subject is optimized to allow a classification of a test subject with high certainty.

[0269] In some of the examples in Section 6 below, microarray data abundance data was collected for a plurality of biomarkers in each subject. That is, for each biomarker in a biomarker profile, a feature, microarray abundance data for the biomarker, was measured. Decision rules are developed from such biomarker profiles from a training population using data analysis algorithms in order to predict sample phenotypes based on observed gene expression patterns. While new and microarray specific classification tools are

constantly being developed, the existing body of pattern recognition and prediction algorithms provide effective data analysis algorithms for constructing decision rules. See, for example, National Research Council; Panel on Discriminant Analysis Classification and Clustering, Discriminant Analysis and Clustering, Washington, D.C.: National Academy Press, which is hereby incorporated by reference. Furthermore, the techniques described in Dudoit et al., 2002, “Comparison of discrimination methods for the classification of tumors using gene expression data.” *JASA* 97; 77-87, hereby incorporated by reference herein in its entirety, can be used to develop such decision rules.

[0270] Relevant data analysis algorithms for developing a decision rule include, but are not limited to, discriminant analysis including linear, logistic, and more flexible discrimination techniques (see, e.g., Gnanadesikan, 1977, *Methods for Statistical Data Analysis of Multivariate Observations*, New York: Wiley 1977, which is hereby incorporated by reference herein in its entirety); tree-based algorithms such as classification and regression trees (CART) and variants (see, e.g., Breiman, 1984, *Classification and Regression Trees*, Belmont, Calif.: Wadsworth International Group, which is hereby incorporated by reference herein in its entirety, as well as Section 5.1.3, below); generalized additive models (see, e.g., Tibshirani, 1990, *Generalized Additive Models*, London: Chapman and Hall, which is hereby incorporated by reference herein in its entirety); and neural networks (see, e.g., Neal, 1996, *Bayesian Learning for Neural Networks*, New York: Springer-Verlag; and Insua, 1998, Feedforward neural networks for nonparametric regression In: *Practical Nonparametric and Semiparametric Bayesian Statistics*, pp. 181-194, New York: Springer, which is hereby incorporated by reference herein in its entirety, as well as Section 5.5.6, below).

[0271] In one embodiment, comparison of a test subject’s biomarker profile to a biomarker profiles obtained from a training population is performed, and comprises applying a decision rule. The decision rule is constructed using a data analysis algorithm, such as a computer pattern recognition algorithm. Other suitable data analysis algorithms for constructing decision rules include, but are not limited to, logistic regression (see Section 5.5.10, below) or a nonparametric algorithm that detects differences in the distribution of feature values (e.g., a Wilcoxon Signed Rank Test (unadjusted and adjusted)). The decision rule can be based upon two, three, four, five, 10, 20 or more features, corresponding to measured observables from one, two, three, four, five, 10, 20 or more biomarkers. In one embodiment, the decision rule is based on hundreds of features or more. Decision rules may also be built using a classification tree algorithm. For example, each biomarker profile from a training population can comprise at least three features, where the features are predictors in a classification tree algorithm (see Section 5.5.1, below). The decision rule predicts membership within a population (or class) with an accuracy of at least about at least about 70%, of at least about 75%, of at least about 80%, of at least about 85%, of at least about 90%, of at least about 95%, of at least about 97%, of at least about 98%, of at least about 99%, or about 100%.

[0272] Suitable data analysis algorithms are known in the art, some of which are reviewed in Hastie et al., supra. In a specific embodiment, a data analysis algorithm of the invention comprises Classification and Regression Tree (CART; Section 5.5.1, below), Multiple Additive Regression Tree (MART; Section 5.5.4, below), Prediction Analysis for

Microarrays (PAM; Section 5.5.2, below) or Random Forest analysis (Section 5.5.1, below). Such algorithms classify complex spectra from biological materials, such as a blood sample, to distinguish subjects as normal or as possessing biomarker expression levels characteristic of a particular disease state. In other embodiments, a data analysis algorithm of the invention comprises ANOVA and nonparametric equivalents, linear discriminant analysis (Section 5.5.10, below), logistic regression analysis (Section 5.5.10, below), nearest neighbor classifier analysis (Section 5.5.9, below), neural networks (Section 5.5.6, below), principal component analysis (Section 5.5.8, below), quadratic discriminant analysis (Section 5.5.11, below), regression classifiers (Section 5.5.5, below) and support vector machines (Section 5.5.12, below). While such algorithms may be used to construct a decision rule and/or increase the speed and efficiency of the application of the decision rule and to avoid investigator bias, one of ordinary skill in the art will realize that computer-based algorithms are not required to carry out the methods of the present invention.

[0273] Decision rules can be used to evaluate biomarker profiles, regardless of the method that was used to generate the biomarker profile. For example, suitable decision rules that can be used to evaluate biomarker profiles generated using gas chromatography, as discussed in Harper, "Pyrolysis and GC in Polymer Analysis," Dekker, New York (1985). Further, Wagner et al., 2002, *Anal. Chem.* 74:1824-1835 disclose a decision rule that improves the ability to classify subjects based on spectra obtained by static time-of-flight secondary ion mass spectrometry (TOF-SIMS). Additionally, Bright et al., 2002, *J. Microbiol. Methods* 48:127-38, hereby incorporated by reference herein in its entirety, disclose a method of distinguishing between bacterial strains with high certainty (79-89% correct classification rates) by analysis of MALDI-TOF-MS spectra. Dalluge, 2000, *Fresenius J. Anal. Chem.* 366:701-711, hereby incorporated by reference herein in its entirety, discusses the use of MALDI-TOF-MS and liquid chromatography-electrospray ionization mass spectrometry (LC/ESI-MS) to classify profiles of biomarkers in complex biological samples.

5.5.1 Decision Trees

[0274] One type of decision rule that can be constructed using the feature values of the biomarkers identified in the present invention is a decision tree. Here, the "data analysis algorithm" is any technique that can build the decision tree, whereas the final "decision tree" is the decision rule. A decision tree is constructed using a training population and specific data analysis algorithms. Decision trees are described generally by Duda, 2001, *Pattern Classification*, John Wiley & Sons, Inc., New York. pp. 395-396, which is hereby incorporated by reference. Tree-based methods partition the feature space into a set of rectangles, and then fit a model (like a constant) in each one.

[0275] The training population data includes the features (e.g., expression values, or some other observable) for the biomarkers of the present invention across a training set population. One specific algorithm that can be used to construct a decision tree is a classification and regression tree (CART). Other specific decision tree algorithms include, but are not limited to, ID3, C4.5, MART, and Random Forests. CART, ID3, and C4.5 are described in Duda, 2001, *Pattern Classification*, John Wiley & Sons, Inc., New York. pp. 396-408 and pp. 411-412, which is hereby incorporated by reference.

CART, MART, and C4.5 are described in Hastie et al., 2001, *The Elements of Statistical Learning*, Springer-Verlag, New York, Chapter 9, which is hereby incorporated by reference in its entirety. Random Forests are described in Breiman, 1999, "Random Forests—Random Features," Technical Report 567, Statistics Department, U.C. Berkeley, September 1999, which is hereby incorporated by reference in its entirety.

[0276] In some embodiments of the present invention, decision trees are used to classify subjects using features for combinations of biomarkers of the present invention. Decision tree algorithms belong to the class of supervised learning algorithms. The aim of a decision tree is to induce a classifier (a tree) from real-world example data. This tree can be used to classify unseen examples that have not been used to derive the decision tree. As such, a decision tree is derived from training data. Exemplary training data contains data for a plurality of subjects (the training population). For each respective subject there is a plurality of features the class of the respective subject (e.g., sepsis/SIRS). In one embodiment of the present invention, the training data is expression data for a combination of biomarkers across the training population.

[0277] The following algorithm describes an exemplary decision tree derivation:

```

Tree(Examples,Class,Features)
  Create a root node
  If all Examples have the same Class value, give the root this label
  Else if Features is empty label the root according to the most common
  value
  Else begin
    Calculate the information gain for each Feature
    Select the Feature A with highest information gain and make this
    the root
    Feature
    For each possible value, v, of this Feature
      Add a new branch below the root, corresponding to A = v
      Let Examples(v) be those examples with A = v
      If Examples(v) is empty, make the new branch a leaf node
      labeled with the most common value among Examples
      Else let the new branch be the tree created by
      Tree(Examples(v),Class,Features - {A})
  end

```

[0278] A more detailed description of the calculation of information gain is shown in the following. If the possible classes v_i of the examples have probabilities $P(v_i)$ then the information content I of the actual answer is given by:

$$I(P(v_1), \dots, P(v_n)) = \sum_{i=1}^n -P(v_i) \log_2 P(v_i)$$

[0279] The I-value shows how much information we need in order to be able to describe the outcome of a classification for the specific dataset used. Supposing that the dataset contains p positive (e.g. will develop sepsis) and n negative (e.g. will not develop sepsis) examples (e.g. subjects), the information contained in a correct answer is:

$$I\left(\frac{p}{p+n}, \frac{n}{p+n}\right) = -\frac{p}{p+n} \log_2 \frac{p}{p+n} - \frac{n}{p+n} \log_2 \frac{n}{p+n}$$

where \log_2 is the logarithm using base two. By testing single features the amount of information needed to make a correct classification can be reduced. The remainder for a specific feature A (e.g. representing a specific biomarker) shows how much the information that is needed can be reduced.

$$\text{Remainder}(A) = \sum_{i=1}^v \frac{p_i + n_i}{p + n} I\left(\frac{p_i}{p_i + n_i}, \frac{n_i}{p_i + n_i}\right)$$

“v” is the number of unique attribute values for feature A in a certain dataset, “i” is a certain attribute value, “p_i” is the number of examples for feature A where the classification is positive (e.g. will develop sepsis), “n_i” is the number of examples for feature A where the classification is negative (e.g. will not develop sepsis).

[0280] The information gain of a specific feature A is calculated as the difference between the information content for the classes and the remainder of feature A:

$$\text{Gain}(A) = I\left(\frac{p}{p + n}, \frac{n}{p + n}\right) - \text{Remainder}(A)$$

The information gain is used to evaluate how important the different features are for the classification (how well they split up the examples), and the feature with the highest information.

[0281] In general there are a number of different decision tree algorithms, many of which are described in Duda, Pattern Classification, Second Edition, 2001, John Wiley & Sons, Inc. Decision tree algorithms often require consideration of feature processing, impurity measure, stopping criterion, and pruning. Specific decision tree algorithms include, but are not limited to classification and regression trees (CART), multivariate decision trees, ID3, and C4.5.

[0282] In one approach, when a decision tree is used, the gene expression data for a select combination of genes described in the present invention across a training population is standardized to have mean zero and unit variance. The members of the training population are randomly divided into a training set and a test set. For example, in one embodiment, two thirds of the members of the training population are placed in the training set and one third of the members of the training population are placed in the test set. The expression values for a select combination of biomarkers described in the present invention is used to construct the decision tree. Then, the ability for the decision tree to correctly classify members in the test set is determined. In some embodiments, this computation is performed several times for a given combination of biomarkers. In each computational iteration, the members of the training population are randomly assigned to the training set and the test set. Then, the quality of the combination of biomarkers is taken as the average of each such iteration of the decision tree computation.

[0283] In addition to univariate decision trees in which each split is based on a feature value for a corresponding biomarker, among the set of biomarkers of the present invention, or the relative feature values of two such biomarkers, multivariate decision trees can be implemented as a decision rule. In such multivariate decision trees, some or all of the decisions actually comprise a linear combination of feature values for a plurality of biomarkers of the present invention. Such a linear

combination can be trained using known techniques such as gradient descent on a classification or by the use of a sum-squared-error criterion. To illustrate such a decision tree, consider the expression:

$$0.04x_1 + 0.16x_2 < 500$$

[0284] Here, x₁ and x₂ refer to two different features for two different biomarkers from among the biomarkers of the present invention. To poll the decision rule, the values of features x₁ and x₂ are obtained from the measurements obtained from the unclassified subject. These values are then inserted into the equation. If a value of less than 500 is computed, then a first branch in the decision tree is taken. Otherwise, a second branch in the decision tree is taken. Multivariate decision trees are described in Duda, 2001, *Pattern Classification*, John Wiley & Sons, Inc., New York, pp. 408-409, which is hereby incorporated by reference.

[0285] Another approach that can be used in the present invention is multivariate adaptive regression splines (MARS). MARS is an adaptive procedure for regression, and is well suited for the high-dimensional problems addressed by the present invention. MARS can be viewed as a generalization of stepwise linear regression or a modification of the CART method to improve the performance of CART in the regression setting. MARS is described in Hastie et al., 2001, *The Elements of Statistical Learning*, Springer-Verlag, New York, pp. 283-295, which is hereby incorporated by reference in its entirety.

5.5.2 Predictive Analysis of Microarrays (PAM)

[0286] One approach to developing a decision rule using feature values of biomarkers of the present invention is the nearest centroid classifier. Such a technique computes, for each class (sepsis and SIRS), a centroid given by the average feature levels of the biomarkers in the class, and then assigns new samples to the class whose centroid is nearest. This approach is similar to k-means clustering except clusters are replaced by known classes. This algorithm can be sensitive to noise when a large number of biomarkers are used. One enhancement to the technique uses shrinkage: for each biomarker, differences between class centroids are set to zero if they are deemed likely to be due to chance. This approach is implemented in the Prediction Analysis of Microarray, or PAM. See, for example, Tibshirani et al., 2002, *Proceedings of the National Academy of Science USA* 99; 6567-6572, which is hereby incorporated by reference in its entirety. Shrinkage is controlled by a threshold below which differences are considered noise. Biomarkers that show no difference above the noise level are removed. A threshold can be chosen by cross-validation. As the threshold is decreased, more biomarkers are included and estimated classification errors decrease, until they reach a bottom and start climbing again as a result of noise biomarkers—a phenomenon known as overfitting.

5.5.3 Bagging, Boosting, and the Random Subspace Method

[0287] Bagging, boosting, the random subspace method, and additive trees are data analysis algorithms known as combining techniques that can be used to improve weak decision rules. These techniques are designed for, and usually applied to, decision trees, such as the decision trees described in Section 5.5.1, above. In addition, such techniques can also

be useful in decision rules developed using other types of data analysis algorithms such as linear discriminant analysis.

[0288] In bagging, one samples the training set, generating random independent bootstrap replicates, constructs the decision rule on each of these, and aggregates them by a simple majority vote in the final decision rule. See, for example, Breiman, 1996, *Machine Learning* 24, 123-140; and Efron & Tibshirani, *An Introduction to Bootstrap*, Chapman & Hall, New York, 1993, which is hereby incorporated by reference in its entirety.

[0289] In boosting, decision rules are constructed on weighted versions of the training set, which are dependent on previous classification results. Initially, all features under consideration have equal weights, and the first decision rule is constructed on this data set. Then, weights are changed according to the performance of the decision rule. Erroneously classified features get larger weights, and the next decision rule is boosted on the reweighted training set. In this way, a sequence of training sets and decision rules is obtained, which is then combined by simple majority voting or by weighted majority voting in the final decision rule. See, for example, Freund & Schapire, "Experiments with a new boosting algorithm," *Proceedings 13th International Conference on Machine Learning*, 1996, 148-156, which is hereby incorporated by reference in its entirety.

[0290] To illustrate boosting, consider the case where there are two phenotypes exhibited by the population under study, phenotype 1 (e.g., acquiring sepsis during a defined time period), and phenotype 2 (e.g., SIRS only, meaning that the subject does acquire sepsis within a defined time period). Given a vector of predictor biomarkers (e.g., a vector of features that represent such biomarkers) from the training set data, a decision rule $G(X)$ produces a prediction taking one of the type values in the two value set: {phenotype 1, phenotype 2}. The error rate on the training sample is

$$\overline{err} = \frac{1}{N} \sum_{i=1}^N I(y_i \neq G(x_i))$$

[0291] where N is the number of subjects in the training set (the sum total of the subjects that have either phenotype 1 or phenotype 2). For example, if there are 49 organisms that acquire sepsis and 72 organisms that remain in the SIRS state, N is 121. A weak decision rule is one whose error rate is only slightly better than random guessing. In the boosting algorithm, the weak decision rule is repeatedly applied to modified versions of the data, thereby producing a sequence of weak decision rules $G_m(x)$, $m, =1, 2, \dots, M$. The predictions from all of the decision rules in this sequence are then combined through a weighted majority vote to produce the final decision rule:

$$G(x) = \text{sign} \left(\sum_{m=1}^M \alpha_m G_m(x) \right)$$

[0292] Here $\alpha_1, \alpha_2, \dots, \alpha_M$ are computed by the boosting algorithm and their purpose is to weigh the contribution of each respective decision rule $G_m(x)$. Their effect is to give higher influence to the more accurate decision rules in the sequence.

[0293] The data modifications at each boosting step consist of applying weights $w_1, w_2, w_r,$ to each of the training observations $(x_i, Y_i), i=1, 2, \dots, N$. Initially all the weights are set to $w_i=1/N$, so that the first step simply trains the decision rule on the data in the usual manner. For each successive iteration $m=2, 3, \dots, M$ the observation weights are individually modified and the decision rule is reapplied to the weighted observations. At step m , those observations that were misclassified by the decision rule $G_{m-1}(x)$ induced at the previous step have their weights increased, whereas the weights are decreased for those that were classified correctly. Thus as iterations proceed, observations that are difficult to correctly classify receive ever-increasing influence. Each successive decision rule is thereby forced to concentrate on those training observations that are missed by previous ones in the sequence.

[0294] The exemplary boosting algorithm is summarized as follows:

-
1. Initialize the observation weights $w_i = 1/N, i = 1, 2, \dots, N$.
 2. For $m = 1$ to M :
 - (a) Fit a decision rule $G_m(x)$ to the training set using weights w_i .
 - (b) Compute

$$err_m = \frac{\sum_{i=1}^N w_i I(y_i \neq G_m(x_i))}{\sum_{i=1}^N w_i}$$

- (c) Compute $\alpha_m = \log((1-err_m)/err_m)$.
- (d) Set $w_i \leftarrow w_i \cdot \exp[\alpha_m \cdot I(y_i \neq G_m(x_i))], i = 1, 2, \dots, N$.

3. Output $G(x) = \text{sign} \left[\sum_{m=1}^M \alpha_m G_m(x) \right]$

[0295] In one embodiment in accordance with this algorithm, each object is, in fact, a factor. Furthermore, in the algorithm, the current decision rule $G_m(x)$ is induced on the weighted observations at line 2a. The resulting weighted error rate is computed at line 2b. Line 2c calculates the weight α_m given to $G_m(x)$ in producing the final classifier $G(x)$ (line 3). The individual weights of each of the observations are updated for the next iteration at line 2d. Observations misclassified by $G_m(x)$ have their weights scaled by a factor $\exp(\alpha_m)$, increasing their relative influence for inducing the next classifier $G_{m+1}(x)$ in the sequence. In some embodiments, modifications of the Freund and Schapire, 1997, *Journal of Computer and System Sciences* 55, pp. 119-139, boosting methods are used. See, for example, Hasti et al., *The Elements of Statistical Learning*, 2001, Springer, N.Y., Chapter 10, which is hereby incorporated by reference in its entirety. For example, in some embodiments, feature preselection is performed using a technique such as the nonparametric scoring methods of Park et al., 2002, *Pac. Symp. Biocomput.* 6, 52-63, which is hereby incorporated by reference in its entirety. Feature preselection is a form of dimensionality reduction in which the genes that discriminate between classifications the best are selected for use in the classifier. Then, the LogitBoost procedure introduced by Friedman et al., 2000, *Ann Stat* 28, 337-407 is used rather than the boosting procedure of Freund and Schapire. In some embodiments, the boosting and other classification methods of Ben-Dor et al., 2000, *Journal of Computational Biology* 7,

559-583, hereby incorporated by reference in its entirety, are used in the present invention. In some embodiments, the boosting and other classification methods of Freund and Schapire, 1997, *Journal of Computer and System Sciences* 55, 119-139, hereby incorporated by reference in its entirety, are used.

[0296] In the random subspace method, decision rules are constructed in random subspaces of the data feature space. These decision rules are usually combined by simple majority voting in the final decision rule. See, for example, Ho, "The Random subspace method for constructing decision forests," *IEEE Trans Pattern Analysis and Machine Intelligence*, 1998; 20(8): 832-844, which is hereby incorporated by reference in its entirety.

5.5.4 Multiple Additive Regression Trees

[0297] Multiple additive regression trees (MART) represents another way to construct a decision rule that can be used in the present invention. A generic algorithm for MART is:

1. Initialize $f_0(x) = \operatorname{argmin}_{\gamma} \sum_{i=1}^N L(y_i, \gamma)$.

2. For $m = 1$ to M :
 (a) For $I = 1, 2, \dots, N$ compute

$$r_{im} = - \left[\frac{\partial L(y_i, f(x_i))}{\partial f(x_i)} \right]_{f=f_{m-1}}$$

(b) Fit a regression tree to the targets r_{im} giving terminal regions R_{jm} , $j = 1, 2, \dots, J_m$.

(c) For $j = 1, 2, \dots, J_m$ compute

$$\gamma_{jm} = \operatorname{argmin}_{\gamma} \sum_{x_i \in R_{jm}} L(y_i, f_{m-1}(x_i) + \gamma).$$

(d) Update $f_m(x) = f_{m-1}(x) + \sum_{j=1}^{J_m} \gamma_{jm} I(x \in R_{jm})$

3. Output $\hat{f}(x) = f_M(x)$.

[0298] Specific algorithms are obtained by inserting different loss criteria $L(y, f(x))$. The first line of the algorithm initializes to the optimal constant model, which is just a single terminal node tree. The components of the negative gradient computed in line 2(a) are referred to as generalized pseudo residuals, r . Gradients for commonly used loss functions are summarized in Table 10.2, of Hastie et al., 2001, *The Elements of Statistical Learning*, Springer-Verlag, New York, p. 321, which is hereby incorporated by reference. The algorithm for classification is similar and is described in Hastie et al., Chapter 10, which is hereby incorporated by reference in its entirety. Tuning parameters associated with the MART procedure are the number of iterations M and the sizes of each of the constituent trees J_m , $m=1, 2, \dots, M$.

5.5.5 Decision Rules Derived by Regression

[0299] In some embodiments, a decision rule used to classify subjects is built using regression. In such embodiments, the decision rule can be characterized as a regression classifier, preferably a logistic regression classifier. Such a regres-

sion classifier includes a coefficient for each of the biomarkers (e.g., a feature for each such biomarker) used to construct the classifier. In such embodiments, the coefficients for the regression classifier are computed using, for example, a maximum likelihood approach. In such a computation, the features for the biomarkers (e.g., RT-PCR, microarray data) is used. In particular embodiments, molecular marker data from only two trait subgroups is used (e.g., trait subgroup a: will acquire sepsis in a defined time period and trait subgroup b: will not acquire sepsis in a defined time period) and the dependent variable is absence or presence of a particular trait in the subjects for which biomarker data is available.

[0300] In another specific embodiment, the training population comprises a plurality of trait subgroups (e.g., three or more trait subgroups, four or more specific trait subgroups, etc.). These multiple trait subgroups can correspond to discrete stages in the phenotypic progression from healthy, to SIRS, to sepsis, to more advanced stages of sepsis in a training population. In this specific embodiment, a generalization of the logistic regression model that handles multicategory responses can be used to develop a decision that discriminates between the various trait subgroups found in the training population. For example, measured data for selected molecular markers can be applied to any of the multi-category logit models described in Agresti, *An Introduction to Categorical Data Analysis*, 1996, John Wiley & Sons, Inc., New York, Chapter 8, hereby incorporated by reference in its entirety, in order to develop a classifier capable of discriminating between any of a plurality of trait subgroups represented in a training population.

5.5.6 Neural Networks

[0301] In some embodiments, the feature data measured for select biomarkers of the present invention (e.g., RT-PCR data, mass spectrometry data, microarray data) can be used to train a neural network. A neural network is a two-stage regression or classification decision rule. A neural network has a layered structure that includes a layer of input units (and the bias) connected by a layer of weights to a layer of output units. For regression, the layer of output units typically includes just one output unit. However, neural networks can handle multiple quantitative responses in a seamless fashion.

[0302] In multilayer neural networks, there are input units (input layer), hidden units (hidden layer), and output units (output layer). There is, furthermore, a single bias unit that is connected to each unit other than the input units. Neural networks are described in Duda et al., 2001, *Pattern Classification*, Second Edition, John Wiley & Sons, Inc., New York; and Hastie et al., 2001, *The Elements of Statistical Learning*, Springer-Verlag, New York, each of which is hereby incorporated by reference in its entirety. Neural networks are also described in Draghici, 2003, *Data Analysis Tools for DNA Microarrays*, Chapman & Hall/CRC; and Mount, 2001, *Bioinformatics: sequence and genome analysis*, Cold Spring Harbor Laboratory Press, Cold Spring Harbor, N.Y., each of which is hereby incorporated by reference in its entirety. What is disclosed below is some exemplary forms of neural networks.

[0303] The basic approach to the use of neural networks is to start with an untrained network, present a training pattern to the input layer, and to pass signals through the net and determine the output at the output layer. These outputs are then compared to the target values; any difference corresponds to an error. This error or criterion function is some

scalar function of the weights and is minimized when the network outputs match the desired outputs. Thus, the weights are adjusted to reduce this measure of error. For regression, this error can be sum-of-squared errors. For classification, this error can be either squared error or cross-entropy (deviation). See, e.g., Hastie et al., 2001, *The Elements of Statistical Learning*, Springer-Verlag, New York, which is hereby incorporated by reference in its entirety.

[0304] Three commonly used training protocols are stochastic, batch, and on-line. In stochastic training, patterns are chosen randomly from the training set and the network weights are updated for each pattern presentation. Multilayer nonlinear networks trained by gradient descent methods such as stochastic back-propagation perform a maximum-likelihood estimation of the weight values in the classifier defined by the network topology. In batch training, all patterns are presented to the network before learning takes place. Typically, in batch training, several passes are made through the training data. In online training, each pattern is presented once and only once to the net.

[0305] In some embodiments, consideration is given to starting values for weights. If the weights are near zero, then the operative part of the sigmoid commonly used in the hidden layer of a neural network (see, e.g., Hastie et al., 2001, *The Elements of Statistical Learning*, Springer-Verlag, New York, hereby incorporated by reference) is roughly linear, and hence the neural network collapses into an approximately linear classifier. In some embodiments, starting values for weights are chosen to be random values near zero. Hence the classifier starts out nearly linear, and becomes nonlinear as the weights increase. Individual units localize to directions and introduce nonlinearities where needed. Use of exact zero weights leads to zero derivatives and perfect symmetry, and the algorithm never moves. Alternatively, starting with large weights often leads to poor solutions.

[0306] Since the scaling of inputs determines the effective scaling of weights in the bottom layer, it can have a large effect on the quality of the final solution. Thus, in some embodiments, at the outset all expression values are standardized to have mean zero and a standard deviation of one. This ensures all inputs are treated equally in the regularization process, and allows one to choose a meaningful range for the random starting weights. With standardization inputs, it is typical to take random uniform weights over the range $[-0.7, +0.7]$.

[0307] A recurrent problem in the use of three-layer networks is the optimal number of hidden units to use in the network. The number of inputs and outputs of a three-layer network are determined by the problem to be solved. In the present invention, the number of inputs for a given neural network will equal the number of biomarkers selected from the training population. The number of output for the neural network will typically be just one. However, in some embodiments more than one output is used so that more than just two states can be defined by the network. For example, a multi-output neural network can be used to discriminate between, healthy phenotypes, various stages of SIRS, and/or various stages of sepsis. If too many hidden units are used in a neural network, the network will have too many degrees of freedom and is trained too long, there is a danger that the network will overfit the data. If there are too few hidden units, the training set cannot be learned. Generally speaking, however, it is better to have too many hidden units than too few. With too few hidden units, the classifier might not have enough flex-

ibility to capture the nonlinearities in the data; with too many hidden units, the extra weight can be shrunk towards zero if appropriate regularization or pruning, as described below, is used. In typical embodiments, the number of hidden units is somewhere in the range of 5 to 100, with the number increasing with the number of inputs and number of training cases.

[0308] One general approach to determining the number of hidden units to use is to apply a regularization approach. In the regularization approach, a new criterion function is constructed that depends not only on the classical training error, but also on classifier complexity. Specifically, the new criterion function penalizes highly complex classifiers; searching for the minimum in this criterion is to balance error on the training set with error on the training set plus a regularization term, which expresses constraints or desirable properties of solutions:

$$J = J_{\text{pat}} + \lambda J_{\text{reg}}$$

The parameter λ is adjusted to impose the regularization more or less strongly. In other words, larger values for λ will tend to shrink weights towards zero: typically cross-validation with a validation set is used to estimate λ . This validation set can be obtained by setting aside a random subset of the training population. Other forms of penalty have been proposed, for example the weight elimination penalty (see, e.g., Hastie et al., 2001, *The Elements of Statistical Learning*, Springer-Verlag, New York, hereby incorporated by reference).

[0309] Another approach to determine the number of hidden units to use is to eliminate-prune-weights that are least needed. In one approach, the weights with the smallest magnitude are eliminated (set to zero). Such magnitude-based pruning can work, but is nonoptimal; sometimes weights with small magnitudes are important for learning and training data. In some embodiments, rather than using a magnitude-based pruning approach, Wald statistics are computed. The fundamental idea in Wald Statistics is that they can be used to estimate the importance of a hidden unit (weight) in a classifier. Then, hidden units having the least importance are eliminated (by setting their input and output weights to zero). Two algorithms in this regard are the Optimal Brain Damage (OBD) and the Optimal Brain Surgeon (OBS) algorithms that use second-order approximation to predict how the training error depends upon a weight, and eliminate the weight that leads to the smallest increase in training error.

[0310] Optimal Brain Damage and Optimal Brain Surgeon share the same basic approach of training a network to local minimum error at weight w , and then pruning a weight that leads to the smallest increase in the training error. The predicted functional increase in the error for a change in full weight vector δw is:

$$\delta J = \left(\frac{\partial J}{\partial w} \right)^T \cdot \delta w + \frac{1}{2} \delta w^T \cdot \frac{\partial^2 J}{\partial w^2} \cdot \delta w + O(\|\delta w\|^3)$$

where

$$\frac{\partial^2 J}{\partial w^2}$$

is the Hessian matrix. The first term vanishes at a local minimum in error; third and higher order terms are ignored. The

general solution for minimizing this function given the constraint of deleting one weight is:

$$\delta w = -\frac{w_q}{[H^{-1}]_{qq}} H^{-1} \cdot u_q \text{ and } L_q = \frac{1}{2} - \frac{w_q^2}{[H^{-1}]_{qq}}$$

Here, u_q is the unit vector along the qth direction in weight space and L_q is approximation to the saliency of the weight q—the increase in training error if weight q is pruned and the other weights updated δw . These equations require the inverse of H. One method to calculate this inverse matrix is to start with a small value, $H_0^{-1} = \alpha^{-1}I$, where α is a small parameter—effectively a weight constant. Next the matrix is updated with each pattern according to

$$H_{m+1}^{-1} = H_m^{-1} - \frac{H_m^{-1} X_{m+1} X_{m+1}^T H_m^{-1}}{\frac{n}{\alpha_m} + X_{m+1}^T H_m^{-1} X_{m+1}} \tag{Eqn. 1}$$

where the subscripts correspond to the pattern being presented and α_m decreases with m. After the full training set has been presented, the inverse Hessian matrix is given by $H^{-1} = H_n^{-1}$. In algorithmic form, the Optimal Brain Surgeon method is:

```

begin initialize  $n_H, w, \theta$ 
train a reasonably large network to minimum error
do compute  $H^{-1}$  by Eqn. 1

 $q^* \leftarrow \operatorname{argmin}_q w_q^2 / (2[H^{-1}]_{qq})$  (saliency  $L_q$ )

 $w \leftarrow w - \frac{w_{q^*}}{[H^{-1}]_{q^*q^*}} H^{-1} e_{q^*}$  (saliency  $L_{q^*}$ )

until  $J(w) > \theta$ 
return w
end
    
```

[0311] The Optimal Brain Damage method is computationally simpler because the calculation of the inverse Hessian matrix in line 3 is particularly simple for a diagonal matrix. The above algorithm terminates when the error is greater than a criterion initialized to be θ . Another approach is to change line 6 to terminate when the change in $J(w)$ due to elimination of a weight is greater than some criterion value. In some embodiments, the back-propagation neural network See, for example Abdi, 1994, “A neural network primer,” J. Biol System. 2, 247-283, hereby incorporated by reference in its entirety.

5.5.7 Clustering

[0312] In some embodiments, features for select biomarkers of the present invention are used to cluster a training set. For example, consider the case in which ten features (corresponding to ten biomarkers) described in the present invention is used. Each member m of the training population will have feature values (e.g. expression values) for each of the ten biomarkers. Such values from a member m in the training population define the vector:

X_{1m}	X_{2m}	X_{3m}	X_{4m}	X_{5m}	X_{6m}	X_{7m}	X_{8m}	X_{9m}	X_{10m}
----------	----------	----------	----------	----------	----------	----------	----------	----------	-----------

where X_{im} is the expression level of the i^{th} biomarker in organism m. If there are m organisms in the training set, selection of i biomarkers will define m vectors. Note that the methods of the present invention do not require that each the expression value of every single biomarker used in the vectors be represented in every single vector m. In other words, data from a subject in which one of the i^{th} biomarkers is not found can still be used for clustering. In such instances, the missing expression value is assigned either a “zero” or some other normalized value. In some embodiments, prior to clustering, the feature values are normalized to have a mean value of zero and unit variance.

[0313] Those members of the training population that exhibit similar expression patterns across the training group will tend to cluster together. A particular combination of genes of the present invention is considered to be a good classifier in this aspect of the invention when the vectors cluster into the trait groups found in the training population. For instance, if the training population includes class a: subjects that do not develop sepsis, and class b: subjects that develop sepsis, an ideal clustering classifier will cluster the population into two groups, with one cluster group uniquely representing class a and the other cluster group uniquely representing class b.

[0314] Clustering is described on pages 211-256 of Duda and Hart, *Pattern Classification and Scene Analysis*, 1973, John Wiley & Sons, Inc., New York, (hereinafter “Duda 1973”) which is hereby incorporated by reference in its entirety. As described in Section 6.7 of Duda 1973, the clustering problem is described as one of finding natural groupings in a dataset. To identify natural groupings, two issues are addressed. First, a way to measure similarity (or dissimilarity) between two samples is determined. This metric (similarity measure) is used to ensure that the samples in one cluster are more like one another than they are to samples in other clusters. Second, a mechanism for partitioning the data into clusters using the similarity measure is determined.

[0315] Similarity measures are discussed in Section 6.7 of Duda 1973, where it is stated that one way to begin a clustering investigation is to define a distance function and to compute the matrix of distances between all pairs of samples in a dataset. If distance is a good measure of similarity, then the distance between samples in the same cluster will be significantly less than the distance between samples in different clusters. However, as stated on page 215 of Duda 1973, clustering does not require the use of a distance metric. For example, a nonmetric similarity function $s(x, x')$ can be used to compare two vectors x and x'. Conventionally, $s(x, x')$ is a symmetric function whose value is large when x and x' are somehow “similar”. An example of a nonmetric similarity function $s(x, x')$ is provided on page 216 of Duda 1973.

[0316] Once a method for measuring “similarity” or “dissimilarity” between points in a dataset has been selected, clustering requires a criterion function that measures the clustering quality of any partition of the data. Partitions of the data set that extremize the criterion function are used to cluster the data. See page 217 of Duda 1973. Criterion functions are discussed in Section 6.8 of Duda 1973.

[0317] More recently, Duda et al., *Pattern Classification*, 2nd edition, John Wiley & Sons, Inc. New York, has been published. Pages 537-563 describe clustering in detail. More information on clustering techniques can be found in Kaufman and Rousseeuw, 1990, *Finding Groups in Data: An Introduction to Cluster Analysis*, Wiley, New York, N.Y.; Everitt, 1993, *Cluster analysis* (3d ed.), Wiley, New York, N.Y.; and Backer, 1995, *Computer-Assisted Reasoning in Cluster Analysis*, Prentice Hall, Upper Saddle River, N.J. Particular exemplary clustering techniques that can be used in the present invention include, but are not limited to, hierarchical clustering (agglomerative clustering using nearest-neighbor algorithm, farthest-neighbor algorithm, the average linkage algorithm, the centroid algorithm, or the sum-of-squares algorithm), k-means clustering, fuzzy k-means clustering algorithm, and Jarvis-Patrick clustering.

5.5.8 Principle Component Analysis

[0318] Principal component analysis (PCA) has been proposed to analyze gene expression data. More generally, PCA can be used to analyze feature value data of biomarkers of the present invention in order to construct a decision rule that discriminates converters from nonconverters. Principal component analysis is a classical technique to reduce the dimensionality of a data set by transforming the data to a new set of variable (principal components) that summarize the features of the data. See, for example, Jolliffe, 1986, *Principal Component Analysis*, Springer, N.Y., which is hereby incorporated by reference. Principal component analysis is also described in Draghici, 2003, *Data Analysis Tools for DNA Microarrays*, Chapman & Hall/CRC, which is hereby incorporated by reference. What follows is non-limiting examples of principal components analysis.

[0319] Principal components (PCs) are uncorrelated and are ordered such that the k^{th} PC has the k^{th} largest variance among PCs. The k^{th} PC can be interpreted as the direction that maximizes the variation of the projections of the data points such that it is orthogonal to the first $k-1$ PCs. The first few PCs capture most of the variation in the data set. In contrast, the last few PCs are often assumed to capture only the residual 'noise' in the data.

[0320] PCA can also be used to create a classifier in accordance with the present invention. In such an approach, vectors for the select biomarkers of the present invention can be constructed in the same manner described for clustering above. In fact, the set of vectors, where each vector represents the feature values (e.g., abundance values) for the select genes from a particular member of the training population, can be viewed as a matrix. In some embodiments, this matrix is represented in a Free-Wilson method of qualitative binary description of monomers (Kubinyi, 1990, *3D QSAR in drug design theory methods and applications*, Pergamon Press, Oxford, pp 589-638), and distributed in a maximally compressed space using PCA so that the first principal component (PC) captures the largest amount of variance information possible, the second principal component (PC) captures the second largest amount of all variance information, and so forth until all variance information in the matrix has been considered.

[0321] Then, each of the vectors (where each vector represents a member of the training population) is plotted. Many different types of plots are possible. In some embodiments, a one-dimensional plot is made. In this one-dimensional plot, the value for the first principal component from each of the

members of the training population is plotted. In this form of plot, the expectation is that members of a first subgroup (e.g. those subjects that do not develop sepsis in a determined time period) will cluster in one range of first principal component values and members of a second subgroup (e.g., those subjects that develop sepsis in a determined time period) will cluster in a second range of first principal component values.

[0322] In one ideal example, the training population comprises two subgroups: "sepsis" and "SIRS." The first principal component is computed using the molecular marker expression values for the select biomarkers of the present invention across the entire training population data set. Then, each member of the training set is plotted as a function of the value for the first principal component. In this ideal example, those members of the training population in which the first principal component is positive are the "responders" and those members of the training population in which the first principal component is negative are "subjects with sepsis."

[0323] In some embodiments, the members of the training population are plotted against more than one principal component. For example, in some embodiments, the members of the training population are plotted on a two-dimensional plot in which the first dimension is the first principal component and the second dimension is the second principal component. In such a two-dimensional plot, the expectation is that members of each subgroup represented in the training population will cluster into discrete groups. For example, a first cluster of members in the two-dimensional plot will represent subjects that develop sepsis in a given time period and a second cluster of members in the two-dimensional plot will represent subjects that do not develop sepsis in a given time period.

5.5.9 Nearest Neighbor Analysis

[0324] Nearest neighbor classifiers are memory-based and require no classifier to be fit. Given a query point x_0 , the k training points $x_{(r)}$, r , k closest in distance to x_0 are identified and then the point x_0 is classified using the k nearest neighbors. Ties can be broken at random. In some embodiments, Euclidean distance in feature space is used to determine distance as:

$$d_{(i)} = \|x_{(i)} - x_0\|.$$

Typically, when the nearest neighbor algorithm is used, the expression data used to compute the linear discriminant is standardized to have mean zero and variance 1. In the present invention, the members of the training population are randomly divided into a training set and a test set. For example, in one embodiment, two thirds of the members of the training population are placed in the training set and one third of the members of the training population are placed in the test set. A select combination of biomarkers of the present invention represents the feature space into which members of the test set are plotted. Next, the ability of the training set to correctly characterize the members of the test set is computed. In some embodiments, nearest neighbor computation is performed several times for a given combination of biomarkers of the present invention. In each iteration of the computation, the members of the training population are randomly assigned to the training set and the test set. Then, the quality of the combination of biomarkers is taken as the average of each such iteration of the nearest neighbor computation.

[0325] The nearest neighbor rule can be refined to deal with issues of unequal class priors, differential misclassification costs, and feature selection. Many of these refinements

involve some form of weighted voting for the neighbors. For more information on nearest neighbor analysis, see Duda, *Pattern Classification*, Second Edition, 2001, John Wiley & Sons, Inc; and Hastie, 2001, *The Elements of Statistical Learning*, Springer, N.Y., each of which is hereby incorporated by reference in its entirety.

5.5.10 Linear Discriminant Analysis

[0326] Linear discriminant analysis (LDA) attempts to classify a subject into one of two categories based on certain object properties. In other words, LDA tests whether object attributes measured in an experiment predict categorization of the objects. LDA typically requires continuous independent variables and a dichotomous categorical dependent variable. In the present invention, the feature values for the select combinations of biomarkers of the present invention across a subset of the training population serve as the requisite continuous independent variables. The trait subgroup classification of each of the members of the training population serves as the dichotomous categorical dependent variable.

[0327] LDA seeks the linear combination of variables that maximizes the ratio of between-group variance and within-group variance by using the grouping information. Implicitly, the linear weights used by LDA depend on how the feature values of a molecular marker across the training set separates in the two groups (e.g., a group a that develops sepsis during a defined time period and a group b that does not develop sepsis during a defined time period) and how these feature values correlate with the feature values of other biomarkers. In some embodiments, LDA is applied to the data matrix of the N members in the training sample by K biomarkers in a combination of biomarkers described in the present invention. Then, the linear discriminant of each member of the training population is plotted. Ideally, those members of the training population representing a first subgroup (e.g. those subjects that develop sepsis in a defined time period) will cluster into one range of linear discriminant values (e.g., negative) and those member of the training population representing a second subgroup (e.g. those subjects that will not develop sepsis in a defined time period) will cluster into a second range of linear discriminant values (e.g., positive). The LDA is considered more successful when the separation between the clusters of discriminant values is larger. For more information on linear discriminant analysis, see Duda, *Pattern Classification*, Second Edition, 2001, John Wiley & Sons, Inc; and Hastie, 2001, *The Elements of Statistical Learning*, Springer, N.Y.; and Venables & Ripley, 1997, *Modern Applied Statistics with s-plus*, Springer, N.Y., each of which is hereby incorporated by reference in its entirety.

5.5.11 Quadratic Discriminant Analysis

[0328] Quadratic discriminant analysis (QDA) takes the same input parameters and returns the same results as LDA. QDA uses quadratic equations, rather than linear equations, to produce results. LDA and QDA are interchangeable, and which to use is a matter of preference and/or availability of software to support the analysis. Logistic regression takes the same input parameters and returns the same results as LDA and QDA.

5.5.12 Support Vector Machines

[0329] In some embodiments of the present invention, support vector machines (SVMs) are used to classify subjects

using feature values of the genes described in the present invention. SVMs are a relatively new type of learning algorithm. See, for example, Cristianini and Shawe-Taylor, 2000, *An Introduction to Support Vector Machines*, Cambridge University Press, Cambridge; Boser et al., 1992, "A training algorithm for optimal margin classifiers," in *Proceedings of the 5th Annual ACM Workshop on Computational Learning Theory*, ACM Press, Pittsburgh, Pa., pp. 142-152; Vapnik, 1998, *Statistical Learning Theory*, Wiley, New York; Mount, 2001, *Bioinformatics: sequence and genome analysis*, Cold Spring Harbor Laboratory Press, Cold Spring Harbor, N.Y., Duda, *Pattern Classification*, Second Edition, 2001, John Wiley & Sons, Inc.; and Hastie, 2001, *The Elements of Statistical Learning*, Springer, N.Y.; and Furey et al., 2000, *Bioinformatics* 16, 906-914, each of which is hereby incorporated by reference in its entirety. When used for classification, SVMs separate a given set of binary labeled data training data with a hyper-plane that is maximally distance from them. For cases in which no linear separation is possible, SVMs can work in combination with the technique of 'kernels', which automatically realizes a non-linear mapping to a feature space. The hyper-plane found by the SVM in feature space corresponds to a non-linear decision boundary in the input space.

[0330] In one approach, when a SVM is used, the feature data is standardized to have mean zero and unit variance and the members of a training population are randomly divided into a training set and a test set. For example, in one embodiment, two thirds of the members of the training population are placed in the training set and one third of the members of the training population are placed in the test set. The expression values for a combination of genes described in the present invention is used to train the SVM. Then the ability for the trained SVM to correctly classify members in the test set is determined. In some embodiments, this computation is performed several times for a given combination of molecular markers. In each iteration of the computation, the members of the training population are randomly assigned to the training set and the test set. Then, the quality of the combination of biomarkers is taken as the average of each such iteration of the SVM computation.

5.5.13 Evolutionary Methods

[0331] Inspired by the process of biological evolution, evolutionary methods of decision rule design employ a stochastic search for an decision rule. In broad overview, such methods create several decision rules—a population—from a combination of biomarkers described in the present invention. Each decision rule varies somewhat from the other. Next, the decision rules are scored on feature data across the training population. In keeping with the analogy with biological evolution, the resulting (scalar) score is sometimes called the fitness. The decision rules are ranked according to their score and the best decision rules are retained (some portion of the total population of decision rules). Again, in keeping with biological terminology, this is called survival of the fittest. The decision rules are stochastically altered in the next generation—the children or offspring. Some offspring decision rules will have higher scores than their parent in the previous generation, some will have lower scores. The overall process is then repeated for the subsequent generation: the decision rules are scored and the best ones are retained, randomly altered to give yet another generation, and so on. In part, because of the ranking, each generation has, on average, a

slightly higher score than the previous one. The process is halted when the single best decision rule in a generation has a score that exceeds a desired criterion value. More information on evolutionary methods is found in, for example, Duda, *Pattern Classification*, Second Edition, 2001, John Wiley & Sons, Inc.

5.5.14 Other Data Analysis Algorithms

[0332] The data analysis algorithms described above are merely examples of the types of methods that can be used to construct a decision rule for discriminating converters from nonconverters. Moreover, combinations of the techniques described above can be used. Some combinations, such as the use of the combination of decision trees and boosting, have been described. However, many other combinations are possible. In addition, in other techniques in the art such as Projection Pursuit and Weighted Voting can be used to construct decision rules.

5.6 BIOMARKERS

[0333] In specific embodiments, the present invention provides biomarkers that are useful in diagnosing or predicting sepsis and/or its stages of progression in a subject. While the methods of the present invention may use an unbiased approach to identifying predictive biomarkers, it will be clear to the artisan that specific groups of biomarkers associated with physiological responses or with various signaling pathways may be the subject of particular attention. This is particularly the case where biomarkers from a biological sample are contacted with an array that can be used to measure the amount of various biomarkers through direct and specific interaction with the biomarkers (e.g., an antibody array or a nucleic acid array). In this case, the choice of the components of the array may be based on a suggestion that a particular pathway is relevant to the determination of the status of sepsis or SIRS in a subject. The indication that a particular biomarker has a feature that is predictive or diagnostic of sepsis or SIRS may give rise to an expectation that other biomarkers that are physiologically regulated in a concerted fashion likewise may provide a predictive or diagnostic feature. The artisan will appreciate, however, that such an expectation may not be realized because of the complexity of biological systems. For example, if the amount of a specific mRNA biomarker were a predictive feature, a concerted change in mRNA expression of another biomarker might not be measurable, if the expression of the other biomarker was regulated at a post-translational level. Further, the mRNA expression level of a biomarker may be affected by multiple converging pathways that may or may not be involved in a physiological response to sepsis.

[0334] Biomarkers can be obtained from any biological sample, which can be, by way of example and not of limitation, whole blood, plasma, saliva, serum, red blood cells, platelets, neutrophils, eosinophils, basophils, lymphocytes, monocytes, urine, cerebral spinal fluid, sputum, stool, cells and cellular extracts, or other biological fluid sample, tissue sample or tissue biopsy from a host or subject. The precise biological sample that is taken from the subject may vary, but the sampling preferably is minimally invasive and is easily performed by conventional techniques.

[0335] Measurement of a phenotypic change may be carried out by any conventional technique. Measurement of body temperature, respiration rate, pulse, blood pressure, or other

physiological parameters can be achieved via clinical observation and measurement. Measurements of biomarker molecules may include, for example, measurements that indicate the presence, concentration, expression level, or any other value associated with a biomarker molecule. The form of detection of biomarker molecules typically depends on the method used to form a profile of these biomarkers from a biological sample. See Section 5.4, above, and Tables 30, I, J, K, L, and M below.

[0336] In a particular embodiment, the biomarker profile comprises at least two different biomarkers listed in column four or five of Table 30. The biomarker profile further comprises a respective corresponding feature for the at least two biomarkers. Such biomarkers can be, for example, mRNA transcripts, cDNA or some other nucleic acid, for example amplified nucleic acid, or proteins. Generally, the at least two biomarkers are derived from at least two different genes. In the case where a biomarker in the at least two different biomarkers is listed in column four of Table 30, the biomarker can be, for example, a transcript made by the listed gene, a complement thereof, or a discriminating fragment or complement thereof, or a cDNA thereof, or a discriminating fragment of the cDNA, or a discriminating amplified nucleic acid molecule corresponding to all or a portion of the transcript or its complement, or a protein encoded by the gene, or a discriminating fragment of the protein, or an indication of any of the above. Further still, the biomarker can be, for example, a protein listed in column five of Table 30, or a discriminating fragment of the protein, or an indication of any of the above. Here, a discriminating molecule or fragment is a molecule or fragment that, when detected, indicates presence or abundance of the above-identified transcript, cDNA, amplified nucleic acid, or protein. In accordance with this embodiment, the biomarker profiles of the present invention can be obtained using any standard assay known to those skilled in the art, or in an assay described herein, to detect a biomarker. Such assays are capable, for example, of detecting the products of expression (e.g., nucleic acids and/or proteins) of a particular gene or allele of a gene of interest (e.g., a gene disclosed in Table 30). In one embodiment, such an assay utilizes a nucleic acid microarray.

[0337] In a particular embodiment, the biomarker profile comprises at least two different biomarkers that each contain one of the probesets listed in column 2 of Table 30, biomarkers that contain the complement of one of the probesets of Table 30, or biomarkers that contain an amino acid sequence encoded by a gene that either contains one of the probesets of Table 30 or the complement of one of the probesets of Table 30. Such biomarkers can be, for example, mRNA transcripts, cDNA or some other nucleic acid, for example amplified nucleic acid, or proteins. The biomarker profile further comprises a respective corresponding feature for the at least two biomarkers. Generally, the at least two biomarkers are derived from at least two different genes. In the case where a biomarker is based upon a gene that includes the sequence of a probeset listed in Table 30, the biomarker can be, for example, a transcript made by the gene, a complement thereof, or a discriminating fragment or complement thereof, or a cDNA thereof, or a discriminating fragment of the cDNA, or a discriminating amplified nucleic acid molecule corresponding to all or a portion of the transcript or its complement, or a protein encoded by the gene, or a discriminating fragment of the protein, or an indication of any of the above. Further still, the biomarker can be, for example, a protein encoded by a

gene that includes a probeset sequence described in Table 30, or a discriminating fragment of the protein, or an indication of any of the above. Here, a discriminating molecule or fragment is a molecule or fragment that, when detected, indicates presence or abundance of the above-identified transcript, cDNA, amplified nucleic acid, or protein.

[0338] In some embodiments the biomarker profile has between 2 and 626 biomarkers listed in Table 30. In some embodiments, the biomarker profile has between 3 and 50 biomarkers listed in Table 30. In some embodiments, the biomarker profile has between 4 and 25 biomarkers listed in Table 30. In some embodiments, the biomarker profile has at least 3 biomarkers listed in Table 30. In some embodiments, the biomarker profile has at least 4 biomarkers listed in Table 30. In some embodiments, the biomarker profile has at least 2, 3, 4, 5, 6, 7, 8, 9, 10, 11, 12, 13, 14, 15, 16, 17, 18, 19, 20, 25, 30, 35, 40, 45, 50, 55, 60, 65, 70, 75, 80, 85, 90, 95, 96, or 100 biomarkers listed in Table 30. In some embodiments, each such biomarker is a nucleic acid. In some embodiments, each such biomarker is a protein.

[0339] In some embodiments, some of the biomarkers in the biomarker profile are nucleic acids and some of the biomarkers in the biomarker profile are proteins. In some embodiments the biomarker profile has between 2 and 130 biomarkers listed in Table 31. In some embodiments, the biomarker profile has between 3 and 50 biomarkers listed in Table 31. In some embodiments, the biomarker profile has between 4 and 25 biomarkers listed in Table 31. In some embodiments, the biomarker profile has at least 3 biomarkers listed in Table 31. In some embodiments, the biomarker profile has at least 4 biomarkers listed in Table 30. In some embodiments, the biomarker profile has at least 6, 10, 15, 20, 25, 30, 35, 40, 45, 50, 55, 60, 65, 70, 75, 80, 85, 90, 95, 96, or 100 biomarkers listed in Table 31.

[0340] In some embodiments the biomarker profile has between 2 and 10 biomarkers listed in Table 33. In some embodiments, the biomarker profile has between 3 and 10 biomarkers listed in Table 32. In some embodiments, the biomarker profile has between 4 and 10 biomarkers listed in Table 32. In some embodiments, the biomarker profile has at least 3 biomarkers listed in Table 32. In some embodiments, the biomarker profile has at least 4 biomarkers listed in Table 32. In some embodiments, the biomarker profile has at least 6, 7, 8, 9, or 10 biomarkers listed in Table 32. In some embodiments, each such biomarker is a nucleic acid. In some embodiments, each such biomarker is a protein. In some embodiments, some of the biomarkers in the biomarker profile are nucleic acids and some of the biomarkers in the biomarker profile are proteins.

[0341] In some embodiments the biomarker profile has between 2 and 10 biomarkers listed in Table 33. In some embodiments, the biomarker profile has between 3 and 10 biomarkers listed in Table 33. In some embodiments, the biomarker profile has between 4 and 10 biomarkers listed in Table 33. In some embodiments, the biomarker profile has at least 3 biomarkers listed in Table 33. In some embodiments, the biomarker profile has at least 4 biomarkers listed in Table 33. In some embodiments, the biomarker profile has at least 6, 7, 8, 9, or 10 biomarkers listed in Table 33. In some embodiments, each such biomarker is a nucleic acid. In some embodiments, each such biomarker is a protein. In some embodiments, some of the biomarkers in the biomarker profile are nucleic acids and some of the biomarkers in the biomarker profile are proteins.

[0342] In some embodiments the biomarker profile has between 2 and 130 biomarkers listed in Table 34. In some embodiments, the biomarker profile has between 3 and 40 biomarkers listed in Table 34. In some embodiments, the biomarker profile has between 4 and 25 biomarkers listed in Table 34. In some embodiments, the biomarker profile has at least 3, 4, 5, 6, 7, 8, 9, 10, 11, 12, 13, 14, 15, 16, 17, 18, 19, 20, 25, 30, 35, or 40 biomarkers listed in Table 34. In some embodiments, each such biomarker is a nucleic acid. In some embodiments, each such biomarker is a protein. In some embodiments, some of the biomarkers in the biomarker profile are nucleic acids and some of the biomarkers in the biomarker profile are proteins.

[0343] In some embodiments the biomarker profile has between 2 and 7 biomarkers listed in Table 36. In some embodiments, the biomarker profile has between 3 and 6 biomarkers listed in Table 36. In some embodiments, the biomarker profile has between 4 and 7 biomarkers listed in Table 36. In some embodiments, the biomarker profile has at least 3 biomarkers listed in Table 36. In some embodiments, the biomarker profile has at least 4 biomarkers listed in Table 36. In some embodiments, the biomarker profile has at least 6, 7, 8, 9, or 10 biomarkers listed in Table 36. In some embodiments, each such biomarker is a nucleic acid. In some embodiments, each such biomarker is a protein. In some embodiments, some of the biomarkers in the biomarker profile are nucleic acids and some of the biomarkers in the biomarker profile are proteins.

[0344] In some embodiments the biomarker profile has between 2 and 53 biomarkers listed in Table I. In some embodiments, the biomarker profile has between 3 and 50 biomarkers listed in Table I. In some embodiments, the biomarker profile has between 4 and 25 biomarkers listed in Table I. In some embodiments, the biomarker profile has at least 3 biomarkers listed in Table I. In some embodiments, the biomarker profile has at least 4 biomarkers listed in Table I. In some embodiments, the biomarker profile has at least 5, 6, 7, 8, 9, 10, 11, 12, 13, 14, 15, 15, 17, 18, 19, 20, 21, 22, 23, 24, 25, 26, 27, 28, 29, 30, 31, 32, 33, 34, 35, 36, 37, 38, 39, 40, 41, 42, 43, 44, 45, 46, 47, 48, 49, 50, 51, 52, or 53 biomarkers listed in Table I. In some embodiments, each of the biomarkers in the biomarker profile is a nucleic acid in Table I. In some embodiments, each of the biomarkers in the biomarker profile is a protein in Table I. In some embodiments, some of the biomarkers in a biomarker profile are proteins in Table I and some of the biomarkers in the same biomarker profile are nucleic acids in Table I.

[0345] In some embodiments the biomarker profile has between 2 and 44 biomarkers listed in Table J. In some embodiments, the biomarker profile has between 3 and 44 biomarkers listed in Table J. In some embodiments, the biomarker profile has between 4 and 25 biomarkers listed in Table J. In some embodiments, the biomarker profile has at least 3 biomarkers listed in Table J. In some embodiments, the biomarker profile has at least 4 biomarkers listed in Table J. In some embodiments, the biomarker profile has at least 5, 6, 7, 8, 9, 10, 11, 12, 13, 14, 15, 15, 17, 18, 19, 20, 21, 22, 23, 24, 25, 26, 27, 28, 29, 30, 31, 32, 33, 34, 35, 36, 37, 38, 39, 40, 41, 42, or 43 biomarkers listed in Table J. In some embodiments, each of the biomarkers in the biomarker profile is a nucleic acid in Table J. In some embodiments, each of the biomarkers in the biomarker profile is a protein in Table J. In some embodiments, some of the biomarkers in a biomarker profile

are proteins in Table J and some of the biomarkers in the same biomarker profile are nucleic acids in Table J.

[0346] In some embodiments the biomarker profile has between 2 and 10 biomarkers listed in Table K. In some embodiments, the biomarker profile has between 3 and 10 biomarkers listed in Table K. In some embodiments, the biomarker profile has between 4 and 10 biomarkers listed in Table K. In some embodiments, the biomarker profile has at least 3 biomarkers listed in Table K. In some embodiments, the biomarker profile has at least 4 biomarkers listed in Table K. In some embodiments, the biomarker profile has at least 5, 6, 7, 8, or 9 biomarkers listed in Table K. In some embodiments, each of the biomarkers in the biomarker profile is a nucleic acid in Table K. In some embodiments, each of the biomarkers in the biomarker profile is a protein in Table K. In some embodiments, some of the biomarkers in a biomarker profile are proteins in Table K and some of the biomarkers in the same biomarker profile are nucleic acids in Table K.

5.6.1 Isolation of Useful Biomarkers

[0347] The biomarkers of the present invention may, for example, be used to raise antibodies that bind the biomarker if it is a protein (using methods described in Section 5.4.2, supra, or any method well known to those of skill in the art), or they may be used to develop a specific oligonucleotide probe, if it is a nucleic acid, for example, using a method described in Section 5.4.1, supra, or any method well known to those of skill in the art. The skilled artisan will readily appreciate that useful features can be further characterized to determine the molecular structure of the biomarker. Methods for characterizing biomarkers in this fashion are well-known in the art and include X-ray crystallography, high-resolution mass spectrometry, infrared spectrometry, ultraviolet spectrometry and nuclear magnetic resonance. Methods for determining the nucleotide sequence of nucleic acid biomarkers, the amino acid sequence of polypeptide biomarkers, and the composition and sequence of carbohydrate biomarkers also are well-known in the art.

5.7 APPLICATION OF THE PRESENT INVENTION TO SIRS SUBJECTS

[0348] In one embodiment, the presently described methods are used to screen SIRS subjects who are at risk for developing sepsis. A biological sample is taken from a SIRS-positive subject and used to construct a biomarker profile. The biomarker profile is then evaluated to determine whether the feature values of the biomarker profile satisfy a first value set associated with a particular decision rule. This evaluation classifies the subject as a converter or a nonconverter. A treatment regimen may then be initiated to forestall or prevent the progression of sepsis when the subject is classified as a converter.

5.8 APPLICATION OF THE PRESENT INVENTION TO STAGES OF SEPSIS

[0349] In one embodiment, the presently described methods are used to screen subjects who are particularly at risk for developing a certain stage of sepsis. A biological sample is taken from a subject and used to construct a biomarker profile. The biomarker profile is then evaluated to determine whether the feature values of the biomarker profile satisfy a first value set associated with a particular decision rule. This evaluation classifies the subject as having or not having a particular stage

of sepsis. A treatment regimen may then be initiated to treat the specific stage of sepsis. In some embodiments, the stage of sepsis is for example, onset of sepsis, severe sepsis, septic shock, or multiple organ dysfunction.

5.9 EXEMPLARY EMBODIMENTS

[0350] In some embodiments of the present invention, a biomarker profile is obtained using a biological sample from a test subject, particularly a subject at risk of developing sepsis, having sepsis, or suspected of having sepsis. The biomarker profile in such embodiments is evaluated. This evaluation can be made, for example, by applying a decision rule to the test subject. The decision rule can, for example, be or have been constructed based upon the biomarker profiles obtained from subjects in the training population. The training population, in one embodiment, includes (a) subjects that had SIRS and were then diagnosed as septic during an observation time period as well as (b) subjects that had SIRS and were not diagnosed as septic during an observation time period. If the biomarker profile from the test subject contains appropriately characteristic features, then the test subject is diagnosed as having a more likely chance of becoming septic, as being afflicted with sepsis or as being at the particular stage in the progression of sepsis. Various populations of subjects including those who are suffering from SIRS (e.g., SIRS-positive subjects) or those who are suffering from an infection but who are not suffering from SIRS (e.g., SIRS-negative subjects) can serve as training populations. Accordingly, the present invention allows the clinician to distinguish, inter alia, between those subjects who do not have SIRS, those who have SIRS but are not likely to develop sepsis within a given time frame, those who have SIRS and who are at risk of eventually becoming septic, and those who are suffering from a particular stage in the progression of sepsis. For more details on suitable training populations and suitable data collected from such populations, see Section 5.5, above.

5.10 USE OF ANNOTATION DATA TO IDENTIFY DISCRIMINATING BIOMARKERS

[0351] In some embodiments, data analysis algorithms identify a large set of biomarkers whose features discriminate between converters and nonconverters. For example, in some embodiments, application of a data analysis algorithm to a training population results in the selection of more than 500 biomarkers, more than 1000 biomarkers, or more than 10,000 biomarkers. In some embodiments, further reduction in the number of biomarkers that are deemed to be discriminating is desired. Accordingly, in some embodiments, filtering rules that are complementary to data analysis algorithms (e.g., the data analysis algorithms of Section 5.5) are used to further reduce the list of discriminating biomarkers identified by the data analysis algorithms. Specifically, the list of biomarkers identified by application of one or more data analysis algorithms to the biomarker profile data measured in a training population is further refined by application of annotation data based filtering rules to the list. In such embodiments, those biomarkers in the set of biomarkers identified by the one or more data analysis algorithms that satisfy the one or more applied annotation data based filtering rules remain in the set of discriminating biomarkers. In some instances, those biomarkers in the set of biomarkers identified by the one or more data analysis algorithms that do not satisfy the one or more applied annotation data based filtering rules are removed

from the set. In other instances, those biomarkers in the set of biomarkers identified by the one or more data analysis algorithms that do not satisfy the one or more applied annotation data based filtering rules stay in the set and those that satisfy the one or more applied annotation data based filtering rules are removed from the set. In this way, annotation data can be used to reduce the number of biomarkers in the set of discriminating biomarkers identified by the data analysis algorithms.

[0352] Annotation data based filtering rules are rules based upon annotation data. Annotation data refers to any type of data that describes a property of a biomarker. An example of annotation data is the identification of biological pathways to which a given biomarker belongs. Another example of annotation data is enzymatic class (e.g., phosphodiesterases, kinases, metalloproteinases, etc.). Still other examples of annotation data include, but are not limited to, protein domain information, enzymatic substrate information, enzymatic reaction information, and protein interaction data. Yet another example of annotation data is disease association, in other words, which disease process a given biomarker has been linked to or otherwise affects. Another form of annotation data is any type of data that associates biomarker expression, other forms of biomarker abundance, and/or biomarker activity, with cellular localization, tissue type localization, and/or cell type localization.

[0353] As the name implies, annotation data is used to construct an annotation data based filtering rule. An example of an annotation data based filtering rule is:

Annotation rule 1:
remove all transcription factors from the training set.

Application of this filtering rule to a set of biomarkers will remove all transcription factors from the set.

[0354] Another type of annotation data based filtering rule is:

Annotation rule 2:
keep all biomarkers that are enriched for annotation X in a biomarker list.

Application of this filtering rule will only keep those biomarkers in a given list that are enriched (overrepresented) for annotation X in the list. To more fully appreciate this filtering rule, consider an exemplary biomarker set that has been identified by application of a data analysis algorithm (Section 5.5) to biomarker profiles measured using training population data measured in accordance with a technique disclosed in Section 5.4. This exemplary biomarker set has 500 biomarkers. Assume, for in this illustrative example, that the full set of biomarkers in a human consists of 25,000 biomarkers. Here, the 25,000 biomarkers is a population and the 500 biomarker set is the sample. As used here, the term “population” consists of all possible observable biomarkers. The term “sample” is the data that is actually considered. Now, for this example, let X=kinases. Suppose there are 800 known human kinases and further suppose that the set of 500 biomarkers was randomly selected with respect to kinases. Under these circumstances, the list of 500 biomarkers identified by the data analysis algorithms should select about $(500/25,000)*800=16$

kinases. Since there are, in fact, 50 kinases in the sample, a conclusion can be reached that kinases are indeed enriched in the sample relative to the population.

[0355] More formally, in this example, a determination can be made as to whether kinases are enriched in the set of biomarkers identified by the data analysis algorithm (the sample) relative to the population by analysis of the two-way contingency table that describes the observed sample and population:

Group	Kinase		Total
	Yes	No	
Population	800	24,200	25,000
Sample	50	450	500

[0356] Following Agresti, 1996, *An Introduction to Categorical Data Analysis*, John Wiley & Sons, New York, which is hereby incorporated by reference in its entirety, this two-way contingency table can be analyzed by treating each row as an independent binomial variable. In such instances, the true difference in proportions, termed it, $\pi_1 - \pi_2$, compares the probabilities in the two rows. This difference falls between -1 and +1. It equals zero when $\pi_1 = \pi_2$; that is, when the selection of kinases in the sample from the population is independent of the kinase annotation. Of the $N_1=25,000$ biomarkers in the population, 800 are kinases, a proportion of $p_1=800/25,000=0.032$. Of the $N_2=500$ biomarkers in the sample identified using a data analysis algorithm, 50 are kinases, a proportion p_2 of $50/500=0.10$. The sample difference of proportions is $0.032-0.10=-0.068$. In accordance with Agresti, when the counts in the two rows are independent binomial samples, the estimated standard error of $p_1 - p_2$ is:

$$\hat{\sigma}(p_1 - p_2) = \sqrt{\frac{p_1(1 - p_1)}{N_1} + \frac{p_2(1 - p_2)}{N_2}}$$

where N_1 and N_2 are the samples sizes for the population and the sample selected by data analysis algorithm, respectively. The standard error decreases, and hence the estimate of $\pi_1 - \pi_2$ improves, as the sample sizes increase. A large-sample $(100(1-\alpha))\%$ confidence interval for $\pi_1 - \pi_2$ is

$$(p_1 + p_2) \pm z_{\alpha/2} = z_{0.025} = 1.96$$

Thus, for this example, the estimated error is

$$\sqrt{\frac{0.032(1 - 0.032)}{25,000} + \frac{0.10(1 - 0.10)}{500}} = 0.013$$

and a 95% confidence interval for the true difference $\pi_1 - \pi_2$ is $-0.068 \pm 1.96(0.013)$, or -0.068 ± 0.025 . Since the 95% confidence interval contains only negative values, the conclusion can be reached that kinases are enriched in the sample (the biomarker set produced by the data analysis algorithm) relative to the population of 25,000 biomarkers.

[0357] The two-way contingency table in the example above can be analysed using methods known in the art other than the one disclosed above. For example, the chi-square test

for independence and/or Fisher's exact test can be used to test the null hypothesis that the row and column classification variables of the two-way contingency table are independent. **[0358]** The term "X" in annotation rule 2 can be any form of annotation data. In one embodiment, "X" is any biological pathway. As such the annotation data based filtering rule has the following form.

Annotation rule 3:
Select all biomarkers that are in any biological pathway that is enriched in the biomarker list.

To determine whether a particular biological pathway is enriched, the number of biomarkers in a particular biological pathway in the sample is compared with the number of biomarkers that are in the particular biological pathway in the population using, for example, the two-way contingency table analysis described above, or other techniques known in the art. If the biological pathway is enriched in the sample, then all biomarkers in the sample that are also in the biological pathway are retained for further analysis, in accordance with the annotation data based filtering rule.

[0359] An example of enrichment, in which it was shown that the proportion of kinases in the sample was greater than the proportion of kinases in the population across its entire 95% confidence interval has been given. In one embodiment, biomarkers having a given annotation are considered enriched in the sample relative to the population when the proportion of biomarkers having the annotation in the sample is greater than the proportion of biomarkers having the annotation in the population across its entire 95% degree confidence interval as determined by two-way contingency table analysis. In another embodiment, biomarkers having a given annotation are considered enriched in the sample relative to the population if a p value as determined by the Fisher exact test, Chi-square test, or relative algorithms is 0.05 or less, 0.005 or less or 0.0005 or less.

[0360] Another form of annotation data based filtering rule has the following form:

Annotation rule 4:
Select all biomarkers that are in biological pathway X.

[0361] In an embodiment, a set of biomarkers is determined using a data analysis algorithm. Exemplary data analysis algorithms are disclosed in Section 5.5. In addition, Section 6 describes certain tests that can also serve as data analysis algorithms. These tests include, but are not limited to a Wilcoxon test and the like with a statistically significant p value (e.g., 0.05 or less, 0.04, or less, etc.), and/or a requirement that a biomarker exhibit a mean differential abundance between biological samples obtained from converters and biological samples obtained from nonconverters in a training population. Upon application of the data analysis algorithm, a set of biomarkers that discriminates between converters and nonconverters is determined. Next, an annotation rule, for example annotation rule 4, is applied to the set of discriminating biomarkers in order to further reduce the set of biomarkers. Those of skill in the art will appreciate that the order in which these rules are applied is generally not important. For example, annotation rule 4 can be applied first and then cer-

tain data analysis algorithms can be applied, or vice versa. In some embodiments, biomarkers ultimately deemed as discriminating between converters and nonconverters satisfy each of the following criteria: (i) a p value of 0.05 or less ($p < 0.05$) as determined from a Wilcoxon adjusted test using static (single time point) data; (ii) a mean-fold change of 1.2 or greater between converters and nonconverters across the training set using static (single time point data), and (iii) present in a specific biological pathway. See also, Section 6.7, *infra*, for a detailed example. In this example, there is no requirement that members of the pathway are enriched in the set of biomarkers identified by the data analysis algorithms. Furthermore, it is noted that criteria (i) and (ii) are forms of data analysis algorithms and criterion (iii) is a annotation data based filtering rule.

[0362] In another embodiment, once a list of discriminating biomarkers is identified, the biomarkers can then be used to determine the identity of the particular biological pathways from which the discriminating biomarkers are implicated. In certain embodiments, annotation data-based filtering rules are applied to the list of discriminating biomarkers identified by the methods of the present invention (e.g., the methods described in Sections 5.4, 5.5 and 6). Such annotation data-based filtering rules identify the particular biological pathway or pathways that are enriched in the discriminating list of biomarkers identified by the data analysis algorithms. In an exemplary embodiment of the invention, DAVID 2.0 software, available at apps1.niaid.nih.gov/david/, is used to identify and apply such annotation data-based filtering rules to the set of biomarkers identified by the data analysis algorithms in order to identify pathways that are enriched in the set. In some embodiments, those biomarkers that are in an enriched biological pathway are selected for use as discriminating biomarkers in the kits of the present invention.

[0363] In some embodiments of the present invention, biomarkers that are in biological pathways that are enriched in the biomarker set determined by application of a data analysis algorithm to a training population that includes converters and nonconverters can be used as filtering step to reduce the number of biomarkers in the set. In one such approach, biological samples from subjects in a training population are obtained using, e.g., any of one or more of the methods described in Section 5.4, *supra*, and in Section 6, *infra*. In accordance with this embodiment, a nucleic acid array, such as a cDNA microarray, may be employed to generate features of biomarkers in a biomarker profile by detecting the expression of any one or more of the genes known to be or suspected to be involved in the selected biological pathways. Data derived from the cDNA microarray analysis may then be analyzed using any one or more of the analysis algorithms described in Section 5.5, *supra*, to identify biomarkers whose features discriminate between converters and nonconverters. Biomarkers whose corresponding feature values are capable of discriminating, for example, between converters (i.e., SIRS patients who subsequently develop sepsis) and non-converters (i.e., SIRS patients who do not subsequently develop sepsis) can thus be identified and classified as discriminating biomarkers. Biomarkers that are in enriched biological pathways can be selected from this set by applying Annotation rule 3, from above. Representative biological pathways that could be found include, for example, genes involved in the Th1/Th2 cell differentiation pathway). In one embodiment, biomarkers ultimately deemed as discriminating between converters and nonconverters satisfy each of the

following criteria: (i) a p value of 0.05 or less ($p < 0.05$) as determined from a Wilcoxon adjusted test; (ii) a mean-fold change of 1.2 or greater between converters and nonconverters across the training set, and (iii) present in a biological pathway that is enriched in the set of biomarkers derived by application of criteria (i) and (ii).

[0364] In some embodiments of the present invention, annotation data based filtering rules are used to identify biological pathways that are enriched in a given biomarker set. This biomarker set can be, for example, a set of biomarkers that is identified by application of a data analysis algorithm to training data comprising converters and nonconverters. Then, biomarkers in these enriched biological pathways are analyzed using any of the data analysis algorithms disclosed herein in order to identify biomarkers that discriminate between converters and nonconverters. In some instances, some of the biomarkers analyzed in the enriched biological pathways were not among the biomarkers in the original given biomarker set. In some instances, some of the biomarkers in the enriched biological pathways are among the biomarkers in the original given biomarker set. In some embodiments, a secondary assay is used to collect feature data for biomarkers that are in enriched pathways and it is this data that is used to determine whether the biomarkers in the enriched biological pathways discriminate between converters and nonconverters.

[0365] In some embodiments, biomarkers in biological pathways of interest are identified. In one example, genes involved in the Th1/Th2 cell differentiation pathway are identified. Then, these biomarkers are evaluated using the data analysis algorithms disclosed herein to determine whether they discriminate between converters and nonconverters.

5.11 REPRESENTATIVE EMBODIMENT IN ACCORDANCE WITH THE PRESENT INVENTION

[0366] Sections 6.11 through 6.13 identify a number of biomarkers that are of interest in one embodiment in accordance with the present invention. Specifically, one embodiment of the present invention comprises the 10 biomarkers identified in Table 48 of Section 6.11.1, the 34 biomarkers listed in Table 59 of Section 6.11.2, and the 10 biomarkers listed in Table 93 of Section 6.13.1, below. Table 48 and Table 93 each identify MMP9 as a discriminating biomarker. Thus, the total number of biomarkers in Table I is one less than the sum of the biomarkers identified in Tables 48, Table 59, and Table 93, $(34+10+10-1)$ or 53. These biomarkers are reproduced in Table I, below. Section 5.11.1 provides details on each of the individual biomarkers. Section 5.11.2, below,

provides more details on select combinations of the biomarkers listed in Tables I, J, and K. Each of the biomarkers listed in Table I were selected based on the experimental results summarized in Sections 6.11 through 6.13. In some experiments, the identified biomarkers were proteins or fragments thereof. Such protein biomarkers, which discriminate between sepsis and SIRS, are listed in Table I with a "P" designation in column 5. In some experiments, the identified biomarkers were nucleic acids or fragment thereof. Such nucleic acid biomarkers, which discriminate between sepsis and SIRS, are listed in Table I with an "N" designation in column 5. As indicated above, one biomarker MMP9, was identified both as a protein and as a nucleic acid biomarker. Table J below lists the biomarkers in accordance with one embodiment of the present invention in which the biomarkers were discovered using nucleic acid based assays described in Section 6, such as RT-PCR. Table K below lists the biomarkers in accordance with one embodiment of the present invention in which the biomarkers were discovered using protein based assays, described in Section 6, such as bead assays. One embodiment of the invention comprises at least 3, 4, 5, 6, 7, 8, 9, or 10 biomarkers from any one of Tables 48, 59, or 93.

[0367] Unless indicated in specific embodiments below, the biomarkers of Tables I, J and K are not limited by their physical form in the experiments summarized in Sections 6.11 through 6.13. For example, although the discriminatory nature of a biomarker may have been discovered by the abundance of the biomarker, in nucleic acid form, in a nucleic acid assay such as RT-PCR and accordingly listed in Table I on this basis with an "N" designation in column 5 of Table I, the physical manifestation of the biomarker in the methods, kits, and biomarker profiles of the present invention is not limited to nucleic acids. Rather, any physical manifestation of the biomarker as defined for the term "biomarker" in Section 5.1 is encompassed in the present invention. Column 6 of Table I indicates, based on the data summarized in Section 6 below, whether the biomarker is up-regulated or down-regulated in the subjects that will convert to sepsis (the converters) relative to the subjects that will not convert (the SIRS subjects). Thus, if a biomarker has the designation UP, in column 6, that means that the biomarker, in the form indicated in column 5, was, on average, more abundant in subjects that will convert to sepsis (sepsis subjects) relative to subjects that will not convert to sepsis (SIRS subjects). Furthermore, if a biomarker has the designation DOWN, in column 6, that means that the biomarker, in the form indicated in column 5, was, on average, less abundant in subjects that will convert to sepsis (sepsis subjects), relative to subjects that will not convert to sepsis (SIRS subjects).

TABLE I

Biomarkers in accordance with an embodiment of the present invention.					
Gene Symbol	Gene Name	Gene Accession Number	Protein Accession Number	Regulation Source	Regulation in SEPSIS
1	2	3	4	5	6
AFP	ALPHA-FETOPROTEIN	NM_001134	CAA79592	P	UP
ANKRD22	ANKYRIN REPEAT DOMAIN 22	NM_144590	NP_653191	N	UP
ANXA3	ANNEXIN A3	NM_005139	NP_005130	N	UP
APOC3	APOLIPOPROTEIN CIII	NM_000040	CAA25648	P	DOWN
ARG2	ARGINASE TYPE II	NM_001172	CAG38787	N	UP

TABLE I-continued

Biomarkers in accordance with an embodiment of the present invention.					
Gene Symbol 1	Gene Name 2	Gene Accession Number 3	Protein Accession Number 4	Source 5	Regulation in SEPSIS 6
B2M	BETA-2 MICROGLOBULIN	NM_004048	AAA51811	P	UP
BCL2A1	BCL2-RELATED PROTEIN A1	NM_004049	NP_004040	N	UP
CCL5	CHEMOKINE (C-C MOTIF) LIGAND 5	NM_002985	NP_002976	N	DOWN
CD86	CD86 ANTIGEN (CD28 ANTIGEN LIGAND 2, B7-2 ANTIGEN)	NM_006889 NM_175862	NP_008820 NP_787058	N	DOWN
CEACAM1	CARCINOEMBRYONIC ANTIGEN-RELATED CELL ADHESION MOLECULE 1	NM_001712	NP_001703	N	UP
CRP	C REACTIVE PROTEIN	NM_000567	CAA39671	P	UP
CRTAP	CARTILAGE- ASSOCIATED PROTEIN	NM_006371	NP_006362	N	DOWN
CSF1R	COLONY STIMULATING FACTOR 1 RECEPTOR, FORMERLY MCDONOUGH FELINE SARCOMA VIRAL (V- FMS) ONCOGENE HOMOLOG	NM_005211	NP_005202	N	DOWN
FAD104	FIBRONECTIN TYPE III DOMAIN CONTAINING 3B (FNDC3B)	NM_022763	NP_073600	N	UP
FCGR1A	FC FRAGMENT OF IGG, HIGH AFFINITY IA	NM_000566	NP_000557	N	UP
GADD45A	GROWTH ARREST AND DNA-DAMAGE- INDUCIBLE, ALPHA	NM_001924	NP_001915	N	UP
GADD45B	GROWTH ARREST- AND DNA DAMAGE- INDUCIBLE GENE GADD45	NM_015675	NP_056490	N	UP
HLA-DRA	MAJOR HISTOCOMPATIBILITY COMPLEX, CLASS II, DR ALPHA	NM_002123	NP_002114	N	DOWN
IFNGR1	INTERFERON GAMMA RECEPTOR 1	NM_000416	NP_000407	N	UP
IL1RN	INTERLEUKIN = 1 RECEPTOR ANTAGONIST GENE	NM_000577, NM_173841, NM_173842, NM_173843	AAN87150	N	UP
IL-6	INTERLEUKIN 6	NM_000600	NP_000591	P	UP
IL-8	INTERLEUKIN 8	M28130	AAA59158	P	UP
IL-10	INTERLEUKIN 10	NM_000572	CAH73907	P	UP
IL10RA	INTERLEUKIN 10 RECEPTOR, ALPHA	NM_001558	NP_001549	N	DOWN
IL18R1	INTERLEUKIN 18 RECEPTOR 1	NM_003855	NP_003846	N	UP
INSL3	INSULIN-LIKE 3 (LEYDIG CELL)	NM_005543	NP_005534	N	UP
IRAK2	INTERLEUKIN-1 RECEPTOR- ASSOCIATED KINASE 2	NM_001570	NP_001561	N	UP
IRAK4	INTERLEUKIN-1 RECEPTOR- ASSOCIATED KINASE 4	NM_016123	NP_057207	N	UP
ITGAM	INTEGRIN, ALPHA M (COMPLEMENT COMPONENT RECEPTOR 3, ALPHA; ALSO KNOWN AS	NM_000632	NP_000623	N	UP

TABLE I-continued

Biomarkers in accordance with an embodiment of the present invention.					
Gene Symbol 1	Gene Name 2	Gene Accession Number 3	Protein Accession Number 4	Source 5	Regulation in SEPSIS 6
JAK2	CD11B (P170), MACROPHAGE ANTIGEN ALPHA POLYPEPTIDE) JANUS KINASE 2 (A PROTEIN TYROSINE KINASE)	NM_004972	NP_004963	N	UP
LDLR	LOW DENSITY LIPOPROTEIN RECEPTOR	NM_000527	NP_000518	N	UP
LY96	LYMPHOCYTE ANTIGEN 96	NM_015364	NP_056179	N	UP
MAP2K6	MITOGEN- ACTIVATED PROTEIN KINASE KINASE 6	NM_002758 NM_031988	NP_002749 NP_114365	N	UP
MAPK14	MAPK14 MITOGEN- ACTIVATED PROTEIN KINASE 14	NM_001315 NM_139012 NM_139013 NM_139014	NP_001306 NP_620581 NP_620582 NP_620583	N	UP
MCP1	MONOCYTE CHEMOATTRACTANT PROTEIN 1	AF493698, AF493697	AAQ75526	P	UP
MKNK1	MAP KINASE INTERACTING SERINE/THREONINE KINASE 1	NM_003684 NM_198973	NP_003675 NP_945324	N	UP
MMP9	MATRIX METALLOPROTEINASE 9 (GELATINASE B, 92 KDA GELATINASE, 92 KDA TYPE IV COLLAGENASE)	NM_004994	NP_004985	N/P	UP (both protein and nucleic acid)
NCR1	NATURAL CYTOTOXICITY TRIGGERING RECEPTOR 1	NM_004829	NP_004820	N	UP
OSM PFKFB3	ONCOSTATIN M 6-PHOSPHOFRUCTO- 2-KINASE/FRUCTOSE- 2,6-BISPHOSPHATASE 3	NM_020530 NM_004566	NP_065391 NP_004557	N N	UP UP
PRV1	NEUTROPHIL- SPECIFIC ANTIGEN 1 (POLYCYTHEMIA RUBRA VERA 1)	NM_020406	NP_065139	N	UP
PSTPIP2	PROLINE/SERINE/THREONINE PHOSPHATASE- INTERACTING PROTEIN 1 (PROLINE- SERINE-THREONINE PHOSPHATASE INTERACTING PROTEIN 2)	NM_024430	NP_077748	N	UP
SOCS3	SUPPRESSOR OF CYTOKINE SIGNALING 3	NM_003955	NP_003946	N	UP
SOD2	SUPEROXIDE DISMUTASE 2, MITOCHONDRIAL	NM_000636	NP_000627	N	UP
TDRD9	TUDOR DOMAIN CONTAINING 9	NM_153046	NP_694591	N	UP
TGFBI	TRANSFORMING GROWTH FACTOR, BETA-1 (TRANSFORMING GROWTH FACTOR, BETA-INDUCED, 68 KDA)	NM_000358	NP_000349	N	DOWN
TIFA	TRAF-INTERACTING PROTEIN WITH A	NM_052864	NP_443096	N	UP

TABLE I-continued

Biomarkers in accordance with an embodiment of the present invention.					
Gene Symbol 1	Gene Name 2	Gene Accession Number 3	Protein Accession Number 4	Source 5	Regulation in SEPSIS 6
TIMP1	FORKHEAD-ASSOCIATED DOMAIN TISSUE INHIBITOR OF METALLOPROTEINASE 1	NM_003254	AAA75558	P	UP
TLR4	TOLL-LIKE RECEPTOR 4	AH009665	AAF05316	N	UP
TNFRSF6	TUMOR NECROSIS FACTOR RECEPTOR SUPERFAMILY, MEMBER 6	NM_152877	NP_000034	N	UP
TNFSF10	TUMOR NECROSIS FACTOR (LIGAND) SUPERFAMILY, MEMBER 10	NM_003810	NP_003801	N	UP
TNFSF13B	TUMOR NECROSIS FACTOR (LIGAND) SUPERFAMILY, MEMBER 13B	NM_006573	NP_006564	N	UP
VNN1	VANIN 1	NM_004666	NP_004657	N	UP

[0368] Each of the sequences, genes, proteins, and probesets identified in Table I is hereby incorporated by reference.

TABLE J

Biomarkers identified based on the ability of the nucleic acid form of the biomarker to discriminate between SIRS and sepsis			
Gene Symbol 1	Gene Name 2	Gene Accession Number 3	Protein Accession Number 4
FCGR1A	FC FRAGMENT OF IGG, HIGH AFFINITY IA	NM_000566	NP_000557
MMP9	MATRIX METALLOPROTEINASE 9	NM_004994	NP_004985
IL18R1	INTERLEUKIN 18 RECEPTOR 1	NM_003855	NP_003846
ARG2	ARGINASE TYPE II	NM_001172	CAG38787
IL1RN	INTERLEUKIN-1 RECEPTOR ANTAGONIST GENE	NM_000577, NM_173841, NM_173842, NM_173843	AAN87150
TNFSF13B	TUMOR NECROSIS FACTOR SUPERFAMILY, MEMBER 13B	NM_006573	NP_006564
ITGAM	INTEGRIN, ALPHA M	NM_000632	NP_000623
TGFB1	TRANSFORMING GROWTH FACTOR, BETA-1	NM_000358	NP_000349
CD86	CD86 ANTIGEN	NM_006889 NM_175682	NP_008820 NP_787058
TLR4	TOLL-LIKE RECEPTOR 4	AH009665	AAF05316
	BCL2-RELATED PROTEIN A1	NM_004049	NP_004040
CCL5	CHEMOKINE (C-C MOTIF) LIGAND 5	NM_002985	NP_002976

TABLE J-continued

Biomarkers identified based on the ability of the nucleic acid form of the biomarker to discriminate between SIRS and sepsis			
Gene Symbol 1	Gene Name 2	Gene Accession Number 3	Protein Accession Number 4
CSF1R	COLONY STIMULATING FACTOR 1 RECEPTOR, FORMERLY MCDONOUGH FELINE SARCOMA VIRAL (V-FMS) ONCOGENE HOMOLOG	NM_005211	NP_005202
GADD45A	GROWTH ARREST AND DNA-DAMAGE-INDUCIBLE, ALPHA	NM_001924	NP_001915
GADD45B	GROWTH ARREST- AND DNA DAMAGE-INDUCIBLE GENE GADD45	NM_015675	NP_056490
IFNGR1	INTERFERON GAMMA RECEPTOR 1	NM_000416	NP_000407
IL10RA	INTERLEUKIN 10 RECEPTOR, ALPHA	NM_001558	NP_001549
IRAK2	INTERLEUKIN-1 RECEPTOR-ASSOCIATED KINASE 2	NM_001570	NP_001561
IRAK4	INTERLEUKIN-1 RECEPTOR-ASSOCIATED KINASE 4	NM_016123	NP_057207
JAK2	JANUS KINASE 2 (A PROTEIN TYROSINE KINASE)	NM_004972	NP_004963
LY96	LYMPHOCYTE ANTIGEN 96	NM_015364	NP_056179
MAP2K6	MITOGEN-ACTIVATED PROTEIN KINASE 6	NM_002758 NM_031988	NP_002749 NP_114365

TABLE J-continued

Biomarkers identified based on the ability of the nucleic acid form of the biomarker to discriminate between SIRS and sepsis			
Gene Symbol 1	Gene Name 2	Gene Accession Number 3	Protein Accession Number 4
MAPK14	MAPK14 MITOGEN-ACTIVATED PROTEIN KINASE 14	NM_001315 NM_139012 NM_139013 NM_139014	NP_001306 NP_620581 NP_620582 NP_620583
MKNK1	MAP KINASE INTERACTING SERINE/THREONINE KINASE 1	NM_003684 NM_198973	NP_003675 NP_945324
OSM	ONCOSTATIN M SUPPRESSOR OF CYTOKINE SIGNALING 3	NM_020530	NP_065391
SOCS3	TUDOR DOMAIN CONTAINING 9	NM_003955	NP_003946
TDRD9	TUMOR NECROSIS FACTOR RECEPTOR SUPERFAMILY, MEMBER 6	NM_153046	NP_694591
TNFRSF6	TUMOR NECROSIS FACTOR (LIGAND) SUPERFAMILY, MEMBER 10	NM_152877	NP_000034
TNFSF10	ANKYRIN REPEAT DOMAIN 22	NM_003810	NP_003801
ANKRD22	ANNEXIN A3	NM_144590	NP_653191
ANXA3	CARCINOEMBRYONIC ANTIGEN-RELATED CELL ADHESION MOLECULE 1	NM_005139 NM_001712	NP_005130 NP_001703
CEACAM1	LDLR	NM_000527	NP_000518
PFKFB3	6-PHOSPHOFRUCTO-2-KINASE/FRUCTOSE-2,6-BISPHOSPHATASE 3	NM_004566	NP_004557
PRV1	NEUTROPHIL-SPECIFIC ANTIGEN 1 (POLYCYTHEMIA RUBRA VERA 1)	NM_020406	NP_065139
PSTPIP2	PROLINE/SERINE/THREONINE PHOSPHATASE-INTERACTING PROTEIN 1 (PROLINE-SERINE-THREONINE PHOSPHATASE INTERACTING PROTEIN 2)	NM_024430	NP_077748
TIFA	TRAF-INTERACTING PROTEIN WITH A FORKHEAD-ASSOCIATED DOMAIN	NM_052864	NP_443096
VNN1	VANIN 1	NM_004666	NP004657
NCR1	NATURAL CYTOTOXICITY TRIGGERING RECEPTOR 1	NM_004829	NP_004820
FAD104	FIBRONECTIN TYPE III DOMAIN CONTAINING 3B (FNDC3B)	NM_022763	NP_073600
INSL3	INSULIN-LIKE 3 (LEYDIG CELL)	NM_005543	NP_005534
CRTAP	CARTILAGE-ASSOCIATED PROTEIN	NM_006371	NP_006362

TABLE J-continued

Biomarkers identified based on the ability of the nucleic acid form of the biomarker to discriminate between SIRS and sepsis			
Gene Symbol 1	Gene Name 2	Gene Accession Number 3	Protein Accession Number 4
HLA-DRA	MAJOR HISTOCOMPATIBILITY COMPLEX, CLASS II, DR ALPHA	NM_002123	NP_002114
SOD2	SUPEROXIDE DISMUTASE 2, MITOCHONDRIAL	NM_000636	NP_000627

TABLE K

Biomarkers identified based on the ability of the protein form of the biomarker to discriminate between SIRS and sepsis			
Gene Symbol 1	Gene Name 2	Gene Accession Number 3	Protein Accession Number 4
IL-6	INTERLEUKIN 6	NM_000600	NP_000591
IL-8	INTERLEUKIN 8	M28130	AAA59158
CRP	C Reactive protein	CAA39671	NM_000567
IL-10	INTERLEUKIN 10	NM_000572	CAH73907
APOC3	APOLIPOPROTEIN CIII	NM_000040	CAA25648
MMP9	MATRIX METALLOPROTEINASE 9 (GELATINASE B, 92 KDA GELATINASE, 92 KDA TYPE IV COLLAGENASE)	NM_004994	NP_004985
TIMP1	TISSUE INHIBITOR OF METALLOPROTEINASE 1	NM_003254	AAA75558
MCPI	MONOCYTE CHEMOATTRACTANT PROTEIN 1	AF493698, AF493697	AAQ75526
AFP	ALPHA-FETOPROTEIN	NM_001134	CAA79592
B2M	BETA-2 MICROGLOBULIN	NM_004048	AAA51811

5.11.1 Biomarker Descriptions

[0369] The references for the biomarkers in this section merely provide exemplary sequences for the biomarkers set forth in the present application.

[0370] The nucleotide sequence of AFP (identified by accession no. NM_001134) is disclosed in, e.g., Beattie et al., 1982, "Structure and evolution of human alpha-fetoprotein deduced from partial sequence of cloned cDNA" Gene 20 (3): 415-422, Harper, M. E. et al., 1983, "Linkage of the evolutionarily-related serum albumin and alpha-fetoprotein genes within q11-22 of human chromosome 4," Am. J. Hum. Genet. 35 (4):565-572, Morinaga, T. et al., 1983, "Primary structures of human alpha-fetoprotein and its mRNA," Proc. Natl. Acad. Sci. U.S.A. 80 (15):4604-4608, and the amino acid sequence of AFP (identified by accession no. CAA79592) is disclosed in, e.g., McVey, 1993, Direct Submission, Clinical Research Centre, Haemostasis Research Group, Watford Road, Harrow, UK, HAI 3UJ, McVey et al., 1993, "A G->A substitution in an HNF I binding site in the human alpha-fetoprotein gene is associated with hereditary persistence of alpha-fetoprotein (HPAFP)," Hum. Mol.

Genet. 2 (4): 379-384, each of which is incorporated by reference herein in its entirety.

[0371] The nucleotide sequence of ANKRD22 (identified by accession no. NM_144590) is disclosed in, e.g., Strausberg, 2002, "*Homo sapiens* ankyrin repeat domain 22, mRNA (cDNA clone MGC:22805 IMAGE:3682099)," unpublished, and the amino acid sequence of ANKRD22 (identified by accession no. NP_653191) is disclosed in, e.g., Strausberg, 2002, "*Homo sapiens* ankyrin repeat domain 22, mRNA (cDNA clone MGC:22805 IMAGE:3682099)," unpublished, each of which is incorporated by reference herein in its entirety.

[0372] The nucleotide sequence of ANXA3 (identified by accession no. NM_005139) is disclosed in, e.g., Pepinsky, R. B. et al., 1988, "Five distinct calcium and phospholipid binding proteins share homology with lipocortin I," J. Biol. Chem. 263 (22): 10799-10811, Tait, J. F. et al., 1988, "Placental anticoagulant proteins: isolation and comparative characterization four members of the lipocortin family," Biochemistry 27 (17):6268-6276, Ross, T. S. et al., 1990, "Identity of inositol 1,2-cyclic phosphate 2-phosphohydrolase with lipocortin III," Science 248 (4955):605-607, and the amino acid sequence of ANXA3 (identified by accession no. NP_005130) is disclosed in, e.g., Pepinsky, R. B. et al., 1988, "Five distinct calcium and phospholipid binding proteins share homology with lipocortin I," J. Biol. Chem. 263 (22): 10799-10811, Tait, J. F. et al., 1988, "Placental anticoagulant proteins: isolation and comparative characterization four members of the lipocortin family," Biochemistry 27 (17):6268-6276, Ross, T. S. et al., 1990, "Identity of inositol 1,2-cyclic phosphate 2-phosphohydrolase with lipocortin III," Science 248 (4955):605-607, each of which is incorporated by reference herein in its entirety.

[0373] The nucleotide sequence of Apolipoprotein CIII (APOC3) (identified by accession no. NM_000040) is disclosed in, e.g., Ruiz-Narvaez, et al., 2005 "APOC3/A5 haplotypes, lipid levels, and risk of myocardial infarction in the Central Valley of Costa Rica," J. Lipid Res. 46 (12), 2605-2613; Garenc et al., 2005, "Effect of the APOC3 Sst I SNP on fasting triglyceride levels in men heterozygous for the LPL P207L deficiency," Eur. J. Hum. Genet. 13, 1159-1165; Baum, et al., 2005, "Effect of hepatic lipase -514C->T polymorphism and its interactions with apolipoprotein C₃₋₄₈₂C->T and apolipoprotein E exon 4 polymorphisms on the risk of nephropathy in chinese type 2 diabetic patients," Diabetes Care 28, 1704-1709, and the amino acid sequence of APOC3 (identified by accession no. CAA25648) is disclosed in, e.g., Proffer et al., 1984, "Isolation and sequence analysis of the human apolipoprotein CIII gene and the intergenic region between the apo AI and apo CIII," DNA 3, 449-456, each of which is incorporated by reference herein in its entirety.

[0374] The nucleotide sequence of ARG2 (identified by accession no. NM_001172) is disclosed in, e.g., Gotoh et al., 1996 "Molecular cloning of cDNA for nonhepatic mitochondrial arginase(arginase II) and comparison of its induction with nitric oxide synthase in a murine macrophage-like cell line," FEBS Lett. 395 (2-3):119-122, Vockley et al., 1996, "Cloning and characterization of the human type II arginase gene," Genomics 38 (2):118-123, Gotoh et al., 1997, "Chromosomal localization of the human arginase II gene and tissue distribution of its mRNA," Biochem. Biophys. Res. Commun. 233 (2):487-491, and the amino acid sequence of ARG2 (identified by accession no. CAG38787) is disclosed in, e.g., Halleck et al., 2004, Direct Submission, RZPD Deut-

sches Ressourcenzentrum fuer Genomforschung GmbH, Im Neuenheimer Feld 580, D-69120 Heidelberg, Germany, Halleck et al., unpublished, "Cloning of human full open reading frames in Gateway™ system entry vector (pDONR201)," each of which is incorporated by reference herein in its entirety.

[0375] The nucleotide sequence of B2M (identified by accession no. NM_004048) is disclosed in, e.g., Krangel, M. S. et al., 1979, "Assembly and maturation of HLA-A and HLA-B antigens in vivo," Cell 18 (4):979-991, Suggs, S. V. et al., 1981, "Use of synthetic oligonucleotides as hybridization probes: isolation of cloned cDNA sequences for human beta 2-microglobulin," Proc. Natl. Acad. Sci. U.S.A. 78 (11): 6613-6617, Rosa, F. et al., 1983, "The beta2-microglobulin mRNA in human Daudi cells has a mutated initiation codon but is still inducible by interferon," EMBO J. 2 (2):239-243, and the amino acid sequence of B2M (identified by accession no. AAA51811) is disclosed in, e.g., Gussow, D. et al., 1987, "The human beta 2-microglobulin gene. Primary structure and definition of the transcriptional unit," J. Immunol. 139 (9): 3132-3138, each of which is incorporated by reference herein in its entirety.

[0376] The nucleotide sequence of BCL2A1 (identified by accession no. NM_004049) is disclosed in, e.g., Lin, E. Y. et al., 1993, "Characterization of A1, a novel hemopoietic-specific early-response gene with sequence similarity to bcl-2," J. Immunol. 151 (4):1979-1988, Savitsky, K. et al., "The complete sequence of the coding region of the ATM gene reveals similarity to cell cycle regulators in different species," Hum. Mol. Genet. 4 (11):2025-2032, Choi, S. S. et al., 1995, "A novel Bcl-2 related gene, Bfl-1, is overexpressed in stomach cancer and preferentially expressed in bone marrow," Oncogene 11 (9):1693-1698, and the amino acid sequence of BCL2A1 (identified by accession no. NP_004040) is disclosed in, e.g., Lin, E. Y. et al., 1993, "Characterization of A1, a novel hemopoietic-specific early-response gene with sequence similarity to bcl-2," J. Immunol. 151 (4):1979-1988, Savitsky, K. et al., "The complete sequence of the coding region of the ATM gene reveals similarity to cell cycle regulators in different species," Hum. Mol. Genet. 4 (11): 2025-2032, Choi, S. S. et al., 1995, "A novel Bcl-2 related gene, Bfl-1, is overexpressed in stomach cancer and preferentially expressed in bone marrow," Oncogene 11 (9):1693-1698, each of which is incorporated by reference herein in its entirety.

[0377] The nucleotide sequence of CCL5 (identified by accession no. NM_002985) is disclosed in, e.g., Schall, T. J. et al., 1988, "A human T cell-specific molecule is a member of a new gene family," J. Immunol. 141 (3):1018-1025, Donlon, T. A. et al., 1990, "Localization of a human T-cell-specific gene, RANTES (D17S136E), to chromosome 17q11.2-q12," Genomics 6 (3):548-553, Kameyoshi, Y. et al., 1992, "Cytokine RANTES released by thrombin-stimulated platelets is a potent attractant for human eosinophils," J. Exp. Med. 176 (2):587-592, and the amino acid sequence of CCL5 (identified by accession no. NP_002976) is disclosed in, e.g., Schall, T. J. et al., 1988, "A human T cell-specific molecule is a member of a new gene family," J. Immunol. 141 (3):1018-1025, Donlon, T. A. et al., 1990, "Localization of a human T-cell-specific gene, RANTES (D17S136E), to chromosome 17q11.2-q12," Genomics 6 (3):548-553, Kameyoshi, Y. et al., 1992, "Cytokine RANTES released by thrombin-stimulated platelets is a potent attractant for human eosinophils," J. Exp.

Med. 176 (2):587-592, each of which is incorporated by reference herein in its entirety.

[0378] The nucleotide sequence of CD86 (identified by accession nos. NM_006889, NM_175862) is disclosed in, e.g., Azuma, M. et al., 1993, "B70 antigen is a second ligand for CTLA-4 and CD28," *Nature* 366 (6450):76-79, Freeman, G. J. et al., 1993, "Cloning of B7-2: a CTLA-4 counter-receptor that costimulates human T cell proliferation," *Science* 262 (5135):909-911, Chen, C. et al., 1994, "Molecular cloning and expression of early T cell costimulatory molecule-1 and its characterization as B7-2 molecule," *J. Immunol.* 152 (10):4929-4936, and the amino acid sequence of CD86 (identified by accession nos. NP_008820, NP_787058) is disclosed in, e.g., Azuma, M. et al., 1993, "B70 antigen is a second ligand for CTLA-4 and CD28," *Nature* 366 (6450):76-79, Azuma, M. et al., 1993, "B70 antigen is a second ligand for CTLA-4 and CD28," *Nature* 366 (6450):76-79, Freeman, G. J. et al., 1993, "Cloning of B7-2: a CTLA-4 counter-receptor that costimulates human T cell proliferation," *Science* 262 (5135):909-911, Chen, C. et al., 1994, "Molecular cloning and expression of early T cell costimulatory molecule-1 and its characterization as B7-2 molecule," *J. Immunol.* 152 (10):4929-4936, each of which is incorporated by reference herein in its entirety.

[0379] The nucleotide sequence of CEACAM1 (identified by accession no. NM_001712) is disclosed in, e.g., Svenberg, T. et al., 1979, "Immunofluorescence studies on the occurrence and localization of the CEA-related biliary glycoprotein I (BGP I) in normal human gastrointestinal tissues," *Clin. Exp. Immunol.* 36 (3):436-441, Hinoda, Y. et al., 1988, "Molecular cloning of a cDNA coding biliary glycoprotein I: primary structure of a glycoprotein immunologically cross-reactive with carcinoembryonic antigen," *Proc. Natl. Acad. Sci. U.S.A.* 85 (18):6959-6963, Barnett, T. R. et al., 1989, "Carcinoembryonic antigens: alternative splicing accounts for the multiple mRNAs that code for novel members of the carcinoembryonic antigen family," *J. Cell Biol.* 108 (2):267-276, and the amino acid sequence of CEACAM1 (identified by accession no. NP_001703) is disclosed in, e.g., Svenberg, T. et al., 1979, "Immunofluorescence studies on the occurrence and localization of the CEA-related biliary glycoprotein I (BGP I) in normal human gastrointestinal tissues," *Clin. Exp. Immunol.* 36 (3):436-441, Hinoda, Y. et al., 1988, "Molecular cloning of a cDNA coding biliary glycoprotein I: primary structure of a glycoprotein immunologically cross-reactive with carcinoembryonic antigen," *Proc. Natl. Acad. Sci. U.S.A.* 85 (18):6959-6963, Barnett, T. R. et al., 1989, "Carcinoembryonic antigens: alternative splicing accounts for the multiple mRNAs that code for novel members of the carcinoembryonic antigen family," *J. Cell Biol.* 108 (2):267-276, each of which is incorporated by reference herein in its entirety.

[0380] The nucleotide sequence of C Reactive Protein (CRP) (identified by accession no. NM_000567) is disclosed in, e.g., Song et al., 2006, "C-reactive protein contributes to the hypercoagulable state in coronary artery disease," *J. Thromb. Haemost.* 4 (1), 98-106; Wakugawa et al., 2006, "C-reactive protein and risk of first-ever ischemic and hemorrhagic stroke in a general Japanese population: the Hisayama Study," *Stroke* 37, 27-32; Tong et al., 2005, "Association of testosterone, insulin-like growth factor-I, and C-reactive protein with metabolic syndrome in Chinese middle-aged men with a family history of type 2 diabetes," *J. Clin. Endocrinol. Metab.* 90, 6418-6423, and the amino acid

sequence of CRP (identified by accession no. CAA39671 is described in a direct submission by Tenchini et al., 1990, Tenchini M.L., Dipartimento di Biologia e Genetica per le Scienze mediche, via Viotti 3, 20133 Milano, Italy, each of which is incorporated by reference herein in its entirety.

[0381] The nucleotide sequence of CRTAP (identified by accession no. NM_006371) is disclosed in, e.g., Castagnola, P. et al., 1997, "Cartilage associated protein (CASP) is a novel developmentally regulated chick embryo protein," *J. Cell. Sci.* 110 (PT 12):1351-1359; Tonachini, L. et al., 1999, "cDNA cloning, characterization and chromosome mapping of the gene encoding human cartilage associated protein (CRTAP)," *Cytogenet. Cell Genet.* 87:(3-4); Morello, R. et al., 1999, "cDNA cloning, characterization and chromosome mapping of Crtap encoding the mouse cartilage associated protein," *Matrix Biol.* 18 (3):319-324, and the amino acid sequence of CRTAP (identified by accession no. NP_006362) is disclosed in, e.g., Castagnola, P. et al., 1997, "Cartilage associated protein (CASP) is a novel developmentally regulated chick embryo protein," *J. Cell. Sci.* 110 (PT 12):1351-1359, Tonachini, L. et al., 1999, "cDNA cloning, characterization and chromosome mapping of the gene encoding human cartilage associated protein (CRTAP)," *Cytogenet. Cell Genet.* 87:(3-4); Morello, R. et al., 1999, "cDNA cloning, characterization and chromosome mapping of Crtap encoding the mouse cartilage associated protein," *Matrix Biol.* 18 (3):319-324, each of which is incorporated by reference herein in its entirety.

[0382] The nucleotide sequence of CSF1R (identified by accession no. NM_005211) is disclosed in, e.g., Verbeek, J. S. et al., 1985, "Human c-fms proto-oncogene: comparative analysis with an abnormal allele," *Mol. Cell. Biol.* 5 (2):422-426; Xu, D. Q. et al., 1985, "Restriction fragment length polymorphism of the human c-fms gene," *Proc. Natl. Acad. Sci. U.S.A.* 82 (9):2862-2865; Sherr, C. J. et al., 1985, "The c-fms proto-oncogene product is related to the receptor for the mononuclear phagocyte growth factor, CSF-1," *Cell* 41 (3):665-676, and the amino acid sequence of CSF1R (identified by accession no. NP_005202) is disclosed in, e.g., Verbeek, J. S. et al., 1985, "Human c-fms proto-oncogene: comparative analysis with an abnormal allele," *Mol. Cell. Biol.* 5 (2):422-426, Xu, D. Q. et al., 1985, "Restriction fragment length polymorphism of the human c-fms gene," *Proc. Natl. Acad. Sci. U.S.A.* 82 (9):2862-2865, Sherr, C. J. et al., 1985, "The c-fms proto-oncogene product is related to the receptor for the mononuclear phagocyte growth factor, CSF-1," *Cell* 41 (3):665-676, each of which is incorporated by reference herein in its entirety.

[0383] The nucleotide sequence of FAD104 (identified by accession no. NM_022763) is disclosed in, e.g., Clark, H. F. et al., 2003, "The secreted protein discovery initiative (SPDI), a large-scale effort to identify novel human secreted and transmembrane proteins: a bioinformatics assessment," *Genome Res.* 13 (10):2265-2270, Tominaga, K. et al., 2004, "The novel gene fad104, containing a fibronectin type III domain, has a significant role in adipogenesis," *FEBS Lett.* 577 (1-2):49-54, and the amino acid sequence of FAD104 (identified by accession no. NP_073600) is disclosed in, e.g., Clark, H. F. et al., 2003, "The secreted protein discovery initiative (SPDI), a large-scale effort to identify novel human secreted and transmembrane proteins: a bioinformatics assessment," *Genome Res.* 13 (10):2265-2270, Tominaga, K. et al., 2004, "The novel gene fad104, containing a fibronectin

type III domain, has a significant role in adipogenesis." FEBS Lett. 577 (1-2):49-54, each of which is incorporated by reference herein in its entirety.

[0384] The nucleotide sequence of FCGR1A (identified by accession no. NM_000566) is disclosed in, e.g., Eizuru, Y. et al., 1988, "Induction of Fc (IgG) receptor(s) by simian cytomegaloviruses in human embryonic lung fibroblasts," *Intervirology* 29 (6):339-345, Allen, J. M. et al., 1988, "Nucleotide sequence of three cDNAs for the human high affinity Fc receptor (FcRI)," *Nucleic Acids Res.* 16 (24):11824, van de Winkel, J. G. et al., 1991, "Gene organization of the human high affinity receptor for IgG, Fc gamma RI (CD64). Characterization and evidence for a second gene," *J. Biol. Chem.* 266 (20):13449-1345, and the amino acid sequence of FCGR1A (identified by accession no. NP_000557) is disclosed in, e.g., Eizuru, Y. et al., 1988, "Induction of Fc (IgG) receptor(s) by simian cytomegaloviruses in human embryonic lung fibroblasts," *Intervirology* 29 (6):339-345, Allen, J. M. et al., 1988, "Nucleotide sequence of three cDNAs for the human high affinity Fc receptor (FcRI)," *Nucleic Acids Res.* 16 (24):11824, van de Winkel, J. G. et al., 1991, "Gene organization of the human high affinity receptor for IgG, Fc gamma RI (CD64). Characterization and evidence for a second gene," *J. Biol. Chem.* 266 (20):13449-1345, each of which is incorporated by reference herein in its entirety.

[0385] The nucleotide sequence of GADD45A (identified by accession no. NM_001924) is disclosed in, e.g., Papathanasiou, M. A. et al., 1991, "Induction by ionizing radiation of the gadd45 gene in cultured human cells: lack of mediation by protein kinase C," *Mol. Cell. Biol.* 11 (2):1009-1016, Hollander, M. C. et al., 1993, "Analysis of the mammalian gadd45 gene and its response to DNA damage," *J. Biol. Chem.* 268 (32):24385-24393, Smith, M. L. et al., 1994, "Interaction of the p53-regulated protein Gadd45 with proliferating cell nuclear antigen," *Science* 266 (5189):1376-1380, and the amino acid sequence of GADD45A (identified by accession no. NP_001915) is disclosed in, e.g., Papathanasiou, M. A. et al., 1991, "Induction by ionizing radiation of the gadd45 gene in cultured human cells: lack of mediation by protein kinase C," *Mol. Cell. Biol.* 11 (2):1009-1016, Hollander, M. C. et al., 1993, "Analysis of the mammalian gadd45 gene and its response to DNA damage," *J. Biol. Chem.* 268 (32):24385-24393, Smith, M. L. et al., 1994, "Interaction of the p53-regulated protein Gadd45 with proliferating cell nuclear antigen," *Science* 266 (5189):1376-1380, each of which is incorporated by reference herein in its entirety.

[0386] The nucleotide sequence of GADD45B (identified by accession no. NM_015675) is disclosed in, e.g., Abdollahi, A. et al., 1991, "Sequence and expression of a cDNA encoding MyD118: a novel myeloid differentiation primary response gene induced by multiple cytokines," *Oncogene* 6 (1): 165-167, Vairapandi, M. et al., 1996, "The differentiation primary response gene MyD118, related to GADD45, encodes for a nuclear protein which interacts with PCNA and p21WAF1/CIP1," *Oncogene* 12 (12):2579-2594, Koonin, E. V., 1997, "Cell cycle and apoptosis: possible roles of Gadd45 and MyD118 proteins inferred from their homology to ribosomal proteins," *J. Mol. Med.* 75 (4):236-238, and the amino acid sequence of GADD45B (identified by accession no. NP_056490) is disclosed in, e.g., Abdollahi, A. et al., 1991, "Sequence and expression of a cDNA encoding MyD118: a novel myeloid differentiation primary response gene induced

by multiple cytokines," *Oncogene* 6 (1):165-167, Vairapandi, M. et al., 1996, "The differentiation primary response gene MyD118, related to GADD45, encodes for a nuclear protein which interacts with PCNA and p21WAF1/CIP1," *Oncogene* 12 (12):2579-2594, Koonin, E. V., 1997, "Cell cycle and apoptosis: possible roles of Gadd45 and MyD118 proteins inferred from their homology to ribosomal proteins," *J. Mol. Med.* 75 (4):236-238, each of which is incorporated by reference herein in its entirety.

[0387] The nucleotide sequence of HLA-DRA (identified by accession no. NM_002123) is disclosed in, e.g., Larhammar, D. et al., 1981, Evolutionary relationship between HLA-DR antigen beta-chains, HLA-A, B, C antigen subunits and immunoglobulin chains," *Scand. J. Immunol.* 14 (6):617-622, Wiman, K. et al., 1982, "Isolation and identification of a cDNA clone corresponding to an HLA-DR antigen beta chain," *Proc. Natl. Acad. Sci. U.S.A.* 79 (6):1703-1707, Larhammar, D. et al., 1982, "Complete amino acid sequence of an HLA-DR antigen-like beta chain as predicted from the nucleotide sequence: similarities with immunoglobulins and HLA-A, -B, and -C antigens," *Proc. Natl. Acad. Sci. U.S.A.* 79 (12):3687-3691, and the amino acid sequence of HLA-DRA (identified by accession no. NP_002114) is disclosed in, e.g., Larhammar, D. et al., 1981, Evolutionary relationship between HLA-DR antigen beta-chains, HLA-A, B, C antigen subunits and immunoglobulin chains," *Scand. J. Immunol.* 14 (6):617-622, Wiman, K. et al., 1982, "Isolation and identification of a cDNA clone corresponding to an HLA-DR antigen beta chain," *Proc. Natl. Acad. Sci. U.S.A.* 79 (6):1703-1707, Larhammar, D. et al., 1982, "Complete amino acid sequence of an HLA-DR antigen-like beta chain as predicted from the nucleotide sequence: similarities with immunoglobulins and HLA-A, -B, and -C antigens," *Proc. Natl. Acad. Sci. U.S.A.* 79 (12):3687-3691, each of which is incorporated by reference herein in its entirety.

[0388] The nucleotide sequence of IFNGR1 (identified by accession no. NM_000416) is disclosed in, e.g., Novick, D. et al., 1987, "The human interferon-gamma receptor. Purification, characterization, and preparation of antibodies, each of which is incorporated by reference herein in its entirety," *J. Biol. Chem.* 262 (18): 8483-8487, Aguet, M. et al., 1988, "Molecular cloning and expression of the human interferon-gamma receptor," *Cell* 55 (2): 273-280, Le Coniat, M. et al., 1989, "Human interferon gamma receptor 1 (IFNGR1) gene maps to chromosome region 6q23-6q24," *Hum. Genet.* 84 (1):92-94, and the amino acid sequence of IFNGR1 (identified by accession no. NP_000407) is disclosed in, e.g., Novick, D. et al., 1987, "The human interferon-gamma receptor. Purification, characterization, and preparation of antibodies," *J. Biol. Chem.* 262 (18):8483-8487, Aguet, M. et al., 1988, "Molecular cloning and expression of the human interferon-gamma receptor," *Cell* 55 (2): 273-280, Le Coniat, M. et al., 1989, "Human interferon gamma receptor 1 (IFNGR1) gene maps to chromosome region 6q23-6q24," *Hum. Genet.* 84 (1):92-94, each of which is incorporated by reference herein in its entirety.

[0389] The nucleotide sequence of IL (identified by accession nos. NM_000577, NM_173841, NM_173842, NM_173843) is disclosed in, e.g., Eisenberg, S. P. et al., 1990, "Primary structure and functional expression from complementary DNA of a human interleukin-1 receptor antagonist," *Nature* 343 (6256):341-346, Carter, D. B. et al., 1990, "Purification, cloning, expression and biological characterization of an interleukin-1 receptor antagonist protein,"

Nature 344 (6267):633-638, Seckinger, P. et al., 1990, "Natural and recombinant human IL-1 receptor antagonists block the effects of IL-1 on bone resorption and prostaglandin production," J. Immunol. 145 (12):4181-4184, and the amino acid sequence of IL1RN (identified by accession no. AAN87150) is disclosed in, e.g., Rieder, M. J. et al., 2002, Direct Submission, Genome Sciences, University of Washington, 1705 NE Pacific, Seattle, Wash. 98195, USA, each of which is incorporated by reference herein in its entirety.

[0390] The nucleotide sequence of IL-6 (identified by accession no. NM_000600) is disclosed in, e.g., Haegeman, G. et al., 1986, "Structural analysis of the sequence coding for an inducible 26-kDa protein in human fibroblasts," Eur. J. Biochem. 159 (3):625-632, Zilberstein, A. et al., 1986, "Structure and expression of cDNA and genes for human interferon-beta-2, a distinct species inducible by growth-stimulatory cytokines," EMBO J. 5 (10):2529-2537, Hirano, T. et al., 1986, "Complementary DNA for a novel human interleukin (BSF-2) that induces B lymphocytes to produce immunoglobulin," Nature 324 (6092):73-76, and the amino acid sequence of IL-6 (identified by accession no. NP_000591) is disclosed in, e.g., Haegeman, G. et al., 1986, "Structural analysis of the sequence coding for an inducible 26-kDa protein in human fibroblasts," Eur. J. Biochem. 159 (3):625-632, Zilberstein, A. et al., 1986, "Structure and expression of cDNA and genes for human interferon-beta-2, a distinct species inducible by growth-stimulatory cytokines," EMBO J. 5 (10):2529-2537, Hirano, T. et al., 1986, "Complementary DNA for a novel human interleukin (BSF-2) that induces B lymphocytes to produce immunoglobulin," Nature 324 (6092):73-76, each of which is incorporated by reference herein in its entirety.

[0391] The nucleotide sequence of IL-8 (identified by accession no. M28130) and the amino acid sequence of IL-8 (identified by accession no. AAA59158) are each disclosed in, e.g., Mukaida et al., 1989, "Genomic structure of the human monocyte-derived neutrophil chemotactic factor IL-8," J. Immunol. 143, 1366-1371 which is incorporated by reference herein in its entirety.

[0392] The nucleotide sequence of IL-10 (identified by accession no. NM_000572) is disclosed in, e.g., Ghosh, S. et al., 1975, "Anaerobic acidogenesis of wastewater sludge," Breast Cancer Res. Treat. 47 (1):30-45, Hsu, D. H. et al., 1990, "Expression of interleukin-10 activity by Epstein-Barr virus protein BCRF1," Science 250 (4982):830-832, Vieira, P. et al., 1991, "Isolation and expression of human cytokine synthesis inhibitory factor cDNA clones: homology to Epstein-Barr virus open reading frame BCRF1," Proc. Natl. Acad. Sci. U.S.A. 88 (4):1172-1176, and the amino acid sequence of IL-10 (identified by accession no. CAH73907) is disclosed in, e.g., Tracey, A., 2005, Direct Submission, Wellcome Trust Sanger Institute, Hinxton, Cambridgeshire, CB 10 1SA, each of which is incorporated by reference herein in its entirety.

[0393] The nucleotide sequence of IL10RA (identified by accession no. NM_001558) is disclosed in, e.g., Tan, J. C. et al., 1993, "Characterization of interleukin-10 receptors on human and mouse cells," J. Biol. Chem. 268 (28):21053-21059, Ho, A. S. et al., 1993, "A receptor for interleukin 10 is related to interferon receptors," Proc. Natl. Acad. Sci. U.S.A. 90 (23):11267-11271, Liu, Y. et al., 1994, "Expression cloning and characterization of a human IL-10 receptor," J. Immunol. 152 (4):1821-1829, and the amino acid sequence of IL10RA (identified by accession no. NP_001549) is dis-

closed in, e.g., Tan, J. C. et al., 1993, "Characterization of interleukin-10 receptors on human and mouse cells," J. Biol. Chem. 268 (28):21053-21059, Ho, A. S. et al., 1993, "A receptor for interleukin 10 is related to interferon receptors," Proc. Natl. Acad. Sci. U.S.A. 90 (23):11267-11271, Liu, Y. et al., 1994, "Expression cloning and characterization of a human IL-10 receptor," J. Immunol. 152 (4):1821-1829, each of which is incorporated by reference herein in its entirety.

[0394] The nucleotide sequence of IL18R1 (identified by accession no. NM_003855) is disclosed in, e.g., Parnet, P. et al., 1996, "IL-1Rrp is a novel receptor-like molecule similar to the type I interleukin-1 receptor and its homologues T1/ST2 and IL-1R AcP," J. Biol. Chem. 271 (8):3967-3970, Lovenberg, T. W. et al., 1996, "Cloning of a cDNA encoding a novel interleukin-1 receptor related protein (IL 1R-rp2)," J. Neuroimmunol. 70 (2):113-122, Torigoe, K. et al., 1997, "Purification and characterization of the human interleukin-18 receptor," J. Biol. Chem. 272 (41):25737-25742, and the amino acid sequence of IL18R1 (identified by accession no. NP_003846) is disclosed in, e.g., Parnet, P. et al., 1996, "IL-1Rrp is a novel receptor-like molecule similar to the type I interleukin-1 receptor and its homologues T1/ST2 and IL-1R AcP," J. Biol. Chem. 271 (8):3967-3970, Lovenberg, T. W. et al., 1996, "Cloning of a cDNA encoding a novel interleukin-1 receptor related protein (IL1R-rp2)," J. Neuroimmunol. 70 (2):113-122, Torigoe, K. et al., 1997, "Purification and characterization of the human interleukin-18 receptor," J. Biol. Chem. 272 (41):25737-25742, each of which is incorporated by reference herein in its entirety.

[0395] The nucleotide sequence of INSL3 (identified by accession no. NM_005543) is disclosed in, e.g., Adham, I. M. et al., 1993, "Cloning of a cDNA for a novel insulin-like peptide of the testicular Leydig cells," J. Biol. Chem. 268 (35):26668-26672, Burkhardt, E. et al., 1994, "Structural organization of the porcine and human genes coding for a Leydig cell-specific insulin-like peptide (LEY I-L) and chromosomal localization of the human gene (INSL3)," Genomics 20 (1):13-19, Burkhardt, E. et al., 1994, "A human cDNA coding for the Leydig insulin-like peptide (Ley I-L)," Hum. Genet. 94 (1):91-94, and the amino acid sequence of INSL3 (identified by accession no. NP_005534) is disclosed in, e.g., Adham, I. M. et al., 1993, "Cloning of a cDNA for a novel insulin-like peptide of the testicular Leydig cells," J. Biol. Chem. 268 (35):26668-26672, Burkhardt, E. et al., 1994, "Structural organization of the porcine and human genes coding for a Leydig cell-specific insulin-like peptide (LEY I-L) and chromosomal localization of the human gene (INSL3)," Genomics 20 (1):13-19, Burkhardt, E. et al., 1994, "A human cDNA coding for the Leydig insulin-like peptide (Ley I-L)," Hum. Genet. 94 (1):91-94, each of which is incorporated by reference herein in its entirety.

[0396] The nucleotide sequence of IRAK2 (identified by accession no. NM_001570) is disclosed in, e.g., Muzio, M. et al., 1997, "IRAK (Pelle) family member IRAK-2 and MyD88 as proximal mediators of IL-1 signaling," Science 278 (5343):1612-1615, Auron, P.E., 1998, "The interleukin 1 receptor: ligand interactions and signal transduction," Cytokine Growth Factor Rev. 9 (3-4):221-237, Maschera, B. et al., 1999, "Overexpression of an enzymically inactive interleukin-1-receptor-associated kinase activates nuclear factor-kappaB," Biochem. J. 339 (PT 2):227-231, and the amino acid sequence of IRAK2 (identified by accession no. NP_001561) is disclosed in, e.g., Muzio, M. et al., 1997, "IRAK (Pelle) family member IRAK-2 and MyD88 as proxi-

mal mediators of IL-1 signaling,” *Science* 278 (5343):1612-1615, Auron, P.E., 1998, “The interleukin 1 receptor: ligand interactions and signal transduction,” *Cytokine Growth Factor Rev.* 9 (3-4):221-237, Maschera, B. et al., 1999, “Overexpression of an enzymically inactive interleukin-1-receptor-associated kinase activates nuclear factor-kappaB,” *Biochem. J.* 339 (PT 2):227-231, each of which is incorporated by reference herein in its entirety.

[0397] The nucleotide sequence of IRAK4 (identified by accession no. NM_016123) is disclosed in, e.g., Siu, G. et al., 1986, “Analysis of a human V beta gene subfamily,” *J. Exp. Med.* 164 (5):1600-1614, Scanlan, M. J. et al., 1999, “Antigens recognized by autologous antibody in patients with renal-cell carcinoma,” *Int. J. Cancer* 83 (4):456-464, Li, S. et al., 2002, “IRAK-4: a novel member of the IRAK family with the properties of an IRAK-kinase,” *Proc. Natl. Acad. Sci. U.S.A.* 99 (8):5567-5572, and the amino acid sequence of IRAK4 (identified by accession no. NP_057207) is disclosed in, e.g., Siu, G. et al., 1986, “Analysis of a human V beta gene subfamily,” *J. Exp. Med.* 164 (5):1600-1614, Scanlan, M. J. et al., 1999, “Antigens recognized by autologous antibody in patients with renal-cell carcinoma,” *Int. J. Cancer* 83 (4):456-464, Li, S. et al., 2002, “IRAK-4: a novel member of the IRAK family with the properties of an IRAK-kinase,” *Proc. Natl. Acad. Sci. U.S.A.* 99 (8):5567-5572, each of which is incorporated by reference herein in its entirety.

[0398] The nucleotide sequence of ITGAM (identified by accession no. NM_000632) is disclosed in, e.g., Micklem, K. J. et al., 1985, “Isolation of complement-fragment-iC3b-binding proteins by affinity chromatography. The identification of p150,95 as an iC3b-binding protein,” *Biochem. J.* 231 (1):233-236, Pierce, M. W. et al., 1986, “N-terminal sequence of human leukocyte glycoprotein Mol:conservation across species and homology to platelet IIb/IIIa,” *Biochim. Biophys. Acta* 874 (3):368-371, Arnaout, M. A. et al., 1988, “Molecular cloning of the alpha subunit of human and guinea pig leukocyte adhesion glycoprotein Mol: chromosomal localization and homology to the alpha subunits of integrins,” *Proc. Natl. Acad. Sci. U.S.A.* 85 (8):2776-2780, and the amino acid sequence of ITGAM (identified by accession no. NP_000623) is disclosed in, e.g., Micklem, K. J. et al., 1985, “Isolation of complement-fragment-iC3b-binding proteins by affinity chromatography. The identification of p150,95 as an iC3b-binding protein,” *Biochem. J.* 231 (1):233-236, Pierce, M. W. et al., 1986, “N-terminal sequence of human leukocyte glycoprotein Mol:conservation across species and homology to platelet IIb/IIIa,” *Biochim. Biophys. Acta* 874 (3):368-371, Arnaout, M. A. et al., 1988, “Molecular cloning of the alpha subunit of human and guinea pig leukocyte adhesion glycoprotein Mol: chromosomal localization and homology to the alpha subunits of integrins,” *Proc. Natl. Acad. Sci. U.S.A.* 85 (8):2776-2780, each of which is incorporated by reference herein in its entirety.

[0399] The nucleotide sequence of JAK2 (identified by accession no. NM_004972) is disclosed in, e.g., Wilks, A. F. et al., 1991, “Two novel protein-tyrosine kinases, each with a second phosphotransferase-related catalytic domain, define a new class of protein kinase,” *Mol. Cell. Biol.* 11 (4):2057-2065, Pritchard, M. A. et al., 1992, “Two members of the JAK family of protein tyrosine kinases map to chromosomes 1p31.3 and 9p24,” *Mamm. Genome* 3 (1):36-38, Witthuhn, B. A. et al., 1993, “JAK2 associates with the erythropoietin receptor and is tyrosine phosphorylated and activated following stimulation with erythropoietin,” *Cell* 74 (2):227-236,

and the amino acid sequence of JAK2 (identified by accession no. NP_004963) is disclosed in, e.g., Wilks, A. F. et al., 1991, “Two novel protein-tyrosine kinases, each with a second phosphotransferase-related catalytic domain, define a new class of protein kinase,” *Mol. Cell. Biol.* 11 (4):2057-2065, Pritchard, M. A. et al., 1992, “Two members of the JAK family of protein tyrosine kinases map to chromosomes 1p31.3 and 9p24,” *Mamm. Genome* 3 (1):36-38, Witthuhn, B. A. et al., 1993, “JAK2 associates with the erythropoietin receptor and is tyrosine phosphorylated and activated following stimulation with erythropoietin,” *Cell* 74 (2):227-236, each of which is incorporated by reference herein in its entirety.

[0400] The nucleotide sequence of LDLR (identified by accession no. NM_000527) is disclosed in, e.g., Brown, M. S. et al., 1979, “Receptor-mediated endocytosis: insights from the lipoprotein receptor system,” *Proc. Natl. Acad. Sci. U.S.A.* 76 (7):3330-3337, Goldstein, J. L. et al., 1982, “Receptor-mediated endocytosis and the cellular uptake of low density lipoprotein,” *Ciba Found. Symp.* 92, 77-95, Tolleshaug H. et al., 1983, “The LDL receptor locus in familial hypercholesterolemia: multiple mutations disrupt transport and processing of a membrane receptor,” *Cell* 32 (3):941-951, and the amino acid sequence of LDLR (identified by accession no. NP_000518) is disclosed in, e.g., Brown, M. S. et al., 1979, “Receptor-mediated endocytosis: insights from the lipoprotein receptor system,” *Proc. Natl. Acad. Sci. U.S.A.* 76 (7):3330-3337, Goldstein, J. L. et al., 1982, “Receptor-mediated endocytosis and the cellular uptake of low density lipoprotein,” *Ciba Found. Symp.* 92, 77-95, Tolleshaug, H. et al., 1983, “The LDL receptor locus in familial hypercholesterolemia: multiple mutations disrupt transport and processing of a membrane receptor,” *Cell* 32 (3):941-951, each of which is incorporated by reference herein in its entirety.

[0401] The nucleotide sequence of LY96 (identified by accession no. NM_015364) is disclosed in, e.g., Shimazu, R. et al., 1999, “MD-2, a molecule that confers lipopolysaccharide responsiveness on Toll-like receptor 4,” *J. Exp. Med.* 189 (11):1777-1782, Kato, K. et al., 2000, “ESOP-1, a secreted protein expressed in the hematopoietic, nervous, and reproductive systems of embryonic and adult mice,” *Blood* 96 (1):362-364, Dziarski, R. et al., 2001, “MD-2 enables Toll-like receptor 2 (TLR2)-mediated responses to lipopolysaccharide and enhances TLR2-mediated responses to Gram-positive and Gram-negative bacteria and their cell wall components,” *J. Immunol.* 166 (3):1938-1944, and the amino acid sequence of LY96 (identified by accession no. NP_056179) is disclosed in, e.g., Shimazu, R. et al., 1999, “MD-2, a molecule that confers lipopolysaccharide responsiveness on Toll-like receptor 4,” *J. Exp. Med.* 189 (11):1777-1782, Kato, K. et al., 2000, “ESOP-1, a secreted protein expressed in the hematopoietic, nervous, and reproductive systems of embryonic and adult mice,” *Blood* 96 (1):362-364, Dziarski, R. et al., 2001, “MD-2 enables Toll-like receptor 2 (TLR2)-mediated responses to lipopolysaccharide and enhances TLR2-mediated responses to Gram-positive and Gram-negative bacteria and their cell wall components,” *J. Immunol.* 166 (3):1938-1944, each of which is incorporated by reference herein in its entirety.

[0402] The nucleotide sequence of MAP2K6 (identified by accession nos. NM_002758, NM_031988) is disclosed in, e.g., Han, J. et al., 1996, “Characterization of the structure and function of a novel MAP kinase kinase (MKK6),” *J. Biol. Chem.* 271 (6):2886-2891, Raingeaud, J. et al., 1996,

"MKK3- and MKK6-regulated gene expression is mediated by the p38 mitogen-activated protein kinase signal transduction pathway," *Mol. Cell. Biol.* 16 (3), 1247-1255, Stein, B. et al., 1996, "Cloning and characterization of MEK6, a novel member of the mitogen-activated protein kinase cascade," *J. Biol. Chem.* 271 (19): 11427-11433, and the amino acid sequence of MAP2K6 (identified by accession nos. NP_002749, NP_114365) is disclosed in, e.g., Han, J. et al., 1996, "Characterization of the structure and function of a novel MAP kinase kinase (MKK6), *J. Biol. Chem.* 271 (6): 2886-2891, Raingeaud, J. et al., 1996, "MKK3- and MKK6-regulated gene expression is mediated by the p38 mitogen-activated protein kinase signal transduction pathway," *Mol. Cell. Biol.* 16 (3), 1247-1255, Stein, B. et al., 1996, "Cloning and characterization of MEK6, a novel member of the mitogen-activated protein kinase cascade," *J. Biol. Chem.* 271 (19): 11427-11433, each of which is incorporated by reference herein in its entirety.

[0403] The nucleotide sequence of MAPK14 (identified by accession nos. NM_001315, NM_139012, NM_139013, NM_139014) is disclosed in, e.g., Zhukov-Verezhnikov, N. N. et al., 1976, "Study of the heterogenetic antigens in vaccinal preparations of *V. cholerae*," *Biochem. Biophys. Res. Commun.* 82 (8):961-962, Schultz, S. J. et al., 1993, Identification of 21 novel human protein kinases, including 3 Members of a family related to the cell cycle regulator nimA of *Aspergillus nidulans*," *Cell Growth Differ.* 4 (10):821-830, Lee, J. C. et al., 1994, "A protein kinase involved in the regulation of inflammatory cytokine biosynthesis," *Nature* 372 (6508):739-746, and the amino acid sequence of MAPK14 (identified by accession nos. NP_001306, NP_620581, IIP_620582, NP_620583) is disclosed in, e.g., Zhukov-Verezhnikov, N. N. et al., 1976, "Study of the heterogenetic antigens in vaccinal preparations of *V. cholerae*," *Biochem. Biophys. Res. Commun.* 82 (8):961-962, Schultz, S. J. et al., 1993, Identification of 21 novel human protein kinases, including 3 members of a family related to the cell cycle regulator nimA of *Aspergillus nidulans*," *Cell Growth Differ.* 4 (10):821-830, Lee, J. C. et al., 1994, "A protein kinase involved in the regulation of inflammatory cytokine biosynthesis," *Nature* 372 (6508):739-746, each of which is incorporated by reference herein in its entirety.

[0404] The nucleotide sequence of Monocyte Chemoattractant Protein 1 (MCP1) (identified by accession nos. AF493698 and AF493697) is disclosed in, e.g., Shanmugasundaram et al., 2002, Virology II, National Institute of Immunology, Aruna Asag Ali Marg, J.N.U. Campus, New Delhi 110 067, India, and the amino acid sequence of MCP1 (identified by accession no. AAQ75526) is disclosed in, e.g., Nyquist et al., 2003, direct submission, Medicine, Inova Fairfax, 3300 Gallows Road, Falls Church, Va. 22402-3300, each of which is incorporated by reference herein in its entirety.

[0405] The nucleotide sequence of MKNK1 (identified by accession nos. NM_003684, NM_198973) is disclosed in, e.g., Fukunaga et al., 1997, "MNK1, a new MAP kinase-activated protein kinase, isolated by a novel expression screening method for identifying protein kinase substrates," *EMBO J.* 16: 1921-1933; Pyronnet et al., 1999, "Human eukaryotic translation initiation factor 4G (eIF4G) recruits mnkl to phosphorylate eIF4E," *EMBO J.* 18: 270-279; Cuesta et al., 2000, "Chaperone hsp27 inhibits translation during heat shock by binding eIF4G and facilitating dissociation of cap-initiation complexes," *Genes Dev.* 14: 1460-1470, and the amino acid sequence of MKNK1 (identified by accession

nos. NP_003675, NP_945324) is disclosed in, e.g., Fukunaga et al., 1997, "MNK1, a new MAP kinase-activated protein kinase, isolated by a novel expression screening method for identifying protein kinase substrates," *EMBO J.* 16: 1921-1933, Pyronnet et al., 1999, "Human eukaryotic translation initiation factor 4G (eIF4G) recruits mnkl to phosphorylate eIF4E," *EMBO J.* 18: 270-279, Cuesta et al., 2000, "Chaperone hsp27 inhibits translation during heat shock by binding eIF4G and facilitating dissociation of cap-initiation complexes," *Genes Dev.* 14: 1460-1470, each of which is incorporated by reference herein in its entirety.

[0406] The nucleotide sequence of MMP9 (identified by accession no. NM_004994) is disclosed in, e.g., Wilhelm et al., 1989, "SV40-transformed human lung fibroblasts secrete a 92-kDa type IV collagenase which is identical to that secreted by normal human macrophages," *J. Biol. Chem.* 264: 17213-17221, Huhtala et al., 1990, "Completion of the primary structure of the human type IV collagenase preproenzyme and assignment of the gene (CLG4) to the q21 region of chromosome 16," *Genomics* 6: 554-559, Collier et al., 1991, "On the structure and chromosome location of the 72- and 92-kDa human type IV collagenase genes," *Genomics* 9: 429-434, and the amino acid sequence of MMP9 (identified by accession no. NP_004985) is disclosed in, e.g., Wilhelm et al., 1989, "SV40-transformed human lung fibroblasts secrete a 92-kDa type IV collagenase which is identical to that secreted by normal human macrophages," *J. Biol. Chem.* 264: 17213-17221, Huhtala et al., 1990, "Completion of the primary structure of the human type IV collagenase preproenzyme and assignment of the gene (CLG4) to the q21 region of chromosome 16," *Genomics* 6: 554-559, Collier et al., 1991, "On the structure and chromosome location of the 72- and 92-kDa human type IV collagenase genes," *Genomics* 9: 429-434, each of which is incorporated by reference herein in its entirety.

[0407] The nucleotide sequence of NCR I (identified by accession no. NM_004829) is disclosed in, e.g., Sivori et al., 1997, "p46, a novel natural killer cell-specific surface molecule that mediates cell activation," *J. Exp. Med.* 186:1129-1136, Vitale, M. et al., NKp44, 1998, "NKp44, a novel triggering surface molecule specifically expressed by activated natural killer cells, is involved in non-major histocompatibility complex-restricted tumor cell lysis," *J. Exp. Med.* 187: 2065-2072, Pessino et al., 1998, "Molecular cloning of NKp46: a novel member of the immunoglobulin superfamily involved in triggering of natural cytotoxicity," *J. Exp. Med.* 188: 953-960, and the amino acid sequence of NCR1 (identified by accession no. NP_004820) is disclosed in, e.g., Sivori et al., 1997, "p46, a novel natural killer cell-specific surface molecule that mediates cell activation," *J. Exp. Med.* 186:1129-1136, Vitale et al., NKp44, 1998, "NKp44, a novel triggering surface molecule specifically expressed by activated natural killer cells, is involved in non-major histocompatibility complex-restricted tumor cell lysis," *J. Exp. Med.* 187: 2065-2072, Pessino et al., 1998, "Molecular cloning of NKp46: a novel member of the immunoglobulin superfamily involved in triggering of natural cytotoxicity," *J. Exp. Med.* 188: 953-96, each of which is incorporated by reference herein in its entirety.

[0408] The nucleotide sequence of OSM (identified by accession no. NM_020530) is disclosed in, e.g., Zarling et al., 1986, "Oncostatin M: a growth regulator produced by differentiated histiocytic lymphoma cells," *Proc. Natl. Acad. Sci. U.S.A.* 83 (24):9739-9743, Malik et al., 1989, "Molecular cloning, sequence analysis, and functional expression of a novel growth regulator, oncostatin M," *Mol. Cell. Biol.* 9 (7):2847-2853, Linsley, P. S. et al., 1990, "Cleavage of a

hydrophilic C-terminal domain increases growth-inhibitory activity of oncostatin M," *Mol. Cell. Biol.* 10 (5):1882-1890, and the amino acid sequence of OSM (identified by accession no. NP_065391) is disclosed in, e.g., Zarling, J. M. et al., 1986, "Oncostatin M: a growth regulator produced by differentiated histiocytic lymphoma cells," *Proc. Natl. Acad. Sci. U.S.A.* 83 (24):9739-9743, Malik, N. et al., 1989, "Molecular cloning, sequence analysis, and functional expression of a novel growth regulator, oncostatin M," *Mol. Cell. Biol.* 9 (7):2847-2853, Linsley, P. S. et al., 1990, "Cleavage of a hydrophilic C-terminal domain increases growth-inhibitory activity of oncostatin M," *Mol. Cell. Biol.* 10 (5):1882-1890, each of which is incorporated by reference herein in its entirety.

[0409] The nucleotide sequence of PFKFB3 (identified by accession no. NM_004566) is disclosed in, e.g., Sakai, A. et al., 1996, "Cloning of cDNA encoding for a novel isozyme of fructose 6-phosphate, 2-kinase/fructose 2,6-bisphosphatase from human placenta," *J. Biochem.* 119 (3):506-511, Hamilton, J. A. et al., 1997, "Identification of PRG1, a novel progesterin-responsive gene with sequence homology to 6-phosphofructo-2-kinase/fructose-2,6-bisphosphatase," *Mol. Endocrinol.* 11 (4):490-502, Nicholl, J. et al., "The third human isoform of 6-phosphofructo-2-kinase/fructose-2,6-bisphosphatase (PFKFB3) map position 10p14-p15, Chromosome Res. 5 (2):150, and the amino acid sequence of PFKFB3 (identified by accession no. NP_004557) is disclosed in, e.g., Sakai, A. et al., 1996, "Cloning of cDNA encoding for a novel isozyme of fructose 6-phosphate, 2-kinase/fructose 2,6-bisphosphatase from human placenta," *J. Biochem.* 119 (3):506-511, Hamilton, J. A. et al., 1997, "Identification of PRG1, a novel progesterin-responsive gene with sequence homology to 6-phosphofructo-2-kinase/fructose-2,6-bisphosphatase," *Mol. Endocrinol.* 11 (4):490-502, Nicholl, J. et al., "The third human isoform of 6-phosphofructo-2-kinase/fructose-2,6-bisphosphatase (PFKFB3) map position 10p14-p15, Chromosome Res. 5 (2):150, each of which is incorporated by reference herein in its entirety.

[0410] The nucleotide sequence of PRV1 (identified by accession no. NM_020406) is disclosed in, e.g., Lalezari, P. et al., 1971, "NB1, a new neutrophil-specific antigen involved in the pathogenesis of neonatal neutropenia," *J. Clin. Invest.* 50 (5):1108-1115, Goldschmeding, R. et al., 1992, "Further characterization of the NB 1 antigen as a variably expressed 56-62 kD GPI-linked glycoprotein of plasma membranes and specific granules of neutrophils," *Br. J. Haematol.* 81 (3):336-345, Stroncek, D. F. et al., "Neutrophil-specific antigen NB1 inhibits neutrophil-endothelial cell interactions," *J. Lab. Clin. Med.* 123 (2):247-255, and the amino acid sequence of PRV1 (identified by accession no. NP_065139) is disclosed in, e.g., Lalezari, P. et al., 1971, "NB1, a new neutrophil-specific antigen involved in the pathogenesis of neonatal neutropenia," *J. Clin. Invest.* 50 (5):1108-1115, Goldschmeding, R. et al., 1992, "Further characterization of the NB1 antigen as a variably expressed 56-62 kD GPI-linked glycoprotein of plasma membranes and specific granules of neutrophils," *Br. J. Haematol.* 81 (3):336-345, Stroncek, D. F. et al., "Neutrophil-specific antigen NB1 inhibits neutrophil-endothelial cell interactions," *J. Lab. Clin. Med.* 123 (2):247-255, each of which is incorporated by reference herein in its entirety.

[0411] The nucleotide sequence of PSTPIP2 (identified by accession no. NM_024430) is disclosed in, e.g., Hillier, L. D. et al., 1996, "Generation and analysis of 280,000 human expressed sequence tags," *Genome Res.* 6 (9):807-828, Wu, Y.

et al., 1998, "PSTPIP 2, a second tyrosine phosphorylated, cytoskeletal-associated protein that binds a PEST-type protein-tyrosine phosphatase," *J. Biol. Chem.* 273 (46):30487-30496, Yeung, Y. G. et al., 1998, "A novel macrophage actin-associated protein (MAYP) is tyrosine-phosphorylated following colony stimulating factor-1 stimulation," *J. Biol. Chem.* 273 (46):30638-30642, and the amino acid sequence of PSTPIP2 (identified by accession no. NP_077748) is disclosed in, e.g., Hillier, L. D. et al., 1996, "Generation and analysis of 280,000 human expressed sequence tags," *Genome Res.* 6 (9):807-828, Wu, Y. et al., 1998, "PSTPIP 2, a second tyrosine phosphorylated, cytoskeletal-associated protein that binds a PEST-type protein-tyrosine phosphatase," *J. Biol. Chem.* 273 (46):30487-30496, Yeung, Y. G. et al., 1998, "A novel macrophage actin-associated protein (MAYP) is tyrosine-phosphorylated following colony stimulating factor-1 stimulation," *J. Biol. Chem.* 273 (46):30638-30642, each of which is incorporated by reference herein in its entirety.

[0412] The nucleotide sequence of SOCS3 (identified by accession no. NM_003955) is disclosed in, e.g., Minamoto, S. et al., 1997, "Cloning and functional analysis of new members of STAT induced STAT inhibitor (SSI) family: SSI-2 and SSI-3," *Biochem. Biophys. Res. Commun.* 237 (1):79-83, Masuhara, M. et al., 1997, "Cloning and characterization of novel CIS family genes," *Biochem. Biophys. Res. Commun.* 239 (2):439-446, Zhang, J. G. et al., 1999, "The conserved SOCS box motif in suppressors of cytokine signaling binds to elongins B and C and may couple bound proteins to proteasomal degradation," *Proc. Natl. Acad. Sci. U.S.A.* 96 (5):2071-2076, and the amino acid sequence of SOCS3 (identified by accession no. NP_003946) is disclosed in, e.g., Minamoto, S. et al., 1997, "Cloning and functional analysis of new members of STAT induced STAT inhibitor (SSI) family: SSI-2 and SSI-3," *Biochem. Biophys. Res. Commun.* 237 (1):79-83, Masuhara, M. et al., 1997, "Cloning and characterization of novel CIS family genes," *Biochem. Biophys. Res. Commun.* 239 (2):439-446, Zhang, J. G. et al., 1999, "The conserved SOCS box motif in suppressors of cytokine signaling binds to elongins B and C and may couple bound proteins to proteasomal degradation," *Proc. Natl. Acad. Sci. U.S.A.* 96 (5):2071-2076, each of which is incorporated by reference herein in its entirety.

[0413] The nucleotide sequence of SOD2 (identified by accession no. NM_000636) is disclosed in, e.g., Smith, M. et al., 1978, "Regional localization of HLA, MES, and SODM on chromosome 6," *Cytogenet. Cell Genet.* 22 (1-6):428-433, Beck, Y. et al., 1987, "Human Mn superoxide dismutase cDNA sequence," *Nucleic Acids Res.* 15 (21):9076, Ho, Y. S. et al., 1988, "Isolation and characterization of complementary DNAs encoding human manganese-containing superoxide dismutase," *FEBS Lett.* 229 (2):256-260, and the amino acid sequence of SOD2 (identified by accession no. NP_000627) is disclosed in, e.g., Smith, M. et al., 1978, "Regional localization of HLA, MES, and SODM on chromosome 6," *Cytogenet. Cell Genet.* 22 (1-6):428-433, Beck, Y. et al., 1987, "Human Mn superoxide dismutase cDNA sequence," *Nucleic Acids Res.* 15 (21):9076, Ho, Y. S. et al., 1988, "Isolation and characterization of complementary DNAs encoding human manganese-containing superoxide dismutase," *FEBS Lett.* 229 (2):256-260, each of which is incorporated by reference herein in its entirety.

[0414] The nucleotide sequence of TDRD9 (identified by accession no. NM_153046) is disclosed in, e.g., Isogai et al.,

2003, "Homo sapiens cDNA FLJ43990 fis, clone TESTI4019566, weakly similar to Dosage compensation regulator," unpublished, and the amino acid sequence of TDRD9 (identified by accession no. NP_694591) is disclosed in, e.g., Isogai et al., 2003, "Homo sapiens cDNA FLJ43990 fis, clone TESTI4019566, weakly similar to Dosage compensation regulator," unpublished, each of which is incorporated by reference herein in its entirety.

[0415] The nucleotide sequence of TGFB1 (identified by accession no. NM_000358) is disclosed in, e.g., Skonier et al., 1992, "cDNA cloning and sequence analysis of beta ig-h3, a novel gene induced in a human adenocarcinoma cell line after treatment with transforming growth factor-beta," DNA Cell Biol. 11 (7):511-522, Stone et al., 1994, "Three autosomal dominant corneal dystrophies map to chromosome 5q," Nat. Genet. 6 (1):47-51, Skonier et al., 1994, "beta ig-h3: a transforming growth factor-beta-responsive gene encoding a secreted protein that inhibits cell attachment in vitro and suppresses the growth of CHO cells in nude mice," DNA Cell Biol. 13 (6):571-584, and the amino acid sequence of TGFB1 (identified by accession no. NP_000349) is disclosed in, e.g., Skonier et al., 1992, "cDNA cloning and sequence analysis of beta ig-h3, a novel gene induced in a human adenocarcinoma cell line after treatment with transforming growth factor-beta," DNA Cell Biol. 11 (7):511-522; Stone et al., 1994, "Three autosomal dominant corneal dystrophies map to chromosome 5q," Nat. Genet. 6 (1):47-51; Skonier et al., 1994, "beta ig-h3: a transforming growth factor-beta-responsive gene encoding a secreted protein that inhibits cell attachment in vitro and suppresses the growth of CHO cells in nude mice," DNA Cell Biol. 13: 571-584, each of which is incorporated by reference herein in its entirety.

[0416] The nucleotide sequence of TIFA (identified by accession no. NM_052864) is disclosed in, e.g., Kanamori, M. et al., 2002, "T2BP, a novel TRAF2 binding protein, can activate NF-kappaB and AP-1 without TNF stimulation," Biochem. Biophys. Res. Commun. 290 (3):1108-1113, Takatsuna, H. et al., 2003, "Identification of TIFA as an adapter protein that links tumor necrosis factor receptor-associated factor 6 (TRAF6) to interleukin-1 (IL-1) receptor-associated kinase-1 (IRAK-1) in IL-1 receptor signaling," J. Biol. Chem. 278 (14):12144-12150, Matsuda et al., 2003, "Large-scale identification and characterization of human genes that activate NF-kappaB and MAPK signaling pathways," Oncogene 22 (21):3307-3318, and the amino acid sequence of TIFA (identified by accession no. NP_443096) is disclosed in, e.g., Kanamori et al., 2002, "T2BP, a novel TRAF2 binding protein, can activate NF-kappaB and AP-1 without TNF stimulation," Biochem. Biophys. Res. Commun. 290:1108-1113, Takatsuna et al., 2003, "Identification of TIFA as an adapter protein that links tumor necrosis factor receptor-associated factor 6 (TRAF6) to interleukin-1 (IL-1) receptor-associated kinase-1 (IRAK-1) in IL-1 receptor signaling," J. Biol. Chem. 278 (14):12144-12150, Matsuda et al., 2003, "Large-scale identification and characterization of human genes that activate NF-kappaB and MAPK signaling pathways," Oncogene 22 (20):3307-3318, each of which is incorporated by reference herein in its entirety.

[0417] The nucleotide sequence of Tissue Inhibitor of Metalloproteinase 1 (TIMP1) (identified by accession no. NM_003254) is disclosed in, e.g., Domeij et al., 2005, "ell expression of MMP-1 and TIMP-1 in co-cultures of human gingival fibroblasts and monocytes: the involvement of ICAM-1," Biochem. Biophys. Res. Commun. 338, 1825-

1833; Zureik et al., "Serum tissue inhibitors of metalloproteinases 1 (TIMP-1) and carotid atherosclerosis and aortic arterial stiffness", J. Hypertens. 23, 2263-2268; Crombez, 2005, "High level production of secreted proteins: example of the human tissue inhibitor of metalloproteinases 1", Biochem. Biophys. Res. Commun. 337, 908-915 and the amino acid sequence of TIMP1 (identified by accession no. AAA75558) is disclosed in, e.g., Hardcastle et al., 1997, "Genomic organization of the human TIMP-1 gene. Investigation of a causative role in the pathogenesis of X-linked retinitis pigmentosa," Invest. Ophthalmol. Vis. Sci. 38, 1893-1896, which is incorporated by reference herein in its entirety.

[0418] The nucleotide sequence of TLR4 (identified by accession no. AH009665) is disclosed in, e.g., Arbour, N. C. et al., 1999, Direct Submission, Medicine, University of Iowa, 2182 Med Labs, Iowa City, Iowa 52242, USA, Arbour, N. C. et al., A Genetic Basis for a Blunted Response to Endotoxin in Humans, Arbour, N. C. et al., unpublished, "A Genetic Basis for a Blunted Response to Endotoxin in Humans", and the amino acid sequence of TLR4 (identified by accession no. AAF05316) is disclosed in, e.g., Beutler, 1999, Direct Submission, Department of Internal Medicine, University of Texas Southwestern Medical Center and the Howard Hughes Medical Institute, 5323 Harry Hines Boulevard, Dallas, Tex. 75235-9050, USA, Smirnova, I. et al., 2000, "Phylogenetic variation and polymorphism at the toll-like receptor 4 locus (TLR4)," Genome Biol. 1, res. 002.1-002.10, each of which is incorporated by reference herein in its entirety.

[0419] The nucleotide sequence of TNFRSF6 (identified by accession no. NM_152877) is disclosed in, e.g., Oehm, A. et al., 1992, "Purification and molecular cloning of the APO-1 cell surface antigen, a member of the tumor necrosis factor/nerve growth factor receptor superfamily. Sequence identity with the Fas antigen," J. Biol. Chem. 267 (15):10709-10715, Inazawa, J. et al., 1992, "Assignment of the human Fas antigen gene (Fas) to 10q24.1," Genomics 14 (3):821-822, Cheng, J. et al., 1994, "Protection from Fas-mediated apoptosis by a soluble form of the Fas molecule," Science 263 (5154):1759-1762, and the amino acid sequence of TNFRSF6 (identified by accession no. NP_000034) is disclosed in, e.g., Oehm, A. et al., 1992, "Purification and molecular cloning of the APO-1 cell surface antigen, a member of the tumor necrosis factor/nerve growth factor receptor superfamily. Sequence identity with the Fas antigen," J. Biol. Chem. 267 (15):10709-10715, Inazawa, J. et al., 1992, "Assignment of the human Fas antigen gene (Fas) to 10q24.1," Genomics 14 (3):821-822, Cheng, J. et al., 1994, "Protection from Fas-mediated apoptosis by a soluble form of the Fas molecule," Science 263 (5154):1759-1762, each of which is incorporated by reference herein in its entirety.

[0420] The nucleotide sequence of TNFSF10 (identified by accession no. NM_003810) is disclosed in, e.g., Wiley, S. R. et al., 1995, "Identification and characterization of a new member of the TNF family that induces apoptosis," Immunity 3 (6):673-682, Pitti, R. M. et al., 1996, "Induction of apoptosis by Apo-2 ligand, a new member of the tumor necrosis factor cytokine family," J. Biol. Chem. 271 (22):12687-12690, Pan, G. et al., 1997, "The receptor for the cytotoxic ligand TRAIL," Science 276 (5309):111-113, and the amino acid sequence of TNFSF10 (identified by accession no. NP_003801) is disclosed in, e.g., Wiley, S. R. et al., 1995, "Identification and characterization of a new member of the TNF family that induces apoptosis," Immunity 3 (6):673-682,

Pitti, R. M. et al., 1996, "Induction of apoptosis by Apo-2 ligand, a new member of the tumor necrosis factor cytokine family," *J. Biol. Chem.* 271 (22):12687-12690, Pan, G. et al., 1997, "The receptor for the cytotoxic ligand TRAIL," *Science* 276 (5309):111-113, each of which is incorporated by reference herein in its entirety.

[0421] The nucleotide sequence of TNFSF13B (identified by accession no. NM_006573) is disclosed in, e.g., Shu, H. B. et al., 1999, "TALL-1 is a novel member of the TNF family that is down-regulated by mitogens," *J. Leukoc. Biol.* 65 (5): 680-683, Mukhopadhyay, A. et al., 1999, "Identification and characterization of a novel cytokine, THANK, a TNF homologue that activates apoptosis, nuclear factor-kappaB, and c-Jun NH₂-terminal kinase," *J. Biol. Chem.* 274 (23):15978-15981, Schneider, P. et al., 1999, "BAFF, a novel ligand of the tumor necrosis factor family, stimulates B cell growth," *J. Exp. Med.* 189 (11):1747-1756, and the amino acid sequence of TNFSF13B (identified by accession no. NP_006564) is disclosed in, e.g., Shu, H. B. et al., 1999, "TALL-1 is a novel member of the TNF family that is down-regulated by mitogens," *J. Leukoc. Biol.* 65 (5): 680-683, Mukhopadhyay, A. et al., 1999, "Identification and characterization of a novel cytokine, THANK, a TNF homologue that activates apoptosis, nuclear factor-kappaB, and c-Jun NH₂-terminal kinase," *J. Biol. Chem.* 274 (23):15978-15981, Schneider, P. et al., 1999, "BAFF, a novel ligand of the tumor necrosis factor family, stimulates B cell growth," *J. Exp. Med.* 189 (11): 1747-1756, each of which is incorporated by reference herein in its entirety.

[0422] The nucleotide sequence of VNN1 (identified by accession no. NM_004666) is disclosed in, e.g., Aurrand-Lions, M. et al., 1996, "Vanin-1, a novel GPI-linked perivascular molecule involved in thymus homing," *Immunity* 5 (5):391-405, Galland, F. et al., 1998, "Two human genes related to murine vanin-1 are located on the long arm of human chromosome 6," *Genomics* 53 (2):203-213, Maras, B. et al., 1999, "Is pantetheinase the actual identity of mouse and human vanin-1 proteins?," *FEBS Lett.* 461 (3):149-152, and the amino acid sequence of VNN1 (identified by accession no. NP_004657) is disclosed in, e.g., Aurrand-Lions, M. et al., 1996, "Vanin-1, a novel GPI-linked perivascular molecule involved in thymus homing," *Immunity* 5 (5):391-405, Galland, F. et al., 1998, "Two human genes related to murine vanin-1 are located on the long arm of human chromosome 6," *Genomics* 53 (2):203-213, Maras, B. et al., 1999, "Is pantetheinase the actual identity of mouse and human vanin-1 proteins?," *FEBS Lett.* 461 (3):149-152, each of which is incorporated by reference herein in its entirety.

5.11.2 Exemplary Combinations of Biomarkers in Accordance with Embodiments of the Invention

[0423] In some embodiments, the methods or kits respectively described or referenced in Section 5.2 and Section 5.3 use at least 2, 3, 4, 5, 6, 7, 8, 9, 10, 11, 12, 13, 14, 15, 16, 17, 18, 19, 20, 21, 22, 23, 24, 25, 30, 35, 40, 45, 50, or more biomarkers selected from Table I regardless of whether each such biomarker has an "N" designation or a "P" designation in Table I. In some nonlimiting exemplary embodiments, between 2 and 53, between 3 and 40, between 4 and 30, or between 5 and 20 such biomarkers are used.

[0424] Nucleic acid based kits and methods. In some embodiments, the methods or kits respectively described or referenced in Section 5.2 and Section 5.3 use at least 2, 3, 4, 5, 6, 7, 8, 9, 10, 11, 12, 13, 14, 15, 16, 17, 18, 19, 20, 21, 22,

23, 24, 25, 30, 35, 40, or more biomarkers selected from Table I. Typically, in these embodiments, each biomarker is a nucleic acid (e.g., DNA, such as cDNA or amplified DNA, or RNA, such as mRNA), or a discriminating molecule or discriminating fragment of a nucleic acid. In some nonlimiting exemplary embodiments, between 2 and 44, between 3 and 35, between 4 and 25, or between 5 and 20 such biomarkers are used.

[0425] Protein or peptide based kits and methods. In some embodiments, the methods or kits respectively described or referenced in Section 5.2 and Section 5.3 use at least 2, 3, 4, 5, 6, 7, 8, 9, or 10 of the biomarkers selected from Table K. Typically, such biomarkers are peptide-based (e.g., a peptide, a full length protein, etc.), or a discriminating molecule or discriminating fragment of the foregoing. In some embodiments, the biomarkers in the kit are specific antibodies to two or more of the biomarkers listed in Table K. In some nonlimiting exemplary embodiments, between 2 and 10, between 3 and 10, between 4 and 10, or between 5 and 10 such biomarkers are used.

[0426] Homogenous kits and methods. In some embodiments, each of the biomarkers in the methods or kits respectively described or referenced in Section 5.2 and Section 5.3 use at least two or more biomarkers selected from Table I where each biomarker used in such methods or kits is in the same physical form. In one example in accordance with such embodiments, each biomarker in a method or kit in accordance Section 5.2 and Section 5.3, respectively, is a biomarker selected from Table I and is a nucleic acid or a discriminating molecule of a nucleic acid in the method or kit. In another example in accordance with such embodiments, each biomarker in a method or kit in accordance Section 5.2 and Section 5.3, respectively, is a biomarker selected from Table I and is peptide-based (e.g., a peptide, a full length protein, etc.) or a discriminating molecule of the foregoing. In these embodiments, biomarkers are selected without regard as to whether they are designated "P" or "N" in Table I. Thus, a kit in accordance with these embodiments can include a biomarker in nucleic acid form, even when the biomarker is designated "P" on Table I. Correspondingly, a kit in accordance with this embodiment can include a biomarker in peptidic form, even when the biomarker is designated "N" on Table I.

[0427] Heterogeneous kits and methods. In some embodiments, each of the biomarkers in the methods and kits respectively described or referenced in Section 5.2 and Section 5.3 use at least two or more biomarkers selected from Table I where each such biomarker is in the same physical form that the biomarker was in when identified in Sections 6.11 through 6.13 below. In other words, if the biomarker has an "N" designation in Table I, a nucleic acid form of the biomarker is used in the methods and kits respectively described or referenced in Section 5.2 and 5.3 in accordance with this embodiment of the invention. If the biomarker has a "P" designation in Table I, a peptidic form of the biomarker is used in the methods and kits respectively described or referenced in Section 5.2 and 5.3 in accordance with this embodiment of the invention. Further, there is at least one biomarker used in such methods or kits that has an "N" designation in Table I and at least one biomarker that has a "P" designation. In such embodiments, biomarkers having an N designation in Table I are nucleic acids and biomarkers having a P designation in Table I are peptide-based or protein-based.

[0428] A non-limiting exemplary kit in accordance with such mixed embodiments use two biomarkers from among

the biomarkers listed in Table J, in nucleic acid form, and three biomarkers from among the biomarkers listed in Table K, in peptidic-based form. In some embodiments, the non-limiting methods and kits respectively described or referenced in Sections 5.2 and 5.3 use at least 2, 3, 4, 5, 6, 7, 8, 9, 10, 11, 12, 13, 14, 15, 16, 17, 18, 19, 20, 21, 22, 23, 24, 25, 30, 35, 40, or more biomarkers from Table J, in nucleic acid form, and 1, 2, 3, 4, 5, 6, 7, 8, 9, or 10 biomarkers from Table K in peptide-based or protein-based form.

[0429] Additional kits and methods. In some embodiments, each of the biomarkers in the methods and kits respectively described or referenced in Section 5.2 and Section 5.3 use at least one biomarkers selected from Table I and at least one different biomarker from Table 31. In some embodiments, each of the biomarkers in the methods and kits respectively described or referenced in Section 5.2 and Section 5.3 use at least 2, 3, 4, 5, 6, 7, 8, 9, or 10 biomarkers selected from Table I and at least 2, 3, 4, 5, 6, 7, 8, 9, or 10 different biomarkers from Table 31.

[0430] In some embodiments, each of the biomarkers in the methods and kits respectively described or referenced in Section 5.2 and Section 5.3 use at least one biomarker in, nucleic acid form, selected from Table J and at least one different biomarker from Table 31. In some embodiments, each of the biomarkers in the methods and kits respectively described or referenced in Section 5.2 and Section 5.3 use at least 2, 3, 4, 5, 6, 7, 8, 9, or 10 biomarkers selected from Table I, each in nucleic acid form, and at least 2, 3, 4, 5, 6, 7, 8, 9, or 10 different biomarkers from Table 31.

[0431] In some embodiments, each of the biomarkers in the methods and kits respectively described or referenced in Section 5.2 and Section 5.3 use at least one biomarker in, protein form, selected from Table K and at least one different biomarker from Table 31. In some embodiments, each of the biomarkers in the methods and kits respectively described or referenced in Section 5.2 and Section 5.3 use at least 2, 3, 4, 5, 6, 7, 8, 9, or 10 biomarkers selected from Table I, each in protein form, and at least 2, 3, 4, 5, 6, 7, 8, 9, or 10 different biomarkers from Table 31.

[0432] In some embodiments, each of the biomarkers in the methods and kits respectively described or referenced in Section 5.2 and Section 5.3 use at least one biomarker from among the biomarkers listed in Table J, in nucleic acid form, and at least one biomarkers from among the biomarkers listed in Table K, in protein form. In some embodiments, the non-limiting methods and kits respectively described or referenced in Sections 5.2 and 5.3 use at least 2, 3, 4, 5, 6, 7, 8, 9, 10, 11, 12, 13, 14, 15, 16, 17, 18, 19, 20, 21, 22, 23, 24, 25, 30, 35, 40, or more biomarkers from Table J, in nucleic acid form, and 1, 2, 3, 4, 5, 6, 7, 8, 9, or 10 biomarkers from Table K in protein form.

[0433] In some embodiments, any of the above-described combinations of biomarkers are used in methods or kits in accordance Section 5.2 and Section 5.3 with the exception that the IL-6, IL-8, MMP9, B2M, HLA-DRA, and MCP1 biomarkers are not used in such methods or kits. For example, in embodiments where certain monocytes are isolated from whole blood and tested, such biomarkers are not utilized, especially when such biomarkers are nucleic acids. In some embodiments, any of the above-described combinations of biomarkers are used in methods or kits in accordance Section 5.2 and Section 5.3 with the exception that the IL-6, IL-8, IL-10, and CRP protein biomarkers are not used in such methods or kits. In some embodiments, any of the above-

described combinations of biomarkers are used in methods or kits in accordance Section 5.2 and Section 5.3 with the exception that the IL-6, IL-8, IL-10, and CRP nucleic acid biomarkers are not used in such methods or kits. In some embodiments, any of the above-described combinations of biomarkers are used in methods or kits in accordance Section 5.2 and Section 5.3 with the exception that the IL-6 and MAPK biomarkers are not used in such methods or kits. In some embodiments, any of the above-described combinations of biomarkers are used in methods or kits in accordance Section 5.2 and Section 5.3 with the exception that the IL-6, IL-8, and IL-10 biomarkers are not used in such methods or kits. In some embodiments, any of the above-described combinations of biomarkers are used in methods or kits in accordance Section 5.2 and Section 5.3 with the exception that the CD86, IL-6, IL-8, IL-10, and CRP biomarkers are not used in such methods or kits. In some embodiments, any of the above-described combinations of biomarkers are used in methods or kits in accordance Section 5.2 and Section 5.3 with the exception that the IL-6 and IL-10 biomarkers are not used in such methods or kits. In some embodiments, any of the above-described combinations of biomarkers are used in methods or kits in accordance Section 5.2 and Section 5.3 with the exception that the IL-6 and CRP biomarkers are not used in such methods or kits. In some embodiments, any of the above-described combinations of biomarkers are used in methods or kits in accordance Section 5.2 and Section 5.3 with the exception that the CRP biomarker is not used in such methods or kits. In some embodiments, any of the above-described combinations of biomarkers are used in methods or kits in accordance Section 5.2 and Section 5.3 with the exception that the IL-8 biomarker is not used in such methods or kits. In some embodiments, any of the above-described combinations of biomarkers are used in methods or kits in accordance Section 5.2 and Section 5.3 with the exception that the B2M biomarker is not used in such methods or kits.

5.11.3 Exemplary Subcombinations of Biomarkers in Accordance with Embodiments of the Invention

[0434] In some embodiments, the methods or kits respectively described or referenced in Section 5.2 and Section 5.3 use any one biomarker set listed in Table L. The biomarker sets listed in Table L were identified in the computational experiments described in Section 6.14.1, below, in which 4600 random subcombinations of the biomarkers listed in Table J were tested. Table L, below, lists some of the biomarker sets that provided high accuracy scores against the validation population described in Section 6.14.1. Each row of Table L lists a single biomarker set that can be used in the methods and kits respectively referenced in Sections 5.2 and 5.3. In other words, each row of Table L describes a biomarker set that can be used to discriminate between sepsis and SIRS subjects (e.g., to determine whether a subject is likely to acquire sepsis). In some embodiments, nucleic acid forms of the biomarkers listed in a biomarker set in Table L are used in the methods and kits respectively referenced in Sections 5.2 and 5.3. In some embodiments, protein forms of the biomarkers listed in a biomarker set in Table L are used in the methods and kits respectively referenced in Sections 5.2 and 5.3. In some hybrid embodiments, some of the biomarkers in a biomarker set listed in Table L are in protein form and some of the biomarkers in the same biomarker set from Table L are in nucleic acid form in the methods and kits respectively referenced in Sections 5.2 and 5.3.

[0435] In some embodiments, a given biomarker set listed in Table L is used with the addition of one, two, three, four, five, six, seven, eight, or nine or more additional biomarkers listed in Table I that are not within the given set of biomarkers from Table L. In some embodiments, a given biomarker set listed in Table L is used with the addition of one, two, three,

four, five, six, seven, eight, or nine or more additional biomarkers from any one of Tables 1, 30, 31, 32, 33, 34, or 36 that are not within the given biomarker set from Table L. In Table L, accuracy, specificity, and sensitivity are described with reference to T₋₁₂ time point data described in Section 6.14.1, below.

TABLE L

Exemplary sets of biomarkers used in the methods or kits referenced in Sections 5.2 and 5.3			
BIOMARKER SET	ACCURACY	SPECIFICITY	SENSITIVITY
INSL3, BCL2A1, CD86	0.82	0.82	0.83
MAP2K6, INSL3, CD86	0.82	0.75	0.87
ARG2, MAP2K6, SOCS3	0.82	0.75	0.87
NCR1, GADD45A, OSM	0.81	0.77	0.85
GADD45B, TNFSF13B, PFKFB3	0.80	0.74	0.87
TLR4, FCGR1A, CSF1R	0.80	0.82	0.78
SOCS3, FCGR1A, PSTPIP2	0.80	0.79	0.81
TGFBI, MAP2K6, PSTPIP2	0.80	0.76	0.83
IFNGR1, JAK2, TNFRSF6, OSM	0.83	0.80	0.87
IRAK2, GADD45A, CD86, JAK2	0.83	0.86	0.81
GADD45A, PRV1, OSM, FCGR1A	0.83	0.80	0.86
IRAK4, CCL5, INSL3, CD86	0.83	0.76	0.90
VNN1, BCL2A1, GADD45B, FAD104	0.82	0.83	0.81
OSM, CD86, PRV1, BCL2A1	0.82	0.78	0.85
VNN1, SOCS3, CSF1R, FCGR1A	0.82	0.78	0.85
VNN1, CCL5, ANKRD22, OSM	0.82	0.77	0.86
LDLR, SOCS3, CD86, IL10alpha	0.81	0.78	0.85
TLR4, SOCS3, IRAK2, CSF1R	0.81	0.76	0.85
IL1RN, SOCS3, ARG2, LDLR	0.81	0.76	0.84
IL18R1, MAP2K6, TGFBI, OSM	0.80	0.86	0.75
FCGR1A, HLA-DRA, IL18R1, PSTPIP2	0.80	0.79	0.82
OSM, IL1RN, SOD2, SOCS3	0.80	0.78	0.82
NCR1, JAK2, TNFSF13B, FCGR1A	0.80	0.76	0.86
TIFA, VNN1, ANXA3, ITGAM	0.80	0.73	0.88
PFKFB3, IRAK2, CSF1R, CD86, PSTPIP2	0.88	0.83	0.91
PSTPIP2, FAD104, TIFA, CD86, LY96	0.84	0.85	0.84
IL1RN, IL10alpha, IFNGR1, OSM, MKNK1	0.83	0.78	0.89
IL18R1, CCL5, JAK2, SOCS3, SOD2	0.83	0.81	0.84
JAK2, MKNK1, TNFSF13B, PRV1, TNFSF10	0.83	0.81	0.84
MAP2K6, ARG2, OSM, ANKRD22, Gene_MMP9	0.83	0.8	0.85
SOCS3, IL1RN, ARG2, FCGR1A, CCL5	0.83	0.78	0.87
CCL5, INSL3, SOD2, TLR4, ARG2	0.83	0.78	0.87
FCGR1A, ARG2, CD86, MAPK14, TNFRSF6	0.82	0.83	0.82
INSL3, TLR4, SOCS3, CSF1R, FCGR1A	0.82	0.79	0.85
CEACAM1, TNFRSF6, MAPK14, IL10alpha, CSF1R	0.82	0.79	0.84
ANKRD22, CD86, CRTAP, OSM, PFKFB3	0.82	0.79	0.84
OSM, IL18R1, LDLR, GADD45B, MKNK1	0.82	0.76	0.86
CRTAP, SOCS3, PSTPIP2, TIFA, FAD104	0.81	0.82	0.81
PSTPIP2, ARG2, IL10alpha, TLR4, CSF1R	0.81	0.81	0.82
TIFA, PFKFB3, CSF1R, LDLR, Gene_MMP9	0.81	0.79	0.83
NCR1, PSTPIP2, GADD45A, LY96, MAPK14	0.81	0.77	0.86
ARG2, BCL2A1, NCR1, PSTPIP2, IL10alpha	0.81	0.82	0.8
PFKFB3, OSM, CSF1R, CD86, TIFA	0.81	0.81	0.81
IL10alpha, CD86, SOCS3, GADD45A, TGFBI	0.81	0.78	0.84
PSTPIP2, PFKFB3, INSL3, PRV1, IL1RN	0.81	0.78	0.85
ITGAM, PRV1, IL18R1, INSL3, JAK2	0.81	0.77	0.85
PSTPIP2, OSM, IL18R1, TNFSF13B, ITGAM	0.81	0.72	0.9
CD86, TIFA, CSF1R, FCGR1A, CRTAP	0.81	0.84	0.78
LY96, TGFBI, SOCS3, ANKRD22, MAPK14	0.81	0.83	0.79
IL1RN, SOD2, VNN1, OSM, TNFSF10	0.81	0.79	0.82
CRTAP, NCR1, OSM, PRV1, ANXA3	0.81	0.76	0.85
TDRD9, LY96, CEACAM1, OSM, NCR1	0.81	0.72	0.88
TGFBI, INSL3, GADD45A, LDLR, PSTPIP2	0.8	0.75	0.85
PFKFB3, IRAK2, CSF1R, CD86, PSTPIP2	0.88	0.83	0.91
MAP2K6, ARG2, CD86, PRV1, FAD104, MAPK14	0.85	0.86	0.84
ARG2, LY96, INSL3, MAP2K6, TNFSF10, NCR1	0.85	0.86	0.84
SOCS3, GADD45B, CSF1R, ARG2, PSTPIP2, OSM	0.85	0.83	0.86

TABLE L-continued

Exemplary sets of biomarkers used in the methods or kits referenced in Sections 5.2 and 5.3			
BIOMARKER SET	ACCURACY	SPECIFICITY	SENSISTIVITY
GADD45B, PFKFB3, PSTPIP2, FCGR1A, HLA-DRA, ARG2	0.85	0.81	0.88
TIFA, IL18R1, MAPK14, CD86, ARG2, TNFSF13B	0.84	0.8	0.88
FCGR1A, ARG2, GADD45B, IL10alpha, NCR1, LDLR	0.84	0.81	0.86
TGFBI, INSL3, IRAK4, GADD45B, SOCS3, CSF1R	0.84	0.8	0.87
SOCS3, CSF1R, CEACAM1, ARG2, IL10alpha, IFNGR1	0.83	0.82	0.85
TLR4, PFKFB3, ARG2, PRV1, LDLR, TNFSF13B	0.83	0.81	0.85
PSTPIP2, OSM, TLR4, INSL3, IRAK4, IL18R1	0.83	0.8	0.85
GADD45A, CCL5, FCGR1A, PSTPIP2, MAP2K6, IL1RN	0.82	0.83	0.82
OSM, FAD104, JAK2, CRTAP, TDRD9, TNFSF13B	0.82	0.79	0.85
FAD104, SOCS3, TNFSF13B, GADD45B, CRTAP, TGFBI	0.82	0.84	0.81
IL18R1, TNFRSF6, INSL3, CD86, ANXA3, PSTPIP2	0.82	0.79	0.84
HLA-DRA, INSL3, ARG2, CD86, CCL5, SOCS3	0.82	0.79	0.84
TNFRSF6, IL18R1, CD86, PFKFB3, IL10alpha, FAD104	0.81	0.82	0.81
FAD104, TGFBI, TDRD9, CD86, SOD2, ARG2	0.81	0.79	0.83
CD86, ARG2, GADD45A, TLR4, BCL2A1, GADD45B	0.81	0.79	0.83
SOD2, CEACAM1, OSM, GADD45A, PSTPIP2, IL10alpha	0.81	0.74	0.88
FCGR1A, CSF1R, NCR1, ANXA3, SOCS3, Gene_MMP9	0.81	0.81	0.8
TNFSF10, IL1RN, OSM, CSF1R, PSTPIP2, JAK2	0.81	0.78	0.83
CD86, VNN1, LDLR, IL1RN, MAP2K6, TDRD9	0.81	0.76	0.84
ARG2, OSM, CSF1R, ITGAM, CRTAP, SOCS3	0.81	0.76	0.85
ANXA3, CSF1R, CEACAM1, Gene_MMP9, CD86, OSM	0.8	0.8	0.81
LY96, VNN1, SOD2, TGFBI, ARG2, CSF1R	0.8	0.78	0.83
GADD45A, PSTPIP2, BCL2A1, ANKRD22, HLA-DRA, ANXA3	0.8	0.77	0.83
TGFBI, FCGR1A, ARG2, CD86, PFKFB3, BCL2A1, TNFRSF6	0.86	0.86	0.85
SOCS3, ITGAM, TDRD9, INSL3, PRV1, TGFBI, ARG2	0.84	0.81	0.87
MKMK1, GADD45B, IRAK2, TIFA, OSM, VNN1, PSTPIP2	0.83	0.81	0.85
SOCS3, PSTPIP2, TDRD9, IL10alpha, ARG2, CD86, CCL5	0.83	0.82	0.84
CSF1R, PSTPIP2, MAPK14, INSL3, IL18R1, JAK2, OSM	0.83	0.78	0.87
MKMK1, PSTPIP2, ARG2, LY96, ANKRD22, SOCS3, IRAK4	0.82	0.85	0.8
PSTPIP2, FAD104, TNFSF13B, ITGAM, BCL2A1, FCGR1A, ANXA3	0.82	0.83	0.82
SOCS3, IRAK2, IFNGR1, CD86, OSM, PSTPIP2, GADD45A	0.82	0.81	0.83
INSL3, NCR1, PSTPIP2, PFKFB3, ANKRD22, HLA-DRA, MKMK1	0.82	0.8	0.84
FCGR1A, HLA-DRA, CSF1R, SOCS3, IRAK4, TIFA, ARG2	0.82	0.76	0.88
FAD104, TGFBI, MAP2K6, IRAK4, LY96, CD86, ANKRD22	0.82	0.81	0.83
LDLR, INSL3, GADD45B, ARG2, PFKFB3, HLA-DRA, ITGAM	0.82	0.78	0.86
FCGR1A, TIFA, CD86, PFKFB3, TDRD9, GADD45A, LDLR	0.82	0.79	0.85

TABLE L-continued

Exemplary sets of biomarkers used in the methods or kits referenced in Sections 5.2 and 5.3			
BIOMARKER SET	ACCURACY	SPECIFICITY	SENSISTIVITY
SOCS3, CSF1R, SOD2, CD86, MAP2K6, GADD45B, PSTPIP2	0.82	0.76	0.86
MKNK1, CD86, FAD104, PRV1, SOCS3, IL10alpha, MAP2K6	0.82	0.76	0.87
TIFA, JAK2, LDLR, IRAK2, VNN1, CD86, ARG2	0.81	0.81	0.81
ANKRD22, MAPK14, INSL3, BCL2A1, CRTAP, IRAK2, FCGR1A	0.81	0.79	0.83
FAD104, INSL3, CD86, TNFRSF6, GADD45A, IFNGR1, JAK2	0.81	0.79	0.83
CSF1R, INSL3, VNN1, TIFA, IFNGR1, LDLR, ARG2	0.81	0.79	0.83
PFKFB3, BCL2A1, ANXA3, IL10alpha, FAD104, VNN1, INSL3	0.81	0.79	0.84
CSF1R, CEACAM1, MAP2K6, GADD45B, TNFSF10, TNFSF13B, TIFA	0.81	0.82	0.8
FCGR1A, ARG2, IRAK2, GADD45A, CD86, Gene_MMP9, BCL2A1	0.81	0.82	0.79
CRTAP, CEACAM1, FAD104, MKNK1, INSL3, ITGAM, SOD2	0.81	0.76	0.84
OSM, TDRD9, BCL2A1, IRAK2, GADD45A, CD86, LDLR	0.8	0.77	0.84
PFKFB3, CCL5, CSF1R, LDLR, TLR4, LY96, FAD104	0.8	0.77	0.84
IRAK4, GADD45B, CEACAM1, FAD104, CSF1R, IRAK2, MAPK14	0.8	0.75	0.85
IFNGR1, FAD104, MAP2K6, TNFRSF6, FCGR1A, IRAK2, ARG2	0.8	0.74	0.86
TGFBI, IRAK2, CRTAP, BCL2A1, ITGAM, ANXA3, FCGR1A	0.8	0.81	0.79
SOD2, PFKFB3, GADD45B, IRAK2, PRV1, SOCS3, FCGR1A	0.8	0.77	0.82
TNFRSF6, TLR4, IRAK2, ITGAM, JAK2, OSM, NCR1	0.8	0.77	0.83
IL10alpha, ANKRD22, Gene_MMP9, IL1RN, LY96, FAD104, PSTPIP2	0.8	0.76	0.84
IRAK4, INSL3, CSF1R, ITGAM, VNN1, HLA-DRA, IL18R1	0.8	0.74	0.86
IRAK2, TGFBI, MAP2K6, IL18R1, IFNGR1, CRTAP, PSTPIP2	0.8	0.73	0.87
TDRD9, ITGAM, OSM, NCR1, CD86, MAP2K6, CCL5	0.8	0.73	0.87
ANXA3, FCGR1A, TNFSF10, VNN1, TNFSF13B, ARG2, 12, CD86	0.85	0.86	0.84
INSL3, PFKFB3, MAPK14, FCGR1A, TDRD9, CSF1R, 12, IRAK4	0.85	0.84	0.85
VNN1, CSF1R, ANKRD22, OSM, GADD45A, LY96, 12, MAP2K6	0.85	0.78	0.9
ITGAM, OSM, LY96, TDRD9, ANKRD22, TLR4, 12, MKNK1	0.84	0.84	0.83
ARG2, ANXA3, MAP2K6, CCL5, CD86, OSM, 12, LDLR	0.84	0.84	0.83
OSM, IL1RN, FCGR1A, GADD45A, ARG2, IL10alpha, 12, ITGAM	0.84	0.82	0.86
TIFA, ANKRD22, TNFSF13B, CRTAP, MAP2K6, IRAK4, 12, ARG2	0.84	0.81	0.86
IRAK2, TLR4, IL10alpha, TGFBI, PRV1, FAD104, 12, MAP2K6	0.83	0.8	0.86
IL18R1, FAD104, TNFSF13B, MAP2K6, OSM, SOD2, 12, TNFRSF6	0.83	0.81	0.85
OSM, LDLR, VNN1, LY96, ARG2, MAPK14, 12, IRAK2	0.83	0.8	0.85
PRV1, ITGAM, SOD2, Gene_MMP9, OSM, JAK2, 12, ARG2	0.83	0.79	0.86
ANXA3, TNFSF10, CEACAM1, FCGR1A, HLA-DRA, IL10alpha, 12, SOCS3	0.83	0.78	0.86
ITGAM, CD86, CEACAM1, TDRD9, GADD45A, PFKFB3, 12, SOCS3	0.83	0.77	0.88
SOCS3, PRV1, ARG2, CEACAM1, LDLR, GADD45A, 12, IL10alpha	0.82	0.83	0.82

TABLE L-continued

Exemplary sets of biomarkers used in the methods or kits referenced in Sections 5.2 and 5.3			
BIOMARKER SET	ACCURACY	SPECIFICITY	SENSISTIVITY
INSL3, CSF1R, IL1RN, PSTPIP2, MKNK1, SOCS3, 12, JAK2	0.82	0.8	0.84
TDRD9, LY96, ITGAM, NCR1, PSTPIP2, IL10alpha, 12, OSM	0.82	0.75	0.9
PFKFB3, MAP2K6, ARG2, TGFBI, LDLR, FAD104, 12, MAPK14	0.82	0.84	0.8
ARG2, IL18R1, NCR1, CD86, FCGR1A, TGFBI, 12, IL1RN	0.82	0.79	0.84
HLA-DRA, CEACAM1, IFNGR1, MKNK1, LDLR, GADD45B, 12, CSF1R	0.82	0.76	0.87
IL10alpha, IL1RN, OSM, PSTPIP2, INSL3, TIFA, 12, TLR4	0.82	0.81	0.82
MKNK1, CSF1R, VNN1, OSM, ARG2, GADD45B, 12, SOCS3	0.81	0.81	0.82
IL18R1, GADD45B, TNFRSF6, TNFSF10, TIFA, JAK2, 12, GADD45A	0.81	0.79	0.84
LDLR, IL10alpha, PRV1, LY96, ANXA3, TNFRSF6, 12, CCL5	0.81	0.76	0.86
IL18R1, CD86, PFKFB3, ANKRD22, CSF1R, SOCS3, 12, TIFA	0.81	0.8	0.82
CCL5, TDRD9, PSTPIP2, ARG2, INSL3, OSM, 12, CSF1R	0.81	0.77	0.85
CEACAM1, IL10alpha, IL18R1, PSTPIP2, TGFBI, TIFA, 12, VNN1	0.81	0.77	0.85
GADD45B, Gene_MMP9, TLR4, PFKFB3, VNN1, JAK2, 12, IL18R1	0.81	0.76	0.85
FAD104, MAPK14, IFNGR1, IL18R1, TNFSF10, CD86, 12, HLA-DRA	0.81	0.76	0.86
PSTPIP2, SOCS3, OSM, CSF1R, PFKFB3, NCR1, 12, PRV1	0.81	0.75	0.86
TGFBI, SOCS3, ITGAM, TNFSF13B, IL18R1, PSTPIP2, 12, ANKRD22	0.81	0.8	0.81
CEACAM1, SOCS3, PFKFB3, TNFRSF6, PSTPIP2, OSM, 12, BCL2A1	0.81	0.79	0.82
TNFRSF6, ITGAM, BCL2A1, INSL3, CD86, TIFA, 12, PFKFB3	0.81	0.77	0.84
PFKFB3, PSTPIP2, MAP2K6, IRAK4, OSM, CCL5, 12, TNFSF10	0.81	0.76	0.85
MKNK1, TIFA, IL1RN, ARG2, SOCS3, IL10alpha, 12, IFNGR1	0.81	0.76	0.85
FAD104, TNFSF13B, OSM, BCL2A1, TDRD9, LY96, 12, SOD2	0.8	0.8	0.8
CD86, SOCS3, PSTPIP2, CCL5, OSM, TLR4, 12, MAPK14	0.8	0.77	0.83
TGFBI, LDLR, CRTAP, CSF1R, NCR1, LY96, 12, PSTPIP2	0.8	0.82	0.78
JAK2, TIFA, TNFSF10, IL18R1, CCL5, INSL3, 12, VNN1	0.8	0.82	0.78
TIFA, IL1RN, MAP2K6, HLA-DRA, OSM, FAD104, 12, INSL3	0.8	0.8	0.8
JAK2, IRAK2, PRV1, TNFSF13B, OSM, HLA-DRA, 12, IFNGR1	0.8	0.8	0.8
ANXA3, CSF1R, TLR4, SOCS3, IRAK4, PRV1, 12, INSL3	0.8	0.8	0.8
TGFBI, IRAK4, PFKFB3, SOD2, ANXA3, ITGAM, 12, TDRD9	0.8	0.8	0.8
TIFA, FCGR1A, TNFRSF6, LY96, IL10alpha, SOCS3, 12, OSM	0.8	0.78	0.81
PRV1, TLR4, CSF1R, IL18R1, PSTPIP2, TDRD9, 12, HLA-DRA	0.8	0.78	0.82
LY96, TNFSF13B, OSM, TGFBI, TIFA, FAD104, 12, NCR1	0.8	0.77	0.82
ITGAM, ARG2, IL10alpha, SOD2, LY96, OSM, 12, FCGR1A	0.8	0.76	0.83
ANKRD22, HLA-DRA, PRV1, NCR1, CSF1R, PSTPIP2, 12, LY96	0.8	0.76	0.84
Gene_MMP9, PSTPIP2, GADD45B, SOD2, ANKRD22, TNFSF13B, 12, ITGAM	0.8	0.74	0.86
ANXA3, FCGR1A, TNFSF10, VNN1, TNFSF13B, ARG2, 12, CD86	0.85	0.86	0.84

TABLE L-continued

Exemplary sets of biomarkers used in the methods or kits referenced in Sections 5.2 and 5.3			
BIOMARKER SET	ACCURACY	SPECIFICITY	SENSISTIVITY
CSF1R, PFKFB3, BCL2A1, SOCS3, NCR1, TNFSF10, FCGR1A, ARG2, CD86	0.86	0.87	0.85
PSTPIP2, ITGAM, IRAK2, OSM, NCR1, CEACAM1, PFKFB3, TLR4, ANXA3	0.84	0.81	0.87
INSL3, ARG2, LDLR, HLA-DRA, NCR1, TIFA, LY96, ITGAM, SOCS3	0.84	0.78	0.9
CD86, CSF1R, SOD2, OSM, SOCS3, BCL2A1, GADD45B, ARG2, HLA-DRA	0.83	0.79	0.87
ARG2, CD86, MAP2K6, HLA-DRA, IL10alpha, IRAK2, GADD45B, MKNK1, IL18R1	0.83	0.82	0.84
IFNGR1, BCL2A1, ARG2, TNFSF13B, GADD45A, FCGR1A, TNFRSF6, CD86, MAP2K6	0.83	0.8	0.86
OSM, TNFSF10, CSF1R, CCL5, IRAK2, INSL3, ARG2, TNFSF13B, TNFRSF6	0.83	0.82	0.83
LY96, TNFSF10, GADD45B, CRTAP, ARG2, ANXA3, CSF1R, CCL5, OSM	0.82	0.87	0.77
NCR1, LY96, FAD104, ANKRD22, BCL2A1, PSTPIP2, ARG2, PRV1, IL18R1	0.82	0.79	0.84
SOD2, IRAK2, JAK2, CCL5, IL10alpha, ARG2, BCL2A1, SOCS3, CSF1R	0.82	0.77	0.86
TNFRSF6, TGFBI, FCGR1A, IRAK4, GADD45A, LDLR, IFNGR1, CSF1R, TIFA	0.82	0.81	0.83
GADD45B, ITGAM, PRV1, SOD2, TNFSF13B, HLA-DRA, FAD104, TNFRSF6, TLR4	0.81	0.79	0.83
IRAK2, SOCS3, GADD45B, MAP2K6, PRV1, PFKFB3, CD86, IFNGR1, ANKRD22	0.81	0.83	0.8
HLA-DRA, GADD45A, FCGR1A, ANKRD22, ARG2, NCR1, BCL2A1, IRAK2, SOCS3	0.81	0.81	0.81
IRAK4, SOCS3, MKNK1, JAK2, OSM, ANXA3, VNN1, ITGAM, TNFRSF6	0.81	0.79	0.83
SOD2, JAK2, FAD104, CD86, ARG2, CCL5, MAP2K6, IFNGR1, PFKFB3	0.81	0.79	0.83
IL18R1, CSF1R, IRAK2, HLA-DRA, PFKFB3, CRTAP, CD86, TIFA, TNFSF10	0.81	0.78	0.83
MAP2K6, FAD104, TGFBI, IRAK4, CRTAP, LDLR, IRAK2, FCGR1A, ARG2	0.81	0.77	0.84
CEACAM1, SOD2, GADD45A, VNN1, IRAK4, OSM, TDRD9, GADD45B, PSTPIP2	0.81	0.73	0.88
PSTPIP2, ANKRD22, TNFSF10, INSL3, HLA-DRA, NCR1, TNFSF13B, CSF1R, Gene_MMP9	0.81	0.84	0.78
JAK2, MAP2K6, CSF1R, IRAK2, TNFSF10, LDLR, OSM, BCL2A1, ARG2	0.81	0.81	0.8
Gene_MMP9, MAP2K6, IL18R1, VNN1, INSL3, ANKRD22, CCL5, PFKFB3, MAPK14	0.81	0.8	0.81
IL18R1, ARG2, FCGR1A, CRTAP, GADD45B, FAD104, IRAK4, MAPK14, TDRD9	0.81	0.8	0.82
SOD2, PRV1, MKNK1, FCGR1A, CD86, GADD45A, IL18R1, TNFSF13B, HLA-DRA	0.81	0.78	0.83
ANXA3, TNFRSF6, MAP2K6, OSM, ANKRD22, IL18R1, MAPK14, GADD45A, GADD45B	0.81	0.78	0.83
OSM, IRAK2, ANXA3, TNFSF13B, IL18R1, ANKRD22, MAP2K6, IL10alpha, FAD104	0.81	0.78	0.83
ITGAM, SOD2, CSF1R, TGFBI, IFNGR1, TDRD9, JAK2, ARG2, GADD45A	0.81	0.73	0.87
INSL3, ITGAM, OSM, TIFA, IRAK2, MKNK1, SOCS3, TNFSF10, ANKRD22	0.8	0.84	0.77
GADD45A, PFKFB3, SOD2, IRAK2, MAPK14, INSL3, IRAK4, ITGAM, ARG2	0.8	0.79	0.82
NCR1, INSL3, ARG2, IFNGR1, LDLR, OSM, PRV1, GADD45B, CD86	0.8	0.78	0.83
IRAK2, FAD104, TLR4, CSF1R, PRV1, OSM, MKNK1, BCL2A1, CD86	0.8	0.77	0.83

TABLE L-continued

Exemplary sets of biomarkers used in the methods or kits referenced in Sections 5.2 and 5.3			
BIOMARKER SET	ACCURACY	SPECIFICITY	SENSISTIVITY
NCR1, SOCS3, HLA-DRA, PFKFB3, FAD104, IRAK4, VNN1, CCL5, MAP2K6	0.8	0.74	0.86
CRTAP, TLR4, PFKFB3, CSF1R, TIFA, PSTPIP2, PRV1, IFNGR1, CCL5	0.8	0.82	0.78
LY96, SOD2, IL18R1, TNFRSF6, TLR4, MAP2K6, FAD104, Gene_MMP9, NCR1	0.8	0.81	0.79
ITGAM, SOD2, SOCS3, LDLR, MAP2K6, FAD104, NCR1, CSF1R, CD86	0.8	0.8	0.8
CRTAP, ARG2, SOD2, TDRD9, TNFRSF6, TIFA, OSM, Gene_MMP9, HLA-DRA	0.8	0.8	0.8
OSM, LY96, CEACAM1, IRAK4, INSL3, PSTPIP2, PRV1, IRAK2, JAK2	0.8	0.78	0.82
CD86, IL1RN, IFNGR1, ANXA3, CSF1R, ITGAM, NCR1, TDRD9, MAP2K6	0.8	0.78	0.82
TNFSF13B, JAK2, IRAK4, TDRD9, HLA- DRA, SOCS3, PSTPIP2, FAD104, SOD2	0.8	0.78	0.82
Gene_MMP9, SOD2, JAK2, CD86, HLA- DRA, IRAK2, CEACAM1, MAPK14, ANXA3	0.8	0.74	0.85
GADD45B, ITGAM, TLR4, NCR1, CD86, TNFSF13B, HLA-DRA, FCGR1A, OSM	0.8	0.71	0.88
OSM, GADD45B, CSF1R, CCL5, ANXA3, CEACAM1, CD86, TNFSF10, ARG2, LY96, TDRD9	0.85	0.85	0.84
NCR1, HLA-DRA, BCL2A1, ARG2, SOCS3, IL18R1, PSTPIP2, VNN1, CD86, GADD45A, CCL5	0.84	0.84	0.84
PFKFB3, SOCS3, TNFRSF6, GADD45A, OSM, TDRD9, IL18R1, NCR1, CSF1R, ANXA3, PSTPIP2	0.84	0.8	0.87
ARG2, IFNGR1, MAPK14, Gene_MMP9, IRAK4, CEACAM1, ITGAM, ANKRD22, GADD45B, VNN1, OSM	0.84	0.8	0.88
BCL2A1, LY96, GADD45B, IL10alpha, CRTAP, OSM, IFNGR1, IL1RN, TIFA, IRAK4, GADD45A	0.84	0.82	0.86
TGFBI, SOCS3, MAP2K6, ANXA3, TLR4, IL1RN, VNN1, HLA-DRA, TIFA, JAK2, TDRD9	0.83	0.77	0.89
TNFSF13B, GADD45A, ANXA3, IL18R1, FCGR1A, JAK2, CD86, SOCS3, INSL3, CRTAP, NCR1	0.83	0.83	0.83
LY96, INSL3, TNFSF10, MAP2K6, OSM, ITGAM, JAK2, CD86, FCGR1A, IL10alpha, CCL5	0.83	0.78	0.88
ARG2, OSM, TLR4, NCR1, CCL5, BCL2A1, IL1RN, GADD45A, MAPK14, SOCS3, TDRD9	0.83	0.76	0.88
INSL3, IL18R1, IFNGR1, ARG2, IL10alpha, LY96, CRTAP, LDLR, JAK2, CSF1R, VNN1	0.83	0.82	0.83
ANXA3, IFNGR1, GADD45A, TNFRSF6, CCL5, JAK2, FAD104, IL1RN, ARG2, IL10alpha, INSL3	0.83	0.79	0.86
CRTAP, TNFRSF6, LDLR, VNN1, HLA- DRA, SOCS3, TGFBI, TNFSF10, IFNGR1, ARG2, FCGR1A	0.82	0.86	0.79
GADD45A, VNN1, MKNK1, CCL5, IL10alpha, PSTPIP2, IRAK2, TNFRSF6, CEACAM1, FAD104, TGFBI	0.82	0.83	0.82
HLA-DRA, BCL2A1, PSTPIP2, PFKFB3, JAK2, TNFSF10, ARG2, CEACAM1, IL18R1, MAPK14, CSF1R	0.82	0.82	0.83
GADD45B, TNFSF10, TNFSF13B, OSM, VNN1, PRV1, MKNK1, Gene_MMP9, ANXA3, TGFBI, HLA-DRA	0.82	0.82	0.83
GADD45A, IFNGR1, IRAK4, TGFBI, NCR1, FAD104, INSL3, IL10alpha, OSM, TIFA, CSF1R	0.82	0.75	0.88
Gene_MMP9, IRAK2, JAK2, TGFBI, BCL2A1, PSTPIP2, GADD45A, ARG2, OSM, CEACAM1, IFNGR1	0.82	0.83	0.81

TABLE L-continued

Exemplary sets of biomarkers used in the methods or kits referenced in Sections 5.2 and 5.3			
BIOMARKER SET	ACCURACY	SPECIFICITY	SENSISTIVITY
MAP2K6, FCGR1A, TNFSF13B, SOD2, NCR1, ANXA3, TLR4, CD86, ITGAM, IRAK2, INSL3	0.82	0.79	0.85
FAD104, ARG2, NCR1, ANKRD22, OSM, CSF1R, BCL2A1, CRTAP, LY96, SOD2, TNFRSF6	0.82	0.78	0.85
LY96, TDRD9, CD86, GADD45A, ARG2, VNN1, IL10alpha, SOD2, CRTAP, TIFA, FCGR1A	0.82	0.82	0.81
BCL2A1, VNN1, LDLR, TLR4, OSM, IRAK4, IRAK2, CRTAP, IFNGR1, TGFBI, CD86	0.82	0.82	0.81
CCL5, IFNGR1, TIFA, SOCS3, INSL3, TLR4, IRAK4, ANXA3, TGFBI, TDRD9, CSF1R	0.82	0.81	0.82
VNN1, SOD2, CCL5, BCL2A1, HLA-DRA, ANKRD22, CD86, TDRD9, TLR4, FCGR1A, TNFSF10	0.82	0.79	0.85
CEACAM1, OSM, IRAK4, MAP2K6, PSTPIP2, GADD45A, IRAK2, PRV1, IL1RN, TNFSF10, PFKFB3	0.82	0.77	0.85
TNFSF10, IL1RN, IFNGR1, TIFA, FCGR1A, PSTPIP2, OSM, ANXA3, TGFBI, INSL3, CRTAP	0.81	0.82	0.81
LDLR, VNN1, GADD45B, IL18R1, GADD45A, Gene_MMP9, FAD104, IL1RN, IRAK4, JAK2, TGFBI	0.81	0.8	0.83
FCGR1A, OSM, GADD45A, IL18R1, GADD45B, TLR4, MAP2K6, CRTAP, TIFA, CCL5, BCL2A1	0.81	0.79	0.83
CSF1R, ITGAM, HLA-DRA, MAP2K6, JAK2, FCGR1A, OSM, LDLR, SOCS3, TNFRSF6, IL18R1	0.81	0.78	0.85
IL10alpha, IRAK2, OSM, TIFA, TNFSF10, FAD104, GADD45B, ITGAM, CD86, VNN1, SOD2	0.81	0.75	0.87
ARG2, GADD45A, LDLR, TNFRSF6, CEACAM1, ANKRD22, MAPK14, IRAK4, SOD2, INSL3, PSTPIP2	0.81	0.84	0.78
TGFBI, TNFRSF6, IRAK4, IRAK2, OSM, TNFSF13B, TIFA, FAD104, ANKRD22, MAPK14, CD86	0.81	0.82	0.79
VNN1, INSL3, TNFSF10, TGFBI, JAK2, CRTAP, IRAK2, TNFRSF6, TNFSF13B, LY96, OSM	0.81	0.82	0.8
GADD45B, OSM, SOD2, FCGR1A, VNN1, CEACAM1, TIFA, PSTPIP2, IL1RN, TDRD9, LY96	0.81	0.77	0.85
PFKFB3, LDLR, IL10alpha, IRAK4, ANXA3, NCR1, IL18R1, VNN1, TDRD9, TNFSF13B, CSF1R	0.81	0.77	0.85
CD86, TNFRSF6, PFKFB3, MKNK1, OSM, JAK2, FAD104, IL10alpha, BCL2A1, SOCS3, IRAK4	0.81	0.76	0.85
OSM, GADD45A, TNFSF10, IFNGR1, CRTAP, JAK2, ANKRD22, HLA-DRA, TNFSF13B, SOCS3, FCGR1A	0.81	0.75	0.87
CCL5, CD86, HLA-DRA, SOCS3, TGFBI, PSTPIP2, ANXA3, GADD45A, CSF1R, IRAK4, FAD104, MAPK14	0.84	0.85	0.82
IRAK2, CD86, IL1RN, TLR4, ANKRD22, ANXA3, IL10alpha, GADD45B, BCL2A1, CSF1R, INSL3, FCGR1A	0.84	0.82	0.85
CD86, TNFRSF6, TIFA, GADD45B, CEACAM1, TNFSF13B, OSM, IL18R1, CCL5, ITGAM, TGFBI, FAD104	0.84	0.8	0.87
NCR1, CCL5, BCL2A1, IL18R1, ARG2, MKNK1, FCGR1A, CD86, GADD45B, INSL3, IRAK4, ANXA3	0.83	0.82	0.85
TNFSF13B, IFNGR1, Gene_MMP9, SOD2, LDLR, NCR1, CD86, INSL3, SOCS3, VNN1, PSTPIP2, CEACAM1	0.83	0.8	0.86

TABLE L-continued

Exemplary sets of biomarkers used in the methods or kits referenced in Sections 5.2 and 5.3			
BIOMARKER SET	ACCURACY	SPECIFICITY	SENSISTIVITY
SOD2, INSL3, TDRD9, OSM, TNFSF13B, BCL2A1, JAK2, CSF1R, ANXA3, TNFSF10, GADD45A, CRTAP	0.83	0.82	0.84
IL10alpha, MKNK1, GADD45A, TGFB1, MAPK14, IRAK4, TDRD9, IL1RN, TNFRSF6, FCGR1A, ITGAM, CD86	0.83	0.79	0.86
TNFRSF6, IL10alpha, PSTPIP2, HLA-DRA, CRTAP, ARG2, MKNK1, NCR1, OSM, INSL3, VNN1, FAD104	0.83	0.78	0.87
ANXA3, PRV1, LDLR, TNFSF13B, PFKFB3, TNFRSF6, VNN1, ARG2, ANKRD22, INSL3, NCR1, OSM	0.82	0.8	0.84
FCGR1A, HLA-DRA, IFNGR1, CD86, LY96, ANXA3, MAP2K6, TDRD9, IL18R1, PRV1, SOCS3, TIFA	0.82	0.76	0.89
GADD45B, OSM, ITGAM, CSF1R, CD86, CEACAM1, IFNGR1, SOCS3, MAP2K6, IL1RN, FAD104, CCL5	0.82	0.84	0.8
TGFB1, PRV1, JAK2, FCGR1A, ANKRD22, TNFSF10, VNN1, SOCS3, PSTPIP2, IRAK2, INSL3, FAD104	0.82	0.83	0.81
FCGR1A, GADD45A, SOD2, OSM, ARG2, PFKFB3, ANKRD22, IL10alpha, CCL5, SOCS3, CD86, ITGAM	0.82	0.8	0.83
LDLR, MAP2K6, INSL3, TDRD9, NCR1, IL1RN, HLA-DRA, ARG2, MKNK1, MAPK14, OSM, PFKFB3	0.82	0.84	0.79
IL1RN, PFKFB3, TIFA, OSM, IRAK2, TGFB1, INSL3, TNFSF13B, TNFRSF6, MAP2K6, PSTPIP2, CEACAM1	0.82	0.83	0.81
LY96, TNFSF13B, HLA-DRA, IRAK2, FCGR1A, ANXA3, CEACAM1, FAD104, TDRD9, IL1RN, ARG2, LDLR	0.82	0.82	0.82
IL1RN, ARG2, IRAK2, IRAK4, SOCS3, IL10alpha, CCL5, Gene_MMP9, MAPK14, FAD104, LY96, TGFB1	0.82	0.81	0.82
BCL2A1, LY96, ITGAM, OSM, TNFSF10, INSL3, CD86, IRAK2, MAP2K6, IFNGR1, PRV1, TNFRSF6	0.81	0.81	0.82
BCL2A1, ANXA3, LY96, TNFSF10, NCR1, OSM, MAPK14, MKNK1, IFNGR1, GADD45A, INSL3, ANKRD22, TNFSF13B	0.83	0.83	0.83
LY96, GADD45B, MAPK14, OSM, MKNK1, BCL2A1, ARG2, IL1RN, INSL3, PFKFB3, LDLR, CRTAP, TIFA	0.83	0.82	0.84
OSM, CD86, GADD45B, IRAK4, MAPK14, SOCS3, VNN1, ARG2, TNFSF13B, TDRD9, PRV1, IL1RN, IL18R1	0.83	0.82	0.84
OSM, NCR1, HLA-DRA, TNFSF10, PSTPIP2, IL1RN, SOCS3, INSL3, TNFRSF6, MAPK14, Gene_MMP9, CEACAM1, IL18R1	0.83	0.82	0.84
CCL5, ARG2, IL10alpha, MAPK14, CSF1R, GADD45B, LDLR, SOD2, Gene_MMP9, IFNGR1, IL18R1, CEACAM1, CD86	0.83	0.8	0.85
TDRD9, SOCS3, Gene_MMP9, IL18R1, CRTAP, ANXA3, PRV1, ARG2, CD86, ITGAM, OSM, NCR1, VNN1	0.83	0.85	0.81
SOD2, JAK2, PSTPIP2, MAPK14, MAP2K6, FCGR1A, CCL5, ITGAM, CD86, GADD45B, IL1RN, HLA-DRA, VNN1	0.83	0.83	0.83
IRAK4, JAK2, SOD2, Gene_MMP9, PSTPIP2, PFKFB3, HLA-DRA, TNFRSF6, FAD104, ARG2, IFNGR1, IRAK2, MAP2K6	0.83	0.81	0.84
PSTPIP2, MAPK14, CCL5, Gene_MMP9, TNFRSF6, IL10alpha, LY96, IL1RN, ARG2, SOCS3, TLR4, OSM, HLA-DRA	0.83	0.79	0.86
CRTAP, CEACAM1, ARG2, JAK2, TNFSF10, VNN1, PSTPIP2, IRAK2, TNFRSF6, ITGAM, SOCS3, OSM, IL18R1	0.83	0.79	0.87

TABLE L-continued

Exemplary sets of biomarkers used in the methods or kits referenced in Sections 5.2 and 5.3			
BIOMARKER SET	ACCURACY	SPECIFICITY	SENSISTIVITY
VNN1, PSTPIP2, GADD45B, ITGAM, IL1RN, FAD104, NCR1, TIFA, OSM, TDRD9, SOD2, ARG2, TGFB1	0.83	0.77	0.88
TGFB1, IL1RN, INSL3, PSTPIP2, NCR1, FAD104, HLA-DRA, CD86, IRAK4, IL10alpha, ARG2, CSF1R, MAP2K6	0.82	0.84	0.81
FAD104, IRAK2, TIFA, TGFB1, IL18R1, MAPK14, SOCS3, PSTPIP2, CD86, PRV1, NCR1, FCGR1A, ANXA3	0.82	0.82	0.83
GADD45A, HLA-DRA, INSL3, ANKRD22, ANXA3, CD86, IRAK4, GADD45B, PFKFB3, ITGAM, VNN1, NCR1, JAK2	0.82	0.79	0.85
MKNK1, CCL5, PSTPIP2, ANXA3, VNN1, LY96, IRAK2, IFNGR1, CRTAP, PFKFB3, IL18R1, LDLR, FAD104	0.82	0.86	0.78
TNFSF10, OSM, FCGR1A, IRAK4, TLR4, SOCS3, IL18R1, CRTAP, GADD45B, IL1RN, IL10alpha, PRV1, JAK2	0.82	0.81	0.83
FAD104, ITGAM, ARG2, PSTPIP2, TLR4, NCR1, IL1RN, MAP2K6, FCGR1A, PFKFB3, LDLR, IFNGR1, BCL2A1	0.82	0.79	0.84
LDLR, ARG2, NCR1, MKNK1, GADD45B, GADD45A, CEACAM1, PSTPIP2, Gene_MMP9, CCL5, BCL2A1, TIFA, TDRD9	0.82	0.79	0.84
IRAK2, Gene_MMP9, INSL3, ARG2, OSM, ITGAM, PSTPIP2, TNFSF13B, FCGR1A, BCL2A1, CRTAP, PRV1, MAP2K6	0.81	0.81	0.82
CEACAM1, PSTPIP2, TLR4, IFNGR1, GADD45B, CSF1R, CD86, VNN1, IL18R1, ANKRD22, MAPK14, OSM, CCL5, IRAK4	0.85	0.89	0.83
LY96, ANKRD22, Gene_MMP9, ARG2, GADD45A, MKNK1, CD86, PSTPIP2, OSM, FAD104, FCGR1A, IL18R1, TIFA, ITGAM	0.85	0.84	0.86
ARG2, ANKRD22, VNN1, TLR4, OSM, TIFA, TGFB1, TDRD9, ANXA3, CCL5, TNFRSF6, GADD45B, FAD104, CD86	0.84	0.82	0.86
IFNGR1, TLR4, CRTAP, ANKRD22, Gene_MMP9, JAK2, INSL3, ITGAM, IRAK4, HLA-DRA, BCL2A1, OSM, TNFSF10, NCR1	0.84	0.79	0.87
TNFSF10, VNN1, TDRD9, CSF1R, OSM, IFNGR1, TLR4, PSTPIP2, TIFA, ARG2, FCGR1A, CD86, MAPK14, MAP2K6	0.83	0.83	0.83
LDLR, IL18R1, BCL2A1, IL1RN, ARG2, IRAK2, JAK2, GADD45A, ANKRD22, MAP2K6, OSM, CD86, IRAK4, SOD2	0.83	0.83	0.84
IL1RN, IRAK4, VNN1, CRTAP, TNFSF10, IFNGR1, FAD104, ARG2, OSM, NCR1, JAK2, ANXA3, CEACAM1, TDRD9	0.83	0.8	0.86
CD86, FCGR1A, MKNK1, TNFRSF6, GADD45B, LY96, NCR1, PSTPIP2, HLA-DRA, VNN1, ANXA3, IRAK4, ARG2, TGFB1	0.83	0.78	0.88
IRAK2, ANKRD22, JAK2, CD86, INSL3, TNFSF10, OSM, PSTPIP2, IL10alpha, CCL5, TDRD9, GADD45B, Gene_MMP9, LY96	0.83	0.77	0.88
LY96, FCGR1A, CCL5, IL18R1, VNN1, TNFSF10, MAP2K6, PRV1, IRAK4, IL1RN, TLR4, PSTPIP2, PFKFB3, TGFB1	0.83	0.83	0.83
SOD2, IL1RN, JAK2, PRV1, IRAK2, CD86, TGFB1, CCL5, MAPK14, TLR4, INSL3, PFKFB3, GADD45B, LY96	0.83	0.83	0.83
TDRD9, FCGR1A, NCR1, IFNGR1, ARG2, SOD2, TNFRSF6, CD86, PFKFB3, LDLR, JAK2, CCL5, ANKRD22, FAD104	0.83	0.81	0.85
MAPK14, INSL3, MAP2K6, CCL5, CSF1R, CD86, GADD45A, SOCS3, GADD45B, ANXA3, TGFB1, TNFRSF6, IFNGR1, CRTAP	0.83	0.82	0.83
GADD45B, MAPK14, GADD45A, IL1RN, CEACAM1, CRTAP, MKNK1, IL18R1, NCR1, FCGR1A, TIFA, MAP2K6, CD86, TLR4	0.83	0.81	0.84

TABLE L-continued

Exemplary sets of biomarkers used in the methods or kits referenced in Sections 5.2 and 5.3			
BIOMARKER SET	ACCURACY	SPECIFICITY	SENSISTIVITY
ARG2, ANKRD22, OSM, LDLR, CCL5, IL1RN, FCGR1A, PFKFB3, CSF1R, ANXA3, HLA-DRA, INSL3, NCR1, TIFA	0.82	0.83	0.82
TNFSF10, ANXA3, OSM, JAK2, VNN1, ANKRD22, INSL3, IFNGR1, CD86, MAPK14, GADD45B, TNFRSF6, MAP2K6, LY96	0.82	0.81	0.83
TGFBI, IL18R1, IFNGR1, TDRD9, ANXA3, TNFSF10, ANKRD22, CD86, TNFRSF6, BCL2A1, FAD104, Gene_MMP9, TNFSF13B, CRTAP	0.82	0.8	0.84
OSM, ANXA3, SOCS3, INSL3, ITGAM, SOD2, NCR1, TNFSF10, BCL2A1, PSTPIP2, TLR4, IRAK2, Gene_MMP9, IL18R1	0.82	0.87	0.79
SOD2, IRAK4, TNFRSF6, PRV1, FCGR1A, LDLR, MAP2K6, TIFA, CEACAM1, IL18R1, SOCS3, OSM, IL10alpha, MKNK1	0.82	0.84	0.8
TLR4, MKNK1, SOD2, SOCS3, FAD104, HLA-DRA, PSTPIP2, ANKRD22, TIFA, TNFRSF6, JAK2, TNFSF10, ARG2, CSF1R, TLR4	0.85	0.83	0.86
CCL5, MAP2K6, SOCS3, IFNGR1, TGFBI, ANXA3, OSM, GADD45A, TNFSF10, Gene_MMP9, TNFRSF6, TIFA, ARG2, INSL3, SOCS3	0.84	0.85	0.83
ANXA3, IL18R1, VNN1, NCR1, TIFA, INSL3, TGFBI, MAPK14, CEACAM1, CRTAP, CSF1R, TDRD9, IL10alpha, CCL5, MAPK14	0.84	0.84	0.83
TLR4, MKNK1, SOD2, SOCS3, FAD104, HLA-DRA, PSTPIP2, ANKRD22, TIFA, TNFRSF6, JAK2, TNFSF10, ARG2, CSF1R, IRAK4	0.85	0.83	0.86
CCL5, MAP2K6, SOCS3, IFNGR1, TGFBI, ANXA3, OSM, GADD45A, TNFSF10, Gene_MMP9, TNFRSF6, TIFA, ARG2, INSL3, TLR4	0.84	0.85	0.83
ANXA3, IL18R1, VNN1, NCR1, TIFA, INSL3, TGFBI, MAPK14, CEACAM1, CRTAP, CSF1R, TDRD9, IL10alpha, CCL5, SOCS3	0.84	0.84	0.83
IL18R1, MAP2K6, INSL3, IRAK4, CCL5, PFKFB3, CSF1R, LDLR, ITGAM, GADD45A, ARG2, PSTPIP2, TLR4, CD86, MAPK14	0.84	0.79	0.88
SOD2, IFNGR1, CEACAM1, OSM, FAD104, HLA-DRA, CRTAP, IL10alpha, TGFBI, GADD45A, ITGAM, IL18R1, CCL5, TLR4, FCGR1A	0.83	0.84	0.83
SOCS3, OSM, TIFA, TNFRSF6, INSL3, LDLR, IL18R1, PFKFB3, TGFBI, IL10alpha, GADD45B, ARG2, TNFSF10, VNN1, ANXA3	0.83	0.83	0.84
PRV1, PFKFB3, CEACAM1, FCGR1A, TIFA, MKNK1, ARG2, GADD45B, IL18R1, CD86, ITGAM, VNN1, IFNGR1, OSM, JAK2	0.83	0.82	0.85
NCR1, INSL3, HLA-DRA, TNFSF10, TNFRSF6, FCGR1A, OSM, GADD45B, MKNK1, TNFSF13B, CSF1R, LY96, MAPK14, PRV1, CCL5	0.83	0.82	0.84
FCGR1A, CD86, CEACAM1, ANXA3, FAD104, CRTAP, JAK2, MKNK1, MAPK14, IFNGR1, GADD45A, PFKFB3, ANKRD22, IL18R1, LY96	0.83	0.79	0.87
IRAK2, IL10alpha, INSL3, FAD104, TIFA, SOD2, IFNGR1, IL1RN, HLA-DRA, LY96, IL18R1, CCL5, CD86, TDRD9, TNFSF10	0.83	0.78	0.87
LY96, BCL2A1, Gene_MMP9, OSM, ARG2, MAP2K6, INSL3, ITGAM, MAPK14, TIFA, IRAK2, PSTPIP2, FCGR1A, CEACAM1, IFNGR1	0.83	0.8	0.85

TABLE L-continued

Exemplary sets of biomarkers used in the methods or kits referenced in Sections 5.2 and 5.3			
BIOMARKER SET	ACCURACY	SPECIFICITY	SENSISTIVITY
IL18R1, BCL2A1, PFKFB3, Gene_MMP9, IL1RN, IL10alpha, SOCS3, PSTPIP2, CRTAP, OSM, CD86, FCGR1A, FAD104, JAK2, SOD2	0.83	0.76	0.88
MKKNK1, CRTAP, PRV1, IL1RN, GADD45A, TNFRSF6, FAD104, HLA-DRA, CEACAM1, PSTPIP2, OSM, JAK2, IL18R1, LDLR, IRAK4	0.82	0.82	0.82
FCGR1A, BCL2A1, IFNGR1, CRTAP, VNN1, TIFA, CCL5, NCR1, OSM, HLA-DRA, IRAK4, INSL3, MAP2K6, TNFSF13B, ARG2	0.82	0.8	0.84
FAD104, BCL2A1, PRV1, MKKNK1, CRTAP, IRAK4, PFKFB3, SOD2, CD86, ARG2, FCGR1A, ANKRD22, INSL3, IFNGR1, LDLR	0.82	0.77	0.87
SOCS3, CD86, FCGR1A, MAP2K6, TGFBI, IRAK2, PSTPIP2, CCL5, IL1RN, GADD45B, TDRD9, OSM, IL10alpha, PFKFB3, FAD104	0.82	0.84	0.8
TIFA, SOD2, LDLR, FCGR1A, BCL2A1, TNFSF13B, ARG2, PSTPIP2, MAPK14, LY96, Gene_MMP9, IFNGR1, GADD45B, ANXA3, PRV1, CD86	0.86	0.84	0.87
HLA-DRA, IRAK2, FCGR1A, ANXA3, ITGAM, LY96, TDRD9, SOCS3, IL1RN, PFKFB3, GADD45B, TNFSF13B, TLR4, ARG2, CSF1R, FAD104	0.84	0.83	0.84
OSM, CRTAP, CEACAM1, NCR1, IRAK4, TLR4, FAD104, MKKNK1, TDRD9, PSTPIP2, IL1RN, CSF1R, MAP2K6, ITGAM, ARG2, IFNGR1	0.83	0.81	0.86
TIFA, IL10alpha, VNN1, OSM, MAP2K6, GADD45B, PSTPIP2, TDRD9, TNFRSF6, INSL3, IL1RN, FAD104, TNFSF10, TGFBI, IL18R1, TLR4	0.83	0.77	0.9
GADD45A, CSF1R, INSL3, BCL2A1, TDRD9, LDLR, HLA-DRA, MAP2K6, PSTPIP2, CCL5, ANXA3, PRV1, TNFRSF6, TLR4, CD86, JAK2	0.83	0.82	0.84
TDRD9, PFKFB3, MAPK14, IL1RN, IFNGR1, FCGR1A, MAP2K6, TNFRSF6, ARG2, VNN1, CRTAP, LDLR, CEACAM1, FAD104, NCR1, TNFSF10	0.83	0.85	0.8
ARG2, IL10alpha, TLR4, PRV1, INSL3, OSM, CD86, TGFBI, SOCS3, GADD45B, TIFA, LDLR, IRAK2, GADD45A, SOD2, TNFSF13B	0.83	0.82	0.83
TNFSF10, PRV1, SOCS3, FAD104, TNFRSF6, ARG2, Gene_MMP9, FCGR1A, TGFBI, NCR1, CRTAP, MAP2K6, ANXA3, CSF1R, HLA-DRA, JAK2	0.83	0.8	0.85
TNFRSF6, BCL2A1, VNN1, ANXA3, SOCS3, GADD45A, CRTAP, CCL5, FAD104, ANKRD22, MKKNK1, FCGR1A, SOD2, IRAK2, MAPK14, Gene_MMP9	0.83	0.8	0.85
FAD104, OSM, LDLR, TNFSF10, GADD45B, HLA-DRA, TNFRSF6, GADD45A, CD86, TDRD9, ITGAM, ANXA3, IFNGR1, MAPK14, CSF1R, TGFBI	0.82	0.78	0.87
CSF1R, PRV1, ANXA3, SOD2, PSTPIP2, CEACAM1, IFNGR1, IRAK4, LY96, MAPK14, IL10alpha, MKKNK1, TNFRSF6, OSM, TGFBI, INSL3	0.82	0.77	0.87
PSTPIP2, ARG2, MAP2K6, INSL3, SOCS3, JAK2, FAD104, ANKRD22, HLA-DRA, ITGAM, GADD45B, LY96, IRAK2, PFKFB3, TNFRSF6, IFNGR1	0.82	0.76	0.89
CRTAP, MKKNK1, BCL2A1, PRV1, CD86, TNFRSF6, PSTPIP2, MAPK14, TNFSF13B, ARG2, PFKFB3, CEACAM1, FAD104, Gene_MMP9, OSM, SOD2	0.82	0.88	0.77

TABLE L-continued

Exemplary sets of biomarkers used in the methods or kits referenced in Sections 5.2 and 5.3			
BIOMARKER SET	ACCURACY	SPECIFICITY	SENSISTIVITY
MKNK1, SOCS3, CRTAP, FCGR1A, CD86, IL10alpha, GADD45A, IL18R1, IRAK2, CCL5, JAK2, ANKRD22, TIFA, TGFBI, CSF1R, BCL2A1	0.82	0.82	0.82
GADD45B, CEACAM1, ANKRD22, IRAK4, LDLR, CRTAP, MKNK1, OSM, MAPK14, MAP2K6, INSL3, GADD45A, PFKFB3, TNFSF10, CSF1R, TIFA	0.82	0.81	0.82
CSF1R, INSL3, TNFRSF6, BCL2A1, CD86, CEACAM1, IL10alpha, IL18R1, TLR4, ITGAM, TNFSF10, OSM, ARG2, SOD2, FCGR1A, PSTPIP2	0.82	0.79	0.85
NCR1, LDLR, MKNK1, INSL3, BCL2A1, JAK2, FCGR1A, IL1RN, TNFRSF6, PRV1, GADD45B, ARG2, MAP2K6, OSM, VNN1, TDRD9	0.82	0.78	0.85
TLR4, CD86, MAPK14, TNFSF13B, INSL3, CRTAP, NCR1, ARG2, GADD45A, CSF1R, TNFRSF6, MAP2K6, JAK2, MKNK1, ANKRD22, OSM	0.82	0.85	0.79
CSF1R, CCL5, ARG2, BCL2A1, FCGR1A, MKNK1, TDRD9, IFNGR1, PFKFB3, ITGAM, JAK2, OSM, GADD45B, FAD104, NCR1, HLA-DRA	0.82	0.85	0.79
IFNGR1, FCGR1A, TLR4, OSM, PSTPIP2, IL18R1, NCR1, SOCS3, PFKFB3, INSL3, LDLR, TNFRSF6, SOD2, GADD45B, IL10alpha, CCL5, IL1RN	0.86	0.82	0.9
CEACAM1, IL18R1, SOCS3, CRTAP, LDLR, HLA-DRA, LY96, IL1RN, IL10alpha, BCL2A1, GADD45A, TIFA, FAD104, ANKRD22, OSM, CCL5, IFNGR1	0.86	0.84	0.88
FAD104, GADD45B, HLA-DRA, VNN1, IL10alpha, CD86, JAK2, INSL3, TDRD9, TLR4, IRAK4, SOD2, LDLR, CCL5, MKNK1, ARG2, IL18R1	0.85	0.79	0.91
IL18R1, PRV1, IL1RN, TNFSF10, FAD104, ITGAM, FCGR1A, INSL3, MAP2K6, LDLR, TNFSF13B, IRAK2, OSM, PFKFB3, TGFBI, IL10alpha, LY96	0.85	0.81	0.89
IRAK2, HLA-DRA, IFNGR1, MAP2K6, TLR4, ITGAM, SOCS3, CD86, ARG2, VNN1, IL18R1, ANXA3, FCGR1A, IL1RN, Gene_MMP9, TGFBI, IL10alpha	0.85	0.81	0.89
MAP2K6, IL18R1, IL1RN, CSF1R, TNFRSF6, FCGR1A, NCR1, TDRD9, TNFSF10, SOCS3, CCL5, IFNGR1, TIFA, CRTAP, GADD45B, IL10alpha, TGFBI	0.84	0.81	0.87
CD86, CCL5, IRAK4, GADD45A, ANXA3, OSM, JAK2, INSL3, SOCS3, BCL2A1, FAD104, MAPK14, TIFA, TLR4, NCR1, PRV1, TDRD9	0.84	0.8	0.88
BCL2A1, IL18R1, TLR4, OSM, CD86, FAD104, PRV1, JAK2, MAPK14, TNFRSF6, CEACAM1, IL1RN, IL10alpha, SOD2, Gene_MMP9, CSF1R, PFKFB3	0.84	0.8	0.89
LY96, TIFA, IL10alpha, ANXA3, LDLR, JAK2, IFNGR1, IRAK2, MAP2K6, TGFBI, MAPK14, TDRD9, FCGR1A, ITGAM, TNFSF10, GADD45B, SOCS3	0.84	0.81	0.87
TNFSF13B, FAD104, SOD2, SOCS3, CEACAM1, TDRD9, ARG2, CD86, IRAK2, PFKFB3, FCGR1A, NCR1, MAPK14, CRTAP, LDLR, GADD45A, TNFRSF6	0.84	0.85	0.83
IRAK2, MKNK1, PSTPIP2, ANXA3, HLA- DRA, TNFSF10, IFNGR1, PFKFB3, OSM, PRV1, IL1RN, IL10alpha, FAD104, CD86, TIFA, BCL2A1, TNFSF13B	0.84	0.83	0.84

TABLE L-continued

Exemplary sets of biomarkers used in the methods or kits referenced in Sections 5.2 and 5.3			
BIOMARKER SET	ACCURACY	SPECIFICITY	SENSISTIVITY
VNN1, IFNGR1, LY96, SOD2, IL18R1, SOCS3, FCGR1A, ARG2, CSF1R, Gene__MMP9, IRAK4, MAP2K6, TIFA, FAD104, HLA-DRA, GADD45B, IL1RN	0.84	0.82	0.86
CD86, Gene__MMP9, IL18R1, TNFSF13B, FCGR1A, TNFRSF6, INSL3, IL1RN, PFKFB3, PSTPIP2, NCR1, GADD45B, VNN1, CRTAP, IRAK4, MAP2K6, OSM	0.83	0.82	0.84
TNFSF13B, FAD104, PRV1, TIFA, SOD2, TDRD9, TLR4, TNFRSF6, MKNK1, OSM, MAP2K6, CCL5, ARG2, LDLR, HLA-DRA, PSTPIP2, IL18R1	0.83	0.79	0.88
IRAK4, MAP2K6, JAK2, LY96, ITGAM, CCL5, CSF1R, ARG2, FCGR1A, FAD104, CD86, TNFSF10, IL18R1, CRTAP, GADD45A, TLR4, Gene__MMP9	0.83	0.82	0.84
IRAK2, OSM, MAP2K6, TNFSF13B, ANKRD22, HLA-DRA, SOD2, TNFSF10, VNN1, ARG2, IRAK4, LY96, IFNGR1, JAK2, BCL2A1, FCGR1A, CSF1R	0.83	0.8	0.86
IL10alpha, FCGR1A, TGFBI, ANKRD22, IRAK4, CD86, TNFSF13B, TNFRSF6, IL18R1, JAK2, IL1RN, PSTPIP2, OSM, MAP2K6, GADD45A, Gene__MMP9, MAPK14	0.83	0.78	0.87
PRV1, IRAK4, MKNK1, JAK2, OSM, MAP2K6, BCL2A1, GADD45B, Gene__MMP9, IL10alpha, FAD104, ARG2, PSTPIP2, SOD2, TNFRSF6, TNFSF10, IL1RN	0.82	0.83	0.82
IL1RN, OSM, FAD104, CRTAP, IRAK4, IL10alpha, LDLR, INSL3, TNFSF10, CCL5, IL18R1, ANXA3, PRV1, ARG2, Gene__MMP9, CEACAM1, SOCS3	0.82	0.82	0.83
TNFRSF6, MAP2K6, FCGR1A, MAPK14, ARG2, INSL3, TNFSF10, NCR1, PRV1, CEACAM1, ANXA3, IL18R1, TIFA, IFNGR1, IRAK4, CCL5, VNN1	0.82	0.81	0.83
IRAK2, ANKRD22, MAPK14, TIFA, GADD45B, OSM, IL10alpha, SOD2, CCL5, GADD45A, CD86, IRAK4, SOCS3, TDRD9, MAP2K6, FAD104, PRV1, ANXA3	0.85	0.83	0.87
TLR4, LDLR, OSM, MAP2K6, GADD45A, TIFA, NCR1, IL18R1, IFNGR1, INSL3, ANXA3, IL10alpha, IL1RN, CSF1R, GADD45B, PFKFB3, TGFBI, CRTAP	0.85	0.84	0.86
HLA-DRA, GADD45A, ANXA3, ARG2, FAD104, PFKFB3, ITGAM, JAK2, MAPK14, OSM, CD86, LDLR, TIFA, CCL5, NCR1, IRAK2, SOD2, PRV1	0.84	0.85	0.83
GADD45A, INSL3, IRAK2, TNFSF10, TGFBI, IRAK4, NCR1, HLA-DRA, CEACAM1, GADD45B, MAPK14, CD86, IL18R1, CRTAP, ANKRD22, PSTPIP2, LY96, PFKFB3	0.83	0.82	0.85
MAP2K6, IL1RN, TIFA, TLR4, OSM, TGFBI, ANXA3, NCR1, IL18R1, ANKRD22, GADD45A, TNFSF10, PRV1, IRAK2, TDRD9, JAK2, Gene__MMP9, CSF1R	0.83	0.85	0.81
CD86, GADD45A, GADD45B, TNFSF13B, CRTAP, TNFRSF6, NCR1, IL10alpha, CSF1R, OSM, MKNK1, CEACAM1, TLR4, IFNGR1, IRAK2, SOCS3, TGFBI, Gene__MMP9	0.83	0.83	0.83
BCL2A1, ANKRD22, OSM, CD86, ITGAM, ANXA3, FCGR1A, CCL5, TIFA, IRAK4, HLA-DRA, NCR1, CRTAP, TLR4, CEACAM1, FAD104, ARG2, MAP2K6	0.83	0.82	0.84

TABLE L-continued

Exemplary sets of biomarkers used in the methods or kits referenced in Sections 5.2 and 5.3			
BIOMARKER SET	ACCURACY	SPECIFICITY	SENSISTIVITY
GADD45A, IFNGR1, MAP2K6, CRTAP, MAPK14, TNFSF10, LDLR, TIFA, OSM, SOCS3, CD86, ARG2, PSTPIP2, IL1RN, LY96, GADD45B, ANKRD22, TGFB1	0.83	0.82	0.84
INSL3, TLR4, BCL2A1, ANKRD22, FAD104, MAP2K6, GADD45B, ARG2, NCR1, MKNK1, ITGAM, CSF1R, IL1RN, HLA-DRA, LDLR, CRTAP, PRV1, LY96	0.83	0.81	0.85
CRTAP, HLA-DRA, ARG2, PSTPIP2, MKNK1, INSL3, TIFA, CEACAM1, JAK2, Gene_MMP9, TLR4, IRAK4, CD86, FAD104, CCL5, TNFSF10, LDLR, IFNGR1	0.83	0.81	0.86
IL18R1, TNFRSF6, PFKFB3, FAD104, GADD45A, OSM, JAK2, VNN1, MKNK1, BCL2A1, SOCS3, NCR1, TLR4, FCGR1A, CSF1R, ITGAM, IRAK4, CRTAP	0.83	0.8	0.86
FAD104, TNFRSF6, OSM, TIFA, PSTPIP2, ANXA3, TLR4, CD86, IRAK4, TNFSF13B, IL1RN, IFNGR1, ITGAM, BCL2A1, CEACAM1, MKNK1, TGFB1, ARG2	0.83	0.78	0.87
TNFSF10, BCL2A1, TGFB1, LY96, PRV1, MKNK1, SOD2, ARG2, SOCS3, CD86, IL10alpha, TNFSF13B, ITGAM, OSM, MAPK14, PSTPIP2, ANXA3, CCL5	0.83	0.85	0.81
SOCS3, OSM, CCL5, JAK2, MAP2K6, IL18R1, NCR1, CEACAM1, IRAK2, ARG2, LY96, PRV1, ITGAM, TNFSF13B, TNFSF10, TGFB1, IL10alpha, LDLR	0.83	0.85	0.81
ARG2, IRAK2, Gene_MMP9, GADD45B, MKNK1, PFKFB3, MAPK14, IRAK4, CSF1R, FCGR1A, GADD45A, TDRD9, TIFA, CD86, IL18R1, BCL2A1, CRTAP, TNFRSF6	0.83	0.83	0.82
FAD104, IL1RN, TGFB1, TLR4, BCL2A1, IFNGR1, IRAK4, PRV1, ANKRD22, CRTAP, TNFRSF6, CSF1R, ARG2, OSM, GADD45A, VNN1, INSL3, CEACAM1	0.83	0.82	0.83
CSF1R, SOCS3, FAD104, TLR4, INSL3, ANXA3, NCR1, CRTAP, IFNGR1, TIFA, OSM, MAPK14, TDRD9, IL1RN, ANKRD22, TNFRSF6, IRAK2, BCL2A1	0.83	0.81	0.84
MAP2K6, IFNGR1, CD86, FCGR1A, IRAK2, MKNK1, CRTAP, FAD104, IL10alpha, VNN1, ANXA3, NCR1, IL18R1, CEACAM1, CCL5, ARG2, MAPK14, SOCS3	0.83	0.81	0.84
IL1RN, IRAK4, JAK2, CD86, BCL2A1, TGFB1, Gene_MMP9, NCR1, IFNGR1, VNN1, SOCS3, CCL5, TNFSF13B, TDRD9, MAPK14, PRV1, OSM, TLR4	0.83	0.79	0.86
MAP2K6, CSF1R, HLA-DRA, ANKRD22, MKNK1, SOCS3, TNFSF10, LDLR, FAD104, CEACAM1, TNFSF13B, TDRD9, IRAK4, VNN1, IL18R1, OSM, PSTPIP2, Gene_MMP9	0.82	0.8	0.85
CCL5, SOD2, JAK2, IRAK4, IRAK2, Gene_MMP9, IFNGR1, TLR4, GADD45A, TNFSF10, CSF1R, IL18R1, PRV1, TNFSF13B, HLA-DRA, LDLR, CD86, SOCS3, FAD104	0.84	0.79	0.89
MAP2K6, TNFSF13B, SOD2, GADD45B, HLA-DRA, CSF1R, CCL5, TIFA, NCR1, IFNGR1, OSM, CD86, SOCS3, ARG2, IL10alpha, BCL2A1, TDRD9, LDLR, GADD45A	0.84	0.84	0.84
IFNGR1, OSM, MAPK14, CEACAM1, PFKFB3, TLR4, CSF1R, JAK2, IL18R1, TGFB1, CD86, IL10alpha, INSL3, BCL2A1, FCGR1A, GADD45B, LDLR, PSTPIP2, FAD104	0.84	0.83	0.85

TABLE L-continued

Exemplary sets of biomarkers used in the methods or kits referenced in Sections 5.2 and 5.3			
BIOMARKER SET	ACCURACY	SPECIFICITY	SENSISTIVITY
ARG2, PRV1, IRAK4, TNFRSF6, MAP2K6, SOCS3, IL18R1, HLA-DRA, IFNGR1, ANXA3, TNFSF10, JAK2, FCGR1A, GADD45A, INSL3, IL1RN, TNFSF13B, ITGAM, CSF1R	0.84	0.8	0.86
LDLR, INSL3, JAK2, TNFRSF6, PRV1, IFNGR1, OSM, ITGAM, FCGR1A, IL10alpha, NCR1, TDRD9, MAP2K6, TNFSF13B, TIFA, HLA-DRA, ANKRD22, GADD45B, IL1RN	0.83	0.82	0.84
MAPK14, SOD2, CSF1R, ITGAM, MAP2K6, TLR4, ANXA3, BCL2A1, CRTAP, IL10alpha, IRAK4, CCL5, SOCS3, TNFSF13B, ARG2, FCGR1A, CEACAM1, OSM, IL1RN	0.83	0.82	0.84
LY96, IL10alpha, GADD45A, GADD45B, IL1RN, IL18R1, PSTPIP2, ARG2, IRAK2, CEACAM1, MKNK1, PFKFB3, TNFSF10, ANKRD22, ANXA3, SOD2, MAP2K6, IRAK4, SOCS3	0.83	0.78	0.87
IL18R1, MAP2K6, ARG2, CD86, TNFSF13B, MAPK14, TNFSF10, CRTAP, GADD45A, NCR1, GADD45B, JAK2, MKNK1, TNFRSF6, VNN1, FAD104, LY96, CEACAM1, PRV1	0.82	0.82	0.83
HLA-DRA, CD86, SOCS3, TIFA, TNFSF13B, FCGR1A, JAK2, PFKFB3, MAP2K6, OSM, TGFB1, ANKRD22, CEACAM1, IRAK4, ARG2, IL18R1, SOD2, MKNK1, GADD45B	0.82	0.79	0.85
TDRD9, IRAK2, PFKFB3, CSF1R, TGFB1, SOCS3, IL10alpha, IFNGR1, TNFRSF6, VNN1, FCGR1A, PRV1, TNFSF13B, MAPK14, BCL2A1, CD86, SOD2, INSL3, ARG2	0.82	0.79	0.85
LDLR, ITGAM, IL18R1, ANXA3, GADD45A, VNN1, TDRD9, LY96, BCL2A1, CD86, IRAK2, FAD104, Gene_MMP9, TLR4, TIFA, OSM, ARG2, CRTAP, PSTPIP2	0.82	0.79	0.86
CCL5, TGFB1, BCL2A1, VNN1, TDRD9, SOCS3, CRTAP, CD86, TNFRSF6, LDLR, CSF1R, PRV1, IL18R1, INSL3, GADD45B, TNFSF13B, PFKFB3, JAK2, SOD2	0.82	0.8	0.84
SOD2, ARG2, HLA-DRA, LY96, Gene_MMP9, VNN1, CD86, IL10alpha, CSF1R, PSTPIP2, JAK2, TNFSF13B, IRAK2, CCL5, ANKRD22, TLR4, IL1RN, OSM, GADD45B	0.82	0.8	0.84
SOCS3, TGFB1, FCGR1A, TDRD9, GADD45A, TIFA, IFNGR1, VNN1, ITGAM, MAPK14, OSM, ANXA3, TNFSF13B, IL1RN, HLA-DRA, ARG2, MAP2K6, TLR4, PSTPIP2	0.82	0.78	0.86
CD86, INSL3, MAPK14, TIFA, MAP2K6, Gene_MMP9, CRTAP, CSF1R, MKNK1, IL10alpha, FAD104, PRV1, BCL2A1, NCR1, LDLR, IRAK4, HLA-DRA, IFNGR1, TDRD9	0.82	0.76	0.87
NCR1, LDLR, IRAK2, TNFRSF6, CD86, SOD2, TNFSF13B, VNN1, GADD45A, Gene_MMP9, PFKFB3, ANKRD22, PSTPIP2, PRV1, FCGR1A, IL18R1, TIFA, INSL3, CRTAP	0.82	0.74	0.89
IL1RN, TLR4, PSTPIP2, IL18R1, GADD45A, IL10alpha, BCL2A1, MKNK1, IRAK2, HLA-DRA, ANKRD22, NCR1, CEACAM1, LRAK4, OSM, TIFA, SOD2, TGFB1, Gene_MMP9	0.82	0.82	0.82
GADD45A, LY96, ITGAM, CCL5, TNFSF10, TNFSF13B, HLA-DRA, CSF1R, TIFA, SOCS3, MKNK1, ARG2, IFNGR1, IL1RN, BCL2A1, OSM, PFKFB3, PSTPIP2, IRAK2	0.82	0.78	0.85

TABLE L-continued

Exemplary sets of biomarkers used in the methods or kits referenced in Sections 5.2 and 5.3			
BIOMARKER SET	ACCURACY	SPECIFICITY	SENSISTIVITY
Gene_MMP9, GADD45A, PSTPIP2, INSL3, IRAK4, HLA-DRA, CCL5, TGFBI, OSM, LY96, TDRD9, NCR1, PFKFB3, IFNGR1, IRAK2, VNN1, CRTAP, TIFA, CD86	0.82	0.78	0.85
LDLR, ARG2, MAP2K6, MAPK14, IL18R1, CCL5, PSTPIP2, ANKRD22, OSM, TDRD9, HLA-DRA, SOCS3, ANXA3, TNFRSF6, TIFA, CD86, FAD104, MKNK1, BCL2A1, IRAK2	0.85	0.81	0.9
FCGR1A, FAD104, Gene_MMP9, LDLR, ANKRD22, VNN1, SOCS3, TNFSF13B, TLR4, TDRD9, CEACAM1, PSTPIP2, MAPK14, ARG2, IRAK4, OSM, PRV1, TNFRSF6, IL10alpha, PFKFB3	0.85	0.8	0.88
TNFSF10, IRAK2, TDRD9, TGFBI, PFKFB3, CD86, OSM, IFNGR1, FAD104, ANXA3, CCL5, IRAK4, PSTPIP2, GADD45A, SOCS3, CSF1R, NCR1, CRTAP, IL1RN, BCL2A1	0.84	0.8	0.88
IFNGR1, TIFA, ARG2, IRAK2, CCL5, LDLR, OSM, SOCS3, SOD2, IL1RN, PSTPIP2, BCL2A1, FAD104, IL18R1, IL10alpha, CD86, FCGR1A, ITGAM, JAK2, Gene_MMP9	0.84	0.83	0.85
PSTPIP2, SOCS3, OSM, FCGR1A, IL1RN, IRAK4, ITGAM, ARG2, TGFBI, Gene_MMP9, CSF1R, TLR4, GADD45A, GADD45B, PRV1, IFNGR1, IL18R1, VNN1, FAD104, PFKFB3	0.84	0.82	0.85
TNFRSF6, TIFA, PFKFB3, PRV1, OSM, JAK2, TGFBI, IL10alpha, CEACAM1, INSL3, IRAK2, LY96, ARG2, CD86, FAD104, MAP2K6, TLR4, SOCS3, IL18R1, ITGAM	0.84	0.8	0.87
FCGR1A, HLA-DRA, ARG2, CRTAP, CEACAM1, TNFSF13B, OSM, ANXA3, IL1RN, Gene_MMP9, TNFRSF6, FAD104, JAK2, IFNGR1, MKNK1, LDLR, IL10alpha, TGFBI, SOD2, CCL5	0.84	0.83	0.84
GADD45A, MAPK14, ARG2, TDRD9, NCR1, IL18R1, SOD2, ITGAM, FCGR1A, SOCS3, HLA-DRA, IRAK4, TNFRSF6, PRV1, CD86, TGFBI, TNFSF13B, TIFA, VNN1, FAD104	0.84	0.83	0.85
HLA-DRA, ARG2, IL1RN, SOCS3, PSTPIP2, CCL5, IFNGR1, CD86, TLR4, TGFBI, LY96, TNFRSF6, OSM, MAP2K6, VNN1, ITGAM, TNFSF10, NCR1, IRAK4, MAPK14	0.84	0.79	0.88
BCL2A1, ITGAM, ANKRD22, ARG2, FAD104, OSM, GADD45A, CCL5, TGFBI, CD86, PSTPIP2, PFKFB3, IFNGR1, IL18R1, CEACAM1, Gene_MMP9, IRAK2, IL1RN, NCR1, LY96	0.84	0.79	0.87
JAK2, VNN1, CSF1R, TLR4, OSM, SOCS3, ANXA3, LY96, MKNK1, TDRD9, ITGAM, Gene_MMP9, TGFBI, CEACAM1, CD86, MAP2K6, CCL5, TNFSF10, IL1RN, IL18R1	0.84	0.79	0.88
FAD104, PSTPIP2, CEACAM1, MAP2K6, TIFA, ANKRD22, INSL3, TLR4, CRTAP, LY96, SOCS3, MAPK14, JAK2, ARG2, MKNK1, IL18R1, CSF1R, CD86, PRV1, OSM	0.83	0.84	0.83
CEACAM1, SOCS3, FCGR1A, ARG2, INSL3, FAD104, IRAK4, GADD45A, ITGAM, PRV1, TNFSF13B, NCR1, Gene_MMP9, IL18R1, SOD2, MAPK14, TIFA, IRAK2, ANKRD22, IL1RN	0.83	0.8	0.87
GADD45B, SOD2, CRTAP, OSM, TNFSF13B, CCL5, CD86, INSL3, HLA-DRA, TNFRSF6, TGFBI, GADD45A, FCGR1A, FAD104, JAK2, IL1RN, PFKFB3, MAP2K6, CEACAM1, TDRD9	0.83	0.78	0.88

TABLE L-continued

Exemplary sets of biomarkers used in the methods or kits referenced in Sections 5.2 and 5.3			
BIOMARKER SET	ACCURACY	SPECIFICITY	SENSISTIVITY
FCGR1A, GADD45A, ANKRD22, IL1RN, PFKFB3, CCL5, TIFA, IL10alpha, CRTAP, MKNK1, PSTPIP2, PRV1, CSF1R, ANXA3, NCR1, JAK2, VNN1, IRAK4, CD86, MAP2K6	0.83	0.78	0.88
TLR4, GADD45A, JAK2, OSM, CD86, SOCS3, CEACAM1, IL18R1, MAP2K6, PRV1, FAD104, BCL2A1, VNN1, INSL3, PSTPIP2, ANKRD22, TNFSF10, IFNGR1, CRTAP, HLA-DRA	0.83	0.78	0.88
FAD104, IL18R1, TIFA, TNFRSF6, Gene_MMP9, ARG2, OSM, TNFSF13B, FCGR1A, CD86, CEACAM1, LY96, NCR1, TNFSF10, PFKFB3, PRV1, GADD45A, SOCS3, HLA-DRA, IRAK2	0.83	0.77	0.88
TDRD9, MKNK1, PFKFB3, IRAK2, INSL3, ITGAM, MAPK14, JAK2, HLA-DRA, CSF1R, CRTAP, NCR1, SOD2, TIFA, IRAK4, CD86, OSM, BCL2A1, LY96, ANKRD22	0.83	0.82	0.84
ANKRD22, CRTAP, NCR1, OSM, INSL3, CD86, CCL5, JAK2, CSF1R, GADD45B, ANXA3, SOCS3, PSTPIP2, FCGR1A, HLA-DRA, IRAK2, IL1RN, IL18R1, PFKFB3, Gene_MMP9	0.83	0.82	0.84
IL1RN, LY96, ARG2, PRV1, GADD45A, TNFSF10, FCGR1A, IL10alpha, LDLR, PFKFB3, CRTAP, SOD2, CEACAM1, IL18R1, CCL5, PSTPIP2, TLR4, VNN1, HLA-DRA, JAK2, ANKRD22	0.85	0.84	0.85
CD86, LDLR, CRTAP, OSM, TGFBI, FCGR1A, NCR1, MAPK14, GADD45A, ARG2, TLR4, GADD45B, INSL3, TNFSF10, ANXA3, MKNK1, PSTPIP2, CSF1R, SOD2, MAP2K6, BCL2A1	0.84	0.88	0.82
IRAK4, GADD45A, MAP2K6, ANKRD22, Gene_MMP9, TDRD9, PSTPIP2, VNN1, IL18R1, ARG2, IL1RN, PFKFB3, FCGR1A, TNFRSF6, JAK2, NCR1, TLR4, FAD104, SOCS3, IFNGR1, SOD2	0.84	0.82	0.85
SOCS3, ITGAM, Gene_MMP9, MKNK1, ARG2, CRTAP, BCL2A1, PRV1, NCR1, HLA-DRA, MAP2K6, FCGR1A, CD86, FAD104, CCL5, TGFBI, TDRD9, OSM, GADD45B, IRAK4, LY96	0.84	0.82	0.86
INSL3, BCL2A1, PSTPIP2, OSM, MAP2K6, CCL5, MKNK1, FAD104, ITGAM, MAPK14, IL1RN, VNN1, IRAK2, FCGR1A, CD86, PFKFB3, TDRD9, HLA-DRA, ARG2, TLR4, CEACAM1	0.83	0.84	0.83
TIFA, MKNK1, TNFSF13B, CSF1R, HLA-DRA, IL18R1, MAPK14, INSL3, PFKFB3, ANKRD22, LDLR, ARG2, CCL5, LY96, PSTPIP2, GADD45A, CEACAM1, JAK2, TGFBI, VNN1, IL1RN	0.83	0.82	0.84
CRTAP, FAD104, TIFA, BCL2A1, IRAK2, PSTPIP2, PFKFB3, MKNK1, ANKRD22, IL18R1, GADD45B, TDRD9, TLR4, INSL3, CEACAM1, MAP2K6, ARG2, CD86, NCR1, TNFSF13B, PRV1	0.83	0.81	0.85
JAK2, SOCS3, IFNGR1, IL1RN, OSM, BCL2A1, SOD2, ITGAM, FAD104, IL18R1, PSTPIP2, ARG2, PRV1, TNFSF13B, FCGR1A, IRAK2, IL10alpha, PFKFB3, MAPK14, INSL3, TGFBI	0.83	0.81	0.85
GADD45A, CCL5, LDLR, ARG2, IRAK2, SOCS3, SOD2, PRV1, MAP2K6, INSL3, TNFSF10, IL18R1, IL1RN, MAPK14, FAD104, IFNGR1, HLA-DRA, PSTPIP2, ITGAM, CSF1R, IL10alpha	0.83	0.86	0.8
CD86, TGFBI, ITGAM, IL10alpha, JAK2, TIFA, FAD104, CRTAP, IL1RN, BCL2A1,	0.83	0.79	0.86

TABLE L-continued

Exemplary sets of biomarkers used in the methods or kits referenced in Sections 5.2 and 5.3			
BIOMARKER SET	ACCURACY	SPECIFICITY	SENSISTIVITY
CCL5, GADD45B, HLA-DRA, SOD2, OSM, NCR1, VNN1, IL18R1, ANXA3, Gene_MMP9, PSTPIP2			
IL10alpha, TNFSF13B, GADD45B, MAP2K6, CCL5, IRAK2, MKNK1, LDLR, VNN1, GADD45A, ARG2, OSM, IFNGR1, IL18R1, ANKRD22, JAK2, TLR4, TGFBI, TNFRSF6, FAD104, PFKFB3	0.83	0.76	0.89
MAPK14, SOD2, PRV1, GADD45B, MKNK1, IL18R1, INSL3, NCR1, LY96, IRAK2, CSF1R, TNFRSF6, HLA-DRA, VNN1, IRAK4, FAD104, CEACAM1, IFNGR1, FCGR1A, TIFA, CD86	0.83	0.83	0.82
IL1RN, PFKFB3, IL18R1, PRV1, CRTAP, ITGAM, TNFRSF6, IL10alpha, SOCS3, VNN1, BCL2A1, MAPK14, GADD45A, IRAK2, CCL5, ARG2, TLR4, CD86, ANKRD22, TNFSF10, TGFBI	0.83	0.81	0.84
HLA-DRA, PRV1, GADD45A, IL1RN, IL18R1, TNFRSF6, LDLR, IRAK4, BCL2A1, TIFA, PSTPIP2, SOCS3, IL10alpha, FAD104, MKNK1, TNFSF13B, JAK2, TDRD9, TNFSF10, FCGR1A, CD86	0.83	0.81	0.84
INSL3, GADD45A, TGFBI, JAK2, IRAK2, OSM, TIFA, TNFSF13B, HLA-DRA, FCGR1A, BCL2A1, PRV1, CEACAM1, SOCS3, MAPK14, IRAK4, ANXA3, TNFRSF6, FAD104, IFNGR1, Gene_MMP9	0.82	0.82	0.82
BCL2A1, ANKRD22, IL10alpha, HLA-DRA, VNN1, GADD45B, TNFRSF6, CSF1R, IRAK4, ITGAM, IL1RN, IRAK2, LY96, MAPK14, JAK2, Gene_MMP9, TLR4, ARG2, CCL5, SOCS3, MAP2K6	0.82	0.8	0.84
TDRD9, VNN1, GADD45A, ANKRD22, PFKFB3, TNFSF13B, SOCS3, IL18R1, IL1RN, ARG2, CSF1R, HLA-DRA, PRV1, CEACAM1, CD86, IFNGR1, CCL5, MAP2K6, TGFBI, IL10alpha, Gene_MMP9	0.82	0.79	0.85
CRTAP, IL1RN, TIFA, IRAK4, ANXA3, SOCS3, CD86, CSF1R, FCGR1A, FAD104, ANKRD22, TNFSF13B, PSTPIP2, TDRD9, ARG2, TGFBI, Gene_MMP9, CCL5, IL10alpha, GADD45B, TNFRSF6	0.82	0.78	0.86
ANXA3, TNFRSF6, TDRD9, IRAK2, MAP2K6, INSL3, FCGR1A, GADD45A, NCR1, ARG2, VNN1, PRV1, MAPK14, IRAK4, SOCS3, ITGAM, HLA-DRA, CD86, CEACAM1, LY96, GADD45B	0.82	0.78	0.87
VNN1, CCL5, IFNGR1, LY96, IL10alpha, ITGAM, FCGR1A, FAD104, NCR1, TNFRSF6, TNFSF13B, SOCS3, TIFA, TNFSF10, PSTPIP2, ARG2, IL18R1, CSF1R, OSM, PFKFB3, LDLR, IRAK2	0.87	0.84	0.89
IL18R1, GADD45A, BCL2A1, HLA-DRA, PSTPIP2, ANKRD22, CRTAP, FAD104, CD86, TNFRSF6, Gene_MMP9, IRAK2, SOD2, IL10alpha, IFNGR1, FCGR1A, TIFA, OSM, CCL5, GADD45B, TGFBI, TLR4	0.84	0.79	0.88
TNFSF13B, LDLR, GADD45B, MAPK14, PFKFB3, CRTAP, MAP2K6, NCR1, CCL5, ARG2, SOD2, BCL2A1, MKNK1, TIFA, ANKRD22, Gene_MMP9, TGFBI, IL1RN, HLA-DRA, IL18R1, VNN1, CSF1R	0.84	0.79	0.89
TNFRSF6, PSTPIP2, CD86, VNN1, CCL5, MAPK14, TLR4, BCL2A1, ANKRD22, ARG2, ITGAM, IL10alpha, IRAK4, SOCS3, LY96, CRTAP, JAK2, IL1RN, FCGR1A, MAP2K6, TNFSF10, GADD45A	0.83	0.85	0.82
TDRD9, CRTAP, ANKRD22, TNFSF13B, ANXA3, CCL5, FCGR1A, TNFSF10, TNFRSF6, PRV1, IRAK2, CEACAM1,	0.83	0.82	0.85

TABLE L-continued

Exemplary sets of biomarkers used in the methods or kits referenced in Sections 5.2 and 5.3			
BIOMARKER SET	ACCURACY	SPECIFICITY	SENSISTIVITY
SOCS3, CSF1R, FAD104, PSTPIP2, VNN1, ARG2, IL1RN, HLA-DRA, BCL2A1, INSL3, TNFSF10, TLR4, MAP2K6, PFKFB3, FCGR1A, INSL3, MAPK14, PSTPIP2, IFNGR1, CD86, PRV1, IL10alpha, OSM, FAD104, ITGAM, ANXA3, TIFA, CEACAM1, IL18R1, TNFRSF6, NCR1, GADD45A	0.83	0.79	0.86
GADD45B, HLA-DRA, NCR1, TGFBI, OSM, MKNK1, TLR4, ARG2, CCL5, LDLR, IFNGR1, SOCS3, INSL3, TIFA, TNFSF10, CD86, IL10alpha, GADD45A, CSF1R, TDRD9, BCL2A1, ANXA3	0.83	0.8	0.86
TLR4, ANXA3, IL10alpha, NCR1, JAK2, TNFSF13B, GADD45A, OSM, SOCS3, CEACAM1, BCL2A1, MKNK1, ARG2, CRTAP, TNFRSF6, Gene_MMP9, PSTPIP2, SOD2, CD86, IL1RN, FCGR1A, CSF1R	0.83	0.76	0.88
LY96, TIFA, TLR4, PSTPIP2, Gene_MMP9, PRV1, HLA-DRA, CEACAM1, FCGR1A, ARG2, IRAK4, IL1RN, OSM, IFNGR1, TNFSF13B, CSF1R, TDRD9, GADD45B, ANXA3, SOCS3, GADD45A, LDLR	0.83	0.82	0.83
INSL3, PSTPIP2, MKNK1, FCGR1A, PFKFB3, OSM, TGFBI, MAPK14, IRAK2, GADD45A, ANKRD22, CCL5, HLA-DRA, IL10alpha, SOCS3, CD86, IFNGR1, ARG2, Gene_MMP9, GADD45B, VNN1, IL1RN	0.83	0.82	0.83
IL1RN, IFNGR1, CCL5, GADD45B, VNN1, CSF1R, TNFSF10, LDLR, TNFRSF6, INSL3, CD86, OSM, FCGR1A, BCL2A1, CRTAP, TLR4, NCR1, PSTPIP2, SOCS3, MAP2K6, TNFSF13B, Gene_MMP9	0.83	0.78	0.87
ARG2, GADD45B, TNFSF10, IRAK2, MAPK14, IL1RN, MKNK1, CRTAP, TNFSF13B, PRV1, SOD2, VNN1, IL18R1, HLA-DRA, MAP2K6, INSL3, CEACAM1, IL10alpha, LY96, SOCS3, FCGR1A, ANKRD22	0.82	0.83	0.82
IFNGR1, LDLR, ITGAM, VNN1, IL18R1, TGFBI, SOCS3, ANKRD22, HLA-DRA, TIFA, OSM, TLR4, IRAK4, INSL3, SOD2, TNFSF13B, LY96, IRAK2, BCL2A1, MAPK14, CCL5, MKNK1	0.82	0.83	0.82
Gene_MMP9, BCL2A1, TDRD9, OSM, MAPK14, IRAK2, CRTAP, MAP2K6, TGFBI, IL18R1, TNFSF10, ANXA3, IFNGR1, GADD45A, TIFA, PSTPIP2, SOCS3, ITGAM, ARG2, HLA-DRA, FAD104, IRAK4	0.82	0.81	0.83
IRAK2, IL1RN, ITGAM, LY96, IFNGR1, TGFBI, TIFA, PFKFB3, Gene_MMP9, FAD104, TNFSF13B, VNN1, LDLR, INSL3, HLA-DRA, NCR1, TDRD9, TNFRSF6, ANXA3, CSF1R, SOCS3, IL18R1	0.82	0.81	0.84
TNFRSF6, INSL3, LDLR, CD86, TGFBI, NCR1, Gene_MMP9, CRTAP, HLA-DRA, BCL2A1, MKNK1, IL18R1, TLR4, CEACAM1, PRV1, CCL5, OSM, TDRD9, PFKFB3, IFNGR1, IRAK2, PSTPIP2	0.82	0.8	0.84
PFKFB3, ITGAM, ANKRD22, MAPK14, TGFBI, PSTPIP2, BCL2A1, IFNGR1, MKNK1, NCR1, ARG2, HLA-DRA, INSL3, CRTAP, FCGR1A, LDLR, CCL5, JAK2, IRAK4, TLR4, LY96, IL10alpha	0.82	0.8	0.85
TIFA, IFNGR1, HLA-DRA, Gene_MMP9, PRV1, FAD104, IL10alpha, GADD45B, IRAK4, IL1RN, TDRD9, IL18R1, BCL2A1, CD86, GADD45A, CCL5, ANXA3, OSM, SOCS3, PFKFB3, LDLR, CSF1R	0.82	0.8	0.84
FAD104, NCR1, BCL2A1, IRAK2, TLR4, IL18R1, SOD2, MAPK14, GADD45B, CD86,	0.82	0.8	0.84

TABLE L-continued

Exemplary sets of biomarkers used in the methods or kits referenced in Sections 5.2 and 5.3			
BIOMARKER SET	ACCURACY	SPECIFICITY	SENSISTIVITY
FCGR1A, CSF1R, OSM, MAP2K6, PFKFB3, LY96, TIFA, MKNK1, PSTPIP2, CRTAP, TGFBI, GADD45A	0.85	0.81	0.89
GADD45A, CSF1R, IL18R1, TGFBI, TNFSF13B, ANXA3, OSM, SOCS3, LY96, TDRD9, ITGAM, FCGR1A, IFNGR1, FAD104, HLA-DRA, PSTPIP2, MKNK1, CRTAP, GADD45B, Gene_MMP9, LDLR, TLR4, VNN1	0.85	0.82	0.87
MAP2K6, TGFBI, HLA-DRA, IL10alpha, VNN1, GADD45B, CEACAM1, PRV1, OSM, IRAK4, IRAK2, ITGAM, CSF1R, TDRD9, NCR1, TNFSF13B, CRTAP, BCL2A1, TIFA, IFNGR1, GADD45A, IL18R1, SOD2	0.84	0.83	0.85
GADD45B, MAPK14, TDRD9, CCL5, OSM, TNFSF13B, ANXA3, TIFA, ANKRD22, TNFRSF6, TNFSF10, PSTPIP2, TLR4, VNN1, FCGR1A, IL18R1, NCR1, GADD45A, LY96, INSL3, ITGAM, BCL2A1, IRAK2	0.84	0.8	0.88
HLA-DRA, PFKFB3, IRAK4, MKNK1, TGFBI, CRTAP, ANXA3, CEACAM1, CCL5, JAK2, TNFSF10, IL1RN, CSF1R, IFNGR1, ARG2, LY96, Gene_MMP9, PRV1, CD86, IRAK2, ITGAM, IL10alpha, OSM	0.84	0.8	0.89
FAD104, LY96, NCR1, TLR4, TNFSF13B, MAPK14, MAP2K6, HLA-DRA, FCGR1A, CD86, ANKRD22, LDLR, IL1RN, IFNGR1, TDRD9, TGFBI, GADD45A, PRV1, PFKFB3, ITGAM, JAK2, PSTPIP2, CRTAP	0.84	0.82	0.85
BCL2A1, FCGR1A, CRTAP, Gene_MMP9, TDRD9, CEACAM1, SOCS3, SOD2, LDLR, GADD45B, LY96, CSF1R, ARG2, TNFRSF6, PSTPIP2, PFKFB3, IL1RN, IL10alpha, VNN1, GADD45A, INSL3, JAK2, IFNGR1	0.84	0.82	0.86
Gene_MMP9, LDLR, CEACAM1, MAPK14, TLR4, ANXA3, IRAK4, FCGR1A, GADD45B, GADD45A, TGFBI, BCL2A1, CSF1R, PRV1, TNFRSF6, IFNGR1, TDRD9, LY96, MAP2K6, OSM, CRTAP, CD86, FAD104	0.83	0.82	0.84
FCGR1A, ANXA3, MAPK14, TNFRSF6, PSTPIP2, INSL3, ANKRD22, CD86, CRTAP, FAD104, GADD45B, IL18R1, TLR4, IRAK2, ITGAM, JAK2, GADD45A, BCL2A1, IFNGR1, CSF1R, TIFA, NCR1, IRAK4	0.83	0.8	0.85
CRTAP, OSM, TNFRSF6, IRAK2, VNN1, IRAK4, ANXA3, SOD2, ANKRD22, ITGAM, TLR4, MKNK1, IL18R1, CEACAM1, TGFBI, PRV1, Gene_MMP9, TNFSF13B, BCL2A1, HLA-DRA, INSL3, NCR1, CSF1R	0.83	0.79	0.87
FAD104, CEACAM1, CCL5, PSTPIP2, TNFSF10, VNN1, CRTAP, IRAK2, FCGR1A, TNFSF13B, CD86, IL10alpha, ARG2, BCL2A1, IFNGR1, PRV1, IL18R1, TNFRSF6, TIFA, TLR4, JAK2, MAPK14, MAP2K6	0.83	0.84	0.81
ARG2, MAPK14, IRAK4, LDLR, IL10alpha, Gene_MMP9, NCR1, OSM, CEACAM1, SOD2, CSF1R, CCL5, GADD45A, ITGAM, BCL2A1, HLA-DRA, PFKFB3, TNFSF13B, TNFSF10, IRAK2, VNN1, JAK2, PRV1	0.83	0.83	0.83
FAD104, IFNGR1, INSL3, PFKFB3, MAP2K6, LDLR, CD86, ARG2, PRV1, IL1RN, OSM, ITGAM, VNN1, MKNK1, ANXA3, JAK2, GADD45B, CSF1R, TNFSF13B, PSTPIP2, FCGR1A, CRTAP, TGFBI	0.83	0.77	0.89
VNN1, SOCS3, ANKRD22, FAD104, IL18R1, OSM, ITGAM, CCL5, TGFBI, MAPK14, MKNK1, HLA-DRA, LDLR, PSTPIP2, ARG2, CSF1R, IL10alpha, MAP2K6, LY96, FCGR1A, TNFSF10, JAK2, TLR4			

TABLE L-continued

Exemplary sets of biomarkers used in the methods or kits referenced in Sections 5.2 and 5.3			
BIOMARKER SET	ACCURACY	SPECIFICITY	SENSISTIVITY
CEACAM1, MAP2K6, IL18R1, TIFA, HLA-DRA, FAD104, TGFBI, LDLR, ANKRD22, IL1RN, SOCS3, TNFSF13B, NCR1, CD86, BCL2A1, IL10alpha, TLR4, CRTAP, MKNK1, ITGAM, JAK2, OSM, ARG2	0.82	0.82	0.83
VNN1, FCGR1A, SOD2, CRTAP, TGFBI, LDLR, FAD104, NCR1, TNFRSF6, ARG2, GADD45A, OSM, ANXA3, ITGAM, BCL2A1, CSF1R, IFNGR1, TIFA, CEACAM1, CCL5, SOCS3, ANKRD22, Gene_MMP9	0.82	0.81	0.84
CCL5, IL1RN, TIFA, PRV1, TNFSF13B, INSL3, IRAK2, MKNK1, MAPK14, FCGR1A, SOCS3, JAK2, FAD104, IFNGR1, CRTAP, IL18R1, GADD45B, SOD2, TNFSF10, HLA-DRA, TNFRSF6, ANKRD22, LDLR	0.82	0.81	0.84
PRV1, BCL2A1, SOD2, VNN1, FAD104, TIFA, IL10alpha, SOCS3, ITGAM, IL18R1, CEACAM1, MAP2K6, TNFSF13B, JAK2, IRAK4, TNFRSF6, OSM, CRTAP, PSTPIP2, TLR4, CSF1R, IL1RN, FCGR1A	0.82	0.74	0.9
TNFRSF6, TNFSF10, CD86, IL10alpha, ARG2, TLR4, JAK2, MAP2K6, GADD45B, LDLR, TIFA, IRAK2, BCL2A1, SOD2, LY96, PFKFB3, HLA-DRA, CSF1R, FAD104, CRTAP, FCGR1A, ANXA3, SOCS3	0.82	0.81	0.83
TNFSF13B, IRAK4, CD86, LDLR, OSM, CCL5, ANXA3, IL1RN, GADD45B, SOCS3, TGFBI, BCL2A1, FAD104, IRAK2, IL10alpha, NCR1, MAP2K6, INSL3, TIFA, CEACAM1, MKNK1, MAPK14, JAK2	0.82	0.8	0.83
LY96, ANXA3, TIFA, CSF1R, GADD45B, PFKFB3, IL1RN, IL18R1, LDLR, TNFRSF6, OSM, INSL3, CRTAP, MAP2K6, IRAK2, ARG2, IL10alpha, NCR1, FAD104, IRAK4, MKNK1, VNN1, IFNGR1, SOD2	0.85	0.8	0.89
NCR1, IL1RN, PRV1, IL18R1, HLA-DRA, BCL2A1, GADD45A, FAD104, TLR4, OSM, FCGR1A, TNFSF10, CRTAP, INSL3, GADD45B, LY96, IRAK2, CD86, VNN1, CCL5, JAK2, IL10alpha, MKNK1, IRAK4	0.84	0.82	0.86
GADD45A, MKNK1, ANXA3, TLR4, MAP2K6, TIFA, FCGR1A, IRAK2, TDRD9, VNN1, CSF1R, GADD45B, LDLR, IL1RN, ANKRD22, JAK2, HLA-DRA, IL10alpha, PSTPIP2, Gene_MMP9, CRTAP, IL18R1, MAPK14, ARG2	0.84	0.83	0.85
FAD104, IL18R1, IRAK2, TIFA, IL10alpha, ITGAM, SOCS3, TDRD9, PSTPIP2, ARG2, INSL3, IL1RN, TLR4, IFNGR1, VNN1, MAPK14, TNFRSF6, SOD2, ANKRD22, NCR1, ANXA3, FCGR1A, CD86, OSM	0.83	0.83	0.84
TLR4, TGFBI, CEACAM1, OSM, CRTAP, IL1RN, TNFRSF6, PRV1, SOD2, MKNK1, VNN1, CSF1R, IL18R1, ANKRD22, MAPK14, ANXA3, TNFSF10, TDRD9, BCL2A1, IRAK4, FCGR1A, CCL5, TNFSF13B, GADD45B	0.83	0.83	0.83
ARG2, JAK2, CSF1R, NCR1, LY96, HLA-DRA, ANXA3, PSTPIP2, IRAK4, BCL2A1, IL1RN, IFNGR1, FCGR1A, VNN1, TNFSF10, MAPK14, TGFBI, GADD45B, INSL3, IRAK2, OSM, CD86, CRTAP, TNFSF13B	0.83	0.82	0.84
HLA-DRA, INSL3, PRV1, MAP2K6, TIFA, NCR1, CSF1R, TDRD9, IL18R1, MKNK1, TNFRSF6, TNFSF10, LDLR, IRAK4, FAD104, ITGAM, PSTPIP2, MAPK14, TNFSF13B, GADD45B, CEACAM1, IL1RN, ANXA3, PFKFB3	0.83	0.81	0.84

TABLE L-continued

Exemplary sets of biomarkers used in the methods or kits referenced in Sections 5.2 and 5.3			
BIOMARKER SET	ACCURACY	SPECIFICITY	SENSISTIVITY
INSL3, TDRD9, GADD45A, BCL2A1, PFKFB3, TNFRSF6, MAP2K6, GADD45B, TGFB1, IRAK2, CEACAM1, ITGAM, IL10alpha, ANXA3, JAK2, IL1RN, CRTAP, PRV1, SOCS3, TIFA, CCL5, LY96, TNFSF10, OSM	0.83	0.78	0.87
VNN1, LDLR, FAD104, HLA-DRA, ARG2, IFNGR1, IRAK4, TNFRSF6, TIFA, MAP2K6, NCR1, OSM, PRV1, CSF1R, INSL3, TNFSF13B, JAK2, MAPK14, BCL2A1, IRAK2, TLR4, PSTPIP2, TDRD9, ANXA3	0.82	0.85	0.8
ANXA3, TNFSF10, TGFB1, MKNK1, PSTPIP2, GADD45A, CRTAP, LDLR, INSL3, MAPK14, IFNGR1, BCL2A1, TNFSF13B, GADD45B, Gene_MMP9, IRAK2, CEACAM1, PRV1, SOD2, FAD104, JAK2, NCR1, ARG2, IL1RN	0.82	0.83	0.82
TDRD9, LY96, PFKFB3, IRAK2, FAD104, NCR1, Gene_MMP9, MAPK14, CCL5, LDLR, PSTPIP2, OSM, VNN1, IRAK4, BCL2A1, TIFA, GADD45A, TGFB1, ANKRD22, FCGR1A, IFNGR1, ARG2, CD86, IL18R1	0.82	0.8	0.85
CD86, TNFSF13B, PSTPIP2, IL10alpha, HLA-DRA, MAP2K6, FCGR1A, Gene_MMP9, JAK2, SOCS3, CSF1R, TDRD9, ARG2, NCR1, OSM, FAD104, BCL2A1, TNFRSF6, INSL3, VNN1, ITGAM, PRV1, TLR4, CEACAM1	0.82	0.8	0.84
IL18R1, ARG2, VNN1, TNFRSF6, TIFA, MKNK1, IL10alpha, CD86, NCR1, OSM, ANKRD22, TDRD9, PSTPIP2, ITGAM, IFNGR1, MAP2K6, BCL2A1, IRAK2, TLR4, LY96, SOCS3, GADD45B, IRAK4, PRV1	0.82	0.78	0.86
TNFSF10, ITGAM, MAP2K6, TIFA, CSF1R, TDRD9, FAD104, TLR4, GADD45B, HLA-DRA, IRAK2, IRAK4, OSM, FCGR1A, CCL5, SOD2, VNN1, MKNK1, ARG2, Gene_MMP9, TGFB1, TNFSF13B, MAPK14, PFKFB3	0.82	0.78	0.86
TNFSF10, CEACAM1, IFNGR1, TIFA, MKNK1, ANXA3, IL1RN, IL10alpha, IL18R1, HLA-DRA, SOCS3, Gene_MMP9, MAPK14, TGFB1, JAK2, IRAK2, TLR4, CSF1R, BCL2A1, PSTPIP2, MAP2K6, CD86, ITGAM, SOD2	0.82	0.75	0.88
SOD2, PFKFB3, MAP2K6, HLA-DRA, ANKRD22, IL18R1, Gene_MMP9, LDLR, ARG2, GADD45A, JAK2, MKNK1, PRV1, FCGR1A, ITGAM, OSM, NCR1, VNN1, LY96, IFNGR1, TIFA, PSTPIP2, IL1RN, TLR4	0.82	0.85	0.79
CSF1R, FCGR1A, IL18R1, ANKRD22, MKNK1, NCR1, IRAK2, TDRD9, GADD45A, CRTAP, GADD45B, JAK2, PRV1, SOCS3, CD86, MAPK14, MAP2K6, IFNGR1, LY96, FAD104, OSM, SOD2, TLR4, IL10alpha	0.82	0.81	0.83
ARG2, TGFB1, TIFA, IL18R1, TNFRSF6, CSF1R, CCL5, SOCS3, LY96, MKNK1, BCL2A1, SOD2, FCGR1A, PSTPIP2, GADD45B, IFNGR1, NCR1, TNFSF10, LDLR, PRV1, IL1RN, TDRD9, ANKRD22, TLR4	0.82	0.8	0.83
IL1RN, IL10alpha, IFNGR1, TDRD9, PFKFB3, GADD45B, TNFSF10, PSTPIP2, SOCS3, TIFA, MAPK14, CSF1R, TNFSF13B, CRTAP, TNFRSF6, ARG2, IL18R1, LY96, TGFB1, CD86, TLR4, GADD45A, OSM, Gene_MMP9	0.82	0.8	0.84
SOD2, IRAK4, SOCS3, VNN1, IL1RN, ITGAM, TNFSF10, GADD45A, CCL5,	0.86	0.88	0.85

TABLE L-continued

Exemplary sets of biomarkers used in the methods or kits referenced in Sections 5.2 and 5.3			
BIOMARKER SET	ACCURACY	SPECIFICITY	SENSISTIVITY
CEACAM1, ANKRD22, NCR1, IL18R1, OSM, ARG2, INSL3, MAPK14, MAP2K6, TGFBI, TNFSF13B, PFKFB3, MKNK1, LY96, FCGR1A, CSF1R			
LDLR, VNN1, GADD45A, SOCS3, TLR4, SOD2, BCL2A1, IL18R1, IRAK2, HLA-DRA, TIFA, CEACAM1, OSM, INSL3, TNFSF13B, TNFRSF6, Gene_MMP9, CRTAP, ARG2, LY96, GADD45B, CSF1R, FCGR1A, IL1RN, PFKFB3	0.85	0.85	0.85
ARG2, PRV1, TNFSF10, FAD104, SOD2, ANXA3, IL18R1, JAK2, LDLR, OSM, IFNGR1, PSTPIP2, TNFRSF6, IRAK4, IL1RN, VNN1, FCGR1A, ITGAM, IL10alpha, IRAK2, INSL3, CD86, TDRD9, TIFA, MKNK1	0.85	0.84	0.86
GADD45B, IRAK2, MAPK14, Gene_MMP9, CD86, CEACAM1, SOD2, SOCS3, ARG2, ANXA3, LDLR, JAK2, VNN1, IFNGR1, FAD104, NCR1, PRV1, OSM, TDRD9, MKNK1, ITGAM, INSL3, IL1RN, ANKRD22, CCL5	0.85	0.81	0.89
IL10alpha, IRAK2, HLA-DRA, Gene_MMP9, TGFBI, LDLR, TIFA, GADD45A, ARG2, CSF1R, MAP2K6, CEACAM1, PRV1, OSM, CD86, TNFRSF6, LY96, FAD104, PSTPIP2, ANXA3, IFNGR1, NCR1, CCL5, GADD45B, PFKFB3	0.84	0.85	0.84
GADD45A, SOCS3, SOD2, TGFBI, HLA-DRA, VNN1, CD86, CCL5, BCL2A1, CRTAP, MAP2K6, PRV1, IL18R1, CSF1R, OSM, IRAK2, PSTPIP2, TLR4, FCGR1A, ANKRD22, CEACAM1, JAK2, INSL3, TDRD9, TNFSF10	0.84	0.84	0.85
FCGR1A, TLR4, ANKRD22, CEACAM1, IRAK4, LY96, TDRD9, ARG2, CRTAP, ANXA3, LDLR, MAPK14, CD86, Gene_MMP9, INSL3, GADD45B, TNFSF10, VNN1, IRAK2, PSTPIP2, TIFA, TNFRSF6, TGFBI, IL18R1, IL1RN	0.84	0.78	0.9
SOCS3, VNN1, FCGR1A, SOD2, OSM, TNFSF10, LY96, Gene_MMP9, GADD45B, CRTAP, PRV1, HLA-DRA, GADD45A, TLR4, ARG2, IRAK2, FAD104, INSL3, PSTPIP2, TIFA, TGFBI, IL18R1, MAP2K6, LDLR, ANXA3	0.84	0.83	0.84
MAP2K6, LDLR, TIFA, TNFSF13B, IL18R1, ITGAM, SOCS3, OSM, ANXA3, GADD45A, Gene_MMP9, CD86, IL1RN, IFNGR1, PRV1, FCGR1A, MAPK14, CCL5, VNN1, ARG2, PSTPIP2, IRAK2, NCR1, TDRD9, TNFRSF6			
TIFA, ANKRD22, TNFSF13B, SOCS3, NCR1, IRAK4, JAK2, GADD45A, CCL5, LDLR, MAPK14, IL18R1, SOD2, TGFBI, CSF1R, IFNGR1, MAP2K6, TNFSF10, IRAK2, LY96, IL1RN, TNFRSF6, VNN1, INSL3, PFKFB3	0.84	0.82	0.86
MAP2K6, FAD104, CCL5, IL18R1, NCR1, VNN1, IL10alpha, ANKRD22, IFNGR1, MAPK14, CD86, MKNK1, TLR4, LY96, TIFA, PSTPIP2, TNFRSF6, LDLR, CSF1R, ARG2, TGFBI, JAK2, PFKFB3, OSM, TDRD9	0.84	0.81	0.86

TABLE L-continued

Exemplary sets of biomarkers used in the methods or kits referenced in Sections 5.2 and 5.3			
BIOMARKER SET	ACCURACY	SPECIFICITY	SENSISTIVITY
JAK2, OSM, IRAK4, VNN1, SOCS3, GADD45B, IL1RN, FCGR1A, TNFRSF6, Gene_MMP9, ANKRD22, ARG2, IL10alpha, CCL5, IL18R1, ANXA3, LY96, PSTPIP2, TIFA, TNFSF10, FAD104, MAP2K6, MKNK1, PFKFB3, CRTAP	0.83	0.84	0.83
TIFA, IRAK2, ANKRD22, CCL5, IL10alpha, INSL3, CEACAM1, TLR4, FCGR1A, NCR1, CD86, BCL2A1, GADD45A, ITGAM, MAP2K6, CRTAP, VNN1, TDRD9, SOCS3, ANXA3, TNFSF10, LY96, MKNK1, JAK2, ARG2	0.83	0.85	0.82
PSTPIP2, CEACAM1, FAD104, TIFA, ANKRD22, OSM, TNFSF13B, IRAK4, INSL3, GADD45A, IL10alpha, CSF1R, HLA-DRA, SOCS3, GADD45B, CCL5, Gene_MMP9, LY96, TLR4, IFNGR1, TGFBI, BCL2A1, MAP2K6, CD86, PFKFB3	0.83	0.82	0.84
IL1RN, JAK2, PFKFB3, OSM, CD86, IL18R1, SOD2, GADD45B, ITGAM, TNFRSF6, MAP2K6, LDLR, TLR4, TIFA, INSL3, SOCS3, IFNGR1, ANKRD22, GADD45A, IRAK4, CRTAP, CSF1R, TNFSF13B, PRV1, PSTPIP2	0.83	0.82	0.84
IFNGR1, VNN1, ANKRD22, FCGR1A, JAK2, MAP2K6, SOD2, TNFSF13B, IRAK4, CEACAM1, LY96, MAPK14, INSL3, NCR1, Gene_MMP9, CCL5, HLA-DRA, LDLR, TNFRSF6, PFKFB3, ANXA3, SOCS3, ARG2, ITGAM, CSF1R	0.83	0.78	0.87
LDLR, GADD45A, IFNGR1, ARG2, MAPK14, HLA-DRA, CRTAP, OSM, TDRD9, CSF1R, FCGR1A, Gene_MMP9, NCR1, PRV1, IRAK4, TGFBI, TLR4, LY96, IL1RN, FAD104, SOD2, CCL5, TNFRSF6, MAP2K6, TNFSF13B	0.83	0.83	0.82
IL18R1, IL1RN, IRAK4, CEACAM1, ITGAM, LY96, ANKRD22, ARG2, TDRD9, LDLR, NCR1, IL10alpha, ANXA3, CD86, MAPK14, TNFRSF6, SOD2, MKNK1, GADD45B, CRTAP, PFKFB3, CSF1R, INSL3, PSTPIP2, CCL5	0.83	0.83	0.83
PSTPIP2, NCR1, MKNK1, SOCS3, IL1RN, IFNGR1, IL18R1, CSF1R, ITGAM, LDLR, TIFA, CRTAP, OSM, TLR4, CEACAM1, Gene_MMP9, INSL3, MAP2K6, CCL5, FAD104, HLA-DRA, PRV1, VNN1, PFKFB3, JAK2	0.83	0.81	0.84

[0436] In some embodiments, the methods or kits respectively described or referenced in Section 5.2 and Section 5.3 use any one of the biomarker sets listed in Table M. The biomarker sets listed in Table M were identified in the computational experiments described in Section 6.14.2, below, in which 1600 random subcombinations of the biomarkers listed in Table K were tested. Table M lists some of the biomarker sets that provided high accuracy scores against the validation population described in Section 6.14.2. Each row of Table M lists a single biomarker set that can be used in the methods and kits respectively referenced in Sections 5.2 and 5.3. In other words, each row of Table M describes a biomarker set that can be used to discriminate between sepsis and SIRS subjects (e.g., to determine whether a subject is likely to acquire SEPSIS). In some embodiments, nucleic acid forms of the biomarkers listed in Table M are used in the methods and kits respectively referenced in Sections 5.2 and 5.3. In

some embodiments, protein forms of the biomarkers listed in Table M are used. In some hybrid embodiments, some of the biomarkers in a biomarker set from Table M are in protein form and some of the biomarkers in the same biomarker set from Table M are in nucleic acid form in the methods and kits respectively referenced in Sections 5.2 and 5.3.

[0437] In some embodiments, a given biomarker set listed in Table M is used with the addition of one, two, three, four, five, six, seven, eight, or nine or more additional biomarkers from Table I that are not within the given set of biomarkers from Table M. In some embodiments, a given set of biomarkers from Table M is used with the addition of one, two, three, four, five, six, seven, eight, or nine or more additional biomarkers from any one of Table 1, 30, 31, 32, 33, 34, or 36 that are not within the given biomarker set from Table M. In Table M, accuracy, specificity, and sensitivity are described with reference to T_{-12} time point data described in Section 6.14.2, below.

TABLE M

Exemplary sets of biomarkers used in the methods or kits referenced in Sections 5.2 and 5.3			
BIOMARKER SET	ACCURACY	SPECIFICITY	SENSISTIVITY
ALPHAFETOPROTEIN, IL6, IL8	0.78	0.76	0.8
CREACTIVEPROTEIN, TIMP1, IL6	0.78	0.75	0.8
PROTEIN_MMP9, IL8, IL6	0.77	0.8	0.74
IL8, IL6, IL10	0.77	0.72	0.81
CREACTIVEPROTEIN, IL6, PROTEIN_MMP9	0.77	0.77	0.76
APOLIPOPROTEINCIII, IL8, IL6	0.76	0.74	0.78
IL6, IL8, CREACTIONPROTEIN	0.76	0.74	0.79
ALPHAFETOPROTEIN, MCP1, IL10, IL6	0.8	0.8	0.8
ALPHAFETOPROTEIN, IL10, IL6, PROTEIN_MMP9	0.79	0.7	0.86
ALPHAFETOPROTEIN, PROTEIN_MMP9, IL6, APOLIPOPROTEINCIII	0.78	0.74	0.81
APOLIPOPROTEINCIII, IL6, BETA2MICROGLOBULIN, TIMP1	0.78	0.73	0.81
IL6, BETA2MICROGLOBULIN, IL10, APOLIPOPROTEINCIII	0.77	0.73	0.81
IL6, PROTEIN_MMP9, IL10, MCP1	0.77	0.81	0.73
APOLIPOPROTEINCIII, ALPHAFETOPROTEIN, PROTEIN_MMP9, IL6	0.77	0.78	0.75
IL10, TIMP1, IL6, ALPHAFETOPROTEIN	0.77	0.71	0.83
TIMP1, IL6, CREACTIONPROTEIN, BETA2MICROGLOBULIN	0.76	0.8	0.73
PROTEIN_MMP9, CREACTIONPROTEIN, MCP1, IL10, IL6	0.8	0.78	0.81
APOLIPOPROTEINCIII, CREACTIONPROTEIN, IL10, ALPHAFETOPROTEIN, IL6	0.79	0.81	0.78
CREACTIONPROTEIN, ALPHAFETOPROTEIN, IL6, PROTEIN_MMP9, IL8	0.79	0.77	0.81
IL6, TIMP1, MCP1, APOLIPOPROTEINCIII, CREACTIONPROTEIN	0.78	0.75	0.82
CREACTIONPROTEIN, APOLIPOPROTEINCIII, TIMP1, IL8, PROTEIN_MMP9	0.78	0.79	0.76
CREACTIONPROTEIN, IL10, MCP1, IL6, TIMP1	0.77	0.78	0.77
IL10, IL8, APOLIPOPROTEINCIII, IL6, TIMP1	0.77	0.73	0.8
IL10, CREACTIONPROTEIN, MCP1, IL6, APOLIPOPROTEINCIII	0.77	0.72	0.82
IL6, ALPHAFETOPROTEIN, IL8, CREACTIONPROTEIN, TIMP1	0.77	0.75	0.78
TIMP1, MCP1, PROTEIN_MMP9, IL6, APOLIPOPROTEINCIII, CREACTIONPROTEIN	0.8	0.81	0.79
TIMP1, IL6, IL10, CREACTIONPROTEIN, APOLIPOPROTEINCIII, PROTEIN_MMP9	0.79	0.77	0.8
MCP1, PROTEIN_MMP9, APOLIPOPROTEINCIII, IL6, TIMP1, IL10	0.79	0.75	0.82
IL10, CREACTIONPROTEIN, IL6, ALPHAFETOPROTEIN, TIMP1, PROTEIN_MMP9	0.78	0.78	0.79
PROTEIN_MMP9, CREACTIONPROTEIN, ALPHAFETOPROTEIN, IL10, IL6, MCP1	0.78	0.77	0.79
IL6, MCP1, IL10, TIMP1, APOLIPOPROTEINCIII, IL8	0.78	0.76	0.79
TIMP1, IL6, IL10, BETA2MICROGLOBULIN, PROTEIN_MMP9, APOLIPOPROTEINCIII	0.77	0.72	0.83
IL10, MCP1, ALPHAFETOPROTEIN, APOLIPOPROTEINCIII, IL6, PROTEIN_MMP9	0.77	0.76	0.78
BETA2MICROGLOBULIN, IL6, TIMP1, ALPHAFETOPROTEIN, CREACTIONPROTEIN, PROTEIN_MMP9	0.77	0.74	0.79

TABLE M-continued

Exemplary sets of biomarkers used in the methods or kits referenced in Sections 5.2 and 5.3			
BIOMARKER SET	ACCURACY	SPECIFICITY	SENSISTIVITY
MCP1, IL10, IL8, IL6, TIMP1, PROTEIN_MMP9, CREATIVETPROTEIN	0.79	0.77	0.81
PROTEIN_MMP9, BETA2MICROGLOBULIN, APOLIPOPROTEINCIII, IL8, IL6, ALPHAFETOPROTEIN, CREATIVETPROTEIN	0.79	0.77	0.8
IL8, MCP1, CREATIVETPROTEIN, APOLIPOPROTEINCIII, ALPHAFETOPROTEIN, PROTEIN_MMP9, IL6	0.79	0.71	0.85
TIMP1, IL6, CREATIVETPROTEIN, APOLIPOPROTEINCIII, PROTEIN_MMP9, IL8, ALPHAFETOPROTEIN	0.78	0.76	0.8
IL10, IL6, BETA2MICROGLOBULIN, CREATIVETPROTEIN, APOLIPOPROTEINCIII, MCP1, IL8	0.78	0.7	0.85
APOLIPOPROTEINCIII, PROTEIN_MMP9, MCP1, IL6, ALPHAFETOPROTEIN, IL10, TIMP1	0.78	0.8	0.76
IL10, CREATIVETPROTEIN, ALPHAFETOPROTEIN, BETA2MICROGLOBULIN, IL8, PROTEIN_MMP9, APOLIPOPROTEINCIII	0.78	0.74	0.82
TIMP1, IL10, CREATIVETPROTEIN, APOLIPOPROTEINCIII, IL6, IL8, MCP1	0.78	0.81	0.74
IL8, TIMP1, CREATIVETPROTEIN, IL6, IL10, BETA2MICROGLOBULIN, APOLIPOPROTEINCIII	0.78	0.8	0.76
APOLIPOPROTEINCIII, CREATIVETPROTEIN, IL8, IL10, PROTEIN_MMP9, IL6, BETA2MICROGLOBULIN	0.78	0.78	0.77
TIMP1, MCP1, IL10, BETA2MICROGLOBULIN, PROTEIN_MMP9, IL6, ALPHAFETOPROTEIN, APOLIPOPROTEINCIII	0.8	0.74	0.86
TIMP1, PROTEIN_MMP9, IL6, ALPHAFETOPROTEIN, IL10, APOLIPOPROTEINCIII, MCP1, IL8	0.79	0.77	0.82
IL10, IL6, MCP1, CREATIVETPROTEIN, APOLIPOPROTEINCIII, PROTEIN_MMP9, BETA2MICROGLOBULIN, ALPHAFETOPROTEIN	0.79	0.79	0.79
TIMP1, MCP1, IL10, CREATIVETPROTEIN, ALPHAFETOPROTEIN, IL6, PROTEIN_MMP9, IL8	0.79	0.76	0.81
APOLIPOPROTEINCIII, ALPHAFETOPROTEIN, TIMP1, BETA2MICROGLOBULIN, MCP1, IL10, IL6, IL8	0.79	0.73	0.83
CREATIVETPROTEIN, TIMP1, APOLIPOPROTEINCIII, MCP1, IL6, ALPHAFETOPROTEIN, BETA2MICROGLOBULIN, PROTEIN_MMP9	0.78	0.78	0.79
BETA2MICROGLOBULIN, IL10, IL8, APOLIPOPROTEINCIII, PROTEIN_MMP9, IL6, TIMP1, CREATIVETPROTEIN	0.78	0.73	0.83
APOLIPOPROTEINCIII, IL8, ALPHAFETOPROTEIN, IL6, PROTEIN_MMP9, IL10, TIMP1, MCP1	0.78	0.78	0.77
APOLIPOPROTEINCIII, IL6, IL8, PROTEIN_MMP9, TIMP1, BETA2MICROGLOBULIN, IL10, CREATIVETPROTEIN	0.78	0.71	0.83

TABLE M-continued

Exemplary sets of biomarkers used in the methods or kits referenced in Sections 5.2 and 5.3			
BIOMARKER SET	ACCURACY	SPECIFICITY	SENSISTIVITY
APOLIPOPTEIN, MCP1, IL10, PROTEIN_MMP9, TIMP1, ALPHAFAFETOPROTEIN, CREACTIVEPROTEIN, IL6	0.77	0.76	0.78
PROTEIN_MMP9, CREACTIONPROTEIN, IL6, TIMP1, BETA2MICROGLOBULIN, IL10, APOLIPOPTEIN, MCP1, ALPHAFAFETOPROTEIN	0.79	0.78	0.81
APOLIPOPTEIN, PROTEIN_MMP9, ALPHAFAFETOPROTEIN, CREACTIVEPROTEIN, IL6, IL10, IL8, TIMP1, BETA2MICROGLOBULIN	0.79	0.77	0.81
ALPHAFAFETOPROTEIN, TIMP1, PROTEIN_MMP9, MCP1, IL6, APOLIPOPTEIN, BETA2MICROGLOBULIN, IL10, CREACTIVEPROTEIN	0.79	0.79	0.79
APOLIPOPTEIN, PROTEIN_MMP9, MCP1, BETA2MICROGLOBULIN, IL8, IL6, IL10, CREACTIVEPROTEIN, TIMP1	0.79	0.78	0.79
TIMP1, APOLIPOPTEIN, IL6, CREACTIVEPROTEIN, MCP1, PROTEIN_MMP9, IL8, BETA2MICROGLOBULIN, ALPHAFAFETOPROTEIN	0.79	0.72	0.84
BETA2MICROGLOBULIN, IL8, CREACTIVEPROTEIN, TIMP1, IL6, ALPHAFAFETOPROTEIN, APOLIPOPTEIN, PROTEIN_MMP9, IL10	0.78	0.77	0.79
IL6, IL8, TIMP1, PROTEIN_MMP9, IL10, BETA2MICROGLOBULIN, APOLIPOPTEIN, CREACTIVEPROTEIN, ALPHAFAFETOPROTEIN	0.78	0.73	0.83
PROTEIN_MMP9, IL10, MCP1, CREACTIVEPROTEIN, ALPHAFAFETOPROTEIN, IL6, TIMP1, APOLIPOPTEIN, BETA2MICROGLOBULIN	0.78	0.8	0.75
IL10, IL8, ALPHAFAFETOPROTEIN, IL6, TIMP1, PROTEIN_MMP9, MCP1, BETA2MICROGLOBULIN, CREACTIVEPROTEIN	0.78	0.79	0.76
ALPHAFAFETOPROTEIN, MCP1, IL6, BETA2MICROGLOBULIN, PROTEIN_MMP9, CREACTIONPROTEIN, TIMP1, APOLIPOPTEIN, IL10	0.78	0.78	0.78
TIMP1, IL6, CREACTIONPROTEIN, ALPHAFAFETOPROTEIN, IL10, BETA2MICROGLOBULIN, MCP1, APOLIPOPTEIN, IL8, PROTEIN_MMP9	0.79	0.78	0.81
IL8, CREACTIONPROTEIN, TIMP1, IL10, MCP1, IL6, ALPHAFAFETOPROTEIN, PROTEIN_MMP9, APOLIPOPTEIN, BETA2MICROGLOBULIN	0.79	0.78	0.8
MCP1, TIMP1, APOLIPOPTEIN, ALPHAFAFETOPROTEIN, PROTEIN_MMP9, IL10, CREACTIVEPROTEIN, BETA2MICROGLOBULIN, IL8, IL6	0.78	0.8	0.77
BETA2MICROGLOBULIN, MCP1, IL6, CREACTIVEPROTEIN, IL10, IL8, ALPHAFAFETOPROTEIN, APOLIPOPTEIN, TIMP1, PROTEIN_MMP9	0.78	0.78	0.79

TABLE M-continued

Exemplary sets of biomarkers used in the methods or kits referenced in Sections 5.2 and 5.3			
BIOMARKER SET	ACCURACY	SPECIFICITY	SENSISTIVITY
CREACTIVEPROTEIN, TIMP1, IL10, IL6, ALPHAFETOPROTEIN, APOLIPOPROTEINCIII, IL8, BETA2MICROGLOBULIN, MCP1, PROTEIN_MMP9	0.78	0.76	0.8
MCP1, TIMP1, IL6, ALPHAFETOPROTEIN, PROTEIN_MMP9, BETA2MICROGLOBULIN, APOLIPOPROTEINCIII, CREATIVETPROTEIN, IL8, IL10	0.78	0.78	0.78
ALPHAFETOPROTEIN, APOLIPOPROTEINCIII, PROTEIN_MMP9, BETA2MICROGLOBULIN, IL10, TIMP1, MCP1, IL6, IL8, CREATIVETPROTEIN	0.78	0.8	0.75
TIMP1, IL10, BETA2MICROGLOBULIN, IL8, APOLIPOPROTEINCIII, IL6, MCP1, CREATIVETPROTEIN, ALPHAFETOPROTEIN, PROTEIN_MMP9	0.78	0.76	0.8
BETA2MICROGLOBULIN, ALPHAFETOPROTEIN, MCP1, IL10, APOLIPOPROTEINCIII, TIMP1, CREATIVETPROTEIN, IL8, PROTEIN_MMP9, IL6	0.77	0.74	0.8
IL8, MCP1, BETA2MICROGLOBULIN, PROTEIN_MMP9, IL10, TIMP1, IL6, CREATIVETPROTEIN, ALPHAFETOPROTEIN, APOLIPOPROTEINCIII	0.77	0.79	0.75

[0438] In some embodiments, the methods or kits respectively described or referenced in Section 5.2 and Section 5.3 use any one of the subsets of biomarkers listed in Table N. The subsets of biomarkers listed in Table N were identified in the computational experiments described in Section 6.14.5, below, in which 4600 random subcombinations of the biomarkers listed in Table I were tested. Table N lists some of the biomarker sets that provided high accuracy scores against the validation population described in Section 6.14.5. Each row of Table N lists a single set of biomarkers that can be used in the methods and kits respectively referenced in Sections 5.2 and 5.3. In other words, each row of Table N describes a set of biomarkers that can be used to discriminate between sepsis and SIRS subjects. In some embodiments, nucleic acid forms of the biomarkers listed in Table N are used in the methods

and kits respectively referenced in Sections 5.2 and 5.3. In some embodiments, protein forms of the biomarkers listed in Table N are used. In some embodiments, some of the biomarkers in a biomarker set from Table N are in protein form and some of the biomarkers in the same biomarker set from Table N are in nucleic acid form in the methods and kits respectively referenced in Sections 5.2 and 5.3.

[0439] In some embodiments, a given set of biomarkers from Table N is used with the addition of one, two, three, four, five, six, seven, eight, or nine or more additional biomarkers from any one of Table 30, 31, 32, 33, 34, or 36 that are not within the given set of biomarkers from Table N. In Table N, accuracy, specificity, and sensitivity are described with reference to T_{-12} time point data described in Section 6.14.5, below.

TABLE N

Exemplary sets of biomarkers used in the methods or kits referenced in Sections 5.2 and 5.3			
BIOMARKER SET	ACCURACY	SPECIFICITY	SENSISTIVITY
TLR4, ARG2, OSM	0.85	0.83	0.88
IRAK4, OSM, TNFSF10	0.83	0.79	0.87
PSTPIP2, SOCS3, TIMP1	0.82	0.81	0.83
FCGR1A, IL6, MAP2K6	0.81	0.84	0.79
SOCS3, TNFSF10, NCR1	0.81	0.73	0.87
IL8, IL18R1, Beta2Microglobulin	0.81	0.79	0.82
OSM, NCR1, IL8	0.81	0.77	0.83
PFKFB3, MKNK1, FCGR1A	0.8	0.79	0.81
TIMP1, IL18R1, ARG2	0.8	0.78	0.83
FCGR1A, MAP2K6, IRAK4	0.8	0.75	0.86

TABLE N-continued

Exemplary sets of biomarkers used in the methods or kits referenced in Sections 5.2 and 5.3			
BIOMARKER SET	ACCURACY	SPECIFICITY	SENSITIVITY
Gene_MMP9, IL8, GADD45B	0.8	0.75	0.84
INSL3, ANKRD22, MAP2K6, LDLR	0.87	0.83	0.9
PSTPIP2, ARG2, CRTAP, GADD45A	0.83	0.81	0.85
CEACAM1, GADD45B, GADD45A, OSM	0.83	0.75	0.91
OSM, CSF1R, IL10, ANKRD22	0.83	0.88	0.78
TIMP1, ARG2, GADD45B, VNN1	0.83	0.83	0.82
HLA-DRA, PSTPIP2, INSL3, MKNK1	0.83	0.79	0.86
CD86, TGFBI, ANKRD22, SOCS3	0.82	0.82	0.83
GADD45A, PSTPIP2, GADD45B, IL18R1	0.82	0.76	0.86
ANKRD22, MAP2K6, Protein_MMP9, FAD104	0.81	0.8	0.82
IFNGR1, FAD104, CSF1R, IL8	0.81	0.78	0.84
OSM, TDRD9, ARG2, HLA-DRA	0.81	0.77	0.85
ANKRD22, CReactiveProtein, OSM, IL10	0.81	0.76	0.85
TDRD9, TNFSF13B, CReactiveProtein, MAP2K6	0.81	0.76	0.85
TNFSF10, Gene_MMP9, IL8, FCGR1A	0.8	0.79	0.81
IL10, NCR1, IL6, INSL3	0.8	0.79	0.81
CD86, FCGR1A, BCL2A1, LY96	0.8	0.79	0.81
IL8, VNN1, IL6, GADD45B	0.8	0.79	0.82
HLA-DRA, TNFSF10, OSM, MKNK1	0.8	0.76	0.84
PFKFB3, INSL3, IL10alpha, FCGR1A	0.8	0.76	0.84
TNFSF10, IRAK4, OSM, ARG2, MAPK14	0.85	0.84	0.86
CD86, CEACAM1, IL18R1, GADD45B, CCL5	0.83	0.85	0.81
MCP1, CSF1R, GADD45B, Protein_MMP9, Beta2Microglobulin	0.83	0.83	0.82
IL8, CD86, IRAK2, IL1RN, TIFA	0.82	0.84	0.81
IRAK4, OSM, INSL3, CEACAM1, TNFSF13B	0.82	0.82	0.82
CReactiveProtein, SOCS3, HLA-DRA, GADD45B, OSM	0.82	0.76	0.88
CD86, NCR1, PRV1, IL1RN, GADD45B	0.82	0.77	0.86
TNFRSF6, ITGAM, PSTPIP2, ARG2, BCL2A1	0.82	0.77	0.87
IRAK4, LDLR, OSM, PSTPIP2, GADD45A	0.81	0.81	0.82
Gene_MMP9, SOD2, PFKFB3, ARG2, CD86	0.81	0.78	0.84
CReactiveProtein, IL18R1, NCR1, CD86, GADD45A	0.81	0.78	0.84
IL8, IL18R1, LDLR, SOD2, PSTPIP2	0.81	0.77	0.84
Gene_MMP9, CSF1R, TGFBI, MAP2K6, ANKRD22	0.81	0.8	0.81
CReactiveProtein, LDLR, IRAK2, OSM, PSTPIP2	0.81	0.8	0.82
ITGAM, SOCS3, IL8, ARG2, JAK2	0.81	0.79	0.83
TNFSF10, LY96, IL10alpha, IL10, OSM	0.8	0.83	0.78
GADD45B, IL6, INSL3, ANKRD22, IL8	0.8	0.81	0.8
CSF1R, IL6, IL1RN, TLR4, JAK2	0.8	0.79	0.81
TDRD9, OSM, ITGAM, ANKRD22, Gene_MMP9	0.8	0.73	0.87
IL8, TNFRSF6, CReactiveProtein, IRAK4, PRV1	0.8	0.79	0.81
OSM, IL1RN, JAK2, GADD45B, CSF1R	0.8	0.78	0.82
CD86, Beta2Microglobulin, PFKFB3, TNFSF13B, TNFRSF6	0.8	0.78	0.82
MAPK14, TGFBI, GADD45A, ANKRD22, CReactiveProtein	0.8	0.75	0.85
MKNK1, CD86, OSM, TIFA, HLA-DRA, SOCS3	0.85	0.79	0.89
CD86, CEACAM1, LDLR, NCR1, AlphaFetoprotein, IRAK2	0.83	0.81	0.84
INSL3, PRV1, LY96, Protein_MMP9, IL8, OSM	0.82	0.82	0.82
FAD104, ARG2, FCGR1A, SOCS3, HLA- DRA, ANXA3	0.82	0.8	0.84
CCL5, TIMP1, ARG2, IL6, IFNGR1, SOD2	0.82	0.77	0.87
CRTAP, OSM, GADD45B, TNFSF10, MKNK1, TGFBI	0.82	0.75	0.88

TABLE N-continued

Exemplary sets of biomarkers used in the methods or kits referenced in Sections 5.2 and 5.3			
BIOMARKER SET	ACCURACY	SPECIFICITY	SENSISTIVITY
LDLR, OSM, IL6, JAK2, INSL3, FCGR1A	0.82	0.82	0.81
Beta2Microglobulin, FAD104, TGFB1, NCR1, ARG2, GADD45B	0.82	0.82	0.82
CSF1R, VNN1, MAP2K6, LY96, OSM, Beta2Microglobulin	0.82	0.81	0.82
ApolipoproteinCIII, HLA-DRA, GADD45A, ITGAM, TNFRSF6, MAP2K6	0.82	0.8	0.83
PRV1, TGFB1, VNN1, GADD45B, IL1RN, CSF1R	0.81	0.8	0.82
IRAK4, TIMP1, ANKRD22, GADD45B, OSM, TLR4	0.81	0.78	0.83
SOD2, MKNK1, MCP1, OSM, TIFA, SOCS3	0.81	0.77	0.84
FAD104, TGFB1, ANXA3, IL18R1, PRV1, IL10alpha	0.81	0.77	0.85
FCGR1A, IL8, Beta2Microglobulin, GADD45B, ANKRD22, TNFSF10	0.81	0.83	0.79
TIFA, Beta2Microglobulin, IL18R1, CRTAP, IL6, TGFB1	0.81	0.8	0.81
CD86, IL10, MCP1, TIMP1, OSM, ANXA3	0.81	0.79	0.82
INSL3, FAD104, TGFB1, CEACAM1, CSF1R, PFKFB3	0.81	0.77	0.85
PRV1, IL8, TNFSF10, FCGR1A, IFNGR1, CReactiveProtein	0.81	0.77	0.84
ANKRD22, BCL2A1, CRTAP, NCR1, SOCS3, IL18R1	0.81	0.72	0.88
INSL3, IRAK2, CD86, JAK2, IL10, FAD104	0.8	0.84	0.77
MCP1, PSTPIP2, AlphaFetoprotein, CReactiveProtein, IL6, ApolipoproteinCIII	0.8	0.81	0.8
CSF1R, OSM, IFNGR1, TDRD9, Gene__MMP9, FCGR1A	0.8	0.8	0.8
TIMP1, IFNGR1, TNFSF10, GADD45A, BCL2A1, SOD2	0.8	0.8	0.81
FCGR1A, MKNK1, CRTAP, LDLR, Gene__MMP9, Beta2Microglobulin	0.8	0.79	0.81
ITGAM, AlphaFetoprotein, FCGR1A, MCP1, MKNK1, GADD45A	0.8	0.78	0.82
MCP1, FCGR1A, OSM, PFKFB3, FAD104, TDRD9	0.8	0.77	0.82
TNFSF10, Gene__MMP9, FCGR1A, AlphaFetoprotein, INSL3, CSF1R, IL8	0.86	0.85	0.86
OSM, Beta2Microglobulin, ANKRD22, CSF1R, GADD45B, TNFRSF6,	0.84	0.85	0.83
ApolipoproteinCIII BCL2A1, TDRD9, OSM, PRV1, IRAK2, TLR4, MAPK14	0.84	0.83	0.85
LDLR, OSM, ApolipoproteinCIII, IL6, TIMP1, ARG2, TNFRSF6	0.83	0.83	0.83
IL1RN, TNFSF13B, AlphaFetoprotein, MCP1, ANKRD22, ARG2, OSM	0.83	0.8	0.85
NCR1, ARG2, PSTPIP2, GADD45A, LY96, OSM, BCL2A1	0.83	0.81	0.84
FCGR1A, TNFSF13B, INSL3, TIFA, ApolipoproteinCIII, ITGAM, CD86	0.83	0.79	0.87
LY96, CReactiveProtein, FCGR1A, Beta2Microglobulin, IL8, OSM, VNN1	0.82	0.85	0.8
PSTPIP2, ARG2, IRAK2, TNFSF13B, GADD45A, IL8, CRTAP	0.82	0.85	0.8
MCP1, SOCS3, HLA-DRA, ApolipoproteinCIII, IL10alpha, GADD45A, MAP2K6	0.82	0.84	0.81
IL18R1, MAPK14, Gene__MMP9, TIFA, FCGR1A, SOCS3, MKNK1	0.82	0.75	0.89
Beta2Microglobulin, CRTAP, ARG2, ANKRD22, TNFRSF6, IRAK4, OSM	0.82	0.82	0.82
PFKFB3, IRAK2, IRAK4, OSM, JAK2, Beta2Microglobulin, CEACAM1	0.82	0.82	0.82
TIFA, CRTAP, PFKFB3, JAK2, IL6, TGFB1, CD86	0.82	0.82	0.82

TABLE N-continued

Exemplary sets of biomarkers used in the methods or kits referenced in Sections 5.2 and 5.3			
BIOMARKER SET	ACCURACY	SPECIFICITY	SENSITIVITY
GADD45B, Gene_MMP9, TNFSF13B, IRAK2, VNN1, TIFA, SOCS3	0.82	0.76	0.88
INSL3, IL6, CD86, IL10alpha, CReactiveProtein, TGFBI, ITGAM	0.82	0.86	0.78
GADD45B, MCP1, INSL3, CReactiveProtein, ARG2, CCL5, SOCS3	0.82	0.81	0.82
TNFSF10, IL8, ApolipoproteinCIII, TGFBI, CSF1R, OSM, SOD2	0.82	0.8	0.83
PRV1, PSTPIP2, ARG2, TIMP1, Protein_MMP9, IL6, SOD2	0.82	0.79	0.84
CD86, LY96, MAP2K6, IL6, IL10, IRAK2, TNFSF10	0.81	0.78	0.84
BCL2A1, MCP1, ARG2, SOCS3, NCR1, IL10, LY96	0.81	0.8	0.81
SOCS3, ApolipoproteinCIII, NCR1, CEACAM1, ANKRD22, FCGR1A, IL6	0.81	0.8	0.82
INSL3, TNFSF10, SOD2, FCGR1A, PSTPIP2, IL10, IL8	0.81	0.77	0.85
FCGR1A, OSM, Protein_MMP9, GADD45A, PSTPIP2, ARG2, Gene_MMP9	0.81	0.76	0.84
TIMP1, SOCS3, LY96, CSF1R, CReactiveProtein, CCL5, TNFSF13B	0.81	0.84	0.77
ANKRD22, CEACAM1, TLR4, ApolipoproteinCIII, SOCS3, ITGAM, IL10	0.81	0.82	0.8
INSL3, IRAK2, FCGR1A, MAP2K6, CRTAP, ITGAM, CSF1R	0.81	0.81	0.8
VNN1, SOCS3, Beta2Microglobulin, MAP2K6, IL6, ANKRD22, IL10	0.81	0.81	0.81
TNFSF10, TGFBI, CReactiveProtein, Beta2Microglobulin, TNFRSF6, ARG2, PRV1	0.81	0.8	0.82
IL18R1, IL6, CRTAP, IRAK4, GADD45A, Protein_MMP9, TNFSF13B	0.8	0.81	0.79
AlphaFetoprotein, ARG2, NCR1, PSTPIP2, ApolipoproteinCIII, CD86, GADD45B	0.8	0.8	0.81
ANKRD22, TIFA, JAK2, IL10, IL6, CCL5, CSF1R	0.8	0.79	0.82
PRV1, TNFSF13B, TLR4, OSM, ARG2, AlphaFetoprotein, HLA-DRA	0.8	0.78	0.82
CSF1R, TLR4, SOD2, FCGR1A, CRTAP, TNFSF13B, GADD45A	0.8	0.78	0.83
JAK2, IRAK2, ITGAM, IL6, MKNK1, Gene_MMP9, FCGR1A	0.8	0.77	0.83
GADD45B, PRV1, CSF1R, NCR1, CD86, MKNK1, JAK2	0.8	0.76	0.83
Beta2Microglobulin, TNFSF10, IL18R1, GADD45B, Protein_MMP9, FAD104, PSTPIP2	0.8	0.75	0.85
MAPK14, TIFA, ITGAM, MKNK1, CSF1R, IRAK4, Protein_MMP9	0.8	0.73	0.86
TIFA, TNFSF13B, LY96, GADD45B, IL6, INSL3, OSM	0.8	0.8	0.8
IL6, GADD45B, CEACAM1, IRAK4, TGFBI, INSL3, TNFSF13B	0.8	0.8	0.8
GADD45B, ARG2, IL18R1, ANKRD22, AlphaFetoprotein, IL10, PSTPIP2	0.8	0.8	0.8
TNFSF13B, IFNGR1, OSM, FAD104, CSF1R, PSTPIP2, TIFA	0.8	0.8	0.8
TDRD9, ITGAM, TNFSF10, ANXA3, ApolipoproteinCIII, MCP1, INSL3	0.8	0.8	0.8
SOCS3, Protein_MMP9, SOD2, LY96, ARG2, IRAK2, OSM	0.8	0.78	0.82
CEACAM1, IL10, TNFRSF6, IL18R1, ARG2, FCGR1A, CReactiveProtein	0.8	0.78	0.82
CCL5, FCGR1A, CReactiveProtein, ApolipoproteinCIII, IL18R1, Protein_MMP9, ITGAM	0.8	0.74	0.86
NCR1, SOD2, IRAK2, IL8, OSM, HLA- DRA, ARG2, GADD45A	0.86	0.89	0.84
PFKFB3, PSTPIP2, GADD45B, INSL3, FAD104, TNFRSF6, ARG2, IL10alpha	0.85	0.86	0.84

TABLE N-continued

Exemplary sets of biomarkers used in the methods or kits referenced in Sections 5.2 and 5.3			
BIOMARKER SET	ACCURACY	SPECIFICITY	SENSITIVITY
CSF1R, CEACAM1, GADD45B, OSM, LDLR, MCP1, ARG2, AlphaFetoprotein	0.84	0.86	0.82
TIFA, NCR1, BCL2A1, OSM, CCL5, TLR4, CD86, CEACAM1	0.82	0.82	0.82
FAD104, LDLR, INSL3, IRAK4, LY96, TLR4, GADD45B, TIMP1	0.82	0.81	0.83
FAD104, JAK2, TNFSF13B, ARG2, CReactiveProtein, IL10alpha, TLR4, PRV1	0.82	0.79	0.85
CRTAP, LY96, TDRD9, Gene_MMP9, HLA-DRA, SOCS3, IL8, Protein_MMP9	0.82	0.79	0.85
CRTAP, GADD45B, TIFA, ApolipoproteinCIII, LY96, IL8, GADD45A, MKNK1	0.81	0.83	0.8
IL8, CSF1R, ARG2, TGFB1, PRV1, TNFRSF6, CEACAM1, JAK2	0.81	0.82	0.81
ARG2, Beta2Microglobulin, GADD45A, IL6, INSL3, IL8, JAK2, TIMP1	0.81	0.79	0.83
SOD2, IL10, IL8, ARG2, PSTPIP2, INSL3, CSF1R, ANXA3	0.81	0.77	0.86
CD86, IL6, BCL2A1, CCL5, GADD45B, IRAK4, LDLR, ARG2	0.81	0.86	0.76
ANXA3, MAP2K6, VNN1, GADD45A, CSF1R, FAD104, IL6, IRAK2	0.81	0.81	0.81
IL8, GADD45A, TDRD9, Beta2Microglobulin, ANKRD22, GADD45B, PRV1, CSF1R	0.81	0.8	0.82
IRAK4, PRV1, GADD45A, IL8, TNFSF13B, CD86, FCGR1A, TIMP1	0.81	0.79	0.82
IRAK4, MAPK14, GADD45B, HLA-DRA, JAK2, PRV1, SOD2, IL6	0.81	0.77	0.84
IL18R1, IL6, GADD45B, MAPK14, IL10, JAK2, IL8, ANKRD22	0.81	0.76	0.86
TLR4, IRAK2, TNFRSF6, TGFB1, IL8, ARG2, GADD45B, GADD45A	0.81	0.88	0.74
ANXA3, IFNGR1, SOCS3, VNN1, TIFA, CReactiveProtein, IRAK4, AlphaFetoprotein	0.81	0.8	0.81
ANKRD22, CCL5, TGFB1, CEACAM1, CD86, Gene_MMP9, IFNGR1, GADD45B	0.81	0.8	0.82
NCR1, ARG2, TIMP1, Beta2Microglobulin, ANXA3, TIFA, BCL2A1, MAP2K6	0.81	0.77	0.84
OSM, TIMP1, IL1RN, IL8, BCL2A1, IFNGR1, CSF1R, CD86	0.81	0.76	0.84
IL10, NCR1, IRAK2, IL18R1, ARG2, PSTPIP2, Gene_MMP9, LY96	0.81	0.76	0.84
IL18R1, TNFSF10, SOCS3, ApolipoproteinCIII, HLA-DRA, GADD45A, Beta2Microglobulin, ARG2	0.81	0.74	0.88
IL10alpha, IL10, MKNK1, LY96, OSM, JAK2, IFNGR1, CEACAM1	0.8	0.8	0.81
HLA-DRA, TIMP1, OSM, CD86, NCR1, IL1RN, TNFSF10, FAD104	0.8	0.78	0.82
CSF1R, TNFSF13B, ANKRD22, IFNGR1, Protein_MMP9, PFKFB3, NCR1, TGFB1	0.8	0.77	0.82
ANXA3, IL10alpha, PSTPIP2, CSF1R, IL1RN, FAD104, CD86, CReactiveProtein	0.8	0.77	0.83
CSF1R, ANKRD22, TGFB1, IRAK4, Protein_MMP9, TIMP1, HLA-DRA, PFKFB3	0.8	0.77	0.83
TNFSF13B, JAK2, ARG2, CCL5, IL18R1, GADD45B, CD86, GADD45A	0.8	0.76	0.85
GADD45B, BCL2A1, IL1RN, FCGR1A, MAPK14, SOCS3, ITGAM, PRV1	0.8	0.76	0.84
IL6, JAK2, CReactiveProtein, MCP1, TIMP1, BCL2A1, GADD45B, LY96	0.8	0.85	0.76
AlphaFetoprotein, ApolipoproteinCIII, CEACAM1, CRTAP, IL18R1, NCR1, TIMP1, TGFB1	0.8	0.84	0.77
ANXA3, FAD104, MKNK1, CReactiveProtein, AlphaFetoprotein, CSF1R, IRAK4, IL6	0.8	0.82	0.78

TABLE N-continued

Exemplary sets of biomarkers used in the methods or kits referenced in Sections 5.2 and 5.3			
BIOMARKER SET	ACCURACY	SPECIFICITY	SENSISTIVITY
TIMP1, VNN1, TIFA, CCL5, TDRD9, FCGR1A, ApolipoproteinCIII, IL1RN	0.8	0.82	0.78
TNFSF10, TLR4, JAK2, OSM, Beta2Microglobulin, ITGAM, IL1RN, HLA- DRA	0.8	0.8	0.81
ApolipoproteinCIII, MAPK14, IRAK2, TNFSF13B, GADD45B, SOCS3, CEACAM1, TNFSF10	0.8	0.79	0.81
IL1RN, ANKRD22, FCGR1A, GADD45A, TGFB1, CSF1R, MCP1, MAPK14	0.8	0.79	0.81
SOCS3, HLA-DRA, IRAK2, Protein_MMP9, MAP2K6, INSL3, CReactiveProtein, Gene_MMP9	0.8	0.79	0.81
INSL3, BCL2A1, ARG2, GADD45B, MAPK14, ITGAM, IRAK2, LDLR	0.8	0.78	0.82
GADD45B, Beta2Microglobulin, Protein_MMP9, IFNGR1, IRAK2, PSTPIP2, IL8, FCGR1A	0.8	0.77	0.82
CSF1R, HLA-DRA, IRAK4, FAD104, CRTAP, MCP1, GADD45B, CCL5, IL6	0.84	0.88	0.82
HLA-DRA, Gene_MMP9, FAD104, IRAK2, TNFRSF6, LY96, CReactiveProtein, FCGR1A, CD86	0.84	0.85	0.83
GADD45A, GADD45B, OSM, ARG2, FAD104, MAPK14, IRAK2, ITGAM, MKNK1	0.84	0.81	0.86
IL6, IL18R1, IL1RN, HLA-DRA, CD86, IRAK2, NCR1, TNFSF10, CCL5	0.83	0.88	0.8
CD86, IRAK2, ARG2, PFKFB3, MAPK14, PRV1, VNN1, HLA-DRA, FAD104	0.83	0.85	0.82
TDRD9, FCGR1A, ARG2, AlphaFetoprotein, JAK2, ApolipoproteinCIII, TIMP1, MAP2K6, CCL5	0.83	0.8	0.86
PFKFB3, CReactiveProtein, TDRD9, OSM, IFNGR1, CCL5, TIMP1, ARG2, ITGAM	0.83	0.85	0.81
NCR1, CSF1R, MAP2K6, INSL3, IFNGR1, FAD104, IL6, ARG2, IL18R1	0.83	0.85	0.81
PSTPIP2, OSM, LDLR, Protein_MMP9, LY96, TNFSF13B, ANXA3, IL1RN, Beta2Microglobulin	0.83	0.82	0.84
FAD104, NCR1, VNN1, IRAK2, ApolipoproteinCIII, IL10alpha, LDLR, FCGR1A, IRAK4	0.83	0.81	0.84
IL10alpha, HLA-DRA, TGFB1, FCGR1A, CSF1R, IRAK2, GADD45A, PFKFB3, SOCS3	0.82	0.84	0.81
IL8, IRAK4, CSF1R, IL18R1, AlphaFetoprotein, IL1RN, BCL2A1, TNFSF13B, INSL3	0.82	0.83	0.81
SOCS3, MAP2K6, PSTPIP2, OSM, MAPK14, MKNK1, ApolipoproteinCIII, IL18R1, TLR4	0.82	0.82	0.82
TIMP1, IL8, PFKFB3, CD86, SOCS3, JAK2, IRAK2, IL10alpha, Protein_MMP9	0.82	0.81	0.83
TIMP1, INSL3, TNFRSF6, PFKFB3, CD86, JAK2, IL8, CRTAP, Protein_MMP9	0.82	0.8	0.85
IRAK4, MAPK14, ApolipoproteinCIII, IL6, MAP2K6, MCP1, TIFA, ARG2, CD86	0.82	0.88	0.76
TLR4, IL10alpha, IL8, GADD45A, IRAK2, MAP2K6, MCP1, HLA-DRA, MAPK14	0.82	0.82	0.81
LY96, MCP1, CD86, VNN1, OSM, ARG2, TDRD9, CCL5, INSL3	0.81	0.83	0.8
CCL5, CRTAP, ApolipoproteinCIII, Gene_MMP9, IFNGR1, TNFSF13B, ANKRD22, GADD45A, OSM	0.81	0.81	0.81
MCP1, IL6, FCGR1A, PSTPIP2, VNN1, TNFSF10, TIMP1, Protein_MMP9, CReactiveProtein	0.81	0.79	0.83
PFKFB3, IL6, NCR1, MAP2K6, FAD104, CD86, TLR4, TDRD9, OSM	0.81	0.79	0.84

TABLE N-continued

Exemplary sets of biomarkers used in the methods or kits referenced in Sections 5.2 and 5.3			
BIOMARKER SET	ACCURACY	SPECIFICITY	SENSITIVITY
ApolipoproteinCIII, CReactiveProtein, TGFB1, MKNK1, PRV1, FAD104, HLA-DRA, ARG2, TIMP1	0.81	0.77	0.86
IL10alpha, IL10, ANXA3, IL6, CSF1R, TGFB1, PSTPIP2, IL8, INSL3	0.81	0.82	0.8
IL6, IRAK2, CReactiveProtein, CCL5, ANKRD22, MCP1, GADD45A, PFKFB3, IL10alpha	0.81	0.8	0.82
TIFA, IL1RN, IL6, ITGAM, CReactiveProtein, CCL5, TGFB1, IL10, NCR1	0.81	0.79	0.82
CEACAM1, IFNGR1, TNFSF10, INSL3, BCL2A1, Beta2Microglobulin, IL10, ARG2, SOCS3	0.81	0.78	0.84
SOCS3, LDLR, SOD2, FAD104, MAP2K6, PSTPIP2, GADD45B, IRAK4, GADD45A	0.81	0.75	0.86
MKNK1, IL8, TNFSF13B, FAD104, ITGAM, GADD45B, NCR1, IL18R1,	0.81	0.83	0.78
ApolipoproteinCIII IL8, Gene_MMP9, TNFSF10, MKNK1, MCP1, IL6, CCL5, ApolipoproteinCIII, SOD2	0.81	0.82	0.79
NCR1, PFKFB3, ApolipoproteinCIII, INSL3, OSM, VNN1, AlphaFetoprotein, TNFSF10, CRTAP	0.81	0.78	0.83
FCGR1A, CReactiveProtein, PRV1, NCR1, ARG2, INSL3, IL10, TGFB1, MAPK14	0.81	0.75	0.86
IL8, IRAK2, PFKFB3, CEACAM1, TIFA, Protein_MMP9, IRAK4, CRTAP, TDRD9	0.8	0.8	0.81
ARG2, INSL3, CSF1R, TNFSF13B, Beta2Microglobulin, PRV1, FCGR1A, GADD45B, CRTAP	0.8	0.79	0.82
GADD45A, IL8, TIMP1, CReactiveProtein, MAP2K6, TGFB1, CRTAP, TNFRSF6, BCL2A1	0.8	0.77	0.84
HLA-DRA, ApolipoproteinCIII, INSL3, FAD104, TIMP1, IRAK4, FCGR1A, IL6, GADD45A	0.8	0.77	0.84
ARG2, JAK2, IL1RN, VNN1, IRAK4, CSF1R, ANKRD22, BCL2A1, TDRD9	0.8	0.84	0.77
CReactiveProtein, PFKFB3, CD86, IL1RN, TLR4, Beta2Microglobulin, IRAK2, TNFSF10, TNFRSF6	0.8	0.8	0.8
GADD45B, MAP2K6, JAK2, MAPK14, TIMP1, IRAK4, CReactiveProtein, TLR4, TGFB1	0.8	0.79	0.81
JAK2, TLR4, CCL5, IL6, CReactiveProtein, IFNGR1, ApolipoproteinCIII, GADD45B, NCR1	0.8	0.73	0.87
CSF1R, TNFRSF6, INSL3, MKNK1, IL8, MAP2K6, FAD104, NCR1, IL1RN, MCP1	0.86	0.85	0.86
IL8, PRV1, SOCS3, IRAK2, ARG2, IL10alpha, NCR1, CCL5, CReactiveProtein, MKNK1	0.85	0.86	0.83
TNFSF13B, TLR4, ARG2, IL6, SOCS3, Beta2Microglobulin, FAD104, MCP1, HLA-DRA, PSTPIP2	0.84	0.8	0.88
IL6, MCP1, Beta2Microglobulin, IL1RN, TDRD9, IFNGR1, ApolipoproteinCIII, FCGR1A, OSM, IL8	0.84	0.82	0.86
FCGR1A, IL6, LY96, LDLR, IL18R1, CSF1R, CCL5, NCR1, TNFRSF6, IRAK4	0.84	0.81	0.87
IL6, TGFB1, IL18R1, ANXA3, IL1RN, GADD45B, ANKRD22, LDLR, TLR4, CEACAM1	0.83	0.84	0.82
MAPK14, IL6, CSF1R, IL1RN, ITGAM, Beta2Microglobulin, MAP2K6, IL10, PSTPIP2, FAD104	0.83	0.86	0.79
CReactiveProtein, FCGR1A, CCL5, ApolipoproteinCIII, OSM, IRAK2, GADD45A, CRTAP, PFKFB3, ITGAM	0.83	0.86	0.8

TABLE N-continued

Exemplary sets of biomarkers used in the methods or kits referenced in Sections 5.2 and 5.3			
BIOMARKER SET	ACCURACY	SPECIFICITY	SENSITIVITY
TNFSF10, AlphaFetoprotein, CCL5, IL8, IRAK4, OSM, IL10alpha, ARG2, CReactiveProtein, TIFA	0.82	0.79	0.85
TDRD9, TNFSF10, GADD45B, CReactiveProtein, IL8, ARG2, ANXA3, TGFB1, IL1RN, CCL5	0.82	0.85	0.78
IL10alpha, ANXA3, TNFSF10, IL1RN, TGFB1, FAD104, INSL3, MAP2K6, MAPK14, ApolipoproteinCIII	0.82	0.85	0.78
TIMP1, Beta2Microglobulin, ITGAM, LDLR, MCP1, IL8, FCGR1A, TIFA, IL10alpha, MAP2K6	0.82	0.82	0.81
TNFRSF6, TGFB1, JAK2, SOD2, ANXA3, VNN1, CCL5, INSL3, CSF1R, IL10	0.82	0.82	0.81
TDRD9, IL10alpha, MAPK14, NCR1, LY96, GADD45B, IRAK2, CReactiveProtein, INSL3, ITGAM	0.82	0.8	0.83
LDLR, JAK2, IFNGR1, IRAK2, SOCS3, ITGAM, Protein_MMP9, INSL3, ApolipoproteinCIII, CEACAM1	0.82	0.79	0.84
CSF1R, Beta2Microglobulin, IRAK4, MKNK1, PRV1, TNFRSF6, PSTPIP2, IL18R1, HLA-DRA, CCL5	0.82	0.78	0.85
BCL2A1, TLR4, IL8, TIMP1, SOD2, CReactiveProtein, CRTAP, ApolipoproteinCIII, GADD45B, FAD104	0.82	0.77	0.86
ARG2, OSM, TNFSF13B, CReactiveProtein, AlphaFetoprotein, IL6, CRTAP, Beta2Microglobulin, MCP1, TDRD9	0.81	0.86	0.77
FAD104, TNFSF13B, IL1RN, GADD45B, IFNGR1, IL18R1, TNFRSF6, MCP1, PRV1, IL8	0.81	0.82	0.8
IL8, ITGAM, CSF1R, TNFRSF6, INSL3, IL10alpha, IFNGR1, IL10, IL1RN, SOD2	0.81	0.82	0.81
MCP1, IFNGR1, TNFRSF6, MAPK14, FAD104, IL18R1, IRAK4, INSL3, IL10alpha, Beta2Microglobulin	0.81	0.78	0.84
NCR1, PRV1, Protein_MMP9, TIMP1, ANKRD22, INSL3, CD86, CCL5, MKNK1, Gene_MMP9	0.81	0.74	0.88
NCR1, INSL3, CEACAM1, FAD104, IL10alpha, TIFA, TNFSF13B, IL6, CCL5, CReactiveProtein	0.81	0.86	0.76
CRTAP, IL1RN, IL18R1, FAD104, NCR1, HLA-DRA, TGFB1, LY96, IL6, IRAK4	0.81	0.8	0.82
OSM, NCR1, IL8, GADD45B, Protein_MMP9, TNFRSF6, TNFSF13B, Beta2Microglobulin, IL1RN, IRAK2	0.81	0.8	0.82
CD86, IL10alpha, CSF1R, IRAK2, ANKRD22, OSM, AlphaFetoprotein, Gene_MMP9, IL10, IRAK4	0.81	0.79	0.83
ARG2, IRAK4, GADD45A, VNN1, IL18R1, JAK2, ANXA3, CSF1R, HLA-DRA, PFKFB3	0.81	0.79	0.83
LY96, TDRD9, NCR1, TNFRSF6, CSF1R, PRV1, IL18R1, ARG2, Beta2Microglobulin, IL10alpha	0.81	0.76	0.86
INSL3, TDRD9, CRTAP, TNFRSF6, IRAK4, SOD2, LDLR, ANKRD22, OSM, CSF1R	0.81	0.75	0.88
FAD104, PFKFB3, IL18R1, IL10, MAPK14, ARG2, CD86, IL1RN, CCL5, GADD45A	0.81	0.83	0.79
TNFSF10, CSF1R, TNFSF13B, MKNK1, ITGAM, PFKFB3, AlphaFetoprotein, SOCS3, TNFRSF6, FAD104	0.81	0.81	0.8
CSF1R, PFKFB3, ApolipoproteinCIII, TLR4, ARG2, PRV1, ANKRD22, ITGAM, TIFA, TNFRSF6	0.81	0.81	0.81
TGFB1, IL10, TDRD9, PFKFB3, INSL3, CSF1R, PSTPIP2, MKNK1, NCR1, HLA- DRA	0.81	0.8	0.81

TABLE N-continued

Exemplary sets of biomarkers used in the methods or kits referenced in Sections 5.2 and 5.3				
BIOMARKER SET	ACCURACY	SPECIFICITY	SENSISTIVITY	
ANKRD22, TIMP1, CRTAP, HLA-DRA, ApolipoproteinCIII, CD86, TNFRSF6, Gene_MMP9, VNN1, IL10	0.81	0.78	0.83	
ARG2, NCR1, IRAK4, FCGR1A, FAD104, TNFRSF6, PFKFB3, MAP2K6, TGFBI, MKNK1	0.81	0.77	0.84	
TLR4, ANKRD22, IL10alpha, VNN1, Protein_MMP9, TNFRSF6, ARG2, TNFSF10, OSM, FCGR1A	0.81	0.76	0.84	
FAD104, PRV1, Protein_MMP9, IL10alpha, ARG2, TNFSF13B, FCGR1A, CEACAM1, CCL5, IL1RN	0.81	0.75	0.86	
TNFRSF6, IL6, TGFBI, PSTPIP2, ANXA3, ANKRD22, ApolipoproteinCIII, OSM, SOCS3, MAPK14	0.8	0.83	0.78	
IL8, OSM, IRAK4, TDRD9, LDLR, TNFSF13B, IL10, IFNGR1, ARG2, SOD2	0.8	0.81	0.8	
PSTPIP2, BCL2A1, CD86, ANXA3, IL10alpha, SOD2, OSM, INSL3, TNFSF13B, GADD45B	0.8	0.84	0.77	
IL6, ANXA3, SOCS3, MAP2K6, TGFBI, ANKRD22, CRTAP, BCL2A1, CCL5, TLR4	0.8	0.83	0.77	
HLA-DRA, CSF1R, TGFBI, MAP2K6, BCL2A1, CD86, TLR4, IL1RN, IL6, ApolipoproteinCIII	0.8	0.82	0.78	
ApolipoproteinCIII, CCL5, SOCS3, TIMP1, Gene_MMP9, AlphaFetoprotein, ITGAM, INSL3, CEACAM1, LDLR	0.8	0.81	0.79	
IL8, TNFRSF6, IL6, IL1RN, PSTPIP2, ApolipoproteinCIII, CD86, JAK2, TLR4, Protein_MMP9	0.8	0.79	0.81	
IL10alpha, JAK2, MCP1, CEACAM1, ApolipoproteinCIII, BCL2A1, PRV1, Protein_MMP9, MAP2K6, IFNGR1	0.8	0.78	0.82	
FCGR1A, LY96, JAK2, GADD45B, LDLR, IL6, VNN1, MCP1, Gene_MMP9, SOD2	0.8	0.77	0.82	
CSF1R, TNFRSF6, INSL3, MKNK1, IL8, MAP2K6, FAD104, NCR1, IL1RN, MCP1	0.86	0.85	0.86	
IL8, PRV1, SOCS3, IRAK2, ARG2, IL10alpha, NCR1, CCL5, CReactiveProtein, MKNK1	0.85	0.86	0.83	
LDLR, CD86, NCR1, IRAK4, IL18R1, Protein_MMP9, PRV1, GADD45B, ARG2, LY96, AlphaFetoprotein	0.85	0.84	0.87	
MAP2K6, CD86, INSL3, ApolipoproteinCIII, IL8, OSM, TNFSF13B, IL1RN, BCL2A1, FAD104, GADD45A	0.85	0.81	0.88	
NCR1, GADD45B, TNFSF10, IL10alpha, FAD104, LY96, IL6, IL10, ARG2, CReactiveProtein, TGFBI	0.84	0.87	0.82	
CD86, CEACAM1, INSL3, PFKFB3, IL10alpha, FAD104, SOD2, Gene_MMP9, SOCS3, ApolipoproteinCIII, FCGR1A	0.83	0.86	0.81	
SOCS3, ARG2, ApolipoproteinCIII, IRAK4, PFKFB3, IFNGR1, NCR1, IL8, CReactiveProtein, VNN1, TDRD9	0.83	0.84	0.82	
ARG2, OSM, CReactiveProtein, SOD2, CEACAM1, FCGR1A, TIMP1, IL10, IL18R1, ANKRD22, IRAK2	0.83	0.85	0.81	
TGFBI, SOD2, IL10, CD86, CEACAM1, TDRD9, IRAK4, ANXA3, LDLR, OSM, ARG2	0.83	0.83	0.83	
CReactiveProtein, IL10alpha, TIMP1, LY96, IL8, SOD2, MAP2K6, MAPK14, TLR4, PSTPIP2, INSL3	0.83	0.83	0.83	
ARG2, PSTPIP2, SOD2, INSL3, FAD104, JAK2, TIFA, PFKFB3, IRAK2, IL6, ANXA3	0.83	0.8	0.86	
PSTPIP2, CEACAM1, GADD45A, ApolipoproteinCIII, ITGAM, PRV1, TLR4, IL10alpha, ARG2, SOCS3, NCR1	0.83	0.84	0.82	

TABLE N-continued

Exemplary sets of biomarkers used in the methods or kits referenced in Sections 5.2 and 5.3			
BIOMARKER SET	ACCURACY	SPECIFICITY	SENSISTIVITY
OSM, SOCS3, CSF1R, IRAK2, VNN1, IL6, SOD2, LDLR, BCL2A1, ANKRD22, CD86	0.83	0.82	0.83
CRTAP, LDLR, TGFBI, INSL3, TIFA, FAD104, AlphaFetoprotein, IL8, JAK2, IRAK4, BCL2A1	0.83	0.82	0.83
CD86, ITGAM, PSTPIP2, IL18R1, IL6, IFNGR1, GADD45B, IL10, Beta2Microglobulin, FCGR1A, FAD104	0.83	0.77	0.87
PRV1, Beta2Microglobulin, IL1RN, NCR1, CSF1R, IFNGR1, TIMP1, SOCS3, LDLR, TIFA, ARG2	0.82	0.84	0.81
IL10alpha, GADD45A, LDLR, SOCS3, MAP2K6, LY96, CSF1R, Protein_MMP9, MCP1, TDRD9, IL8	0.82	0.83	0.81
CSF1R, TDRD9, TIMP1, SOD2, FCGR1A, IFNGR1, INSL3, CD86, TNFRSF6, HLA- DRA, MAP2K6	0.82	0.83	0.82
IL8, IL18R1, BCL2A1, MKNK1, CReactiveProtein, CCL5, IL6, SOCS3, FCGR1A, PSTPIP2, ApolipoproteinCIII	0.82	0.82	0.83
ANXA3, IL6, CD86, SOD2, CEACAM1, FCGR1A, ANKRD22, NCR1, PSTPIP2, IL8, MAPK14	0.82	0.8	0.85
Protein_MMP9, TNFRSF6, ITGAM, CSF1R, INSL3, TIFA, BCL2A1, IL1RN, TGFBI, FCGR1A, ApolipoproteinCIII	0.82	0.79	0.85
ANKRD22, IL10alpha, SOCS3, IRAK4, OSM, INSL3, TGFBI, MCP1, IL8, TNFSF13B, PRV1	0.82	0.76	0.88
ANKRD22, LDLR, VNN1, TIMP1, IRAK2, IL10alpha, GADD45B, ARG2, MAPK14, CSF1R, TNFRSF6	0.82	0.85	0.8
TIFA, ARG2, TNFSF10, INSL3, CD86, IL8, IRAK2, OSM, CSF1R, HLA-DRA, ITGAM	0.82	0.82	0.82
ANKRD22, TIFA, PSTPIP2, CCL5, Gene_MMP9, Beta2Microglobulin, NCR1, FCGR1A, INSL3, SOCS3, IL10alpha	0.82	0.79	0.84
ApolipoproteinCIII, AlphaFetoprotein, NCR1, CCL5, GADD45A, IL18R1, JAK2, TDRD9, OSM, TLR4, Gene_MMP9	0.82	0.82	0.81
CReactiveProtein, IL18R1, TGFBI, TNFSF10, MAP2K6, LDLR, FAD104, ARG2, HLA-DRA, GADD45B, ANXA3	0.82	0.8	0.83
IL18R1, IRAK4, LY96, INSL3, TNFRSF6, CReactiveProtein, CD86, GADD45B, CRTAP, IL8, MAPK14	0.82	0.8	0.83
IL8, FCGR1A, CSF1R, VNN1, IL10alpha, PSTPIP2, IL6, IL1RN, TLR4, GADD45B, LY96	0.81	0.85	0.78
HLA-DRA, IL6, FAD104, GADD45A, INSL3, ITGAM, CSF1R, IFNGR1, Protein_MMP9, SOCS3, NCR1	0.81	0.79	0.84
IL10, LDLR, AlphaFetoprotein, IL1RN, INSL3, ApolipoproteinCIII, PSTPIP2, CCL5, SOD2, TGFBI, VNN1	0.81	0.79	0.84
Protein_MMP9, IL10, TGFBI, INSL3, IRAK2, TNFRSF6, IL8, PSTPIP2, OSM, AlphaFetoprotein, NCR1	0.81	0.84	0.78
IL8, TLR4, MCP1, ApolipoproteinCIII, Beta2Microglobulin, IL6, IL10, VNN1, CD86, PSTPIP2, ITGAM	0.81	0.83	0.79
FAD104, GADD45A, SOCS3, PSTPIP2, IL6, TGFBI, TIMP1, HLA-DRA, TNFSF10, IL10alpha, MKNK1	0.81	0.81	0.81
PRV1, IL8, FCGR1A, GADD45A, IRAK2, VNN1, CD86, IL18R1, Protein_MMP9, MAP2K6, ITGAM	0.81	0.81	0.81
CRTAP, JAK2, IRAK2, CEACAM1, PRV1, CCL5, SOD2, BCL2A1, SOCS3, IL1RN, ApolipoproteinCIII	0.81	0.79	0.82

TABLE N-continued

Exemplary sets of biomarkers used in the methods or kits referenced in Sections 5.2 and 5.3			
BIOMARKER SET	ACCURACY	SPECIFICITY	SENSISTIVITY
MCP1, CCL5, HLA-DRA, IRAK4, OSM, LDLR, PFKFB3, CReactiveProtein, MKNK1, GADD45A, LY96	0.81	0.76	0.85
ARG2, INSL3, IL6, ITGAM, TGFBI, LDLR, IL10, CD86, IL8, TNFSF13B, IL10alpha Protein_MMP9, CD86, GADD45B, LY96,	0.81	0.82	0.79
SOD2, FCGR1A, IL8, AlphaFetoprotein, CSF1R, FAD104, CRTAP TNFSF13B, ApolipoproteinCIII, LDLR, TDRD9, CEACAM1, AlphaFetoprotein, IRAK4, INSL3, GADD45A, CRTAP, IFNGR1	0.81	0.77	0.84
MKNK1, PSTPIP2, Beta2Microglobulin, ANKRD22, TIFA, IL10alpha, TGFBI, AlphaFetoprotein, NCR1, PRV1, SOCS3	0.8	0.82	0.79
TIFA, MKNK1, IL6, ANXA3, FAD104, PSTPIP2, TNFSF13B, LDLR, INSL3, SOD2, JAK2	0.8	0.82	0.79
TNFSF13B, IFNGR1, IL18R1, CD86, Beta2Microglobulin, TGFBI, CSF1R, CReactiveProtein, CRTAP, MCP1, JAK2	0.8	0.81	0.8
TNFSF13B, Beta2Microglobulin, CSF1R, JAK2, CRTAP, IL1RN, IL10, SOCS3, ANKRD22, PFKFB3, LDLR	0.8	0.79	0.82
TNFRSF6, OSM, PRV1, INSL3, TLR4, MKNK1, IRAK4, HLA-DRA, VNN1, IL10alpha, FCGR1A	0.8	0.77	0.83
IL8, ApolipoproteinCIII, GADD45B, SOCS3, ARG2, TNFSF13B, IL1RN, CCL5, ANXA3, CReactiveProtein, TIFA	0.8	0.77	0.83
TNFSF13B, SOCS3, Protein_MMP9, SOD2, TNFRSF6, NCR1, FAD104, IL6, OSM, CCL5, TDRD9	0.8	0.76	0.86
CD86, INSL3, ANXA3, GADD45B, VNN1, IFNGR1, IL6, PFKFB3, PSTPIP2, Beta2Microglobulin, IRAK2	0.8	0.84	0.77
IL6, Gene_MMP9, FAD104, TIFA, TGFBI, Beta2Microglobulin, IL10alpha, ANXA3, IL18R1, NCR1, INSL3	0.8	0.82	0.78
CEACAM1, JAK2, MCP1, OSM, IL18R1, MKNK1, ANKRD22, TLR4, CSF1R, PSTPIP2, IL1RN	0.8	0.82	0.78
CSF1R, AlphaFetoprotein, HLA-DRA, TDRD9, ITGAM, SOCS3, FCGR1A, IRAK2, TIFA, TNFSF10, Protein_MMP9	0.8	0.8	0.8
CSF1R, IL10alpha, TNFRSF6, TNFSF13B, LDLR, INSL3, AlphaFetoprotein, IL10, TIFA, VNN1, HLA-DRA	0.8	0.79	0.81
IL18R1, MCP1, ANKRD22, TGFBI, ARG2, ANXA3, GADD45A, IL1RN, TNFRSF6, PSTPIP2, IRAK2	0.8	0.77	0.83
IL10alpha, IFNGR1, MAPK14, FCGR1A, Gene_MMP9, GADD45A, VNN1, ANKRD22, TNFSF13B, CCL5, IRAK2	0.8	0.76	0.83
IL8, CReactiveProtein, CSF1R, TLR4, TNFRSF6, Gene_MMP9, TDRD9, OSM, PFKFB3, IFNGR1, ApolipoproteinCIII, PSTPIP2	0.85	0.85	0.85
JAK2, OSM, GADD45B, MCP1, IL1RN, ANKRD22, IL18R1, Gene_MMP9, ITGAM, NCR1, ApolipoproteinCIII, PFKFB3	0.85	0.81	0.88
TNFSF10, MKNK1, PFKFB3, ANXA3, CRTAP, CD86, MAPK14, IL8, OSM, GADD45B, HLA-DRA, INSL3	0.84	0.84	0.84
IL1RN, AlphaFetoprotein, ARG2, MAP2K6, CEACAM1, GADD45B, CRTAP, ANXA3, INSL3, ApolipoproteinCIII, NCR1, FAD104	0.83	0.86	0.82
IL6, LDLR, TDRD9, TNFRSF6, NCR1, ITGAM, AlphaFetoprotein, FCGR1A, ARG2, TNFSF10, OSM, BCL2A1	0.83	0.84	0.83

TABLE N-continued

Exemplary sets of biomarkers used in the methods or kits referenced in Sections 5.2 and 5.3				
BIOMARKER SET	ACCURACY	SPECIFICITY	SENSISTIVITY	
IL10, SOD2, GADD45A, TNFSF13B, IRAK4, LY96, HLA-DRA, PSTPIP2, IL6, IFNGR1, ARG2, LDLR	0.83	0.86	0.81	
CCL5, CSF1R, LDLR, GADD45A, INSL3, JAK2, AlphaFetoprotein, OSM, Beta2Microglobulin, PRV1, HLA-DRA, MKNK1	0.83	0.8	0.86	
ANKRD22, TNFSF13B, TIMP1, VNN1, IRAK4, FCGR1A, CEACAM1, IRAK2, ARG2, ANXA3, CD86, IL1RN	0.83	0.83	0.83	
JAK2, AlphaFetoprotein, IL1RN, SOCS3, ANKRD22, IL10alpha, IL8, TGFBI, CD86, IL10, CSF1R, CReactiveProtein	0.82	0.83	0.82	
VNN1, GADD45B, MAP2K6, TNFSF13B, IRAK2, TLR4, CReactiveProtein, PSTPIP2, MCP1, CSF1R, IL8, TDRD9	0.82	0.79	0.85	
SOD2, IL10, CReactiveProtein, ApolipoproteinCIII, Beta2Microglobulin, IFNGR1, OSM, TNFSF13B, VNN1, GADD45B, CD86, PFKFB3	0.82	0.77	0.86	
LDLR, CRTAP, PSTPIP2, GADD45B, IL8, TNFRSF6, MAP2K6, IL10, ARG2, LY96, MAPK14, IL18R1	0.82	0.82	0.82	
IFNGR1, NCR1, ApolipoproteinCIII, ANXA3, CSF1R, CCL5, FCGR1A, TIFA, TLR4, INSL3, IL8, ARG2	0.82	0.82	0.82	
LY96, Beta2Microglobulin, CCL5, LDLR, IRAK4, TIMP1, MKNK1, ApolipoproteinCIII, IL8, SOCS3, ANKRD22, PRV1	0.82	0.78	0.86	
Protein_MMP9, MAPK14, IL1RN, SOCS3, MKNK1, ApolipoproteinCIII, IL10, OSM, MAP2K6, TNFSF13B, NCR1, IL18R1	0.82	0.77	0.87	
TNFSF13B, FAD104, OSM, TNFRSF6, TDRD9, TIFA, IL10alpha, INSL3, Protein_MMP9, HLA-DRA, Beta2Microglobulin, ApolipoproteinCIII	0.82	0.81	0.83	
TLR4, Protein_MMP9, VNN1, IFNGR1, ITGAM, MCP1, LY96, IRAK2, OSM, TDRD9, IL8, ApolipoproteinCIII	0.82	0.78	0.85	
MAP2K6, OSM, GADD45B, IL1RN, MAPK14, ARG2, LY96, VNN1, TNFRSF6, TGFBI, CD86, Beta2Microglobulin	0.81	0.81	0.81	
MKNK1, ARG2, CEACAM1, GADD45A, AlphaFetoprotein, GADD45B, HLA-DRA, CReactiveProtein, SOD2, TLR4, LDLR, TNFRSF6	0.81	0.81	0.81	
Protein_MMP9, TGFBI, PRV1, Beta2Microglobulin, TNFSF13B, TLR4, INSL3, Gene_MMP9, ARG2, ApolipoproteinCIII, MKNK1, IL10alpha	0.81	0.81	0.82	
TLR4, TGFBI, FCGR1A, NCR1, LY96, IL10, CCL5, IRAK2, INSL3, TDRD9, OSM, BCL2A1	0.81	0.81	0.82	
Gene_MMP9, FCGR1A, PSTPIP2, TIFA, CSF1R, SOD2, ITGAM, PFKFB3, JAK2, IL8, LY96, OSM	0.81	0.81	0.82	
CRTAP, MKNK1, TDRD9, LY96, TLR4, TNFSF10, SOD2, JAK2, Beta2Microglobulin, CD86, PSTPIP2, MAP2K6	0.81	0.8	0.83	
TGFBI, TDRD9, ARG2, OSM, TNFSF13B, CEACAM1, CCL5, CReactiveProtein, TLR4, IL10alpha, LY96, SOCS3	0.81	0.78	0.85	
IRAK2, LDLR, ARG2, SOD2, IL10alpha, ANKRD22, FCGR1A, Beta2Microglobulin, FAD104, ITGAM, PRV1, OSM	0.81	0.78	0.84	
FAD104, IL10alpha, INSL3, IL18R1, IL1RN, MKNK1, MAP2K6, Gene_MMP9, IRAK2, PSTPIP2, CEACAM1, IL6	0.81	0.83	0.79	

TABLE N-continued

Exemplary sets of biomarkers used in the methods or kits referenced in Sections 5.2 and 5.3			
BIOMARKER SET	ACCURACY	SPECIFICITY	SENSISTIVITY
VNN1, ApolipoproteinCIII, IL10, JAK2, Protein_MMP9, INSL3, Beta2Microglobulin, OSM, IRAK4, MAP2K6, IL1RN, AlphaFetoprotein	0.81	0.82	0.8
BCL2A1, GADD45A, JAK2, FCGR1A, FAD104, Gene_MMP9, CRTAP, TDRD9, MAP2K6, CSF1R, PRV1, Protein_MMP9	0.81	0.81	0.81
INSL3, TIFA, LY96, FAD104, PSTPIP2, PFKFB3, Beta2Microglobulin, TIMP1, IL18R1, GADD45A, IL6, AlphaFetoprotein	0.81	0.8	0.82
TDRD9, PFKFB3, CSF1R, ITGAM, MCP1, ARG2, TNFSF13B, PSTPIP2, MAP2K6, ANXA3, OSM, TGFBI	0.81	0.79	0.83
TNFSF10, TNFRSF6, Beta2Microglobulin, PRV1, SOCS3, IL8, VNN1, TDRD9, CReactiveProtein, GADD45B, TNFSF13B, CD86	0.81	0.77	0.84
MAP2K6, IFNGR1, LY96, Beta2Microglobulin, GADD45B, ANKRD22, SOCS3, ANXA3, INSL3, Protein_MMP9, CD86, HLA-DRA	0.81	0.76	0.85
SOD2, TIMP1, ApolipoproteinCIII, Protein_MMP9, FAD104, ANXA3, TLR4, CCL5, ITGAM, IRAK4, SOCS3, HLA-DRA	0.81	0.76	0.85
ITGAM, INSL3, FCGR1A, ARG2, IRAK2, FAD104, IRAK4, MAPK14, LY96, TIMP1, PRV1, TLR4, CD86	0.85	0.82	0.88
PRV1, MKNK1, IL8, FAD104, VNN1, SOCS3, ARG2, MAP2K6, IL1RN, SOD2, IL18R1, NCR1, BCL2A1	0.85	0.84	0.86
NCR1, CEACAM1, IRAK4, ARG2, TNFSF13B, PFKFB3, OSM, TNFRSF6, SOCS3, HLA-DRA, TNFSF10, JAK2, SOD2	0.85	0.79	0.89
MCP1, Protein_MMP9, IL10alpha, FAD104, FCGR1A, ITGAM, TGFBI, ApolipoproteinCIII, ARG2, PRV1, CRTAP, TIFA, LDLR	0.84	0.81	0.87
ARG2, ANKRD22, GADD45B, IRAK2, OSM, MKNK1, ANXA3, IL18R1, TNFRSF6, MAP2K6, AlphaFetoprotein, MCP1, ApolipoproteinCIII	0.84	0.83	0.85
HLA-DRA, NCR1, CEACAM1, Beta2Microglobulin, VNN1, AlphaFetoprotein, MCP1, IL6, FCGR1A, OSM, CSF1R, IRAK2, CRTAP	0.83	0.82	0.85
CReactiveProtein, SOD2, GADD45A, ARG2, IRAK4, FCGR1A, IL18R1, TLR4, JAK2, BCL2A1, IL10alpha, TGFBI, AlphaFetoprotein	0.83	0.86	0.81
ApolipoproteinCIII, HLA-DRA, TNFSF10, TLR4, IL10, GADD45B, BCL2A1, IL6, CCL5, INSL3, MAP2K6, LDLR, IFNGR1	0.83	0.83	0.83
TIFA, JAK2, HLA-DRA, SOCS3, ARG2, OSM, AlphaFetoprotein, MAPK14, IRAK2, IFNGR1, FCGR1A, MAP2K6, PRV1	0.83	0.79	0.87
Beta2Microglobulin, IRAK2, MKNK1, ANKRD22, CD86, OSM, CSF1R, TNFSF10, IFNGR1, TLR4, MCP1, FAD104, TGFBI	0.83	0.83	0.83
VNN1, FCGR1A, ANKRD22, CRTAP, ANXA3, IL8, PFKFB3, NCR1, TLR4, AlphaFetoprotein, TIFA, IRAK4, CD86	0.83	0.82	0.84
Gene_MMP9, INSL3, FCGR1A, LDLR, OSM, PFKFB3, ANKRD22, IL1RN, IL8, IFNGR1, TDRD9, BCL2A1, TNFSF13B	0.83	0.81	0.84
PFKFB3, AlphaFetoprotein, IRAK4, NCR1, TNFSF10, TDRD9, JAK2, FAD104, IL10alpha, PRV1, CReactiveProtein, TGFBI, Protein_MMP9	0.82	0.81	0.84
Gene_MMP9, MAP2K6, MAPK14, CReactiveProtein, PFKFB3, CCL5, CSF1R,	0.82	0.76	0.88

TABLE N-continued

Exemplary sets of biomarkers used in the methods or kits referenced in Sections 5.2 and 5.3			
BIOMARKER SET	ACCURACY	SPECIFICITY	SENSISTIVITY
INSL3, MKNK1, ARG2, FAD104, SOD2, Protein_MMP9			
IL8, TNFSF13B, ARG2, TIFA, CRTAP, OSM, IL18R1, MCP1, IRAK4, LY96, AlphaFetoprotein, TDRD9, CReactiveProtein	0.82	0.85	0.79
PSTPIP2, CEACAM1, GADD45B, MAPK14, ARG2, FCGR1A, ITGAM, TGFB1, IL10alpha, OSM, PRV1, IL8, TLR4	0.82	0.83	0.81
OSM, CReactiveProtein, CD86, LY96, IL10alpha, FAD104, TDRD9, IL6, ApolipoproteinCIII, LDLR, CSF1R, IL18R1, MCP1	0.82	0.82	0.82
JAK2, IL8, ARG2, OSM, BCL2A1, TIFA, IL6, Gene_MMP9, PRV1, TLR4, IL1RN, LY96, IRAK2	0.82	0.83	0.8
IL6, INSL3, BCL2A1, TLR4, HLA-DRA, IL10alpha, MKNK1, TDRD9, GADD45A, OSM, SOCS3, CCL5, MAPK14	0.82	0.81	0.82
LDLR, FCGR1A, SOD2, LY96, MKNK1, PRV1, MAP2K6, NCR1, Protein_MMP9, SOCS3, AlphaFetoprotein, IFNGR1, INSL3	0.82	0.77	0.86
TNFRSF6, ARG2, INSL3, ANXA3, IL10, TIFA, ITGAM, VNN1, SOD2, TIMP1, CSF1R, Protein_MMP9, SOCS3	0.82	0.77	0.87
IL10alpha, TNFRSF6, ARG2, TIMP1, IL8, CSF1R, MAP2K6, IRAK4, PFKFB3, FCGR1A, AlphaFetoprotein, OSM, HLA- DRA	0.81	0.85	0.78
Protein_MMP9, CD86, IFNGR1, TIMP1, IL1RN, FCGR1A, ARG2, TIFA, IL8, CRTAP, CSF1R, IL6, ITGAM	0.81	0.81	0.81
CEACAM1, ANKRD22, CCL5, TLR4, IRAK4, Beta2Microglobulin, MAP2K6, PRV1, TGFB1, FAD104, SOD2, JAK2, MCP1	0.81	0.81	0.82
CD86, VNN1, PSTPIP2, PFKFB3, CReactiveProtein, IL6, TLR4, CCL5, FCGR1A, TDRD9, TNFRSF6, CSF1R, CRTAP	0.81	0.86	0.77
LDLR, OSM, MCP1, CD86, IL1RN, Protein_MMP9, MAP2K6, FCGR1A, IL8, CEACAM1, PFKFB3, IRAK4, LY96	0.81	0.83	0.78
CReactiveProtein, TNFSF13B, ApolipoproteinCIII, IRAK2, VNN1, FCGR1A, PFKFB3, HLA-DRA, ANKRD22, SOD2, CD86, TGFB1, Beta2Microglobulin	0.81	0.79	0.82
LY96, TNFSF10, PRV1, PSTPIP2, SOCS3, TIMP1, IFNGR1, ARG2, CEACAM1, CCL5, TNFSF13B, LDLR, ApolipoproteinCIII	0.81	0.79	0.83
PRV1, JAK2, FCGR1A, VNN1, SOCS3, TIFA, CRTAP, INSL3, IFNGR1, TDRD9, CEACAM1, Protein_MMP9, IL8	0.81	0.79	0.83
GADD45A, SOCS3, OSM, CD86, ITGAM, ApolipoproteinCIII, FAD104, INSL3, PSTPIP2, IL18R1, AlphaFetoprotein, TDRD9, MAP2K6	0.81	0.77	0.84
PSTPIP2, VNN1, IL1RN, CSF1R, CD86, TLR4, IRAK4, IFNGR1, CRTAP, TNFSF10, SOD2, TIFA, TDRD9	0.81	0.77	0.85
TNFRSF6, IFNGR1, TNFSF13B, MAP2K6, MKNK1, ANXA3, TGFB1, OSM, ARG2, Beta2Microglobulin, CReactiveProtein, LY96, ApolipoproteinCIII, TIFA	0.85	0.88	0.83
CSF1R, TLR4, IL6, TNFSF13B, Beta2Microglobulin, IRAK4, FCGR1A, CCL5, ITGAM, VNN1, TIFA, CRTAP, PFKFB3, TDRD9	0.84	0.85	0.83
CReactiveProtein, IL6, MAP2K6, OSM, ARG2, ANKRD22, JAK2, HLA-DRA,	0.84	0.82	0.85

TABLE N-continued

Exemplary sets of biomarkers used in the methods or kits referenced in Sections 5.2 and 5.3			
BIOMARKER SET	ACCURACY	SPECIFICITY	SENSITIVITY
ApolipoproteinCIII, MAPK14, TLR4, TNFSF13B, IFNGR1, IL10alpha, VNN1, GADD45B, IRAK2, TGFBI, NCR1, IL6, CEACAM1, CRTAP, Gene_MMP9, TNFRSF6, CD86, TDRD9, CReactiveProtein, IL10	0.84	0.77	0.89
CRTAP, IL18R1, Beta2Microglobulin, ANXA3, TDRD9, MKNK1, Protein_MMP9, IL6, TNFSF10, OSM, MCP1, PFKFB3, ApolipoproteinCIII, VNN1	0.83	0.81	0.85
PSTPIP2, IL8, IL18R1, CEACAM1, HLA-DRA, OSM, NCR1, MCP1, FCGR1A, TNFRSF6, TLR4, IRAK2, Protein_MMP9, CReactiveProtein	0.83	0.79	0.86
PRV1, IRAK4, FAD104, TGFBI, Protein_MMP9, INSL3, AlphaFetoprotein, CD86, VNN1, CSF1R, Beta2Microglobulin, GADD45B, BCL2A1, IL10	0.83	0.83	0.82
CD86, MAP2K6, PSTPIP2, TNFSF10, OSM, GADD45B, TLR4, HLA-DRA, LY96, TNFSF13B, ARG2, SOD2, PRV1, Beta2Microglobulin	0.83	0.81	0.84
TIFA, CSF1R, IL10alpha, IFNGR1, CEACAM1, CRTAP, ANKRD22, FCGR1A, MAP2K6, FAD104, PSTPIP2, MAPK14, ARG2, IRAK2	0.83	0.77	0.87
CReactiveProtein, TDRD9, IL8, ITGAM, IL10alpha, TNFRSF6, SOD2, MCP1, SOCS3, MKNK1, FAD104, MAP2K6, IFNGR1, AlphaFetoprotein	0.82	0.86	0.78
TLR4, ANKRD22, IL10alpha, CReactiveProtein, ApolipoproteinCIII, BCL2A1, FCGR1A, SOD2, OSM, IFNGR1, TGFBI, TIFA, VNN1, CEACAM1	0.82	0.86	0.78
FCGR1A, IRAK4, MAP2K6, ANXA3, MAPK14, INSL3, AlphaFetoprotein, IL8, MKNK1, ARG2, VNN1, TIMP1, CSF1R, GADD45A	0.82	0.86	0.79
ANKRD22, HLA-DRA, IFNGR1, GADD45A, TNFSF13B, FAD104, LDLR, IL10alpha, IL6, MAPK14, ApolipoproteinCIII, PRV1, CReactiveProtein, TIMP1	0.82	0.81	0.84
IL10, PSTPIP2, INSL3, LY96, NCR1, MAPK14, VNN1, MCP1, PRV1, ApolipoproteinCIII, TIMP1, Protein_MMP9, TDRD9, PFKFB3	0.82	0.76	0.87
TNFRSF6, TGFBI, LY96, TDRD9, CRTAP, AlphaFetoprotein, TNFSF10, CCL5, JAK2, IL6, IRAK2, HLA-DRA, OSM, ApolipoproteinCIII	0.82	0.85	0.79
TIFA, Gene_MMP9, IL18R1, TDRD9, SOCS3, TIMP1, IL6, CCL5, ARG2, CSF1R, OSM, IL10alpha, IL8, TNFSF13B	0.82	0.84	0.8
PSTPIP2, PRV1, MAPK14, OSM, CRTAP, IFNGR1, IL6, FAD104, IL18R1, JAK2, GADD45B, LY96, BCL2A1, TLR4	0.82	0.82	0.82
GADD45A, IL6, TGFBI, BCL2A1, CRTAP, CCL5, TIFA, TLR4, CD86, PRV1, FAD104, TDRD9, TNFSF10, SOCS3	0.82	0.8	0.84
Beta2Microglobulin, JAK2, TDRD9, PSTPIP2, HLA-DRA, IL1RN, TGFBI, INSL3, ARG2, LDLR, AlphaFetoprotein, IRAK2, SOD2, MAPK14	0.82	0.79	0.85
CD86, FAD104, AlphaFetoprotein, Gene_MMP9, MCP1, HLA-DRA, INSL3, PSTPIP2, IL1RN, ITGAM, TIMP1, Protein_MMP9, IL6, IRAK4	0.82	0.77	0.86
ANKRD22, MAPK14, GADD45A, TDRD9, IL10alpha, Protein_MMP9, ARG2, CD86,	0.82	0.88	0.75

TABLE N-continued

Exemplary sets of biomarkers used in the methods or kits referenced in Sections 5.2 and 5.3			
BIOMARKER SET	ACCURACY	SPECIFICITY	SENSISTIVITY
TIMP1, IRAK2, TIFA, VNN1, OSM, ITGAM			
SOCS3, IL1RN, CEACAM1, FCGR1A, LDLR, CCL5, CReactiveProtein, AlphaFetoprotein, ARG2, IL6, CD86, MCP1, INSL3, IL18R1	0.82	0.85	0.79
ANKRD22, FAD104, ApolipoproteinCIII, IRAK2, TNFSF13B, TGFBI, TLR4, CRTAP, MCP1, LDLR, JAK2, SOD2, PSTPIP2, Protein_MMP9	0.82	0.84	0.79
BCL2A1, IL1RN, FCGR1A, GADD45A, JAK2, NCR1, TDRD9, TIFA, TNFSF10, Protein_MMP9, CRTAP, CSF1R, IL6, INSL3	0.82	0.84	0.79
SOD2, ITGAM, ApolipoproteinCIII, ANXA3, FAD104, IL6, ARG2, CD86, TGFBI, SOCS3, OSM, TDRD9, IL18R1, LY96	0.82	0.8	0.83
VNN1, IRAK2, ApolipoproteinCIII, IL10, TDRD9, FCGR1A, IL8, TIMP1, MCP1, JAK2, TIFA, TGFBI, OSM, MAPK14	0.82	0.79	0.84
ApolipoproteinCIII, IL10, TDRD9, ARG2, IRAK4, ANXA3, TNFRSF6, CReactiveProtein, INSL3, JAK2, IL1RN, IL6, NCR1, Gene_MMP9	0.82	0.78	0.85
CD86, CSF1R, TNFSF13B, FCGR1A, MCP1, GADD45A, LDLR, IRAK2, CCL5, Beta2Microglobulin, SOCS3, MAP2K6, LY96, INSL3	0.81	0.83	0.79
MCP1, NCR1, TGFBI, TDRD9, MAP2K6, ApolipoproteinCIII, INSL3, LY96, IFNGR1, JAK2, Protein_MMP9, GADD45B, IRAK4, CCL5	0.81	0.83	0.8
Beta2Microglobulin, FCGR1A, TNFSF13B, OSM, IRAK4, IRAK2, IL8, MAPK14, PSTPIP2, TIFA, TIMP1, ApolipoproteinCIII, MAP2K6, TLR4	0.81	0.82	0.8
TNFSF13B, LY96, OSM, MAP2K6, IRAK2, CRTAP, JAK2, PFKFB3, BCL2A1, CReactiveProtein, INSL3, GADD45A, TIFA, IL10alpha	0.81	0.82	0.81
OSM, JAK2, GADD45A, CEACAM1, ARG2, NCR1, TLR4, PRV1, PFKFB3, IL8, Beta2Microglobulin, GADD45B, HLA-DRA, INSL3	0.81	0.82	0.81
LY96, TIFA, CSF1R, IL10, SOCS3, ARG2, IRAK4, CD86, IL10alpha, Protein_MMP9, TNFSF10, ITGAM, Gene_MMP9, LDLR	0.81	0.79	0.83
AlphaFetoprotein, ApolipoproteinCIII, SOD2, PSTPIP2, CSF1R, Beta2Microglobulin, NCR1, GADD45B, FCGR1A, CReactiveProtein, CEACAM1, CD86, Protein_MMP9, HLA-DRA	0.81	0.78	0.84
MAPK14, ARG2, TNFSF10, TNFSF13B, FAD104, ANKRD22, GADD45A, ANXA3, CReactiveProtein, NCR1, IFNGR1, OSM, Protein_MMP9, IL18R1	0.81	0.74	0.88
VNN1, NCR1, IL10alpha, ARG2, IL6, LY96, CReactiveProtein, JAK2, TGFBI, SOCS3, CRTAP, ITGAM, IRAK4, PRV1	0.81	0.84	0.79
TNFSF13B, CReactiveProtein, INSL3, CEACAM1, Beta2Microglobulin, CD86, IL6, JAK2, ApolipoproteinCIII, IL18R1, ANXA3, PSTPIP2, SOD2, IL1RN	0.81	0.78	0.84
IRAK2, FCGR1A, Gene_MMP9, BCL2A1, TGFBI, PSTPIP2, CEACAM1, GADD45A, CCL5, TNFSF13B, ARG2, IL8, TIFA, IL18R1	0.81	0.78	0.84

[0440] In some embodiments, the methods or kits respectively described or referenced in Section 5.2 and Section 5.3 use any one of the subsets of biomarkers listed in Table O. The subsets of biomarkers listed in Table O were identified in the computational experiments described in Section 6.14.5, below, in which 4600 random subcombinations of the biomarkers listed in Table I were tested. Table O lists some of the biomarker sets that provided high accuracy scores against the validation population described in Section 6.14.5. Each row of Table O lists a single set of biomarkers that can be used in the methods and kits respectively referenced in Sections 5.2 and 5.3. In other words, each row of Table O describes a set of biomarkers that can be used to discriminate between sepsis and SIRS subjects. In some embodiments, nucleic acid forms of the biomarkers listed in Table O are used in the methods

and kits respectively referenced in Sections 5.2 and 5.3. In some embodiments, protein forms of the biomarkers listed in Table O are used. In some embodiments, some of the biomarkers in a biomarker set from Table O are in protein form and some of the biomarkers in the same biomarker set from Table O are in nucleic acid form in the methods and kits respectively referenced in Sections 5.2 and 5.3.

[0441] In some embodiments, a given set of biomarkers from Table O is used with the addition of one, two, three, four, five, six, seven, eight, or nine or more additional biomarkers from any one of Table 30, 31, 32, 33, 34, or 36 that are not within the given set of biomarkers from Table O. In Table O, accuracy, specificity, and sensitivity are described with reference to T₋₃₆ time point data described in Section 6.14.6, below.

TABLE O

Exemplary sets of biomarkers used in the methods or kits referenced in Sections 5.2 and 5.3			
BIOMARKER SET	ACCURACY	SPECIFICITY	SENSITIVITY
SOCS3, ApolipoproteinCIII, NCR1	0.81	0.75	0.85
IL8, PRV1, CEACAM1	0.8	0.79	0.8
PSTPIP2, TLR4, GADD45B	0.8	0.72	0.87
ARG2, PRV1, MKNK1	0.79	0.71	0.85
CD86, SOCS3, TLR4	0.79	0.74	0.82
PRV1, GADD45B, TNFSF13B, ITGAM	0.83	0.73	0.91
PRV1, ApolipoproteinCIII, FCGR1A, LDLR	0.81	0.78	0.84
TNFRSF6, MAP2K6, PRV1, ANKRD22	0.81	0.77	0.85
PRV1, ARG2, CD86, CEACAM1	0.81	0.8	0.82
GADD45B, CReactiveProtein, PRV1, CD86	0.81	0.73	0.88
GADD45B, TNFSF13B, FAD104, PFKFB3	0.81	0.73	0.86
PRV1, FAD104, IL18R1, MCP1	0.8	0.69	0.88
PRV1, IRAK2, PSTPIP2, ANXA3	0.8	0.68	0.87
FCGR1A, JAK2, MKNK1, PRV1	0.8	0.65	0.91
IL10, TNFSF13B, GADD45B, CEACAM1	0.79	0.73	0.85
Beta2Microglobulin, GADD45B, ARG2, TNFSF13B, OSM	0.81	0.73	0.88
CD86, BCL2A1, PSTPIP2, PRV1, JAK2	0.8	0.71	0.89
GADD45A, GADD45B, CSF1R, MAP2K6, PSTPIP2	0.8	0.69	0.88
AlphaFetoprotein, CReactiveProtein, GADD45B, MAPK14, ANXA3	0.8	0.76	0.82
PRV1, FCGR1A, NCR1, CReactiveProtein, TNFRSF6	0.8	0.74	0.84
MAPK14, CSF1R, OSM, IL1RN, TLR4	0.8	0.74	0.84
IRAK4, MAPK14, GADD45B, TNFSF13B, CSF1R	0.8	0.71	0.86
ITGAM, ANXA3, Beta2Microglobulin, PRV1, IRAK2	0.79	0.76	0.82
NCR1, MCP1, PRV1, CD86, FCGR1A	0.79	0.72	0.86
CRTAP, Beta2Microglobulin, TDRD9, GADD45A, PRV1	0.79	0.65	0.91
PRV1, PFKFB3, FCGR1A, TIFA, ANKRD22	0.79	0.73	0.84
PRV1, ApolipoproteinCIII, FCGR1A, Protein_MMP9, TIMP1	0.79	0.72	0.85
FCGR1A, IRAK2, TNFSF13B, OSM, CRTAP, PFKFB3	0.84	0.79	0.89
ANXA3, CEACAM1, PRV1, OSM, MCP1, CCL5	0.81	0.77	0.84
IRAK4, TNFSF10, MCP1, PRV1, MKNK1, SOCS3	0.81	0.75	0.84
TGFBI, CEACAM1, CD86, MAPK14, LDLR, PRV1	0.8	0.76	0.83
MCP1, GADD45B, CEACAM1, TIMP1, MAP2K6, IFNGR1	0.8	0.76	0.83
LY96, PRV1, MCP1, IRAK2, CD86, TNFSF10	0.8	0.76	0.83
BCL2A1, PRV1, LDLR, TNFSF10, IL18R1, SOCS3	0.8	0.73	0.85

TABLE O-continued

Exemplary sets of biomarkers used in the methods or kits referenced in Sections 5.2 and 5.3			
BIOMARKER SET	ACCURACY	SPECIFICITY	SENSITIVITY
SOCS3, ApolipoproteinCIII, FCGR1A, TNFSF13B, IFNGR1, Beta2Microglobulin	0.79	0.7	0.87
ARG2, PSTPIP2, TNFRSF6, GADD45B, MAPK14, TIMP1	0.79	0.82	0.77
NCR1, IL8, FCGR1A, IL1RN, ApolipoproteinCIII, IFNGR1	0.79	0.73	0.84
LDLR, MAP2K6, PRV1, TIMP1, HLA- DRA, CCL5	0.79	0.72	0.85
TIFA, GADD45B, HLA-DRA, CEACAM1, OSM, ARG2	0.79	0.74	0.83
TIMP1, GADD45A, MKNK1, SOCS3, LDLR, TNFSF10	0.79	0.73	0.83
SOD2, LY96, PRV1, FAD104, BCL2A1, GADD45A	0.79	0.72	0.83
CEACAM1, BCL2A1, IRAK4, LDLR, TIFA, IL10alpha	0.79	0.69	0.85
TNFSF10, TIFA, GADD45B, ANXA3, BCL2A1, TNFRSF6	0.78	0.65	0.88
Beta2Microglobulin, TIMP1, GADD45A, CRTAP, FAD104, GADD45B	0.78	0.79	0.77
ApolipoproteinCIII, IL18R1, CSF1R, LDLR, FCGR1A, MCP1	0.78	0.72	0.83
MKNK1, GADD45B, IL1RN, NCR1, IL10, LDLR	0.78	0.71	0.83
CD86, IL10, IFNGR1, SOCS3, TDRD9, MCP1	0.78	0.7	0.85
PRV1, SOD2, INSL3, TIFA, IRAK2, MCP1	0.78	0.7	0.84
AlphaFetoprotein, Protein_MMP9, ANKRD22, HLA-DRA, MAP2K6, GADD45B, CEACAM1	0.83	0.79	0.87
TNFSF13B, OSM, PRV1, CSF1R, IFNGR1, TNFRSF6, FCGR1A	0.83	0.79	0.85
FCGR1A, CCL5, TNFSF13B, Gene_MMP9, IL6, MAP2K6, OSM	0.81	0.83	0.8
GADD45B, IL1RN, Beta2Microglobulin, VNN1, PRV1, CD86, IL10	0.81	0.68	0.91
IL8, TIFA, IL18R1, SOD2, CSF1R, FAD104, PRV1	0.8	0.81	0.8
MAP2K6, SOD2, IL18R1, LDLR, ANXA3, CD86, GADD45B	0.8	0.78	0.82
ANKRD22, PRV1, TIMP1, NCR1, GADD45A, FCGR1A, TNFSF13B	0.8	0.75	0.84
IL10alpha, CRTAP, IL10, TIMP1, TIFA, PRV1, ARG2	0.8	0.73	0.87
TNFRSF6, TLR4, LY96, CSF1R, GADD45B, CCL5, INSL3	0.8	0.7	0.88
TDRD9, ANXA3, TNFSF10, TNFRSF6, PRV1, CCL5, IFNGR1	0.8	0.68	0.9
CD86, GADD45B, CReactiveProtein, LDLR, CCL5, FAD104, IL8	0.8	0.82	0.78
IRAK4, TGFB1, PRV1, CEACAM1, IFNGR1, PSTPIP2, TLR4	0.8	0.75	0.83
OSM, Gene_MMP9, TLR4, TDRD9, CCL5, CRTAP, HLA-DRA	0.8	0.72	0.84
CRTAP, CEACAM1, FAD104, GADD45A, PRV1, MAP2K6, TNFSF10	0.79	0.72	0.84
TNFRSF6, MKNK1, SOD2, TGFB1, MCP1, GADD45B, ANKRD22	0.79	0.72	0.86
TIMP1, BCL2A1, TNFSF10, PRV1, HLA- DRA, CRTAP, PFKFB3	0.79	0.7	0.86
INSL3, ANXA3, Beta2Microglobulin, GADD45B, TNFRSF6, ANKRD22, LDLR	0.79	0.7	0.86
TIFA, GADD45B, HLA-DRA, CD86, IL10, IL10alpha, MCP1	0.79	0.72	0.83
FCGR1A, CReactiveProtein, BCL2A1, GADD45B, PRV1, PFKFB3, MAP2K6	0.79	0.71	0.83
IL8, INSL3, ANKRD22, TNFSF10, HLA- DRA, PFKFB3, CSF1R	0.79	0.7	0.85
IL10alpha, MCP1, SOD2, TNFSF13B, CRTAP, MAP2K6, PRV1	0.78	0.75	0.81

TABLE O-continued

Exemplary sets of biomarkers used in the methods or kits referenced in Sections 5.2 and 5.3			
BIOMARKER SET	ACCURACY	SPECIFICITY	SENSITIVITY
FAD104, SOD2, LY96, IL8, IRAK4, PRV1, Protein_MMP9	0.78	0.73	0.83
MAPK14, OSM, PRV1, CRTAP, IL10alpha, MKNK1, IFNGR1	0.78	0.7	0.85
OSM, AlphaFetoprotein, IFNGR1, SOD2, GADD45A, CEACAM1, MKNK1	0.78	0.73	0.82
IL18R1, TDRD9, INSL3, JAK2, Protein_MMP9, TNFRSF6, NCR1	0.78	0.7	0.85
IFNGR1, CEACAM1, JAK2, SOD2, HLA- DRA, MAPK14, PRV1, VNN1	0.83	0.82	0.84
NCR1, IRAK2, MAP2K6, CReactiveProtein, FCGR1A, ARG2, CD86, SOCS3	0.83	0.83	0.82
GADD45B, ARG2, GADD45A, IL10alpha, TDRD9, PFKFB3, CReactiveProtein, OSM	0.81	0.75	0.84
PRV1, ITGAM, IL1RN, MAPK14, TNFSF10, SOD2, ARG2, PFKFB3	0.81	0.74	0.85
TNFRSF6, Beta2Microglobulin, PSTPIP2, IL8, SOCS3, GADD45B, CRTAP, IFNGR1	0.81	0.73	0.87
CReactiveProtein, LY96, MAP2K6, IL18R1, INSL3, OSM, CSF1R, IL6	0.8	0.78	0.82
ITGAM, PRV1, MAP2K6, IL8, OSM, SOD2, IRAK4, CCL5	0.8	0.74	0.86
CReactiveProtein, OSM, PSTPIP2, TNFSF10, ANKRD22, TDRD9, INSL3, CD86	0.8	0.73	0.85
ANKRD22, CD86, PRV1, ANXA3, IL10, TNFSF13B, TIFA, AlphaFetoprotein	0.79	0.81	0.78
ApolipoproteinCIII, MKNK1, FCGR1A, PSTPIP2, VNN1, TNFRSF6, AlphaFetoprotein, OSM	0.79	0.75	0.82
PRV1, CCL5, PFKFB3, TNFSF13B, TIMP1, LDLR, ANKRD22, MAP2K6	0.79	0.74	0.83
ARG2, VNN1, ANKRD22, IFNGR1, IL1RN, CD86, FAD104, GADD45B	0.79	0.74	0.85
IL10, PFKFB3, NCR1, TNFSF13B, MCP1, MAPK14, PRV1, TIMP1	0.79	0.7	0.86
ApolipoproteinCIII, INSL3, IL10alpha, FCGR1A, IL1RN, IL6, TNFRSF6, IL8	0.79	0.74	0.83
IL10, FAD104, CCL5, SOCS3, CD86, HLA-DRA, LDLR, GADD45A	0.79	0.79	0.78
PFKFB3, CReactiveProtein, MAPK14, TNFSF10, BCL2A1, ITGAM, IL10alpha, TDRD9	0.79	0.74	0.81
Beta2Microglobulin, TNFSF13B, ANKRD22, MCP1, TDRD9, IRAK4, TIMP1, OSM	0.78	0.73	0.82
PSTPIP2, MAP2K6, AlphaFetoprotein, TDRD9, PFKFB3, IL8, ANXA3, PRV1	0.78	0.69	0.84
TIFA, AlphaFetoprotein, PRV1, IL18R1, Gene_MMP9, VNN1, TDRD9, TNFRSF6	0.78	0.68	0.87
IRAK2, FAD104, PRV1, GADD45A, TIFA, MCP1, TIMP1, SOD2	0.78	0.72	0.83
IL6, CSF1R, MAP2K6, ANXA3, MCP1, PRV1, ITGAM, AlphaFetoprotein	0.78	0.72	0.82
CCL5, IL10alpha, GADD45B, LDLR, PSTPIP2, CD86, HLA-DRA, TLR4	0.78	0.69	0.84
LDLR, CRTAP, NCR1, TNFRSF6, ApolipoproteinCIII, MAPK14, FCGR1A, IRAK2	0.78	0.69	0.84
TGFBI, ANXA3, IL18R1, MAP2K6, FCGR1A, IL10, OSM, PRV1	0.78	0.67	0.87
NCR1, JAK2, ANKRD22, IL1RN, ANXA3, LDLR, CD86, IFNGR1, OSM	0.82	0.78	0.86
CSF1R, TDRD9, FAD104, TNFSF10, OSM, LDLR, MAPK14, TIFA, BCL2A1	0.82	0.79	0.84
TNFSF10, IFNGR1, TNFRSF6, GADD45B, CCL5, TNFSF13B, ANXA3, JAK2, PRV1	0.82	0.75	0.87
TNFSF13B, CD86, TIFA, SOCS3, GADD45B, ARG2, TNFSF10, IRAK4, IL10	0.81	0.68	0.91

TABLE O-continued

Exemplary sets of biomarkers used in the methods or kits referenced in Sections 5.2 and 5.3			
BIOMARKER SET	ACCURACY	SPECIFICITY	SENSITIVITY
FCGR1A, PSTPIP2, CEACAM1, IL1RN, FAD104, IL6, INSL3, CSF1R, PRV1	0.81	0.79	0.83
IL1RN, SOD2, TGFBI, ApolipoproteinCIII, JAK2, CEACAM1, IRAK2, IFNGR1, OSM	0.8	0.83	0.78
TDRD9, CD86, Protein_MMP9, TNFRSF6, SOCS3, MCP1, AlphaFetoprotein, TIFA, INSL3	0.8	0.78	0.82
BCL2A1, TGFBI, TLR4, IL8, LDLR, ANKRD22, TNFSF13B, IL10, GADD45B	0.8	0.77	0.83
TNFSF13B, AlphaFetoprotein, TDRD9, MAPK14, SOCS3, ANXA3, IL1RN, CRTAP, TNFRSF6	0.8	0.73	0.86
IL6, TNFRSF6, MCP1, JAK2, GADD45A, TIFA, ARG2, FCGR1A, ANKRD22	0.8	0.75	0.84
PSTPIP2, ANXA3, MCP1, FAD104, PRV1, ANKRD22, NCR1, HLA-DRA, FCGR1A	0.8	0.73	0.86
IL8, PRV1, TDRD9, Beta2Microglobulin, IL10alpha, VNN1, INSL3, TIFA, CSF1R	0.8	0.73	0.86
GADD45B, TNFRSF6, OSM, IRAK4, AlphaFetoprotein, IL1RN, TNFSF13B, MCP1, FAD104	0.8	0.71	0.88
ANKRD22, OSM, INSL3, IFNGR1, MKNK1, GADD45B, TDRD9, MAP2K6, IRAK4	0.8	0.69	0.89
NCR1, JAK2, ANKRD22, IL1RN, ANXA3, LDLR, CD86, IFNGR1, OSM	0.82	0.78	0.86
ApolipoproteinCIII, ANXA3, IL18R1, PRV1, CD86, LDLR, TDRD9, CReactiveProtein, MAP2K6, CSF1R, CRTAP	0.84	0.73	0.93
CCL5, Protein_MMP9, NCR1, PRV1, TNFRSF6, TGFBI, HLA-DRA, FCGR1A, IFNGR1, CSF1R, MCP1	0.82	0.74	0.88
GADD45B, CSF1R, IL1RN, PSTPIP2, PRV1, ApolipoproteinCIII, ARG2, SOCS3, FAD104, ITGAM, TIMP1	0.81	0.81	0.81
JAK2, MKNK1, CRTAP, GADD45B, OSM, INSL3, TIMP1, TIFA, TNFRSF6, AlphaFetoprotein, CD86	0.81	0.79	0.83
ApolipoproteinCIII, CD86, FCGR1A, ARG2, GADD45B, IL8, CRTAP, IFNGR1, TIMP1, ANXA3, HLA-DRA	0.81	0.73	0.88
MCP1, IL8, TNFSF13B, AlphaFetoprotein, LDLR, Protein_MMP9, JAK2, FAD104, IRAK2, TNFRSF6, GADD45B	0.81	0.78	0.83
TLR4, NCR1, CCL5, IL6, CReactiveProtein, IRAK4, AlphaFetoprotein, FCGR1A, ApolipoproteinCIII, GADD45B, PRV1	0.81	0.76	0.85
ANKRD22, OSM, VNN1, LDLR, ApolipoproteinCIII, IL1RN, SOCS3, MAPK14, GADD45B, JAK2, ITGAM	0.8	0.81	0.8
NCR1, ARG2, GADD45B, GADD45A, CD86, TNFSF10, CCL5, PSTPIP2, Beta2Microglobulin, CRTAP, LDLR	0.8	0.76	0.84
SOCS3, JAK2, IL1RN, IFNGR1, CRTAP, TIMP1, Protein_MMP9, VNN1, TNFRSF6, CD86, ANKRD22	0.8	0.76	0.84
OSM, PSTPIP2, IL1RN, AlphaFetoprotein, PRV1, IL6, LY96, IL18R1, CSF1R, TNFSF13B, LDLR	0.8	0.86	0.75
IL10alpha, CReactiveProtein, TIFA, NCR1, CRTAP, TGFBI, PFKFB3, LDLR, IRAK4, GADD45B, TDRD9	0.8	0.75	0.84
ApolipoproteinCIII, ANXA3, IL18R1, PRV1, CD86, LDLR, TDRD9, CReactiveProtein, MAP2K6, CSF1R, CRTAP	0.84	0.73	0.93

[0442] In some embodiments, the methods or kits respectively described or referenced in Section 5.2 and Section 5.3 use at least two different biomarkers that each contain a probeset listed in any one of FIG. 6, 14, 17, or 26. In a particular embodiment, a biomarker profile comprises at least two different biomarkers that each contain one of the probesets listed in any one of FIG. 6, 14, 17, or 26, biomarkers that each contain the complement of one of the probesets of any one of FIG. 6, 14, 17, or 26, or biomarkers that each contain an amino acid sequence encoded by a gene that either contains one of the probesets of any one of FIG. 6, 14, 17, or 26, or the complement of one of the probesets of any one of FIG. 6, 14, 17, or 26. Such biomarkers can be, for example, mRNA transcripts, cDNA or some other nucleic acid, for example, amplified nucleic acid, or proteins. The biomarker profile further comprises a respective corresponding feature for the at least two biomarkers. Generally, the at least two biomarkers are derived from at least two different genes. In the case where a biomarker is based upon a gene that includes the sequence of a probeset listed in any one of FIG. 6, 14, 17, or 26, the biomarker can be, for example, a transcript made by the gene, a complement thereof, or a discriminating fragment or complement thereof, or a cDNA thereof, or a discriminating fragment of the cDNA, or a discriminating amplified nucleic acid molecule corresponding to all or a portion of the transcript or its complement, or a protein encoded by the gene, or a discriminating fragment of the protein, or an indication of any of the above. Further still, the biomarker can be, for example, a protein encoded by a gene that includes a probeset sequence described in any one of FIG. 6, 14, 17, or 26, or a discriminating fragment of the protein, or an indication of any of the above. Here, a discriminating molecule or fragment is a molecule or fragment that, when detected, indicates presence or abundance of the above-identified transcript, cDNA, amplified nucleic acid, or protein. In some embodiments, the biomarker profile comprises at least 2, 3, 4, 5, 6, 7, 8, 9, or 10 different biomarkers that each contains a probeset listed in any one of FIG. 6, 14, 17, or 26.

[0443] In some embodiments, the methods or kits respectively described or referenced in Section 5.2 and Section 5.3 use at least two different biomarkers listed in any one of FIG. 39, 43, 52, 53, or 56. In a particular embodiment, the biomarker profile comprises at least two different biomarkers listed in any one of FIG. 39, 43, 52, 53, or 56. The biomarker profile further comprises a respective corresponding feature for the at least two biomarkers. Generally, the at least two biomarkers are derived from at least two different genes. In the case where a biomarker in the at least two different biomarkers is listed in any one of FIG. 39, 43, 52, 53, or 56, the biomarker can be, for example, a transcript made by the listed gene, a complement thereof, or a discriminating fragment or complement thereof, or a cDNA thereof, or a discriminating fragment of the cDNA, or a discriminating amplified nucleic acid molecule corresponding to all or a portion of the transcript or its complement, or a protein encoded by the gene, or a discriminating fragment of the protein, or an indication of any of the above. Further still, the biomarker can be, for example, a protein encoded by a gene listed in any one of FIG. 39, 43, 52, 53, or 56, or a discriminating fragment of the

protein, or an indication of any of the above. Here, a discriminating molecule or fragment is a molecule or fragment that, when detected, indicates presence or abundance of the above-identified transcript, cDNA, amplified nucleic acid, or protein. In accordance with this embodiment, the biomarker profiles of the present invention can be obtained using any standard assay known to those skilled in the art, or in an assay described herein, to detect a biomarker. Such assays are capable, for example, of detecting the products of expression (e.g., nucleic acids and/or proteins) of a particular gene or allele of a gene of interest (e.g., a gene disclosed in Table 30). In one embodiment, such an assay utilizes a nucleic acid microarray. In some embodiments, the biomarker profile comprises at least two different biomarkers from any one of FIG. 39, 43, 52, 53, or 56. In some embodiments, the biomarker profile comprises at least 2, 3, 4, 5, 6, 7, 8, 9, 10, 11, 12, 13, 14, 15, 16, 17, 18, 19, or 20 different biomarkers from any one of FIG. 39, 43, 52, 53, or 56.

[0444] In some embodiments, the methods or kits respectively described or referenced in Section 5.2 and Section 5.3 use specific biomarkers containing probes from any one of the probeset collections listed in Table P. In a particular embodiment, a biomarker profile comprises at least two different biomarkers that each contain one of the probesets listed in any one of the probeset collections of Table P, biomarkers that each contain the complement of one of the probesets from any one of the probeset collections of Table P, or biomarkers that each contain an amino acid sequence encoded by a gene that either contains one of the probesets from any one of the probeset collections of Table P, or the complement of one of the probesets of any one of the probeset collections of Table P. Such biomarkers can be, for example, mRNA transcripts, cDNA or some other nucleic acid, for example, amplified nucleic acid, or proteins. The biomarker profile further comprises a respective corresponding feature for the at least two biomarkers. Generally, the at least two biomarkers are derived from at least two different genes. In the case where a biomarker is based upon a gene that includes the sequence of a probeset listed in any one of the probeset collections of Table P, the biomarker can be, for example, a transcript made by the gene, a complement thereof, or a discriminating fragment or complement thereof, or a cDNA thereof, or a discriminating fragment of the cDNA, or a discriminating amplified nucleic acid molecule corresponding to all or a portion of the transcript or its complement, or a protein encoded by the gene, or a discriminating fragment of the protein, or an indication of any of the above. Further still, the biomarker can be, for example, a protein encoded by a gene that includes a probeset sequence from any one of the probeset collections listed in Table P, or a discriminating fragment of the protein, or an indication of any of the above. Here, a discriminating molecule or fragment is a molecule or fragment that, when detected, indicates presence or abundance of the above-identified transcript, cDNA, amplified nucleic acid, or protein. In some embodiments, the biomarker profile comprises at least 2, 3, 4, 5, 6, 7, 8, 9, or 10 different biomarkers that each contains a probeset from any one of probeset collections listed in Table P.

TABLE P

Exemplary probesets	
PROBESET COLLECTION	IDENTITY OF PROBE IN PROBESET COLLECTION
1	X206513_at, X214681_at, X235359_at, X221850_x_at, X213524_s_at, X225656_a, X200881_s_at, X229743_at, X215178_x_at, X215178_x_at, X216841_s_at, X216841_at, X244158_at, X238858_at, X205287_s_at, X233651_s_at, X229572_at, X214765_s_at.
2	X206513_at, X213524_s_at, X200881_s_at, X218992_at, X238858_at, X221123_x_at, X228402_at, X230585_at, X209304_x_at, X214681_at.
3	X204102_s_at, X236013_at, X213668_s_at, X1556639_at, X218220_at, X207860_at, X232422_at, X218578_at, X205875_s_at, X226043_at, X225879_at, X224618_at, X216316_x_at, X243159_x_at, X202200_s_at, X201936_s_at, X242492_at, X216609_at, X214328_s_at, X228648_at, X223797_at, X225622_at, X205988_at, X201978_s_at, X200874_s_at, X210105_s_at, X203913_s_at, X204225_at, X227587_at, X220865_s_at, X206682_at, X222664_at, X212264_s_at, X219669_at, X221971_x_at, X1554464_a_at, X242590_at, X227925_at, X221926_s_at, X202101_s_at, X211078_s_at, X44563_at, X206513_at, X215178_x_at, X235359_at, X225656_at, X244158_at, X214765_s_at, X229743_at, X214681.

[0445] In some embodiments, the methods or kits respectively described or referenced in Section 5.2 and Section 5.3 use at least two different biomarkers listed in any one of the biomarker sets in Table Q. In a particular embodiment, the biomarker profile comprises at least two different biomarkers listed in any one of the biomarker sets in Table Q. The biomarker profile further comprises a respective corresponding feature for the at least two biomarkers listed in any of the biomarker sets in Table Q. Generally, the at least two biomarkers are derived from at least two different genes. In the case where a biomarker in the at least two different biomarkers is listed in any one of biomarker sets of Table Q, the biomarker can be, for example, a transcript made by the listed gene, a complement thereof, or a discriminating fragment or complement thereof, or a cDNA thereof, or a discriminating frag-

molecule or fragment is a molecule or fragment that, when detected, indicates presence or abundance of the above-identified transcript, cDNA, amplified nucleic acid, or protein. In accordance with this embodiment, the biomarker profiles of the present invention can be obtained using any standard assay known to those skilled in the art, or in an assay described herein, to detect a biomarker. Such assays are capable, for example, of detecting the products of expression (e.g., nucleic acids and/or proteins) of a particular gene or allele of a gene of interest (e.g., a gene disclosed in any one of the biomarker sets of Table Q). In one embodiment, such an assay utilizes a nucleic acid microarray. In some embodiments, a biomarker profile comprising at least 2 or 3 different biomarkers from any one of the biomarker sets of Table Q is used.

TABLE Q

Exemplary biomarker sets	
BIOMARKER SET NUMBER	IDENTITY OF BIOMARKERS
1	IL18R1, ARG2, FCGR1A
2	ITGAM, TGFB1, TLR4, TNFSF, FCGR1A, IL18R1, ARG2
3	ARG2, TGFB1, MMP9, TLR4, ITGAM, IL18R1, TNFSF, IL1RN, FCGR1A
4	OSM, GADD45B, ARG2, IL18R1, TDRD9, PFKFB3, MAPK14, PRV1, MAP2K6, TNFRSF6, FCGR1A, INSL3, LY96, PSTPIP2, ANKRD22, TNFSF10, HLA-DRA, FNDC3B, TIFA, GADD45A, VNN1, ITGAM, BCL2A1, TLR4, TNFSF13B, SOCS3, IL1RN, CEACAM1, SOD2
5	ARG2, GADD45B, OSM, LY96, INSL3, ANKRD22, MAP2K6, PSTPIP2, TGFB1, GADD45B, TDRD9, MAP2K6, OSM, TNFSF10, ANKRD22

ment of the cDNA, or a discriminating amplified nucleic acid molecule corresponding to all or a portion of the transcript or its complement, or a protein encoded by the gene, or a discriminating fragment of the protein, or an indication of any of the above. Further still, the biomarker can be, for example, a protein encoded by a gene listed in any one of the biomarker sets in Table Q, or a discriminating fragment of the protein, or an indication of any of the above. Here, a discriminating

6. EXAMPLES

[0446] The following examples are representative of the embodiments encompassed by the present invention and in no way limit the subject embraced by the present invention. In the following examples, data was collected at twenty-four hour time intervals from each subject in a population of subjects. The population included two subject types. The first

subject type was those that initially had SIRS and developed sepsis at a terminal time point in the analysis. The second subject type was those that initially had SIRS and did not develop sepsis at the terminal time point in the analysis. For subjects that initially had SIRS and developed sepsis, a T_{-12} time point was defined as the time frame immediate prior to the onset of clinically-diagnosed sepsis. In practice, the T_{-12} time point for each respective sepsis subject was the day the last blood sample was collected from the respective subject prior to being diagnosed with sepsis.

[0447] For each time point, two types of analyses were performed, a static and a baseline analysis. In the static analysis, only data from a single time point was considered. In particular, univariate and/or multivariate techniques were used to identify biomarkers whose abundance on corresponding microarray probesets on the U133 plus 2.0 (Affymetrix, Santa Clara, Calif.) discriminate between those subjects that develop sepsis from those subjects that do not develop sepsis during the study. To illustrate, consider the case in which there are two subjects in the population, subject A, who develops sepsis shortly after time period T_{-12} , and subject B, who does not develop sepsis in any of the observed time points. In the static analysis, microarray biomarker abundance data from the two subjects that was collected at a particular single time point is evaluated in order to identify those biomarkers that have different abundance levels in the two subjects, as determined by a U133 plus 2.0 microarray experiment. In fact, in the present examples, a whole population of subjects of type A and type B are evaluated and parametric and/or nonparametric statistical techniques are used to identify those biomarkers whose abundance levels discriminate between subjects that develop sepsis at some point during the observation period and subjects that do not develop sepsis during the observation period. Here, an observation period refers to a time period that was a matter of hours, days, or weeks.

[0448] In addition to static analyses, baseline analyses were performed in the examples below. In a baseline analysis, rather than identifying biomarkers whose corresponding features (e.g. abundance value) at a single time point discriminate between sepsis subjects (subjects that develop sepsis at some point during the observation time period) and subjects that do not develop sepsis during the observed time frame, biomarkers whose change in abundance value across two or more time points discriminates between the two population types were identified. For example, again consider subject A, who develops sepsis shortly after time period T_{-12} , and subject B, who does not develop sepsis in any of the observed time points. In the baseline analysis, what were needed are biomarker abundance values for each subject from two different time points (e.g., time point 1 and time point 2). For each respective biomarker considered, the difference in the abundance of the biomarker at the two different time points was computed. These differential abundances from each of the subjects is then used to determine which corresponding biomarkers, expressed as a differential between two different time points, discriminate between subjects that develop sepsis during the observation period and subjects that do not develop sepsis during the observation time period.

6.1 Data Collection

[0449] SIRS positive subjects admitted to an ICU were recruited for the study. Subjects were eighteen years of age or older and gave informed consent to comply with the study protocol. Subjects were excluded from the study if they were

(i) pregnant, (ii) taking antibiotics to treat a suspected infection, (iii) were taking systemic corticosteroids (total dosage greater than 100 mg hydrocortisone or equivalent in the past 48 hours prior to study entry), (iv) had a spinal cord injury or other illness requiring high-dose corticosteroid therapy, (v) pharmacologically immunosuppressed (e.g., azathioprine, methotrexate, cyclosporin, tacrolimus, cyclophosphamide, etanercept, anakinra, infliximab, leflunomide, mycophenolic acid, OKT3, pentoxifyllin, etc.), (vi) were an organ transplant recipient, (vii) had active or metastatic cancer, (viii) had received chemotherapy or radiation therapy within 8 weeks prior to enrollment, and/or (ix) had taken investigational use drugs within thirty days prior to enrollment.

[0450] In the study SIRS criteria were evaluated daily. APACHE II and SOFA scoring was performed following ICU admission. APACHE II is a system for rating the severity of medical illness. APACHE stands for "Acute Physiology And Chronic Health Evaluation," and is most frequently used to predict in-hospital death for patients in an intensive care unit. See, for example, Gupta et al., 2004, Indian Journal of Medical Research 119, 273-282, which is hereby incorporated herein by reference in its entirety. SOFA is a test to measure the severity of sepsis. See, for example, Vincent et al., 1996, Intensive Care Med. 22, 707-710, which is hereby incorporated herein by reference in its entirety. Patients were monitored daily for up to two weeks for clinical suspicion of sepsis including, but not limited to, any of the following signs and symptoms:

[0451] pneumonia: temperature $>38.3^{\circ}$ C. or $<36^{\circ}$ C.+white blood cell count (WBC) $>12,000/\text{mm}^3$ or $<4,000/\text{mm}^3$ +new-onset of purulent sputum+new or progressive infiltrate on chest radiograph (3 out of 4 findings);

[0452] wound infection: temperature $>38.3^{\circ}$ C. or $<36^{\circ}$ C.+pain+erythema+purulent discharge (3 out of 4 findings);

[0453] urinary tract infection: temperature $>38.3^{\circ}$ C. or WBC $>12,000/\text{mm}^3$ or $<4,000/\text{mm}^3$ +bacteruria and pyuria (>10 WBC/hpf or positive leukocyte esterase) (all findings);

[0454] line sepsis: temperature $>38.3^{\circ}$ C. or $<36^{\circ}$ C.+erythema/pain/purulence at catheter exit site (3 out of 4 findings, including fever);

[0455] intra-abdominal abscess: temperature $>38.3^{\circ}$ C. or $<36^{\circ}$ C.+WBC $>12,000/\text{mm}^3$ or $<4,000/\text{mm}^3$ +radiographic evidence of fluid collection (2 out of 3 criteria);

[0456] CNS Infection: temperature $>38.3^{\circ}$ C. or $<36^{\circ}$ C.+WBC $>12,000/\text{mm}^3$ or $<4,000/\text{mm}^3$ +CSF pleocytosis via LP or Ventricular drainage.

[0457] Blood was drawn daily for a minimum of four consecutive days beginning within 24 hours following study entry. Patients were followed and blood samples were drawn daily for a maximum of fourteen consecutive days unless clinical suspicion of infection occurred. The maximum volume of blood drawn from any one subject did not exceed 210 mL over the course of a 14 day study maximum. Blood draws for the study were discontinued if the loss of blood posed risk to the patient as defined by physician's judgment. Each patient had two Paxgene (RNA) tubes drawn on each day. One tube was used for the microarray analysis described in Section 6.2. The other tube was used for the RT-PCR analysis described in Section 6.10.

6.2 Microarray Analysis

[0458] RNA was extracted from each blood sample described in Section 6.1, labeled, reversed transcribed to gen-

erate cDNA which was labeled, and the labeled cDNA was hybridized to Affymetrix (Santa Clara, Calif.) U133 plus 2.0 human genome chips containing 54,675 probesets. To enhance detection sensitivity of the microarray, globin mRNA molecules were removed from the total RNA extracted from the blood samples using the methods described in, for example, U.S. Patent Publication 20050221310, filed Aug. 9, 2004, and 10/948,635, filed Sep. 24, 2004, both entitled "Methods of Enhancing Gene Expression Analysis," each of which is incorporated by reference herein in its entirety. The U133 plus 2.0 has 62 probesets designed for special functions, such as measuring supplementally added transcripts. This leaves 54,613 probesets designed specifically for the detection of human genes. The Affymetrix human genome U133 (HG-U133) set, consisting of two microarrays, contains almost 45,000 probesets representing more than 39,000 transcripts derived from approximately 33,000 human genes. This set design uses sequences selected from GenBank, dbEST, and RefSeq. As used herein, the abundance value measured for each of the biomarkers that bind to these probesets is referred to as a feature. The examples below discuss abundance values of biomarkers that bind to particular probesets in the U133 plus 2.0 human genome chip.

6.3 Static T_{-36} Data Analysis

[0459] In one experiment, a T_{-36} static analysis was performed. In the T_{-36} static analysis, biomarkers features are determined using a specific blood sample, designated the T_{-36} blood sample, from each subject in a training population. The identity of this specific blood sample from each respective subject in the training population is dependent upon whether the subject was a SIRS subject (did not develop sepsis during the observation period) or was a sepsis subject (did develop sepsis during the observation period). In the case of a sepsis subject, the T_{-36} sample is defined as the second to last blood sample taken from the subject before the subject acquired sepsis. Identification of T_{-36} samples in the SIRS subjects in the training population was more discretionary than for the sepsis counterpart subjects because there was no significant event in which the SIRS subjects became septic. Because of this, the identity of the T_{-36} samples for the sepsis subjects in the training population was used to identify the T_{-36} samples in the SIRS subjects in the training population. Specifically, T_{-36} time points (blood samples) for SIRS subjects in the training population were identified by "time-matching" a septic subject and a SIRS subject. For example, consider the case in which a subject that entered the study became clinically-defined as septic on their sixth day of enrollment. For this subject, T_{-36} is day four of the study, and the T_{-36} blood sample is the blood sample that was obtained on day four of the study. Likewise, T_{-36} for the SIRS subject that was matched to this sepsis subject is deemed to be day four of the study on this paired SIRS subject.

[0460] Although SIRS subjects did not progress on to develop sepsis, they did have changes in their expressed genes (and proteins, etc.) over time. Thus, a one-to-one time matching of sepsis subjects to SIRS subjects for the purpose of obtaining a relevant set of T_{-36} blood samples from the SIRS subjects was sought in the manner described above. Just as subjects who progressed to become septic did so at varying rates, this time matching was done to mimic feature variability in SIRS subjects. While time matching between arbitrary pairs of SIRS and sepsis subjects was done to identify T_{-36}

blood samples for as many of the SIRS subjects in the training population as possible, in some instances, T_{-36} samples from SIRS subjects had to be selected from time points based on sample availability.

[0461] For the T_{-36} static analysis there were 54,613 biomarkers measured on 84 samples for a total of 84 corresponding microarray experiments from 84 different subjects. Each sample was collected from a different subject in the population of 84 subject. Of the 54,613 probesets measured in each microarray experiment, 30,464 were transformed by log transformations. The log transformation is described in Draghici, 2003, *Data Analysis Tools for DNA Microarrays*, Chapman & Hall/CRC, Boca Raton, pp. 309-311, which is hereby incorporated by reference in its entirety. Further, of the 54,613 probesets in each microarray experiment, 2317 were transformed by a square root transformation. The square root transformation is described in Ramdas, 2001, *Genome Biology* 2, 47.1-47.7, which is hereby incorporated by reference in its entirety. The remaining 21,832 probesets in each microarray experiment were not transformed.

[0462] The 84 member population was initially split into a training set (n=64) and a validation set (n=20). The training set was used to estimate the appropriate classification algorithm parameters while the trained algorithm was applied to the validation set to independently assess performance. Of the 64 training samples, 35 were Sepsis, meaning that the subjects developed sepsis at some point during the observation time period, and 29 were SIRS, meaning that they did not develop sepsis during the observation time period. Table 1 provides distributions of the race, gender and age for these samples.

TABLE 1

Distributions of the race, gender, and age for the training data				
Group	Gender	Black	Caucasian	Other
Sepsis	Male	10	13	1
	Female	0	10	1
SIRS	Male	5	17	0
	Female	0	7	0
Group	Minimum	Mean	Median	Maximum
Sepsis	18	42	41	80
SIRS	18	43	40	90

[0463] For the 20 validation samples, 9 were Sepsis and 11 were SIRS. Table 2 provides distributions of the race, gender and age for these samples.

TABLE 2

Distributions of the race, gender, and age for the validation data				
Group	Gender	Black	Caucasian	Other
Sepsis	Male	1	7	0
	Female	0	3	0
SIRS	Male	0	6	0
	Female	0	3	0
Group	Minimum	Mean	Median	Maximum
Sepsis	18	41.8	43	81
SIRS	19	47.7	51	77

[0464] Each sample in the training data was randomly assigned to one of ten groups used for cross-validation. The number of training samples in these groups ranged from 6 to 7. The samples were assigned in way that attempted to balance the number of sepsis and SIRS samples across folds. As described in more detail below, several different methods were used to judge whether select biomarkers, which bind to

which is hereby incorporated by reference in its entirety. The biomarkers are ordered by their q-values and if a biomarker has a q-value of X, then this biomarker and all others more significant have a combined false discovery rate of X. However, the false discovery rate for any one biomarker may be much larger. There were 2431 significant markers using this method (see Table 3).

TABLE 3

	Cumulative number of significant calls for the three methods.						
	$\leq 1e-04$	≤ 0.001	≤ 0.01	≤ 0.025	≤ 0.05	≤ 0.1	≤ 1
p-value (unadjusted)	0	1362	4210	6637	9520	13945	54613
p-value (adjusted)	0	0	0	584	1618	3315	54613
q-value	0	0	0	1055	2431	4785	54613

Note that all 84 samples (training and validation) were used to compare converters and nonconverters. Missing biomarker values were not included in the analyses.

particular probesets in the microarray, discriminate between the Sepsis and SIRS groups.

[0465] Wilcoxon and Q-value tests. The first method used to identify discriminating biomarkers was a Wilcoxon test (unadjusted). The Wilcoxon test is a distribution-free test is resistant to extreme values. The Wilcoxon test is described in Agresti, 1996, *An Introduction to Categorical Data Analysis*, John Wiley & Sons, Inc, New York, Chapter 2, which is hereby incorporated by reference in its entirety. The Wilcoxon test produces a p value. The abundance value for a given biomarker from all samples in the training data is subjected to the Wilcoxon test. The Wilcoxon test considers both group classification (sepsis versus SIRS) and abundance value in order to compute a p value for the given biomarker. The p value provides an indication of how well the abundance value for the given biomarker across the samples collected in the training set discriminates between the sepsis and SIRS state. When the p value is less than a specific confidence level, such as 0.05, an inference is made that the biomarker discriminates between Sepsis and SIRS. There were 9520 significant biomarkers using this method (see Table 3).

[0466] The second method used to identify discriminating biomarkers was the Wilcoxon Test (adjusted). Due to the large number of biomarkers, 54613, and the relatively small number of samples, 84, there was a high risk of finding falsely significant biomarkers. An adjusted p-value was used to counter this risk. In particular, the method of Benjamini and Hochberg, 1995, J.R. Statist. Soc. B 57, pp 289-300, which is hereby incorporated by reference in its entirety, was used to control the false discovery rate. Here, the false discovery rate is defined as the number of biomarkers truly significant divided by the number of biomarkers declared significant. For example, if the adjusted p-value is less than 0.05, there is a 5% chance that the biomarker is a false discovery. Results using this test are reported in Table 3. There were 1618 significant biomarkers using this method (see Table 3). As used, herein, a biomarker is considered significant if the feature values corresponding to the biomarker have a p-value of less than 0.05 as determined by the Wilcoxon test (adjusted).

[0467] The third method used to identify discriminating biomarkers was the use of Q values. Q-values are described in Storey, 2002, J.R. Statist. Soc. B 64, Part 3, pp. 479-498,

[0468] CART. In addition to analyzing the microarray data using Wilcoxon test and Q-value tests in order to identify biomarkers that discriminate between the sepsis and SIRS subpopulations in the training set, classification and regression tree (CART) analysis was used. CART is described in Section 5.5.1, above. Specifically, the data summarized above was used to predict the disease state by iteratively partitioning the data based on the best single-variable (feature of biomarker across training set) split of the data. In other words, at each stage of the tree building process, the biomarker whose abundance value across the training population best discriminates between the sepsis and SIRS population was invoked as a decision branch. Cross-validation was carried out, with the optimal number of splits estimated independently in each of the 10 iterations. The final tree is depicted in FIG. 1. In FIG. 1, decision 102 makes a decision based on the abundance of the biomarker that binds to X204319_s_at. If the biomarker that binds to X204319_s_at has an abundance that is greater than 2.331 units in a biological sample from a subject to be diagnosed (test biological sample), then control passes to decision 104. If, on the other hand, the biomarker that binds to probe set X204319_s_at has abundance that is less than 2.331 units in the test biological sample, decision control passes to decision 106. Decisions are made in this manner until a terminal leaf of the decision tree is reached, at which point diagnoses of sepsis or SIRS is made. The decision tree in FIG. 1 makes use of the biomarkers that bind to the following five probesets: X204319_s_at, X1562290_at, X1552501_a_at, X1552283_s_at, and X117_at.

[0469] FIG. 2 shows the distribution of the biomarkers that bind to the five probesets used in the decision tree between the sepsis and SIRS groups in the training data set. In FIG. 2, the top of each box denotes the 75th percentile of the data across the training set and the bottom of each box denotes the 25th percentile, and the median value for each biomarker across the training set is drawn as a line within each box. The confusion matrix for the training data where the predicted classifications were made from the cross-validated model is given in Table 4. From this confusion matrix, the overall accuracy was estimated to be 70.3% with a 95% confidence interval of 57.6% to 81.1%. The estimated sensitivity was 60% and the estimated specificity was 82.8%.

TABLE 4

Confusion matrix for training samples using the cross-validated CART algorithm of FIG. 1.		
Predicted	True Diagnosis	
	Sepsis	SIRS
Sepsis	21	5
SIRS	14	24

[0470] For the 20 validation samples held back from training data set, the overall accuracy was estimated to be 70% with a 95% confidence interval of 45.7% to 88.1%, sensitivity 88.9% and specificity 54.5%. Table 5 shows the confusion matrix for the validation samples.

TABLE 5

Confusion matrix for validation samples using the cross-validated CART algorithm of FIG. 1.		
Predicted	True Diagnosis	
	Sepsis	SIRS
Sepsis	8	5
SIRS	1	6

[0471] Random Forests. Another decision rule that can be developed using biomarkers of the present invention is a Random Forests decision tree. Random Forests is a tree based method that uses bootstrapping instead of cross-validation. For each iteration, a random sample (with replacement) is drawn and the largest tree possible is grown. Each tree receives a vote in the final class prediction. To fit a random forest, the number of trees (e.g. bootstrap iterations) is specified. No more than 500 were used in this example, but at least 50 are needed for a burn-in period. The number of trees was chosen based on the accuracy of the training data. For this data, 500 trees were used to train the algorithm (see FIG. 3). In FIG. 3, curve 302 is a smoothed estimate of overall accuracy as a function of tree number. Curve 304 is a smoothed curve of tree sensitivity as a function of tree number. Curve 306 is a smoothed curve of tree specificity as a function of tree number. Using this algorithm, 901 biomarkers had non-zero importance and were used in the model. The random forest algorithm gauges biomarker importance by the average reduction in the training accuracy. The biomarkers were ranked by this method and are shown in FIG. 4. In FIG. 4, the biomarkers are labeled by the name of the U133 plus 2.0 probeset to which they bind. The figure only reflects the 50 most important biomarkers found by using Random Forest analysis. However, 901 biomarkers were actually found to have discriminating significance. The random forest method uses a number of different decision trees. A biomarker is considered to have discriminating significance if it served as a decision branch of a decision tree from a significant random forest analysis. As used herein, a significant random forest analysis is one where the lower 95% confidence interval on accuracy by cross validation on a training data set is greater than 50% and the point estimate for accuracy on a validation set is greater than 65%.

[0472] The predicted confusion matrix for the training dataset using the decision tree developed using the Random

Forest method is given in Table 6. From this confusion matrix, the overall accuracy was estimated to be 68.8% (confidence intervals cannot be computed when using the bootstrap accuracy estimate). The estimated sensitivity was 74.3% and the estimated specificity was 62.1%.

TABLE 6

Confusion matrix for training samples against the decision tree developed using the Random Forest method.		
Predicted	True Diagnosis	
	Sepsis	SIRS
Sepsis	18	9
SIRS	11	26

[0473] For the 20 validation samples held back from training, the overall accuracy was estimated to be 65% with a 95% confidence interval of 40.8% to 84.6%, sensitivity 66.7% and specificity 63.6%. Table 7 shows the confusion matrix for the validation samples.

TABLE 7

Confusion matrix for the 20 validation samples against the decision tree developed using the Random Forest method.		
Predicted	True Diagnosis	
	Sepsis	SIRS
Sepsis	6	4
SIRS	3	7

[0474] PAM. Yet another decision rule developed using the biomarkers of the present invention is predictive analysis of microarrays (PAM), which is described in Section 5.5.2, above. In this method, a shrinkage parameter that determines the number of biomarkers used to classify samples is specified. This parameter was chosen via cross-validation. There were no biomarkers with missing values. Based on cross-validation, the optimal threshold value was 2.07, corresponding to 258 biomarkers. FIG. 5 shows the accuracy across different thresholds. In FIG. 5, curve 502 is the overall accuracy (with 95% confidence interval bars). Curve 504 shows decision rule sensitivity as a function of threshold value. Curve 506 shows decision rule specificity as a function of threshold value. Using the threshold of 2.07, the overall accuracy for the training samples was estimated to be 73.4% with 95% a confidence interval of 61.4% to 82.8%. The estimated sensitivity was 79.3% and the estimated specificity was 68.6%.

TABLE 8

Confusion matrix for training samples using cross-validated PAM algorithm		
Predicted	True Diagnosis	
	Sepsis	SIRS
Sepsis	23	11
SIRS	6	24

[0475] For the twenty validation samples held back from training, the overall accuracy was estimated to be 70% with a

95% confidence interval of 45.7% to 88.1%, sensitivity 66.7% and specificity 72.7%. Table 9 shows the confusion matrix for the validation samples.

TABLE 9

Confusion matrix for training samples using cross-validated PAM algorithm

Predicted	True Diagnosis	
	Sepsis	SIRS
Sepsis	6	3
SIRS	3	8

[0476] FIG. 6 shows the selected biomarkers, ranked by their relative discriminatory power, and their relative importance in the model. FIG. 6 only shows the fifty most important biomarkers found using the PAM analysis. However, 258 important biomarkers were found. The biomarkers in FIG. 6 are labeled based upon the U133 plus 2.0 probeset to which they bind.

[0477] FIG. 7 provides a summary of the CART, PAM, and random forests classification algorithm (decision rule) performance and associated 95% confidence intervals. Fifty distinct biomarkers were selected from across all the algorithms illustrated in FIG. 7. FIG. 8 illustrates the number of times that common biomarkers were selected across the techniques of Wilcoxon (adjusted), CART, PAM, and RF. FIG. 9 illustrates an overall ranking of biomarkers for the T-36 data set. For the selected biomarkers, the x-axis depicts the percentage of times that it was selected. Within the percentage of times that biomarkers were selected, the biomarkers are ranked. The biomarkers in FIG. 7 are labeled based upon the probeset (oligonucleotide identity) to which they bind.

6.4 Static T₋₁₂ Data Analysis

[0478] In another experiment, a T₋₁₂ static analysis was performed. In the T₋₁₂ static analysis, biomarkers features were measured using a specific blood sample, designated the T₋₁₂ blood sample, obtained from each subject in the training population. The identity of this specific blood sample from a given subject in the training population was dependent upon whether the subject was a SIRS subject (did not develop sepsis during the observation period) or a sepsis subject (did develop sepsis during the observation period). In the case of a sepsis subject, the T₋₁₂ sample was defined as the last blood sample taken from the subject before the subject acquired sepsis. Identification of T₋₁₂ samples in the SIRS subjects in the training population was more discretionary than for the sepsis counterpart subjects because there was no significant event in which the SIRS subjects became septic. Because of this, the identity of the T₋₁₂ samples for the sepsis subjects in the training population was used to identify the T₋₁₂ samples in the SIRS subjects in the training population. Specifically, T₋₁₂ time points (blood samples) for SIRS subjects in the training population were identified by “time-matching” a septic subject and a SIRS subject. For example, consider the case in which a subject that entered the study became clinically-defined as septic on their sixth day of enrollment. For this subject, T₋₁₂ was day five of the study (1-24 hours prior to sepsis), and the T₋₁₂ blood sample was the blood sample that was obtained on day five of the study. Likewise, T₋₁₂ for the SIRS subject that was matched to this sepsis subject was

deemed to be day five of study on this paired SIRS subject. While time matching between arbitrary pairs of SIRS and sepsis subjects was done to identify T₋₁₂ blood samples for as many of the SIRS subjects in the training population as possible, in some instances, T₋₁₂ samples from SIRS subjects had to be selected from the time points based on sample availability.

[0479] For the T₋₁₂ static analysis, there were 54,613 biomarkers measured on 90 samples for a total of 90 corresponding microarray experiments from 90 different subjects. Each sample was collected from a different member the population. Of the 54,613 probesets in each microarray experiment, 31,047 were transformed by log transformations. Further, of the 54,613 probesets in each microarray experiment, 2518 were transformed by a square root transformation. The remaining 21,048 probesets in each microarray experiment were not transformed.

[0480] The 90 member population was initially split into a training set (n=69) and a validation set (n=21). The training set was used to estimate the appropriate classification algorithm parameters while the trained algorithm was applied to the validation set to independently assess performance. Of the 69 training samples, 34 were labeled Sepsis, meaning that the subjects developed sepsis at some point during the observation time period, and 35 were SIRS, meaning that they did not develop sepsis during the observation time period. Table 10 provides distributions of the race, gender and age for these samples.

TABLE 10

Distributions of the race, gender, and age for the training data

Group	Gender	Black	Caucasian	Other
Sepsis	Male	9	13	1
	Female	0	10	1
SIRS	Male	5	20	0
	Female	0	10	0

Group	Minimum	Mean	Median	Maximum
Sepsis	18	42.1	39	80
SIRS	18	44.1	40	90

[0481] For the 21 validation samples, 11 were labeled Sepsis and 10 were labeled SIRS. Table 11 provides distributions of the race, gender and age for these samples.

TABLE 11

Distributions of the race, gender, and age for the validation data

Group	Gender	Black	Caucasian	Other
Sepsis	Male	0	7	0
	Female	0	3	0
SIRS	Male	2	6	0
	Female	0	3	0

Group	Minimum	Mean	Median	Maximum
Sepsis	18	43.3	40	81
SIRS	19	53	52	85

[0482] Each sample in the training data was randomly assigned to one of ten groups used for cross-validation. The number of training samples in these groups ranged from 6 to 8. The samples were assigned in way that attempted to bal-

ance the number of sepsis and SIRS samples across folds. As described in more detail below, several different methods were used to judge whether select biomarkers discriminate between the Sepsis and SIRS groups.

[0483] Wilcoxon and Q-value tests. The first method used to identify discriminating biomarkers was a Wilcoxon test (unadjusted). The abundance value for a given biomarker across the samples in the training data was subjected to the Wilcoxon test. The Wilcoxon test considers both group classification (sepsis versus SIRS) and abundance value in order to compute a p value for the given biomarker. The p value provides an indication of how well the abundance value for the given biomarker across the samples collected in the training set discriminates between the sepsis and SIRS state. The lower the p value, the better the discrimination. When the p value is less than a specific confidence level, such as 0.05, an inference is made that the biomarker discriminates between the sepsis and SIRS phenotype. There were 19,791 significant biomarkers using this method (see Table 12).

[0484] The second method used to identify discriminating biomarkers was the Wilcoxon Test (adjusted). Due to the large number of biomarkers, 54613, and the relatively small number of samples, 90, there was a high risk of finding falsely significant biomarkers. An adjusted p-value was used to counter this risk. In particular, the method of Benjamini and Hochberg, 1995, J.R. Statist. Soc. B 57, pp 289-300, which is hereby incorporated by reference in its entirety, was used to control the false discovery rate. Here, the false discovery rate is defined as the number of biomarkers truly significant divided by the number of biomarkers declared significant. For example, if the adjusted p-value is less than 0.05, there is a 5% chance that the biomarker is a false discovery. Results using this test are reported in Table 12. There were 11851 significant biomarkers using this method (see Table 12). As used, herein, a biomarker is considered significant if it has a p-value of less than 0.05 as determined by the Wilcoxon test (adjusted).

[0485] The third method used to identify discriminating biomarkers was the use of Q values. In such an approach, the biomarkers are ordered by their q-values and if a respective biomarker has a q-value of X, then respective biomarker and all others more significant have a combined false discovery rate of X. However, the false discovery rate for any one biomarker may be much larger. There were 11851 significant biomarkers using this method (see Table 12).

[0486] CART. In addition to analyzing the microarray data using Wilcoxon test and Q-value tests in order to identify biomarkers that discriminate between the sepsis and SIRS subpopulations in the training set, classification and regression tree (CART) analysis was used. CART is described in Section 5.5.1, above. Specifically, the data summarized above was used to predict the disease state by iteratively partitioning the data based on the best single-variable split of the data. In other words, at each stage of the tree building process, the biomarker whose expression values across the training population best discriminate between the sepsis and SIRS population was invoked as a decision branch. Cross-validation was carried out, with the optimal number of splits estimated independently in each of the 10 iterations. The final tree is depicted in FIG. 10. In FIG. 10, decision 1002 makes a decision based on the abundance of the biomarker that binds to probeset X214681_at. If biomarker X214681_at has an abundance that is greater than 7.862 units in a biological sample from a subject to be diagnosed (test biological sample), then control passes to decision 1004. If, on the other hand, if the biomarker that binds to probeset (U133 plus 2.0 oligonucleotide) X214681_at has an abundance that is less than 7.862 units in the test biological sample, decision control passes to decision 1006. Decisions are made in this manner until a terminal leaf of the decision tree is reached, at which point diagnoses of sepsis or SIRS is made. The decision tree in FIG. 10 makes use of the biomarkers that bind to the following four probesets: X214681_at, X1560432_at, X230281_at, and X1007_s_at.

[0487] FIG. 11 shows the distribution of the four biomarkers used in the decision tree between the sepsis and SIRS groups in the training data set. In FIG. 11, the top of each box denotes the 75th percentile of the data across the training set and the bottom of each box denotes the 25th percentile, and the median value for each biomarker across the training set is drawn as a line within each box. The biomarkers are labeled in FIG. 11 based on the identity of the U133 plus 2.0 probes to which they bind). The confusion matrix for the training data where the predicted classifications were made from the cross-validated model is given in Table 13. From this confusion matrix, the overall accuracy was estimated to be 65.2% with a 95% confidence interval of 52.8% to 76.3%. The estimated sensitivity was 61.8% and the estimated specificity was 68.6%.

TABLE 12

Cumulative number of significant calls for the three methods.							
	$\leq 1e-04$	≤ 0.001	≤ 0.01	≤ 0.025	≤ 0.05	≤ 0.1	≤ 1
p-value (unadjusted)	0	5417	11537	15769	19791	24809	54613
p-value (adjusted)	0	0	5043	8374	11851	16973	54613
q-value	0	0	7734	12478	17820	24890	54613

Note that all 90 samples (training and validation) were used to compare Sepsis and SIRS groups. Missing biomarker feature values were not included in the analyses.

TABLE 13

Confusion matrix for training samples using the cross-validated CART algorithm of FIG. 10		
Predicted	True Diagnosis	
	Sepsis	SIRS
Sepsis	21	11
SIRS	13	24

[0488] For the 21 validation samples held back from training data set, the overall accuracy was estimated to be 71.4% with a 95% confidence interval of 47.8% to 88.7%, sensitivity 90.9% and specificity 50%. Table 14 shows the confusion matrix for the validation samples.

TABLE 14

Confusion matrix for validation samples using the cross-validated CART algorithm of FIG. 10		
Predicted	True Diagnosis	
	Sepsis	SIRS
Sepsis	10	5
SIRS	1	5

[0489] Random Forests. Another decision rule that can be developed using biomarkers of the present invention is a Random Forests decision tree. Random Forests is a tree based method that uses bootstrapping instead of cross-validation. For each iteration, a random sample (with replacement) is drawn and the largest tree possible is grown. Each tree receives a vote in the final class prediction. To fit a random forest, the number of trees (e.g. bootstrap iterations) is specified. No more than 500 were used in this example, but at least 50 are needed for a burn-in period. The number of trees was chosen based on the accuracy of the training data. For this data, 439 trees were used to train the algorithm (see FIG. 12). In FIG. 12, curve 1202 is a smoothed estimate of overall accuracy as a function of tree number. Curve 1204 is a smoothed curve of tree sensitivity as a function of tree number. Curve 1206 is a smoothed curve of tree specificity as a function of tree number. Using this algorithm, 845 biomarkers had non-zero importance and were used in the model. The random forest algorithm gauges biomarker importance by the average reduction in the training accuracy. The biomarkers were ranked by this method and are shown in FIG. 13. The figure only reflects the 50 most important biomarkers found by using Random Forest analysis. However, 845 biomarkers were actually found to have discriminating significance. The random forest method uses a number of different decision trees. A biomarker is considered to have discriminating significance if it served as a decision branch of a decision tree from a significant random forest analysis. As used herein, a significant random forest analysis is one where the lower 95% confidence interval on accuracy by cross validation on a training data set is greater than 50% and the point estimate for accuracy on a validation set is greater than 65%.

[0490] The predicted confusion matrix for the training dataset using the decision tree developed using the Random Forest method is given in Table 15. From this confusion matrix, the overall accuracy was estimated to be 75.4% (con-

fidence intervals cannot be computed when using the bootstrap accuracy estimate). The estimated sensitivity was 73.5% and the estimated specificity was 77.1%.

TABLE 15

Confusion matrix for training samples against the decision tree developed using the Random Forest method.		
Predicted	True Diagnosis	
	Sepsis	SIRS
Sepsis	27	9
SIRS	8	25

[0491] For the 21 validation samples held back from training, the overall accuracy was estimated to be 95.2% with a 95% confidence interval of 76.2% to 99.9%, sensitivity 100% and specificity 90%. Table 16 shows the confusion matrix for the validation samples.

TABLE 16

Confusion matrix for the 20 validation samples against the decision tree developed using the Random Forest method.		
Predicted	True Diagnosis	
	Sepsis	SIRS
Sepsis	11	1
SIRS	0	9

[0492] MART. Multiple Additive Regression Trees (MART), also known as “gradient boosting machines,” was used to simultaneously assess the importance of biomarkers and classify the subject samples. Several fitting parameters are specified in this approach including (i) number of trees, (ii) step size (commonly referred to as “shrinkage”), and (iii) degree of interaction (related to the number of splits for each tree). More information on MART is described in Section 5.5.4 above. The degree of interaction was set to 1 to enforce an additive model (e.g. each tree has one split and only uses one biomarker).

[0493] Estimating interactions may require more data to function well. The step size was set to 0.05 so that the model complexity was dictated by the number of trees. The optimal number of trees was estimated by leaving out a random subset of cases at each fitting iteration, then assessing quality of prediction on that subset. After fitting more trees than were warranted, the point at which prediction performance stopped improving was estimated as the optimal point.

[0494] The estimated model used 28 trees and 17 biomarkers across all trees. The MART algorithm also provides a calculation of biomarker importance (summing to 100%), which are given in FIG. 14. Biomarkers with zero importance were excluded. In FIG. 14, biomarkers are labeled by the U133 plus 2.0 oligonucleotide to which they bind. FIG. 15 shows the distribution of the selected biomarkers between the Sepsis and SIRS groups. In FIG. 15, biomarkers are labeled by the U133 plus 2.0 oligonucleotide to which they bind.

[0495] Cross-validation was carried out, with the optimal number of trees estimated independently in each of the 10 iterations. The confusion matrix for the training data where the predicted classifications were made from the cross-validated model is given in Table 17. From this confusion matrix,

the overall accuracy was estimated to be 76.8% with a 95% confidence interval of 65.1% to 86.1%. The estimated sensitivity was 76.5% and the estimated specificity was 77.1%.

TABLE 17

Confusion matrix for the training samples using the cross-validated MART algorithm.		
Predicted	True Diagnosis	
	Sepsis	SIRS
Sepsis	26	8
SIRS	8	27

[0496] For the 21 validation samples held back from training, the overall accuracy was estimated to be 85.7% with a 95% confidence interval of 63.7% to 97%, sensitivity 80% and specificity 90.9%. Table 18 shows the confusion matrix for the validation samples.

TABLE 18

Confusion matrix for the validation samples using the MART algorithm.		
Predicted	True Diagnosis	
	Sepsis	SIRS
Sepsis	8	1
SIRS	2	10

[0497] PAM Yet another decision rule developed using biomarkers of the present invention is predictive analysis of microarrays (PAM), which is described in Section 5.5.2, above. In this method, a shrinkage parameter that determines the number of biomarkers used to classify samples is specified. This parameter was chosen via cross-validation. There were no biomarkers with missing values. Based on cross-validation, the optimal threshold value was 2.1, corresponding to 820 biomarkers. FIG. 16 shows the accuracy across different thresholds. In FIG. 16, curve 1602 is the overall accuracy (with 95% confidence interval bars). Curve 1604 shows decision rule sensitivity as a function of threshold value. Curve 1606 shows decision rule specificity as a function of threshold value. Using the threshold of 2.1, the overall accuracy for the training samples was estimated to be 80.9% with a 95% confidence interval of 73.4% to 86.7%. The estimated sensitivity was 85.7% and the estimated specificity was 76.5%. Table 19 shows the confusion matrix for the training data where the predicted classifications were made from the cross-validated models.

TABLE 19

Confusion matrix for training samples using cross-validated PAM algorithm		
Predicted	True Diagnosis	
	Sepsis	SIRS
Sepsis	30	8
SIRS	5	26

[0498] For the 21 validation samples held back from training, the overall accuracy was estimated to be 95.2% with a

95% confidence interval of 76.2% to 99.9%, sensitivity 100% and specificity 90%. Table 20 shows the confusion matrix for the validation samples.

TABLE 20

Confusion matrix for validation samples using cross-validated PAM algorithm		
Predicted	True Diagnosis	
	Sepsis	SIRS
Sepsis	11	1
SIRS	0	9

[0499] FIG. 17 shows the selected biomarkers, ranked by their relative discriminatory power, and their relative importance in the model. FIG. 17 only shows the fifty most important biomarkers found using the PAM analysis. However, 820 important biomarkers were found. In FIG. 17, biomarkers are labeled by the U133 plus 2.0 oligonucleotide to which they bind.

[0500] FIG. 18 provides a summary of the CART, MART, PAM, and random forests (RF) classification algorithm (decision rule) performance and associated 95% confidence intervals. Fifty distinct biomarkers were selected from across all the algorithms illustrated in FIG. 18. The identity of these fifty selected features is shown in FIG. 20.

[0501] FIG. 19 illustrates the number of times that common biomarkers were selected across the techniques of CART, MART, PAM, RF, and Wilcoxon (adjusted). FIG. 20 illustrates an overall ranking of biomarkers for the T_{-12} data set. For the selected biomarkers, the x-axis depicts the percentage of times that it was selected. Within the percentage of times that biomarkers were selected, the biomarkers are ranked. In FIG. 20, biomarkers are labeled by the U133 plus 2.0 oligonucleotide to which they bind.

6.5 Baseline T_{-12} Data Analysis

[0502] In another example, a baseline T_{-12} analysis was performed. Feature values for biomarkers in this example were computed as the differential between two time points.

[0503] The two time points for each respective subject in a training population were (i) the T_{-12} time point and (ii) the first measurement, T_{first} , taken of the respective subject. It will be appreciated that T_{first} could differ across the training population. For example, in some subjects, T_{first} was two days before T_{-12} , in some subjects T_{first} was three days before T_{-12} , and so forth. To illustrate the computation of a feature value in accordance with the T_{-12} baseline analysis, consider the case in which biomarker A was evaluated. To compute a feature value for biomarker A for the purposes of the baseline T_{-12} analysis, the abundance of biomarker A in the T_{-12} blood sample for a respective subject in the training population $[A]_{T_{-12}}$, was obtained. Further, the abundance of biomarker A from the first blood sample taken for the respective subject, $[A]_{first}$, was obtained. The feature value for A for this respective subject was then computed as $\Delta A = [A]_{T_{-12}} - [A]_{first}$. This calculation was repeated for each subject in the training population and for each biomarker under consideration.

[0504] For the baseline T_{-12} analysis, there were 54,613 probesets measured on 89 samples for a total of 89 corresponding microarray experiments from 89 different subjects. Each sample was collected from a different member of the

population. Of the 54,613 probesets in each microarray experiment, 31,047 were transformed by log transformations. Further, of the 54,613 probesets in each microarray experiment, 2518 were transformed by a square root transformation. The remaining 21,048 probesets in each microarray experiment were not transformed.

[0505] The 89 member population was initially split into a training set (n=68) and a validation set (n=21). The training set was used to estimate the appropriate classification algorithm parameters while the trained algorithm was applied to the validation set to independently assess performance. Of the 68 training samples, 33 were Sepsis, meaning that the subjects developed sepsis at some point during the observation time period, and 35 were SIRS, meaning that they did not develop sepsis during the observation time period. Table 21 provides distributions of the race, gender and age for these samples.

TABLE 21

Distributions of the race, gender, and age for the training data				
Group	Gender	Black	Caucasian	Other
Sepsis	Male	9	12	1
	Female	0	10	1
SIRS	Male	5	20	0
	Female	0	10	0
Group	Minimum	Mean	Median	Maximum
Sepsis	18	42.7	39	80
SIRS	18	44.1	40	90

[0506] For the 21 validation samples, 11 were Sepsis and 10 were SIRS. Table 22 provides distributions of the race, gender and age for these samples.

TABLE 22

Distributions of the race, gender, and age for the validation data				
Group	Gender	Black	Caucasian	Other
Sepsis	Male	0	7	0
	Female	0	3	0
SIRS	Male	2	6	0
	Female	0	3	0
Group	Minimum	Mean	Median	Maximum
Sepsis	18	43.3	40	81
SIRS	19	53	52	85

[0507] Each sample in the training data was randomly assigned to one of ten groups used for cross-validation. The

number of training samples in these groups ranged from 6 to 8. The samples were assigned in way that attempted to balance the number of sepsis and SIRS samples across folds. As described in more detail below, several different methods were used to judge whether select biomarkers discriminate between the Sepsis and SIRS groups.

[0508] Wilcoxon and Q-value tests. The first method used to identify discriminating biomarkers was a Wilcoxon test (unadjusted). The abundance value for a given biomarker from all samples in the training data was subjected to the Wilcoxon test. The Wilcoxon test considers both group classification (sepsis versus SIRS) and abundance value in order to compute a p value for the given biomarker. The p value provides an indication of how well the abundance value for the given biomarker across the samples collected in the training set discriminates between the sepsis and SIRS state. The lower the p value, the better the discrimination. When the p value is less than a specific confidence level, such as 0.05, an inference is made that the biomarker discriminates between the sepsis and SIRS phenotype. There were 6427 significant biomarkers using this method (see Table 23).

[0509] The second method used to identify discriminating biomarkers was the Wilcoxon Test (adjusted). Due to the large number of biomarkers, 54613, and the relatively small number of samples, 89, there was a high risk of finding falsely significant biomarkers. An adjusted p-value was used to counter this risk. In particular, the method of Benjamini and Hochberg, 1995, J.R. Statist. Soc. B 57, pp 289-300, which is hereby incorporated by reference in its entirety, was used to control the false discovery rate. Here, the false discovery rate is defined as the number of biomarkers truly significant divided by the number of biomarkers declared significant. For example, if the adjusted p-value is less than 0.05, there is a 5% chance that the biomarker is a false discovery. Results using this test are reported in Table 12. There were 482 significant biomarkers using this method (see Table 23). As used, herein, a biomarker is considered significant if it has a p-value of less than 0.05 as determined by the Wilcoxon test (adjusted).

[0510] The third method used to identify discriminating biomarkers was the use of Q values. The biomarkers are ordered by their q-values and if a biomarker has a q-value of X, then this biomarker and all others more biomarkers have a combined false discovery rate of X. However, the false discovery rate for any one biomarker may be much larger. There were 482 significant biomarkers using this method (see Table 23).

TABLE 23

	Cumulative number of significant calls for the three methods.						
	≤1e-04	≤0.001	≤0.01	≤0.025	≤0.05	≤0.1	≤1
p-value (unadjusted)	0	808	2486	4230	6427	10051	54613
p-value (adjusted)	0	0	0	0	482	1035	54613
q-value	0	0	0	0	606	1283	54613

Note that all 89 samples (training and validation) were used to compare Sepsis and SIRS groups. Missing biomarker values were not included in the analyses.

[0511] CART. In addition to analyzing the microarray data using Wilcoxon test and Q-value tests in order to identify biomarkers that discriminate between the sepsis and SIRS subpopulations in the training set, classification and regression tree (CART) analysis was used. CART is described in Section 5.5.1, above. Specifically, the data summarized above was used to predict the disease state by iteratively partitioning the data based on the best single-variable (biomarker) split of the data. In other words, at each stage of the tree building process, the biomarker whose abundance value across the training population best discriminates between the sepsis and SIRS population was invoked as a decision branch. Cross-validation was carried out, with the optimal number of splits estimated independently in each of the 10 iterations. The final tree is depicted in FIG. 21. In FIG. 21, decision 2102 makes a decision based on the abundance of the biomarker that bind to U133 plus 2.0 probe X210119_at. If this biomarker that binds to X210119_at has an abundance that is less than -0.03669 units in a biological sample from a subject to be diagnosed (test biological sample), then control passes to decision 2104. If, on the other hand, the biomarker that binds to probeset X210119_at has an abundance that is greater than -0.03669 units in the test biological sample, decision control passes to decision 2106. Decisions are made in this manner until a terminal leaf of the decision tree is reached, at which point diagnoses of sepsis or SIRS is made. The decision tree in FIG. 21 makes use of the biomarkers that bind to the following five U133 plus 2.0 oligonucleotides: X210119_at, X1552554_a_at, X1554390_s_at, X1552301_a_at, and X1555868_at.

[0512] FIG. 22 shows the distribution of the five biomarkers used in the decision tree between the sepsis and SIRS groups in the training data set. In FIG. 22, the top of each box denotes the 75th percentile of the data across the training set and the bottom of each box denotes the 25th percentile, and the median value for each biomarker across the training set is drawn as a line within each box. In FIG. 22, biomarkers are labeled by the U133 plus 2.0 oligonucleotides to which they bind. The confusion matrix for the training data where the predicted classifications were made from the cross-validated model is given in Table 24. From this confusion matrix, the overall accuracy was estimated to be 80.9% with a 95% confidence interval of 69.5% to 89.4%. The estimated sensitivity was 93.9% and the estimated specificity was 68.6%.

TABLE 24

Confusion matrix for training samples using the cross-validated CART algorithm of FIG. 21.		
Predicted	True Diagnosis	
	Sepsis	SIRS
Sepsis	31	11
SIRS	2	24

[0513] For the 21 validation samples held back from training data set, the overall accuracy was estimated to be 71.4% with a 95% confidence interval of 47.8% to 88.7%, sensitivity 72.7% and specificity 70%. Table 25 shows the confusion matrix for the validation samples.

TABLE 25

Confusion matrix for validation samples using the cross-validated CART algorithm of FIG. 21.		
Predicted	True Diagnosis	
	Sepsis	SIRS
Sepsis	10	5
SIRS	1	5

[0514] Random Forests. Another decision rule that can be developed using biomarkers is a Random Forests decision tree. To fit a random forest, the number of trees (e.g. bootstrap iterations) is specified. No more than 500 were used in this example, but at least 50 are needed for a burn-in period. The number of trees was chosen based on the accuracy of the training data. For this data, 482 trees were used to train the algorithm (see FIG. 23). In FIG. 23, curve 2302 is a smoothed estimate of overall accuracy as a function of tree number. Curve 2304 is a smoothed curve of tree sensitivity as a function of tree number. Curve 2306 is a smoothed curve of tree specificity as a function of tree number. Using this algorithm, 482 biomarkers had non-zero importance and were used in the model. The random forest algorithm gauges biomarker importance by the average reduction in the training accuracy. The biomarkers were ranked by this method and are shown in FIG. 24. The figure only reflects the 50 most important biomarkers found by using Random Forest analysis. However, 893 biomarkers were actually found to have discriminating significance. The random forest method uses a number of different decision trees. A biomarker is considered to have discriminating significance if it served as a decision branch of a decision tree from a significant random forest analysis. As used herein, a significant random forest analysis is one where the lower 95% confidence interval on accuracy by cross validation on a training data set is greater than 50% and the point estimate for accuracy on a validation set is greater than 65%.

[0515] The predicted confusion matrix for the training dataset using the decision tree developed using the Random Forest method is given in Table 26. From this confusion matrix, the overall accuracy was estimated to be 61.8% (confidence intervals cannot be computed when using the bootstrap accuracy estimate). The estimated sensitivity was 57.6% and the estimated specificity was 65.7%.

TABLE 26

Confusion matrix for training samples against the decision tree developed using the Random Forest method.		
Predicted	True Diagnosis	
	Sepsis	SIRS
Sepsis	23	14
SIRS	12	19

[0516] For the 21 validation samples held back from training, the overall accuracy was estimated to be 72.6% with a 95% confidence interval of 52.8% to 91.8%, sensitivity 63.9% and specificity 90%. Table 27 shows the confusion matrix for the validation samples.

TABLE 27

Confusion matrix for the 20 validation samples against the decision tree developed using the Random Forest method.		
Predicted	True Diagnosis	
	Sepsis	SIRS
Sepsis	7	1
SIRS	4	9

[0517] PAM Yet another decision rule developed using biomarkers is predictive analysis of microarrays (PAM), which is described in Section 5.5.2, above. In this method, a shrinkage parameter that determines the number of biomarkers used to classify samples is specified. This parameter was chosen via cross-validation. There were no biomarkers with missing values. Based on cross-validation, the optimal threshold value was 1.62, corresponding to 269 biomarkers. FIG. 25 shows the accuracy across different thresholds. In FIG. 25, curve 2502 is the overall accuracy (with 95% confidence interval bars). Curve 2504 shows decision rule sensitivity as a function of threshold value. Curve 2506 shows decision rule specificity as a function of threshold value. Using the threshold of 1.62, the overall accuracy for the training samples was estimated to be 67.7% with a 95% confidence interval of 55.9% to 77.6%. The estimated sensitivity was 68.6% and the estimated specificity was 66.7%. Table 28 shows the confusion matrix for the training data where the predicted classifications were made from the cross-validated models.

TABLE 28

Confusion matrix for training samples using cross-validated PAM algorithm		
Predicted	True Diagnosis	
	Sepsis	SIRS
Sepsis	24	11
SIRS	11	22

[0518] For the 21 validation samples held back from training, the overall accuracy was estimated to be 81% with a 95% confidence interval of 58.1% to 94.6%, sensitivity 72.7% and specificity 100%. Table 26 shows the confusion matrix for the validation samples.

TABLE 29

Confusion matrix for validation samples using cross-validated PAM algorithm		
Predicted	True Diagnosis	
	Sepsis	SIRS
Sepsis	8	1
SIRS	3	9

[0519] FIG. 26 shows the selected biomarkers, ranked by their relative discriminatory power, and their relative importance in the model. FIG. 26 only shows the fifty most important biomarkers found using the PAM analysis. However, 269

biomarker were found. In FIG. 26, biomarkers are labeled by the U133 plus 2.0 oligonucleotides to which they bind.

[0520] FIG. 27 provides a summary of the CART, PAM and random forests classification algorithm (decision rule) performance and associated 95% confidence intervals. Fifty distinct biomarkers were selected from across all the algorithms illustrated in FIG. 27. FIG. 28 illustrates the number of times that common biomarkers were selected across the techniques of CART, PAM, RF, and Wilcoxon (adjusted). In FIG. 28, biomarkers are labeled by the U133 plus 2.0 oligonucleotide to which they bind. FIG. 29 illustrates an overall ranking of biomarkers for the T_0 base data set. In FIG. 29, biomarkers are labeled by the U133 plus 2.0 oligonucleotide to which they bind. For the selected biomarkers, the x-axis depicts the percentage of times that it was selected. Within the percentage of times that biomarkers were selected, the biomarkers are ranked.

6.6 Select Biomarkers

[0521] Sections 6.3 through 6.5 describe experiments in which blood samples from SIRS positive subjects have been tested using Affymetrix U133 plus 2.0 human genome chips containing 54,613 probesets. This section describes the criteria applied to the data described in Sections 6.3 through 6.5 in order to identify a list of biomarkers that discriminate between subjects likely to develop sepsis in a defined time period (sepsis subjects) and subjects not likely to develop sepsis in a defined time period (SIRS subjects). FIG. 30 illustrates the filters applied to identify this list of biomarkers.

[0522] A first criterion that was imposed was a requirement that a biomarker discriminate between SIRS and sepsis with a p value of 0.05 or less, as determined by the Wilcoxon test after correction for multiple comparisons, at any time point measured or the biomarker was used in a multivariate analysis with significant classification performance where significant classification performance is defined by having a lower 95th percentile for accuracy on a training data set that is greater than 50% and a point estimate for accuracy on the validation set greater than 65% at any time point measured. At T_{-36} (Section 6.3), 1,618 biomarkers met this criterion. At T_{-12} (Section 6.4), 12,728 biomarkers met this criterion. Some biomarkers met this criterion at both T_{-12} and T_{-36} time points. In total, there were 14,346 biomarkers (including duplicates from T_{-12} and T_{-36} time points) that discriminated between the sepsis and SIRS states. Thus, the first filter criterion reduced the number of eligible biomarkers from 54,613 to 14,346.

[0523] The second criterion that was imposed was a requirement that each respective biomarker under consideration exhibit at least a 1.2 \times fold change between the median value for the respective biomarker among the subjects that acquired sepsis during a defined time period (sepsis subjects) and the median value for the respective biomarker among subjects that do not acquire sepsis during the defined time period (SIRS subjects) at the T_{-36} time or the T_{-12} time point period. Furthermore, to satisfy the second criterion, the biomarker must have been used in at least one multivariate analysis with significant classification performance where significant classification performance is defined by having a lower 95th percentile for accuracy on a training data set that is greater than 50% and a point estimate for accuracy on the validation set that is greater than 65% at any time point measured. As

noted in FIG. 30, application of the third filter criterion reduced the number of eligible biomarkers from 14,346 to 626.

[0524] In column one of Table 30, each biomarker is listed by a gene name, such as, for example, a Human Gene Nomenclature Database (HUGO) symbol set forth by the Gene Nomenclature Committee, Department of Biology, University College London. As is known in the art, some human genome genes are represented by more than one probeset in the U133 plus 2.0 array. Furthermore, some of the oligonucleotides in the U133 plus 2.0 array represent expressed sequence tags (ESTs) that do not correspond to a known gene (see column two of Table 30). Where known, the names of the different human genes are listed in column three of Table 30.

[0525] In the case where a biomarker is based upon a gene that includes the sequence of a probeset listed in Table 30 or a complement thereof, the biomarker can be, for example, a transcript made by the gene, a complement thereof, or a discriminating fragment or complement thereof, or a cDNA thereof, or a discriminating fragment of the cDNA, or a discriminating amplified nucleic acid molecule corresponding to all or a portion of the transcript or its complement, or a protein encoded by the gene, or a discriminating fragment of the protein, or an indication of any of the above. Further still, the biomarker can be, for example, a protein encoded by a

gene that includes a probeset sequence described in Table 30 or a discriminating fragment of the protein, or an indication of the above. Here, a discriminating molecule or fragment is a molecule or fragment that, when detected, indicates presence or abundance of the above-identified transcript, cDNA, amplified nucleic acid, or protein. In one embodiment, a biomarker profile of the present invention comprises a plurality of biomarkers that contain at least five, at least ten at least fifteen, at least twenty, at least thirty, between 2 and 5, between 3 and 7, or less than 15 of the sequences of the probesets of Table 30, or complements thereof, or genes including one of at least five of the sequences or complements thereof, or a discriminating fragment thereof, or an amino acid sequence encoded by any of the foregoing nucleic acid sequences, or any discriminating fragment of such an amino acid sequence. Such biomarkers can be mRNA transcripts, cDNA or some other form of amplified nucleic acid or proteins. In some embodiments a biomarker is any gene that includes the sequence in an Affymetrix probeset given in Table 30, or any gene that includes a complement of the sequence in an Affymetrix probeset given in Table 30, or any mRNA, cDNA or other form of amplified nucleic acid of the foregoing, for any discriminating fragment of the foregoing, or any amino acid sequence coded by the foregoing, or any discriminating fragment of such a protein.

TABLE 30

Exemplary biomarkers that discriminate between responders and nonresponders				
Gene Symbol Column 1	Affymetrix Probeset name Column 2	Gene Name Column 3	Gene Accession Number Column 4	Protein Accession Number Column 5
FLJ20445	218582_at	HYPOTHETICAL PROTEIN FLJ20445	NM_017824	
3'HEXO	231852_at	HISTONE MRNA 3' END EXORIBONUCLEASE	NM_153332	NP_699163
3'HEXO	226416_at	HISTONE MRNA 3' END EXORIBONUCLEASE	NM_153332	NP_699163
ABCA2	212772_s_at	ATP-BINDING CASSETTE, SUB-FAMILY A (ABC1), MEMBER 2	NM_001606 NM_212533	NP_001597 NP_997698
ABHD2	228490_at	ABHYDROLASE DOMAIN CONTAINING 2	NM_007011 NM_152924	NP_008942 NP_690888
ACN9	218981_at	ACN9 HOMOLOG (<i>S. CEREVISIAE</i>)	NM_020186	NP_064571
ACSL1	201963_at	ACYL-COA SYNTHETASE LONG-CHAIN FAMILY MEMBER 1	NM_001995	NP_001986
ACSL3	201660_at	ACYL-COA SYNTHETASE LONG-CHAIN FAMILY MEMBER 3	NM_004457NM_203372	NP_004448 NP_976251
ACSL4	202422_s_at	ACYL-COA SYNTHETASE LONG-CHAIN FAMILY MEMBER 4	NM_004458 NM_022977	NP_004449 NP_075266
ACTR3	213101_s_at	ARP3 ACTIN-RELATED PROTEIN 3 HOMOLOG (YEAST)	NM_005721	NP_005712
ADM	202912_at	ADRENOMEDULLIN	NM_001124	NP_001115
ADORA2A	205013_s_at	ADENOSINE A2 RECEPTOR	NM_000675	NP_000666
AIM2	206513_at	ABSENT IN MELANOMA 2	NM_004833	NP_004824
ALOX5AP	204174_at	ARACHIDONATE 5- LIPOXYGENASE- ACTIVATING PROTEIN	NM_001629	NP_001620
AMPD2	212360_at	ADENOSINE MONOPHOSPHATE DEAMINASE 2 (ISOFORM L)	NM_004037 NM_139156 NM_203404	NP_004028 NP_631895 NP_981949

TABLE 30-continued

Exemplary biomarkers that discriminate between responders and nonresponders				
Gene Symbol Column 1	Affymetrix Probeset name Column 2	Gene Name Column 3	Gene Accession Number Column 4	Protein Accession Number Column 5
ANKRD22	238439_at	ANKYRIN REPEAT DOMAIN 22	NM_144590	NP_653191
ANKRD22	239196_at	ANKYRIN REPEAT DOMAIN 22	NM_144590	NP_653191
ANXA3	209369_at	ANNEXIN A3	NM_005139	NP_005130
APG3L	220237_at	APG3 AUTOPHAGY 3-LIKE (<i>S. CEREVISIAE</i>)	NM_022488	NP_071933
ARHGAP8	47069_at	RHO GTPASE ACTIVATING PROTEIN 8	NM_015366 NM_017701 NM_181333 NM_181334 NM_181335 XM_084482	NP_056181 NP_060171 NP_851850 NP_851851 NP_851852 XP_084482
ARID5B	212614_at	AT RICH INTERACTIVE DOMAIN 5B (MRF1-LIKE)	XM_084482	XP_084482
ASAH1	214765_s_at	N-ACYLSPHINGOSINE AMIDOHYDROLASE-LIKE PROTEIN	NM_014435	NP_055250
ASAH1	232072_at	N-ACYLSPHINGOSINE AMIDOHYDROLASE-LIKE PROTEIN	NM_014435	NP_055250
ASAH1	227135_at	N-ACYLSPHINGOSINE AMIDOHYDROLASE-LIKE PROTEIN	NM_014435	NP_055250
ASPH	242037_at	ASPARTATE BETA- HYDROXYLASE	NM_004318 NM_020164 NM_032466 NM_032467 NM_032468 XM_087254	NP_004309 NP_064549 NP_115855 NP_115856 NP_115857 XP_087254
ATP11B	1554557_at	ATPASE, CLASS VI, TYPE 11B	XM_087254	XP_087254
ATP11B	1564064_a_at	ATPASE, CLASS VI, TYPE 11B	XM_087254	XP_087254
ATP11B	1554556_a_at	ATPASE, CLASS VI, TYPE 11B	XM_087254	XP_087254
ATP11B	212536_at	ATPASE, CLASS VI, TYPE 11B	XM_087254	XP_087254
ATP11B	1564063_a_at	ATPASE, CLASS VI, TYPE 11B	XM_087254	XP_087254
ATP6V1C1	202872_at	ATPASE, H+ TRANSPORTING, LYSOSOMAL, 42-KD, V1 SUBUNIT C, ISOFORM 1	NM_001007254 NM_001695	NP_001007255 NP_001686
ATP6V1C1	202874_s_at	ATPASE, H+ TRANSPORTING, LYSOSOMAL, 42-KD, V1 SUBUNIT C, ISOFORM 1	NM_001007254 NM_001695	NP_001007255 NP_001686
ATP6V1C1	226463_at	ATPASE, H+ TRANSPORTING, LYSOSOMAL, 42-KD, V1 SUBUNIT C, ISOFORM 1	NM_001007254 NM_001695	NP_001007255 NP_001686
ATP9A	212062_at	ATPASE, CLASS II, TYPE 9A	XM_030577	XP_030577
B4GALT5	221485_at	BETA-1,4- GALACTOSYLTRANSFERASE	NM_004776	NP_004767
BASP1	202391_at	BRAIN-ABUNDANT SIGNAL PROTEIN	NM_006317	NP_006308
BAT5	224756_s_at	HLA-B ASSOCIATED TRANSCRIPT 5	NM_021160	NP_066983
BATF	205965_at	BASIC LEUCINE ZIPPER TRANSCRIPTION FACTOR, ATF-LIKE	NM_006399	NP_006390
BAZ1A	217986_s_at	BROMODOMAIN ADJACENT TO ZINC FINGER DOMAIN, 1A	NM_013448 NM_182648	NP_038476 NP_872589
BAZ1A	217985_s_at	BROMODOMAIN ADJACENT TO ZINC FINGER DOMAIN, 1A	NM_013448 NM_182648	NP_038476 NP_872589

TABLE 30-continued

Exemplary biomarkers that discriminate between responders and nonresponders				
Gene Symbol Column 1	Affymetrix Probeset name Column 2	Gene Name Column 3	Gene Accession Number Column 4	Protein Accession Number Column 5
BCL2A1	205681_at	BCL2-RELATED PROTEIN A1	NM_004049	NP_004040
BCL3	204908_s_at	B-CELL CLL/LYMPHOMA 3	NM_005178	NP_005169
BCL3	204907_s_at	B-CELL CLL/LYMPHOMA 3	NM_005178	NP_005169
BCL6	203140_at	B-CELL LYMPHOMA 6	NM_001706	NP_001697
			NM_138931	NP_620309
BCL6	215990_s_at	B-CELL LYMPHOMA 6	NM_001706	NP_001697
			NM_138931	NP_620309
BIK	205780_at	BCL2-INTERACTING KILLER (APOPTOSIS- INDUCING)	NM_001197	NP_001188
BMX	206464_at	BONE MARROW KINASE, X-LINKED	NM_001721	NP_001712
			NM_203281	NP_975010
C13orf12	217769_s_at	CHROMOSOME 13 OPEN READING FRAME 12	NM_015932	NP_057016
C14orf101	225675_at	CHROMOSOME 14 OPEN READING FRAME 101	NM_017799	NP_060269
C14orf101	219757_s_at	CHROMOSOME 14 OPEN READING FRAME 101	NM_017799	NP_060269
C14orf147	213508_at	CHROMOSOME 14 OPEN READING FRAME 147	NM_138288	NP_612145
C16orf30	219315_s_at	CHROMOSOME 16 OPEN READING FRAME 30	NM_024600	NP_078876
C16orf7	205781_at	CHROMOSOME 16 OPEN- READING FRAME 7	NM_004913	NP_004904
C1GALT1	219439_at	CORE 1 SYNTHASE, GLYCOPROTEIN-N- ACETYLGALACTOSAMINE 3-BETA- GALACTOSYLTRANSFERASE	NM_020156	NP_064541
C1GALT1C1	219283_at	C1GALT1-SPECIFIC CHAPERONE 1	NM_001011551	NP_001011551
			NM_152692	NP_689905
C1GALT1C1	238989_at	C1GALT1-SPECIFIC CHAPERONE 1	NM_001011551	NP_001011551
			NM_152692	NP_689905
C1orf8	200620_at	CHROMOSOME 1 OPEN READING FRAME 8	NM_004872	NP_004863
C1RL	218983_at	COMPLEMENT COMPONENT 1, R SUBCOMPONENT-LIKE	NM_016546	NP_057630
C20orf24	217835_x_at	CHROMOSOME 20 OPEN READING FRAME 24	NM_018840	NP_061328
			NM_199483	NP_955777
			NM_199484	NP_955778
			NM_199485	NP_955779
C20orf24	223880_x_at	CHROMOSOME 20 OPEN READING FRAME 24	NM_018840	NP_061328
			NM_199483	NP_955777
			NM_199484	NP_955778
			NM_199485	NP_955779
C20orf32	1554786_at	CHROMOSOME 20 OPEN- READING FRAME 32	NM_020356	NP_065089
C21orf91	220941_s_at	CHROMOSOME 21 OPEN READING FRAME 91	NM_017447	NP_059143
C2orf25	217883_at	CHROMOSOME 2 OPEN READING FRAME 25	NM_015702	NP_056517
C2orf33	223354_x_at	CHROMOSOME 2 OPEN READING FRAME 33	NM_020194	NP_064579
C6orf83	225850_at	CHROMOSOME 6 OPEN READING FRAME 83	NM_145169	NP_660152
C9orf19	225604_s_at	CHROMOSOME 9 OPEN READING FRAME 19	NM_022343	NP_071738
C9orf46	218992_at	CHROMOSOME 9 OPEN READING FRAME 46	NM_018465	NP_060935
C9orf84	1553920_at	CHROMOSOME 9 OPEN READING FRAME 84	NM_173521	NP_775792
CA4	206208_at	CARBONIC ANHYDRASE IV	NM_000717	NP_000708
CA4	206209_s_at	CARBONIC ANHYDRASE IV	NM_000717	NP_000708

TABLE 30-continued

Exemplary biomarkers that discriminate between responders and nonresponders				
Gene Symbol Column 1	Affymetrix Probeset name Column 2	Gene Name Column 3	Gene Accession Number Column 4	Protein Accession Number Column 5
CAB39	217873_at	CALCIUM BINDING PROTEIN 39	NM_016289	NP_057373
CACNA1E	236013_at	CALCIUM CHANNEL, VOLTAGE-DEPENDENT, ALPHA 1E SUBUNIT	NM_000721	NP_000712
CACNA2D3	219714_s_at	CALCIUM CHANNEL, VOLTAGE-DEPENDENT, ALPHA 2/DELTA 3 SUBUNIT	NM_018398	NP_060868
CAPZA2	1569450_at	CAPPING PROTEIN (ACTIN FILAMENT) MUSCLE Z- LINE, ALPHA 2	NM_006136	NP_006127
CARD12	1552553_a_at	CASPASE RECRUITMENT DOMAIN FAMILY, MEMBER 12	NM_021209	NP_067032
CASP4	209310_s_at	CASPASE 4, APOPTOSIS- RELATED CYSTEINE PROTEASE	NM_001225 NM_033306 NM_033307	NP_001216 NP_150649 NP_150650
CCL5	1555759_a_at	CHEMOKINE (C-C MOTIF) LIGAND 5	NM_002985	NP_002976
CCPG1	221511_x_at	CELL CYCLE PROGRESSION 1	NM_004748 NM_020739	NP_004739 NP_065790
CD4	203547_at	CD4 ANTIGEN (P55)	NM_000616	NP_000607
CD48	237759_at	CD48 ANTIGEN (B-CELL MEMBRANE PROTEIN)	NM_001778	NP_001769
CD58	211744_s_at	CD58 ANTIGEN, (LYMPHOCYTE FUNCTION-ASSOCIATED ANTIGEN 3)	NM_001779	NP_001770
CD58	205173_x_at	CD58 ANTIGEN, (LYMPHOCYTE FUNCTION-ASSOCIATED ANTIGEN 3)	NM_001779	NP_001770
CD58	216942_s_at	CD58 ANTIGEN, (LYMPHOCYTE FUNCTION-ASSOCIATED ANTIGEN 3)	NM_001779	NP_001770
CD59	228748_at	CD59 ANTIGEN P18-20 (ANTIGEN IDENTIFIED BY MONOCLONAL ANTIBODIES 16.3A5, EJ16, EJ30, EL32 AND G344)	NM_000611 NM_203329 NM_203330 NM_203331	NP_000602 NP_976074 NP_976075 NP_976076
CD59	200985_s_at	CD59 ANTIGEN P18-20 (ANTIGEN IDENTIFIED BY MONOCLONAL ANTIBODIES 16.3A5, EJ16, EJ30, EL32 AND G344)	NM_000611 NM_203329 NM_203330 NM_203331	NP_000602 NP_976074 NP_976075 NP_976076
CD59	200984_s_at	CD59 ANTIGEN P18-20 (ANTIGEN IDENTIFIED BY MONOCLONAL ANTIBODIES 16.3A5, EJ16, EJ30, EL32 AND G344)	NM_000611 NM_203329 NM_203330 NM_203331	NP_000602 NP_976074 NP_976075 NP_976076
CD59	212463_at	CD59 ANTIGEN P18-20 (ANTIGEN IDENTIFIED BY MONOCLONAL ANTIBODIES 16.3A5, EJ16, EJ30, EL32 AND G344)	NM_000611 NM_203329 NM_203330 NM_203331	NP_000602 NP_976074 NP_976075 NP_976076
CD74	209619_at	CD74 ANTIGEN (INVARIANT POLYPEPTIDE OF MAJOR HISTOCOMPATIBILITY COMPLEX, CLASS II ANTIGEN-ASSOCIATED)	NM_004355	NP_004346
CD74	1567628_at	CD74 ANTIGEN (INVARIANT POLYPEPTIDE OF MAJOR HISTOCOMPATIBILITY	NM_004355	NP_004346

TABLE 30-continued

Exemplary biomarkers that discriminate between responders and nonresponders				
Gene Symbol Column 1	Affymetrix Probeset name Column 2	Gene Name Column 3	Gene Accession Number Column 4	Protein Accession Number Column 5
CD86	210895_s_at	COMPLEX, CLASS II ANTIGEN-ASSOCIATED) CD86 ANTIGEN (CD28 ANTIGEN LIGAND 2, B7-2 ANTIGEN)	NM_006889 NM_175862	NP_008820 NP_787058
CDKN3	209714_s_at	CYCLIN-DEPENDENT KINASE INHIBITOR 3 (CDK2-ASSOCIATED DUAL SPECIFICITY PHOSPHATASE)	NM_005192	NP_005183
CEACAM1	209498_at	CARCINOEMBRYONIC ANTIGEN-RELATED CELL ADHESION MOLECULE 1	NM_001712	NP_001703
CEACAM1	206576_s_at	CARCINOEMBRYONIC ANTIGEN-RELATED CELL ADHESION MOLECULE 1	NM_001712	NP_001703
CEACAM1	211889_x_at	CARCINOEMBRYONIC ANTIGEN-RELATED CELL ADHESION MOLECULE 1	NM_001712	NP_001703
CEACAM1	211883_x_at	CARCINOEMBRYONIC ANTIGEN-RELATED CELL ADHESION MOLECULE 1	NM_001712	NP_001703
CEACAM3	208052_x_at	CARCINOEMBRYONIC ANTIGEN-RELATED CELL ADHESION MOLECULE 3	NM_001815	NP_001806
CECR1	219505_at	CAT EYE SYNDROME CHROMOSOME REGION, CANDIDATE 1	NM_017424 NM_177405	NP_059120 NP_803124
CHCHD7	222701_s_at	COILED-COIL-HELIX DOMAIN-CONTAINING PROTEIN 7	NM_001011667 NM_001011668 NM_001011669 NM_001011670 NM_001011671 NM_024300 NM_014918	NP_001011667 NP_001011668 NP_001011669 NP_001011670 NP_001011671 NP_077276 NP_055733
CHSY1	203044_at	CARBOHYDRATE SYNTHASE 1	NM_004882	NP_004873
CIR	209571_at	CBF1 INTERACTING COREPRESSOR	NM_199075	NP_951057
CKLF	223451_s_at	CHEMOKINE-LIKE FACTOR	NM_016326 NM_016951 NM_181640 NM_181641	NP_057410 NP_058647 NP_857591 NP_857592
CKLF	219161_s_at	CHEMOKINE-LIKE FACTOR	NM_016326 NM_016951 NM_181640 NM_181641	NP_057410 NP_058647 NP_857591 NP_857592
CKLF	221058_s_at	CHEMOKINE-LIKE FACTOR	NM_016326 NM_016951 NM_181640 NM_181641	NP_057410 NP_058647 NP_857591 NP_857592
CKLFSF1	235286_at	CHEMOKINE-LIKE FACTOR SUPER FAMILY 1	NM_052999 NM_181268 NM_181269 NM_181270 NM_181271 NM_181272 NM_181283 NM_181285 NM_181286 NM_181287 NM_181288 NM_181289 NM_181290 NM_181292 NM_181293 NM_181294 NM_181295	NP_443725 NP_851785 NP_851786 NP_851787 NP_851788 NP_851789 NP_851800 NP_851802 NP_851803 NP_851804 NP_851805 NP_851806 NP_851807 NP_851809 NP_851810 NP_851811 NP_851812

TABLE 30-continued

Exemplary biomarkers that discriminate between responders and nonresponders				
Gene Symbol Column 1	Affymetrix Probeset name Column 2	Gene Name Column 3	Gene Accession Number Column 4	Protein Accession Number Column 5
			NM_181296	NP_851813
			NM_181297	NP_851814
			NM_181298	NP_851815
			NM_181299	NP_851816
			NM_181300	NP_851817
			NM_181301	NP_851818
CLEC10A	206682_at	C-TYPE LECTIN DOMAIN FAMILY 10, MEMBER A	NM_006344	NP_006335
CLEC4D	1552772_at	C-TYPE LECTIN DOMAIN FAMILY 4, MEMBER D	NM_182906	NP_878910
CLEC4E	219859_at	C-TYPE LECTIN DOMAIN FAMILY 4, MEMBER E	NM_014358	NP_055173
CLEC5A	219890_at	C-TYPE LECTIN DOMAIN FAMILY 5, MEMBER A	NM_013252	NP_037384
COL4A3BP	223465_at	COLLAGEN, TYPE IV, ALPHA 3 (GOODPASTURE ANTIGEN) BINDING PROTEIN	NM_005713	NP_005704
			NM_031361	NP_112729
COP1	1552701_a_at	CARD ONLY PROTEIN	NM_052889	NP_443121
COX15	235204_at	COX15 HOMOLOG, CYTOCHROME C OXIDASE ASSEMBLY PROTEIN (YEAST)	NM_004376	NP_004367
			NM_078470	NP_510870
CPD	201941_at	CARBOXYPEPTIDASE D	NM_001304	NP_001295
CPD	201940_at	CARBOXYPEPTIDASE D	NM_001304	NP_001295
CPEB4	242384_at	CYTOPLASMIC POLYADENYLATION ELEMENT BINDING PROTEIN 4	NM_030627	NP_085130
CPEB4	224829_at	CYTOPLASMIC POLYADENYLATION ELEMENT BINDING PROTEIN 4	NM_030627	NP_085130
CPVL	208146_s_at	CARBOXYPEPTIDASE, VITELLOGENIC-LIKE	NM_019029	NP_061902
			NM_031311	NP_112601
CR1	206244_at	COMPLEMENT COMPONENT (3B/4B) RECEPTOR 1, INCLUDING KNOPS BLOOD GROUP SYSTEM	NM_000573	NP_000564
			NM_000651	NP_000642
CRTAP	1554464_a_at	CARTILAGE-ASSOCIATED PROTEIN	NM_006371	NP_006362
CRTAP	1555889_a_at	CARTILAGE-ASSOCIATED PROTEIN	NM_006371	NP_006362
CSF1R	203104_at	COLONY STIMULATING FACTOR 1 RECEPTOR, FORMERLY MCDONOUGH FELINE SARCOMA VIRAL (V-FMS) ONCOGENE HOMOLOG	NM_005211	NP_005202
CTGLF1	221850_x_at	CENTAURIN, GAMMA- LIKE FAMILY, MEMBER 1	NM_133446	NP_597703
CYP4F2	210452_x_at	CYTOCHROME P450, FAMILY 4, SUBFAMILY F, POLYPEPTIDE 2	NM_001082	NP_001073
DCP2	235258_at	DCP2 DECAPPING ENZYME HOMOLOG (S. <i>CEREVISIAE</i>)	NM_152624	NP_689837
DDAH2	202262_x_at	DIMETHYLARGININE DIMETHYLAMINOHYDROLASE 2	NM_013974	NP_039268
DDAH2	215537_x_at	DIMETHYLARGININE DIMETHYLAMINOHYDROLASE 2	NM_013974	NP_039268
DDAH2	214909_s_at	DIMETHYLARGININE DIMETHYLAMINOHYDROLASE 2	NM_013974	NP_039268
DDX26	222239_s_at	DEAD/H (Asp-Glu-Ala- Asp/His) BOX POLYPEPTIDE 26	NM_012141	NP_036273

TABLE 30-continued

Exemplary biomarkers that discriminate between responders and nonresponders				
Gene Symbol Column 1	Affymetrix Probeset name Column 2	Gene Name Column 3	Gene Accession Number Column 4	Protein Accession Number Column 5
DHRS9	223952_x_at	MEMBRANE PROTEIN, PALMITOYLATED 3; MPP3	NM_005771 NM_199204	NP_005762 NP_954674
DHRS9	224009_x_at	MEMBRANE PROTEIN, PALMITOYLATED 3; MPP3	NM_005771 NM_199204	NP_005762 NP_954674
DHRS9	219799_s_at	MEMBRANE PROTEIN, PALMITOYLATED 3; MPP3	NM_005771 NM_199204	NP_005762 NP_954674
DKFZP564B1023	228385_at	KINESIN FAMILY MEMBER 14 (KIF14)	XM_375825	XP_375825
DKFZP566M1046	223637_s_at	HYPOTHETICAL PROTEIN DKFZP566M1046	NM_032127	NP_115503
DKFZp667F0711	1559756_at	HYPOTHETICAL PROTEIN DKFZp667F0711	XM_374767	XP_374767
DLGAP1	239421_at	DISCS, LARGE (<i>DROSOPHILA</i>) HOMOLOG-ASSOCIATED PROTEIN 1	NM_001003809 NM_004746	NP_001003809 NP_004737
DNAJA1	200881_s_at	DNAJ (HSP40) HOMOLOG, SUBFAMILY A, MEMBER 1	NM_001539	NP_001530
DR1	216652_s_at	DOWN-REGULATOR OF TRANSCRIPTION 1, TBP- BINDING (NEGATIVE COFACTOR 2)	NM_001938	NP_001929
E2F3	203693_s_at	E2F TRANSCRIPTION FACTOR 3	NM_001949	NP_001940
EFHC1	225656_at	EF-HAND DOMAIN (C- TERMINAL) CONTAINING 1	NM_018100	NP_060570
EGFL5	212831_at	EGF-LIKE-DOMAIN, MULTIPLE 5	XM_376905	XP_376905
EIF4E	201435_s_at	EUKARYOTIC TRANSLATION INITIATION FACTOR 4E	NM_001968	NP_001959
EIF4E3	225941_at	EUKARYOTIC TRANSLATION INITIATION FACTOR 4E MEMBER 3	NM_173359	NP_775495
EIF4E3	225940_at	EUKARYOTIC TRANSLATION INITIATION FACTOR 4E MEMBER 3	NM_173359	NP_775495
EIF4E3	238461_at	EUKARYOTIC TRANSLATION INITIATION FACTOR 4E MEMBER 3	NM_173359	NP_775495
EIF4G3	201935_s_at	EUKARYOTIC TRANSLATION INITIATION FACTOR 4- GAMMA, 3	NM_003760	NP_003751
EIF4G3	201936_s_at	EUKARYOTIC TRANSLATION INITIATION FACTOR 4- GAMMA, 3	NM_003760	NP_003751
EIF4G3	243149_at	EUKARYOTIC TRANSLATION INITIATION FACTOR 4- GAMMA, 3	NM_003760	NP_003751
EMILIN2	242288_s_at	ELASTIN MICROFIBRIL INTERFACER 2	NM_032048	NP_114437
ETS2	201328_at	V-ETS ERYTHROBLASTOSIS VIRUS E26 ONCOGENE HOMOLOG 2 (AVIAN)	NM_005239	NP_005230
EXOSC4	91684_g_at	EXOSOME COMPONENT 4	NM_019037	NP_061910
EXOSC4	218695_at	EXOSOME COMPONENT 4	NM_019037	NP_061910
EXOSC4	58696_at	EXOSOME COMPONENT 4	NM_019037	NP_061910
FAD104	244022_at	FIBRONECTIN TYPE III DOMAIN CONTAINING 3B (FNDC3B)	NM_022763	NP_073600

TABLE 30-continued

Exemplary biomarkers that discriminate between responders and nonresponders				
Gene Symbol Column 1	Affymetrix Probeset name Column 2	Gene Name Column 3	Gene Accession Number Column 4	Protein Accession Number Column 5
FAM53C	218023_s_at	FAMILY WITH SEQUENCE SIMILARITY 53, MEMBER C	NM_016605	NP_057689
FAS	204781_s_at	FAS (TNF RECEPTOR SUPERFAMILY, MEMBER 6)	NM_000043 NM_152871 NM_152872 NM_152873 NM_152874 NM_152875 NM_152876 NM_152877	NP_000034 NP_690610 NP_690611 NP_690612 NP_690613 NP_690614 NP_690615 NP_690616
FAS	204780_s_at	FAS (TNF RECEPTOR SUPERFAMILY, MEMBER 6)	NM_000043 NM_152871 NM_152872 NM_152873 NM_152874 NM_152875 NM_152876 NM_152877	NP_000034 NP_690610 NP_690611 NP_690612 NP_690613 NP_690614 NP_690615 NP_690616
FBXL13	1553798_a_at	F-BOX AND LEUCINE- RICH REPEAT PROTEIN 13	NM_145032	NP_659469
FBXO9	1559094_at	F-BOX PROTEIN 9	NM_012347 NM_033480 NM_033481	NP_036479 NP_258441 NP_258442
FBXO9	1559096_x_at	F-BOX PROTEIN 9	NM_012347 NM_033480 NM_033481	NP_036479 NP_258441 NP_258442
FCAR	211307_s_at	FC FRAGMENT OF IGA, RECEPTOR FOR	NM_002000 NM_133269 NM_133271 NM_133272 NM_133273 NM_133274 NM_133277 NM_133278 NM_133279 NM_133280	NP_001991 NP_579803 NP_579805 NP_579806 NP_579807 NP_579808 NP_579811 NP_579812 NP_579813 NP_579814
FCAR	211306_s_at	FC FRAGMENT OF IGA, RECEPTOR FOR	NM_002000 NM_133269 NM_133271 NM_133272 NM_133273 NM_133274 NM_133277 NM_133278 NM_133279 NM_133280	NP_001991 NP_579803 NP_579805 NP_579806 NP_579807 NP_579808 NP_579811 NP_579812 NP_579813 NP_579814
FCAR	207674_at	FC FRAGMENT OF IGA, RECEPTOR FOR	NM_002000 NM_133269 NM_133271 NM_133272 NM_133273 NM_133274 NM_133277 NM_133278 NM_133279 NM_133280	NP_001991 NP_579803 NP_579805 NP_579806 NP_579807 NP_579808 NP_579811 NP_579812 NP_579813 NP_579814
FCAR	211305_x_at	FC FRAGMENT OF IGA, RECEPTOR FOR	NM_002000 NM_133269 NM_133271 NM_133272 NM_133273 NM_133274 NM_133277 NM_133278 NM_133279 NM_133280	NP_001991 NP_579803 NP_579805 NP_579806 NP_579807 NP_579808 NP_579811 NP_579812 NP_579813 NP_579814

TABLE 30-continued

Exemplary biomarkers that discriminate between responders and nonresponders				
Gene Symbol Column 1	Affymetrix Probeset name Column 2	Gene Name Column 3	Gene Accession Number Column 4	Protein Accession Number Column 5
FCGR1A	216950_s_at	FC FRAGMENT OF IGG, HIGH AFFINITY IA	NM_000566	NP_000557
FCGR1A	216951_at	FC FRAGMENT OF IGG, HIGH AFFINITY IA	NM_000566	NP_000557
FCGR1A LOC440607	214511_x_at			
FEM1C	213341_at	FEM-1 HOMOLOG C (<i>C. ELEGANS</i>)	NM_020177	NP_064562
FLJ10213	219906_at	HYPOTHETICAL PROTEIN FLJ10213	NM_018029	NP_060499
FLJ10521	1570511_at	HYPOTHETICAL PROTEIN FLJ10521	NM_001011722 NM_018125	NP_001011722 NP_060595
FLJ11011	222657_s_at	HYPOTHETICAL PROTEIN FLJ11011	NM_001001481 NM_001001482 NM_018299	NP_001001481 NP_001001482 NP_060769
FLJ11259	218627_at	HYPOTHETICAL PROTEIN FLJ11259	NM_018370	NP_060840
FLJ11795	220112_at	HYPOTHETICAL PROTEIN FLJ11795	NM_024669	NP_078945
FLJ12770	226059_at	HYPOTHETICAL PROTEIN FLJ12770	NM_032174	NP_115550
FLJ13154	218060_s_at	HYPOTHETICAL PROTEIN FLJ13154	NM_024598	NP_078874
FLJ13448	219397_at	HYPOTHETICAL PROTEIN FLJ13448	NM_025147	NP_079423
FLJ14001	238983_at	HYPOTHETICAL PROTEIN FLJ14001	NM_024677	NP_078953
FLJ20273	218035_s_at	RNA-BINDING PROTEIN	NM_019027	NP_061900
FLJ20273	222496_s_at	RNA-BINDING PROTEIN	NM_019027	NP_061900
FLJ20481	227889_at	HYPOTHETICAL PROTEIN FLJ20481	NM_017839	NP_060309
FLJ20481	222833_at	HYPOTHETICAL PROTEIN FLJ20481	NM_017839	NP_060309
FLJ20701	219093_at	HYPOTHETICAL PROTEIN FLJ20701	NM_017933	NP_060403
FLJ22833	219334_s_at	HYPOTHETICAL PROTEIN FLJ22833	NM_022837	NP_073748
FLJ22833	233085_s_at	HYPOTHETICAL PROTEIN FLJ22833	NM_022837	NP_073748
FLJ22833	222872_x_at	HYPOTHETICAL PROTEIN FLJ22833	NM_022837	NP_073748
FLJ23231	218810_at	MCP-1 TREATMENT- INDUCED PROTEIN (MCPIP)	NM_025079	NP_079355
FLJ25416	228281_at	HYPOTHETICAL PROTEIN FLJ25416	NM_145018	NP_659455
FLJ31033	228152_s_at	HYPOTHETICAL PROTEIN FLJ31033	XM_037817 XM_376353	XP_037817 XP_376353
FLJ36031	226756_at	HYPOTHETICAL PROTEIN FLJ36031	NM_175884	NP_787080
FLJ37858	227354_at	FLJ37858 PROTEIN	NM_001007549	NP_001007550
FLOT1	210142_x_at	FLOTILLIN 1	NM_005803	NP_005794
FNDC3B	225032_at	FIBRONECTIN TYPE III DOMAIN CONTAINING 3B	NM_022763	NP_073600
FNDC3B	222692_s_at	FIBRONECTIN TYPE III DOMAIN CONTAINING 3B	NM_022763	NP_073600
FNDC3B	222693_at	FIBRONECTIN TYPE III DOMAIN CONTAINING 3B	NM_022763	NP_073600
FNDC3B	229865_at	FIBRONECTIN TYPE III DOMAIN CONTAINING 3B	NM_022763	NP_073600
FNDC3B	218618_s_at	FIBRONECTIN TYPE III DOMAIN CONTAINING 3B	NM_022763	NP_073600
FTS	218373_at	FUSED TOES HOMOLOG (MOUSE)	NM_001012398 NM_022476	NP_001012398 NP_071921
FYB	227266_s_at	FYN BINDING PROTEIN (FYB-120/130)	NM_001465 NM_199335	NP_001456 NP_955367

TABLE 30-continued

Exemplary biomarkers that discriminate between responders and nonresponders				
Gene Symbol Column 1	Affymetrix Probeset name Column 2	Gene Name Column 3	Gene Accession Number Column 4	Protein Accession Number Column 5
FYB	211795_s_at	FYN BINDING PROTEIN (FYB-120/130)	NM_001465 NM_199335	NP_001456 NP_955367
G0S2	213524_s_at	PUTATIVE LYMPHOCYTE G0/G1 SWITCH GENE	NM_015714	NP_056529
GAB2	238405_at	GRB2-ASSOCIATED BINDING PROTEIN 2	NM_012296 NM_080491	NP_036428 NP_536739
GADD45A	203725_at	GROWTH ARREST AND DNA-DAMAGE- INDUCIBLE, ALPHA	NM_001924	NP_001915
GADD45B	209304_x_at	GROWTH ARREST-AND DNA DAMAGE- INDUCIBLE GENE GADD45	NM_015675	NP_056490
GADD45B	207574_s_at	GROWTH ARREST-AND DNA DAMAGE- INDUCIBLE GENE GADD45	NM_015675	NP_056490
GALNT3	203397_s_at	UDP-N-ACETYL-ALPHA-D- GALACTOSAMINE:POLYPEPTIDE N- ACETYLGALACTOSAMINYL TRANSFERASE 3 (GALNAC-T3)	NM_004482	NP_004473
GBA	210589_s_at	GLUCOSIDASE, BETA; ACID (INCLUDES GLUCOSYLCERAMIDASE)	NM_000157 NM_001005741 NM_001005742 NM_001005749 NM_001005750	NP_000148 NP_001005741 NP_001005742 NP_001005749 NP_001005750
GBA	209093_s_at	GLUCOSIDASE, BETA; ACID (INCLUDES GLUCOSYLCERAMIDASE)	NM_000157 NM_001005741 NM_001005742 NM_001005749 NM_001005750	NP_000148 NP_001005741 NP_001005742 NP_001005749 NP_001005750
GBP2	242907_at	GUANYLATE BINDING PROTEIN 2, INTERFERON- INDUCIBLE	NM_004120	NP_004111
GCA	203765_at	GRANCALCIN, EF-HAND CALCIUM BINDING PROTEIN	NM_012198	NP_036330
GCLM	203925_at	GLUTAMATE-CYSTEINE LIGASE, MODIFIER SUBUNIT	NM_002061	NP_002052
GK	214681_at	GLYCEROL KINASE	NM_000167 NM_203391	NP_000158 NP_976325
GK	207387_s_at	GLYCEROL KINASE	NM_000167 NM_203391	NP_000158 NP_976325
GK	217167_x_at	GLYCEROL KINASE	NM_000167 NM_203391	NP_000158 NP_976325
GK	216316_x_at	GLYCEROL KINASE	NM_000167 NM_203391	NP_000158 NP_976325
GK	215977_x_at	GLYCEROL KINASE	NM_000167 NM_203391	NP_000158 NP_976325
GNAI3	201180_s_at	GUANINE NUCLEOTIDE BINDING PROTEIN (G PROTEIN), ALPHA INHIBITING ACTIVITY POLYPEPTIDE 3	NM_006496	NP_006487
GNG5	207157_s_at	GUANINE NUCLEOTIDE BINDING PROTEIN (G PROTEIN), GAMMA 5	NM_005274	NP_005265
GNS	212335_at	GLUCOSAMINE (N- ACETYL)-6-SULFATASE (SANFILIPPO DISEASE IIID)	NM_002076	NP_002067
GPR160	223423_at	G PROTEIN-COUPLED RECEPTOR 160	NM_014373	NP_055188

TABLE 30-continued

Exemplary biomarkers that discriminate between responders and nonresponders				
Gene Symbol Column 1	Affymetrix Probeset name Column 2	Gene Name Column 3	Gene Accession Number Column 4	Protein Accession Number Column 5
GPR43	221345_at	G PROTEIN-COUPLED RECEPTOR 43	NM_005306	NP_005297
GPR84	223767_at	G PROTEIN-COUPLED RECEPTOR 84	NM_020370	NP_065103
GPR97	220404_at	G PROTEIN-COUPLED RECEPTOR 97	NM_170776	NP_740746
GTDC1	219770_at	GLYCOSYLTRANSFERASE- LIKE DOMAIN CONTAINING 1	NM_001006636 NM_024659	NP_001006637 NP_078935
GTF2B	208066_s_at	GENERAL TRANSCRIPTION FACTOR IIB	NM_001514	NP_001505
GYG	201554_x_at	GLYCOGENIN	NM_004130	NP_004121
GYG	211275_s_at	GLYCOGENIN	NM_004130	NP_004121
HAGH	205012_s_at	HYDROXYACYLGLUTATHIONE HYDROLASE	NM_005326	NP_005317
HDAC4	204225_at	HISTONE DEACETYLASE 4	NM_006037	NP_006028
HGF	209960_at	HEPATOCTE GROWTH FACTOR (HEPAPOIETIN A; SCATTER FACTOR)	NM_000601 NM_001010931 NM_001010932 NM_001010933 NM_001010934 NM_005338	NP_000592 NP_001010931 NP_001010932 NP_001010933 NP_001010934 NP_005329
HIP1	226364_at	HUNTINGTIN INTERACTING PROTEIN 1	NM_005338	NP_005329
HIP1	205425_at	HUNTINGTIN INTERACTING PROTEIN 1	NM_005338	NP_005329
HIP1	205426_s_at	HUNTINGTIN INTERACTING PROTEIN 1	NM_005338	NP_005329
HIST1H2BD	209911_x_at	HISTONE 1, H2BD	NM_021063 NM_138720	NP_066407 NP_619790
HIST2H2AA	214290_s_at	HISTONE 2, H2AA	NM_003516	NP_003507
HLA-DMA	217478_s_at	HLA-D HISTOCOMPATIBILITY TYPE	NM_006120	NP_006111
HLA-DMB	203932_at	MAJOR HISTOCOMPATIBILITY COMPLEX, CLASS II, DM BETA	NM_002118	NP_002109
HLA-DPA1	211990_at	MAJOR HISTOCOMPATIBILITY COMPLEX, CLASS II, DP ALPHA 1	NM_033554	NP_291032
HLA-DPA1	211991_s_at	MAJOR HISTOCOMPATIBILITY COMPLEX, CLASS II, DP ALPHA 1	NM_033554	NP_291032
HLA-DPB1	201137_s_at	MAJOR HISTOCOMPATIBILITY COMPLEX, CLASS II, DP BETA 1	NM_002121	NP_002112
HLA-DQB1	209823_x_at	MAJOR HISTOCOMPATIBILITY COMPLEX, CLASS II, DQ BETA 1	NM_002123	NP_002114
HLA-DQB1	211656_x_at	MAJOR HISTOCOMPATIBILITY COMPLEX, CLASS II, DQ BETA 1	NM_002123	NP_002114
HLA-DRA	208894_at	MAJOR HISTOCOMPATIBILITY COMPLEX, CLASS II, DR ALPHA	NM_002123	NP_002114
HLA-DRA	210982_s_at	MAJOR HISTOCOMPATIBILITY COMPLEX, CLASS II, DR ALPHA	NM_002123	NP_002114

TABLE 30-continued

Exemplary biomarkers that discriminate between responders and nonresponders				
Gene Symbol Column 1	Affymetrix Probeset name Column 2	Gene Name Column 3	Gene Accession Number Column 4	Protein Accession Number Column 5
HLA-DRB1	208306_x_at	MAJOR HISTOCOMPATIBILITY COMPLEX, CLASS II, DR BETA 1	NM_002124	NP_002115
HLA-DRB1	204670_x_at	MAJOR HISTOCOMPATIBILITY COMPLEX, CLASS II, DR BETA 1	NM_002124	NP_002115
HLA-DRB1	209312_x_at	MAJOR HISTOCOMPATIBILITY COMPLEX, CLASS II, DR BETA 1	NM_002124	NP_002115
HLA-DRB1	215193_x_at	MAJOR HISTOCOMPATIBILITY COMPLEX, CLASS II, DR BETA 1	NM_002124	NP_002115
HNRPLL	241692_at	HETEROGENEOUS NUCLEAR RIBONUCLEOPROTEIN L- LIKE	NM_138394	NP_612403
HPGD	203913_s_at	HYDROXYPROSTAGLAND IN DEHYDROGENASE 15- (NAD)	NM_000860	NP_000851
HRPT2	218578_at	HYPERPARATHYROIDISM 2 (WITH JAW TUMOR)	NM_024529	NP_078805
HSPC163	228306_at	HSPC163 PROTEIN	NM_014184	NP_054903
HSPC163	218728_s_at	HSPC163 PROTEIN	NM_014184	NP_054903
HSPC163	228437_at	HSPC163 PROTEIN	NM_014184	NP_054903
HSPC163	223993_s_at	HSPC163 PROTEIN	NM_014184	NP_054903
HSPC163	243051_at	HSPC163 PROTEIN	NM_014184	NP_054903
HSPCA	214328_s_at	HEAT SHOCK 90 KDA PROTEIN 1, ALPHA	NM_005348	NP_005339
HTATIP2	209448_at	HIV-1 TAT INTERACTIVE PROTEIN 2, 30 KDA	NM_006410	NP_006401
HTATIP2	210253_at	HIV-1 TAT INTERACTIVE PROTEIN 2, 30 KDA	NM_006410	NP_006401
IDI1	204615_x_at	ISOPENTENYL- DIPHOSPHATE DELTA ISOMERASE	NM_004508	NP_004499
IDI1	208881_x_at	ISOPENTENYL- DIPHOSPHATE DELTA ISOMERASE	NM_004508	NP_004499
IFNAR1	225669_at	INTERFERON (ALPHA, BETA AND OMEGA) RECEPTOR 1	NM_000629	NP_000620
IFNAR1	225661_at	INTERFERON (ALPHA, BETA AND OMEGA) RECEPTOR 1	NM_000629	NP_000620
IFNAR2	204786_s_at	INTERFERON (ALPHA, BETA AND OMEGA) RECEPTOR 2	NM_000874 NM_207584 NM_207585	NP_000865 NP_997467 NP_997468
IFNGR1	202727_s_at	INTERFERON GAMMA RECEPTOR 1	NM_000416	NP_000407
IGSF2	207167_at	IMMUNOGLOBULIN SUPERFAMILY, MEMBER 2	NM_004258	NP_004249
IL10RA	204912_at	INTERLEUKIN 10 RECEPTOR, ALPHA	NM_001558	NP_001549
IL18R1	206618_at	INTERLEUKIN 18 RECEPTOR 1	NM_003855	NP_003846
IL1R1	202948_at	INTERLEUKIN 1 RECEPTOR, TYPE I	NM_000877	NP_000868
IL1R2	211372_s_at	INTERLEUKIN 1 RECEPTOR, TYPE II	NM_004633 NM_173343	NP_004624 NP_775465
IL1R2	205403_at	INTERLEUKIN 1 RECEPTOR, TYPE II	NM_004633 NM_173343	NP_004624 NP_775465

TABLE 30-continued

Exemplary biomarkers that discriminate between responders and nonresponders				
Gene Symbol Column 1	Affymetrix Probeset name Column 2	Gene Name Column 3	Gene Accession Number Column 4	Protein Accession Number Column 5
IL1RAP	205227_at	INTERLEUKIN 1 RECEPTOR ACCESSORY PROTEIN	NM_002182 NM_134470	NP_002173 NP_608273
INSL3	214572_s_at	INSULIN-LIKE 3 (LEYDIG CELL)	NM_005543	NP_005534
IRAK2	231779_at	INTERLEUKIN-1 RECEPTOR-ASSOCIATED KINASE 2	NM_001570	NP_001561
IRAK3	220034_at	INTERLEUKIN-1 RECEPTOR-ASSOCIATED KINASE 3	NM_007199	NP_009130
IRAK4	219618_at	INTERLEUKIN-1 RECEPTOR-ASSOCIATED KINASE 4	NM_016123	NP_057207
ITGAM	205786_s_at	INTEGRIN, ALPHA M (COMPLEMENT COMPONENT RECEPTOR 3, ALPHA; ALSO KNOWN AS CD11B (P170), MACROPHAGE ANTIGEN ALPHA POLYPEPTIDE)	NM_000632	NP_000623
ITGB3	216261_at	INTEGRIN, BETA 3 (PLATELET GLYCOPROTEIN IIIA, ANTIGEN CD61)	NM_000212	NP_000203
IVNS1ABP	201362_at	INFLUENZA VIRUS NS1A BINDING PROTEIN	NM_006469 NM_016389	NP_006460 NP_057473
JAK2	205842_s_at	JANUS KINASE 2 (A PROTEIN TYROSINE KINASE)	NM_004972	NP_004963
JAK2	205841_at	JANUS KINASE 2 (A PROTEIN TYROSINE KINASE)	NM_004972	NP_004963
JAK3	211108_s_at	JANUS KINASE 3 (A PROTEIN TYROSINE KINASE, LEUKOCYTE)	NM_000215	NP_000206
JAK3	227677_at	JANUS KINASE 3 (A PROTEIN TYROSINE KINASE, LEUKOCYTE)	NM_000215	NP_000206
JUNB	201473_at	JUN B PROTO-ONCOGENE	NM_002229	NP_002220
KCNE1	236407_at	POTASSIUM VOLTAGE- GATED CHANNEL, ISK- RELATED FAMILY, MEMBER 1	NM_000219	NP_000210
KCNJ15	238428_at	POTASSIUM INWARDLY- RECTIFYING CHANNEL, SUBFAMILY J, MEMBER 15	NM_002243 NM_170736 NM_170737	NP_002234 NP_733932 NP_733933
KCNJ15	210119_at	POTASSIUM INWARDLY- RECTIFYING CHANNEL, SUBFAMILY J, MEMBER 15	NM_002243 NM_170736 NM_170737	NP_002234 NP_733932 NP_733933
KIAA0040	203144_s_at	KIAA0040	NM_014656	NP_055471
KIAA0103	203584_at	KIAA0103	NM_014673	NP_055488
KIAA0182	212057_at	KIAA0182 PROTEIN	NM_014615	NP_055430
KIAA0261	212264_s_at	KIAA0261	NM_015045	NP_055860
KIAA0635	206003_at	CENTROSOMAL PROTEIN 4	NM_025009	NP_079285
KIAA0746	212314_at	KIAA0746 PROTEIN	NM_015187	NP_056002
KIAA1160	223831_x_at	KIAA1160 PROTEIN	NM_020701	NP_065752
KIAA1533	244808_at	KIAA1533	NM_020895	NP_065946
KIAA1533	224807_at	KIAA1533	NM_020895	NP_065946
KIAA1600	226155_at	KIAA1600	NM_020940	NP_065991
KIAA1632	227638_at	KIAA1632	NM_020964	NP_066015
KIAA1991	242808_at	HYPOTHETICAL PROTEIN KIAA1991	XM_495886	XP_495886

TABLE 30-continued

Exemplary biomarkers that discriminate between responders and nonresponders				
Gene Symbol Column 1	Affymetrix Probeset name Column 2	Gene Name Column 3	Gene Accession Number Column 4	Protein Accession Number Column 5
KIF1B	225878_at	KINESIN FAMILY MEMBER 1B	NM_015074 NM_183416	NP_055889 NP_904325
KIF1B	209234_at	KINESIN FAMILY MEMBER 1B	NM_015074 NM_183416	NP_055889 NP_904325
KIF1B	241216_at	KINESIN FAMILY MEMBER 1B	NM_015074 NM_183416	NP_055889 NP_904325
KLF11	218486_at	KRUPPEL-LIKE FACTOR 11	NM_003597	NP_003588
KLF7	204334_at	KRUPPEL-LIKE FACTOR 7 (UBIQUITOUS)	NM_003709	NP_003700
KLHL2	219157_at	KELCH-LIKE 2, MAYVEN (<i>DROSOPHILA</i>)	NM_007246	NP_009177
KLHL6	1560396_at	KELCH-LIKE 6 (<i>DROSOPHILA</i>)	NM_130446	NP_569713
KPNA4	225267_at	KARYOPHERIN ALPHA 4 (IMPORTIN ALPHA 3)	NM_002268	NP_002259
KPNA4	209653_at	KARYOPHERIN ALPHA 4 (IMPORTIN ALPHA 3)	NM_002268	NP_002259
KREMEN1	227250_at	KRINGLE CONTAINING TRANSMEMBRANE PROTEIN 1	NM_032045 NM_153379	NP_114434 NP_700358
KREMEN1	235370_at	KRINGLE CONTAINING TRANSMEMBRANE PROTEIN 1	NM_032045 NM_153379	NP_114434 NP_700358
KREMEN1	224534_at	KRINGLE CONTAINING TRANSMEMBRANE PROTEIN 1	NM_032045 NM_153379	NP_114434 NP_700358
LDLR	202068_s_at	LOW DENSITY LIPOPROTEIN RECEPTOR	NM_000527	NP_000518
LFNG	228762_at	LUNATIC FRINGE HOMOLOG (<i>DROSOPHILA</i>)	NM_002304	NP_002295
LGALS8	208934_s_at	LECTIN, GALACTOSIDE- BINDING, SOLUBLE, 8 (GALECTIN 8)	NM_006499 NM_201543 NM_201544 NM_201545	NP_006490 NP_963837 NP_963838 NP_963839
LIMK2	1561654_at	LIM DOMAIN KINASE 2	NM_005569 NM_016733	NP_005560 NP_057952
LIMK2	202193_at	LIM DOMAIN KINASE 2	NM_005569 NM_016733	NP_005560 NP_057952
LIMK2	210582_s_at	LIM DOMAIN KINASE 2	NM_005569 NM_016733	NP_005560 NP_057952
LIMK2	217475_s_at	LIM DOMAIN KINASE 2	NM_005569 NM_016733	NP_005560 NP_057952
LIN7A	240027_at	LIN-7 HOMOLOG A (<i>C. ELEGANS</i>)	NM_004664	NP_004655
LIN7A	206440_at	LIN-7 HOMOLOG A (<i>C. ELEGANS</i>)	NM_004664	NP_004655
LIR9	1555634_a_at	LEUKOCYTE IMMUNOGLOBULIN-LIKE RECEPTOR, SUBFAMILY B (WITH TM AND ITIM DOMAINS), MEMBER 7 (LILRB7)	NM_021250 NM_181879 NM_181985 NM_181986	NP_067073 NP_870994 NP_871714 NP_871715
LMNB1	203276_at	LAMIN B1	NM_005573	NP_005564
LMTK2	226375_at	LEMUR TYROSINE KINASE 2	NM_014916	NP_055731
LOC145758	226513_at	HYPOTHETICAL PROTEIN LOC145758		
LOC153561	232889_at	HYPOTHETICAL PROTEIN LOC153561	NM_207331	NP_997214
LOC199675	235568_at	HYPOTHETICAL PROTEIN LOC199675	NM_174918	NP_777578
LOC220929	229743_at	HYPOTHETICAL PROTEIN LOC220929	NM_182755	NP_877432
LOC285771	237870_at	HYPOTHETICAL PROTEIN LOC285771		
LOC286044	222662_at	HYPOTHETICAL PROTEIN LOC286044		

TABLE 30-continued

Exemplary biomarkers that discriminate between responders and nonresponders				
Gene Symbol Column 1	Affymetrix Probeset name Column 2	Gene Name Column 3	Gene Accession Number Column 4	Protein Accession Number Column 5
LOC338758	238893_at	HYPOTHETICAL PROTEIN LOC338758		
LOC401152	224602_at	HCV F-TRANSACTIVATED PROTEIN 1	NM_001001701	NP_001001701
LOC440731	237563_s_at	LOC440731	XM_498838	XP_498838
LOC440823	227168_at			
LOC57149	203897_at	HYPOTHETICAL PROTEIN A-211C6.1	NM_020424	NP_065157
LOC88523	214748_at	CG016	NM_033111	NP_149102
LRG1	228648_at	LEUCINE-RICH ALPHA-2- GLYCOPROTEIN 1	NM_052972	NP_443204
LRPAP1	201186_at	LOW DENSITY LIPOPROTEIN RECEPTOR- RELATED PROTEIN ASSOCIATED PROTEIN 1	NM_002337	NP_002328
LRRC17	1560527_at	LEUCINE RICH REPEAT CONTAINING 17	NM_005824	NP_005815
LTB4R	236172_at	LEUKOTRIENE B4 RECEPTOR	NM_181657	NP_858043
LTBP2	204682_at	LATENT TRANSFORMING GROWTH FACTOR BETA BINDING PROTEIN 2	NM_000428	NP_000419
LY86	205859_at	LYMPHOCYTE ANTIGEN 86	NM_004271	NP_004262
LY96	206584_at	LYMPHOCYTE ANTIGEN 96	NM_015364	NP_056179
MAP2K1IP1	217971_at	MITOGEN-ACTIVATED PROTEIN KINASE KINASE 1 INTERACTING PROTEIN 1	NM_021970	NP_068805
MAP2K6	205698_s_at	MITOGEN-ACTIVATED PROTEIN KINASE KINASE 6	NM_002758	NP_002749
MAPK14	210449_x_at	MAPK14 MITOGEN- ACTIVATED PROTEIN KINASE 14	NM_031988 NM_001315 NM_139012 NM_139013 NM_139014	NP_114365 NP_001306 NP_620581 NP_620582 NP_620583
MAPK14	211561_x_at	MAPK14 MITOGEN- ACTIVATED PROTEIN KINASE 14	NM_001315 NM_139012 NM_139013 NM_139014	NP_001306 NP_620581 NP_620582 NP_620583
MAPK14	211087_x_at	MAPK14 MITOGEN- ACTIVATED PROTEIN KINASE 14	NM_001315 NM_139012 NM_139013 NM_139014	NP_001306 NP_620581 NP_620582 NP_620583
MAPK14	202530_at	MAPK14 MITOGEN- ACTIVATED PROTEIN KINASE 14	NM_001315 NM_139012 NM_139013 NM_139014	NP_001306 NP_620581 NP_620582 NP_620583
MARCKSL1	200644_at	MARCKS-LIKE 1	NM_023009	NP_075385
MCTP2	220603_s_at	MULTIPLE C2-DOMAINS WITH TWO TRANSMEMBRANE REGIONS 2	NM_018349	NP_060819
MCTP2	229005_at	MULTIPLE C2-DOMAINS WITH TWO TRANSMEMBRANE REGIONS 2	NM_018349	NP_060819
MCTP2	239893_at	MULTIPLE C2-DOMAINS WITH TWO TRANSMEMBRANE REGIONS 2	NM_018349	NP_060819
MEF2A	214684_at	MADS BOX TRANSCRIPTION ENHANCER FACTOR 2, POLYPEPTIDE A (MYOCYTE ENHANCER FACTOR 2A)	NM_005587	NP_005578

TABLE 30-continued

Exemplary biomarkers that discriminate between responders and nonresponders				
Gene Symbol Column 1	Affymetrix Probeset name Column 2	Gene Name Column 3	Gene Accession Number Column 4	Protein Accession Number Column 5
MEF2C	236395_at	MADS BOX TRANSCRIPTION ENHANCER FACTOR 2, POLYPEPTIDE C (MYOCYTE ENHANCER FACTOR 2C)	NM_002397	NP_002388
MGC11324	224480_s_at	HYPOTHETICAL PROTEIN MGC11324	NM_032717	NP_116106
MGC15619	226879_at	HYPOTHETICAL PROTEIN MGC15619	NM_032369	NP_115745
MGC15887	226448_at	HYPOTHETICAL GENE SUPPORTED BY BC009447	NM_198552	NP_940954
MGC17301	227055_at	HYPOTHETICAL PROTEIN MGC17301	NM_152637	NP_689850
MGC23280	226121_at	HYPOTHETICAL PROTEIN MGC23280	NM_144683	NP_653284
MKNK1	209467_s_at	MAP KINASE INTERACTING SERINE/THREONINE KINASE 1	NM_003684 NM_198973	NP_003675 NP_945324
MLKL	238025_at	MIXED LINEAGE KINASE DOMAIN-LIKE	NM_152649	NP_689862
MLLT2	201924_at	MYELOID/LYMPHOID OR MIXED-LINEAGE LEUKEMIA (TRITHORAX HOMOLOG, <i>DROSOPHILA</i>); TRANSLOCATED TO, 2	NM_005935	NP_005926
MMP9	203936_s_at	MATRIX METALLOPROTEINASE 9 (GELATINASE B, 92 KDA GELATINASE, 92 KDA TYPE IV COLLAGENASE)	NM_004994	NP_004985
MOBK1B	201298_s_at	MOB1, MPS ONE BINDER KINASE ACTIVATOR-LIKE 1B (YEAST)	NM_018221	NP_060691
MOBK1C	227066_at	MOB1, MPS ONE BINDER KINASE ACTIVATOR-LIKE 2C (YEAST)	NM_145279 NM_201403	NP_660322 NP_958805
MPEG1	226818_at	MACROPHAGE EXPRESSED GENE 1	XM_166227	XP_166227
MPEG1	226841_at	MACROPHAGE EXPRESSED GENE 1	XM_166227	XP_166227
MSL3L1	207551_s_at	MALE-SPECIFIC LETHAL 3-LIKE 1 (<i>DROSOPHILA</i>)	NM_006800 NM_078628 NM_078629 NM_078630	NP_006791 NP_523352 NP_523353 NP_523354
MSL3L1	214009_at	MALE-SPECIFIC LETHAL 3-LIKE 1 (<i>DROSOPHILA</i>)	NM_006800 NM_078628 NM_078629 NM_078630	NP_006791 NP_523352 NP_523353 NP_523354
MSRB2	218773_s_at	METHIONINE SULFOXIDE REDUCTASE B2	NM_012228	NP_036360
MTF1	227150_at	METAL-REGULATORY TRANSCRIPTION FACTOR 1	NM_005955	NP_005946
MTMR6	214429_at	MYOTUBULARIN RELATED PROTEIN 6	NM_004685	NP_004676
MYO10	201976_s_at	MYOSIN X	NM_012334	NP_036466
NALP1	210113_s_at	NACHT, LEUCINE RICH REPEAT AND PYD (PYRIN DOMAIN) CONTAINING 1	NM_014922 NM_033004 NM_033006 NM_033007	NP_055737 NP_127497 NP_127499 NP_127500
NALP1	211824_x_at	NACHT, LEUCINE RICH REPEAT AND PYD (PYRIN DOMAIN) CONTAINING 1	NM_014922 NM_033004 NM_033006 NM_033007	NP_055737 NP_127497 NP_127499 NP_127500

TABLE 30-continued

Exemplary biomarkers that discriminate between responders and nonresponders				
Gene Symbol Column 1	Affymetrix Probeset name Column 2	Gene Name Column 3	Gene Accession Number Column 4	Protein Accession Number Column 5
NARF	219862_s_at	NUCLEAR PRELAMIN A RECOGNITION FACTOR	NM_012336 NM_031968	NP_036468 NP_114174
NBS1	202906_s_at	NIJMEGEN BREAKAGE SYNDROME 1 (NIBRIN)	NM_002485	NP_002476
NBS1	217299_s_at	NIJMEGEN BREAKAGE SYNDROME 1 (NIBRIN)	NM_002485	NP_002476
NCR1	207860_at	NATURAL CYTOTOXICITY TRIGGERING RECEPTOR 1	NM_004829	NP_004820
NDST2	203916_at	N-DEACETYLASE/N- SULFOTRANSFERASE (HEPARAN GLUCOSAMINYL) 2	NM_003635	NP_003626
NDUFA1	202298_at	NADH DEHYDROGENASE (UBIQUINONE) 1 ALPHA SUBCOMPLEX, 1, 7.5 KDA	NM_004541	NP_004532
NDUFB3	203371_s_at	NADH DEHYDROGENASE (UBIQUINONE) 1 BETA SUBCOMPLEX, 3, 12 KDA	NM_002491	NP_002482
NFKBIZ	223218_s_at	NUCLEAR FACTOR OF KAPPA LIGHT POLYPEPTIDE GENE ENHANCER IN B-CELLS INHIBITOR, ZETA	NM_001005474 NM_031419	NP_001005474 NP_113607
NMI	203964_at	N-MYC (AND STAT) INTERACTOR	NM_004688	NP_004679
NT5C2	209155_s_at	5'-NUCLEOTIDASE, CYTOSOLIC II	NM_012229	NP_036361
NTNG2	233072_at	NETRIN G2	NM_032536	NP_115925
NUPL1	204435_at	NUCLEOPORIN LIKE 1	NM_001008564 NM_001008565 NM_014089 NM_138799	NP_001008564 NP_001008565 NP_054808 NP_620154
OACT2	226726_at	O-ACYLTRANSFERASE (MEMBRANE BOUND) DOMAIN CONTAINING 2 ORNITHINE AMINOTRANSFERASE (GYRATE ATROPHY)	NM_000274	NP_000265
OAT	201599_at	OLIGODENDROCYTE MYELIN GLYCOPROTEIN	NM_002544	NP_002535
OMG	207093_s_at	5-OXOPROLINASE (ATP- HYDROLYSING)	NM_017570	NP_060040
OPLAH	222025_s_at	PUTATIVE NUCLEAR PROTEIN ORF1-FL49	NM_032412	NP_115788
ORF1-FL49	224707_at	ONCOSTATIN M	NM_020530	NP_065391
OSM	230170_at	ORGANIC SOLUTE TRANSPORTER ALPHA	NM_152672	NP_689885
OSTalpha	229230_at	OTU DOMAIN CONTAINING 1	XM_166659	XP_166659
OTUD1	226140_s_at	PURINERGIC RECEPTOR P2X, LIGAND-GATED ION CHANNEL, 1	NM_002558	NP_002549
P2RX1	210401_at	PHOSPHOPROTEIN ASSOCIATED WITH GLYCOSPHINGOLIPID- ENRICHED MICRODOMAINS	NM_018440	NP_060910
PAG	225622_at	PEPTIDYLGLYCINE ALPHA-AMIDATING MONOOXYGENASE	NM_000919 NM_138766 NM_138821 NM_138822	NP_000910 NP_620121 NP_620176 NP_620177
PAM	202336_s_at	3'-PHOSPHOADENOSINE 5'-PHOSPHOSULFATE SYNTHASE 1	NM_005443	NP_005434
PAPSS1	209043_at	PRE-B-CELL COLONY ENHANCING FACTOR 1	NM_005746 NM_182790	NP_005737 NP_877591
PBEF1	217738_at			

TABLE 30-continued

Exemplary biomarkers that discriminate between responders and nonresponders				
Gene Symbol Column 1	Affymetrix Probeset name Column 2	Gene Name Column 3	Gene Accession Number Column 4	Protein Accession Number Column 5
PBEF1	217739_s_at	PRE-B-CELL COLONY ENHANCING FACTOR 1	NM_005746 NM_182790	NP_005737 NP_877591
PBEF1	1555167_s_at	PRE-B-CELL COLONY ENHANCING FACTOR 1	NM_005746 NM_182790	NP_005737 NP_877591
PBEF1	243296_at	PRE-B-CELL COLONY ENHANCING FACTOR 1	NM_005746 NM_182790	NP_005737 NP_877591
PCGF5	227935_s_at	POLYCOMB GROUP RING FINGER 5	NM_032373	NP_115749
PCMT1	208857_s_at	PROTEIN-L- ISOASPARTATE (D- ASPARTATE) O- METHYLTRANSFERASE	NM_005389	NP_005380
PCMT1	210156_s_at	PROTEIN-L- ISOASPARTATE (D- ASPARTATE) O- METHYLTRANSFERASE	NM_005389	NP_005380
PCMT1	205202_at	PROTEIN-L- ISOASPARTATE (D- ASPARTATE) O- METHYLTRANSFERASE	NM_005389	NP_005380
PDCD1LG1	227458_at	CD274 ANTIGEN (CD274)	NM_014143	NP_054862
PDCD1LG1	223834_at	CD274 ANTIGEN (CD274)	NM_014143	NP_054862
PDE5A	239556_at	PHOSPHODIESTERASE 5A, CGMP-SPECIFIC	NM_001083 NM_033430 NM_033437 NM_033431	NP_001074 NP_236914 NP_246273 NP_237223
PDK1	226452_at	PYRUVATE DEHYDROGENASE KINASE, ISOENZYME 1	NM_002610	NP_002601
PEA15	200788_s_at	PHOSPHOPROTEIN ENRICHED IN ASTROCYTES 15	NM_003768	NP_003759
PFKFB2	209992_at	6-PHOSPHOFRUCTO-2- KINASE/FRUCTOSE-2,6- BIPHOSPHATASE 2	NM_006212	NP_006203
PFKFB2	226733_at	6-PHOSPHOFRUCTO-2- KINASE/FRUCTOSE-2,6- BIPHOSPHATASE 2	NM_006212	NP_006203
PFKFB3	202464_s_at	6-PHOSPHOFRUCTO-2- KINASE/FRUCTOSE-2,6- BIPHOSPHATASE 3	NM_004566	NP_004557
PFTK1	204604_at	PFTAIRE PROTEIN KINASE 1	NM_012395	NP_036527
PGLYRP1	207384_at	PEPTIDOGLYCAN RECOGNITION PROTEIN 1	NM_005091	NP_005082
PGM2	225366_at	PHOSPHOGLUCOMUTASE 2	NM_018290	NP_060760
PGS1	219394_at	PHOSPHATIDYLGLYCERO- PHOSPHATE SYNTHASE	NM_024419	NP_077733
PHTF1	210191_s_at	PUTATIVE HOMEODOMAIN TRANSCRIPTION FACTOR 1	NM_006608	NP_006599
PHTF1	215285_s_at	PUTATIVE HOMEODOMAIN TRANSCRIPTION FACTOR 1	NM_006608	NP_006599
PHTF1	205702_at	PUTATIVE HOMEODOMAIN TRANSCRIPTION FACTOR 1	NM_006608	NP_006599
PIK3AP1	226459_at	PHOSPHOINOSITIDE-3- KINASE ADAPTOR PROTEIN 1	NM_152309	NP_689522
PIK3CB	212688_at	PHOSPHOINOSITIDE-3- KINASE, CATALYTIC, BETA POLYPEPTIDE	NM_006219	NP_006210
PIM3	224739_at	PIM-3 ONCOGENE	NM_001001852	NP_001001852
PIP5K1A	235646_at	PHOSPHATIDYLINOSITOL- 4-PHOSPHATE 5-KINASE, TYPE I, ALPHA	NM_003557	NP_003548

TABLE 30-continued

Exemplary biomarkers that discriminate between responders and nonresponders				
Gene Symbol Column 1	Affymetrix Probeset name Column 2	Gene Name Column 3	Gene Accession Number Column 4	Protein Accession Number Column 5
PLSCR1	244315_at	PHOSPHOLIPID SCRAMBLASE 1	NM_021105	NP_066928
PLSCR1	241916_at	PHOSPHOLIPID SCRAMBLASE 1	NM_021105	NP_066928
POR	208928_at	P450 (CYTOCHROME) OXIDOREDUCTASE	NM_000941	NP_000932
PPP1R12A	201602_s_at	PROTEIN PHOSPHATASE 1, REGULATORY (INHIBITOR) SUBUNIT 12A	NM_002480	NP_002471
PPP4R2	225519_at	PROTEIN PHOSPHATASE 4, REGULATORY SUBUNIT 2	NM_174907	NP_777567
PPP4R2	226317_at	PROTEIN PHOSPHATASE 4, REGULATORY SUBUNIT 2	NM_174907	NP_777567
PRO0149 PRV1	225183_at 219669_at	PRO0149 PROTEIN NEUTROPHIL-SPECIFIC ANTIGEN 1 (POLYCYTHEMIA RUBRA VERA 1)	NM_014117 NM_020406	NP_054836 NP_065139
PSTPIP2	219938_s_at	PROLINE/SERINE/THREONINE PHOSPHATASE- INTERACTING PROTEIN 1 (PROLINE-SERINE- THREONINE PHOSPHATASE INTERACTING PROTEIN 2)	NM_024430	NP_077748
PTDSR	212723_at	CHROMOSOME 17 GENOMIC CONTIG, ALTERNATE ASSEMBLY (PHOSPHATIDYLSERINE RECEPTOR)	NM_015167	NP_055982
PTDSR	212722_s_at	CHROMOSOME 17 GENOMIC CONTIG, ALTERNATE ASSEMBLY (PHOSPHATIDYLSERINE RECEPTOR)	NM_015167	NP_055982
PTGFR	207177_at	CHROMOSOME 17 GENOMIC CONTIG, ALTERNATE ASSEMBLY (PHOSPHATIDYLSERINE RECEPTOR)	NM_015167	NP_055982
PTPN1	202716_at	PROTEIN TYROSINE PHOSPHATASE, NON- RECEPTOR TYPE 1	NM_002827	NP_002818
PTX1	226422_at	PTX1 PROTEIN	NM_016570	NP_057654
QSCN6	201482_at	QUIESCIN Q6	NM_001004128 NM_002826 NM_016131	NP_001004128 NP_002817 NP_057215
RAB10	222981_s_at	RAB10, MEMBER RAS ONCOGENE FAMILY	NM_016131	NP_057215
RAB20	219622_at	RAB20, MEMBER RAS ONCOGENE FAMILY	NM_017817	NP_060287
RAB24	225251_at	RAB24, MEMBER RAS ONCOGENE FAMILY	NM_130781	NP_570137
RAB27A	209514_s_at	RAB27A, MEMBER RAS ONCOGENE FAMILY	NM_004580 NM_183234 NM_183235 NM_183236	NP_004571 NP_899057 NP_899058 NP_899059
RAB27A	210951_x_at	RAB27A, MEMBER RAS ONCOGENE FAMILY	NM_004580 NM_183234 NM_183235 NM_183236 NM_198490	NP_004571 NP_899057 NP_899058 NP_899059 NP_940892
RAB43	225632_s_at	RAB43, MEMBER RAS ONCOGENE FAMILY	NM_198490	NP_940892
RAB8B	219210_s_at	RAB8B, MEMBER RAS ONCOGENE FAMILY	NM_016530	NP_057614
RABGEF1	218310_at	RAB GUANINE NUCLEOTIDE EXCHANGE	NM_014504	NP_055319

TABLE 30-continued

Exemplary biomarkers that discriminate between responders and nonresponders				
Gene Symbol Column 1	Affymetrix Probeset name Column 2	Gene Name Column 3	Gene Accession Number Column 4	Protein Accession Number Column 5
		FACTOR (RAB GUANINE NUCLEOTIDE EXCHANGE FACTOR (GEF) 1)		
RAD23B	201222_s_at	RAD23 HOMOLOG B (<i>S. CEREVISIAE</i>)	NM_002874	NP_002865
RALB	202101_s_at	V-RAL SIMIAN LEUKEMIA VIRAL ONCOGENE HOMOLOG B (RAS RELATED; GTP BINDING PROTEIN)	NM_002881	NP_002872
RAPGEFL1	218657_at	RAP GUANINE NUCLEOTIDE EXCHANGE FACTOR (GEF)-LIKE 1	NM_014504	NP_055319
RARA	228037_at	RETINOIC ACID RECEPTOR, ALPHA	NM_000964	NP_000955
RASSF4	226436_at	RAS ASSOCIATION (RALGDS/AF-6) DOMAIN FAMILY 4	NM_032023 NM_178145	NP_114412 NP_835281
RB1CC1	202033_s_at	RB1-INDUCIBLE COILED- COIL 1	NM_014781	NP_055596
RBMS1	225265_at	RNA BINDING MOTIF, SINGLE STRANDED INTERACTING PROTEIN 1	NM_002897 NM_016836 NM_016839	NP_002888 NP_058520 NP_058523
RBMS1	238317_x_at	RNA BINDING MOTIF, SINGLE STRANDED INTERACTING PROTEIN 1	NM_002897 NM_016836 NM_016839	NP_002888 NP_058520 NP_058523
RFWD2	234950_s_at	RING FINGER AND WD REPEAT DOMAIN 2	NM_001001740 NM_022457	NP_001001740 NP_071902
Rgr	235816_s_at	RAL-GDS RELATED PROTEIN RGR	NM_153615	NP_705843
RGS10	204319_s_at	REGULATOR OF G- PROTEIN SIGNALLING 10	NM_001005339 NM_002925	NP_001005339 NP_002916
RHOT1	222148_s_at	RAS HOMOLOG GENE FAMILY, MEMBER T1	NM_018307	NP_060777
RIT1	209882_at	RAS-LIKE WITHOUT CAAX 1	NM_006912	NP_008843
RNASE6	213566_at	RIBONUCLEASE, RNASE A FAMILY, K6	NM_005615	NP_005606
RNASEL	229285_at	RIBONUCLEASE L (2',5'- OLIGOISADENYLATE SYNTHETASE- DEPENDENT)	NM_021133	NP_066956
RNF13	201779_s_at	RING FINGER PROTEIN 13	NM_007282 NM_183381 NM_183382 NM_183383 NM_183384	NP_009213 NP_899237 NP_899238 NP_899239 NP_899240
RNF13	201780_s_at	RING FINGER PROTEIN 13	NM_007282 NM_183381 NM_183382 NM_183383 NM_183384	NP_009213 NP_899237 NP_899238 NP_899239 NP_899240
ROD1	224618_at	ROD1 REGULATOR OF DIFFERENTIATION 1 (<i>S. POMBE</i>)	NM_005156	NP_005147
ROD1	214697_s_at	ROD1 REGULATOR OF DIFFERENTIATION 1 (<i>S. POMBE</i>)	NM_005156	NP_005147
RRM2	209773_s_at	RIBONUCLEOTIDE REDUCTASE M2 POLYPEPTIDE	NM_001034	NP_001025
RSBN1	213694_at	ROUND SPERMATID BASIC PROTEIN 1	NM_018364	NP_060834
RTN1	203485_at	RETICULON 1	NM_021136 NM_206852 NM_206857	NP_066959 NP_996734 NP_996739
RTN4	214629_x_at	RETICULON 4	NM_007008 NM_020532 NM_153828	NP_008939 NP_065393 NP_722550

TABLE 30-continued

Exemplary biomarkers that discriminate between responders and nonresponders				
Gene Symbol Column 1	Affymetrix Probeset name Column 2	Gene Name Column 3	Gene Accession Number Column 4	Protein Accession Number Column 5
			NM_207520	NP_997403
			NM_207521	NP_997404
RY1	212438_at	PUTATIVE NUCLEIC ACID BINDING PROTEIN RY-1	NM_006857	NP_006848
S100A12	205863_at	S100 CALCIUM BINDING PROTEIN A12	NM_005621	NP_005612
SAMSN1	1555638_a_at	(CALGRANULIN C) SAM DOMAIN, SH3 DOMAIN, AND NUCLEAR LOCALIZATION SIGNALS, 1	NM_022136	NP_071419
SAMSN1	220330_s_at	SAM DOMAIN, SH3 DOMAIN, AND NUCLEAR LOCALIZATION SIGNALS, 1	NM_022136	NP_071419
SAP30L	219129_s_at	SIN3A ASSOCIATED PROTEIN P30-LIKE	NM_024632	NP_078908
SART2	218854_at	SQUAMOUS CELL CARCINOMA ANTIGEN RECOGNIZED BY T CELLS 2	NM_013352	NP_037484
SBNO1	218737_at	SNO, STRAWBERRY NOTCH HOMOLOG 1 (<i>DROSOPHILA</i>)	NM_018183	NP_060653
SDF2	203090_at	STROMAL CELL-DERIVED FACTOR 2	NM_006923	NP_008854
SDHC	238056_at	SUCCINATE DEHYDROGENASE COMPLEX, SUBUNIT C, INTEGRAL MEMBRANE PROTEIN, 15 KDA	NM_003001	NP_002992
SEC15L1	226259_at	SEC15-LIKE 1 (<i>S. CEREVISIAE</i>)	NM_019053	NP_061926
			NM_001013848	NP_001013870
SEC15L1	233924_s_at	SEC15-LIKE 1 (<i>S. CEREVISIAE</i>)	NM_019053	NP_061926
			NM_001013848	NP_001013870
SEC24A	212902_at	SEC24 RELATED GENE FAMILY, MEMBER A (<i>S. CEREVISIAE</i>)	XM_094581	XP_094581
SEL1L	202064_s_at	SEL-1 SUPPRESSOR OF LIN-12-LIKE (<i>C. ELEGANS</i>)	NM_005065	NP_005056
SERPINB1	228726_at	SERINE (OR CYSTEINE) PROTEINASE INHIBITOR, CLADE B (OVALBUMIN), MEMBER 1	NM_030666	NP_109591
SERPINB1	212268_at	SERINE (OR CYSTEINE) PROTEINASE INHIBITOR, CLADE B (OVALBUMIN), MEMBER 1	NM_030666	NP_109591
SF3B14	223416_at	SPLICING FACTOR 3B, 14 KDA SUBUNIT	NM_016047	NP_057131
SH3GLB1	209091_s_at	SH3-DOMAIN GRB2-LIKE ENDOPHILIN B1	NM_016009	NP_057093
SH3GLB1	210101_x_at	SH3-DOMAIN GRB2-LIKE ENDOPHILIN B1	NM_016009	NP_057093
SIPA1L2	225056_at	SIGNAL-INDUCED PROLIFERATION- ASSOCIATED GENE 1 (SIGNAL-INDUCED PROLIFERATION- ASSOCIATED 1 LIKE 2)	NM_020808	NP_065859
SLA	203761_at	SRC-LIKE-ADAPTOR	NM_006748	NP_006739
SLA	244492_at	SRC-LIKE-ADAPTOR	NM_006748	NP_006739
SLC22A4	205896_at	SOLUTE CARRIER FAMILY 22 (ORGANIC CATION TRANSPORTER), MEMBER 4	NM_003059	NP_003050
SLC25A28	221432_s_at	SOLUTE CARRIER FAMILY 25, MEMBER 28	NM_031212	NP_112489
SLC26A8	237340_at	SOLUTE CARRIER FAMILY 26, MEMBER 8	NM_052961	NP_443193
			NM_138718	NP_619732

TABLE 30-continued

Exemplary biomarkers that discriminate between responders and nonresponders				
Gene Symbol Column 1	Affymetrix Probeset name Column 2	Gene Name Column 3	Gene Accession Number Column 4	Protein Accession Number Column 5
SLC2A3	202497_x_at	SOLUTE CARRIER FAMILY 2 (FACILITATED GLUCOSE TRANSPORTER), MEMBER 3	NM_006931	NP_008862
SLC2A3	202498_s_at	SOLUTE CARRIER FAMILY 2 (FACILITATED GLUCOSE TRANSPORTER), MEMBER 3	NM_006931	NP_008862
SLC2A3	216236_s_at	SOLUTE CARRIER FAMILY 2 (FACILITATED GLUCOSE TRANSPORTER), MEMBER 3	NM_006931	NP_008862
SLC2A3	202499_s_at	SOLUTE CARRIER FAMILY 2 (FACILITATED GLUCOSE TRANSPORTER), MEMBER 3	NM_006931	NP_008862
SLC2A3	222088_s_at	SOLUTE CARRIER FAMILY 2 (FACILITATED GLUCOSE TRANSPORTER), MEMBER 3	NM_006931	NP_008862
SLC2A3	236571_at	SOLUTE CARRIER FAMILY 2 (FACILITATED GLUCOSE TRANSPORTER), MEMBER 3	NM_006931	NP_008862
SLC37A3	223304_at	SOLUTE CARRIER FAMILY 37 (GLYCEROL-3- PHOSPHATE TRANSPORTER), MEMBER 3	NM_032295 NM_207113	NP_115671 NP_996996
SLC38A2	220924_s_at	SOLUTE CARRIER FAMILY 38, MEMBER 2	NM_018976	NP_061849
SMPDL3A	213624_at	SPHINGOMYELIN PHOSPHODIESTERASE, ACID-LIKE 3A	NM_006714	NP_006705
SOCS3	227697_at	SUPPRESSOR OF CYTOKINE SIGNALING 3	NM_003955	NP_003946
SOCS3	206359_at	SUPPRESSOR OF CYTOKINE SIGNALING 3	NM_003955	NP_003946
SOD2	216841_s_at	SUPEROXIDE DISMUTASE 2, MITOCHONDRIAL	NM_000636	NP_000627
SP100	202863_at	NUCLEAR ANTIGEN SP100	NM_003113	NP_003104
SPPL2A	226353_at	SIGNAL PEPTIDE PEPTIDASE-LIKE 2A	NM_032802	NP_116191
SQRDL	217995_at	SULFIDE QUINONE REDUCTASE-LIKE (YEAST)	NM_021199	NP_067022
SRPK1	202200_s_at	PROTEIN KINASE, SERINE/ARGININE- SPECIFIC, 1 (SFRS PROTEIN KINASE 1)	NM_003137	NP_003128
ST3GAL4	203759_at	ST3 BETA-GALACTOSIDE ALPHA-2,3- SIALYLTRANSFERASE 4	NM_006278	NP_006269
ST6GALNAC4	223285_s_at	ST6 (ALPHA-N-ACETYL- NEURAMINYL-2,3-BETA- GALACTOSYL-1,3)-N- ACETYLGALACTOSAMINIDE ALPHA-2,6- SIALYLTRANSFERASE 4	NM_014403 NM_175039 NM_175040	NP_055218 NP_778204 NP_778205
STAT5B	1555086_at	SIGNAL TRANSDUCER AND ACTIVATOR OF TRANSCRIPTION 5B	NM_012448	NP_036580
STK17B	205214_at	SERINE/THREONINE KINASE 17B (APOPTOSIS- INDUCING)	NM_004226	NP_004217
STK3	204068_at	SERINE/THREONINE PROTEIN KINASE 3 (SERINE/THREONINE	NM_006281	NP_006272

TABLE 30-continued

Exemplary biomarkers that discriminate between responders and nonresponders				
Gene Symbol Column 1	Affymetrix Probeset name Column 2	Gene Name Column 3	Gene Accession Number Column 4	Protein Accession Number Column 5
STOM	201060_x_at	KINASE 3 (STE20 HOMOLOG, YEAST) STOMATIN	NM_004099 NM_198194	NP_004090 NP_937837
STX3A	209238_at	SYNTAXIN 3A	NM_004177	NP_004168
SULF2	233555_s_at	SULFATASE 2	NM_018837	NP_061325
SULF2	224724_at	SULFATASE 2	NM_198596 NM_018837	NP_940998 NP_061325
SULT1A1	203615_x_at	SULFOTRANSFERASE FAMILY, CYTOSOLIC, 1A, PHENOL-PREFERRING, MEMBER 1	NM_198596 NM_001055 NM_177529 NM_177530 NM_177534 NM_177536	NP_940998 NP_001046 NP_803565 NP_803566 NP_803878 NP_803880
SULT1B1	207601_at	SULFOTRANSFERASE FAMILY, CYTOSOLIC, 1B, MEMBER 1	NM_014465	NP_055280
TBC1D15	218268_at	TBC1 DOMAIN FAMILY, MEMBER 15	NM_022771	NP_073608
TBC1D8	204526_s_at	TBC1 DOMAIN FAMILY, MEMBER 8 (WITH GRAM DOMAIN)	NM_007063	NP_008994
TCTEL1	201999_s_at	T-COMPLEX- ASSOCIATED-TESTIS- EXPRESSED 1 (T- COMPLEX-ASSOCIATED- TESTIS-EXPRESSED 1- LIKE 1	NM_006519	NP_006510
TCTEL1	242109_at	T-COMPLEX- ASSOCIATED-TESTIS- EXPRESSED 1 (T- COMPLEX-ASSOCIATED- TESTIS-EXPRESSED 1- LIKE 1	NM_006519	NP_006510
TDRD9	228285_at	TUDOR DOMAIN CONTAINING 9	NM_153046	NP_694591
TGFBI	201506_at	TRANSFORMING GROWTH FACTOR, BETA- 1 (TRANSFORMING GROWTH FACTOR, BETA- INDUCED, 68 KDA)	NM_000358	NP_000349
TIAM2	222942_s_at	T-CELL LYMPHOMA INVASION AND METASTASIS 2	NM_001010927 NM_012454	NP_001010927 NP_036586
TIFA	238858_at	TRAF-INTERACTING PROTEIN WITH A FORKHEAD-ASSOCIATED DOMAIN	NM_052864	NP_443096
TIFA	226117_at	TRAF-INTERACTING PROTEIN WITH A FORKHEAD-ASSOCIATED DOMAIN	NM_052864	NP_443096
TIFA	235971_at	TRAF-INTERACTING PROTEIN WITH A FORKHEAD-ASSOCIATED DOMAIN	NM_052864	NP_443096
TLR5	210166_at	TOLL-LIKE RECEPTOR 5	NM_003268	NP_003259
TMEM2	218113_at	TRANSMEMBRANE PROTEIN 2	NM_013390	NP_037522
TMEM33	235907_at	TRANSMEMBRANE PROTEIN 33	NM_018126	NP_060596
TMOD3	223078_s_at	TROPOMODULIN 3 (UBIQUITOUS)	NM_014547	NP_055362
TncRNA	214657_s_at	TROPHOBLAST-DERIVED NONCODING RNA		

TABLE 30-continued

Exemplary biomarkers that discriminate between responders and nonresponders				
Gene Symbol Column 1	Affymetrix Probeset name Column 2	Gene Name Column 3	Gene Accession Number Column 4	Protein Accession Number Column 5
TNFAIP6	206026_s_at	TUMOR NECROSIS FACTOR, ALPHA- INDUCED PROTEIN 6	NM_007115	NP_009046
TNFAIP6	206025_s_at	TUMOR NECROSIS FACTOR, ALPHA- INDUCED PROTEIN 6	NM_007115	NP_009046
TNFAIP9	225987_at	TUMOR NECROSIS FACTOR, ALPHA- INDUCED PROTEIN 9	NM_024636	NP_078912
TNFSF10	202687_s_at	TUMOR NECROSIS FACTOR (LIGAND) SUPERFAMILY, MEMBER 10	NM_003810	NP_003801
TNFSF13B	223501_at	TUMOR NECROSIS FACTOR (LIGAND) SUPERFAMILY, MEMBER 13B	NM_006573	NP_006564
TOP1	208901_s_at	TOPOISOMERASE (DNA) I	NM_003286	NP_003277
TOSO	221602_s_at	FAS APOPTOTIC INHIBITORY MOLECULE (FAIM3)	NM_005449	NP_005440
TPARL	218095_s_at	TPA REGULATED LOCUS	NM_018475	NP_060945
TPCN1	242108_at	TWO PORE SEGMENT CHANNEL 1	NM_017901	NP_060371
TPRT	220865_s_at	TRANS- PRENYLTRANSFERASE	NM_014317	NP_055132
TRA@	234013_at	T CELL RECEPTOR ALPHA LOCUS		
TRA@	211902_x_at	T CELL RECEPTOR ALPHA LOCUS		
TRBC1	211796_s_at	T CELL RECEPTOR BETA CONSTANT 1		
TRIB1	202241_at	TRIBBLES HOMOLOG 1 (<i>DROSOPHILA</i>)	NM_025195	NP_079471
TRPM6	224412_s_at	TRANSIENT RECEPTOR POTENTIAL CATION CHANNEL, SUBFAMILY M, MEMBER 6	NM_017662	NP_060132
TTN	240793_at	TITIN	NM_003319 NM_133378 NM_133379 NM_133432 NM_133437	NP_003310 NP_596869 NP_596870 NP_597676 NP_597681
TTYH2	223741_s_at	TWEETY, <i>DROSOPHILA</i> , HOMOLOG OF, 2	NM_032646 NM_052869	NP_116035 NP_443101
TXN	208864_s_at	THIOREDOXIN	NM_003329	NP_003320
UBE2H	222421_at	UBIQUITIN- CONJUGATING ENZYME E2H (UBC8 HOMOLOG, YEAST)	NM_003344 NM_182697	NP_003335 NP_874356
UBE2J1	217826_s_at	UBIQUITIN- CONJUGATING ENZYME E2, J1 (UBC6 HOMOLOG, YEAST)	NM_016021	NP_057105
UBQLN2	215884_s_at	UBIQUILIN 2	NM_013444	NP_038472
UNC84B	229548_at	UNC-84 HOMOLOG B (<i>C. ELEGANS</i>)	NM_015374	NP_056189
USP38	223289_s_at	UBIQUITIN SPECIFIC PROTEASE 38	NM_032557	NP_115946
USP9X	201099_at	UBIQUITIN SPECIFIC PROTEASE 9, X-LINKED (FAT FACETS-LIKE, <i>DROSOPHILA</i>)	NM_004652 NM_021906	NP_004643 NP_068706
VAV3	218807_at	VAV 3 ONCOGENE	NM_006113	NP_006104
WBP4	203598_s_at	WW DOMAIN BINDING PROTEIN 4 (FORMIN BINDING PROTEIN 21)	NM_007187	NP_009118

TABLE 30-continued

Exemplary biomarkers that discriminate between responders and nonresponders				
Gene Symbol Column 1	Affymetrix Probeset name Column 2	Gene Name Column 3	Gene Accession Number Column 4	Protein Accession Number Column 5
WDFY3	212606_at	WD REPEAT AND FYVE DOMAIN CONTAINING 3	NM_014991 NM_178583 NM_178585	NP_055806 NP_848698 NP_848700
WDFY3	212602_at	WD REPEAT AND FYVE DOMAIN CONTAINING 3	NM_014991 NM_178583 NM_178585	NP_055806 NP_848698 NP_848700
WDFY3	212598_at	WD REPEAT AND FYVE DOMAIN CONTAINING 3	NM_014991 NM_178583 NM_178585	NP_055806 NP_848698 NP_848700
WSB1	227501_at	WD REPEAT AND SOCS BOX-CONTAINING 1	NM_015626 NM_134264 NM_134265	NP_056441 NP_599026 NP_599027
WSB1	210561_s_at	WD REPEAT AND SOCS BOX-CONTAINING 1	NM_015626 NM_134264 NM_134265	NP_056441 NP_599026 NP_599027
WSB1	201296_s_at	WD REPEAT AND SOCS BOX-CONTAINING 1	NM_015626 NM_134264 NM_134265	NP_056441 NP_599026 NP_599027
XRN1	1555785_a_at	5'-3' EXORIBONUCLEASE 1	NM_019001	NP_061874
XRN1	233632_s_at	5'-3' EXORIBONUCLEASE 1	NM_019001	NP_061874
ZC3HAV1	225634_at	ZINC FINGER CCHH TYPE, ANTIVIRAL 1	NM_020119 NM_024625	NP_064504 NP_078901
ZCSL2	225195_at	ZINC FINGER, CSL DOMAIN CONTAINING 2	NM_206831	NP_996662
ZDHHC19	231122_x_at	ZINC FINGER, DHHC DOMAIN CONTAINING 19	NM_144637	NP_653238
ZDHHC19	1553952_at	ZINC FINGER, DHHC DOMAIN CONTAINING 19	NM_144637	NP_653238
ZFP276	213778_x_at	ZINC FINGER PROTEIN 276 HOMOLOG (MOUSE)	NM_152287	NP_689500
ZFP36L2	201367_s_at	ZINC FINGER PROTEIN 36, C3H TYPE-LIKE 2; ZFP36L2	NM_006887	NP_008818
ZFP36L2	201369_s_at	ZINC FINGER PROTEIN 36, C3H TYPE-LIKE 2; ZFP36L2	NM_006887	NP_008818
ZNF167	206314_at	ZINC FINGER PROTEIN 167	NM_018651 NM_025169	NP_061121 NP_079445
	230585_at	EST		
	200880_at	EST		
	230267_at	EST		
	215966_x_at	EST		
	237071_at	EST		
	230683_at	EST		
	241388_at	EST		
	204166_at	EST		
	241652_x_at	EST		
	229968_at	EST		
	223596_at	EST		
	240310_at	EST		
	216609_at	EST		
	224604_at	EST		
	223797_at	EST		
	238973_s_at	EST		
	230632_at	EST		
	230575_at	EST		
	1559777_at	EST		
	244313_at	EST		
	242582_at	EST		
	233264_at	EST		
	219253_at	EST		
	235427_at	EST		
	1555311_at	EST		
	229934_at	EST		
	231035_s_at	EST		
	230999_at	EST		
	224261_at	EST		
	239780_at	EST		
	239669_at	EST		

TABLE 30-continued

Exemplary biomarkers that discriminate between responders and nonresponders				
Gene Symbol Column 1	Affymetrix Probeset name Column 2	Gene Name Column 3	Gene Accession Number Column 4	Protein Accession Number Column 5
	213002_at	EST		
	227925_at	EST		
	235456_at	EST		
	233312_at	EST		
	239167_at	EST		
	1569263_at	EST		
	216198_at	EST		
	232876_at	EST		
	237387_at	EST		
	216621_at	EST		
	235352_at	EST		
	1564933_at	EST		
	222376_at	EST		
	205922_at	EST		
	1557626_at	EST		
	228758_at	EST		
	1557733_a_at	EST		
	236898_at	EST		

[0526] Each of the sequences, genes, proteins, and probesets identified in Table 30 is hereby incorporated by reference.

6.7 Exemplary Biomarker Combinations

[0527] In one embodiment of the present invention, an additional criterion was applied to the set of biomarkers identified in Section 6.6. Specifically, the additional criterion that was imposed was a requirement that each respective biomarker under consideration exhibit at least a 1.2× fold change between the median value for the respective biomarker among the subjects that acquired sepsis during a defined time period (sepsis subjects) and the median value for the respective biomarker among subjects that do not acquire sepsis during the defined time period (SIRS subjects) at the T_{-12} static time and at the T_{-36} static time periods. Furthermore, to satisfy the third criterion, the biomarker must have been used in at least one multivariate analysis with significant classification performance where significant classification performance is defined by having a lower 95th percentile for accuracy on a training data set that is greater than 50% and a point estimate for accuracy on the validation set that is greater than 65% at any time point measured. As noted in FIG. 30, application of this third filter criterion reduced the number of eligible biomarkers from 626 to 130. These biomarkers are listed column two of Table 31. In column two of Table 31, the biomarkers are indicated by the U133 plus 2.0 probeset to which they bind. However, in some embodiments, each such biomarker is, in fact, an mRNA, cDNA, or other such nucleic acid molecule corresponding to the identified U133 plus 2.0 oligonucleotide probe listed in column two of Table 31.

[0528] In column one of Table 31, each biomarker is listed by a gene name, such as, for example, a Human Gene Nomenclature Database (HUGO) symbol set forth by the Gene Nomenclature Committee, Department of Biology, University College London. As is known in the art, some human genome genes are represented by more than one probeset in

the U133 plus 2.0 array. Furthermore, some of the oligonucleotides in the U133 plus 2.0 array represent expression sequence tags (ESTs) that do not correspond to a known gene. As a result, the 130 biomarkers listed in Table 31, in fact, represent 95 different known genes (see FIG. 30). Where known, the names of the 95 different human genes are listed in column three of Table 31.

[0529] In column four of Table 31, the median fold change between the mean value of the biomarker measured from T_{-12} samples of those subjects in the training population that develop sepsis (sepsis subjects) versus the mean value of the biomarker measured from T_{-12} samples of those subjects in the training population that do not develop sepsis (SIRS subjects) is given. In column five of Table 31, the direction of the fold change, where “+” indicates that the mean value in the sepsis subjects is greater than in the SIRS subjects, is given.

[0530] In column six of Table 31, the median fold change between the mean value of the biomarker measured from T_{-36} samples of those subjects in the training population that develop sepsis (sepsis subjects) versus the mean value of the biomarker measured from T_{-36} samples of those subjects in the training population that do not develop sepsis (SIRS subjects) is given. In column seven of Table 31, the direction of the fold change, where “+” indicates that the mean value in the sepsis subjects is greater than in the SIRS subjects, is given.

[0531] In a particular embodiment, the biomarker profile comprises at least two different biomarkers that each contain one of the probesets of Table 32, biomarkers that contain the complement of one of the probesets of Table 32, or biomarkers that contain an amino acid sequence encoded by a gene that contains one of the probesets of Table 32. Such biomarkers can be, for example, mRNA transcripts, cDNA or some other nucleic acid, for example amplified nucleic acid, or proteins. The biomarker profile further comprises a respective corresponding feature for the at least two biomarkers. Generally, the at least two biomarkers are derived from at least

two different genes. In the case where a biomarker is based upon a gene that includes the sequence of a probeset listed in Table 32 or a complement thereof, the biomarker can be, for example, a transcript made by the gene, a complement thereof, or a discriminating fragment or complement thereof, or a cDNA thereof, or a discriminating fragment of the cDNA, or a discriminating amplified nucleic acid molecule corresponding to all or a portion of the transcript or its complement, or a protein encoded by the gene, or a discriminating fragment of the protein, or an indication of any of the above. Further still, the biomarker can be, for example, a protein encoded by a gene that includes a probeset sequence described in Table 32 or a discriminating fragment of the protein, or an indication of the above. Here, a discriminating molecule or fragment is a molecule or fragment that, when detected, indicates presence or abundance of the above-identified transcript, cDNA, amplified nucleic acid, or protein. In one embodiment, a biomarker profile of the present invention

comprises a plurality of biomarkers that contain at least five, at least ten at least fifteen, at least twenty, at least thirty, between 2 and 5, between 3 and 7, or less than 15 of the sequences of the probesets of Table 32, or complements thereof, or genes including one of at least five of the sequences or complements thereof, or a discriminating fragment thereof, or an amino acid sequence encoded by any of the foregoing nucleic acid sequences, or any discriminating fragment of such an amino acid sequence. Such biomarkers can be, for example, mRNA transcripts, cDNA or some other nucleic acid, for example amplified nucleic acid, or proteins. In some embodiments a biomarker is any gene that includes the sequence in an Affymetrix probeset given in Table 31, or any gene that includes a complement of the sequence in an Affymetrix probeset given in Table 32, or any mRNA, cDNA or other form of amplified nucleic acid of the foregoing, for any discriminating fragment of the foregoing, or any amino acid sequence coded by the foregoing, or any discriminating fragment of such a protein.

TABLE 31

Exemplary biomarkers that discriminate between converters and non-converters						
Gene Symbol Column 1	Affymetrix Probeset name Column 2	Gene Name Column 3	T ₁₂ Values		T ₃₆ Values	
			Median FC Column 3	Direction Column 4	Median FC Column 5	Direction Column 6
	1555785_a_at	EST	1.34	Up	1.31	up
	227150_at	EST	1.45	Up	1.34	up
	238973_s_at	EST	1.33	Up	1.25	up
	239893_at	EST	1.89	Up	1.46	up
	237563_s_at	EST	1.84	Up	1.60	up
	244313_at	EST	1.87	Up	1.80	up
	237071_at	EST	1.73	up	1.37	up
	229934_at	EST	1.67	up	1.41	up
	1555311_at	EST	1.31	up	1.21	up
	233264_at	EST	1.52	up	1.36	up
	239780_at	EST	1.93	up	1.42	up
	238405_at	EST	3.02	up	2.23	up
3'HEXO	226416_at	HISTONE MRNA 3' END EXORIBONUCLEASE	1.70	up	1.41	up
3'HEXO	231852_at		1.45	up	1.22	up
ADORA2A	205013_s_at	ADENOSINE A2 RECEPTOR	1.32	up	1.33	up
ANXA3	209369_at	ANNEXIN A3	2.82	up	2.23	up
ASAH1	214765_s_at	N-ACYLSPHINGOSINE AMIDOHYDROLASE-LIKE PROTEIN	1.28	down	1.29	down
ASAH1	232072_at		1.23	down	1.31	down
ASAH1	227135_at		1.24	down	1.26	down
ATP11B	1554557_at	ATPASE, CLASS VI, TYPE 11B	1.70	up	1.49	up
ATP6V1C1	202872_at	ATPASE, H+ TRANSPORTING, LYSOSOMAL, 42-KD, V1 SUBUNIT C, ISOFORM 1	1.85	up	1.49	up
B4GALT5	221485_at	BETA-1,4- GALACTOSYLTRANSFERASE	1.67	up	1.43	up
BASP1	202391_at	BRAIN-ABUNDANT SIGNAL PROTEIN	1.42	up	1.23	up
BAZ1A	217986_s_at	BROMODOMAIN ADJACENT TO ZINC FINGER DOMAIN, 1A	1.89	up	1.57	up
BCL6	203140_at	B-CELL LYMPHOMA 6	1.46	up	1.33	up
BMX	206464_at	BONE MARROW KINASE, X- LINKED	1.87	up	1.52	up
C16orf7	205781_at	CHROMOSOME 16 OPEN- READING FRAME 7	1.96	up	1.49	up
C20orf32	1554786_at	CHROMOSOME 20 OPEN- READING FRAME 32	1.27	down	1.24	down
C3F	203547_at	COMPLEMENT COMPONENT 3	1.28	down	1.26	down
C8FW	202241_at	C8FW GENE; PHOSPHOPROTEIN.	1.57	up	1.34	up

TABLE 31-continued

Exemplary biomarkers that discriminate between converters and non-converters						
Gene Symbol Column 1	Affymetrix Probeset name Column 2	Gene Name Column 3	T ₁₇ Values		T ₃₆ Values	
			Median FC Column 3	Direction Column 4	Median FC Column 5	Direction Column 6
CEACAM1	209498_at	CARCINOEMBRYONIC ANTIGEN-RELATED CELL ADHESION MOLECULE 1	2.78	up	2.20	up
CEACAM1	211883_x_at		1.87	up	1.61	up
CECR1	219505_at	CAT EYE SYNDROME CHROMOSOME REGION, CANDIDATE 1	1.25	down	1.26	down
CHCHD7	222701_s_at	COILED-COIL-HELIX DOMAIN-CONTAINING PROTEIN 7	1.58	up	1.26	up
CHSY1	203044_at	CARBOHYDRATE SYNTHASE 1	1.78	up	1.24	up
CKLF	223451_s_at	CHEMOKINE-LIKE FACTOR	1.59	up	1.40	up
CKLF	219161_s_at		1.38	up	1.31	up
CL25022	217883_at		1.36	up	1.31	up
CPD	201940_at	CARBOXYPEPTIDASE D	1.61	up	1.38	up
CPD	201941_at		1.61	up	1.35	up
CRTAP	1554464_a_at	CARTILAGE-ASSOCIATED PROTEIN	1.23	down	1.21	down
DHRS9	219799_s_at	MEMBRANE PROTEIN, PALMITOYLATED 3; MPP3	1.94	up	1.52	up
EIF4G3	201936_s_at	EUKARYOTIC TRANSLATION INITIATION FACTOR 4-GAMMA, 3	1.58	up	1.28	up
FAD104	218618_s_at	FIBRONECTIN TYPE III	1.61	up	1.38	up
FAD104	225032_at	DOMAIN CONTAINING 3B	1.63	up	1.41	up
FAD104	222692_s_at	(FNDC3B	1.74	up	1.59	up
FAD104	222693_at		1.88	up	1.92	up
FCGR1A	214511_x_at	FC FRAGMENT OF IGG, HIGH	2.37	up	1.71	up
FCGR1A	216950_s_at	AFFINITY IA	2.56	up	1.60	up
FLJ11175	229005_at		1.77	up	1.50	up
FLJ11175	220603_s_at		2.12	up	1.77	up
FLJ11259	218627_at		1.54	up	1.25	up
FLJ11795	220112_at		1.80	up	1.62	up
FLJ22833	219334_s_at		1.49	up	1.28	up
G0S2	213524_s_at		1.69	up	1.30	up
GADD45B	207574_s_at	GROWTH ARREST- AND DNA DAMAGE-INDUCIBLE GENE GADD45	1.55	up	1.37	up
GADD45B	209304_x_at		1.42	up	1.25	up
GK	214681_at	GLYCEROL KINASE	1.76	up	1.39	up
GPR160	223423_at	G PROTEIN-COUPLED RECEPTOR 160	1.83	up	1.54	up
HLA-DMA	217478_s_at	HLA-D HISTOCOMPATIBILITY TYPE	1.32	down	1.27	down
HLA-DMB	203932_at		1.29	down	1.27	down
HLA-DPA1	211991_s_at		1.34	down	1.27	down
HLA-DQB1	209823_x_at		1.31	down	1.20	down
HLA-DRA	210982_s_at		1.25	down	1.24	down
HLA-DRA	208894_at		1.29	down	1.23	down
HLA-DRB1	215193_x_at		1.30	down	1.30	down
HLA-DRB1	209312_x_at		1.27	down	1.30	down
HLA-DRB4	204670_x_at		1.25	down	1.27	down
HLA-DRB4	208306_x_at		1.27	down	1.27	down
HPGD	203913_s_at	15- HYDROXYPROSTAGLANDIN DEHYDROGENASE	2.01	up	1.57	up
HRPT2	218578_at	HYPERPARATHYROIDISM 2	1.43	up	1.27	up
HSPC163	228437_at	HSPC163 PROTEIN	1.64	up	1.46	up
HSPC163	218728_s_at		2.00	up	1.52	up
IDI1	204615_x_at	ISOPENTENYL- DIPHOSPHATE DELTA- ISOMERASE	1.51	up	1.31	up
IL18R1	206618_at	INTERLEUKIN 18 RECEPTOR 1	3.18	up	2.37	up
KCNE1	236407_at	POTASSIUM CHANNEL, VOLTAGE-GATED, ISK- RELATED SUBFAMILY	1.68	up	1.45	up

TABLE 31-continued

Exemplary biomarkers that discriminate between converters and non-converters						
Gene Symbol Column 1	Affymetrix Probeset name Column 2	Gene Name Column 3	T ₁₇ Values		T ₃₆ Values	
			Median FC Column 3	Direction Column 4	Median FC Column 5	Direction Column 6
KIF1B	225878_at	KINESIN FAMILY MEMBER 1B;	2.04	up	1.62	up
KREMEN1	227250_at	KRINGLE CONTAINING TRANSMEMBRANE PROTEIN 1	2.11	up	1.32	up
LDLR	202068_s_at	LOW DENSITY LIPOPROTEIN RECEPTOR	1.55	up	1.52	up
LIMK2	202193_at	LIM DOMAIN KINASE 2	2.05	up	1.51	up
LOC199675	235568_at		2.91	up	2.03	up
LOC284829	225669_at		1.48	up	1.30	up
LOC285771	237870_at		1.40	up	1.34	up
LRG1	228648_at	LEUCINE-RICH ALPHA-2- GLYCOPROTEIN 1	2.08	up	1.62	up
MGC22805	239196_at	NOVEL GENE (MGC22805),	2.30	up	1.86	up
MGC22805	238439_at		3.38	up	2.24	up
MPEG1	226841_at	MACROPHAGE EXPRESSED GENE 1	1.23	down	1.21	down
OAT	201599_at	ORNITHINE AMINOTRANSFERASE DEFICIENCY	1.53	up	1.44	up
ORF1-FL49	224707_at		1.75	up	1.65	up
PDCD1LG1	227458_at	PROGRAMMED CELL DEATH 1 LIGAND 1	2.22	up	1.86	up
PFKFB2	22673_3_at	6-PHOSPHOFRUCTO-2- KINASE	1.70	up	1.28	up
PFKFB2	209992_at		1.65	up	1.43	up
PFKFB3	202464_s_at	6-PHOSPHOFRUCTO-2- KINASE/FRUCTOSE-2,6- BISPHOSPHATASE 3	3.02	up	1.95	up
PGS1	219394_at	PHOSPHATIDYLGLYCERO- PHOSPHATE SYNTHASE	2.32	up	1.70	up
PHTF1	205702_at	PUTATIVE HOMEODOMAIN TRANSCRIPTION FACTOR 1	1.37	up	1.20	up
PIK3AP1	226459_at	PHOSPHOINOSITIDE 3- KINASE ADAPTOR PROTEIN 1	1.64	up	1.39	up
PLSCR1	241916_at	PHOSPHOLIPID SCRAMBLASE 1	2.01	up	1.57	up
PRO2852	223797_at		1.62	up	1.42	up
PRV1	219669_at	NEUTROPHIL-SPECIFIC ANTIGEN 1	7.08	up	4.72	up
PSTPIP2	219938_s_at	PROLINE/SERINE/ THREONINE PHOSPHATASE- INTERACTING PROTEIN 1	2.54	up	1.82	up
PTDSR	212723_at	CHROMOSOME 17 GENOMIC CONTIG, ALTERNATE ASSEMBLY	1.45	up	1.34	up
RABGEF1	218310_at	RAB GUANINE NUCLEOTIDE EXCHANGE FACTOR	2.03	up	1.59	up
RARA	228037_at	RETINOIC ACID RECEPTOR, ALPHA	1.54	up	1.20	up
RNASEL	229285_at	RIBONUCLEASE L	1.68	up	1.36	up
SAMSN1	1555638_a_at	SAM DOMAIN, SH3 DOMAIN, AND NUCLEAR LOCALIZATION SIGNALS 1	2.22	up	1.42	up
SAMSN1	220330_s_at		2.29	up	2.10	up
SEC15L1	226259_at	SEC15-LIKE 1 (<i>S. CEREVISIAE</i>) (SEC15L1), MRNA	1.64	up	1.43	up
SIPA1L2	225056_at	SIGNAL-INDUCED PROLIFERATION- ASSOCIATED GENE 1	2.02	up	1.52	up
SLC26A8	237340_at		2.01	up	1.48	up
SLC2A3	202499_s_at	SOLUTE CARRIER FAMILY 2 (FACILITATED GLUCOSE TRANSPORTER), MEMBER 3	1.87	up	1.71	up
SOCS3	227697_at	SUPPRESSOR OF CYTOKINE SIGNALING 3	2.84	up	2.15	up
SOD2	216841_s_at	SUPEROXIDE DISMUTASE 2	1.56	up	1.55	up
SPPL2A	226353_at	SIGNAL PEPTIDE PEPTIDASE-LIKE 2A	1.48	up	1.51	up

TABLE 31-continued

Exemplary biomarkers that discriminate between converters and non-converters						
Gene Symbol Column 1	Affymetrix Probeset name Column 2	Gene Name Column 3	T ₁₇ Values		T ₃₆ Values	
			Median FC Column 3	Direction Column 4	Median FC Column 5	Direction Column 6
SRPK1	202200_s_at	PROTEIN KINASE, SERINE/ARGININE-SPECIFIC, 1	1.80	up	1.46	up
STK3	204068_at	SERINE/THREONINE PROTEIN KINASE 3	1.74	up	1.33	up
SULF2	224724_at	SULFATASE 2 (SULF2), TRANSCRIPT VARIANT 2	1.36	down	1.35	down
SULF2	233555_s_at		1.37	down	1.30	down
T2BP	226117_at	TRAF-2 BINDING PROTEIN	2.90	up	1.90	up
T2BP	235971_at		1.47	up	1.27	up
T2BP	238858_at		1.32	up	1.21	up
TBC1D8	204526_s_at	TBC1 DOMAIN FAMILY, MEMBER 8	1.55	up	1.40	up
TCTEL1	201999_s_at	T-COMPLEX-ASSOCIATED- TESTIS-EXPRESSED 1	1.46	up	1.22	up
TGFBI	201506_at	TRANSFORMING GROWTH FACTOR, BETA-1	1.38	down	1.41	down
TTYH2	223741_s_at	TWEETY, <i>DROSOPHILA</i> , HOMOLOG OF, 2	1.28	down	1.24	down
WDFY3	212598_at	WD REPEAT AND FYVE DOMAIN CONTAINING 3	1.77	up	1.35	up
WDFY3	212606_at		1.56	up	1.35	up
WSB1	201296_s_at	WD REPEAT AND SOCS BOX- CONTAINING 1	1.74	up	1.52	up
ZDHHC19	231122_x_at	ZINC FINGER, DHHC DOMAIN CONTAINING 19 (ZDHHC19)	2.08	up	2.13	up
ZDHHC19	1553952_at		1.37	up	1.38	up
ZFP36L2	201367_s_at	ZINC FINGER PROTEIN 36, C3H TYPE-LIKE 2; ZFP36L2	1.23	down	1.28	down

[0532] Each of the sequences, genes, proteins, and probesets identified in Table 31 is hereby incorporated by reference herein in its entirety.

[0533] Table 31, above, provides a list of select biomarkers of the present invention. Where known, gene names are provided. Column two of Table 32, below, provides the GenBank® database accession numbers for the human nucleotide sequences of the biomarkers listed in Table 31, where known. Column three of Table 32 further provides the GenBank® database accession numbers for the corresponding amino acid sequences of the biomarkers of Table 31, where known. The biomarkers of the present invention include, but are not limited to, the genes and proteins identified by the accession numbers of Table 32, splicing variants thereof, discriminating

fragments of mRNA, cDNA or other nucleic acids and/or peptides corresponding to all or a discriminating portion of such genes and proteins, etc.

[0534] These gene and protein accession numbers are provided in order to identify some of the biomarkers of the present invention. GenBank® is the publicly available genetic sequence database of the National Institutes of Health (NIH), and is an annotated collection of all publicly available DNA sequences (see, e.g., Nucleic Acids Research 2004 Jan. 1; 32(1):23-26, which is incorporated by reference herein in its entirety). GenBank® is part of the International Nucleotide Sequence Database Collaboration, which comprises the DNA DataBank of Japan (DDBJ), the European Molecular Biology Laboratory (EMBL), and GenBank at the National Center for Biotechnology Information (NCBI).

TABLE 32

Gene and protein accession numbers for exemplary biomarkers that discriminate between converters and non-converters				
Gene Symbol Column 1	Affymetrix Probeset name Column 2	Gene Name Column 3	Gene Accession Number Column 4	Protein Accession Number Column 5
	1555785_a_at	EST		
<NA>	227150_at	EST		
<NA>	238973_s_at	EST		
<NA>	239893_at	EST		
<NA>	237563_s_at	EST		
<NA>	244313_at	EST		

TABLE 32-continued

Gene and protein accession numbers for exemplary biomarkers that discriminate between converters and non-converters				
Gene Symbol Column 1	Affymetrix Probeset name Column 2	Gene Name Column 3	Gene Accession Number Column 4	Protein Accession Number Column 5
<NA>	237071_at	EST		
<NA>	229934_at	EST		
<NA>	1555311_at	EST		
<NA>	233264_at	EST		
<NA>	239780_at	EST		
<NA>	238405_at	EST		
3'HEXO	226416_at	HISTONE MRNA 3' END	NM_153332	NP_699163
3'HEXO	231852_at	EXORIBONUCLEASE		
ADORA2A	205013_s_at	ADENOSINE A2 RECEPTOR	NM_000675	NP_000666
ANXA3	209369_at	ANNEXIN A3	NM_005139	NP_005130
ASAH1	214765_s_at	N-ACYLSPHINGOSINE	NM_014435	NP_055250
ASAH1	232072_at	AMIDOHYDROLASE-LIKE		
ASAH1	227135_at	PROTEIN		
ATP11B	1554557_at	ATPASE, CLASS VI, TYPE 11B	XM_087254	XP_087254
ATP6V1C1	202872_at	ATPASE, H+ TRANSPORTING, LYSOSOMAL, 42-KD, V1 SUBUNIT C, ISOFORM 1	NM_001695 NM_001007254	NP_001686 NP_001007255
B4GALT5	221485_at	BETA-1,4- GALACTOSYLTRANSFERASE	NM_004776	NP_004767
BASP1	202391_at	BRAIN-ABUNDANT SIGNAL PROTEIN	NM_006317	NP_006308
BAZ1A	217986_s_at	BROMODOMAIN ADJACENT TO ZINC FINGER DOMAIN, 1A	NM_013448 NM_182648	NP_038476 NP_872589
BCL6	203140_at	B-CELL LYMPHOMA 6	NM_001706 NM_138931	NP_001697 NP_620309
BMX	206464_at	BONE MARROW KINASE, X- LINKED	NM_001721 NM_203281	NP_001712 NP_975010
C16orf7	205781_at	CHROMOSOME 16 OPEN- READING FRAME 7	NM_004913	NP_004904
C20orf32	1554786_at	CHROMOSOME 20 OPEN- READING FRAME 32	NM_020356	NP_065089
C3F	203547_at	COMPLEMENT COMPONENT 3	NM_005768	NP_005759
C8FW	202241_at	C8FW GENE; PHOSPHOPROTEIN.	NM_025195	NP_079471
CEACAM1	209498_at	CARCINOEMBRYONIC	NM-001712	NP_001703
CEACAM1	211883_x_at	ANTIGEN-RELATED CELL ADHESION MOLECULE 1		
CECR1	219505_at	CAT EYE SYNDROME CHROMOSOME REGION, CANDIDATE 1	NM_017424 NM_177405	NP_059120 NP_803124
CHCHD7	222701_s_at	COILED-COIL-HELIX DOMAIN-CONTAINING PROTEIN 7	NM_001011667 NM_001011668 NM_001011669 NM_001011670 NM_001011671	NP_001011667 NP_001011668 NP_001011669 NP_001011670 NP_001011671
CHSY1	203044_at	CARBOHYDRATE SYNTHASE 1	NM_024300 NM_014918	NP_077276 NP_055733
CKLF	223451_s_at	CHEMOKINE-LIKE FACTOR	NM_016326	NP_057410
CKLF	219161_s_at		NM_016951 NM_181640 NM_181641	NP_058647 NP_857591 NP_857592
CL25022	217883_at	C2ORF25	NM_015702	NP_056517
CPD	201940_at	CARBOXYPEPTIDASE D	NM_001304	NP_001295
CPD	201941_at			
CRTAP	1554464_a_at	CARTILAGE-ASSOCIATED PROTEIN	NM_006371	NP_006362
DHRS9	219799_s_at	MEMBRANE PROTEIN, PALMITOYLATED 3; MPP3	NM_005771 NM_199204	NP_005762 NP_954674
EIF4G3	201936_s_at	EUKARYOTIC TRANSLATION INITIATION FACTOR 4-GAMMA, 3	NM_003760	NP_003751
FAD104	218618_s_at	FIBRONECTIN TYPE III	NM_022763	NP_073600
FAD104	225032_at	DOMAIN CONTAINING 3B		
FAD104	222692_s_at	(FNDC3B)		
FAD104	222693_at			
FCGR1A	214511_x_at	FC FRAGMENT OF IGG, HIGH	NM_000566	NP_000557
FCGR1A	216950_s_at	AFFINITY IA		

TABLE 32-continued

Gene and protein accession numbers for exemplary biomarkers that discriminate between converters and non-converters				
Gene Symbol Column 1	Affymetrix Probeset name Column 2	Gene Name Column 3	Gene Accession Number Column 4	Protein Accession Number Column 5
FLJ11175	229005_at		NM_018349	NP_060819
FLJ11175	220603_s_at			
FLJ11259	218627_at		NM_018370	NP_060840
FLJ11795	220112_at		NM_024669	NP_078945
FLJ22833	219334_s_at	HYPOTHETICAL PROTEIN FLJ22833	NM_022837	
G0S2	213524_s_at		NM_015714	NP_056529
GADD45B	207574_s_at	GROWTH ARREST- AND DNA	NM_015675	NP_056490
GADD45B	209304_x_at	DAMAGE-INDUCIBLE GENE GADD45		
GK	214681_at	GLYCEROL KINASE	NM_000167	NP_000158
			NM_203391	NP_976325
GPR160	223423_at	G PROTEIN-COUPLED RECEPTOR 160	NM_014373	NP_055188
HLA-DMA	217478_s_at	HLA-D	NM_006120	NP_006111
HLA-DMB	203932_at	HISTOCOMPATIBILITY TYPE	NM_002118	NP_002109
HLA-DPA1	211991_s_at		NM_033554	NP_291032
HLA-DQB1	209823_x_at		NM_002123	NP_002114
HLA-DRA	210982_s_at		NM_002123	NP_002114
HLA-DRA	208894_at			
HLA-DRB1	215193_x_at		NM_002124	NP_002115
HLA-DRB1	209312_x_at			
HLA-DRB4	204670_x_at		NM_021983	NP_068818
HLA-DRB4	208306_x_at			
HPGD	203913_s_at	15- HYDROXYPROSTAGLANDIN DEHYDROGENASE	NM_000860	NP_000851
		HYDROXYPROSTAGLANDIN DEHYDROGENASE 15-(NAD)		
HRPT2	218578_at	HYPERPARATHYROIDISM 2	NM_024529	NP_078805
HSPC163	228437_at	HSPC163 PROTEIN	NM_014184	NP_054903
HSPC163	218728_s_at			
ID1I	204615_x_at	ISOPENTENYL- DIPHOSPHATE DELTA- ISOMERASE	NM_004508	NP_004499
IL18R1	206618_at	INTERLEUKIN 18 RECEPTOR 1	NM_003855	NP_003846
KCNE1	236407_at	POTASSIUM CHANNEL, VOLTAGE-GATED, ISK- RELATED SUBFAMILY	NM_000219	NP_000210
KIF1B	225878_at	KINESIN FAMILY MEMBER 1B	NM_015074	NP_055889
			NM_183416	NP_904325
KREMEN1	227250_at	KRINGLE CONTAINING TRANSMEMBRANE PROTEIN 1	NM_032045	NP_114434
			NM_153379	NP_700358
LDLR	202068_s_at	LOW DENSITY LIPOPROTEIN RECEPTOR	NM_000527	NP_000518
LIMK2	202193_at	LIM DOMAIN KINASE 2	NM_005569	NP_005560
			NM_016733	NP_057952
LOC199675	235568_at	HYPOTHETICAL PROTEIN	NM_174918	NP_777578
LOC284829	225669_at	LOC199675		
LOC285771	237870_at	HYPOTHETICAL PROTEIN LOC285771)		
LRG1	228648_at	LEUCINE-RICH ALPHA-2- GLYCOPROTEIN 1	NM_052972	NP_443204
MGC22805	239196_at	NOVEL GENE (MGC22805),		
MGC22805	238439_at			
MPEG1	226841_at	MACROPHAGE EXPRESSED GENE 1	XM_166227	XP_166227
OAT	201599_at	ORNITHINE AMINOTRANSFERASE DEFICIENCY	NM_000274	NP_000265
ORF1-FL49	224707_at	PUTATIVE NUCLEAR PROTEIN ORF1-FL49	NM_032412	NP_115788
PDCD1LG1	227458_at	PROGRAMMED CELL DEATH 1 LIGAND 1	NM_014143	NP_054862
PFKFB2	226733_at	6-PHOSPHOFRUCTO-2- KINASE	NM_006212	NP_006203
PFKFB2	209992_at			

TABLE 32-continued

Gene and protein accession numbers for exemplary biomarkers that discriminate between converters and non-converters				
Gene Symbol Column 1	Affymetrix Probeset name Column 2	Gene Name Column 3	Gene Accession Number Column 4	Protein Accession Number Column 5
PFKFB3	202464_s_at	6-PHOSPHOFRUCTO-2-KINASE/FRUCTOSE-2,6-BISPHOSPHATASE 3	NM_004566	NP_004557
PGS1	219394_at	PHOSPHATIDYLGLYCERO-PHOSPHATE SYNTHASE	NM_024419	NP_077733
PHTF1	205702_at	PUTATIVE HOMEODOMAIN TRANSCRIPTION FACTOR 1	NM_006608	NP_006599
PIK3AP1	226459_at	PHOSPHOINOSITIDE 3-KINASE ADAPTOR PROTEIN 1	NM_152309	NP_689522
PLSCR1	241916_at	PHOSPHOLIPID SCRAMBLASE 1	NM_021105	NP_066928
PRO2852	223797_at	HYPOTHETICAL PROTEIN PRO2852		
PRV1	219669_at	NEUTROPHIL-SPECIFIC ANTIGEN 1 (POLYCYTHEMIA RUBRA VERA 1)	NM_020406	NP_065139
PSTPIP2	219938_s_at	PROLINE/SERINE/THREONINE PHOSPHATASE-INTERACTING PROTEIN 1 (PROLINE-SERINE-THREONINE PHOSPHATASE INTERACTING PROTEIN 2)	NM_024430	NP_077748
PTDSR	212723_at	CHROMOSOME 17 GENOMIC CONTIG, ALTERNATE ASSEMBLY (PHOSPHATIDYLSERINE RECEPTOR)	NM_015167	NP_055982
RABGEF1	218310_at	RAB GUANINE NUCLEOTIDE EXCHANGE FACTOR (RAB GUANINE NUCLEOTIDE EXCHANGE FACTOR (GEF) 1)	NM_014504	NP_055319
RARA	228037_at	RETINOIC ACID RECEPTOR, ALPHA	NM_000964	NP_000955
RNASEL	229285_at	RIBONUCLEASE L	NM_021133	NP_066956
SAMSN1	1555638_a_at	SAM DOMAIN, SH3 DOMAIN, AND NUCLEAR LOCALIZATION SIGNALS 1	NM_022136	NP_071419
SAMSN1	220330_s_at	LOCALIZATION SIGNALS 1		
SEC15L1	226259_at	SEC15-LIKE 1 (S. <i>CEREVISIAE</i>) (SEC15L1), MRNA	NM_019053	NP_061926
SIPA1L2	225056_at	SIGNAL-INDUCED PROLIFERATION-ASSOCIATED GENE 1 (SIGNAL-INDUCED PROLIFERATION-ASSOCIATED 1 LIKE 2)	NM_020808	NP_065859
SLC26A8	237340_at	SOLUTE CARRIER FAMILY 26, MEMBER 8	NM_052961	NP_443193
SLC2A3	202499_s_at	SOLUTE CARRIER FAMILY 2 (FACILITATED GLUCOSE TRANSPORTER), MEMBER 3	NM_138718	NP_619732
SOCS3	227697_at	SUPPRESSOR OF CYTOKINE SIGNALING 3	NM_003955	NP_003946
SOD2	216841_s_at	SUPEROXIDE DISMUTASE 2	NM_000636	NP_000627
SPPL2A	226353_at	SIGNAL PEPTIDE PEPTIDASE-LIKE 2A	NM_032802	NP_116191
SRPK1	202200_s_at	PROTEIN KINASE, SERTNE/ARGININE-SPECIFIC, 1 (SFRS PROTEIN KINASE 1)	NM_003137	NP_003128
STK3	204068_at	SERINE/THREONINE PROTEIN KINASE 3	NM_006281	NP_006272
SULF2	224724_at	SULFATASE 2 (SULF2),	NM_198596	NP_940998
SULF2	233555_s_at	TRANSCRIPT VARIANT 2		
T2BP	226117_at	TRAF-2 BINDING PROTEIN	NM_052864	NP_443096
T2BP	235971_at	(TRAF-INTERACTING		
T2BP	238858_at	PROTEIN WITH A FORKHEAD-ASSOCIATED DOMAIN)		

TABLE 32-continued

Gene and protein accession numbers for exemplary biomarkers that discriminate between converters and non-converters				
Gene Symbol Column 1	Affymetrix Probeset name Column 2	Gene Name Column 3	Gene Accession Number Column 4	Protein Accession Number Column 5
TBC1D8	204526_s_at	TBC1 DOMAIN FAMILY, MEMBER 8	NM_007063	NP_008994
TCTEL1	201999_s_at	T-COMPLEX-ASSOCIATED-TESTIS-EXPRESSED 1	NM_006519	NP_006510
TGFBI	201506_at	TRANSFORMING GROWTH FACTOR, BETA-1	NM_000358	NP_000349
TTYH2	223741_s_at	TWEETY, <i>DROSOPHILA</i> , HOMOLOG OF, 2	NM_032646 NM_052869	NP_116035 NP_443101
WDFY3	212598_at	WD REPEAT AND FYVE	NM_014991	NP_055806
WDFY3	212606_at	DOMAIN CONTAINING 3	NM_178583	NP_848698
WSB1	201296_s_at	WD REPEAT AND SOCS BOX-CONTAINING 1	NM_178585	NP_848700
			NM_015626	NP_056441
			NM_134264	NP_599026
ZDHHHC19	231122_x_at	ZINC FINGER, DHHC	NM_144637	NP_653238
ZDHHHC19	1553952_at	DOMAIN CONTAINING 19 (ZDHHHC19)		
ZFP36L2	201367_s_at	ZINC FINGER PROTEIN 36, C3H TYPE-LIKE 2; ZFP36L2	NM_006887	NP_008818

[0535] Each of the sequences, genes, proteins, and probesets identified in Table 32 is hereby incorporated by reference herein in its entirety.

6.8 Biomarker Combinations Based on Additional Filtering Criteria

[0536] Section 6.6 describes exemplary biomarkers that discriminate between converters and nonconverters. Section 6.7 describes one exemplary combination of the biomarkers of Section 6.6. The biomarkers of Section 6.7 were identified by the application of an additional filtering criterion to the biomarkers of Section 6.6. This section describes additional combinations of the biomarkers identified in Section 6.7. The subsections identified in this section discriminate between converters and nonconverters.

[0537] Table 33 lists biomarkers in one exemplary combination. The combination detailed in Table 33 was identified by taking the list of biomarkers in Table 31 and imposing additional filtering criteria. These additional criteria include a requirement that each respective biomarker under consideration exhibit at least a 1.2x fold change between the median feature value for the respective biomarker among the subjects that acquired sepsis during a defined time period (sepsis subjects) and the median value for the respective biomarker among subjects that do not acquire sepsis during the defined time period (SIRS subjects) in the T₋₁₂ baseline data described in Section 6.5. Furthermore, the summation of the PAM score, CART score, and RF score for the biomarker in the T₋₁₂ baseline data time period had to exceed unity. Application of these additional filtering criteria reduced the biomarkers from the 130 found in Table 31, to ten biomarkers.

TABLE 33

Exemplary combination of biomarkers that discriminate between converters and non-converters						
Gene Symbol Column 1	Affymetrix Probeset name Column 2	Gene Name Column 3	T ₋₁₂ Values		T ₋₃₆ Values	
			Median FC Column 4	Direction Column 5	Median FC Column 6	Direction Column 7
CL25022	1555785_a_at	EST	1.34	up	1.31	up
	217883_at		1.36	up	1.31	up
ID11	204615_x_at	ISOPENTENYL-DIPHOSPHATE DELTA-ISOMERASE	1.51	up	1.31	up
MGC22805	239196_at	NOVEL GENE (MGC22805)	2.30	up	1.86	up
ORF1-FL49	224707_at		1.75	up	1.65	up
ZDHHHC19	1553952_at		1.37	up	1.38	up
CHSY1	203044_at	CARBOHYDRATE SYNTHASE 1	1.78	up	1.24	up

TABLE 33-continued

Exemplary combination of biomarkers that discriminate between converters and non-converters						
Gene Symbol Column 1	Affymetrix Probeset name Column 2	Gene Name Column 3	T ₁₂ Values		T ₃₆ Values	
			Median FC Column 4	Direction Column 5	Median FC Column 6	Direction Column 7
SLC2A3	202499_s_at	SOLUTE CARRIER FAMILY 2 (FACILITATED GLUCOSE TRANSPORTER), MEMBER 3	1.87	up	1.71	up
FAD104	225032_at		1.63	up	1.41	up
T2BP	235971_at		1.47	up	1.27	up

[0538] Each of the sequences, genes, proteins, and probesets identified in Table 33 is hereby incorporated by reference.

[0539] Table 34 lists biomarkers in yet another exemplary combination of biomarkers. The combination detailed in Table 34 was identified by taking the list of biomarkers in Table 31 and imposing the additional requirement that each biomarker is annotated with a corresponding known gene and

that such a gene has a known biological function. Methods, tables, software and other resources for addressing this latter question are available from the Gene Ontology Consortium, (www.geneontology.org), which is hereby incorporated by reference in its entirety. Application of these additional filtering criteria reduced the biomarkers from the 130 found in the set of Table 31, to 52 biomarkers, representing 42 unique gene sequences (see FIG. 30).

TABLE 34

Exemplary combination of biomarkers that discriminate between converters and non-converters	
Gene Symbol	Corresponding Gene Name
(BCL6 na)	(B-cell CLL/lymphoma 6 (zinc finger protein 51) LOC389185)
(HLA-DRB1, 3, 4, 5)	(major histocompatibility complex class II DR beta 1 3, 4, 5)
(RABGEF1 na)	(LOC401368 LOC402538 RAB guanine nucleotide exchange factor (GEF) 1)
3HEXO	3 exoribonuclease
ADORA2A	adenosine A2a receptor
ANKRD22	ankyrin repeat domain 22
ANXA3	annexin A3
ATP11B	ATPase Class VI type 11B
ATP6V1C1	ATPase H+ transporting lysosomal 42 kDa VI subunit C isoform 1
BASP1	brain abundant membrane attached signal protein 1
BAZ1A	bromodomain adjacent to zinc finger domain 1A
C16orf7	chromosome 16 open reading frame 7
CD4	CD4 antigen (p55)
CEACAM1	carcinoembryonic antigen-related cell adhesion molecule 1 (biliary glycoprotein)
CECR1	cat eye syndrome chromosome region candidate 1
CKLF	chemokine-like factor
CPD	carboxypeptidase D
EIF4G3	eukaryotic translation initiation factor 4 gamma 3
FCGR1A	Fc fragment of IgG high affinity Ia receptor for (CD64)
G0S2	putative lymphocyte G0/G1 switch gene
GADD45B	growth arrest and DNA-damage-inducible beta
HLA-DMB	major histocompatibility complex class II DM beta
HLA-DPA1	major histocompatibility complex class II DP alpha 1
HLA-DQB1	major histocompatibility complex class II DQ beta 1
HLA-DRA	major histocompatibility complex class II DR alpha
HPGD	hydroxyprostaglandin dehydrogenase 15-(NAD)
IL18R1	interleukin 18 receptor 1
KCNE1	potassium voltage-gated channel Isk-related family member 1
LDLR	low density lipoprotein receptor (familial hypercholesterolemia)
PDCD1LG1	programmed cell death 1 ligand 1
PHTF1	putative homeodomain transcription factor 1
PRV1	polycythemia rubra vera 1
PTDSR	phosphatidylserine receptor
RARA	retinoic acid receptor alpha

TABLE 34-continued

Exemplary combination of biomarkers that discriminate between converters and non-converters	
Gene Symbol	Corresponding Gene Name
RNASEL	ribonuclease L (25-oligoisoadenylate synthetase-dependent)
SEC15L1	SEC15-like 1 (<i>S. cerevisiae</i>)
SLC26A8	solute carrier family 26 member 8
SLC2A3	solute carrier family 2 (facilitated glucose transporter) member 3
STK3	serine/threonine kinase 3 (STE20 homolog yeast)
TGFBI	transforming growth factor beta-induced 68 kDa
XRN1	5-3 exoribonuclease 1
ZFP36L2	zinc finger protein 36 C3H type-like 2

[0540] Each of the sequences, genes, proteins, and probesets identified in Table 34 is hereby incorporated by reference.

[0541] In one embodiment, the biomarker profile comprises a plurality of biomarkers that collectively contain at least five, at least ten at least fifteen, at least twenty, at least thirty, between 2 and 5, between 3 and 7, or less than 15 of the sequences of the probesets of Table 32, or complements thereof, or genes including one of at least five of the sequences or complements thereof, or a discriminating fragment thereof, or an amino acid sequence encoded by any of the foregoing nucleic acid sequences, or any discriminating fragment of such an amino acid sequence. Such biomarkers can be mRNA transcripts, cDNA or some other form of amplified nucleic acid or proteins.

[0542] In one embodiment, the biomarker profile comprises a plurality of biomarkers that collectively contain at least five, at least ten at least fifteen, at least twenty, at least thirty, between 2 and 5, between 3 and 7, or less than 15 of the sequences of the probesets of Table 33, or complements thereof, or genes including one of at least five of the sequences or complements thereof, or a discriminating fragment thereof, or an amino acid sequence encoded by any of the foregoing nucleic acid sequences, or any discriminating fragment of such an amino acid sequence. Such biomarkers can be, for example, mRNA transcripts, cDNA or some other nucleic acid, for example amplified nucleic acid, or proteins.

[0543] In one embodiment, the biomarker profile comprises a plurality of biomarkers that collectively contain at least five, at least ten at least fifteen, at least twenty, at least thirty, between 2 and 5, between 3 and 7, or less than 15 of the sequences of the probesets of Table 34, or complements thereof, or genes including one of at least five of the sequences or complements thereof, or a discriminating fragment thereof, or an amino acid sequence encoded by any of the foregoing nucleic acid sequences, or any discriminating fragment of such an amino acid sequence. Such biomarkers can be, for example, mRNA transcripts, cDNA or some other nucleic acid, for example amplified nucleic acid, or proteins.

[0544] In one embodiment, the biomarker profile comprises a plurality of biomarkers that collectively contain at least five, at least ten at least fifteen, at least twenty, at least thirty, between 2 and 5, between 3 and 7, or less than 15 of the sequences of the probesets of Table 33 or Table 34, or complements thereof, or genes including one of at least five of the sequences or complements thereof, or a discriminating fragment thereof, or an amino acid sequence encoded by any of the foregoing nucleic acid sequences, or any discriminating fragment of such an amino acid sequence. Such biomarkers

can be, for example, mRNA transcripts, cDNA or some other nucleic acid, for example amplified nucleic acid, or proteins.

[0545] In one embodiment, the biomarker profile comprises a biomarker that has the sequence of U133 plus 2.0 probeset SLC2A3 or a complement thereof, or a gene including the sequence of the probeset SLC2A3 or a complement thereof, or a discriminating fragment thereof, or an amino acid sequence encoded by any of the foregoing nucleic acid sequences, or any discriminating fragment of such an amino acid sequence. Such biomarkers can be, for example, mRNA transcripts, cDNA or some other nucleic acid, for example amplified nucleic acid, or proteins.

[0546] In the case where a biomarker is based upon a gene that includes the sequence of a probeset listed in Table 30, 31, 32, 33, or 34 or a complement thereof, the biomarker can be, for example, a transcript made by the gene, a complement thereof, or a discriminating fragment or complement thereof, or a cDNA thereof, or a discriminating fragment of the cDNA, or a discriminating amplified nucleic acid molecule corresponding to all or a portion of the transcript or its complement, or a protein encoded by the gene, or a discriminating fragment of the protein, or an indication of any of the above. Further still, the biomarker can be, for example, a protein encoded by a gene that includes a probeset sequence described in Table 30, 31, 32, 33 or 34, or a discriminating fragment of the protein, or an indication of the above. Here, a discriminating molecule or fragment is a molecule or fragment that, when detected, indicates presence or abundance of the above-identified transcript, cDNA, amplified nucleic acid, or protein.

6.9 Differential Gene Expression in the Th1/Th2 Pathway in SIRS and Sepsis Patients

[0547] This section describes methods used to identify a set of biomarkers that discriminate between converters and non-converters, using the methods described, e.g., in Section 5.10, supra. Briefly, 97 SIRS subject were admitted to critical care units of a major university trauma center were evaluated using the methods described in Section 6.1. Comparisons were made using T₋₃₆ and T₋₁₂ static data described in Sections 6.3 and 6.4, respectively. The subjects were divided into two classes: converters (47) and nonconverters (50). Blood samples drawn from converters were time matched to samples from nonconverters in order to perform comparisons, as described in Sections 6.3 and 6.4, respectively. The blood samples were collected and analyzed as described in Section 6.2.

[0548] Biomarkers that discriminated between converters and nonconverters with (i) a Wilcoxon (adjusted) p value of 0.05 or less and (ii) an exhibited a mean fold differential expression value between converters and nonconverters of 1.2 or greater in either the T_{-36} or the T_{-12} static test were selected as the set of discriminating biomarkers. This set of discriminating biomarkers was then filtered using an annotation data based filtering rule imposed by DAVID 2.0, which is available from the National Institutes of Health (see, <http://apps1.niaid.nih.gov/david/>, the contents of which are incorporated by reference herein in their entirety). Specifically, that annotation data based filtering rule imposed by David 2.0 had the form of annotation rule 4 in Section 5.10, reproduce below

Annotation rule 4.

Select all biomarkers that are in biological pathway X.

The specific form of this annotation data based filtering rule in this example was

Select all biomarkers that are in the Th1/Th2 biological pathway (cell differentiation pathway).

Table 35 below lists the Affymetrix U133 plus 2.0 probesets that are in genes known to be involved in this Th1/Th2 cell differentiation pathway.

TABLE 35

U133 plus 2.0 Probesets in genes involved in the Th1/Th2 cell differentiation pathway.		
Symbol	U133 + 2.0 probeset	P value (adjusted)
CD28	211856_x_at	0.018
CD28	211861_x_at	
CD28	206545_at	
CD86	205685_at	0.0034
CD86	205685_at	0.0187
CD86	210895_s_at	0.0034
CD86	210895_s_at	0.0187
CD86	205686_s_at	0.0114
HLA-DRA	210982_s_at	0.0034
HLA-DRA	210982_s_at	0.0187
HLA-DRA	208894_at	0.0034
HLA-DRA	208894_at	0.0187
HLA-DRB1	221491_x_at	
HLA-DRB1	217323_at	
HLA-DRB1	217362_x_at	0.0034
HLA-DRB1	217362_x_at	0.0472
HLA-DRB1	215193_x_at	0.0034
HLA-DRB1	215193_x_at	0.0187
HLA-DRB1	209728_at	
HLA-DRB1	204670_x_at	0.0034
HLA-DRB1	204670_x_at	0.0187
HLA-DRB1	208306_x_at	0.0034
HLA-DRB1	208306_x_at	0.0187
HLA-DRB1	209312_x_at	0.0034
HLA-DRB1	209312_x_at	0.0187
HLA-DRB1	215666_at	
HLA-DRB1	215669_at	
HLA-DRB3	221491_x_at	
HLA-DRB3	217323_at	
HLA-DRB3	217362_x_at	0.0034

TABLE 35-continued

U133 plus 2.0 Probesets in genes involved in the Th1/Th2 cell differentiation pathway.		
Symbol	U133 + 2.0 probeset	P value (adjusted)
HLA-DRB3	217362_x_at	0.0472
HLA-DRB3	215193_x_at	0.0034
HLA-DRB3	215193_x_at	0.0187
HLA-DRB3	209728_at	
HLA-DRB3	204670_x_at	0.0034
HLA-DRB3	204670_x_at	0.0187
HLA-DRB3	208306_x_at	0.0034
HLA-DRB3	208306_x_at	0.0187
HLA-DRB3	209312_x_at	0.0034
HLA-DRB3	209312_x_at	0.0187
HLA-DRB3	215666_at	
HLA-DRB3	215669_at	
HLA-DRB4	221491_x_at	
HLA-DRB4	217323_at	
HLA-DRB4	217362_x_at	0.0034
HLA-DRB4	217362_x_at	0.0472
HLA-DRB4	215193_x_at	0.0034
HLA-DRB4	215193_x_at	0.0187
HLA-DRB4	209728_at	
HLA-DRB4	204670_x_at	0.0034
HLA-DRB4	204670_x_at	0.0187
HLA-DRB4	208306_x_at	0.0034
HLA-DRB4	208306_x_at	0.0187
HLA-DRB4	209312_x_at	0.0034
HLA-DRB4	209312_x_at	0.0187
HLA-DRB4	215666_at	
HLA-DRB4	215669_at	
HLA-DRB5	221491_x_at	
HLA-DRB5	217323_at	
HLA-DRB5	217362_x_at	0.0034
HLA-DRB5	217362_x_at	0.0472
HLA-DRB5	215193_x_at	0.0034
HLA-DRB5	215193_x_at	0.0187
HLA-DRB5	209728_at	
HLA-DRB5	204670_x_at	0.0034
HLA-DRB5	204670_x_at	0.0187
HLA-DRB5	208306_x_at	0.0034
HLA-DRB5	208306_x_at	0.0187
HLA-DRB5	209312_x_at	0.0034
HLA-DRB5	209312_x_at	0.0187
HLA-DRB5	215666_at	
HLA-DRB5	215669_at	
IFNG	210354_at	
IFNGR1	211676_s_at	0.00342
IFNGR1	242903_at	0.0034
IFNGR1	202727_s_at	0.0054
IFNGR2	231696_x_at	
IFNGR2	201642_at	0.0034
IL12A	207160_at	
IL12B	207901_at	
IL12RB1	239522_at	
IL12RB1	206890_at	
IL12RB2	206999_at	
IL18	206295_at	
IL18R1	206618_at	0.0034
IL18R1	206618_at	0.0187
IL2	207849_at	
IL2RA	211269_s_at	
IL2RA	206341_at	0.0247
IL4	207538_at	
IL4	207539_s_at	
IL4R	203233_at	0.0034
IL4R	203233_at	0.0187
TNFRSF5	222292_at	0.0126
TNFRSF5	215346_at	
TNFRSF5	205153_s_at	
TNFRSF5	35150_at	0.0086
TNFRSF5	207892_at	0.0034

[0549] Table 36 below identifies the genes that contain the probesets that remained in the set of discriminating biomarkers upon application of the annotation data based filtering rule.

TABLE 36

Identified genes.				
Gene name	Data source (static)	Adjusted p value	Fold-change (Median sepsis vs. Median SIRS)	Relative regulation
CD86	T ₋₁₂	0.003	1.56	Down
	T ₋₃₆	0.019	1.23	Down
HLA-DRA	T ₋₁₂	0.003	1.29	Down
	T ₋₃₆	0.019	1.23	Down
HLA-DRB1, 3, 4, 5	T ₋₁₂	0.003	1.25	Down
	T ₋₃₆	0.019	1.27	Down
IFNGR1	T ₋₁₂	0.003	1.39	Up
	T ₋₁₂	0.003	1.25	Up
IL18R1	T ₋₁₂	0.003	3.17	Up
	T ₋₃₆	0.019	2.37	Up
IL4R	T ₋₁₂	0.003	1.61	Up
	T ₋₃₆	0.019	1.39	Up

[0550] The genes in Table 36 represent biomarkers that discriminate between converters and converters. Further, these genes are in the Th1/Th2 cell differentiation pathway. The results in the table show that, although clinically similar, SIRS patients who subsequently developed sepsis expressed genes related to Th1/Th2 Cells differently than SIRS patients who remained uninfected. These differences occurred prior to the onset of clinical sepsis. For a discussion of Th1/Th2 cell differentiation pathway genes and related genes, see, e.g., Abbas et al., 1996, Functional diversity of helper T lymphocytes, Nature 383:787-793; Fearon and Locksley, 1996, Science 272:50-53; and Mossman and Sad, 1996, Immunol. Today 17:138-146; each of which is hereby incorporated by reference in its entirety.

6.10 RT-PCR

[0551] In Section 6.1, it was noted that two Paxgene (RNA) tubes were drawn from each subject in the study on each day of the study. One tube was used for microarray analysis as described in Section 6.2. The other tube was used for RT-PCR analysis. In this section, the correlation between the gene expression values obtained by RT-PCR and the gene expression values obtained by microarray is presented for three of the genes listed in Table 30, IL18R1, FCGR1A, and MMP9. In this comparison, static expression data from both assays (RT-PCR and microarray) for all time points measured in the subject were correlated to obtain a correlation coefficient. The correlations were computed within ‘R’, a public domain statistical computing language (<http://www.r-project.org/>, which is hereby incorporated by reference), using the following code:

```

corCalc <- function(x,y){
  n <- length(x)
  ## if there are any missing values in the data
  if(any(is.na(x)) || any(is.na(y))){
    ## index where missing values occur
    m.idx <- which(is.na(x))
    m.idx <- c(m.idx,which(is.na(y)))
  }
}

```

-continued

```

## remove missing values
x <- x[-m.idx]
y <- y[-m.idx]
## update length
n <- length(x)
}
R <- (n*sum(x*y)-sum(x)*sum(y))/(sqrt((n*sum(x^2) -
(sum(x)^2)*(n*sum(y^2) - (sum(y)^2))))
return(R)
}

```

[0552] FIG. 31 shows the correlation between IL18R1 expression, as determined by RT-PCR, and the intensity of the X206618_at probeset, as determined using the techniques described in Section 6.2, using all available time points across the training population. Each point in FIG. 31 is the gene expression value for a given subject in the training population from the RT-PCR data and the microarray data. Substantial correlation between the RT-PCR and the microarray data was found. In particular, the overall correlation between expression of IL18R1 as determined by RT-PCR and microarray data for X206618_at was 0.85.

[0553] FIG. 32 shows the correlation between FCGR1A expression, as determined by RT-PCR, and the intensity of the X214511_x_at, X216950_s_at and X216951_at probesets, as determined using the techniques described in Section 6.2, using all available time points in the training population. Each point in FIG. 32 is the gene expression value for a given subject in the training population from the RT-PCR data and the microarray data. As is evident in FIG. 32, the overall correlation between expression of FCGR1A and each of the two FCGR1A probesets that are found in Table 30, X214511_x_at and X216950_s_at, was significant. In particular the correlation coefficient between FCGR1A and X214511_x_at was 0.88. Likewise, the correlation coefficient between and FCGR1A and X216950_s_at was 0.88. The overall correlation between expression of FCGR1A and the FCGR1A probeset not found in Table 30, X216951_at, was 0.53, which was not as significant as the other two probesets.

[0554] FIG. 33 shows the correlation between MMP9 expression, as determined by RT-PCR, and the intensity of the X203936_s_at probeset, as determined using the techniques described in Section 6.2, using all available time points in the training population. Each point in FIG. 33 is the gene expression value for a given subject in the study from the RT-PCR data and the microarray data. Substantial correlation between the RT-PCR and the microarray data was found. In particular, the overall correlation between expression of MMP9 as determined by RT-PCR and microarray data for X203936_s_at was 0.87.

[0555] FIG. 34 shows the correlation between CD86 expression, as determined by RT-PCR, and the intensity of the X205685_at, X205686_s_at, and X210895_s_at probesets, as determined using the techniques described in Section 6.2, using all available time points. Each point in FIG. 34 is the gene expression value for a given subject in the study from the RT-PCR data and the microarray data. As is evident in FIG. 34, the overall correlation between expression of CD86 and CD86 probeset that is found in Table 30, 210895_s_at, was significant (correlation coefficient of 0.71). The overall correlation between expression of CD86 and the probesets not found in Table 30, X205685_at, X205686_s_at, was not as significant (correlation coefficient of 0.66 and 0.56, respectively).

[0556] In one embodiment, a biomarker profile of the present invention comprises a plurality of biomarkers selected from Table 30, including at least one sequence of a probeset in the set of:

[0557] {X206618_at, X214511_x_at, X216950_s_at, X203936_s_at, and 210895_s_at}

or complements thereof, or genes including the sequence or a complement of the sequence thereof, or a discriminating fragment thereof, or an amino acid sequence encoded by any of the foregoing nucleic acid sequences, or any discriminating fragment of such an amino acid sequence. Such biomarkers can be, for example, mRNA transcripts, cDNA or some other nucleic acid, for example, amplified nucleic acid or proteins. In one embodiment, a biomarker profile of the present invention comprises a nucleic acid that codes for TGFB1, IL18R1, or FCGR1A, a discriminating portion of TGFB1, IL18R1, or FCGR1A, complements of such nucleic acids, proteins encoded by such nucleic acids, or antibodies that selectively bind to any of the foregoing.

6.11 Discovery of Select Nucleic Acid Biomarkers

[0558] The experiments described above identified a number of biomarkers that discriminate between sepsis and SIRS. In this example, a discovery process was performed in order to confirm which biomarkers differentiate between patients who subsequently develop sepsis (“sepsis patients”) and patients who do not (“SIRS patients”). In the discovery process, samples from SIRS patients and sepsis patients taken at: (i) date of entry, (ii) T_{-60} , (iii) T_{-36} , and (iv) T_{-12} data points were studied by RT-PCR, as described in Section 6.11.1 and by Affymetrix gene chip analysis, as described in Section 6.11.2.

6.11.1 RT-PCR Analysis

[0559] Biomarkers in multiple samples were measured by RT-PCR at multiple time points and analyzed in several different ways: static time of entry, static T_{-60} , static T_{-36} , baseline T_{-60} , baseline T_{-36} , and baseline T_{-12} data points. RT-PCR is described in Section 5.4.1.2, and 6.10, above. Representative of these analyses is the static T_{-12} data analysis which is described in detail below. In the T_{-12} static analysis, biomarkers features were measured using a specific blood sample, designated the T_{-12} blood sample, as defined in Section 6.4, above.

[0560] For the T_{-12} static analysis, there were 72 biomarkers measured on 96 samples. Each sample was collected from a different member the population. Of these features, 15 were transformed by log transformations, 5 by square root transformations and the remaining 52 were not transformed.

[0561] The 96 member population was initially split into a training set ($n=73$) and a validation set ($n=23$). The training set was used to estimate the appropriate classification algorithm parameters while the trained algorithm was applied to the validation set to independently assess performance. Of the 73 training samples, 36 were labeled Sepsis, meaning that the subjects developed sepsis at some point during the observation time period, and 37 were SIRS, meaning that they did not develop sepsis during the observation time period. Table 37 provides distributions of the race, gender and age for these samples.

TABLE 37

Distributions of the race, gender, and age for the training data				
Group	Gender	Black	Caucasian	Other
Sepsis	Male	10	14	1
	Female	0	10	1
SIRS	Male	5	22	0
	Female	0	10	0
Group	Minimum	Mean	Median	Maximum
Sepsis	18	43.2	40	80
SIRS	18	44.6	40	90

[0562] For the 23 validation samples, 12 were labeled Sepsis and 11 were labeled SIRS. Table 38 provides distributions of the race, gender and age for these samples.

TABLE 38

Distributions of the race, gender, and age for the validation data				
Group	Gender	Black	Caucasian	Other
Sepsis	Male	0	7	0
	Female	0	4	0
SIRS	Male	2	6	0
	Female	0	4	0
Group	Minimum	Mean	Median	Maximum
Sepsis	18	43.4	43	81
SIRS	19	51.9	51.5	85

[0563] Each sample in the training data was randomly assigned to one of ten groups used for cross-validation. The number of training samples in these groups ranged from 6 to 8. The samples were assigned in way that attempted to balance the number of sepsis and SIRS samples across folds. As described in more detail below, several different methods were used to judge whether select biomarkers discriminate between the Sepsis and SIRS groups.

[0564] Wilcoxon and Q-value tests. The first method used to identify discriminating biomarkers was a Wilcoxon test (unadjusted). The abundance value for a given biomarker across the samples in the training data was subjected to the Wilcoxon test. The Wilcoxon test considers both group classification (sepsis versus SIRS) and abundance value in order to compute a p value for the given biomarker. The p value provides an indication of how well the abundance value for the given biomarker across the samples collected in the training set discriminates between the sepsis and SIRS state. The lower the p value, the better the discrimination. When the p value is less than a specific confidence level, such as 0.05, an inference is made that the biomarker discriminates between the sepsis and SIRS phenotype. There were 33 significant biomarkers using this method (see Table 39).

[0565] The second method used to identify discriminating biomarkers was the Wilcoxon Test (adjusted). Due to the large number of biomarkers, 72, and the relatively small number of samples, 96, there was a high risk of finding falsely significant biomarkers. An adjusted p-value was used to counter this risk. In particular, the method of Benjamini and Hochberg, 1995, J.R. Statist. Soc. B 57, pp 289-300, which is hereby incorporated herein by reference in its entirety, was used to control the false discovery rate. Here, the false dis-

covery rate is defined as the number of biomarkers truly significant divided by the number of biomarkers declared significant. For example, if the adjusted p-value is less than 0.05, there is a 5% chance that the biomarker is a false discovery. Results using this test are reported in Table 39. There were 11851 significant biomarkers using this method (see Table 39). As used, herein, a biomarker is considered significant if it has a p-value of less than 0.05 as determined by the Wilcoxon test (adjusted).

[0566] The third method used to identify discriminating biomarkers was the use of Q values. In such an approach, the biomarkers are ordered by their q-values and if a respective biomarker has a Q value of X, then respective biomarker and all others more significant have a combined false discovery rate of X. However, the false discovery rate for any one biomarker may be much larger. There were 27 significant biomarkers using this method (see Table 39).

TABLE 39

Cumulative number of significant calls for the three methods. Note that all samples (training and validation) were used to compare Sepsis and SIRS groups. Missing biomarker feature values were not included in the analyses.							
	$\leq 1e-04$	≤ 0.001	≤ 0.01	≤ 0.025	≤ 0.05	≤ 0.1	≤ 1
p-value (unadjusted)	0	22	25	29	33	38	72
p-value (adjusted)	0	16	25	25	27	33	72
q-value	0	0	28	38	47	59	72

[0567] CART. In addition to analyzing the microarray data using Wilcoxon and Q-value tests in order to identify biomarkers that discriminate between the sepsis and SIRS subpopulations in the training set, classification and regression tree (CART) analysis was used. CART is described in Section 5.5.1, above. Specifically, the data summarized above was used to predict the disease state by iteratively partitioning the data based on the best single-variable split of the data. In other words, at each stage of the tree building process, the biomarker whose expression values across the training population best discriminate between the sepsis and SIRS population was invoked as a decision branch. Cross-validation was carried out, with the optimal number of splits estimated independently in each of the 10 iterations. The final tree is depicted in FIG. 36, and uses seven biomarkers: TNFSF13B, FCGR1A, HMOX1, MMP9, APAF1, APAF1.1, and CCL3.

[0568] FIG. 37 shows the distribution of the seven biomarkers used in the decision tree between the sepsis and SIRS groups in the training data set. In FIG. 37, the top of each box denotes the 75th percentile of the data across the training set and the bottom of each box denotes the 25th percentile, and the median value for each biomarker across the training set is drawn as a line within each box. The confusion matrix for the training data where the predicted classifications were made from the cross-validated model is given in Table 40. From this confusion matrix, the overall accuracy was estimated to be 68.5% with a 95% confidence interval of 56.6% to 78.9%. The estimated sensitivity was 72.2% and the estimated specificity was 64.9%.

TABLE 40

Confusion matrix for training samples using the cross-validated CART algorithm of FIG. 36		
Predicted	True Diagnosis	
	Sepsis	SIRS
Sepsis	26	13
SIRS	10	24

[0569] For the 23 validation samples held back from training data set, the overall accuracy was estimated to be 78.3% with a 95% confidence interval of 56.3% to 92.5%, sensitivity 66.7% and specificity 90.9%. Table 41 shows the confusion matrix for the validation samples.

TABLE 41

Confusion matrix for validation samples using the cross-validated CART algorithm		
Predicted	True Diagnosis	
	Sepsis	SIRS
Sepsis	8	1
SIRS	4	10

[0570] Random Forests. Another decision rule that can be developed using biomarkers of the present invention is a Random Forests decision tree. Random Forests is a tree based method that uses bootstrapping instead of cross-validation. For each iteration, a random sample (with replacement) is drawn and the largest tree possible is grown. Each tree receives a vote in the final class prediction. To fit a random forest, the number of trees (e.g. bootstrap iterations) is specified. No more than 500 were used in this example, but at least 50 are needed for a burn-in period. The number of trees was chosen based on the accuracy of the training data. For this data, 462 trees were used to train the algorithm (see FIG. 38). In FIG. 38, curve 3202 is a smoothed estimate of overall accuracy as a function of tree number. Curve 3804 is a smoothed curve of tree sensitivity as a function of tree number. Curve 3806 is a smoothed curve of tree specificity as a function of tree number. Using this algorithm, 49 biomarkers had non-zero importance and were used in the model. The random forest algorithm gauges biomarker importance by the average reduction in the training accuracy. The biomarkers were ranked by this method and are shown in FIG. 39. The random forest method uses a number of different decision trees. A biomarker is considered to have discriminating significance if it served as a decision branch of a decision tree from a significant random forest analysis. As used herein, a significant random forest analysis is one where the lower 95% confidence interval on accuracy by cross validation on a training data set is greater than 50% and the point estimate for accuracy on a validation set is greater than 65%.

[0571] The predicted confusion matrix for the training dataset using the decision tree developed using the Random Forest method is given in Table 42. From this confusion matrix, the overall accuracy was estimated to be 76.7% (confidence intervals cannot be computed when using the bootstrap accuracy estimate). The estimated sensitivity was 77.8% and the estimated specificity was 75.7%.

TABLE 42

Confusion matrix for training samples against the decision tree developed using the Random Forest method.		
Predicted	True Diagnosis	
	Sepsis	SIRS
Sepsis	28	8
SIRS	9	28

[0572] For the 23 validation samples held back from training, the overall accuracy was estimated to be 78.3% with a 95% confidence interval of 56.3% to 92.5%, sensitivity 75% and specificity 81.8%. Table 43 shows the confusion matrix for the validation samples.

TABLE 43

Confusion matrix for the validation samples against the decision tree developed using the Random Forest method.		
Predicted	True Diagnosis	
	Sepsis	SIRS
Sepsis	9	2
SIRS	3	9

[0573] MART. Multiple Additive Regression Trees (MART), also known as “gradient boosting machines,” was used to simultaneously assess the importance of biomarkers and classify the subject samples. Several fitting parameters are specified in this approach including (i) number of trees, (ii) step size (commonly referred to as “shrinkage”), and (iii) degree of interaction (related to the number of splits for each tree). More information on MART is described in Section 5.5.4 above. The degree of interaction was set to 1 to enforce an additive model (e.g. each tree has one split and only uses one biomarker).

[0574] Estimating interactions may require more data to function well. The step size was set to 0.05 so that the model complexity was dictated by the number of trees. The optimal number of trees was estimated by leaving out a random subset of cases at each fitting iteration, then assessing quality of prediction on that subset. After fitting more trees than were warranted, the point at which prediction performance stopped improving was estimated as the optimal point.

[0575] The estimated model used 15 trees and 6 biomarkers across all trees. The MART algorithm also provides a calculation of biomarker importance (summing to 100%), which are given in FIG. 40. Biomarkers with zero importance were excluded. FIG. 41 shows the distribution of the selected biomarkers between the Sepsis and SIRS groups.

[0576] Cross-validation was carried out, with the optimal number of trees estimated independently in each of the 10 iterations. The confusion matrix for the training data where the predicted classifications were made from the cross-validated model is given in Table 44. From this confusion matrix, the overall accuracy was estimated to be 75.3% with a 95% confidence interval of 63.9% to 84.7%. The estimated sensitivity was 72.2% and the estimated specificity was 78.4%.

TABLE 44

Confusion matrix for the training samples using the cross-validated MART algorithm.		
Predicted	True Diagnosis	
	Sepsis	SIRS
Sepsis	26	8
SIRS	10	29

[0577] For the 23 validation samples held back from training, the overall accuracy was estimated to be 78.3% with a 95% confidence interval of 56.3% to 92.5%, sensitivity 81.8% and specificity 75%. Table 45 shows the confusion matrix for the validation samples.

TABLE 45

Confusion matrix for the validation samples using the MART algorithm.		
Predicted	True Diagnosis	
	Sepsis	SIRS
Sepsis	9	3
SIRS	2	9

[0578] PAM. Yet another decision rule developed using biomarkers of the present invention is predictive analysis of microarrays (PAM), which is described in Section 5.5.2, above. In this method, a shrinkage parameter that determines the number of biomarkers used to classify samples is specified. This parameter was chosen via cross-validation. There were no biomarkers with missing values. Based on cross-validation, the optimal threshold value was 2.12, corresponding to 5 biomarkers. FIG. 42 shows the accuracy across different thresholds. In FIG. 42, curve 4202 is the overall accuracy (with 95% confidence interval bars). Curve 4204 shows decision rule sensitivity as a function of threshold value. Curve 4206 shows decision rule specificity as a function of threshold value. Using the threshold of 2.12, the overall accuracy for the training samples was estimated to be 80.8% with a 95% confidence interval of 70.9% to 87.9%. The estimated sensitivity was 89.2% and the estimated specificity was 72.2%. Table 46 shows the confusion matrix for the training data where the predicted classifications were made from the cross-validated models.

TABLE 46

Confusion matrix for training samples using cross-validated PAM algorithm		
Predicted	True Diagnosis	
	Sepsis	SIRS
Sepsis	33	10
SIRS	4	26

[0579] For the 23 validation samples held back from training, the overall accuracy was estimated to be 82.6% with a 95% confidence interval of 61.2% to 95%, sensitivity 91.7% and specificity 72.7%. Table 47 shows the confusion matrix for the validation samples.

TABLE 47

Confusion matrix for validation samples using cross-validated PAM algorithm		
Predicted	True Diagnosis	
	Sepsis	SIRS
Sepsis	11	3
SIRS	1	8

[0580] FIG. 43 shows the selected biomarkers, ranked by their relative discriminatory power, and their relative importance in the model.

[0581] FIG. 44 provides a summary of the CART, MART, PAM, and random forests (RF) classification algorithm (decision rule) performance and associated 95% confidence intervals. Fifty distinct biomarkers were selected from across all the algorithms illustrated in FIG. 44. The identity of these fifty selected features is found in FIG. 45, which further illustrates an overall ranking of these biomarkers for the T_{-12} data set. For the selected biomarkers, the x-axis depicts the percentage of times that it was selected. Within the percentage of times that biomarkers were selected, the biomarkers are ranked.

[0582] From the analysis of the T_{-12} data set and the other data sets, biomarkers were ranked according to how often they were included in the CART, MART, PAM, random forests. The results of this ranking is summarized in Table 48 below:

TABLE 48

Top ranked biomarkers as determined by RT-PCR					
Gene symbol	Gene Name	Gene Accession Number	Protein Accession Number	T_{-12} Hours	T_{-36} Hours
FCGR1A	FC FRAGMENT OF IGG, HIGH AFFINITY IA	NM_000566	NP_000557	1	1
MMP9	MATRIX METALLOPROTEINASE 9 (GELATINASE B, 92 KDA GELATINASE, 92 KDA TYPE IV COLLAGENASE)	NM_004994	NP_004985	2	5
IL18R1	INTERLEUKIN 18 RECEPTOR 1	NM_003855	NP_003846	3	2
ARG2	ARGINASE TYPE II	NM_001172	CAG38787	4	3
IL1RN	INTERLEUKIN-1 RECEPTOR ANTAGONIST GENE	NM_000577, NM_173841, NM_173842, NM_173843	AAN87150	4	4
TNFSF13B	TUMOR NECROSIS FACTOR (LIGAND) SUPERFAMILY, MEMBER 13B	NM_006573	NP_006564	4	5
ITGAM	INTEGRIN, ALPHA M (COMPLEMENT COMPONENT RECEPTOR 3, ALPHA; ALSO KNOWN AS CD11B (P170), MACROPHAGE ANTIGEN ALPHA POLYPEPTIDE)	NM_000632	NP_000623	5	7
CD4	CD4 ANTIGEN (P55)	NM_000616	NP_000607	6	7
TGFBI	TRANSFORMING GROWTH FACTOR, BETA-1 (TRANSFORMING GROWTH FACTOR, BETA-INDUCED, 68 KDA)	NM_000358	NP_000349	6	9
CD86	CD86 ANTIGEN (CD28 ANTIGEN LIGAND 2, B7-2 ANTIGEN)	NM_006889 NM_175862	NP_008820 NP_787058	6	6
TLR4	TOLL-LIKE RECEPTOR 4	AH009665	AAF05316	6	6
IFI16	INTERFERON, GAMMA-INDUCIBLE PROTEIN 16	NM_005531	AAH17059	6	9
ICAM1	INTERCELLULAR ADHESION MOLECULE 1	NM_010493	NP_000192, AAQ14902, AAQ14901	6	10
TGFBR2	TRANSFORMING GROWTH FACTOR, BETA RECEPTOR II	NM_003242	AAF27281	6	8
PLA2G7	PLATELET-ACTIVATING FACTOR ACETYLDHYDROLASE	NM_005084	CAH73907	7	6
IL-10	INTERLEUKIN 10	NM_000572	CAH73907	8	7

[0583] As Table 48 indicates, in general, important biomarkers at T₋₁₂ were also important biomarkers at earlier time points. The ten biomarkers that are italicized in Table 48 were carried forward to confirmation as described in Section 6.12. 1, below. CD4 was excluded in this embodiment because it was found to be different on day of entry.

6.11.2 Discovery Affymetrix Gene Chip Analysis

[0584] The patients were also analyzed using Affymetrix gene chip analysis. Such an analysis is described in Section 6.2 Biomarkers in multiple samples were measured by

[0585] Affymetrix gene chip analysis at multiple time points and analyzed in several different ways: static time of entry, static T₋₆₀, static T₋₃₆, baseline T₋₆₀, baseline T₋₃₆, and baseline T₋₁₂ data points. The Affymetrix gene chip assay is described in Section 6.2, above. Representative of these analyses is the static T₋₁₂ data analysis described in detail below. In the T₋₁₂ static analysis, biomarkers features were measured using a specific blood sample, designated the T₋₁₂ blood sample, as defined in Section 6.4, above.

[0586] For the T₋₁₂ static analysis, there were 54,613 biomarkers measured on 90 samples. Each sample was collected from a different member the population. Of these features, 31,047 were transformed by log transformations, 2518 by square root transformations and the remaining 21,048 were not transformed.

[0587] The 90 member population was initially split into a training set (n=69) and a validation set (n=21). The training set was used to estimate the appropriate classification algorithm parameters while the trained algorithm was applied to the validation set to independently assess performance. Of the 69 training samples, 34 were labeled Sepsis, meaning that the subjects developed sepsis at some point during the observation time period, and 35 were SIRS, meaning that they did not develop sepsis during the observation time period. Table 49 provides distributions of the race, gender and age for these samples.

TABLE 49

Distributions of the race, gender, and age for the training data				
Group	Gender	Black	Caucasian	Other
Sepsis	Male	9	13	1
	Female	0	10	1
SIRS	Male	5	20	0
	Female	0	10	0
Group	Minimum	Mean	Median	Maximum
Sepsis	18	44.1	39	80
SIRS	18	44.1	40	90

[0588] For the 21 validation samples, 11 were labeled Sepsis and 10 were labeled SIRS. Table 50 provides distributions of the race, gender and age for these samples.

TABLE 50

Distributions of the race, gender, and age for the validation data				
Group	Gender	Black	Caucasian	Other
Sepsis	Male	0	7	0
	Female	0	3	0

TABLE 50-continued

Distributions of the race, gender, and age for the validation data				
SIRS	Male	2	6	0
	Female	0	3	0
Group	Minimum	Mean	Median	Maximum
Sepsis	18	43.4	40	81
SIRS	19	53	52	85

[0589] Each sample in the training data was randomly assigned to one of ten groups used for cross-validation. The number of training samples in these groups ranged from 6 to 8. The samples were assigned in way that attempted to balance the number of sepsis and SIRS samples across folds. As described in more detail below, several different methods were used to judge whether select biomarkers discriminate between the Sepsis and SIRS groups.

[0590] Wilcoxon and Q-value tests. The first method used to identify discriminating biomarkers was a Wilcoxon test (unadjusted). The abundance value for a given biomarker across the samples in the training data was subjected to the Wilcoxon test. The Wilcoxon test considers both group classification (sepsis versus SIRS) and abundance value in order to compute a p value for the given biomarker. The p value provides an indication of how well the abundance value for the given biomarker across the samples collected in the training set discriminates between the sepsis and SIRS state. The lower the p value, the better the discrimination. When the p value is less than a specific confidence level, such as 0.05, an inference is made that the biomarker discriminates between the sepsis and SIRS phenotype. There were 19791 significant biomarkers using this method (see Table 51).

[0591] The second method used to identify discriminating biomarkers was the Wilcoxon Test (adjusted). Due to the large number of biomarkers, 54613, and the relatively small number of samples, 90, there was a high risk of finding falsely significant biomarkers. An adjusted p-value was used to counter this risk. In particular, the method of Benjamini and Hochberg, 1995, J.R. Statist. Soc. B 57, pp 289-300, which is hereby incorporated herein by reference in its entirety, was used to control the false discovery rate. Here, the false discovery rate is defined as the number of biomarkers truly significant divided by the number of biomarkers declared significant. For example, if the adjusted p value is less than 0.05, there is a 5% chance that the biomarker is a false discovery. Results using this test are reported in Table 51. There were 11851 significant biomarkers using this method (see Table 51). As used, herein, a biomarker is considered significant if it has a p-value of less than 0.05 as determined by the Wilcoxon test (adjusted).

[0592] The third method used to identify discriminating biomarkers was the use of Q values. In such an approach, the biomarkers are ordered by their q-values and if a respective biomarker has a Q value of X, then respective biomarker and all others more significant have a combined false discovery rate of X. However, the false discovery rate for any one biomarker may be much larger. There were 11581 significant biomarkers using this method (see Table 51).

TABLE 51

Cumulative number of significant calls for the three methods. Note that all 96 samples (training and validation) were used to compare Sepsis and SIRS groups. Missing biomarker feature values were not included in the analyses.

	$\leq 1e-04$	≤ 0.001	≤ 0.01	≤ 0.025	≤ 0.05	≤ 0.1	≤ 1
p-value (unadjusted)	0	5417	11537	15769	19791	24809	54613
p-value (adjusted)	0	0	5043	8374	11851	16973	54613
q-value	0	0	7734	12478	17820	24890	54613

[0593] CART. In addition to analyzing the microarray data using Wilcoxon and Q-value tests in order to identify biomarkers that discriminate between the sepsis and SIRS sub-populations in the training set, classification and regression tree (CART) analysis was used. CART is described in Section 5.5.1, above. Specifically, the data summarized above was used to predict the disease state by iteratively partitioning the data based on the best single-variable split of the data. In other words, at each stage of the tree building process, the biomarker whose expression values across the training population best discriminate between the sepsis and SIRS population was invoked as a decision branch. Cross-validation was carried out, with the optimal number of splits estimated independently in each of the 10 iterations. The final tree uses four probesets: X214681_at, X230281_at, X1007_s_at, and X1560432_at, where each given probeset is the U133 plus 2.0 Affymetrix probe set name. The confusion matrix for the training data, based on the final tree from the cross-validated CART algorithm is given in Table 52. From this confusion matrix, the overall accuracy was estimated to be 65.2% with a 95% confidence interval of 52.8% to 76.3%. The estimated sensitivity was 61.8% and the estimated specificity was 68.6%.

TABLE 52

Confusion matrix for training samples using the cross-validated CART algorithm

Predicted	True Diagnosis	
	Sepsis	SIRS
Sepsis	21	11
SIRS	13	24

[0594] For the 21 validation samples held back from training data set, the overall accuracy was estimated to be 71.4% with a 95% confidence interval of 47.8% to 88.7%, sensitivity 90.9% and specificity 50%. The confusion matrix for the validation samples was predicted Sepsis/true Sepsis 10, predicted SIRS/true Sepsis 1, predicted Sepsis/true SIRS 5, predicted SIRS/true SIRS 5.

[0595] Random Forests. Another decision rule that can be developed using biomarkers of the present invention is a Random Forests decision tree. Random Forests is a tree based method that uses bootstrapping instead of cross-validation. For each iteration, a random sample (with replacement) is drawn and the largest tree possible is grown. Each tree receives a vote in the final class prediction. To fit a random forest, the number of trees (e.g. bootstrap iterations) is specified. No more than 500 were used in this example, but at least 50 are needed for a burn-in period. The number of trees was

chosen based on the accuracy of the training data. For this data, 439 trees were used to train the algorithm. Using this algorithm, 845 biomarkers had non-zero importance and were used in the model. The random forest algorithm gauges biomarker importance by the average reduction in the training accuracy.

[0596] The random forest method uses a number of different decision trees. A biomarker is considered to have discriminating significance if it served as a decision branch of a decision tree from a significant random forest analysis. As used herein, a significant random forest analysis is one where the lower 95% confidence interval on accuracy by cross validation on a training data set is greater than 50% and the point estimate for accuracy on a validation set is greater than 65%.

[0597] The predicted confusion matrix for the training dataset using the decision tree developed using the Random Forest method is given in Table 53. From this confusion matrix, the overall accuracy was estimated to be 75.4% (confidence intervals cannot be computed when using the bootstrap accuracy estimate). The estimated sensitivity was 73.5% and the estimated specificity was 77.1%.

TABLE 53

Confusion matrix for training samples against the decision tree developed using the Random Forest method.

Predicted	True Diagnosis	
	Sepsis	SIRS
Sepsis	27	9
SIRS	8	25

[0598] For the 21 validation samples held back from training, the overall accuracy was estimated to be 76.2% with a 95% confidence interval of 76.2% to 99.9%, sensitivity 100% and specificity 90%. Table 54 shows the confusion matrix for the validation samples.

TABLE 54

Confusion matrix for the validation samples against the decision tree developed using the Random Forest method.

Predicted	True Diagnosis	
	Sepsis	SIRS
Sepsis	11	1
SIRS	0	9

[0599] MART. Multiple Additive Regression Trees (MART), also known as “gradient boosting machines,” was

used to simultaneously assess the importance of biomarkers and classify the subject samples. Several fitting parameters are specified in this approach including (i) number of trees, (ii) step size (commonly referred to as “shrinkage”), and (iii) degree of interaction (related to the number of splits for each tree). More information on MART is described in Section 5.5.4 above. The degree of interaction was set to 1 to enforce an additive model (e.g. each tree has one split and only uses one biomarker).

[0600] Estimating interactions may require more data to function well. The step size was set to 0.05 so that the model complexity was dictated by the number of trees. The optimal number of trees was estimated by leaving out a random subset of cases at each fitting iteration, then assessing quality of prediction on that subset. After fitting more trees than were warranted, the point at which prediction performance stopped improving was estimated as the optimal point.

[0601] The estimated model used 28 trees and 17 biomarkers across all trees. The MART algorithm also provides a calculation of biomarker importance (summing to 100%). Biomarkers ranked in decreasing order of importance to the model, with the most important biomarker first were: X206513_at, X214681_at, X235359_at, X221850_x_at, X213524_s_at, X225656_a, X200881_s_at, X229743_at, X215178_x_at, X215178_x_at, X216841_s_at, X216841_at, X244158_at, X238858_at, X205287_s_at, X233651_s_at, X229572_at, X214765_s_at.

[0602] Cross-validation was carried out, with the optimal number of trees estimated independently in each of the 10 iterations. The confusion matrix for the training data where the predicted classifications were made from the cross-validated model is given in Table 55. From this confusion matrix, the overall accuracy was estimated to be 76.8% with a 95% confidence interval of 65.1% to 86.1%. The estimated sensitivity was 76.5% and the estimated specificity was 77.1%.

TABLE 55

Confusion matrix for the training samples using the cross-validated MART algorithm.		
Predicted	True Diagnosis	
	Sepsis	SIRS
Sepsis	26	8
SIRS	8	27

[0603] For the 21 validation samples held back from training, the overall accuracy was estimated to be 85.7% with a 95% confidence interval of 63.7% to 97%, sensitivity 80% and specificity 90.9%. Table 56 shows the confusion matrix for the validation samples.

TABLE 56

Confusion matrix for the validation samples using the MART algorithm.		
Predicted	True Diagnosis	
	Sepsis	SIRS
Sepsis	8	1
SIRS	2	10

[0604] PAM. Yet another decision rule developed using biomarkers of the present invention is predictive analysis of microarrays (PAM), which is described in Section 5.5.2, above. In this method, a shrinkage parameter that determines the number of biomarkers used to classify samples is specified. This parameter was chosen via cross-validation. There were no biomarkers with missing values. Based on cross-validation, the optimal threshold value was 2.1, corresponding to 820 biomarkers.

[0605] Using the threshold of 2.1, the overall accuracy for the training samples was estimated to be 80.9% with a 95% confidence interval of 73.4% to 86.7%. The estimated sensitivity was 85.7% and the estimated specificity was 76.5%. Table 57 shows the confusion matrix for the training data where the predicted classifications were made from the cross-validated models.

TABLE 57

Confusion matrix for training samples using cross-validated PAM algorithm		
Predicted	True Diagnosis	
	Sepsis	SIRS
Sepsis	11	1
SIRS	0	9

[0606] For the 21 validation samples held back from training, the overall accuracy was estimated to be 95.2% with a 95% confidence interval of 76.2% to 99.9%, sensitivity 100% and specificity 90%. Table 58 shows the confusion matrix for the validation samples.

TABLE 58

Confusion matrix for validation samples using cross-validated PAM algorithm		
Predicted	True Diagnosis	
	Sepsis	SIRS
Sepsis	11	1
SIRS	0	9

[0607] The top ten biomarkers identified by PAM, ranked from most important to

[0608] least important were: X206513_at, X213524_s_at, X200881_s_at, X218992_at, X238858_at, X221123_x_at, X228402_at, X230585_at, X209304_x_at, X214681_at.

[0609] FIG. 46 provides a summary of the CART, MART, PAM, and random forests (RF) classification algorithm (decision rule) performance and associated 95% confidence intervals using T₁₂ static data obtained from an Affymetrix gene chip discovery training population. Fifty distinct biomarkers were selected from across all the algorithms illustrated in FIG. 46. The identity of the top 50 biomarkers, ranked from most to least significant is: X204102_s_at, X236013_at, X213668_s_at, X1556639_at, X218220_at, X207860_at, X232422_at, X218578_at, X205875_s_at, X226043_at, X225879_at, X224618_at, X216316_x_at, X243159_x_at, X202200_s_at, X201936_s_at, X242492_at, X216609_at, X214328_s_at, X228648_at, X223797_at, X225622_at,

X205988_at, X201978_s_at, X200874_s_at, X210105_s_at, X203913_s_at, X204225_at, X227587_at, X220865_s_at, X206682_at, X222664_at, X212264_s_at, X219669_at, X221971_x_at, X1554464_a_at, X242590_at, X227925_at, X221926_s_at, X202101_s_at, X211078_s_at, X44563_at, X206513_at, X215178_x_at, X235359_at, X225656_at, X244158_at, X214765_s_at, X229743_at, X214681.

[0610] From the analysis of the T₁₂ data set and the other data sets, the 34 biomarkers indicated in Table 59 below were selected for confirmation. As indicated in Table 59, biomarkers were selected based on the Affymetrix gene chip analysis for one of three criteria, biological relevance (BR), high fold change (HF), or statistical importance (SI) in the Affymetrix gene chip analysis.

TABLE 59

Nucleic acid based biomarkers selected for confirmation from Affymetrix Assay				
Gene Symbol	Gene Name	Gene Accession Number	Protein Accession Number	Selection Criterion
BCL2A1	BCL2-RELATED PROTEIN A1	NM_004049	NP_004040	BR
CCL5	CHEMOKINE (C-C MOTIF) LIGAND 5	NM_002985	NP_002976	BR
CSF1R	COLONY STIMULATING FACTOR 1 RECEPTOR, FORMERLY MCDONOUGH FELINE SARCOMA VIRAL (V-FMS) ONCOGENE HOMOLOG	NM_005211	NP_005202	BR
GADD45A	GROWTH ARREST AND DNA-DAMAGE-INDUCIBLE, ALPHA	NM_001924	NP_001915	BR
GADD45B	GROWTH ARREST- AND DNA DAMAGE-INDUCIBLE GENE GADD45	NM_015675	NP_056490	BR
IFNGR1	INTERFERON GAMMA RECEPTOR I	NM_000416	NP_000407	BR
IL10RA	INTERLEUKIN 10 RECEPTOR, ALPHA	NM_001558	NP_001549	BR
IRAK2	INTERLEUKIN-1 RECEPTOR-ASSOCIATED KINASE 2	NM_001570	NP_001561	BR
IRAK4	INTERLEUKIN-1 RECEPTOR-ASSOCIATED KINASE 4	NM_016123	NP_057207	BR
JAK2	JANUS KINASE 2 (A PROTEIN TYROSINE KINASE)	NM_004972	NP_004963	BR
LY96	LYMPHOCYTE ANTIGEN 96	NM_015364	NP_056179	BR
MAP2K6	MITOGEN-ACTIVATED PROTEIN KINASE KINASE 6	NM_002758	NP_002749	BR
MAPK14	MAPK14 MITOGEN-ACTIVATED PROTEIN KINASE 14	NM_031988	NP_114365	BR
		NM_001315	NP_001306	BR
		NM_139012	NP_620581	BR
		NM_139013	NP_620582	BR
		NM_139014	NP_620583	BR
MKMK1	MAP KINASE INTERACTING SERINE/THREONINE KINASE 1	NM_003684	NP_003675	BR
		NM_198973	NP_945324	BR
OSM	ONCOSTATIN M	NM_020530	NP_065391	BR
SOCS3	SUPPRESSOR OF CYTOKINE SIGNALING 3	NM_003955	NP_003946	BR
TDRD9	TUDOR DOMAIN CONTAINING 9	NM_153046	NP_694591	BR
TNFRSF6	TUMOR NECROSIS FACTOR RECEPTOR SUPERFAMILY, MEMBER 6	NM_152877	NP_000034	BR
TNFSF10	TUMOR NECROSIS FACTOR (LIGAND) SUPERFAMILY, MEMBER 10	NM_003810	NP_003801	BR
ANKRD22	ANKYRIN REPEAT DOMAIN 22	NM_144590	NP_653191	HF
ANXA3	ANNEXIN A3	NM_005139	NP_005130	HF
CEACAM1	CARCINOEMBRYONIC ANTIGEN-RELATED CELL ADHESION MOLECULE 1	NM_001712	NP_001703	HF
LDLR	LOW DENSITY LIPOPROTEIN RECEPTOR	NM_000527	NP_000518	HF

TABLE 59-continued

Nucleic acid based biomarkers selected for confirmation from Affymetrix Assay				
Gene Symbol	Gene Name	Gene Accession Number	Protein Accession Number	Selection Criterion
PFKFB3	6-PHOSPHOFRUCTO-2-KINASE/FRUCTOSE-2,6-BISPHOSPHATASE 3	NM_004566	NP_004557	HF
PRV1	NEUTROPHIL-SPECIFIC ANTIGEN 1 (POLYCYTHEMIA RUBRA VERA 1)	NM_020406	NP_065139	HF
PSTPIP2	PROLINE/SERINE/THREONINE PHOSPHATASE-INTERACTING PROTEIN 1 (PROLINE-SERINE-THREONINE PHOSPHATASE INTERACTING PROTEIN 2)	NM_024430	NP_077748	HF
TIFA	TRAF-INTERACTING PROTEIN WITH A FORKHEAD-ASSOCIATED DOMAIN	NM_052864	NP_443096	HF
VNN1	VANIN 1	NM_004666	NP004657	HF
NCR1	NATURAL CYTOTOXICITY TRIGGERING RECEPTOR 1	NM_004829	NP_004820	SI
FAD104	FIBRONECTIN TYPE III DOMAIN CONTAINING 3B (FNDC3B)	NM_022763	NP_073600	SI
INSL3	INSULIN-LIKE 3 (LEYDIG CELL)	NM_005543	NP_005534	SI
CRTAP	CARTILAGE-ASSOCIATED PROTEIN	NM_006371	NP_006362	SI
HLA-DRA	MAJOR HISTOCOMPATIBILITY COMPLEX, CLASS II, DR ALPHA	NM_002123	NP_002114	SI
SOD2	SUPEROXIDE DISMUTASE 2, MITOCHONDRIAL	NM_000636	NP_000627	SI

6.12 Confirmation of Select Nucleic Acid Biomarkers

[0611] In this example, a confirmatory process was performed in order to confirm which biomarkers differentiate between patients who subsequently develop sepsis (“sepsis patients”) and patients who do not (“SIRS patients”).

6.12.1 Confirmatory Analysis of Biomarkers Identified by RT-PCR

[0612] The biomarkers identified by italicizes in Table 48 of Section 6.11.1, namely FCGR1A, MMP9, IL18R1, ARG2, IL1RN, TNFSF13B, ITGAM, TGFB1, CD86, and TLR4, were analyzed using RT-PCR at multiple time points and analyzed in several different ways: static time of entry, static T₋₆₀, static T₋₃₆, baseline T₋₆₀, baseline T₋₃₆, and baseline T₋₁₂ data points. RT-PCR is described in Section 5.4.1.2, above. Representative of these analyses is the static T₋₁₂ data analysis described in detail below. In the T₋₁₂ static analysis, biomarkers features were measured using a specific blood sample, designated the T₋₁₂ blood sample, as defined in Section 6.4, above.

[0613] For the T₋₁₂ static analysis, the biomarkers FCGR1A, MMP9, IL18R1, ARG2, IL1RN, TNFSF13B, ITGAM, TGFB1, CD86, and TLR4, were measured from 50 samples. Each sample was collected from a different member

of the population. Of these biomarkers, seven were transformed by log transformations, and three by square root transformations.

[0614] The 50 member population was initially split into a training set (n=39) and a validation set (n=11). The training set was used to estimate the appropriate classification algorithm parameters while the trained algorithm was applied to the validation set to independently assess performance. Of the 50 training samples, 23 were labeled Sepsis, meaning that the subjects developed sepsis at some point during the observation time period, and 16 were SIRS, meaning that they did not develop sepsis during the observation time period. Table 60 provides distributions of the race, gender and age for these samples.

TABLE 60

Distributions of the race, gender, and age for the training data				
Group	Gender	Black	Caucasian	Other
Sepsis	Male	3	13	0
	Female	0	7	0
SIRS	Male	5	7	1
	Female	0	2	0

TABLE 60-continued

Distributions of the race, gender, and age for the training data				
Group	Minimum	Mean	Median	Maximum
Sepsis	20	52.3	56	80
SIRS	20	39.9	32.5	79

[0615] For the 11 validation samples, five were labeled Sepsis and six were labeled SIRS. Table 61 provides distributions of the race, gender and age for these samples.

TABLE 61

Distributions of the race, gender, and age for the validation data				
Group	Gender	Black	Caucasian	Other
Sepsis	Male	2	1	0
	Female	0	3	0
SIRS	Male	0	3	0
	Female	0	2	0

Group	Minimum	Mean	Median	Maximum
Sepsis	18	51.7	59.5	76
SIRS	24	47.2	43	76

[0616] Each sample in the training data was randomly assigned to one of ten groups used for cross-validation. The number of training samples in these groups ranged from three to five. The samples were assigned in way that attempted to balance the number of sepsis and SIRS samples across folds. As described in more detail below, several different methods were used to judge whether select biomarkers discriminate between the Sepsis and SIRS groups.

[0617] Wilcoxon and Q-value tests. The first method used to identify discriminating biomarkers was a Wilcoxon test (unadjusted). The abundance value for a given biomarker across the samples in the training data was subjected to the Wilcoxon test. The Wilcoxon test considers both group classification (sepsis versus SIRS) and abundance value in order to compute a p value for the given biomarker. The p value provides an indication of how well the abundance value for the given biomarker across the samples collected in the training set discriminates between the sepsis and SIRS state. The lower the p value, the better the discrimination. When the p value is less than a specific confidence level, such as 0.05, an inference is made that the biomarker discriminates between the sepsis and SIRS phenotype. There were nine significant biomarkers using this method (see Table 62).

[0618] The second method used to identify discriminating biomarkers was the Wilcoxon Test (adjusted). Due to the large number of biomarkers, 10, and the relatively small number of samples, 50, there was a high risk of finding falsely significant biomarkers. An adjusted p value was used to counter this risk. In particular, the method of Benjamini and Hochberg, 1995, J.R. Statist. Soc. B 57, pp 289-300, which is hereby incorporated herein by reference in its entirety, was used to control the false discovery rate. Here, the false discovery rate is defined as the number of biomarkers truly significant divided by the number of biomarkers declared significant. For example, if the adjusted p value is less than

0.05, there is a 5% chance that the biomarker is a false discovery. Results using this test are reported in Table 62. There were nine significant biomarkers using this method (see Table 62). As used, herein, a biomarker is considered significant if it has a p value of less than 0.05 as determined by the Wilcoxon test (adjusted).

[0619] The third method used to identify discriminating biomarkers was the use of Q values. In such an approach, the biomarkers are ordered by their Q values and if a respective biomarker has a Q value of X, then respective biomarker and all others more significant have a combined false discovery rate of X. However, the false discovery rate for any one biomarker may be much larger. There were nine significant biomarkers using this method (see Table 62).

TABLE 62

Cumulative number of significant calls for the three methods. Note that all samples (training and validation) were used to compare Sepsis and SIRS groups. Missing biomarker feature values were not included in the analyses.							
	≤1e-04	≤0.001	≤0.01	≤0.025	≤0.05	≤0.1	≤1
p-value (unadjusted)	0	7	9	9	9	9	10
p-value (adjusted)	0	7	9	9	9	9	10
q-value	0	0	0	0	0	0	10

[0620] CART. In addition to analyzing the microarray data using Wilcoxon and Q-value tests in order to identify biomarkers that discriminate between the sepsis and SIRS subpopulations in the training set, classification and regression tree (CART) analysis was used. CART is described in Section 5.5.1, above. Specifically, the data summarized above was used to predict the disease state by iteratively partitioning the data based on the best single-variable split of the data. In other words, at each stage of the tree building process, the biomarker whose expression values across the training population best discriminate between the sepsis and SIRS population was invoked as a decision branch. Cross-validation was carried out, with the optimal number of splits estimated independently in each of the 10 iterations. The final tree uses three biomarkers which are listed in order of importance IL18R1, ARG2, and FCGR1A, where IL18R1 was the most important. The confusion matrix for the training data, based on the final tree from the cross-validated CART algorithm is given in Table 63. From this confusion matrix, the overall accuracy was estimated to be 82.1% with a 95% confidence interval of 66.5% to 92.5%. The estimated sensitivity was 82.6% and the estimated specificity was 81.2%.

TABLE 63

Confusion matrix for training samples using the cross-validated CART algorithm		
Predicted	True Diagnosis	
	Sepsis	SIRS
Sepsis	19	3
SIRS	4	13

[0621] For the 11 validation samples held back from training data set, the overall accuracy was estimated to be 100% with a 95% confidence interval of 71.5% to 100%, sensitivity 100% and specificity 100%. Table 64 shows the confusion matrix for the validation samples.

TABLE 64

Confusion matrix for validation samples using the cross-validated CART algorithm		
Predicted	True Diagnosis	
	Sepsis	SIRS
Sepsis	5	0
SIRS	0	6

[0622] Random Forests. Another decision rule that can be developed using biomarkers of the present invention is a Random Forests decision tree. Random Forests is a tree based method that uses bootstrapping instead of cross-validation. For each iteration, a random sample (with replacement) is drawn and the largest tree possible is grown. Each tree receives a vote in the final class prediction. To fit a random forest, the number of trees (e.g. bootstrap iterations) is specified. For this data, 1000 trees were used to train the algorithm. Using this algorithm, 9 of the 10 biomarkers had non-zero importance and were used in the model. Biomarker importance, from greatest to smallest, was: TGFB1, MMP9, TLR4, IL1RN, TNFSF, ARG2, FCGR1A, and IL18R1.

[0623] The random forest method uses a number of different decision trees. A biomarker is considered to have discriminating significance if it served as a decision branch of a decision tree from a significant random forest analysis. As used herein, a significant random forest analysis is one where the lower 95% confidence interval on accuracy by cross validation on a training data set is greater than 50% and the point estimate for accuracy on a validation set is greater than 65%.

[0624] The predicted confusion matrix for the training dataset using the decision tree developed using the Random Forest method is given in Table 65. From this confusion matrix, the overall accuracy was estimated to be 79.5% with a 95% confidence interval between 63.5% and 90.7%. The estimated sensitivity was 87% and the estimated specificity was 68.8%.

TABLE 65

Confusion matrix for training samples against the decision tree developed using the Random Forest method.		
Predicted	True Diagnosis	
	Sepsis	SIRS
Sepsis	20	5
SIRS	3	11

[0625] For the 11 validation samples held back from training, the overall accuracy was estimated to be 81.8% with a 95% confidence interval of 48.2% to 97.7%, sensitivity 60% and specificity 100%. Table 66 shows the confusion matrix for the validation samples.

TABLE 66

Confusion matrix for the 11 validation samples against the decision tree developed using the Random Forest method.		
Predicted	True Diagnosis	
	Sepsis	SIRS
Sepsis	6	0
SIRS	2	3

[0626] MART. Multiple Additive Regression Trees (MART), also known as “gradient boosting machines,” was used to simultaneously assess the importance of biomarkers and classify the subject samples. Several fitting parameters are specified in this approach including (i) number of trees, (ii) step size (commonly referred to as “shrinkage”), and (iii) degree of interaction (related to the number of splits for each tree). More information on MART is described in Section 5.5.4 above. The degree of interaction was set to 1 to enforce an additive model (e.g. each tree has one split and only uses one biomarker).

[0627] Estimating interactions may require more data to function well. The step size was set to 0.05 so that the model complexity was dictated by the number of trees. The optimal number of trees was estimated by leaving out a random subset of cases at each fitting iteration, then assessing quality of prediction on that subset. After fitting more trees than were warranted, the point at which prediction performance stopped improving was estimated as the optimal point.

[0628] The estimated model used 30 trees and 7 biomarkers across all trees. The MART algorithm also provides a calculation of biomarker importance (summing to 100%). Biomarkers ranked in decreasing order of importance to the model, with the most important biomarker first were: ITGAM, TGFB1, TLR4, TNFSF, FCGR1A, IL18R1, and ARG2.

[0629] Cross-validation was carried out, with the optimal number of trees estimated independently in each of the 10 iterations. The confusion matrix for the training data where the predicted classifications were made from the cross-validated model is given in Table 67. From this confusion matrix, the overall accuracy was estimated to be 74.4% with a 95% confidence interval of 57.9% to 87%. The estimated sensitivity was 73.8% and the estimated specificity was 68.8%.

TABLE 67

Confusion matrix for the training samples using the cross-validated MART algorithm.		
Predicted	True Diagnosis	
	Sepsis	SIRS
Sepsis	18	5
SIRS	5	11

[0630] For the 11 validation samples held back from training, the overall accuracy was estimated to be 74.4% with a 95% confidence interval of 57.9% to 87%, sensitivity 78.3% and specificity 68.8%. Table 68 shows the confusion matrix for the validation samples.

TABLE 68

Confusion matrix for the validation samples using the MART algorithm.		
Predicted	True Diagnosis	
	Sepsis	SIRS
Sepsis	6	2
SIRS	0	3

[0631] PAM. Yet another decision rule developed using biomarkers of the present invention is predictive analysis of microarrays (PAM), which is described in Section 5.5.2, above. In this method, a shrinkage parameter that determines the number of biomarkers used to classify samples is specified. This parameter was chosen via cross-validation.

There were no biomarkers with missing values. Based on cross-validation, the optimal threshold value was 0.55, corresponding to 9 biomarkers.

[0632] Using the threshold of 0.55, the overall accuracy for the training samples was estimated to be 82.3% with a 95% confidence interval of 68.8% to 90.7%. The estimated sensitivity was 68.8% and the estimated specificity was 91.3%. Table 69 shows the confusion matrix for the training data where the predicted classifications were made from the cross-validated models.

TABLE 69

Confusion matrix for training samples using cross-validated PAM algorithm		
Predicted	True Diagnosis	
	Sepsis	SIRS
Sepsis	11	2
SIRS	5	21

[0633] For the 11 validation samples held back from training, the overall accuracy was estimated to be 72.67% with a 95% confidence interval of 39% to 94%, sensitivity 40% and specificity 100%. Table 70 shows the confusion matrix for the validation samples.

TABLE 70

Confusion matrix for validation samples using cross-validated PAM algorithm		
Predicted	True Diagnosis	
	Sepsis	SIRS
Sepsis	2	0
SIRS	3	6

[0634] The top nine biomarkers identified by PAM, ranked from most important to least important were: ARG2, TGFB1, MMP9, TLR4, ITGAM, IL18R1, TNFSF, IL1RN, and FCGR1A. FIG. 47 provides a summary of the CART, MART, PAM, and random forests (RF) classification algorithm (decision rule) performance and associated 95% confidence intervals using T₋₁₂ static data obtained from an Affymetrix gene chip confirmatory training population. Based on the results of the RT-PCR analysis summarized in FIG. 47 and at other time

points, all ten biomarkers under study in this confirmation process were significant. Some of the biomarkers discriminated as early as T₋₆₀.

6.12.2 Confirmatory Analysis of Biomarkers Identified by Affymetrix Gene Chip Analysis

[0635] The biomarkers identified in Table 59 of Section 6.11.2 and the ten biomarkers identified in Table 48 of Section 6.11.1 (FCGR1A, MMP9, IL18R1, ARG2, IL1RN, TNFSF13B, ITGAM, TGFB1, CD86, and TLR4), a total of 44 biomarkers, were analyzed using RT-PCR at multiple time points and analyzed in several different ways: static time of entry, static T₋₆₀, static T₋₃₆, baseline T₋₆₀, baseline T₋₃₆, and baseline T₋₁₂ data points. RT-PCR is described in Section 5.4.1.2, above. Representative of these analyses is the static T₋₁₂ data analysis described in detail below. In the T₋₁₂ static analysis, biomarkers features were measured using a specific blood sample, designated the T₋₁₂ blood sample, as defined in Section 6.4, above.

[0636] For the T₋₁₂ static analysis, the 44 biomarkers were measured from 37 samples. Each sample was collected from a different member of the population. Of these biomarkers, 23 were transformed by log transformations, and 21 by square root transformations.

[0637] The 37 member population was initially split into a training set (n=28) and a validation set (n=9). The training set was used to estimate the appropriate classification algorithm parameters while the trained algorithm was applied to the validation set to independently assess performance. Of the 28 training samples, 14 were labeled Sepsis, meaning that the subjects developed sepsis at some point during the observation time period, and 14 were SIRS, meaning that they did not develop sepsis during the observation time period. Table 71 provides distributions of the race, gender and age for these samples.

TABLE 71

Distributions of the race, gender, and age for the training data				
Group	Gender	Black	Caucasian	Other
Sepsis	Male	1	7	0
	Female	0	6	0
SIRS	Male	4	6	1
	Female	0	2	0
Group	Minimum	Mean	Median	Maximum
Sepsis	28	58	56	76
SIRS	20	42.5	39.5	79

[0638] For the 9 validation samples, five were labeled Sepsis and four were labeled SIRS. Table 72 provides distributions of the race, gender and age for these samples.

TABLE 72

Distributions of the race, gender, and age for the validation data				
Group	Gender	Black	Caucasian	Other
Sepsis	Male	2	0	0
	Female	0	3	0
SIRS	Male	0	2	0
	Female	0	2	0

TABLE 72-continued

Distributions of the race, gender, and age for the validation data				
Group	Minimum	Mean	Median	Maximum
Sepsis	18	49.8	58	76
SIRS	24	45.8	41.5	76

[0639] Each sample in the training data was randomly assigned to one of ten groups used for cross-validation. The number of training samples in these groups ranged from two to four. The samples were assigned in way that attempted to balance the number of sepsis and SIRS samples across folds. As described in more detail below, several different methods were used to judge whether select biomarkers discriminate between the Sepsis and SIRS groups.

[0640] Wilcoxon and Q-value tests. The first method used to identify discriminating biomarkers was a Wilcoxon test (unadjusted). The abundance value for a given biomarker across the samples in the training data was subjected to the Wilcoxon test. The Wilcoxon test considers both group classification (sepsis versus SIRS) and abundance value in order to compute a p value for the given biomarker. The p value provides an indication of how well the abundance value for the given biomarker across the samples collected in the training set discriminates between the sepsis and SIRS state. The lower the p value, the better the discrimination. When the p value is less than a specific confidence level, such as 0.05, an inference is made that the biomarker discriminates between the sepsis and SIRS phenotype. There were 38 significant biomarkers using this method (see Table 73).

[0641] The second method used to identify discriminating biomarkers was the Wilcoxon Test (adjusted). Due to the large number of biomarkers, 44, and the relatively small number of samples, 37, there was a high risk of finding falsely significant biomarkers. An adjusted p value was used to counter this risk. In particular, the method of Benjamini and Hochberg, 1995, J.R. Statist. Soc. B 57, pp 289-300, which is hereby incorporated herein by reference in its entirety, was used to control the false discovery rate. Here, the false discovery rate is defined as the number of biomarkers truly significant divided by the number of biomarkers declared significant. For example, if the adjusted p value is less than 0.05, there is a five percent chance that the biomarker is a false discovery. Results using this test are reported in Table 73. There were 38 significant biomarkers using this method (see Table 73). As used, herein, a biomarker is considered significant if it has a p value of less than 0.05 as determined by the Wilcoxon test (adjusted).

[0642] The third method used to identify discriminating biomarkers was Q values. In this third approach, the biomarkers were ordered by their Q values and if a respective biomarker has a Q value of X, then respective biomarker and all others more significant have a combined false discovery rate of X. However, the false discovery rate for any one biomarker may be much larger. There were 38 significant biomarkers using this method (see Table 73).

TABLE 73

Cumulative number of significant calls for the three methods. Note that all samples (training and validation) were used to compare sepsis and SIRS groups. Missing biomarker feature values were not included in the analyses.							
	$\leq 1e-04$	≤ 0.001	≤ 0.01	≤ 0.025	≤ 0.05	≤ 0.1	≤ 1
p-value (unadjusted)	0	27	38	38	38	38	44
p-value (adjusted)	0	23	38	38	38	38	44
q-value	0	36	38	39	39	39	44

[0643] CART. In addition to analyzing the microarray data using Wilcoxon and Q-value tests in order to identify biomarkers that discriminate between the sepsis and SIRS sub-populations in the training set, classification and regression tree (CART) analysis was used. CART is described in Section 5.5.1, above. Specifically, the data summarized above was used to predict the disease state by iteratively partitioning the data based on the best single-variable split of the data. In other words, at each stage of the tree building process, the biomarker whose expression values across the training population best discriminate between the sepsis and SIRS population was invoked as a decision branch. Cross-validation was carried out with the optimal number of splits estimated independently in each of the 10 iterations. The final tree uses three biomarkers which are listed in order of importance OSM, HLA-DRA, and IL-18, where OSM was the most important. The confusion matrix for the training data, based on the final tree from the cross-validated CART algorithm is given in Table 74. From this confusion matrix, the overall accuracy was estimated to be 67.9% with a 95% confidence interval of 47.6% to 84.1%. The estimated sensitivity was 64.3% and the estimated specificity was 71.4%.

TABLE 74

Confusion matrix for training samples using the cross-validated CART algorithm		
Predicted	True Diagnosis	
	Sepsis	SIRS
Sepsis	9	4
SIRS	5	10

[0644] For the 9 validation samples held back from training data set, the overall accuracy was estimated to be 88.9% with a 95% confidence interval of 51.8% to 99.7%, sensitivity 75% and specificity 100%. Table 75 shows the confusion matrix for the validation samples.

TABLE 75

Confusion matrix for validation samples using the cross-validated CART algorithm		
Predicted	True Diagnosis	
	Sepsis	SIRS
Sepsis	3	0
SIRS	1	5

[0645] Random Forests. Another decision rule that can be developed using biomarkers of the present invention is a Random Forests decision tree. Random Forests is a tree based method that uses bootstrapping instead of cross-validation. For each iteration, a random sample (with replacement) is drawn and the largest tree possible is grown. Each tree receives a vote in the final class prediction. To fit a random forest, the number of trees (e.g. bootstrap iterations) is specified. For this data, 1000 trees were used to train the algorithm. Using this algorithm, 35 of the 44 biomarkers had non-zero importance and were used in the model. Biomarker importance, from greatest to smallest, was: OSM, GADD45B, ARG2, IL18R1, TDRD9, PFKFB3, MAPK14, PRV1, MAP2K6, TNFRSF6, FCGR1A, INSL3, LY96, PSTPIP2, ANKRD22, TNFSF10, HLA-DRA, FNDC3B, TIFA, GADD45A, VNN1, ITGAM, BCL2A1, TLR4, TNFSF13B, SOCS3, IL1RN, CEACAM1, and SOD2.

[0646] The random forest method uses a number of different decision trees. A biomarker is considered to have discriminating significance if it served as a decision branch of a decision tree from a significant random forest analysis. As used herein, a significant random forest analysis is one where the lower 95% confidence interval on accuracy by cross validation on a training data set is greater than 50% and the point estimate for accuracy on a validation set is greater than 65%.

[0647] The predicted confusion matrix for the training dataset using the decision tree developed using the Random Forest method is given in Table 76. From this confusion matrix, the overall accuracy was estimated to be 78.6%. The estimated sensitivity was 78.6% and the estimated specificity was also 78.6%.

TABLE 76

Confusion matrix for training samples against the decision tree developed using the Random Forest method.		
Predicted	True Diagnosis	
	Sepsis	SIRS
Sepsis	11	3
SIRS	3	11

[0648] For the 9 validation samples held back from training, the overall accuracy was estimated to be 77.8% with a 95% confidence interval of 40.0% to 97.2%, sensitivity 50% and specificity 100%. Table 77 shows the confusion matrix for the validation samples.

TABLE 77

Confusion matrix for validation samples against the decision tree developed using the Random Forest method.		
Predicted	True Diagnosis	
	Sepsis	SIRS
Sepsis	5	0
SIRS	2	2

[0649] MART. Multiple Additive Regression Trees (MART), also known as “gradient boosting machines,” was used to simultaneously assess the importance of biomarkers and classify the subject samples. Several fitting parameters are specified in this approach including (i) number of trees,

(ii) step size (commonly referred to as “shrinkage”), and (iii) degree of interaction (related to the number of splits for each tree). More information on MART is described in Section 5.5.4 above. The degree of interaction was set to 1 to enforce an additive model (e.g. each tree has one split and only uses one biomarker).

[0650] Estimating interactions may require more data to function well. The step size was set to 0.05 so that the model complexity was dictated by the number of trees. The optimal number of trees was estimated by leaving out a random subset of cases at each fitting iteration, then assessing quality of prediction on that subset. After fitting more trees than were warranted, the point at which prediction performance stopped improving was estimated as the optimal point.

[0651] The estimated model used 21 trees and 9 biomarkers across all trees. The MART algorithm also provides a calculation of biomarker importance (summing to 100%). Biomarkers ranked in decreasing order of importance to the model, with the most important biomarker first were: ARG2, GADD45B, OSM, LY96, INSL3, ANKRD22, MAP2K6, PSTPIP2, and TGFB1.

[0652] Cross-validation was carried out, with the optimal number of trees estimated independently in each of the 10 iterations. The confusion matrix for the training data where the predicted classifications were made from the cross-validated model is given in Table 78. From this confusion matrix, the overall accuracy was estimated to be 75% with a 95% confidence interval of 55.1 to 89.3%. The estimated sensitivity was 71.4% and the estimated specificity was 78.6%.

TABLE 78

Confusion matrix for the training samples using the cross-validated MART algorithm.		
Predicted	True Diagnosis	
	Sepsis	SIRS
Sepsis	10	3
SIRS	4	11

[0653] For the 9 validation samples held back from training, the overall accuracy was estimated to be 88.9% with a 95% confidence interval of 51.8% to 99.7%, sensitivity 100% and specificity 75%. Table 79 shows the confusion matrix for the validation samples.

TABLE 79

Confusion matrix for the validation samples using the MART algorithm.		
Predicted	True Diagnosis	
	Sepsis	SIRS
Sepsis	5	1
SIRS	0	3

[0654] PAM. Yet another decision rule developed using biomarkers of the present invention is predictive analysis of microarrays (PAM), which is described in Section 5.5.2, above. In this method, a shrinkage parameter that determines the number of biomarkers used to classify samples is specified. This parameter was chosen via cross-validation. There

were no biomarkers with missing values. Based on cross-validation, the optimal threshold value was 2.05, corresponding to 6 biomarkers.

[0655] Using the threshold of 2.05, the overall accuracy for the training samples was estimated to be 82.5% with a 95% confidence interval of 68.7% to 91%. The estimated sensitivity was 78.6% and the estimated specificity was 85.7%. Table 80 shows the confusion matrix for the training data where the predicted classifications were made from the cross-validated models.

TABLE 80

Confusion matrix for training samples using cross-validated PAM algorithm		
Predicted	True Diagnosis	
	Sepsis	SIRS
Sepsis	11	2
SIRS	3	12

[0656] For the 9 validation samples held back from training, the overall accuracy was estimated to be 77.8% with a 95% confidence interval of 40% to 97.2%, sensitivity 50% and specificity 100%. Table 81 shows the confusion matrix for the validation samples.

TABLE 81

Confusion matrix for validation samples using cross-validated PAM algorithm		
Predicted	True Diagnosis	
	Sepsis	SIRS
Sepsis	2	0
SIRS	2	5

[0657] The top six biomarkers identified by PAM, ranked from most important to least important were: GADD45B, TDRD9, MAP2K6, OSM, TNFSF10, and ANKRD22. FIG. 48 provides a summary of the CART, MART, PAM, and random forests (RF) classification algorithm (decision rule) performance and associated 95% confidence intervals using T_{-12} static data for the 44 biomarkers analyzed in this Section. Based on the results of the RT-PCR analysis summarized in FIG. 48 and at other time points, all forty-four biomarkers under study in this confirmation process were significant. Some of the biomarkers discriminated as early as T_{-60} .

6.13 Select Protein Biomarkers

[0658] In this example, experiments were performed in order to confirm which protein based biomarkers differentiate between patients who subsequently develop sepsis ("sepsis patients) and patients who do not ("SIRS patients). In the discovery process, samples were analyzed by a bead based protein immunoassay, as described in Section 6.13.1.

6.13.1 Discovery of Protein Biomarkers Using a Bead Based Protein Immunoassay

[0659] Multiplex Analysis. A set of biomarkers was analyzed simultaneously in real time, using a multiplex analysis method described in U.S. Pat. No. 5,981,180 ("the '180 patent"), herein incorporated by reference in its entirety, and

in particular for its teachings of the general methodology, bead technology, system hardware and antibody detection. For this analysis, a matrix of microparticles was synthesized, where the matrix consisted of different sets of microparticles. Each set of microparticles had thousands of molecules of a distinct antibody capture reagent immobilized on the micro particle surface and was color-coded by incorporation of varying amounts of two fluorescent dyes. The ratio of the two fluorescent dyes provided a distinct emission spectrum for each set of microparticles, allowing the identification of a microparticle within a set following the pooling of the various sets of microparticles. U.S. Pat. Nos. 6,268,222 and 6,599,331 also are incorporated herein by reference in their entirety, and in particular for their teachings of various methods of labeling microparticles for multiplex analysis.

[0660] The sets of labeled beads were pooled and combined with a plasma sample from individuals. The labeled beads were identified by passing them single file through a flow device that interrogated each microparticle with a laser beam that excited the fluorophore labels. An optical detector then measured the emission spectrum of each bead to classify the beads into the appropriate set. Because the identity of each antibody capture reagent was known for each set of microparticles, each antibody specificity was matched with an individual microparticle that passes through the flow device. U.S. Pat. No. 6,592,822 is also incorporated herein by reference in its entirety, and in particular for its teachings of multi-analyte diagnostic system that can be used in this type of multiplex analysis.

[0661] To determine the amount of analyte that bound a given set of microparticles, a reporter molecule was added such that it formed a complex with the antibodies bound to their respective analyte. In the present example, the reporter molecule was a fluorophore-labeled secondary antibody. The fluorophore on the reporter was excited by a second laser having a different excitation wavelength, allowing the fluorophore label on the secondary antibody to be distinguished from the fluorophores used to label the microparticles. A second optical detector measured the emission from the fluorophore label on the secondary antibody to determine the amount of secondary antibody complexed with the analyte bound by the capture antibody. In this manner, the amount of multiple analytes captured to beads could be measured in a single reaction.

[0662] Data Analysis and Results. For each sample, the concentrations of analytes that bound several different antibodies were measured. Each analyte is a biomarker, and the concentration of each analyte in the sample can be a feature of that biomarker. The biomarkers were analyzed with select antibody reagents listed in Table 14 of United States Patent Publication Number U.S. 2004/0096917 A1, which is hereby incorporated herein by reference in its entirety. These antibody reagents are commercially available from Rules Based Medicine (Austin, Tex.). The antibody reagents are categorized as specifically binding either (1) circulating protein biomarker components of blood, (2) circulating antibodies that normally bind molecules associated with various pathogens (identified by the pathogen that each biomarker is associated with, where indicated), or (3) autoantibody biomarkers that are associated with various disease states. Various approaches may be used to identify features that can inform a decision rule to classify individuals into the SIRS or sepsis groups. The methods chosen were CART, MART, PAM and random forests.

[0663] Biomarkers in multiple samples were measured using the above described assay at multiple time points and analyzed in several different ways: static time of entry, static T₋₆₀, static T₋₃₆, baseline T₋₆₀, baseline T₋₃₆, and baseline T₋₁₂ data points. Representative of these analyses is the static T₋₁₂ data analysis which is described in detail below. In the T₋₁₂ static analysis, biomarkers features were measured using a specific blood sample, designated the T₋₁₂ blood sample, as defined in Section 6.4, above.

[0664] For the T₋₁₂ static analysis, there were 60 biomarkers measured on 97 samples. Each sample was collected from a different member the population. Of these features, 53 were transformed by log transformations, 11 by square root transformations and the remaining 2 were not transformed.

[0665] The 97 member population was initially split into a training set (n=74) and a validation set (n=23). The training set was used to estimate the appropriate classification algorithm parameters while the trained algorithm was applied to the validation set to independently assess performance. Of the 74 training samples, 36 were labeled Sepsis, meaning that the subjects developed sepsis at some point during the observation time period, and 38 were labeled SIRS, meaning that they did not develop sepsis during the observation time period. Table 82 provides distributions of the race, gender and age for these samples.

TABLE 82

Distributions of the race, gender, and age for the training data				
Group	Gender	Black	Caucasian	Other
Sepsis	Male	10	14	1
	Female	0	10	1
SIRS	Male	5	24	0
	Female	0	9	0

Group	Minimum	Mean	Median	Maximum
Sepsis	18	43.2	40	80
SIRS	18	44.9	40	90

[0666] For the 23 validation samples, 12 were labeled Sepsis and 11 were labeled SIRS. Table 83 provides distributions of the race, gender and age for these samples.

TABLE 83

Distributions of the race, gender, and age for the validation data				
Group	Gender	Black	Caucasian	Other
Sepsis	Male	0	7	0
	Female	0	4	0
SIRS	Male	2	6	0
	Female	0	4	0

Group	Minimum	Mean	Median	Maximum
Sepsis	18	43.4	43	81
SIRS	19	51.9	51.5	85

[0667] Each sample in the training data was randomly assigned to one of ten groups used for cross-validation. The number of training samples in these groups ranged from 6 to 8. The samples were assigned in way that attempted to balance the number of sepsis and SIRS samples across folds. As described in more detail below, several different methods

were used to judge whether select biomarkers discriminate between the Sepsis and SIRS groups.

[0668] Wilcoxon and Q-value tests. The first method used to identify discriminating biomarkers was a Wilcoxon test (unadjusted). The abundance value for a given biomarker across the samples in the training data was subjected to the Wilcoxon test. The Wilcoxon test considers both group classification (sepsis versus SIRS) and abundance value in order to compute a p value for the given biomarker. The p value provides an indication of how well the abundance value for the given biomarker across the samples collected in the training set discriminates between the sepsis and SIRS state. The lower the p value, the better the discrimination. When the p value is less than a specific confidence level, such as 0.05, an inference is made that the biomarker discriminates between the sepsis and SIRS phenotype. There were 24 significant biomarkers using this method (see Table 84).

[0669] The second method used to identify discriminating biomarkers was the Wilcoxon Test (adjusted). Due to the large number of biomarkers, 60, in combination with the relatively small number of samples, 97, there was a high risk of finding falsely significant biomarkers. An adjusted p-value was used to counter this risk. In particular, the method of Benjamini and Hochberg, 1995, J.R. Statist. Soc. B 57, pp 289-300, which is hereby incorporated herein by reference in its entirety, was used to control the false discovery rate. Here, the false discovery rate is defined as the number of biomarkers truly significant divided by the number of biomarkers declared significant. For example, if the adjusted p-value is less than 0.05, there is a 5% chance that the biomarker is a false discovery. Results using this test are reported in Table 84. There were 16 significant biomarkers using this method (see Table 84). As used, herein, a biomarker is considered significant if it has a p-value of less than 0.05 as determined by the Wilcoxon test (adjusted).

[0670] The third method used to identify discriminating biomarkers was the use of Q values. In such an approach, the biomarkers are ordered by their q-values and if a respective biomarker has a q-value of X, then respective biomarker and all others more significant have a combined false discovery rate of X. However, the false discovery rate for any one biomarker may be much larger. There were 16 significant biomarkers using this method (see Table 84).

TABLE 84

Cumulative number of significant calls for the three methods. Note that all samples (training and validation) were used to compare Sepsis and SIRS groups. Missing biomarker feature values were not included in the analyses.							
	≤1e-04	≤0.001	≤0.01	≤0.025	≤0.05	≤0.1	≤1
p-value (unadjusted)	0	6	14	20	24	25	60
p-value (adjusted)	0	0	6	13	16	24	60
q-value	0	0	13	20	25	31	60

[0671] CART. In addition to analyzing the microarray data using Wilcoxon and Q-value tests in order to identify biomarkers that discriminate between the sepsis and SIRS subpopulations in the training set, classification and regression tree (CART) analysis was used. CART is described in Section 5.5.1, above. Specifically, the data summarized above was used to predict the disease state by iteratively partitioning the

data based on the best single-variable split of the data. In other words, at each stage of the tree building process, the biomarker whose expression values across the training population best discriminate between the sepsis and SIRS population was invoked as a decision branch. Cross-validation was carried out, with the optimal number of splits estimated independently in each of the 10 iterations. The final tree is depicted in FIG. 49, and uses ten biomarkers: MIP1 beta, thrombopoietin, C reactive protein, IL-10, IL-16, beta-2 microglobulin, alpha fetoprotein, IL-6, adiponectin, and ICAM1.

[0672] FIG. 50 shows the distribution of the ten biomarkers used in the decision tree between the sepsis and SIRS groups in the training data set. In FIG. 50, the top of each box denotes the 75th percentile of the data across the training set and the bottom of each box denotes the 25th percentile, and the median value for each biomarker across the training set is drawn as a line within each box. The confusion matrix for the training data where the predicted classifications were made from the cross-validated model is given in Table 85. From this confusion matrix, the overall accuracy was estimated to be 63.5% with a 95% confidence interval of 51.5% to 74.4%. The estimated sensitivity was 66.7% and the estimated specificity was 60.5%.

TABLE 85

Confusion matrix for training samples using cross-validated CART		
Predicted	True Diagnosis	
	Sepsis	SIRS
Sepsis	24	15
SIRS	12	23

[0673] For the 23 validation samples held back from training data set, the overall accuracy was estimated to be 65.2% with a 95% confidence interval of 42.7% to 83.6%, sensitivity 66.7% and specificity 63.6%. Table 86 shows the confusion matrix for the validation samples.

TABLE 86

Confusion matrix for validation samples using cross-validated CART		
Predicted	True Diagnosis	
	Sepsis	SIRS
Sepsis	8	1
SIRS	4	10

[0674] Random Forests. Another decision rule that can be developed using biomarkers of the present invention is a Random Forests decision tree. Random Forests is a tree based method that uses bootstrapping instead of cross-validation. For each iteration, a random sample (with replacement) is drawn and the largest tree possible is grown. Each tree receives a vote in the final class prediction. To fit a random forest, the number of trees (e.g. bootstrap iterations) is specified. No more than 500 were used in this example, but at least 50 are needed for a burn-in period. The number of trees was chosen based on the accuracy of the training data. For this data, 64 trees were used to train the algorithm (see FIG. 51). In FIG. 51, curve 4802 is a smoothed estimate of overall accuracy as a function of tree number. Curve 4804 is a

smoothed curve of tree sensitivity as a function of tree number. Curve 4806 is a smoothed curve of tree specificity as a function of tree number. Using this algorithm, 34 biomarkers had non-zero importance and were used in the model. The random forest algorithm gauges biomarker importance by the average reduction in the training accuracy. The biomarkers were ranked by this method and are shown in FIG. 52. The random forest method uses a number of different decision trees. A biomarker is considered to have discriminating significance if it served as a decision branch of a decision tree from a significant random forest analysis. As used herein, a significant random forest analysis is one where the lower 95% confidence interval on accuracy by cross validation on a training data set is greater than 50% and the point estimate for accuracy on a validation set is greater than 65%.

[0675] The predicted confusion matrix for the training dataset using the decision tree developed using the Random Forest method is given in Table 87. From this confusion matrix, the overall accuracy was estimated to be 70.3% (confidence intervals cannot be computed when using the bootstrap accuracy estimate). The estimated sensitivity was 69.4% and the estimated specificity was 71.1%.

TABLE 87

Confusion matrix for training samples against the decision tree developed using the Random Forest method.		
Predicted	True Diagnosis	
	Sepsis	SIRS
Sepsis	27	11
SIRS	11	25

[0676] For the 23 validation samples held back from training, the overall accuracy was estimated to be 60.9% with a 95% confidence interval of 38.5% to 80.3%, sensitivity 83.3% and specificity 36.4%. Table 88 shows the confusion matrix for the validation samples.

TABLE 88

Confusion matrix for the 23 validation samples against the decision tree developed using the Random Forest method.		
Predicted	True Diagnosis	
	Sepsis	SIRS
Sepsis	10	7
SIRS	2	4

[0677] MART. MART was used to simultaneously assess the importance of biomarkers and classify the subject samples. Several fitting parameters are specified in this approach including (i) number of trees, (ii) step size (commonly referred to as “shrinkage”), and (iii) degree of interaction (related to the number of splits for each tree). More information on MART is described in Section 5.5.4 above. The degree of interaction was set to 1 to enforce an additive model (e.g. each tree has one split and only uses one biomarker).

[0678] The degree of interaction was set to 1 to enforce an additive model (e.g. each tree has one split and only uses one feature), because this often works well even when a weak interaction is present. Moreover, estimating interactions may

require more data to function well. The step size was set to 0.05 so that the model complexity was dictated by the number of trees. The optimal number of trees was estimated by leaving out a random subset of cases at each fitting iteration, then assessing quality of prediction on that subset. After fitting more trees than were warranted, the point at which prediction performance stopped improving was estimated as the optimal point.

[0679] The estimated model used 11 trees and 4 biomarkers across all trees. The MART algorithm also provides a calculation of biomarker importance (summing to 100%), which are given in FIG. 53. Biomarkers with zero importance were excluded. FIG. 54 shows the distribution of the selected biomarkers between the Sepsis and SIRS groups.

[0680] Cross-validation was carried out, with the optimal number of trees estimated independently in each of the 10 iterations. The confusion matrix for the training data where the predicted classifications were made from the cross-validated model is given in Table 89. From this confusion matrix, the overall accuracy was estimated to be 70.3% with a 95% confidence interval of 58.5% to 80.3%. The estimated sensitivity was 63.9% and the estimated specificity was 76.3%.

TABLE 89

Confusion matrix for the training samples using the cross-validated MART algorithm.		
Predicted	True Diagnosis	
	Sepsis	SIRS
Sepsis	23	9
SIRS	13	29

[0681] For the 23 validation samples held back from training, the overall accuracy was estimated to be 73.9% with a 95% confidence interval of 51.6% to 89.8%, sensitivity 63.6% and specificity 83.3%. Table 90 shows the confusion matrix for the validation samples.

TABLE 90

Confusion matrix for the validation samples using the MART algorithm.		
Predicted	True Diagnosis	
	Sepsis	SIRS
Sepsis	7	2
SIRS	4	10

[0682] PAM. Yet another decision rule developed using biomarkers of the present invention is predictive analysis of microarrays (PAM), which is described in Section 5.5.2, above. In this method, a shrinkage parameter that determines the number of biomarkers used to classify samples is specified. This parameter was chosen via cross-validation. There were no biomarkers with missing values. Based on cross-validation, the optimal threshold value was 0.08, corresponding to 59 biomarkers. FIG. 55 shows the accuracy across different thresholds. In FIG. 55, curve 5202 is the overall accuracy (with 95% confidence interval bars). Curve 5204 shows decision rule sensitivity as a function of threshold value. Curve 5206 shows decision rule specificity as a function of threshold value. Using the threshold of 0.08, the over-

all accuracy for the training samples was estimated to be 74.9 with a 95% confidence interval of 65.3% to 82.5%. The estimated sensitivity was 78.9% and the estimated specificity was 69.4%. Table 91 shows the confusion matrix for the training data where the predicted classifications were made from the cross-validated models.

TABLE 91

Confusion matrix for training samples using cross-validated PAM algorithm		
Predicted	True Diagnosis	
	Sepsis	SIRS
Sepsis	30	11
SIRS	8	25

[0683] For the 23 validation samples held back from training, the overall accuracy was estimated to be 65.2% with a 95% confidence interval of 42.7% to 83.6%, sensitivity 91.7% and specificity 36.4%. Table 92 shows the confusion matrix for the validation samples.

TABLE 92

Confusion matrix for validation samples using cross-validated PAM algorithm		
Predicted	True Diagnosis	
	Sepsis	SIRS
Sepsis	11	7
SIRS	1	4

[0684] FIG. 56 shows the selected biomarkers, ranked by their relative discriminatory power, and their relative importance in the model.

[0685] FIG. 57 provides a summary of the CART, MART, PAM, and random forests (RF) classification algorithm (decision rule) performance and associated 95% confidence intervals. Fifty distinct biomarkers were selected from across all the algorithms illustrated in FIG. 58. The identity of these fifty selected features is found in FIG. 58.

[0686] FIG. 58 illustrates an overall ranking of biomarkers for the T₋₁₂ data set. For the selected biomarkers, the x-axis depicts the percentage of times that it was selected. Within the percentage of times that biomarkers were selected, the biomarkers are ranked.

[0687] From the analysis of the T₋₁₂ data set and the other data sets, ten protein based biomarkers were selected for confirmation using the methodology described in Section 16.3.2. These biomarkers are listed in Table 93, below.

TABLE 93

Protein based biomarkers selected for confirmation from immunoassay			
Gene Symbol	Gene Name	Gene Accession Number	Protein Accession Number
IL-6	INTERLEUKIN 6	NM_000600	NP_000591
IL-8	INTERLEUKIN 8	M28130	AAA59158
CRP	C Reactive protein	CAA39671	NM_000567
IL-10	INTERLEUKIN 10	NM_000572	CAH73907

TABLE 93-continued

Protein based biomarkers selected for confirmation from immunoassay			
Gene Symbol	Gene Name	Gene Accession Number	Protein Accession Number
APOC3	APOLIPOPROTEIN CIII	NM_000040	CAA25648
MMP9	MATRIX METALLOPROTEINASE 9 (GELATINASE B, 92 KDA GELATINASE, 92 KDA TYPE IV COLLAGENASE)	NM_004994	NP_004985
TIMP1	TISSUE INHIBITOR OF METALLOPROTEINASE 1	NM_003254	AAA75558
MCP1	MONOCYTE CHEMOATTRACTANT PROTEIN 1	AF493698, AF493697	AAQ75526
AFP	ALPHA-FETOPROTEIN	NM_001134	CAA79592
B2M	BETA-2 MICROGLOBULIN	NM_004048	AAA51811

[0688] Each of the sequences, genes, proteins, and probesets identified in Table 93 is hereby incorporated by reference.

6.13.2 Confirmation of Protein Biomarkers Using a Bead Based Protein Immunoassay

[0689] Confirmation of the biomarkers identified in Table 93 was performed using the same assay described in Section 6.13.1 at multiple time points and analyzed in several different ways: static time of entry, static T_{-60} , static T_{-36} , baseline T_{-60} , baseline T_{-36} , and baseline T_{-12} data points. Representative of these analyses is the static T_{-12} data analysis which is described in detail below. In the T_{-12} static analysis, biomarkers features were measured using a specific blood sample, designated the T_{-12} blood sample, as defined in Section 6.4, above. FIG. 59 illustrates the results of the analysis of static T_{-12} bead based protein assay, using CART, MART, PAM and random forests, where the static T_{-12} time point is as described in Section 6.4. The best decision tree in both the training and validation datasets for CART used six biomarkers. For both the training data and the validation data, the estimated model for MART used 4 biomarkers across all trees. A total of 7 biomarkers were of significance in both the training and the validation sets using PAM. Using random forest, 4 biomarkers under study were actually found to have discriminating significance in both the training and validation data sets. Based on the results of the analysis of the bead based protein immunoassay summarized in FIG. 59, each of the ten protein based biomarkers identified in Section 6.13.1 were confirmed by this experiment.

6.13.3 Confirmation of Protein Biomarkers Using BD Cytometric Bead Array Assay

[0690] IL-6, IL-8, and IL-10 proteins were confirmed using the BD™ Cytometric Bead Array (CBA) assay as embodied in the BD™ CBA Human Inflammation Kit. Flow cytometry is an analysis tool that allows for the discrimination of different particles on the basis of size and color. Multiplexing is the simultaneous assay of many analytes in a single sample. CBA employs a series of particles with discrete fluorescence intensities to simultaneously detect multiple soluble analytes. CBA is combined with flow cytometry to create a multiplexed assay. The BD CBA system uses the sensitivity of amplified

fluorescence detection by flow cytometry to measure soluble analytes in a particle-based immunoassay. Each bead in a CBA provides a capture surface for a specific protein and is analogous to an individually coated well in an ELISA plate. The BD CBA capture bead mixture is in suspension to allow for the detection of multiple analytes in a small volume sample.

[0691] The combined advantages of the broad dynamic range of fluorescent detection via flow cytometry and the efficient capturing of analytes via suspended particles enable CBA to use fewer sample dilutions and to obtain the value of an unknown in substantially less time (compared to conventional ELISA). The BD™ CBA Human Inflammation Kit can be used to quantitatively measure Interleukin-8 (IL-8), Interleukin-1P (IL-1 Interleukin-6 (IL-6), Interleukin-10 (IL-10), Tumor Necrosis Factor (TNF), and Interleukin-12p70 (IL-12p70) protein levels in a single sample. The kit performance has been optimized for analysis of specific proteins in tissue culture supernatants, EDTA plasma, and serum samples.

[0692] Six bead populations with distinct fluorescence intensities have been coated with capture antibodies specific for IL-8, IL-1 β , IL-6, IL-10, TNF, and IL-12p70 proteins. The six bead populations are mixed together to form the BD™ CBA which is resolved in the FL3 channel of a flow cytometer such as the BD FACScan™ or BD FACSCalibur™ flow cytometer. The capture beads, PE-conjugated detection antibodies, and recombinant standards or test samples are incubated together to form sandwich complexes. Following acquisition of sample data using the flow cytometer, the sample results are generated in graphical and tabular format using the BD™ CBA Analysis Software. More details about the BD™ CBA Human Inflammation Kit are described in the BD™ CBA Human Inflammation Kit Instruction Manual, catalog number 551811, available from BD biosciences, which is hereby incorporated by reference herein in its entirety. Using the BD™ CBA Human Inflammation Kit, the biomarkers IL-6, IL-8, and IL-10 were confirmed as discriminating between sepsis and SIRS.

6.14 Assessing Subcombinations of the Biomarkers Identified in Table I

[0693] One embodiment of the present invention encompasses any 2 or more of the 53 biomarkers listed in Table I as predictors for classifying a subject as sepsis or SIRS. One embodiment of the present invention encompasses any 3 or more of the 53 biomarkers listed in Table I as predictors for classifying a subject as sepsis or SIRS. As such, the present invention further encompasses any subcombination of the 53 biomarkers listed in Table I as predictors for classifying a subject as sepsis or SIRS provided that there are at least 2 or 3 biomarkers in the subcombination. This section discloses experiments that demonstrate the predictive power of exemplary subcombinations of the 53 biomarkers listed in Table I. Several thousand subcombinations were tested and the vast majority of those subcombinations had an accuracy of at least seventy percent. This indicates that the vast majority of the possible subcombinations of the 53 biomarkers listed in Table I will discriminate between sepsis and SIRS subjects.

6.14.1 Subcombinations of Nucleic Acid Biomarkers at T_{-12}

[0694] There are a total of 44 biomarkers for which RT-PCR nucleic acid data is available as reported in Table J. A

total of 4800 different subcombinations of this set of biomarkers were constructed using the T_{-12} time point data described in Section 6.12. Each different subcombination was then tested for its ability to discriminate between sepsis subjects and SIRS subjects. The 4800 subcombinations represent a random sampling of the total number of possible subcombinations possible for the 44 biomarkers of the present invention reported in Table J. Randomness of the 4800 subcombinations was ensured using the following algorithm:

```

CONSIDER 2 to 25 biomarkers from Table J
{
  LET the current number be k;
  DO the following 200 times
  {
    SELECT k biomarkers at random from Table J;
    LET the current set of biomarkers be S;
  }
  DO the following 10 times
  {
    FOR biomarker set S, randomly set aside 10% of patients as a
    validation population and 90% as a training population;
    FIT a model to the training population using Random Forest
    with  $T_{-12}$ 
    time point data;
    PREDICT results for the validation population;
    CALCULATE agreement with the known status of the validation
    population;
  }
  AVERAGE the ten agreement rates and report;
  SET k = k+1;
  IF k > 10 then END; ELSE return to top;
}
END

```

[0695] There were a total of 152 patients for which T_{-12} data was available from a combination of discovery and confirmatory data described above. Of these 152 patients, 80 were sepsis and 72 were SIRs. The calculations described above test 200 subcombinations at each interval 2 through 25. In other words, 200 subcombinations each consisting of two biomarkers randomly selected from Table J were tested, 200 subcombinations each consisting of three biomarkers randomly selected from Table J were tested, and so forth, through 200 subcombinations each consisting of twenty-five biomarkers randomly selected from Table J for a total of 24 families of subcombinations, where each family of subcombinations consists of 200 subcombinations of biomarkers each having k biomarkers, where k is a number in the set 2 through 25.

[0696] The data set with assay results for all biomarkers under consideration was maintained in memory, as were a list of unique biomarker names. To evaluate subsets of a specific size (say, $k=three$), then that many (three) biomarker names were selected randomly from the set of unique biomarker names, using a pseudorandom number generators provided in the R software package. See Venables and Smith, *An Introduction to R*, ISBN 0-9541617-4-2, which is hereby incorporated by reference in its entirety. A matrix of assay results for the selected biomarker names was constructed. This matrix could have more columns than the number of selected biomarker names, since some biomarkers have more than one assay result. An estimate of true predictive accuracy, when using the modeling technique "Random Forest," was then constructed for this matrix. The Random Forest algorithm was implemented as described in Breiman, 2001, "Random

Forests," *Machine Learning* 45(1), pp. 5-32, which is hereby incorporated by reference in its entirety.

[0697] For a given data matrix, the prediction of true predictive accuracy was calculated as follows: 10% of patients were randomly selected in a balanced manner, i.e., 10% of septic patients and 10% of SIRS patients were selected. Selected patients were set aside for the validation population, and a random forest model was fitted to the remaining data (the training population). If there were any missing values in the training data or the set-aside data, a recursive partitioning model was fitted to other assay results as well as the Sepsis/SIRS information in order to predict assay values. The recursive partitioning model is described in Breiman et al., 1984, *Classification and Regression Trees*, Wadsworth, which is hereby incorporated by reference in its entirety. Missing values were then replaced with their predicted values. Missing values in the set-aside data were replaced with predictions from the recursive-partition model fitted to the training data, so that knowledge of the SIRS/Sepsis status for the validation population was not used in any way to classify validation patients.

[0698] By comparing the true status of the 10% set aside (the validation population) with the predicted status according to the random forest model fitted to the other 90% (the training population), sensitivity, specificity, and agreement were calculated. This process was repeated 10 times, and the final sensitivity, specificity, and agreement estimates (also termed accuracy, also termed performance) for the given marker subset were those values averaged across the 10 iterations. This process was applied to every subset. For each size considered (k value, i.e., number of biomarkers), 200 random subsets were selected and evaluated. These 200 performance (accuracy) estimates form an estimate of the distribution of performances of all subsets of biomarkers of a given size (k value).

[0699] FIG. 60 plots the accuracy of each of these 24 families of subcombinations as bar graphs. FIG. 61 plots the accuracy (performance) of each individual subcombination in each of the 24 families of subcombinations. Thus, FIG. 61 plots the accuracy (performance) of a total of 4800 subcombinations of the set of biomarkers listed in Table J.

[0700] FIGS. 60 and 61 indicate that for $k>5$, the distributions are Gaussian, (bell-shaped), indicating that each respective family ($k=5, \dots, 24$) is an accurate depiction of the subcombination space represented by the family. For $k\leq 5$, a handful of subsets give lower accuracy (performance) estimates. However, the results available for $k\leq 5$ indicate that this class of biomarker subcombinations discriminate between sepsis and SIRS as well. The results reported in FIGS. 60 and 61 show that, with as few as two biomarkers randomly selected from Table J, an accuracy (performance) estimate above 50% was virtually always obtained. Table 94 contains the number of subcombinations in each family ($k=2, 4, \dots, 25$) that performed with a threshold accuracy of greater than 60% (column 2), greater than 70% (column 3), greater than 80% (column 4), greater than 90% (column 5), or an accuracy of less than 60% (column 6). The data summarized in FIGS. 60 and 61, as well as Table 94, demonstrates that, for time T_{-12} data, almost all subcombinations of biomarkers comprising between 2 and 25 biomarkers from Table J will discriminate between sepsis and SIRs subjects.

TABLE 94

Number of subcombinations from Table J that performed with a given threshold accuracy using T ₋₁₂ nucleic acid data					
Column 1 Number of Biomarkers	Column 2 Greater than 60%	Column 3 Greater than 70%	Column 4 Greater than 80%	Column 5 Greater than 90%	Column 6 Less than 60%
2	197	145	17	0	3
3	199	160	25	0	1
4	199	174	38	0	1
5	200	186	51	0	0
6	200	194	50	0	0
7	200	195	48	0	0
8	200	194	64	0	0
9	200	200	61	1	0
10	200	196	64	0	0
11	200	196	70	0	0
12	200	199	70	0	0
13	200	199	73	0	0
14	200	198	67	0	0
15	200	198	79	0	0
16	200	198	70	0	0
17	200	198	64	0	0
18	200	199	84	0	0
19	200	197	83	0	0
20	200	199	82	0	0
21	200	199	85	0	0
22	200	198	80	0	0
23	200	200	83	0	0
24	200	198	83	0	0
25	200	198	81	0	0

6.14.2 Subcombinations of Protein Biomarkers at T₋₁₂

[0701] There are a total of 10 biomarkers for which protein abundance data is available as reported in Table K. A total of 1600 different subcombinations of this set of biomarkers were constructed using the T₋₁₂ time point data described in Section 6.13. Each different subcombination was then tested for its ability to discriminate between sepsis and SIRS subjects. The 1600 subcombinations represent a random sampling of the total number of possible subcombinations possible for the 10 biomarkers of the present invention reported in Table K. Randomness of the 1600 subcombinations was ensured using the following algorithm:

```

CONSIDER 3 to 10 biomarkers from Table K
{
  LET the current number be k;
  DO the following 200 times
  {
    SELECT k biomarkers at random from Table K;
    LET the current set of biomarkers be S;
  }
  DO the following 10 times
  {
    FOR biomarker set S, randomly set aside 10% of patients as a validation population and 90% as a training population;
    FIT a model to the training population using Random Forest with T-12 time point data;
    PREDICT results for the validation population;
    CALCULATE agreement with the known status of the validation population;
  }
}

```

-continued

```

}
AVERAGE the ten agreement rates and report;
SET k = k+1;
IF k > 10 then END; ELSE return to top;
}
END

```

[0702] Computations were performed as described in further detail in Section 6.14.1. There were a total of 152 patients for which T₋₁₂ data was available from a combination of discovery and confirmatory data described above. Of these 152 patients, 80 were sepsis and 72 were SIRS. For some biomarkers in Table K, there were multiple data sources. For instance, there is IL-6, IL-8, and IL-10 protein data from three different labs. Thus, there is a complex pattern of incidence among patients. Some patients may be tested by one lab, others by two, etc. This was determined by how the project evolved and what samples were available (some patient samples were exhausted before they could be tested with assays developed later). To handle this complex incidence, the following strategy was used. In any given iteration, if a protein that was tested in multiple labs was selected, all assay results for the protein were selected. A missing-value imputation scheme was then used to fill out missing values, making it look like all patients were tested with all assays. This data was then fed into the Random Forest model as correlated inputs that measure the same underlying compound. Thus, consider the case where k is equal to 3 and one of the randomly chosen proteins from Table K is IL-8, from 3 different laboratories, and the other 2 proteins are unique meaning that they are each from only one laboratory. The data from all three IL-8 sources are selected, plus the other two unique assays for the other two proteins, for a total of five assays. The missing-value imputation scheme is then used to fill out missing values, making it look like all patients had results from three different sources for a total of nine assays.

[0703] The calculations described above test 200 subcombinations at each interval 3 through 10. In other words, 200 subcombinations each consisting of three randomly selected biomarkers from Table K were tested, 200 subcombinations each consisting of four biomarkers randomly selected from Table K were tested, and so forth, through 200 subcombinations each consisting of ten biomarkers randomly selected from Table K for a total of 8 families of subcombinations, where each family of subcombinations consists of 200 subcombinations of biomarkers all having k biomarkers, where k is a number in the set 3 through 10. FIG. 62 plots the accuracy of each of these eight families of subcombinations as bar graphs. FIG. 63 plots the accuracy (performance) of each individual subcombination in each of the eight families of subcombinations. Thus, FIG. 63 plots the accuracy (performance) of a total of 1600 subcombinations of the set of biomarkers listed in Table K.

[0704] FIGS. 62 and 63 show that the distribution for each family of subcombinations is Gaussian (bell-shaped), indicating that each respective family (k=3, 4, . . . , 10) is an accurate depiction of the subcombination space represented by the family. The results reported in FIGS. 62 and 63 show that, with as few as three biomarkers randomly selected from Table K, an accuracy (performance) estimate above 50% was virtually always obtained. Table 95 contains the number of subcombinations in each family (k=3, 4, . . . , 10) that per-

formed with a threshold accuracy of greater than 60% (column 2), greater than 70% (column 3), greater than 80% (column 4), greater than 90% (column 5), or an accuracy of less than 60% (column 6). The data summarized in FIGS. 62 and 63, as well as Table 95, demonstrates that, for time T_{-12} data, almost all subcombinations of biomarkers comprising between 3 and 10 biomarkers from Table K will discriminate between sepsis and SIRS subjects.

TABLE 95

Number of subcombinations from Table K that performed with a given threshold accuracy using T_{-12} protein data					
Column 1 Number of Biomarkers	Column 2 Greater than 60%	Column 3 Greater than 70%	Column 4 Greater than 80%	Column 5 Greater than 90%	Column 6 Less than 60%
3	192	58	0	0	8
4	196	106	1	0	4
5	200	117	1	0	0
6	200	136	0	0	0
7	200	151	1	0	0
8	200	172	1	0	0
9	200	188	1	0	0
10	200	187	0	0	0

6.14.3 Subcombinations of Protein Biomarkers at T_{-36}

[0705] A total of 1600 different subcombinations of the set of biomarkers of Table K were constructed for the T_{-36} time point using the protein based data described in Section 6.13. Each different subcombination was then tested for its ability to discriminate between sepsis and SIRS subjects. There were a total of 142 patients for which T_{-36} data was available from a combination of discovery and confirmatory data described above. Of these 142 patients, 79 were sepsis and 63 were SIRS. The 1600 subcombinations represent a random sampling of the total number of possible subcombinations possible for the 10 biomarkers of the present invention reported in Table K. Randomness of the 1600 subcombinations was ensured using the algorithm identified in Section 6.14.2, the only difference being that T_{-36} data rather than T_{-12} data was used. Computations were performed as described in further detail in Section 6.14.1. FIG. 64 plots the accuracy of each of these eight families of subcombinations as bar graphs. FIG. 65 plots the accuracy (performance) of each individual subcombination in each of the eight families of subcombinations. Thus, FIG. 65 plots the accuracy (performance) of a total of 1600 subcombinations of the set of biomarkers listed in Table K.

[0706] The results reported in FIGS. 64 and 65 show that, with as few as three biomarkers randomly selected from Table K, an accuracy (performance) estimate above 60% was typically obtained. Table 95 contains the number of subcombinations in each family ($k=3, 4, \dots, 10$) that performed with a threshold accuracy of greater than 60% (column 2), greater than 70% (column 3), greater than 80% (column 4), greater than 90% (column 5), or an accuracy of less than 60% (column 6). The data summarized in FIGS. 64 and 65, as well as Table 95, demonstrates that, for time T_{-36} data, most subcombinations of biomarkers comprising between 3 and 10 biomarkers from Table K will discriminate between sepsis and SIRS subjects.

TABLE 96

Number of subcombinations from Table K that performed with a given threshold accuracy using T_{-36} protein data					
Column 1 Number of Biomarkers	Column 2 Greater than 60%	Column 3 Greater than 70%	Column 4 Greater than 80%	Column 5 Greater than 90%	Column 6 Less than 60%
3	138	23	0	0	62
4	152	25	0	0	48
5	171	32	0	0	29
6	180	30	0	0	20
7	188	37	0	0	12
8	194	40	0	0	6
9	194	27	0	0	6
10	199	20	0	0	1

6.14.4 Subcombinations of Nucleic Acid Biomarkers at T_{-36}

[0707] A total of 4600 different subcombinations of the set of biomarkers of Table J were constructed for the T_{-36} time point using the nucleic acid based data described in Section 6.13. Each different subcombination was then tested for its ability to discriminate between sepsis and SIRS subjects. There were a total of 142 patients for which T_{-36} data was available from a combination of discovery and confirmatory data described above. Of these 142 patients, 79 were sepsis and 63 were SIRS. The 4600 subcombinations represent a random sampling of the total number of possible subcombinations possible for the 44 biomarkers of the present invention reported in Table J at the T_{-36} time point. Randomness of the 4600 subcombinations was ensured using the algorithm identified in Section 6.14.1, the only difference being that T_{-36} data rather than T_{-12} data was used and that the minimum k value was 3. Computations were performed as described in further detail in Section 6.14.1. FIG. 66 plots the accuracy of each of these 23 families of subcombinations as bar graphs. FIG. 67 plots the accuracy (performance) of each individual subcombination in each of the 23 families of subcombinations. Thus, FIG. 67 plots the accuracy (performance) of a total of 4600 subcombinations of the set of biomarkers listed in Table J.

[0708] The results reported in FIGS. 66 and 67 show that, with as few as three biomarkers randomly selected from Table J, an accuracy (performance) estimate above 60% was typically obtained. Table 97 contains the number of subcombinations in each family ($k=3, 4, \dots, 25$) that performed with a threshold accuracy of greater than 60% (column 2), greater than 70% (column 3), greater than 80% (column 4), greater than 90% (column 5), or an accuracy of less than 60% (column 6). The data summarized in FIGS. 66 and 67, as well as Table 97, demonstrate that, for time T_{-36} data, most subcombinations of biomarkers comprising between 3 and 25 biomarkers from Table J will discriminate between sepsis and SIRS subjects.

TABLE 97

Number of subcombinations from Table J that performed with a given threshold accuracy using $T_{3,6}$ nucleic acid data					
Column 1 Number of Biomarkers	Column 2 Greater than 60%	Column 3 Greater than 70%	Column 4 Greater than 80%	Column 5 Greater than 90%	Column 6 Less than 60%
3	194	115	4	0	6
4	196	128	8	0	4
5	200	159	6	0	0
6	200	161	6	0	0
7	200	173	10	0	0
8	200	182	10	0	0
9	200	189	8	0	0
10	200	188	10	0	0
11	200	194	10	0	0
12	200	193	13	0	0
13	200	190	19	0	0
14	200	192	24	0	0
15	200	196	20	0	0
16	200	195	16	0	0
17	200	196	22	0	0
18	200	195	18	0	0
19	200	196	14	0	0
20	200	194	14	0	0
21	200	197	14	0	0
22	200	197	11	0	0
23	200	200	15	0	0
24	200	199	20	0	0
25	200	199	19	0	0

6.14.5 Subcombinations of Combined Nucleic Acid and Protein Biomarker Data at T_{-12}

[0709] There are a total of 53 biomarkers listed Table I. A total of 4600 different subcombinations of this set of biomarkers were constructed using all available T_{-12} time point data. For the subset of biomarkers in Table I that are listed in Table J, the T_{-12} time point data consisted of RT-PCR data described above. For the subset of biomarkers that are listed in Table K, the T_{-12} time point data consisted of bead based data described above. The one exception to this was “MMP9” for which both protein and gene-expression data was available. Therefore, MMP9 gene and protein abundance data was treated as separate biomarkers. To accomplish this, MMP9 nucleic data was termed “MMP9.GE” and MMP9 protein abundance data from the bead based assays was termed MMP9.Protein.

[0710] Each different subcombination was tested for its ability to discriminate between sepsis subjects and SIRS subjects. The 4600 subcombinations represent a random sampling of the total number of possible subcombinations possible for the 53 biomarkers of the present invention reported in Table I. Randomness of the 4600 subcombinations was ensured using the following algorithm:

```

CONSIDER 3 to 25 biomarkers from Table I
{
  LET the current number be k;
  DO the following 200 times
  {
    SELECT k biomarkers at random from Table I;
    LET the current set of biomarkers be S;
  }
  DO the following 10 times
  {

```

-continued

```

FOR biomarker set S, randomly set aside 10% of patients as a
validation population and 90% as a training population;
FIT a model to the training population using Random Forest
with  $T_{-12}$  time point data;
PREDICT results for the validation population;
CALCULATE agreement with the known status of the validation
population;
}
AVERAGE the ten agreement rates and report;
SET k = k+1;
IF k > 10 then END; ELSE return to top;
}
END

```

[0711] There were a total of 152 patients for which T_{-12} data was available from a combination of discovery and confirmatory data described above. Of these 152 patients, 80 were sepsis and 72 were SIRs. Computations were performed as described in further detail in Section 6.14.1. The calculations described above test 200 subcombinations at each interval 2 through 25. In other words, 200 subcombinations each consisting of three biomarkers randomly selected from Table I were tested, 200 subcombinations each consisting of four biomarkers randomly selected from Table I were tested, and so forth, through 200 subcombinations each consisting of twenty-five biomarkers randomly selected from Table I for a total of 23 families of subcombinations, where each family of subcombinations consists of 200 subcombinations of biomarkers each having k biomarkers, where k is a number in the set 3 through 25. FIG. 68 plots the accuracy of each of these 23 families of subcombinations as bar graphs. FIG. 69 plots the accuracy (performance) of each individual subcombination in each of the 23 families of subcombinations. Thus, FIG. 69 plots the accuracy (performance) of a total of 4600 subcombinations of the set of biomarkers listed in Table I.

[0712] FIGS. 68 and 69 indicate that for $k > 5$, the distributions are Gaussian, (bell-shaped), indicating that each respective family ($k=5, \dots, 25$) is an accurate depiction of the subcombination space represented by the family. For $k \leq 5$, a handful of subsets give lower accuracy (performance) estimates. The results reported in FIGS. 68 and 69 show that, with as few as three biomarkers randomly selected from Table I, an accuracy (performance) estimate above 50% was virtually always obtained. Table 98 contains the number of subcombinations in each family ($k=3, 4, \dots, 25$) that performed with a threshold accuracy of greater than 60% (column 2), greater than 70% (column 3), greater than 80% (column 4), greater than 90% (column 5), or an accuracy of less than 60% (column 6). The data summarized in FIGS. 68 and 69, as well as Table 98, demonstrate that, for time T_{-12} data, almost all subcombinations of biomarkers comprising between 3 and 25 biomarkers from Table I will discriminate between sepsis and SIRs subjects.

TABLE 98

Number of subcombinations from Table I that performed with a given threshold accuracy using T_{-12} combined nucleic acid and protein data					
Column 1 Number of Biomarkers	Column 2 Greater than 60%	Column 3 Greater than 70%	Column 4 Greater than 80%	Column 5 Greater than 90%	Column 6 Less than 60%
3	200	157	11	0	0
4	200	166	12	0	0

TABLE 98-continued

Number of subcombinations from Table I that performed with a given threshold accuracy using T ₋₁₂ combined nucleic acid and protein data					
Column 1 Number of Biomarkers	Column 2 Greater than 60%	Column 3 Greater than 70%	Column 4 Greater than 80%	Column 5 Greater than 90%	Column 6 Less than 60%
5	200	191	25	0	0
6	200	191	30	0	0
7	200	195	33	0	0
8	200	198	44	0	0
9	200	200	49	0	0
10	200	198	63	0	0
11	200	199	65	0	0
12	200	200	71	0	0
13	200	200	64	0	0
14	200	200	66	0	0
15	200	200	74	0	0
16	200	199	74	0	0
17	200	200	73	0	0
18	200	200	76	0	0
19	200	200	87	0	0
20	200	199	94	0	0
21	200	200	77	0	0
22	200	200	84	0	0
23	200	200	81	0	0
24	200	200	93	0	0
25	200	200	85	0	0

6.14.6 Subcombinations of Combined Nucleic Acid and Protein Biomarker Data at T₋₃₆

[0713] Subcombinations of biomarkers were selected as described in Section 6.14.5, the only difference being that T₋₃₆ data rather than T₋₁₂ data was used. A total of 4600 different subcombinations of Table I were constructed using all available T₋₃₆ time point data. There were a total of 142 patients for which T₋₃₆ data was available from a combination of discovery and confirmatory data described above. Of these 142 patients, 79 were sepsis and 63 were SIRs. Computations were performed as described in further detail in Section 6.14.1. The calculations described above test 200 subcombinations at each interval 3 through 25. In other words, 200 subcombinations each consisting of three biomarkers randomly selected from Table I were tested, 200 subcombinations each consisting of four biomarkers randomly selected from Table I were tested, and so forth, through 200 subcombinations each consisting of twenty-five biomarkers randomly selected from Table I for a total of 23 families of subcombinations, where each family of subcombinations consists of 200 subcombinations of biomarkers each having k biomarkers, where k is a number in the set 3 through 25. FIG. 70 plots the accuracy of each of these 23 families of subcombinations as bar graphs. FIG. 71 plots the accuracy (performance) of each individual subcombination in each of the 23 families of subcombinations. Thus, FIG. 71 plots the accuracy (performance) of a total of 4600 subcombinations of the set of biomarkers listed in Table I.

[0714] FIGS. 70 and 71 indicate that for k>5, the distributions are Gaussian, (bell-shaped), indicating that each respective family (k=5, . . . , 25) is an accurate depiction of the subcombination space represented by the family. For k<=5, a handful of subsets give lower accuracy (performance) estimates. The results reported in FIGS. 70 and 71 show that, with as few as three biomarkers randomly selected from Table I, an

accuracy (performance) estimate above 50% was virtually always obtained. Table 99 contains the number of subcombinations in each family (k=3, 4, . . . , 25) that performed with a threshold accuracy of greater than 60% (column 2), greater than 70% (column 3), greater than 80% (column 4), greater than 90% (column 5), or an accuracy of less than 60% (column 6). The data summarized in FIGS. 70 and 71, as well as Table 99, demonstrate that, for time T₋₃₆ data, almost all subcombinations of biomarkers comprising between 3 and 25 biomarkers from Table I will discriminate between sepsis and SIRs subjects.

TABLE 99

Number of subcombinations from Table I that performed with a given threshold accuracy using T ₋₃₆ combined nucleic acid and protein data					
Column 1 Number of Biomarkers	Column 2 Greater than 60%	Column 3 Greater than 70%	Column 4 Greater than 80%	Column 5 Greater than 90%	Column 6 Less than 60%
3	187	96	4	0	13
4	199	127	5	0	1
5	200	145	7	0	0
6	200	149	9	0	0
7	200	148	9	0	0
8	200	157	8	0	0
9	200	175	13	0	0
10	199	179	7	0	1
11	200	180	11	0	0
12	200	175	11	0	0
13	200	184	15	0	0
14	200	184	10	0	0
15	200	180	5	0	0
16	200	190	17	0	0
17	200	191	16	0	0
18	200	190	15	0	0
19	200	191	8	0	0
20	200	196	13	0	0
21	200	198	15	0	0
22	200	195	9	0	0
23	200	195	14	0	0
24	200	195	10	0	0
25	200	196	18	0	0

6.15 Mean Expression Value of Biomarkers in Sepsis and SIRS Patients Identified in Table I

[0715] The mean expression values of the biomarkers of Table I were determined for subjects that acquired sepsis (Sepsis subjects) and subjects that did not acquire sepsis (SIRS subjects) in the populations described in Sections 6.11.2, 6.12.2 (Affymetrix data), 6.11.1, 6.12.1 (RT-PCR data), 6.1-3.3 (bead data), and 6.13.1 and 6.13.2 (bead data) at the T₋₁₂, T₋₃₆, and T₋₆₀ time points. This data is set forth in Table 100 below. In Table 100, a biomarker with the _Affy extension represents the combined data of Sections 6.11.2 and 6.11.2 (Affymetrix data), a biomarker with the 0.18S extension represents the combined data of Sections 6.11.1 and 6.12.1 (RT-PCR data), a biomarker with the BDB extension represents the data of Section 6.13.3, and a biomarker with the RBM extension represents the data of Sections 6.13.1 and 6.13.2.

[0716] For nucleic acid biomarkers in Table 100 that were identified by gene arrays (.Affy), the values in Table 100 represent mean relative fluorescence intensity units obtained for the specific probe sequences examined. As such, they are not actual units of measure, just relative quantity of one group to another. Additionally, as part of the data analysis, some of these values may have undergone a log transformation or

other adjustment, prior to being reported. The expression values for the nucleic acid biomarkers (0.18S) found in Table 100 are defined by the relative “cycle-time to threshold.” As such, they do not cite actual units of measure, just relative quantity of one group to another. A sample with a higher amount of nucleic acid will become positive sooner (fewer cycles) than one with less nucleic acid, which will require more cycles before the resultant signal crosses a positivity threshold. For the protein biomarkers in Table 101, the units

were as follows alphafetoprotein (AFP) $\mu\text{g/mL}$ (micrograms per milliliter of plasma), Beta-2-Microglobulin (B2M) $\mu\text{g/mL}$, Interleukin-6 (IL-6) pg/mL (picograms/milliliter), Interleukin-8 (IL-8) pg/mL , Interleukin-10 (IL-10) pg/mL , Monocyte Chemoattractant Protein 1 (MCP) pg/mL , Matrix Metalloproteinase 9 (MMP9) ng/mL (nanogram/milliliter), Tissue Inhibitor of Metalloproteinase 1 (TIMP 1) ng/mL (nanogram/mL), C Reactive protein (CRP) $\mu\text{g/mL}$, and Apolipoprotein CIII $\mu\text{g/mL}$.

TABLE 100

Mean expression values for the biomarkers of Table I as measured in the experimental Affymetrix, RT-PCR, and bead data of Section 6.						
Marker	SIRS T ₋₁₂	Sepsis T ₋₁₂	SIRS T ₋₃₆	Sepsis T ₋₃₆	SIRS T ₋₆₀	Sepsis T ₋₆₀
ANKRD22_Affy	8.33	9.72	8.28	9.27	8.51	9.17
ANXA3_Affy	10.06	11.28	10.19	11.197	10.49	11.14
BCL2A1_Affy	8.55	9.87	8.73	9.48	9.01	9.60
CCL5_Affy	11.69	11.30	11.73	11.22	11.49	11.29
CD86_Affy	8.59	8.10	8.68	8.13	8.57	8.20
CEACAM1_Affy	7.81	8.74	7.83	8.43	7.91	8.43
CRTAP_Affy	9.30	8.81	9.31	8.87	9.31	8.96
CSF1R_Affy	9.36	8.79	9.34	8.93	9.40	8.89
FAD104_Affy	7.89	8.63	8.04	8.39	8.18	8.36
FCGR1A_Affy	7.38	8.10	7.34	7.90	7.53	7.76
GADD45A_Affy	8.26	9.03	8.36	8.95	8.53	9.01
GADD45B_Affy	8.81	9.40	8.80	9.21	8.91	9.20
HLA.DRA_Affy	11.91	11.22	11.80	11.13	11.78	11.28
IFNGR1_Affy	11.20	11.51	11.25	11.53	11.38	11.52
IL18R1_Affy	6.65	8.23	6.81	7.90	7.00	7.95
INSL3_Affy	6.93	7.37	7.01	7.31	7.10	7.23
IRAK2_Affy	7.13	7.66	7.20	7.52	7.19	7.50
IRAK4_Affy	7.76	8.052	7.90	7.90	7.88	7.96
ITGAM_Affy	11.26	11.80	11.36	11.78	11.53	11.78
JAK2_Affy	6.85	7.523	7.02	7.35	7.08	7.38
LDLR_Affy	7.05	7.788	7.09	7.76	7.12	7.75
LY96_Affy	9.50	10.26	9.65	10.03	9.76	10.02
MAP2K6_Affy	8.261	9.17	8.49	9.02	8.59	9.05
MAPK14_Affy	8.75	9.75	8.99	9.51	9.16	9.48
MKKN1_Affy	10.02	10.59	10.07	10.50	10.30	10.60
Gene_MMP9_Affy	12.05	13.03	12.28	12.95	12.41	12.93
NCR1_Affy	5.64	5.94	5.645	5.90	5.77	5.91
OSM_Affy	6.70	7.51	6.79	7.25	7.00	7.32
PFKFB3_Affy	9.60	10.92	9.78	10.83	10.18	10.82
PRV1_Affy	9.79	11.99	9.89	11.81	10.58	11.72
PSTPIP2_Affy	8.63	9.64	8.68	9.45	8.90	9.44
SOCS3_Affy	7.26	8.43	7.31	8.10	7.69	8.12
SOD2_Affy	9.94	10.66	10.07	10.69	10.27	10.59
TDRD9_Affy	6.84	8.30	7.02	8.30	7.43	8.18
TGFBI_Affy	10.17	9.31	10.27	9.45	10.37	9.63
TIFA_Affy	5.99	6.51	5.94	6.31	6.01	6.27
TNFSF10_Affy	10.38	10.77	10.51	10.56	10.47	10.52
TNFSF13B_Affy	10.23	10.70	10.24	10.56	10.48	10.58
IL10alpha_Affy	9.91	9.53	9.87	9.56	9.91	9.63
ANKRD22.18S	20.35	18.33	20.31	18.65	20.01	18.70
ANXA3.18S	17.29	15.52	17.00	15.50	16.78	15.68
ARG2.18S	20.36	19.09	20.12	19.26	19.93	19.13
BCL2A1.18S	18.58	17.00	18.20	17.05	17.84	17.04
CD86.18S	19.81	20.19	19.70	20.15	19.68	20.10
CEACAM1.18S	19.98	18.34	19.84	18.39	19.73	18.36
FCGR1A.18S	16.78	15.03	16.51	15.32	16.329	15.59
GADD45A.18S	19.73	18.46	19.69	18.45	19.38	18.53
GADD45B.18S	16.72	15.52	16.61	15.65	16.50	15.86
IFNGR1.18S	16.00	15.23	15.77	15.20	15.68	15.23
IL1RN.18S	17.24	16.01	17.03	16.05	16.95	16.27
IL18R1.18S	20.56	18.71	20.15	18.72	20.04	18.72
INSL3.18S	21.41	20.03	21.22	20.01	21.00	20.22
IRAK2.18S	20.45	19.20	20.28	19.29	20.32	19.49
IRAK4.18S	18.25	17.74	18.06	17.65	17.98	17.71
ITGAM.18S	15.45	14.51	15.27	14.57	15.12	14.60
JAK2.18S	17.77	16.90	17.56	16.97	17.50	17.06
LDLR.18S	20.34	19.31	20.19	19.10	20.28	19.24
LY96.18S	19.24	18.20	18.95	18.27	18.75	18.35

TABLE 100-continued

Mean expression values for the biomarkers of Table I as measured in the experimental Affymetrix, RT-PCR, and bead data of Section 6.						
Marker	SIRS T ₋₁₂	Sepsis T ₋₁₂	SIRS T ₋₃₆	Sepsis T ₋₃₆	SIRS T ₋₆₀	Sepsis T ₋₆₀
MAP2K6.18S	18.11	16.78	17.86	16.62	17.73	16.74
MKMK1.18S	17.61	16.48	17.37	16.48	17.22	16.58
Gene_MMP9.18S	14.89	13.40	14.70	13.27	14.53	13.15
NCR1.18S	21.89	21.06	21.79	20.99	21.82	21.11
OSM.18S	19.98	18.41	19.71	18.51	19.49	18.57
PFKFB3.18S	17.83	15.86	17.53	15.85	17.18	16.00
PRV1.18S	16.87	13.49	16.28	13.08	15.42	13.34
PSTPIP2.18S	17.45	16.18	17.24	16.31	17.13	16.37
SOCS3.18S	16.83	15.09	16.57	15.12	16.20	15.30
SOD2.18S	13.62	12.83	13.50	12.87	13.41	13.12
TDRD9.18S	22.65	20.64	22.32	20.45	21.95	20.57
TIFA.18S	19.02	17.40	18.89	17.69	18.70	17.97
TLR4.18S	17.93	17.03	17.83	17.24	17.73	17.33
TNFRSF6.18S	17.31	16.51	17.02	16.74	17.05	16.88
TNFSF10.18S	16.21	15.32	15.98	15.49	16.00	15.68
TNFSF13B.18S	16.32	15.43	16.16	15.72	16.01	15.71
VNN1.18S	17.16	15.39	16.70	15.19	16.51	15.12
AlphaFetoprotein_RBM	3.77	4.22	3.70	4.34	3.34	4.01
Apolipoprotein_CIII_RBM	59.72	38.05	53.84	38.34	53.38	40.03
Beta2Microglobulin_RBM	2.83	3.63	2.57	3.02	2.43	2.89
CReactiveProtein_RBM	146.95	261.16	206.21	258.20	171.76	245.76
IL6_RBM	82.87	4858.72	99.21	308.50	98.28	341.38
IL8_RBM	31.03	121.58	36.78	78.93	30.15	69.30
IL10_RBM	21.92	64.45	33.16	38.60	21.12	37.43
MCP1_RBM	237.84	796.87	259.82	505.33	229.04	558.73
Protein_MMP9_RBM	1143.25	1809.30	992.84	1390.05	961.12	1364.40
TIMP1_RBM	226.68	406.90	237.22	351.29	235.05	344.12
ARG2_SPM	21.34	20.25	21.30	20.43	21.32	20.56
CD86_SPM	17.31	17.95	17.47	17.90	17.53	17.87
FCGR1A_SPM	16.16	14.48	15.98	14.85	15.80	15.13
IL1RN_SPM	15.75	14.81	15.59	14.95	15.55	15.10
IL6_SPM	23.58	23.55	23.71	23.67	23.70	23.58
IL8_SPM	21.97	21.99	22.46	22.48	22.68	22.41
IL10_SPM	21.15	20.02	21.10	20.26	20.96	20.24
IL18R1_SPM	18.33	16.54	18.06	16.75	18.04	16.83
ITGAM_SPM	14.66	13.82	14.37	13.84	14.37	13.96
Gene_MMP9_SPM	13.14	11.71	12.90	11.82	13.01	11.95
TIMP1_SPM	13.57	13.00	13.38	12.95	13.47	13.02
TLR4_SPM	14.86	14.22	14.80	14.35	14.71	14.41
TNFSF13B_SPM	14.63	13.91	14.56	14.13	14.52	14.21
CReactiveProtein_SPM	23.19	23.00	23.26	23.20	23.27	23.25
IL6_BDB	-0.15	0.59	-0.25	-0.02	-0.19	0.147
IL8_BDB	-0.24	0.74	-0.30	0.24	-0.32	0.20
IL10_BDB	-0.18	0.57	-0.27	0.35	-0.20	0.10
MCP1_BDB	-0.18	0.58	-0.18	0.01	-0.25	0.20

[0717] The range of expression values of the biomarkers of Table I were determined for subjects that acquired sepsis (Sepsis subjects) and subjects that did not acquire sepsis (SIRS subjects) in the populations described in Sections 6.11.2, 6.12.2 (Affymetrix data), 6.11.1, 6.12.1 (RT-PCR data), 6.1-3.3 (bead data), and 6.13.1 and 6.13.2 (bead data) at the T₋₁₂ and T₋₃₆ time points. This data is set forth in Table 101 below. In Table 101, a biomarker with the _Affy extension represents the combined data of Sections 6.11.2 and 6.11.2 (Affymetrix

data), a biomarker with the 0.18S extension represents the combined data of Sections 6.11.1 and 6.12.1 (RT-PCR data), a biomarker with the BDB extension represents the data of Section 6.13.3, and a biomarker with the RBM extension represents the data of Sections 6.13.1 and 6.13.2. Time points are given in column 6, where T-12 represents the T₋₁₂ time point, and T-36 represents the T₋₃₆ time point. Units in Table 101 are as described for Table 100.

TABLE 101

Expression value ranges for the biomarkers of Table I as measured in the experimental Affymetrix, RT-PCR, and bead data of Section 6.

Biomarker	Minimum value in sepsis subjects	Maximum value in sepsis subjects	Minimum value in SIRS subjects	Maximum value in SIRS subjects	Time
1	2	3	4	5	6
ANKRD22_Affy	7.953749641	12.12893617	7.152671629	11.15686619	T-12
ANXA3_Affy	8.694223626	12.60070358	7.888396707	11.77082747	T-12
BCL2A1_Affy	7.44669819	11.98497181	6.831314584	10.15766376	T-12
CCL5_Affy	8.898803629	12.84470384	10.18676932	12.76079187	T-12
CD86_Affy	7.053070944	9.279967603	7.868508261	9.428684419	T-12
CEACAM1_Affy	7.392836443	10.11429986	6.897178024	8.990696622	T-12
CRTAP_Affy	7.96569575	10.04792044	8.402744052	10.11557268	T-12
CSF1R_Affy	8.12973354	9.802040206	8.308888545	10.10429638	T-12
FAD104_Affy	7.670795141	10.63246961	5.857923276	9.290926038	T-12
FCGR1A_Affy	6.796282224	9.51719797	6.335911956	9.135545399	T-12
GADD45A_Affy	7.874842459	10.63426409	6.244572007	9.859106279	T-12
GADD45B_Affy	8.479965651	10.29001883	7.992247915	9.49903678	T-12
HLA.DRA_Affy	9.174921757	12.40164437	10.91664573	12.59721891	T-12
IFNGR1_Affy	9.881934243	12.20352664	10.20622485	12.04433802	T-12
IL18R1_Affy	5.617961135	10.58599306	5.401354816	8.680200674	T-12
INSL3_Affy	6.498476621	8.453102101	6.380834209	7.658960107	T-12
IRAK2_Affy	6.875497116	9.68130844	6.749722992	8.274075293	T-12
IRAK4_Affy	7.433778424	8.878566727	7.144224029	8.232236692	T-12
ITGAM_Affy	10.49945783	12.40537329	10.40124379	12.02696288	T-12
JAK2_Affy	5.855248527	8.799277378	5.832795685	7.719583127	T-12
LDLR_Affy	6.257275326	9.674292614	6.131286337	7.912581783	T-12
LY96_Affy	8.415332968	11.70570487	8.133946247	10.62910735	T-12
MAP2K6_Affy	7.596722579	10.56652274	7.340508485	9.871737402	T-12
MAPK14_Affy	8.070466208	10.92164826	7.114917424	10.02925699	T-12
MKINK1_Affy	9.279266935	11.72051891	8.987912062	11.32996284	T-12
Gene_MMP9_Affy	11.53180146	14.23119077	10.53501559	13.54148736	T-12
NCR1_Affy	5.317900783	6.518234278	5.112152822	6.108537679	T-12
OSM_Affy	6.711016689	8.50414686	5.914544406	7.870308905	T-12
PFKFB3_Affy	8.872516729	12.35520872	8.119052014	11.65471067	T-12
PRV1_Affy	8.247231438	14.06000214	7.787420639	12.82213193	T-12
PSTPIP2_Affy	7.917121337	10.93727651	7.633999161	10.56933315	T-12
SOCS3_Affy	6.800978821	10.18734767	6.095547925	8.999643638	T-12
SOD2_Affy	9.638778614	11.7873112	8.477270195	11.33496413	T-12
TDRD9_Affy	5.982800228	10.55761021	5.394035579	9.208195372	T-12
TGFBI_Affy	7.954609344	11.19226116	8.973848308	11.1560402	T-12
TIFA_Affy	5.620694754	8.03295421	5.430693745	7.140866404	T-12
TNFSF10_Affy	9.847323138	11.63713214	9.035999538	11.33035464	T-12
TNFSF13B_Affy	8.585414556	11.79818987	8.90534601	11.34212616	T-12
IL10alpha_Affy	8.690880784	10.54878771	9.024669305	10.52469989	T-12
ANKRD22.18S	14.554	20.607	18.026	22.621	T-12
ANXA3.18S	12.994	18.89	14.989	20.069	T-12
ARG2.18S	16.703	22.511	17.729	23.054	T-12
BCL2A1.18S	14.219	19.664	15.565	20.206	T-12
CD86.18S	18.391	22.429	18.245	21.426	T-12
CEACAM1.18S	15.174	20.37	16.808	21.929	T-12
FCGR1A.18S	12.273	17.502	14.289	19.097	T-12
GADD45A.18S	15.697	20.631	18.602	21.118	T-12
GADD45B.18S	14.214	17.599	15.52	18.143	T-12
IFNGR1.18S	13.746	17.418	14.233	17.389	T-12
IL1RN.18S	13.7	18.656	14.995	19.231	T-12
IL18R1.18S	15.6	21.649	16.63	23.144	T-12
INSL3.18S	18.077	22.515	19.735	23.106	T-12
IRAK2.18S	16.851	21.205	17.775	22.286	T-12
IRAK4.18S	16.637	19.164	17.001	19.648	T-12
ITGAM.18S	12.6	17.346	13.709	17.172	T-12
JAK2.18S	15.292	19.228	16.431	19.001	T-12
LDLR.18S	16.909	21.4	18.195	22.081	T-12
LY96.18S	16.811	20.726	17.543	20.956	T-12
MAP2K6.18S	14.062	18.942	16.2005	20.678	T-12
MKINK1.18S	14.677	18.261	15.589	19.195	T-12
Gene_MMP9.18S	10.128	16.281	12.644	17.265	T-12
NCR1.18S	18.175	23.462	19.544	23.756	T-12
OSM.18S	16.6	20.544	17.835	22.174	T-12
PFKFB3.18S	12.897	18.994	14.446	20.982	T-12
PRV1.18S	9.4745	19.6	11.749	23.823	T-12
PSTPIP2.18S	14.243	18.013	16.098	18.792	T-12
SOCS3.18S	13.312	18.094	14.603	18.51	T-12

TABLE 101-continued

Expression value ranges for the biomarkers of Table I as measured in the experimental Affymetrix, RT-PCR, and bead data of Section 6.					
Biomarker	Minimum value in sepsis subjects	Maximum value in sepsis subjects	Minimum value in SIRS subjects	Maximum value in SIRS subjects	Time
1	2	3	4	5	6
SOD2.18S	10.822	14.875	11.836	15.269	T-12
TDRD9.18S	17.069	23.9	20.012	25.404	T-12
TIFA.18S	14.66	20.607	16.122	20.522	T-12
TLR4.18S	15.013	19.366	15.452	19.347	T-12
TNFRSF6.18S	14.771	18.42	16.046	18.633	T-12
TNFSF10.18S	14.175	16.71	14.913	18.005	T-12
TNFSF13B.18S	13.296	17.2755	14.113	18.23	T-12
VNN1.18S	12.363	19.695	14.788	20.209	T-12
AlphaFetoprotein_RBM	0.465	28.9	0.862	15	T-12
ApolipoproteinCIII_RBM	9.1	104	14	170	T-12
Beta2Microglobulin_RBM	0.912	17	0.815	14.2	T-12
CReactiveProtein_RBM	5.2	743	9.3	435	T-12
IL6_RBM	11.9	350000	5.85	1090	T-12
IL8_RBM	5.7	2430	4.6	136	T-12
IL10_RBM	9.4	1080	6.73	115	T-12
MCP1_RBM	68	20100	54	1860	T-12
Protein_MMP9_RBM	82.7	6100	37	5500	T-12
TIMP1_RBM	99.6	1670	91.7	777	T-12
ARG2_SPM	18.19	22.88	19.11	23.53	T-12
CD86_SPM	16.51	20.02	15.83	18.57	T-12
FCGR1A_SPM	11.78	16.69	13.448	18.43	T-12
IL1RN_SPM	12.82	17.055	12.92	17.13	T-12
IL6_SPM	22.71	24.493	22.61	24.22	T-12
IL8_SPM	17.728	23.645	19.218	24.27	T-12
IL10_SPM	16.905	22.09	17.41	23.38	T-12
IL18R1_SPM	13.69	19.36	13.628	20.7	T-12
ITGAM_SPM	12.33	16.26	12.21	16.24	T-12
Gene_MMP9_SPM	8.53	14.62	9.58	15.92	T-12
TIMP1_SPM	11.63	15.048	11.71	14.93	T-12
TLR4_SPM	12.5	16.64	13.61	16.06	T-12
TNFSF13B_SPM	12.29	15.86	12.37	15.998	T-12
CReactiveProtein_SPM	16.23	24.313	18.803	24.245	T-12
IL6_BDB	-0.158501071	12.45941145	-0.166932601	-0.076083727	T-12
IL8_BDB	-0.260734671	10.31273265	-0.284430649	-0.128681359	T-12
IL10_BDB	-0.317504403	4.487381808	-0.541755786	0.071431589	T-12
MCP1_BDB	-0.215354271	11.61107183	-0.231122309	-0.10084064	T-12
IL6_CBA	-0.674647421	5.170323126	-0.825867097	-0.022530263	T-12
IL8_CBA	-0.620553789	5.923519248	-0.821374574	2.902006709	T-12
IL10_CBA	-0.661588916	4.74196577	-0.730146126	6.047793474	T-12
ANKRD22_Affy	7.396771628	11.57062629	7.129021339	9.443944368	T-36
ANXA3_Affy	8.70013622	12.54023119	8.331913923	12.10925762	T-36
BCL2A1_Affy	7.183882918	11.76715511	6.405590222	10.37097944	T-36
CCL5_Affy	9.328902305	12.61675161	10.40637568	12.86027708	T-36
CD86_Affy	6.732706362	9.538835708	7.716006192	9.498278669	T-36
CEACAM1_Affy	7.13157116	9.873881135	7.032079139	9.080997559	T-36
CRTAP_Affy	7.558590076	9.700256103	8.59265066	10.03618173	T-36
CSF1R_Affy	7.837660302	9.949036275	8.464494614	10.30550413	T-36
FAD104_Affy	7.014972123	10.15391937	6.239710352	8.845757597	T-36
FCGR1A_Affy	6.911908197	9.049485977	6.738241369	8.397213121	T-36
GADD45A_Affy	7.56337487	10.85396197	6.589642416	9.749741171	T-36
GADD45B_Affy	8.51689696	10.06660743	8.254872004	9.532337644	T-36
HLA.DRA_Affy	9.633249373	12.27644605	10.46875169	12.67263889	T-36
IFNGR1_Affy	10.57959732	12.27228887	9.808984607	11.81736908	T-36
IL18R1_Affy	5.49992437	10.36284472	5.348365647	9.056683263	T-36
INSL3_Affy	6.751235769	8.470974618	6.354223568	7.671828775	T-36
IRAK2_Affy	6.667783945	8.746281062	6.803703241	7.823003239	T-36
IRAK4_Affy	7.263029682	8.81320843	7.431560803	8.530795242	T-36
ITGAM_Affy	10.78220173	12.65177246	10.81608481	11.95316198	T-36
JAK2_Affy	6.39933742	8.609398755	6.113876348	7.761009287	T-36
LDLR_Affy	6.592115082	9.576882573	6.429539125	7.875471828	T-36
LY96_Affy	8.653718448	11.10873698	7.823465941	10.99470657	T-36
MAP2K6_Affy	7.76590836	10.96462704	7.656234297	9.824692325	T-36
MAPK14_Affy	8.115337243	10.65189637	8.035017587	10.2553217	T-36
MKNK1_Affy	9.648189763	11.7078247	9.01371136	10.87910413	T-36
Gene_MMP9_Affy	11.11827617	14.10554558	11.20801397	13.49402871	T-36
NCRI_Affy	5.193987983	6.909045684	5.005834897	6.207479976	T-36
OSM_Affy	6.580322029	7.935265514	6.196973735	7.452713795	T-36

TABLE 101-continued

Expression value ranges for the biomarkers of Table I as measured in the experimental Affymetrix, RT-PCR, and bead data of Section 6.					
Biomarker	Minimum value in sepsis subjects	Maximum value in sepsis subjects	Minimum value in SIRS subjects	Maximum value in SIRS subjects	Time
1	2	3	4	5	6
PFKFB3_Affy	9.424977102	12.34048574	8.499191685	11.18985748	T-36
PRV1_Affy	8.075175165	13.89885359	7.885024966	13.11270704	T-36
PSTPIP2_Affy	8.014852906	10.87208092	7.546671853	9.463070109	T-36
SOCS3_Affy	7.377913606	9.55384035	6.2535144	8.311473326	T-36
SOD2_Affy	9.246088148	11.68031375	9.036280605	11.01924042	T-36
TDRD9_Affy	6.248252454	11.18511333	5.639880173	9.344436192	T-36
TGFBI_Affy	7.994695342	11.02064264	9.079527674	11.18636937	T-36
TIFA_Affy	5.521978531	7.303421302	5.384514217	6.593248984	T-36
TNFSF10_Affy	9.60197872	11.18227009	9.614398352	11.21902779	T-36
TNFSF13B_Affy	9.376572388	11.47004606	8.423154647	11.14896209	T-36
IL10alpha_Affy	8.838180931	10.20810676	9.056040579	10.61188847	T-36
ANKRD22.18S	16.059	21.635	18.344	22.188	T-36
ANXA3.18S	13.508	18.565	14.637	19.196	T-36
ARG2.18S	16.7215	22.085	16.452	23.1025	T-36
BCL2A1.18S	14.892	20.169	15.558	21.208	T-36
CD86.18S	18.109	22.671	17.734	21.408	T-36
CEACAM1.18S	15.864	20.381	17.141	21.711	T-36
FCGR1A.18S	12.919	17.238	13.773	18.616	T-36
GADD45A.18S	16.021	20.468	17.567	21.221	T-36
GADD45B.18S	14.051	16.799	15.43	18.189	T-36
IFNGR1.18S	13.89	16.44	14.532	17.1035	T-36
IL1RN.18S	14.2965	18.584	14.569	18.818	T-36
IL18R1.18S	15.6475	21.683	17.068	21.9465	T-36
INSL3.18S	18.708	21.952	19.775	23.714	T-36
IRAK2.18S	17.563	20.591	18.878	21.765	T-36
IRAK4.18S	16.688	18.592	16.633	19.467	T-36
ITGAM.18S	12.974	16.862	12.696	16.597	T-36
JAK2.18S	15.659	18.42	16.185	18.67	T-36
LDLR.18S	16.925	20.765	18.764	21.351	T-36
LY96.18S	17.018	20.384	17.293	21.37	T-36
MAP2K6.18S	14.375	19.44	15.5485	20.507	T-36
MKMK1.18S	15.064	17.922	15.281	19.103	T-36
Gene_MMP9.18S	10.4315	16.075	12.673	16.9025	T-36
NCR1.18S	18.189	22.531	20.01	23.281	T-36
OSM.18S	16.79	20.311	18.219	21.612	T-36
PFKFB3.18S	13.095	18.678	14.042	19.647	T-36
PRV1.18S	9.732	18.921	10.63	20.57	T-36
PSTPIP2.18S	14.568	17.943	15.363	18.848	T-36
SOCS3.18S	13.309	16.962	14.629	18.503	T-36
SOD2.18S	11.004	15.117	12.246	14.872	T-36
TDRD9.18S	17.108	22.863	19.203	24.013	T-36
TIFA.18S	15.498	20.069	16.808	20.769	T-36
TLR4.18S	15.77	19.352	15.578	19.604	T-36
TNFRSF6.18S	14.782	17.867	15.952	18.014	T-36
TNFSF10.18S	14.049	16.332	14.388	17.196	T-36
TNFSF13B.18S	13.898	16.896	13.276	18.038	T-36
VNN1.18S	12.406	18.076	13.061	20.4895	T-36
AlphaFetoprotein_RBM	0.0878	45.2	0.399	14	T-36
ApolipoproteinCIII_RBM	8.1	105	17	143	T-36
Beta2Microglobulin_RBM	0.857	13.4	0.953	10.6	T-36
CReactiveProtein_RBM	9.3	548	45	735	T-36
IL6_RBM	8.93	6140	5.85	1480	T-36
IL8_RBM	2.4	977	2.5	429	T-36
IL10_RBM	2.68	397	4.4	760	T-36
MCP1_RBM	77	4280	60	2170	T-36
Protein_MMP9_RBM	59	9000	73	3840	T-36
TIMP1_RBM	89.9	1130	85.2	1050	T-36
ARG2_SPM	17.868	23.15	17.68	23.42	T-36
CD86_SPM	16.15	20.528	16.36	18.78	T-36
FCGR1A_SPM	12.53	17.43	13.633	17.868	T-36
IL1RN_SPM	13.375	17.043	13.98	17.695	T-36
IL6_SPM	23.12	24.378	23.17	24.46	T-36
IL8_SPM	20.33	23.78	19.38	24.24	T-36
IL10_SPM	16.785	23.34	18.648	23.63	T-36
IL18R1_SPM	14.16	19.13	15.98	19.68	T-36
ITGAM_SPM	12.55	15.84	12.683	15.79	T-36
Gene_MMP9_SPM	9.163	15	10.66	14.91	T-36

TABLE 101-continued

Expression value ranges for the biomarkers of Table I as measured in the experimental Affymetrix, RT-PCR, and bead data of Section 6.					
Biomarker	Minimum value in sepsis subjects	Maximum value in sepsis subjects	Minimum value in SIRS subjects	Maximum value in SIRS subjects	Time
1	2	3	4	5	6
TIMP1_SPM	11.53	14.895	11.77	15.08	T-36
TLR4_SPM	13.2	15.91	13.52	16	T-36
TNFSF13B_SPM	12.56	15.415	13.19	16.725	T-36
CReactiveProtein_SPM	19.6	23.97	20.8	24	T-36
IL6_BDB	-0.684465464	2.880494108	-0.730942369	1.994658691	T-36
IL8_BDB	-0.825836521	3.74397758	-1.025991342	0.789180774	T-36
IL10_BDB	-1.371058252	8.324182809	-1.079489666	2.72772331	T-36
MCP1_BDB	-0.80163532	2.625526703	-0.828696306	2.820125749	T-36

7. REFERENCES CITED

[0718] The present invention can be implemented as a computer program product that comprises a computer program mechanism embedded in a computer readable storage medium. For instance, the computer program product could contain the program modules shown in FIG. 35. These program modules can be stored on a CD-ROM, DVD, magnetic disk storage product, or any other computer readable data or program storage product. The program modules can also be embedded in permanent storage, such as ROM, one or more programmable chip, or one or more application specific integrated circuits (ASICs). Such permanent storage can be localized in a server, 802.11 access point, 802.11 wireless bridge/station, repeater, router, mobile phone, or other electronic devices. The software modules in the computer program product can also be distributed electronically, via the Internet or otherwise, by transmission of a computer data signal (in which the software modules are embedded) either digitally or on a carrier wave.

[0719] Having now fully described the invention with reference to certain representative embodiments and details, it will be apparent to one of ordinary skill in the art that changes and modifications can be made thereto without departing from the spirit or scope of the invention as set forth herein. The specific embodiments described herein are offered by way of example only, and the invention is to be limited only by the terms of the appended claims, along with the full scope of equivalents to which such claims are entitled.

1.-113. (canceled)

114. A method of predicting an increased likelihood of developing sepsis in a human SIRS patient comprising:

obtaining a first blood sample from said patient, said sample comprising biomarker mRNAs;

measuring the abundances of said biomarker mRNAs in said first blood sample taken from said patient, wherein said biomarker mRNAs comprise Major Histocompatibility Complex, Class II, DR Alpha (HLA-DRA) mRNA and mRNAs from at least four other biomarkers listed in Table J;

comparing said abundances of said biomarker mRNAs in said first blood sample to abundances of said biomarker mRNAs in (i) blood samples taken 0-36 hours prior to sepsis development in a SIRS-positive human patient population that progresses to sepsis, and (ii) blood

samples taken from a SIRS-positive human patient population that does not progress to sepsis;

wherein an increased likelihood of developing sepsis is predicted in the SIRS patient when it is determined that the biomarker mRNA abundances in the first blood sample are statistically significantly similar to the biomarker mRNA abundances in the blood samples taken from the SIRS-positive human patient population that progresses to sepsis;

wherein a decreased likelihood of developing sepsis is predicted in the SIRS patient when it is determined that the mRNA abundances in the first blood sample are statistically significantly similar to the mRNA abundances in the blood samples taken from the SIRS-positive human patient population that does not progress to sepsis; and

wherein said SIRS-positive human patient population that progresses to sepsis and said SIRS-positive human patient population that does not progress to sepsis each comprises at least 20 individuals.

115. The method of claim 114, wherein said biomarker mRNAs comprise a combination of biomarker mRNAs selected from the combinations consisting of:

GADD45B, PFKFB3, PSTPIP2, FCGR1A, HLA-DRA, ARG2;

HLA-DRA, INSL3, ARG2, CD86, CCL5, SOCS3;

GADD45A, PSTPIP2, BCL2A1, ANKRD22, HLA-DRA, ANXA3;

INSL3, NCR1, PSTPIP2, PFKFB3, ANKRD22, HLA-DRA, MKNK1;

FCGR1A, HLA-DRA, CSF1R, SOCS3, IRAK4, TIFA, ARG2;

LDLR, INSL3, GADD45B, ARG2, PFKFB3, HLA-DRA, ITGAM;

IRAK4, INSL3, CSF1R, ITGAM, VNN1, HLA-DRA, IL18R1;

ANXA3, TNFSF10, CEACAM1, FCGR1A, HLA-DRA, IL10alpha, 12, SOCS3;

HLA-DRA, CEACAM1, IFNGR1, MKNK1, LDLR, GADD45B, 12, CSF1R;

FAD104, MAPK14, IFNGR1, IL18R1, TNFSF10, CD86, 12, HLA-DRA;

TIFA, IL1RN, MAP2K6, HLA-DRA, OSM, FAD104, 12, INSL3;

JAK2, IRAK2, PRV1, TNFSF13B, OSM, HLA-DRA, 12, IFNGR1;
PRV1, TLR4, CSF1R, IL18R1, PSTPIP2, TDRD9, 12, HLA-DRA;
ANKRD22, HLA-DRA, PRV1, NCR, CSF1R, PSTPIP2, 12, LY96;
INSL3, ARG2, LDLR, HLA-DRA, NCR1, TIFA, LY96, ITGAM, SOCS3;
CD86, CSF1R, SOD2, OSM, SOCS3, BCL2A1, GADD45B, ARG2, HLA-DRA;
ARG2, CD86, MAP2K6, HLA-DRA, IL10alpha, IRAK2, GADD45B, MKNK1, IL18R1;
GADD45B, ITGAM, PRV1, SOD2, TNFSF13B, HLA-DRA, FAD104, TNFRSF6, TLR4;
HLA-DRA, GADD45A, FCGR1A, ANKRD22, ARG2, NCR, BCL2A1, IRAK2, SOCS3;
IL18R1, CSF1R, IRAK2, HLA-DRA, PFKFB3, CRTAP, CD86, TIFA, TNFSF10;
PSTPIP2, ANKRD22, TNFSF10, INSL3, HLA-DRA, NCR, TNFSF13B, CSF1R, Gene_MMP9;
PSTPIP2, ANKRD22, TNFSF10, INSL3, HLA-DRA, NCR1, TNFSF13B, CSF1R, Gene_MMP9;
SOD2, PRV1, MKNK1, FCGR1A, CD86, GADD45A, IL18R1, TNFSF13B, HLA-DRA;
NCR1, SOCS3, HLA-DRA, PFKFB3, FAD104, IRAK4, VNN1, CCL5, MAP2K6;
CRTAP, ARG2, SOD2, TDRD9, TNFRSF6, TIFA, OSM, Gene_MMP9, HLA-DRA;
TNFSF13B, JAK2, IRAK4, TDRD9, HLA-DRA, SOCS3, PSTPIP2, FAD104, SOD2;
Gene_MMP9, SOD2, JAK2, CD86, HLA-DRA, IRAK2, CEACAM1, MAPK14, ANXA3;
GADD45B, ITGAM, TLR4, NCR, CD86, TNFSF13B, HLA-DRA, FCGR1A, OSM;
NCR1, HLA-DRA, BCL2A1, ARG2, SOCS3, IL18R1, PSTPIP2, VNN1, CD86, GADD45A, CCL5;
TGFB1, SOCS3, MAP2K6, ANXA3, TLR4, IL1RN, VNN1, HLA-DRA, TIFA, JAK2, TDRD9;
CRTAP, TNFRSF6, LDLR, VNN1, HLA-DRA, SOCS3, TGFB1, TNFSF10, IFNGR1, ARG2, FCGR1A;
HLA-DRA, BCL2A1, PSTPIP2, PFKFB3, JAK2, TNFSF10, ARG2, CEACAM1, IL18R1, MAPK14, CSF1R;
GADD45B, TNFSF10, TNFSF13B, OSM, VNN1, PRV1, MKNK1, Gene_MMP9, ANXA3, TGFB1, HLA-DRA;
VNN1, SOD2, CCL5, BCL2A1, HLA-DRA, ANKRD22, CD86, TDRD9, TLR4, FCGR1A, TNFSF10;
CSF1R, ITGAM, HLA-DRA, MAP2K6, JAK2, FCGR1A, OSM, LDLR, SOCS3, TNFRSF6, IL18R1;
OSM, GADD45A, TNFSF10, IFNGR1, CRTAP, JAK2, ANKRD22, HLA-DRA, TNFSF13B, SOCS3, FCGR1A;
CCL5, CD86, HLA-DRA, SOCS3, TGFB1, PSTPIP2, ANXA3, GADD45A, CSF1R, IRAK4, FAD104, MAPK14;
TNFRSF6, IL10alpha, PSTPIP2, HLA-DRA, CRTAP, ARG2, MKNK1, NCR1, OSM, INSL3, VNN1, FAD104;
FCGR1A, HLA-DRA, IFNGR1, CD86, LY96, ANXA3, MAP2K6, TDRD9, IL18R1, PRV1, SOCS3, TIFA;
LDLR, MAP2K6, INSL3, TDRD9, NCR1, IL1RN, HLA-DRA, ARG2, MKNK1, MAPK14, OSM, PFKFB3;
LY96, TNFSF13B, HLA-DRA, IRAK2, FCGR1A, ANXA3, CEACAM1, FAD104, TDRD9, IL1RN, ARG2, LDLR;
OSM, NCR1, HLA-DRA, TNFRSF10, PSTPIP2, IL1RN, SOCS3, INSL3, TNFRSF6, MAPK14, Gene_MMP9, CEACAM1, IL18R1;
SOD2, JAK2, PSTPIP2, MAPK14, MAP2K6, FCGR1A, CCL5, ITGAM, CD86, GADD45B, IL1RN, HLA-DRA, VNN1;
IRAK4, JAK2, SOD2, Gene_MMP9, PSTPIP2, PFKFB3, HLA-DRA, TNFRSF6, FAD104, ARG2, IFNGR1, IRAK2, MAP2K6;
PSTPIP2, MAPK14, CCL5, Gene_MMP9, TNFRSF6, IL10alpha, LY96, IL1RN, ARG2, SOCS3, TLR4, OSM, HLA-DRA;
TGFB1, IL1RN, INSL3, PSTPIP2, NC, FAD104, HLA-DRA, CD86, IRAK4, IL10alpha, ARG2, CSF1R, MAP2K6;
GADD45A, HLA-DRA, INSL3, ANKRD22, ANXA3, CD86, IRAK4, GADD45B, PFKFB3, ITGAM, VNN1, NCR1, JAK2;
IFNGR1, TLR4, CRTAP, ANKRD22, Gene_MMP9, JAK2, INSL3, ITGAM, IRAK4, HLA-DRA, BCL2A1, OSM, TNFSF10, NCR;
CD86, FCGR1A, MKNK1, TNFRSF6, GADD45B, LY96, NCR, PSTPIP2, HLA-DRA, VNN1, ANXA3, IRAK4, ARG2, TGFB1;
ARG2, ANKRD22, OSM, LDLR, CCL5, IL1RN, FCGR1A, PFKFB3, CSF1R, ANXA3, HLA-DRA, INSL3, NCR1, TIFA;
TLR4, MKNK1, SOD2, SOCS3, FAD104, HLA-DRA, PSTPIP2, ANKRD22, TIFA, TNFRSF6, JAK2, TNFSF10, ARG2, CSF1R, TLR4;
TLR4, MKNK1, SOD2, SOCS3, FAD104, HLA-DRA, PSTPIP2, ANKRD22, TIFA, TNFRSF6, JAK2, TNFSF10, ARG2, CSF1R, IRAK4;
NCR1, INSL3, HLA-DRA, TNFSF10, TNFRSF6, FCGR1A, OSM, GADD45B, MKNK1, TNFSF13B, CSF1R, LY96, MAPK14, PRV1, CCL5;
IRAK2, IL10alpha, INSL3, FAD104, TIFA, SOD2, IFNGR1, IL1RN, HLA-DRA, LY96, IL18R1, CCL5, CD86, TDRD9, TNFSF10;
SOD2, IFNGR1, CEACAM1, OSM, FAD104, HLA-DRA, CRTAP, IL10alpha, TGFB1, GADD45A, ITGAM, IL18R1, CCL5, TLR4, FCGR1A;
MKNK1, CRTAP, PRV1, IL1RN, GADD45A, TNFRSF6, FAD104, HLA-DRA, CEACAM1, PSTPIP2, OSM, JAK2, IL18R1, LDLR, IRAK4;
FCGR1A, BCL2A1, IFNGR1, CRTAP, VNN1, TIFA, CCL5, NCR1, OSM, HLA-DRA, IRAK4, INSL3, MAP2K6, TNFSF13B, ARG2;
HLA-DRA, IRAK2, FCGR1A, ANXA3, ITGAM, LY96, TDRD9, SOCS3, IL1RN, PFKFB3, GADD45B, TNFSF13B, TLR4, ARG2, CSF1R, FAD104;
GADD45A, CSF1R, INSL3, BCL2A1, TDRD9, LDLR, HLA-DRA, MAP2K6, PSTPIP2, CCL5, ANXA3, PRV1, TNFRSF6, TLR4, CD86, JAK2;
TNFSF10, PRV1, SOCS3, FAD104, TNFRSF6, ARG2, Gene_MMP9, FCGR1A, TGFB1, NCR, CRTAP, MAP2K6, ANXA3, CSF1R, HLA-DRA, JAK2;
FAD104, OSM, LDLR, TNFSF10, GADD45B, HLA-DRA, TNFRSF6, GADD45A, CD86, TDRD9, ITGAM, ANXA3, IFNGR1, MAPK14, CSF1R, TGFB1;

PSTPIP2, ARG2, MAP2K6, INSL3, SOCS3, JAK2, FAD104, ANKRD22, HLA-DRA, ITGAM, GADD45B, LY96, IRAK2, PFKFB3, TNFRSF6, IFNGR1;

CSF1R, CCL5, ARG2, BCL2A1, FCGR1A, MKNK1, TDRD9, IFNGR1, PFKFB3, ITGAM, JAK2, OSM, GADD45B, FAD104, NCR1, HLA-DRA;

CEACAM1, IL18R1, SOCS3, CRTAP, LDLR, HLA-DRA, LY96, IL1RN, IL10alpha, BCL2A1, GADD45A, TIFA, FAD104, ANKRD22, OSM, CCL5, IFNGR1;

FAD104, GADD45B, HLA-DRA, VNN1, IL10alpha, CD86, JAK2, INSL3, TDRD9, TLR4, IRAK4, SOD2, LDLR, CCL5, MKNK1, ARG2, IL18R1;

IRAK2, HLA-DRA, IFNGR1, MAP2K6, TLR4, ITGAM, SOCS3, CD86, ARG2, VNN1, IL18R1, ANXA3, FCGR1A, IL1RN, Gene_MMP9, TGFB1, IL10alpha;

IRAK2, MKNK1, PSTPIP2, ANXA3, HLA-DRA, TNFSF10, IFNGR1, PFKFB3, OSM, PRV1, IL1RN, IL10alpha, FAD104, CD86, TIFA, BCL2A1, TNFSF13B;

VNN1, IFNGR1, LY96, SOD2, IL18R1, SOCS3, FCGR1A, ARG2, CSF1R, Gene_MMP9, IRAK4, MAP2K6, TIFA, FAD104, HLA-DRA, GADD45B, IL1RN;

TNFSF13B, FAD104, PRV1, TIFA, SOD2, TDRD9, TLR4, TNFRSF6, MKNK1, OSM, MAP2K6, CCL5, ARG2, LDLR, HLA-DRA, PSTPIP2, IL18R1;

IRAK2, OSM, MAP2K6, TNFSF13B, ANKRD22, HLA-DRA, SOD2, TNFSF10, VNN1, ARG2, IRAK4, LY96, IFNGR1, JAK2, BCL2A1, FCGR1A, CSF1R;

HLA-DRA, GADD45A, ANXA3, ARG2, FAD104, PFKFB3, ITGAM, JAK2, MAPK14, OSM, CD86, LDLR, TIFA, CCL5, NCR1, IRAK2, SOD2, PRV1;

GADD45A, INSL3, IRAK2, TNFSF10, TGFB1, IRAK4, NCR, HLA-DRA, CEACAM1, GADD45B, MAPK14, CD86, IL18R1, CRTAP, ANKRD22, PSTPIP2, LY96, PFKFB3;

BCL2A1, ANKRD22, OSM, CD86, ITGAM, ANXA3, FCGR1A, CCL5, TIFA, IRAK4, HLA-DRA, NCR, CRTAP, TLR4, CEACAM1, FAD104, ARG2, MAP2K6;

INSL3, TLR4, BCL2A1, ANKRD22, FAD104, MAP2K6, GADD45B, ARG2, NCR, MKNK1, ITGAM, CSF1R, IL1RN, HLA-DRA, LDLR, CRTAP, PRV1, LY96;

CRTAP, HLA-DRA, ARG2, PSTPIP2, MKNK1, INSL3, TIFA, CEACAM1, JAK2, Gene_MMP9, TLR4, IRAK4, CD86, FAD104, CCL5, TNFSF10, LDLR, IFNGR1;

MAP2K6, CSF1R, HLA-DRA, ANKRD22, MKNK1, SOCS3, TNFSF10, LDLR, FAD104, CEACAM1, TNFSF13B, TDRD9, IRAK4, VNN1, IL18R1, OSM, PSTPIP2, Gene_MMP9;

CCL5, SOD2, JAK2, IRAK4, IRAK2, Gene_MMP9, IFNGR1, TLR4, GADD45A, TNFSF10, CSF1R, IL18R1, PRV1, TNFSF13B, HLA-DRA, LDLR, CD86, SOCS3, FAD104;

MAP2K6, TNFSF13B, SOD2, GADD45B, HLA-DRA, CSF1R, CCL5, TIFA, NCR, IFNGR1, OSM, CD86, SOCS3, ARG2, IL10alpha, BCL2A1, TDRD9, LDLR, GADD45A;

ARG2, PRV1, IRAK4, TNFRSF6, MAP2K6, SOCS3, IL18R1, HLA-DRA, IFNGR1, ANXA3, TNFSF10, JAK2, FCGR1A, GADD45A, INSL3, IL1RN, TNFSF13B, ITGAM, CSF1R;

LDLR, INSL3, JAK2, TNFRSF6, PRV1, IFNGR1, OSM, ITGAM, FCGR1A, IL10alpha, NCR, TDRD9, MAP2K6, TNFSF13B, TIFA, HLA-DRA, ANKRD22, GADD45B, IL1RN;

SOD2, ARG2, HLA-DRA, LY96, Gene_MMP9, VNN1, CD86, IL10alpha, CSF1R, PSTPIP2, JAK2, TNFSF13B, IRAK2, CCL5, ANKRD22, TLR4, IL1RN, OSM, GADD45B;

SOCS3, TGFB1, FCGR1A, TDRD9, GADD45A, TIFA, IFNGR1, VNN1, ITGAM, MAPK14, OSM, ANXA3, TNFSF13B, IL1RN, HLA-DRA, ARG2, MAP2K6, TLR4, PSTPIP2;

CD86, INSL3, MAPK14, TIFA, MAP2K6, Gene_MMP9, CRTAP, CSF1R, MKNK1, IL10alpha, FAD104, PRV1, BCL2A1, NCR, LDLR, IRAK4, HLA-DRA, IFNGR1, TDRD9;

IL1RN, TLR4, PSTPIP2, IL18R1, GADD45A, IL10alpha, BCL2A1, MKNK1, IRAK2, HLA-DRA, ANKRD22, NCR, CEACAM1, IRAK4, OSM, TIFA, SOD2, TGFB1, Gene_MMP9;

GADD45A, LY96, ITGAM, CCL5, TNFSF10, TNFSF13B, HLA-DRA, CSF1R, TIFA, SOCS3, MKNK1, ARG2, IFNGR1, IL1RN, BCL2A1, OSM, PFKFB3, PSTPIP2, IRAK2;

Gene_MMP9, GADD45A, PSTPIP2, INSL3, IRAK4, HLA-DRA, CCL5, TGFB1, OSM, LY96, TDRD9, NCR, PFKFB3, IFNGR1, IRAK2, VNN1, CRTAP, TIFA, CD86;

LDLR, ARG2, MAP2K6, MAPK14, IL18R1, CCL5, PSTPIP2, ANKRD22, OSM, TDRD9, HLA-DRA, SOCS3, ANXA3, TNFRSF6, TIFA, CD86, FAD104, MKNK1, BCL2A1, IRAK2;

FCGR1A, HLA-DRA, ARG2, CRTAP, CEACAM1, TNFSF13B, OSM, ANXA3, IL1RN, Gene_MMP9, TNFRSF6, FAD104, JAK2, IFNGR1, MKNK1, LDLR, IL10alpha, TGFB1, SOD2, CCL5;

GADD45A, MAPK14, ARG2, TDRD9, NCR1, IL18R1, SOD2, ITGAM, FCGR1A, SOCS3, HLA-DRA, IRAK4, TNFRSF6, PRV1, CD86, TGFB1, TNFSF13B, TIFA, VNN1, FAD104;

HLA-DRA, ARG2, IL1RN, SOCS3, PSTPIP2, CCL5, IFNGR1, CD86, TLR4, TGFB1, LY96, TNFRSF6, OSM, MAP2K6, VNN1, ITGAM, TNFSF10, NCR1, IRAK4, MAPK14;

GADD45B, SOD2, CRTAP, OSM, TNFSF13B, CCL5, CD86, INSL3, HLA-DRA, TNFRSF6, TGFB1, GADD45A, FCGR1A, FAD104, JAK2, IL1RN, PFKFB3, MAP2K6, CEACAM1, TDRD9;

TLR4, GADD45A, JAK2, OSM, CD86, SOCS3, CEACAM1, IL18R1, MAP2K6, PRV1, FAD104, BCL2A1, VNN1, INSL3, PSTPIP2, ANKRD22, TNFSF10, IFNGR1, CRTAP, HLA-DRA;

FAD104, IL18R1, TIFA, TNFRSF6, Gene_MMP9, ARG2, OSM, TNFSF13B, FCGR1A, CD86, CEACAM1, LY96, NCR1, TNFSF10, PFKFB3, PRV1, GADD45A, SOCS3, HLA-DRA, IRAK2;

TDRD9, MKNK1, PFKFB3, IRAK2, INSL3, ITGAM, MAPK14, JAK2, HLA-DRA, CSF1R, CRTAP, NCR1, SOD2, TIFA, IRAK4, CD86, OSM, BCL2A1, LY96, ANKRD22;

ANKRD22, CRTAP, NCR1, OSM, INSL3, CD86, CCL5, JAK2, CSF1R, GADD45B, ANXA3, SOCS3, PSTPIP2, FCGR1A, HLA-DRA, IRAK2, IL1RN, IL18R1, PFKFB3, Gene_MMP9;

IL1RN, LY96, ARG2, PRV1, GADD45A, TNFSF10, FCGR1A, IL10alpha, LDLR, PFKFB3, CRTAP, SOD2, CEACAM1, IL18R1, CCL5, PSTPIP2, TLR4, VNN1, HLA-DRA, JAK2, ANKRD22;

SOCS3, ITGAM, Gene_MMP9, MKNK1, ARG2, CRTAP, BCL2A1, PRV1, NCR1, HLA-DRA, MAP2K6, FCGR1A, CD86, FAD104, CCL5, TGFB1, TDRD9, OSM, GADD45B, IRAK4, LY96;

INSL3, BCL2A1, PSTPIP2, OSM, MAP2K6, CCL5, MKNK1, FAD104, ITGAM, MAPK14, IL1RN, VNN1, IRAK2, FCGR1A, CD86, PFKFB3, TDRD9, HLA-DRA, ARG2, TLR4, CEACAM1;

TIFA, MKNK1, TNFSF13B, CSF1R, HLA-DRA, IL18R1, MAPK14, INSL3, PFKFB3, ANKRD22, LDLR, ARG2, CCL5, LY96, PSTPIP2, GADD45A, CEACAM1, JAK2, TGFB1, VNN1, IL1RN;

GADD45A, CCL5, LDLR, ARG2, IRAK2, SOCS3, SOD2, PRV1, MAP2K6, INSL3, TNFSF10, IL18R1, IL1RN, MAPK14, FAD104, IFNGR1, HLA-DRA, PSTPIP2, ITGAM, CSF1R, IL10alpha;

CD86, TGFB1, ITGAM, IL10alpha, JAK2, TIFA, FAD104, CRTAP, IL1RN, BCL2A1, CCL5, GADD45B, HLA-DRA, SOD2, OSM, NCR, VNN1, IL18R1, ANXA3, Gene_MMP9, PSTPIP2;

MAPK14, SOD2, PRV1, GADD45B, MKNK1, IL18R1, INSL3, NCR1, LY96, IRAK2, CSF1R, TNFRSF6, HLA-DRA, VNN1, IRAK4, FAD 104, CEACAM 1, IFNGR1, FCGR1A, TIFA, CD86;

HLA-DRA, PRV1, GADD45A, IL1RN, IL18R1, TNFRSF6, LDLR, IRAK4, BCL2A1, TIFA, PSTPIP2, SOCS3, IL10alpha, FAD104, MKNK1, TNFSF13B, JAK2, TDRD9, TNFSF10, FCGR1A, CD86;

INSL3, GADD45A, TGFB1, JAK2, IRAK2, OSM, TIFA, TNFSF13B, HLA-DRA, FCGR1A, BCL2A1, PRV1, CEACAM1, SOCS3, MAPK14, IRAK4, ANXA3, TNFRSF6, FAD104, IFNGR1, Gene_MMP9;

BCL2A1, ANKRD22, IL10alpha, HLA-DRA, VNN1, GADD45B, TNFRSF6, CSF1R, IRAK4, ITGAM, IL1RN, IRAK2, LY96, MAPK14, JAK2, Gene_MMP9, TLR4, ARG2, CCL5, SOCS3, MAP2K6;

TDRD9, VNN1, GADD45A, ANKRD22, PFKFB3, TNFSF13B, SOCS3, IL18R1, IL1RN, ARG2, CSF1R, HLA-DRA, PRV1, CEACAM1, CD86, IFNGR1, CCL5, MAP2K6, TGFB1, IL10alpha, Gene_MMP9;

ANXA3, TNFRSF6, TDRD9, IRAK2, MAP2K6, INSL3, FCGR1A, GADD45A, NCR, ARG2, VNN1, PRV1, MAPK14, IRAK4, SOCS3, ITGAM, HLA-DRA, CD86, CEACAM1, LY96, GADD45B;

IL18R1, GADD45A, BCL2A1, HLA-DRA, PSTPIP2, ANKRD22, CRTAP, FAD104, CD86, TNFRSF6, Gene_MMP9, IRAK2, SOD2, IL10alpha, IFNGR1, FCGR1A, TIFA, OSM, CCL5, GADD45B, TGFB1, TLR4;

TNFSF13B, LDLR, GADD45B, MAPK14, PFKFB3, CRTAP, MAP2K6, NCR, CCL5, ARG2, SOD2, BCL2A1, MKNK1, TIFA, ANKRD22, Gene_MMP9, TGFB1, IL1RN, HLA-DRA, IL18R1, VNN1, CSF1R;

TDRD9, CRTAP, ANKRD22, TNFSF13B, ANXA3, CCL5, FCGR1A, TNFSF10, TNFRSF6, PRV1, IRAK2, CEACAM1, SOCS3, CSF1R, FAD104, PSTPIP2, VNN1, ARG2, IL1RN, HLA-DRA, BCL2A1, INSL3;

GADD45B, HLA-DRA, NCR, TGFB1, OSM, MKNK1, TLR4, ARG2, CCL5, LDLR, IFNGR1, SOCS3, INSL3, TIFA, TNFSF10, CD86, IL10alpha, GADD45A, CSF1R, TDRD9, BCL2A1, ANXA3;

INSL3, PSTPIP2, MKNK1, FCGR1A, PFKFB3, OSM, TGFB1, MAPK14, IRAK2, GADD45A, ANKRD22, CCL5, HLA-DRA, IL10alpha, SOCS3, CD86, IFNGR1, ARG2, Gene_MMP9, GADD45B, VNN1, IL1RN;

ARG2, GADD45B, TNFSF10, IRAK2, MAPK14, IL1RN, MKNK1, CRTAP, TNFSF13B, PRV1, SOD2, VNN1, IL18R1, HLA-DRA, MAP2K6, INSL3, CEACAM1, IL10alpha, LY96, SOCS3, FCGR1A, ANKRD22;

IFNGR1, LDLR, ITGAM, VNN1, IL18R1, TGFB1, SOCS3, ANKRD22, HLA-DRA, TIFA, OSM, TLR4, IRAK4, INSL3, SOD2, TNFSF13B, LY96, IRAK2, BCL2A1, MAPK14, CCL5, MKNK1;

Gene_MMP9, BCL2A1, TDRD9, OSM, MAPK14, IRAK2, CRTAP, MAP2K6, TGFB1, IL18R1, TNFSF10, ANXA3, IFNGR1, GADD45A, TIFA, PSTPIP2, SOCS3, ITGAM, ARG2, HLA-DRA, FAD104, IRAK4;

IRAK2, IL1RN, ITGAM, LY96, IFNGR1, TGFB1, TIFA, PFKFB3, Gene_MMP9, FAD104, TNFSF13B, VNN1, LDLR, INSL3, HLA-DRA, NCR1, TDRD9, TNFRSF6, ANXA3, CSF1R, SOCS3, IL18R1;

TNFRSF6, INSL3, LDLR, CD86, TGFB1, NCR1, Gene_MMP9, CRTAP, HLA-DRA, BCL2A1, MKNK1, IL18R1, TLR4, CEACAM1, PRV1, CCL5, OSM, TDRD9, PFKFB3, IFNGR1, IRAK2, PSTPIP2;

PFKFB3, ITGAM, ANKRD22, MAPK14, TGFB1, PSTPIP2, BCL2A1, IFNGR1, MKNK1, NCR, ARG2, HLA-DRA, INSL3, CRTAP, FCGR1A, LDLR, CCL5, JAK2, IRAK4, TLR4, LY96, IL10alpha;

TIFA, IFNGR1, HLA-DRA, Gene_MMP9, PRV1, FAD104, IL10alpha, GADD45B, IRAK4, IL1RN, TDRD9, IL18R1, BCL2A1, CD86, GADD45A, CCL5, ANXA3, OSM, SOCS3, PFKFB3, LDLR, CSF1R;

GADD45A, CSF1R, IL18R1, TGFB1, TNFSF13B, ANXA3, OSM, SOCS3, LY96, TDRD9, ITGAM, FCGR1A, IFNGR1, FAD104, HLA-DRA, PSTPIP2, MKNK1, CRTAP, GADD45B, Gene_MMP9, LDLR, TLR4, VNN1;

MAP2K6, TGFB1, HLA-DRA, IL10alpha, VNN1, GADD45B, CEACAM1, PRV1, OSM, IRAK4, IRAK2, ITGAM, CSF1R, TDRD9, NCR, TNFSF13B, CRTAP, BCL2A1, TIFA, IFNGR1, GADD45A, IL18R1, SOD2;

HLA-DRA, PFKFB3, IRAK4, MKNK1, TGFB1, CRTAP, ANXA3, CEACAM1, CCL5, JAK2, TNFSF10, IL1RN, CSF1R, IFNGR1, ARG2, LY96, Gene_MMP9, PRV1, CD86, IRAK2, ITGAM, IL10alpha, OSM;

FAD104, LY96, NCR1, TLR4, TNFSF13B, MAPK14, MAP2K6, HLA-DRA, FCGR1A, CD86, ANKRD22, LDLR, IL1RN, IFNGR1, TDRD9, TGFB1, GADD45A, PRV1, PFKFB3, ITGAM, JAK2, PSTPIP2, CRTAP;

CRTAP, OSM, TNFRSF6, IRAK2, VNN1, IRAK4, ANXA3, SOD2, ANKRD22, ITGAM, TLR4, MKNK1, IL18R1, CEACAM1, TGFB1, PRV1, Gene_MMP9, TNFSF13B, BCL2A1, HLA-DRA, INSL3, NCR1, CSF1R;

ARG2, MAPK14, IRAK4, LDLR, IL10alpha, Gene_MMP9, NCR1, OSM, CEACAM1, SOD2, CSF1R,

- CCL5, GADD45A, ITGAM, BCL2A1, HLA-DRA, PFKFB3, TNFSF13B, TNFSF10, IRAK2, VNN1, JAK2, PRV1;
- VNN1, SOCS3, ANKRD22, FAD104, IL18R1, OSM, ITGAM, CCL5, TGFB1, MAPK14, MKNK1, HLA-DRA, LDLR, PSTPIP2, ARG2, CSF1R, IL10alpha, MAP2K6, LY96, FCGR1A, TNFSF10, JAK2, TLR4;
- CEACAM1, MAP2K6, IL18R1, TIFA, HLA-DRA, FAD104, TGFB1, LDLR, ANKRD22, IL1RN, SOCS3, TNFSF13B, NCR1, CD86, BCL2A1, IL10alpha, TLR4, CRTAP, MKNK1, ITGAM, JAK2, OSM, ARG2;
- CCL5, IL1RN, TIFA, PRV1, TNFSF13B, INSL3, IRAK2, MKNK1, MAPK14, FCGR1A, SOCS3, JAK2, FAD104, IFNGR1, CRTAP, IL18R1, GADD45B, SOD2, TNFSF10, HLA-DRA, TNFRSF6, ANKRD22, LDLR;
- TNFRSF6, TNFSF10, CD86, IL10alpha, ARG2, TLR4, JAK2, MAP2K6, GADD45B, LDLR, TIFA, IRAK2, BCL2A1, SOD2, LY96, PFKFB3, HLA-DRA, CSF1R, FAD104, CRTAP, FCGR1A, ANXA3, SOCS3;
- NCR1, IL1RN, PRV1, IL18R1, HLA-DRA, BCL2A1, GADD45A, FAD104, TLR4, OSM, FCGR1A, TNFSF10, CRTAP, INSL3, GADD45B, LY96, IRAK2, CD86, VNN1, CCL5, JAK2, IL10alpha, MKNK1, IRAK4;
- GADD45A, MKNK1, ANXA3, TLR4, MAP2K6, TIFA, FCGR1A, IRAK2, TDRD9, VNN1, CSF1R, GADD45B, LDLR, IL1RN, ANKRD22, JAK2, HLA-DRA, IL10alpha, PSTPIP2, Gene_MMP9, CRTAP, IL18R1, MAPK14, ARG2;
- ARG2, JAK2, CSF1R, NCR, LY96, HLA-DRA, ANXA3, PSTPIP2, IRAK4, BCL2A1, IL1RN, IFNGR1, FCGR1A, VNN1, TNFSF10, MAPK14, TGFB1, GADD45B, INSL3, IRAK2, OSM, CD86, CRTAP, TNFSF13B;
- HLA-DRA, INSL3, PRV1, MAP2K6, TIFA, NCR, CSF1R, TDRD9, IL18R1, MKNK1, TNFRSF6, TNFSF10, LDLR, IRAK4, FAD104, ITGAM, PSTPIP2, MAPK14, TNFSF13B, GADD45B, CEACAM1, IL1RN, ANXA3, PFKFB3;
- VNN1, LDLR, FAD104, HLA-DRA, ARG2, IFNGR1, IRAK4, TNFRSF6, TIFA, MAP2K6, NCR1, OSM, PRV1, CSF1R, INSL3, TNFSF13B, JAK2, MAPK14, BCL2A1, IRAK2, TLR4, PSTPIP2, TDRD9, ANXA3;
- CD86, TNFSF13B, PSTPIP2, IL10alpha, HLA-DRA, MAP2K6, FCGR1A, Gene MMP9, JAK2, SOCS3, CSF1R, TDRD9, ARG2, NCR1, OSM, FAD104, BCL2A1, TNFRSF6, INSL3, VNN1, ITGAM, PRV1, TLR4, CEACAM1;
- TNFSF10, ITGAM, MAP2K6, TIFA, CSF1R, TDRD9, FAD104, TLR4, GADD45B, HLA-DRA, IRAK2, IRAK4, OSM, FCGR1A, CCL5, SOD2, VNN1, MKNK1, ARG2, Gene_MMP9, TGFB1, TNFSF13B, MAPK14, PFKFB3;
- TNFSF10, CEACAM1, IFNGR1, TIFA, MKNK1, ANXA3, IL1RN, IL10alpha, IL18R1, HLA-DRA, SOCS3, Gene MMP9, MAPK14, TGFB1, JAK2, IRAK2, TLR4, CSF1R, BCL2A1, PSTPIP2, MAP2K6, CD86, ITGAM, SOD2;
- SOD2, PFKFB3, MAP2K6, HLA-DRA, ANKRD22, IL18R1, Gene MMP9, LDLR, ARG2, GADD45A, JAK2, MKNK1, PRV1, FCGR1A, ITGAM, OSM, NCR1, VNN1, LY96, IFNGR1, TIFA, PSTPIP2, IL1RN, TLR4;
- GADD45A, SOCS3, SOD2, TGFB1, HLA-DRA, VNN1, CD86, CCL5, BCL2A1, CRTAP, MAP2K6, PRV1, IL18R1, CSF1R, OSM, IRAK2, PSTPIP2, TLR4, FCGR1A, ANKRD22, CEACAM1, JAK2, INSL3, TDRD9, TNFSF10;
- SOCS3, VNN1, FCGR1A, SOD2, OSM, TNFSF10, LY96, Gene MMP9, GADD45B, CRTAP, PRV1, HLA-DRA, GADD45A, TLR4, ARG2, IRAK2, FAD104, INSL3, PSTPIP2, TIFA, TGFB1, IL18R1, MAP2K6, LDLR, ANXA3;
- PSTPIP2, CEACAM1, FAD104, TIFA, ANKRD22, OSM, TNFSF13B, IRAK4, INSL3, GADD45A, IL10alpha, CSF1R, HLA-DRA, SOCS3, GADD45B, CCL5, Gene_MMP9, LY96, TLR4, IFNGR1, TGFB1, BCL2A1, MAP2K6, CD86, PFKFB3;
- IFNGR1, VNN1, ANKRD22, FCGR1A, JAK2, MAP2K6, SOD2, TNFSF13B, IRAK4, CEACAM1, LY96, MAPK14, INSL3, NCR1, Gene MMP9, CCL5, HLA-DRA, LDLR, TNFRSF6, PFKFB3, ANXA3, SOCS3, ARG2, ITGAM, CSF1R;
- LDLR, GADD45A, IFNGR1, ARG2, MAPK14, HLA-DRA, CRTAP, OSM, TDRD9, CSF1R, FCGR1A, Gene MMP9, NCR, PRV1, IRAK4, TGFB1, TLR4, LY96, IL1RN, FAD104, SOD2, CCL5, TNFRSF6, MAP2K6, TNFSF13B; and
- PSTPIP2, NCR1, MKNK1, SOCS3, IL1RN, IFNGR1, IL18R1, CSF1R, ITGAM, LDLR, TIFA, CRTAP, OSM, TLR4, CEACAM1, Gene_MMP9, INSL3, MAP2K6, CCL5, FAD104, HLA-DRA, PRV1, VNN1, PFKFB3, JAK2.
- 116.** The method of claim **114**, wherein said biomarker mRNAs comprise a combination of biomarker mRNAs selected from the combinations consisting of:
- MKNK1, CD86, OSM, TIFA, HLA-DRA, SOCS3;
- FAD104, ARG2, FCGR1A, SOCS3, HLA-DRA, ANXA3;
- CD86, IRAK2, ARG2, PFKFB3, MAPK14, PRV1, VNN1, HLA-DRA, FAD104;
- IL10alpha, HLA-DRA, TGFB1, FCGR1A, CSF1R, IRAK2, GADD45A, PFKFB3, SOCS3;
- ARG2, IRAK4, GADD45A, VNN1, IL18R1, JAK2, ANXA3, CSF1R, HLA-DRA, PFKFB3;
- TNFRSF6, OSM, PRV1, INSL3, TLR4, MKNK1, IRAK4, HLA-DRA, VNN1, IL10alpha, FCGR1A; and
- NCR1, CEACAM1, IRAK4, ARG2, TNFSF13B, PFKFB3, OSM, TNFRSF6, SOCS3, HLA-DRA, TNFSF10, JAK2, SOD2.
- 117.** The method of claim **114**, wherein said biomarker mRNAs comprise a combination of biomarker mRNAs selected from the combinations consisting of:
- OSM, Gene MMP9, TLR4, TDRD9, CCL5, CRTAP, HLA-DRA;
- IFNGR1, CEACAM1, JAK2, SOD2, HLA-DRA, MAPK14, PRV1, VNN1; and

CCL5, IL10alpha, GADD45B, LDLR, PSTPIP2, CD86, HLA-DRA, TLR4.

118. The method of claim **114**, wherein said first blood sample is a whole blood sample or a plasma sample.

119. The method of claim **114**, wherein the abundances of said biomarker mRNAs are expressed in relative fluorescence intensity units.

120. The method of claim **114**, wherein the measuring step comprises performing reverse-transcription-polymerase chain reaction to make cDNA complimentary to said biomarker RNAs.

121. The method of claim **114**, wherein the measuring step comprises contacting said biomarker mRNAs, or cDNAs thereof, to a nucleic acid array.

122. The method of claim **114**, wherein the comparing step comprises applying a decision rule to predict the increased or decreased likelihood of sepsis in the SIRS patient.

123. The method of claim **120**, wherein the comparing step is performed on a computer.

* * * * *