

AUSTRALIA

Patents Act 1952

DECLARATION IN SUPPORT OF A CONVENTION OR NON-CONVENTION APPLICATION FOR A PATENT OR PATENT OF ADDITION

Name(s) of Applicant(s)

In support of the application made by CALYPTE BIOMEDICAL COMPANY

Title

for a patent for an invention entitled SELF-CONTAINED MULTI-IMMUNOASSAY DIAGNOSTIC SYSTEM

Name(s) and address(es) of person(s) making declaration

Howard B. Urnovitz, Chairman and Chief Scientific Officer of
I/We, CALYPTE BIOMEDICAL COMPANY
1440 Fourth Street
Berkeley, California 94710, U.S.A.

do solemnly and sincerely declare as follows:-

- 1. I am/we are the applicant(s) for the patent, or am/are authorised by the abovementioned applicant to make this declaration on its behalf.
- 2. The basic application(s) as defined by Section 141 of the Act was/were made in the following country or countries on the following date(s) by the following applicant(s) namely:-

Country, filing date and name of Applicant(s) for the or each basic application

in United States on August 5, 19 87
by Howard B. Urnovitz
in _____ on _____ 19____
by _____

- 3. The said basic application(s) was/were the first application(s) made in a Convention country in respect of the invention the subject of the application.

Name(s) and address(es) of the or each actual inventor

- 4. The actual inventor(s) of the said invention is/are Howard B. Urnovitz, 783 22nd Avenue, San Francisco, California 94121

See reverse side of this form for guidance in completing this part

- 5. The facts upon which the applicant(s) is/are entitled to make this application are as follows:-
"the applicant is the assignee of the actual inventors"

DECLARED at Berkeley, CA, U.S.A. this 16 day of June 16 19 89

CALYPTE BIOMEDICAL COMPANY

By: 
Howard B. Urnovitz
Chairman and Chief Scientific Officer

This form may be completed and filed after the filing of a patent application but the form must not be signed until after it has been completely filled in as indicated by the marginal notes. The place and date of signing must be filled in. Company stamps or seals should not be used.

Information for completing paragraph 5 -

- A. If the application is by the actual inventor(s) it is not necessary to make any insertion in paragraph 5.
- B. If the application is by a company or person to whom the invention has been assigned the appropriate insertion is "the applicant is the assignee of the actual inventor(s)"
- C. If the application is by an employer entitled to the invention by service agreement(s) and a specific assignment has not been made the appropriate insertion is "the applicant would be entitled to have assigned to it (him, her) a patent granted to the actual inventor (any of the actual inventors) in respect of the said invention."
- D. Where Convention priority is claimed and the applicant in Australia is not the applicant in the Convention country, paragraph 5 must indicate how the Australian applicant obtained the right to claim priority. For this purpose appropriate additional wording may be "(and) the applicant is the assignee of the applicant(s) named in paragraph 2 above" or "(and) the applicant has the consent of the applicant(s) named in paragraph 2 above"
- E. If the above information appears insufficient or inappropriate please defer completing the declaration form and discuss the matter with us. Remember that a declaration form may be completed and filed after lodgement of a patent application without any penalty or disadvantage. We do not need any signed form before filing an application.

(12) PATENT ABRIDGMENT (11) Document No. AU-B-23067/88
(19) AUSTRALIAN PATENT OFFICE (10) Acceptance No. 628293

- (54) Title
SELF-CONTAINED MULTI-IMMUNOASSAY DIAGNOSTIC SYSTEM
- International Patent Classification(s)
(51)⁴ **G01N 033/53 G01N 033/58 G01N 033/543 G01N 033/544**
G01N 033/545 G01N 033/552
(51)⁵ **G01N 033/566 G01N 033/571 G01N 033/576**
- (21) Application No. : **23067/88** (22) Application Date : **05.08.88**
- (87) PCT Publication Number : **WO89/01158**
- (30) Priority Data
- (31) Number (32) Date (33) Country
081874 05.08.87 US UNITED STATES OF AMERICA
- (43) Publication Date : **01.03.89**
- (44) Publication Date of Accepted Application : **17.09.92**
- (71) Applicant(s)
CALYPTE BIOMEDICAL COMPANY
- (72) Inventor(s)
HOWARD B. URNOVITZ
- (74) Attorney or Agent
PHILLIPS ORMONDE & FITZPATRICK , 367 Collins Street, MELBOURNE VIC 3000
- (57) Claim

1. A test strip for detecting a target analyte comprising an antibody based analyte or antigenic substance in a sample from a human subject which comprises

- (a) a solid support;
- (b) a reagent directed against the target analyte bound to a first discrete area on the solid support wherein when said target analyte is an antigenic substance said reagent is an antibody-based reagent and wherein when said target analyte is an antibody said reagent is an antigenic substance which binds said antibody;
- (c) an antihuman antibody which binds to an antigen which naturally occurs in human subjects said anti-human antibody being bound to a second discrete area on the solid support as a positive control;
- (d) an antibody directed against an antigen which

does not naturally occur in human subjects and which is different from said analyte bound to a thir discrete area on the solid support as a negative control.

12. A method for detecting in a sample from a human subject the presence of a target antigenic substance which comprises:

- (a) pretreating the sample to be tested so as to prevent non-specific and specific binding of substances present in the sample to proteins, including antibodies and recombinant antigens present on the test strip, and thus prevent spurious results;
- (b) contacting the resulting pretreated sample with the test strip under conditions such that an antibody bound to the test strip and directed against the target antigenic substance forms a complex with the antigenic substance in the pretreated sample;
- (c) thereafter washing the test strip to remove target antigen that is not complexed with the antibody bound to the test strip;
- (d) contacting the resulting, treated test strip with labelled antibody to the target antigenic substance under conditions such that the labelled antibody forms a complex with the target antigenic substance complexed to the antibody bound to the test strip;
- (e) detecting the presence of labelled antibody complexed to the test strip, and thereby the presence of the target antigenic substance in the sample; and

(11) AU-B-23067/88
(10) 628293

-3-

- (f) verifying the correctness of the detection so made by determining that a positive control is labelled and a negative control is not labelled on the test strip.

13. A method for detecting in a sample from a human subject the presence of a target human antibody directed to an antigenic substance on which comprises:

- (a) adding to the sample to be tested a pretreatment material so as to prevent simultaneously non-specific and specific binding of nontarget substances present in the sample to a test strip, and thus preventing false positive results;
- (b) contacting the resulting pretreated sample with the test strip under conditions such that an antigenic substance bound to the test strip forms a complex with any target human antibody directed against it which is present in the sample;
- (c) thereafter washing the test strip to remove target human antibody that is not complexed with the antigenic substance bound to the test strip;
- (d) contacting the resulting, treated test strip with labelled antibody which binds to human immunoglobulins under conditions such that the antibody forms a complex with any target human antibody complexed to the antigenic substance bound to the test strip;
- (e) detecting the presence of labelled antibody which binds to human immunoglobulins complexed

(11) AU-B-23067/88
(10) 628293

-4-

to the test strip, and thereby the presence of target human antibody in the sample; and

- (f) verifying the correctness of the detection so made by determining that a positive control is labelled and a negative control is not labelled on the test strip.



INTERNATIONAL APPLICATION PUBLISHED UNDER THE PATENT COOPERATION TREATY (PCT)

| | | |
|---|-----------|---|
| <p>(51) International Patent Classification⁴ : G01N 33/543, 33/545, 33/552 G01N 33/53, C12Q 1/68</p> | <p>A1</p> | <p>(11) International Publication Number: WO 89/ 01158 (43) International Publication Date: 9 February 1989 (09.02.89)</p> |
| <p>(21) International Application Number: PCT/US88/02684 (22) International Filing Date: 5 August 1988 (05.08.88) (31) Priority Application Number: 081,874 (32) Priority Date: 5 August 1987 (05.08.87) (33) Priority Country: US (71) Applicant: CALYPTE BIOMEDICAL COMPANY [US/US]; 1440 Fourth Street, Berkeley, CA 94170 (US). (72) Inventor: URNOVITZ, Howard, B. ; 783 22nd Avenue, San Francisco, CA 94121 (US). (74) Agent: WHITE, John, P.; Cooper & Dunham, 30 Rockefeller Plaza, New York, NY 10112 (US).</p> <p style="font-size: 2em; font-weight: bold; text-align: center;">628293</p> | | <p>(81) Designated States: AT (European patent), AU, BE (European patent), CH (European patent), DE (European patent), DK, FI, FR (European patent), GB (European patent), IT (European patent), JP, KR, LU (European patent), NL (European patent), NO, SE (European patent).</p> <p>Published <i>With international search report. Before the expiration of the time limit for amending the claims and to be republished in the event of the receipt of amendments.</i></p> <p style="text-align: right; font-weight: bold;">A. O. J. P. 20 APR 1989</p> <div style="border: 1px solid black; padding: 5px; text-align: center; margin: 10px auto; width: fit-content;"> <p>AUSTRALIAN - 1 MAR 1989 PATENT OFFICE</p> </div> |

(54) Title: SELF-CONTAINED MULTI-IMMUNOASSAY DIAGNOSTIC SYSTEM

(57) Abstract

The present invention provides a test strip (10) for detecting, in a sample from a human subject, the presence of an antigenic substance which comprises a solid support (11), the antigenic substance bound to a first discrete area (14) on the solid support (11), an anti-human antibody bound to a second discrete area (15) on the solid support (11) as a positive control, and an antibody directed against an antigen which does not naturally occur in human subjects bound to a third discrete area (12) on the solid support (11) as a negative control. The invention additionally provides a test strip (21) for detecting, in a sample from a human subject, the presence of an antigenic substance which comprises a solid support (11), an antibody-based reagent directed against the antigenic substance in an immune complex and native human antibody thereto bound to a first discrete area (24) on the solid support (11), an anti-human antibody bound to a second discrete area (15) on the solid support (11) as a positive control, and an antibody directed against an antigen which does not naturally occur in human subjects bound to a third discrete area (12) on the solid support (11) as a negative control. The invention also provides for a method for detecting in a sample from a human subject the presence of an antigenic substance using the aforementioned test strips.

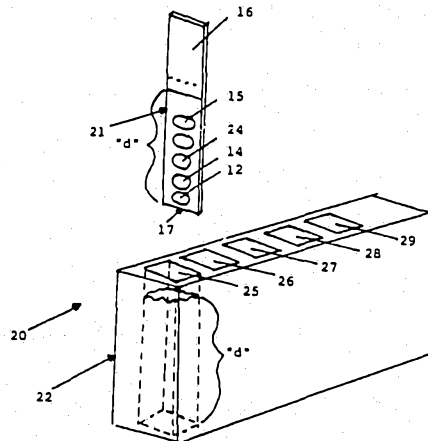

SELF-CONTAINED MULTI-IMMUNOASSAY DIAGNOSTIC SYSTEM

5

This application is a continuation-in-part of U.S. Serial No. 081,874, filed August 5, 1987, the contents of which are hereby incorporated by reference into the subject application.

10

Field of the Invention.

This invention is in the field of immunodiagnostics. More specifically, this invention provides test strips, as well as kits containing, and methods employing, these strips for use in the immunological detection of analytes in aqueous liquids, particularly biological samples such as blood, urine, and the like.

15

Background of the Invention

20

In recent years, the detection, or quantitative determination, or both, of analytes based upon reactions with immunological reagents has gained considerable importance, especially in the field of medical testing. Commonly, these methods involve contacting a sample suspected of containing the analyte with a material which exhibits specific immunologic reactivity with the analyte, for example, an antibody directed to an epitope present on the analyte. If the analyte is present in the sample, it specifically conjugates with the antibody to form a complex. A wide range of "developer" or "reporter" mechanisms have been proposed and are in use to indicate whether the conjugation reaction occurs. (See, for example, United States Patent Nos. 4,366,242, issued December 28, 1982 to

25

30

35

-2-

Neumann, et al; 4,278,653, issued July 14, 1981 to Harris, et al.; and 4,208,479, issued June 17, 1980 to Zuk, et al.)

5 Such methods have become increasingly popular since the introduction of monoclonal antibodies (MAbs), which may be produced using the technology developed by Kohler & Milstein, "Continuous Cultures of Fused Cells Secreting Antibody of Preferred Specificity," Nature, (1975) 256: 495-7, and which have unique specificity for the analytes with which they conjugate. (See, for example, 10 United States Patent No. 4,576,110, issued March 8, 1983 to David, et al.).

15 As these methods have evolved, there has been a parallel search for better ways to apply them on a day-to-day basis. This has led to a range of test devices, test kits, and the like. (See, for example, United States Patent Nos. 4,623,461, issued November 18, 1986 to Hossom, et al.; 3,888,629, issued June 10, 1975 to 20 Bagshawe; 4,458,020, issued July 3, 1984 to Bohn, et al.; 4,496,654, issued January 29, 1985 to Katz, et al.; and 4,305,924, issued December 15, 1981 to Piasik, et al.)

25 Desirable characteristics of a test kit or device include the following:

1. The test device or kit should be easy to store and to use.

30 2. It should give unambiguous results without false positives or false negatives.

3. It should allow a multiplicity of samples to be screened in a short period.

35 4. Ideally, it should provide the user with positive indication that it has been used properly as

-3-

confirmation that a false reading has not been obtained.

5. Preferably, it should allow a plurality of tests to be run simultaneously.

5 6. Preferably, the test can be configured to use whole blood or its fractionated components.

10 It is a primary object of the present invention to provide a test strip and a test kit based thereon which provides these desirable features.

15

20

25

30

35

Summary of the Invention

In accordance with the invention we provide a test strip for detecting a target analyte comprising an antibody based analyte or antigenic substance in a sample from a human subject which comprises

(a) a solid support;

(b) a reagent directed against the target analyte said reagent being bound to a first discrete area on the solid support wherein when said target analyte is an antigenic substance said reagent is an antibody or fragment thereof and wherein when said target analyte is an antibody said reagent is an antigenic substance which binds said antibody;

(c) an anti-human antibody which binds to an antigen which naturally occurs in human subjects said antihuman antibody being bound to a second discrete area on the solid support as a positive control;

(d) an antibody directed against an antigen which does not naturally occur in human subjects and which is different from said analyte bound to a third discrete area on the solid support as a negative control.

In one embodiment, the present invention provides a test strip for detecting, in a sample from a human subject, the presence of an antigenic substance by detecting the antibody formed in response to said antigen which test strip comprises a solid support, the antigenic substance bound to a first discrete area on the solid support, an anti-human antibody bound to a second discrete area on the solid support as a positive control. and an antibody directed against an antigen which does not naturally occur in human subjects bound to a third discrete area on the solid support as a negative control.

In another embodiment, the invention additionally provides a test strip for detecting, in a sample from a human subject, the presence of an antigenic substance which comprises a solid support, an antibody-based reagent directed against the



antigenic substance in an immune complex and native human antibody thereto bound to a first discrete area on the solid support, an anti-human antibody bound to a second discrete area on the solid support as a positive control, and an antibody directed against an antigen which does not naturally occur in human subjects bound to a third discrete area on the solid support as a negative control.

In a further embodiment the invention provides a test strip, for detecting in a sample from a human subject, the presence of a target human antibody and a target antigenic substance which comprises:

- a) a solid support;
- b) an antigenic substance which binds the target human antibody bound to a first discrete area on the solid support;
- c) an antibody or fragment thereof directed against the target antigenic substance bound to a second discrete area on the solid support;
- d) an antibody or fragment thereof which binds to a human antigen known to be present in the sample bound to a third discrete area on the solid support as a positive control;
- e) an antibody or fragment thereof directed against an antigen which does not naturally occur in human subjects and which is directed against an antigen different to said target antigenic substance bound to a fourth discrete area on the solid support as a negative control; and
- f) an antigen which does not naturally occur in human subjects and is directed to an antibody different to said target human antibody as a second negative control bound to a fifth discrete area on the solid support.

The invention also provides a method for detecting in a sample from a human subject the presence of an antigenic substance using the aforementioned test strips. As described above the antigenic substance may be detected directly in one embodiment and indirectly by detection of the antibody created in response to said antigen, in another embodiment.



Thus, the present invention provides a test strip for immunologically detecting the presence of one or more analytes in aqueous specimens. The strip device comprises a solid support which has a plurality of

5

10

15

20

25

30

35

39



5 discrete areas on its surface. At least one of these
areas is a test area which carries a monoclonal
antibody (or a combination selected from polyclonal
antibody, mono- or divalent antibody fragment, hybrid
antibody, heterobifunctional antibody, or genetically
10 manipulated or cloned antibody) to an analyte to be
detected or quantitatively determined. This antibody
or combination is preferably conjugated to, or
immobilized on, the surface of the support. At least
one of the discrete areas on the test strip carries a
15 positive control, i.e., a control material which
produces a positive signal only when the test area has
been contacted with the specimen. In preferred
embodiments this positive control is an immunological
control, such that the control event includes an
immunological reaction between a species always present
in the specimen and its immunologically specific
partner immobilized in the positive control zone.

20 In other preferred embodiments, this test strip
includes at least one area carrying a negative control,
that is, a control material which does not give rise to
a detectable event in the presence of a normal specimen
but does give rise to a detectable event when the
25 sample is abnormal.

In another embodiment, this test strip contains a
30 plurality of separate test areas containing different
antibodies or combinations of antibodies so as to
detect more than one analyte in the specimen.

In another embodiment, this test strip contains a
35 plurality of separate test areas containing different
analytes or combinations of analytes to detect antibody
or other analytes.

5 In yet another embodiment, this invention provides a test kit. This test kit includes the test strip just described and a test plate comprising a plurality of liquid holders, each shaped and sized to receive the test strip and to permit the test areas and positive control zone and negative control zone, if any, to simultaneously contact each of a sequence of liquids which are predeposited in the holders and at least one of which includes the test specimen.

10

15 In a presently preferred embodiment of this kit, the test plate comprises a plurality of liquid holders so as to permit a plurality of specimens to be tested at the same time, using a plurality of test strips.

20

25

30

35

Description of the Figures

5 Figure 1 is a perspective view of a test strip in accordance with the invention, showing its various zones or areas in semischematic form;

10 Figure 2 is a perspective and semischematic view of another embodiment of a test strip of this invention, together with a sample test plate;

Figure 3 is a perspective view of a test plate adapted to permit multiple specimens to be tested simultaneously; and

15 Figure 4 is a block diagram of a typical test protocol which may be employed according to the present invention.

20

25

30

35

Detailed Description of the Invention

5 This invention provides a test strip for detecting, in a sample from a subject, particularly a human subject, the presence of an antigenic substance. This test strip comprises a solid support, the antigenic substance bound to a first discrete area on the solid support, an anti-human antibody bound to a second discrete area on the solid support as a positive control, and an antibody directed against an antigen which does not naturally occur in human subjects bound to a third discrete area on the solid support as a negative control. Such a test strip may also be readily adapted so as to quantitatively determine the amount or concentration of the antigenic substance present in the sample.

10 This invention also provides a test strip which comprises all of the elements of the aforementioned test strip and additionally comprising an antibody-based reagent directed against the antigenic substance in an immune complex and native human antibody thereto, bound to a fourth discrete area on the solid support.

20 In one embodiment of this invention, the antigenic substance is a virus or a viral protein. For example, the antigenic substance may be HIV-1, HIV-1 GAG protein, HIV-1 ENV glycoprotein, HIV-1 POL protein, HTLV-1 GAG protein, HTLV-1 ENV glycoprotein, HTLV-1 POL protein, or an epitope thereof.

25 In test strips according to this invention, the solid support may comprise glass fiber filter paper, nitrocellulose, scintered glass, plastic, synthetic polymer, cellulose, cellulose acetate,

30

35

-9-

polytetrafluoroethylene, polyethylene, polypropylene, or polyvinylidene fluoride.

5 In certain embodiments of this invention involving an antibody-based reagent, this reagent comprises a monoclonal antibody, polyclonal antibody, mono- or divalent antibody fragment, hybrid antibody, heterofunctional antibody, or genetically manipulated or cloned antibody.

10 In a preferred embodiment of this invention the anti-human antibody on the test strip is a monoclonal antibody.

15 Similarly in a preferred embodiment of this invention, the antigen which does not naturally occur in human subjects and which is present on the test strip is a synthetic organic molecule, e.g., dinitrophenol.

20 In preferred embodiments of this invention one or more of the anti-human antibody, the antibody directed against an antigen which does not naturally occur, or the antibody-based reagent is labeled, for example, labeled with a radioactive isotope, fluorophore, chromophore, or an enzyme which catalyzes a chemical
25 reaction which produces a detectable product.

30 The invention also provides a test strip for detecting, in a sample from a human subject, the presence of an antigenic substance which comprises a solid support, an antibody-based reagent directed against the antigenic substance in an immune complex and native human antibody thereto bound to a first discrete area on the solid support, an anti-human antibody or other
35 appropriate anticellular structure bound to a second

-10-

discrete area on the solid support as a positive control, and an antibody directed against an antigen which does not naturally occur in human subjects bound to a third discrete area on the solid support as a negative control. As those skilled in the art will appreciate, such a test strip may be readily adapted so as to quantitatively determine the amount or concentration of the antigenic substance present in the sample.

The invention further provides a method for detecting in a sample from a human subject the presence of an antigenic substance which comprises pretreating the sample to be tested so as to prevent non-specific and specific binding of substances present in the sample to proteins, including antibodies and recombinant antigens, present on the test strip, and thus prevent spurious results; contacting the resulting pretreated sample to be tested with the aforementioned test strip under conditions such that the antigenic substance bound to the test strip forms a complex with any antibody directed against it which is present in the sample and in the case of test strips onto which both the antigenic substance and the antibody-based reagent are bound, so that antigenic substance present in the sample binds to antibody thereto present on the test strip; thereafter treating the test strip to remove uncomplexed antibody directed against the antigenic substance; contacting the resulting, treated test strip with labeled antihuman antibody under conditions such that the antihuman antibody forms a complex with any human antibody bound to the test strip; detecting the presence of labeled antihuman antibody bound to the test strip and thereby the presence of, or antibody to, the antigenic substance and thus detecting the presence

-11-

of the antigenic substance in the sample; and verifying the correctness of the detection so made by means of the positive and negative controls on the test strip.

5 The invention additionally provides a method of detecting in a sample from a human subject the presence of an antigenic substance which comprises pretreating the sample to be tested so as to prevent non-specific binding of substances present in the sample to
10 proteins, including antibodies, present on the test strip and specific binding of human antibodies to the antigenic substance, and thus prevent spurious results; contacting the resulting pretreated sample with the
15 aforementioned under conditions such that the antibody-based reagent bound to the test strip forms a complex with any antigenic substance which is present in the sample; contacting the resulting, treated test strip with labeled antibody directed to the antigenic substance under conditions such that the labeled
20 antibody forms a complex with any antigenic substance bound to the test strip; detecting the presence of labeled antibody directed to the antigenic substance bound to the test strip and thereby the presence of the antigenic substance in the sample; and verifying the correctness of the detection so made by means of the
25 positive and negative controls on the test strip.

30 In preferred embodiments of the invention the hereinabove described method involves as the antigenic substance, a virus or viral protein, and as the sample, blood, serum, urine, or the like.

35 The invention also provides the aforementioned methods wherein the verification comprises contacting the test strip with labeled antihuman antibody under conditions

-12-

such that the labeled antihuman antibody binds to human antibody bound to the test strip.

5 Thus, the present invention provides an improved test strip device. One embodiment of this device is shown as 10 in Figure 1. It includes a solid support 11 having a plurality of readable areas 12, 14 and 15. While support 11 is shown as a solid "dip stick" structure, it can be virtually any geometric shape, including cube, block, rod, cylinder, prism, polygon, 10 spiral, sphere, or segmented combinations thereof. It can also be a carrier device holding materials such as plastic, metal, paper, or the like. It can be made of a wide range of materials including plastic, such as 15 polystyrene or the like; metal; paper; glass fiber; filter paper; nitrocellulose; scintered glass; synthetic polymers; cellulose; cellulose acetate; polytetrafluoroethylene; polyethylene; polypropylene; polyvinylidene fluoride; or any other material including the materials which it comes in contact with 20 during the test. Commonly, the materials deposited on its surface are adsorbed, chemically coupled, or otherwise bound to the surface of the test strip as described hereinafter.

25 Readable areas 12, 14 and 15 are arrayed separately on support 11 so as to give a plurality of potential signals when the strip is processed in the analysis method. At least one of the readable areas includes 30 antibody which is immunoreactive with a test analyte in the test specimen. The readable areas may also include an analyte reactive with test antibody or test analyte. At least one of the readable areas includes a positive control which reacts with a test specimen to verify via 35 a detectable signal when the test strip properly

-13-

contacts a test specimen. Preferably, this positive control is an immunologic positive control which undergoes immunologic reaction with a nonanalyte species in the specimen.

5

The readable areas can also include a negative control, namely, a discrete area containing one or more reagents that do not produce a reading with the specimen if the specimen is properly handled but which do give a reaction and produce a signal if the specimen is defective or has been mishandled.

10

15

The relative position of the positive control area and the antibody-containing areas may be important. Test strip 10 is used as a "dip stick." In use, the technician or automated test device grips or "holds" the strip by top end 16 and dips it into the liquid specimen and other reagents, lower end 17 first. This means that area 12 will contact these liquids before area 15 does. It is desirable, therefore, that the positive control, which gives a positive reading only when the specimen and reagents have properly contacted it be positioned as the last to be contacted or uppermost area, e.g., 15 in Figure 1. Conversely, the negative control, if present, should be positioned as the first to be contacted or bottommost, e.g., 12 in Figure 1.

20

25

30

The positive control and the negative controls are preferably immunologic. That is, they preferably function by means of immunological reactions. Thus, for example, when the test specimens are human serum-based, a typical positive control could be a region designed to be treated with a common immunoglobulin always found in blood or its fractionated components.

35

-14-

5 The test reagent region (14 in Figure 1) is based on and includes at least one antibody specific for the analyte being tested for. A wide range of antibodies against a wide range of potentially important analytes have been described in the literature and may be used.

10 Turning to Figure 2, a variation on the test strip of Figure 1 is shown as 21. Strip 21 is shown as part of an overall analysis kit 20 which also includes a test plate 22. Strip 21 includes support 11 and readable areas 12, 14 and 15 as previously described and an additional readable area 24. Area 24 may be an additional control, an analyte, or an additional antibody-containing test region. Area 24 may contain a second antibody against the same antigen of area 14 so as to provide additional confirmation or sophistication to the test result or it may contain an antibody against a second antigen-analyte. These various reagents are generally immobilized in their various regions to prevent cross-contamination and the like, which will give ambiguous results. Antibody or most analytes are commonly immobilized on plastics, carbohydrate polymers, adsorbent fibers, polymer-coated metal beads, silica gel, paper, glass filters, or the like, by either direct adsorption (incubation for limited times or until the reagent solution is completely dry) or by chemical coupling to reactive groups on the solid phase. The optimal conditions are unique for each reagent.

30 In a typical application, the test strip 21 is employed in concert with a test plate such as 22. Test plate 22 has several characteristics. For one, it contains a plurality of liquid storage wells such as 25, 26, 27,

35

-15-

28 and 29. The exact number is selected to accommodate the various steps required to effect the desired assay sequence. For another, the size of each of the wells is set so as to permit the strip to be inserted. For another, the wells are deep enough to accommodate a depth of liquid "d" which is a depth adequate to completely cover all the readable areas 12, 14 and 15; or 12, 14, 24 and 15, present on the test strip.

In use, one or more of the wells of test plate 22 are charged with predetermined quantities of reagents and samples according to a predetermined protocol and then the test strip is inserted into the wells, again according to a predetermined protocol. This gives rise to a readable detection event which is read together with the results of the positive and negative controls. On the basis of these readings, one may determine whether a valid test has been conducted and whether the analyte is present in the specimen.

For example, in a typical protocol a test strip might be constructed with an antibody against a suspected pathogen in human blood. Positive control 15 would have an antibody against a common blood constituent, and negative control 12 would have an antibody against a material not commonly found in blood but of concern as a contaminant, or the like.

Well 25 is charged with a premeasured quantity of diluent, buffer or a like aqueous medium. A given quantity of patient blood or other source is added to the liquid of well 25 and mixed with it. The strip is inserted into the liquid in well 25 for a preset interval. This permits the test and control areas on strip 21 to contact the liquid and the diluted blood

-16-

constituents. This allows the immunological reactions to occur between the antibodies in these areas and any appropriate species in the blood.

5 The sample well 25 and any other well may contain various reagents to prevent undesired reactions and the like. These may include materials so as to alter the properties of the sample, or materials to react with or remove undesired cross-reactive materials in the
10 samples.

A current problem with most immunodiagnostic assays is the undesirable interaction of sample constituents with the coated solid phase (i.e. background). These types
15 of interaction often cause negative samples to be interpreted as false positives. Background may be minimized by partitioning the undesirable reactants (specific and nonspecific) onto a second solid phase (usually be preincubating the sample before exposure to
20 the test solid phase). In the case of antibody capture assays, the second solid phase would have bound to it antibody specific for an analyte not found in the sample or test (i.e., irrelevant specificity). This type of second solid phase would remove both specific
25 and nonspecific background constituents for antibodies, the solid phase, the blocking reagent, or a combination of any of the three. The second solid phase may be used in any or all parts of the assay although preferably eliminated at the "developer" stage. In the
30 case of human derived viral components as analyte, preinfected human components may be used as adsorbent reagent for the second solid phase partitioning.

The configuration for the second phase should be
35 designed for the mechanics of the reaction. Adsorbent

-17-

reagents would coat the chamber walls of the sample tray for some solutions. For rapid immunoassay, a critical step in controlling background is the initial mixing of solid phase and sample. The second solid phase should be free to move within the mixing solution (a second strip of any geometric shape or particles). A preferred method would employ an adsorbing means comprising a suspension of particle beads (approximate diameter of 1 to 10 micrometers) or any or all of the chambers into which the test strip is immersed. The advantage is a large total surface area for rapid reaction kinetics and maximum diffusion of reactants. Preincubation of sample with adsorbent coated particles would quickly remove background components before exposure to the test strip. Preparation of these types of particles is described in the examples.

Next the test strip is removed from well 25 and inserted into well 26. Well 26 may contain, for example, a premeasured quantity of a wash solution to remove interfering materials, or the like. Thereafter, the test strip is passed to a well 27 containing a detection system, for example, a labeled antigen, or a labeled antibody to the bound antigen or the like. Next, the strip may be moved to well 29 for washing and finally to well 30 where a substrate (e.g., chromogenic reagent) is added or already present. In some cases, excess liquid on the strip may be removed and substrate added directly to the strip. Other wells may be present to contain other reagents as required or desired.

Figure 3 illustrates an extension of the invention in which test block 22 includes a plurality of sets (i.e., 4 sets) of wells so that there are four sample wells

-18-

25, four wash wells 26, etc. This permits multiple samples to be tested at once with multiple test strips.

5 Figure 4 provides a block diagram of the typical test protocol just set forth and points out the sequential nature of the test method.

10 It will be appreciated by those skilled in the art that this invention is not limited to particular antibodies, reagents, particular samples, or particular utilization chemistries and that reasonable alternatives may be employed without departing from its teachings.

15 It should be noted that suitable antibodies for use in the test reagent region(s) may be monoclonal antibodies, polyclonal antibodies, mono- or divalent antibody fragments, hybrid antibodies, heterobifunctional antibodies, or genetically manipulated or cloned antibodies.

20 The test itself is, as noted above, a method of immunologically detecting the presence of one or more analytes in a specimen. Typically, the test is used in either the detection or the quantitation of bound or unbound label, wherein the amount of label detected
25 corresponds to the amount of analyte in the specimen. As used herein, the "immunoassay procedure" of the subject invention may be in the nature of immunoelectron microscopy of fluorescence polarization, or it
30 may be an immune-fluorescent or fluorescent immunoassay, a radiometric assay, an enzyme-linked immunoassay, or a photon-counting bioluminescent or chemiluminescent assay. In the case of the enzyme-linked immunoassay, the enzyme used is normally
35 selected from the group consisting of alkaline

-19-

phosphatase, glucose oxidase, horseradish peroxidase, urease, luciferase, and galactosidase. The label itself may be virtually any detectable species, e.g., a chromogenic compound, a radioactive isotope, an enzyme, or a fluorescent, luminescent, bioluminescent, chemiluminescent, phosphorescent, or ferromagnetic material.

The analyte may be virtually any compound or organism which is detectable using the aforementioned procedure, i.e., a drug, hormone, vitamin, enzyme, ligand, protein, including glycoprotein and lipoprotein, antibody, polysaccharide, cell or tissue antigen, or bacterium, protozoon, parasite, fungus, virus, blood cell substance, blood fluid substance, or a component of any of the foregoing. In a preferred embodiment, a plurality of analytes is detected, which in a particularly preferred embodiment includes HIV-1 GAG protein, HIV-1 ENV glycoprotein, HIV-1 POL protein, HTLV-1 GAG protein, HTLV-1 ENV glycoprotein, and HTLV-1 POL protein purified from natural isolates, recombinant genetic manipulations or chemical synthesis.

The aforementioned analytes may also be bound to the test strip as the actual detecting reagents in alternative assay procedures.

The specimen may be blood or its fractionated components, urine, saliva, vaginal fluid, seminal fluid, mucosa, birth fluids, tears, gastrointestinal fluid and excrement, inflammatory fluids, pleural effusion, pulmonary fluid, tissue extracts and the like derived from mammalian, avian, reptilian, amphibian, arthropod and the like.

-20-

In alternative embodiments, the specimen or sample to be tested may be an industrial sample, e.g. industrial waste chemicals or water, and the analyte may be an industrial pollutant or toxic chemical present therein.

5

The invention is further illustrated by the following examples which are not intended to and should not be construed so as to limit in any way the scope of the invention as defined by the claims which follow thereafter.

10

15

20

25

30

35

-21-

EXAMPLE 1Detection of Human Anti-HIV-1 Antibody in
One Assay Minimization of False Positives5 I. Preparation of the Test Stick

10 Test strip prototypes were constructed from the lids of 96-well tissue culture plates (Costar, catalog #3096). Strips were cut from the lid using a sharp knife attachment on a soldering iron so that the strip contained 8 contiguous circles, each surrounded by a raised peripheral ring. Strips can also be used as support segments to contain highly adsorbent solid phase (e.g., Nylon membrane or nitrocellulose paper).
15 The strip was washed in a buffer and allowed to air dry.

20 Monoclonal antibodies, designated DNP1 (CB6 mouse IgG1, specific for dinitrophenol) and anti-HIgG (CB6 mouse IgG1, specific for human immunoglobulin G) were gifts from Dr. Pao-Min Loh's laboratory (University of Iowa). Anti-HIV GAG (mouse IgG1, specific for Human Immunodeficiency Virus-1) was purchased from Epitope, Inc. (catalog #5001). Cocktails of MAbs with
25 specificity for each analyte can be used. Here, the MAbs were made 100 micrograms/ml in Tris Buffered Saline (TBS, 0.15 M NaCl, 0.05 M Tris, pH 7.2) and 10 microliters was applied directly to designated circular segments. HIV-1 (Litton Bionetics, HTLV-3, cat. #37225, 1 milligram/ml, NP40 inactivated) was made 2
30 micrograms/ml in TBS. 10 microliters were applied directly to the designated circular segment. The ordering of reagents was as follows:

35 Anti-human IgG (positive control) [top]

Anti-HIV GAG (detects virus antibody complex)

HIV-1 (detects antibody)

Anti-DNP (negative control) [bottom]

5 The stick was placed horizontally (solution side up) into a
45°C oven and the antibody and antigen allowed to dry for
about 30 minutes. The stick was placed in blocking solution
(TBS with 0.3% Tween, 1 mg/ml bovine serum albumin, BSA, and
0.1% sodium azide) for a minimum of 15 minutes.

10 (Note: Tween (trade mark) is a proprietary polyoxyethylene-
sorbitan monolavrate).

15 II. Preparation of Adsorbent Beads

To minimize the contribution of certain samples affinity to
bind to proteins denatured on solid surfaces (or solid
surfaces directly), latex polystyrene particles were
covalently coupled with monoclonal anti-DNP antibody (purified
human T-cell plasma membrane can also be coupled to latex
20 particles when viral analyte is either directly adsorbed or
chemically coupled). In addition, the nonspecific adsorbent
can be coated on any other solid phase or directly onto the
walls of the chamber. Antibody is made 200 micrograms/ml in
25 PBS (0.1 M phosphate-buffered saline, pH 7.2, Pandex
Laboratories published Research Report, No. 4 (1984) "Coupling
of Antigens to Latex Particles by the Water-Soluble
Carbodiimide Method," by Michael E. Jolley, Ph.D.). The
antibody solution was added to washed and pelleted latex
30 particles (Pandex, Epicon carboxyl-polystyrene particles,
catalog #31-010-1). The solution was triturated and exposed
to 20 sec of an ultrasonic water bath. The final
concentration of beads was 0.5%. Solid carbodiimide (Sigma,
1-ethyl-3-[3-dimethylaminopropyl]-carbodiimide, catalog
35 #E-7750) is added to make a final concentration of about 5



-23-

milligrams/ml. The solution is rotated gently for one hour at room temperature and washed (with PBS) and pelleted (12,000 x g, 3 min. room temperature) three times. The final bead solution is made 0.01% to 0.5% (w/v) in blocking buffer.

III. Sample Tray

A sample tray was configured by solvent welding plastic cuvettes (Elkay Products, catalog #127-1010-400) with a brand cyanocrylate glue. The cuvettes were 1 cm x 1 cm x 4.5 cm. In this example, the tray contains 7 cuvettes (with lids). In this example, the first compartment contained 2.5 ml of an approximately 1.0 micrograms/ml, inactivated HIV-1 (Litton Bionetics, HTLV-3, cat. #37225, 1 milligram/ml, NP40 inactivated) in blocking buffer containing about 0.1% adsorbent beads described above. The second compartment contained 2.5 milliliters wash solution (TBS/0.3% Tween). The third compartment contained a mixing solution (2.5 milliliters of blocking solution with about 0.1% adsorbent beads) for diluting the human blood specimen. The fourth compartment contained 2.5 milliliters wash solution (TBS/0.3% Tween). The fifth compartment contained 2.5 milliliters of developing conjugate solution; polyclonal goat anti-human immunoglobulin coupled to alkaline phosphatase (Jackson Immunoresearch Labs, catalog #109-5576) diluted 1:500 in blocking solution with about 0.1% adsorbent beads. The sixth compartment contained 2.5 milliliters of wash solution (TBS/0.3% Tween). The seventh compartment contained 2.5 milliliters of presubstrate wash solution (pH 10 alkaline buffer).

-24-

IV. The Assay

5 The lid for chamber #3 was removed. A drop of blood (obtained by a lancet puncture to a finger alternatively, 1 to 50 microliters of serum may be used) was allowed to drip into the third compartment. With each chamber covered with its respective lid, the entire tray was gently shaken several times to ensure mixing of blood and bead solution. The tray was returned to its original standing position and the lid removed from chamber #1. While the blood was incubating in chamber #3, a test strip was immersed in chamber #1. The solution was gently stirred with the test strip and allowed to incubate at 42°C for about 20 minutes. Care was taken to ensure that the readable was maximally exposed to the solvent phase. The strip was transferred to compartment #2 and washed for about 10 seconds. The strip was transferred to compartment #3 containing the blood/adsorbent mixture. The solution was gently mixed and allowed to incubate with the strip for about 30 minutes at 42°C. The strip was transferred to compartment #4 and washed for about 10 seconds. The strip was transferred to compartment #5. With about 5 seconds of gentle stirring, the strip was allowed to incubate (stirring every 1 min.). After a total of about 10 minutes incubation, the strip was transferred to compartment #6 and gently stirred for about 10 seconds. The strip was transferred to compartment #7 and washed for about 10 seconds. The strip was removed and tapped lightly to remove excess liquid. One drop (about 50 microliters) of substrate (5-bromo-4-chloro-3-indolyl phosphate, Sigma catalog #B-0766, in alkaline buffer, pH 10) was added to each readable area. After approximately 10 minutes, the

35

-25-

color reaction of each readable area was recorded as positive (blue color) or negative (no color).

V. Interpretation

5

10

15

20

25

30

35

The assay can only be valid if the segment containing the anti-DNP MAb (negative control) remains colorless. The adsorbent beads should remove all materials that cause a false positive reaction and the negative control readable area was used to confirm this function. The anti-HIg segment should bind human immunoglobulin present in blood samples. This reaction must be positive or else the test reagents are not working, thus invalidating the test. A positive blue color in the HIV-1 segment indicates that there is antibody to HIV-1 present in the blood sample. A positive response in the anti-HIV segment suggests that virus is present complexed with human anti-HIV antibody.

-26-

EXAMPLE 2Detection of Human Anti-HIV-1 Antibody
Minimization of False Positives5 I. Preparation of the Test Stick

10 Test strip prototypes were constructed from the lids of 96-well tissue culture plates (Costar, catalog #3096). Strips were cut from the lid using a sharp knife attachment on a soldering iron so that the strip contained 8 contiguous circles, each surrounded by a raised peripheral ring. Strips can also be used as support segments to contain highly adsorbent solid phase (e.g., Nylon membrane or nitrocellulose paper), also, sticks can be constructed in such a way that can contain recessed reactive areas. The strip was washed in a buffer and allowed to air dry.

15 Monoclonal antibodies, designed DNP1 (CB6 mouse IgG1, specific for dinitrophenol) and anti-HIgG (CB6 mouse IgG1, specific for human immunoglobulin G) were used. Cocktails of MABs with specificity for each analyte can be used. Here, the MABs were made 100 micrograms/ml in Tris Buffered Saline (TBS, 0.15 M NaCl, 0.05 M Tris, pH 7.2) and 10 microliters applied directly to designated circular segments. HIV-1 (Litton Bionetics, HTLV-3, cat. #37225, 1 milligram/ml, NP40 inactivated) was made 2 micrograms/ml in TBS. 10 microliters were applied directly to the designated circular segment. The ordering of reagents was as follows:

30 Anti-human IgG (positive control) [top]
HIV-1 (detects antibody) [middle]
Anti-DNP (negative control) [bottom]

35

-27-

5 The stick was placed horizontally (solution side up) into a 45°C oven and the antibody allowed to dry for about 30 minutes. The stick was placed in blocking solution (TBS with 0.3% Tween, 1 mg/ml bovine serum albumin, BSA, and 0.1% sodium azide) for a minimum of 15 minutes.

10 II. Preparation of Adsorbent Beads

15 To minimize the contribution of certain samples' affinity to bind to proteins denatured on solid surfaces (or solid surfaces directly), latex polystyrene particles were covalently coupled with monoclonal anti-DNP antibody (purified human T-cell plasma membrane or recombinant DNA related proteins such as beta-galactosidase can also be coupled to latex particles when viral analyte is either directly adsorbed or chemically coupled). In addition, the non-specific adsorbent can be coated on any other solid phase or directly onto the walls of the chamber. 20 Antibody is made 200 micrograms/ml in PBS (0.1 M phosphate-buffered saline, pH 7.2, Pandex Laboratories published Research Report, No. 4 (1984) "Coupling of Antigens to Latex Particles by the Water-Soluble Carbodiimide Method," by Michael E. Jolley, Ph.D.). 25 The antibody solution was added to washed and pelleted latex particles (Pandex, Epicon carboxyl-polystyrene particles, catalog #31-010-1). The solution was triturated and exposed to 20 sec of an ultrasonic water bath. The final concentration of beads was 0.5%. 30 Solid carbodiimide (Sigma, 1-ethyl-3-[3-dimethylaminopropyl]-carbodiimide, catalog #E-7750) is added to make a final concentration of about 5 milligrams/ml. The solution is rotated gently for one hour at room temperature and washed (with PBS) and 35

-28-

pelleted (12,000 x g, 3 min., room temperature) three times. The final bead solution is made 0.01% to 0.5% (w/v) in blocking buffer.

5 III. Sample Tray

10 A sample tray was configured by solvent welding plastic cuvettes (Elkay Products, catalog #127-1010-400) with a cyanoacrylate glue. The cuvettes were 1 cm x 1 cm x 4.5 cm. In this example, the tray contains 6 cuvettes (with lids). The first chamber contained a mixing solution (2.5 milliliters of blocking solution with about 0.1% adsorbent beads) for diluting the human blood specimen. The second chamber contained 2.5 milliliters wash solution (TBS/0.3% Tween). The third chamber contained 2.5 milliliters of developing conjugate; polyclonal goat anti-human immunoglobulin coupled to alkaline phosphatase (Jackson Immunoresearch Labs, catalog #109-5576) diluted 1:500 in blocking solution. The fourth chamber contained 2.5 milliliters of wash solution (TBS/0.3% Tween). The fifth chamber contained 2.5 milliliters of presubstrate wash solution (pH 10 alkaline buffer). The sixth chamber contained 1 ml of substrate solution (5-bromo-4-chloro-3-indolyl phosphate, Sigma catalog #B-0766, in alkaline buffer, pH10).

25 IV. The Assay

30 The sample tray was equilibrated in a 42° water bath. 5 microliters (5-200 microliters can be used) of serum or plasma was added into the first chamber. The sample in chamber 1 was allowed to incubate for 3 minutes at 42°C. (40-45°C may be used). The solution was gently stirred with the test strip and allowed to incubate at 35

-29-

42°C for about 45 minutes. Care was taken to ensure that the readable area was maximally exposed to the solvent phase. The strip was transferred to chamber #2 and washed for about 1-10 seconds. The strip was transferred to chamber #3. With about 5 seconds of gentle stirring, the strip was allowed to incubate at 42°C for about 45 minutes. The strip was transferred to chamber #4 and gently stirred for about 1-10 seconds. The strip was transferred to chamber #5 and washed for about 1-10 seconds. The entire sample tray was removed from the 42°C water bath and placed on the bench at room temperature. The strip was transferred to chamber #6 and allowed to incubate at room temperature for 10-20 minutes. The color reaction of each readable area was recorded as positive (blue color) or negative (no color).

Three double-blind studies were performed to determine the presence of antibodies to HIV-1 in patient serum.

Test A: 25 out of 50 serum samples (Peralta Cancer Center, Oakland, CA) were Western Blot (WB) positive for HIV-1 antibodies (predominantly gp41 only). The other 25 were from a WB negative donor serum pool. The test accurately identified 100% of the samples as negative or positive as compared with the WB results.

Test B: 21 HIV-1 WB positive blood samples, and 7 false positive blood samples (as originally screened on the Abbott HIV-1 antibody test at the Massachusetts General Hospital Blood Bank, Boston, MA) were tested with the test. In the test, all 21 WB positive samples were confirmed along with the 23 WB negative samples. All 7 false positive samples were negative by the test.

Test C: 9 HIV-1 WB positive blood samples (NYU Medical Center) and 10 WB negative blood samples were correctly identified by the test. Two HIV-1 antibody positive semen samples, two saliva samples and 1 urine sample were also positive in the test.

5

10

15

20

25

30

35

EXAMPLE 3Detection of HIV-1 P24 Antigen in Patient's SerumI. Preparation of the Test Sticks

5 Test sticks are the same as those in Example 1. The following monoclonal antibodies are adsorbed to the stick: 1F8 (Calypte Biomedical Company's anti HIV-1 GAG monoclonal antibody, IgG1); anti-HIgG and anti-DNP. Here, the MAbs were made 100 milligram/ml in Tris Buffered Saline and 10 microliters applied directly to a designated circular segment. The ordering of MAbs was as follows:

15 Anti-Human IgG (positive control) [top]
Anti-HIV GAG (detects P24) [middle]
Anti-DNP (negative control) [bottom]

20 The stick is placed horizontally solution side up into a 45°C oven and antibodies allowed to adsorb for about 60 minutes. The stick was placed in blocking solution (PBS, 5% horse serum) for a minimum of 15 minutes.

II. Preparation of the Adsorbent Beads

25 To minimize the contribution of certain samples' affinity to bind to proteins denatured on solid surfaces (or solid surfaces directly) and to effect removal of contaminating human anti-GAG (soluble or in complexes), latex polystyrene particles were covalently coupled with recombinant HIV-1 p24 GAG protein. The recombinant antigen is made 100-200 micrograms/ml in PBS. The antigen solution was added to washed and pelleted latex particles. The solution was triturated and exposed for 20 seconds of an ultrasonic bath. The final concentration of beads was 0.5%. Solid



-32-

carbodiimide is added to make a final concentration of about 5 milligrams per ml. The solution is rotated gently for one hour at room temperature and washed (with PBS) and pelleted (12,000 x g) three minutes, room temperature 3 times. The final bead solution is made 0.01% to 0.5% (w/v) in blocking buffer.

III. Sample Tray

The first compartment contained 2.5 ml of blocking buffer containing about 0.1% recombinant antigen adsorbent beads described above. The second compartment contained 2.5 milliliters wash solution (TBS). The third compartment contained 2.5 milliliters of developing conjugate solution; polyclonal goat anti-HIV-1 GAG coupled to alkaline phosphatase diluted 1:500 in blocking solution. The fourth compartment contained 2.5 milliliters of wash solution (TBS). The fifth compartment contained 2.5 milliliters of presubstrate wash solution (ph 10 alkaline buffer).

IV. The Assay

100 microliters of patient sample (blood, serum, plasma) is added to a shallow well, containing twenty microliters of dissociation buffer (1 M HCl-glycine buffer). The solution is then transferred into chamber #1. The solution was gently stirred with the test strip and allowed to incubate at 42°C for about 20 minutes. Care was taken to ensure that the readable area was maximally exposed to the solvent phase. The strip was transferred to compartment #2 and washed for about 10 seconds. The strip was transferred to compartment #3 with about five seconds of gentle stirring. The strip was allowed to incubate for about

-33-

20 minutes at 42°C. The strip was transferred to compartment #4 and gently stirred for about 10 seconds. The strip was transferred to compartment #5 and washed for about 10 seconds. The strip was removed and tapped lightly to remove excess liquid. One drop (about 50 microliters) of substrate (5-bromo-4-chloro-3-indolyl phosphate, Sigma catalog #B-0766, in alkaline buffer, pH 10) was added to each readable area. After approximately 10 minutes, the color reaction of each readable area was recorded as positive (blue color) or negative (no color).

5

10

15

20

25

30

35

The claims defining the invention are as follows:

1. A test strip for detecting a target analyte comprising an antibody based analyte or antigenic substance in a sample from a human subject which comprises

(a) a solid support;

(b) a reagent directed against the target analyte bound to a first discrete area on the solid support wherein when said target analyte is an antigenic substance said reagent is an antibody-based reagent and wherein when said target analyte is an antibody said reagent is an antigenic substance which binds said antibody;

(c) an antihuman antibody which binds to an antigen which naturally occurs in human subjects said anti-human antibody being bound to a second discrete area on the solid support as a positive control;

(d) an antibody directed against an antigen which does not naturally occur in human subjects and which is different from said analyte bound to a third discrete area on the solid support as a negative control.

2. A test strip according to claim 1 for detecting, in a sample from a human subject, the presence of a target antigenic substance wherein the said reagent is an antibody or fragment thereof directed against the target antigenic substance.

3. A test strip according to claim 1 for detecting, in a sample from a human subject, the presence of a target antibody wherein said reagent is an antigenic substance which binds the target antibody.



4. A test strip, in a sample from a human subject, the presence of a target human antibody and a target antigenic substance which comprises:

5 a) a solid support;
b) an antigenic substance which binds the target human antibody bound to a first discrete area on the solid support;

10 c) an antibody or fragment thereof directed against the target antigenic substance bound to a second discrete area on the solid support;

d) an antibody or fragment thereof which binds to a human antigen known to be present in the sample bound to a third discrete area on the solid support as a positive control;

15 e) an antibody or fragment thereof directed against an antigen which does not naturally occur in human subjects and which is directed against an antigen different to said target antigenic substance bound to a fourth discrete area on the solid support as a negative control; and

20 f) an antigen which does not naturally occur in human subjects and is directed to an antibody different to said target human antibody as a second negative control bound to a fifth discrete area on the solid support.

25 5. A test strip of claim 4 additionally comprising an antibody or fragment thereof directed against the target antigenic substance; which substance is in an immune complex with a naturally occurring human antibody thereto, bound to the second discrete area on the solid support.

30 6. A test strip of any one of claims 1, 2, 4 and 5, wherein the antigenic substance is a virus or a viral protein.

35 7. A test strip of claim 6, wherein the antigenic substance is HIV-1, HIV-1 GAG protein, HIV-1 ENV glycoprotein, HIV-1 POL protein, HIV-2, HIV-2 GAG protein, HIV-2 ENV glycoprotein, HIV-2 POL protein, HTLV-1 GAG protein, HTLV-1 ENV glycoprotein, HTLV-1 POL protein, Hepatitis B surface antigen or an epitope thereof.



8. A test strip of any one of claims 1, 3 or 4, wherein the antibody or fragment thereof is directed against HIV-1, HIV-1 GAG protein, HIV-1 ENV glycoprotein, HIV-1 POL protein, HIV-2, HIV-2 GAG protein, HIV-2 ENV glycoprotein, HIV-2 POL protein, HTLV-1, HTLV-1 GAG protein, HTLV-1 ENV glycoprotein, HTLV-1 POL protein, a Hepatitis B core antigen, or an epitope thereof.

9. A test strip of any one of claims 1 to 10 wherein the solid support comprises glass fiber filter paper, nitrocellulose, scintered glass, plastic, cellulose, or cellulose acetate.

10. A test strip of any one of claims 1, 2, 4 or 5 wherein the antibody or fragment thereof comprises a monoclonal antibody, polyclonal antibody, mono- or divalent antibody fragment, hybrid antibody, heterobifunctional antibody, or genetically manipulated or cloned antibody.

11. A test strip of any one of claims 1 to 5 wherein the antigen which does not naturally occur in human subjects is a synthetic organic molecule.

12. A method for detecting in a sample from a human subject the presence of a target antigenic substance which comprises:

(a) pretreating the sample to be tested so as to prevent non-specific and specific binding of substances present in the sample to proteins, including antibodies and recombinant antigens present on the test strip, and thus prevent spurious results;

(b) contacting the resulting pretreated sample with the test strip under conditions such that an antibody bound to the test strip and directed against the target antigenic substance forms a



complex with the antigenic substance in the pretreated sample;

- 5
- (c) thereafter washing the test strip to remove target antigen that is not complexed with the antibody bound to the test strip;
- 10
- (d) contacting the resulting, treated test strip with labelled antibody to the target antigenic substance under conditions such that the labelled antibody forms a complex with the target antigenic substance complexed to the antibody bound to the test strip;
- 15
- (e) detecting the presence of labelled antibody complexed to the test strip, and thereby the presence of the target antigenic substance in the sample; and
- 20
- (f) verifying the correctness of the detection so made by determining that a positive control is labelled and a negative control is not labelled on the test strip.

25

13. A method for detecting in a sample from a human subject the presence of a target human antibody directed to an antigenic substance on which comprises:

- 30
- (a) adding to the sample to be tested a pretreatment material so as to prevent simultaneously non-specific and specific binding of nontarget substances present in the sample to a test strip, and thus preventing false positive results;
- 35
- (b) contacting the resulting pretreated sample with the test strip under conditions such that an antigenic substance bound to the test strip forms a complex with any target human antibody



directed against it which is present in the sample;

- (c) thereafter washing the test strip to remove target human antibody that is not complexed with the antigenic substance bound to the test strip;
- (d) contacting the resulting, treated test strip with labelled antibody which binds to human immunoglobulins under conditions such that the antibody forms a complex with any target human antibody complexed to the antigenic substance bound to the test strip;
- (e) detecting the presence of labelled antibody which binds to human immunoglobulins complexed to the test strip, and thereby the presence of target human antibody in the sample; and
- (f) verifying the correctness of the detection so made by determining that a positive control is labelled and a negative control is not labelled on the test strip.

14. A method for detecting in a sample from a human subject the presence of a target antigenic substance and a target human antibody directed to an antigenic substance which comprises:

- (a) adding to the sample to be tested a pretreatment material so as to prevent simultaneously non-specific and specific binding of nontarget substances present in the sample to a test strip, and thus preventing false positive results;
- (b) contacting the resulting pretreated sample with the test strip under conditions such that an



antibody bound to the test strip and directed against the target antigenic substance forms a complex with the target antigenic substance which is present in the sample and an antigenic substance bound to the test strip forms a complex with any target human antibody directed against it which is present in the sample;

5
10
15
(c) thereafter washing the test strip to remove target human antibody that is not complexed with the antigenic substance bound to the test strip and to remove any target antigenic substance not complexed with antibody directed against the target antigenic substance bound to the test strip;

20
25
(d) contacting the resulting, treated test strip with labelled antibody to the target antigenic substance and labelled antibody which binds to human immunoglobulin under conditions such that the labelled antibody forms a complex with the target antigenic substance complexed to the antibody bound to the test strip and the labelled antibody which binds to human immunoglobulins forms a complex with any target human antibody complexed to the test strip;

30
(e) detecting the presence of labelled antibody and labelled antibody which binds to human immunoglobulins complexed to the test strip, and thereby the presence of the target antigenic substance and target human antibody in the sample; and

35
(f) verifying the correctness of the detection so made by determining that a positive control is labelled and the negative controls are not labelled on the test strip.



15. A method for detecting in a sample from a human subject the presence of a target antigenic substance and a target human antibody directed to an antigenic substance which comprises:

- 5
- (a) adding to the sample to be tested a pretreatment material so as to prevent simultaneously non-specific and specific binding of nontarget substances present in the sample to a test strip, and thus preventing false positive results;
- 10
- (b) contacting the resulting pretreated sample with the test strip under conditions such that an antibody bound to the test strip and directed against the target antigenic substance forms a complex with the target antigenic substance and an antigenic substance bound to the test strip forms a complex with any target human antibody directed against it which is present in the sample;
- 15
- (c) thereafter washing the test strip to remove target human antibody that is not complexed with the antigenic substance bound to the test strip and to remove any target antigenic substance not complexed with antibody directed against the target antigenic substance bound to the test strip;
- 20
- 25
- (d) contacting the resulting, treated test strip with labelled antibody to the target antigenic substance and labelled antibody which binds to human immunoglobulins under conditions such that the labelled antibody forms a complex with the target antigenic substance complexed to the antibody bound to the test strip and the antibody which binds to human immunoglobulins forms a complex with any target human antibody
- 30
- 35
- 39



complexed to the test strip;

5 (e) contacting the resulting treated test strip with an antibody-based reagent directed against the target antigenic substance in an immune complex and naturally-occurring human antibody thereto;

10 (f) detecting the presence of labelled antibody and labelled antibody which binds to human immunoglobulins complexed to the test strip, and thereby the presence of the target antigenic substance and target human antibody in the sample; and

15 (g) verifying the correctness of the detection so made by determining that a positive control is labelled and the negative controls are not labelled on the test strip.

20 16. A method of any one of claims 12 to 15 wherein the antigenic substance is a virus or viral protein.

25 17. A method of any one of claims 12 to 15 wherein the sample is blood or serum.

18. A method of any one of claims 12 to 15 wherein the sample is urine, saliva or semen.

30 19. A method of claim 18, wherein the urine is unconcentrated.

35 20. The method of any one of claims 13 to 15 wherein the target human antibody is directed to HIV-1 viral envelope glycoprotein gp160.

21. The test strip of claim 9 wherein the plastic is synthetic polymer.



22. The test strip of claim 21 wherein the synthetic polymer is selected from a group consisting of polystyrene, polytetrafluoroethylene, polyethylene, polypropylene, or polyvinylidene fluoride.

23. A test strip according to any one of the claims selected from claims 1 to 11, claim 21 and claim 22 substantially as herein described with reference to any one of the Examples.

24. A method according to any one of claims 12 to 20 substantially as herein described with reference to any one of the Examples.

DATED: 14 July 1992

PHILLIPS ORMONDE & FITZPATRICK

Attorneys for:

CALYPTE BIOMEDICAL COMPANY

David B Fitzpatrick

0614S

20
25

30

35



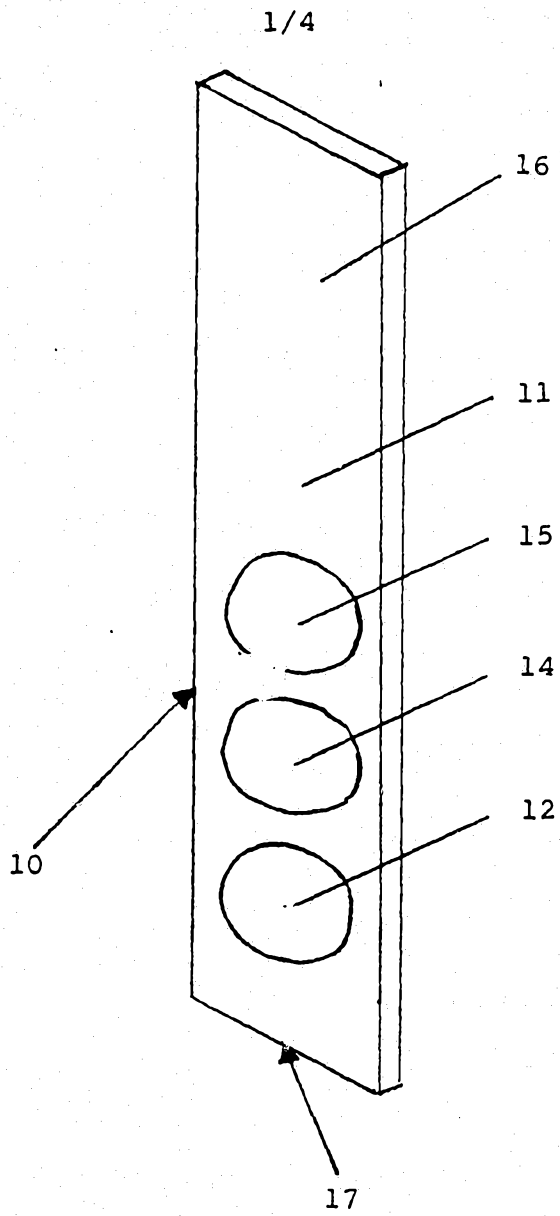

FIGURE 1

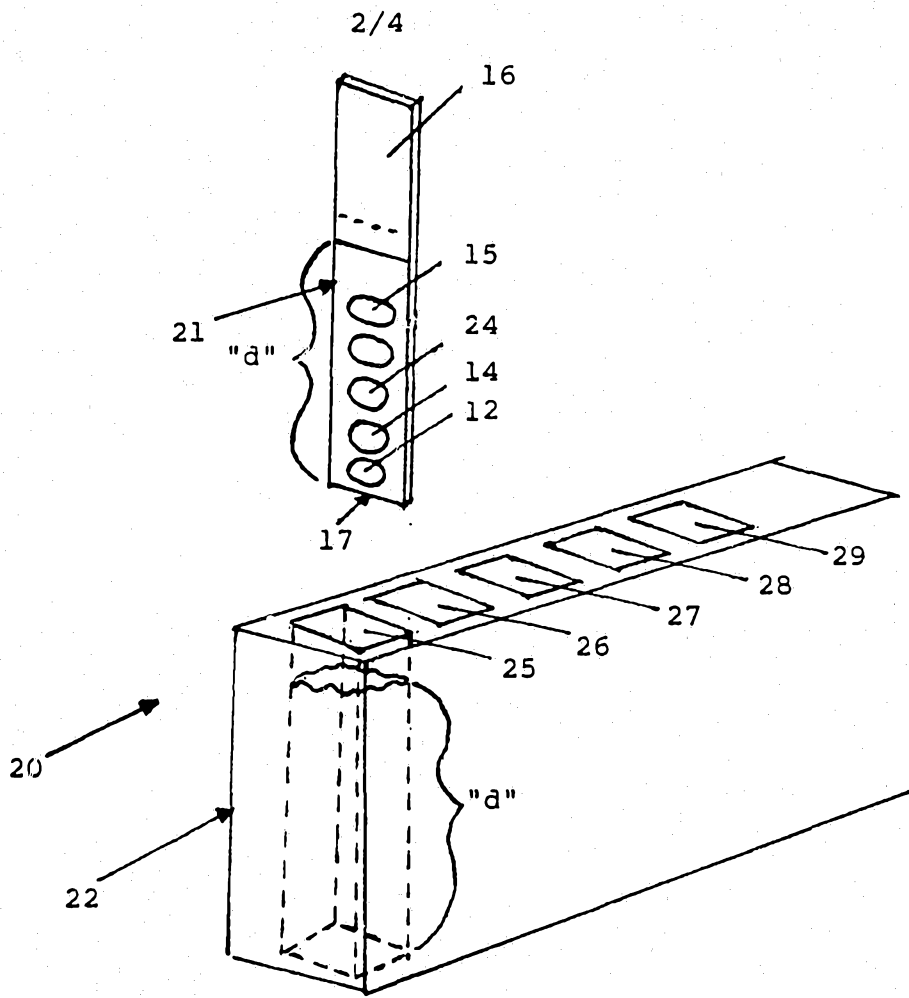

FIGURE 2

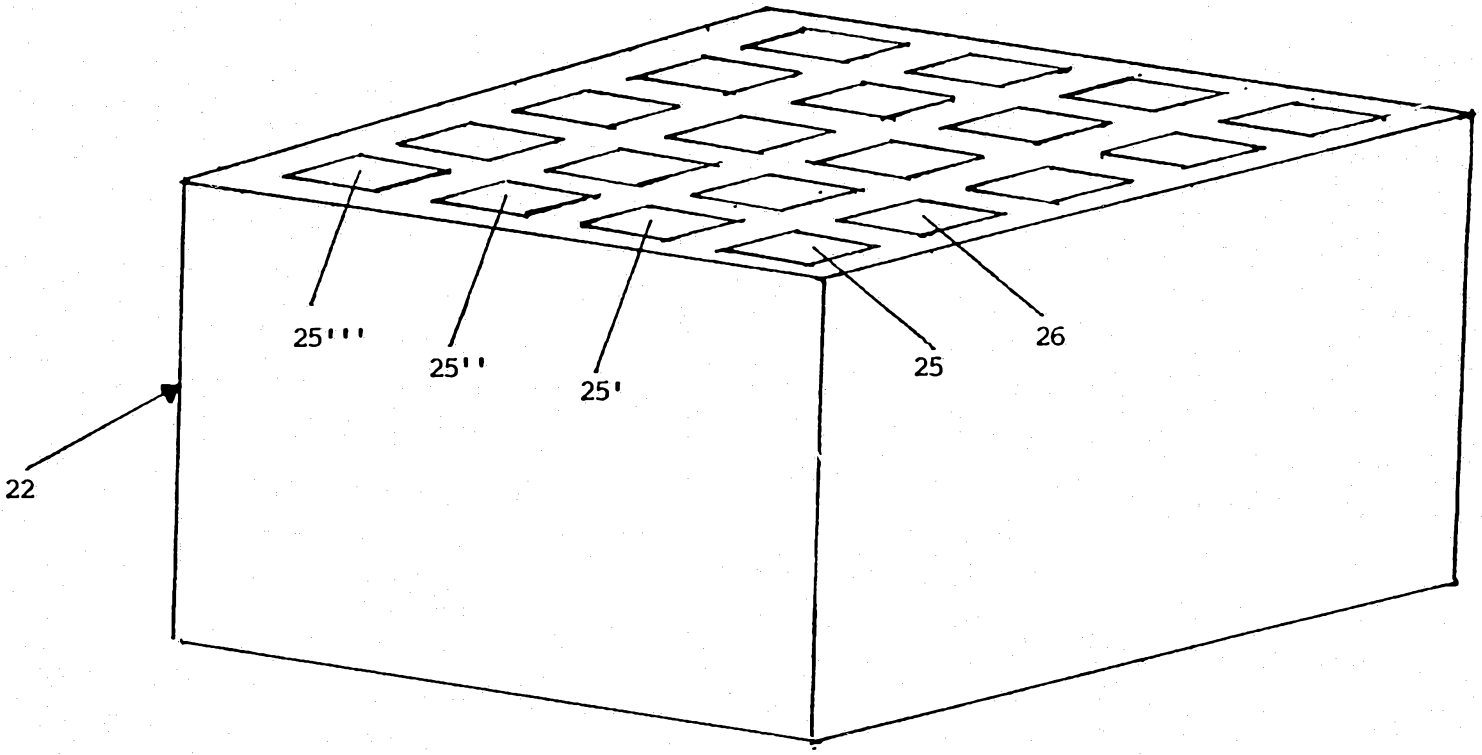

FIGURE 3

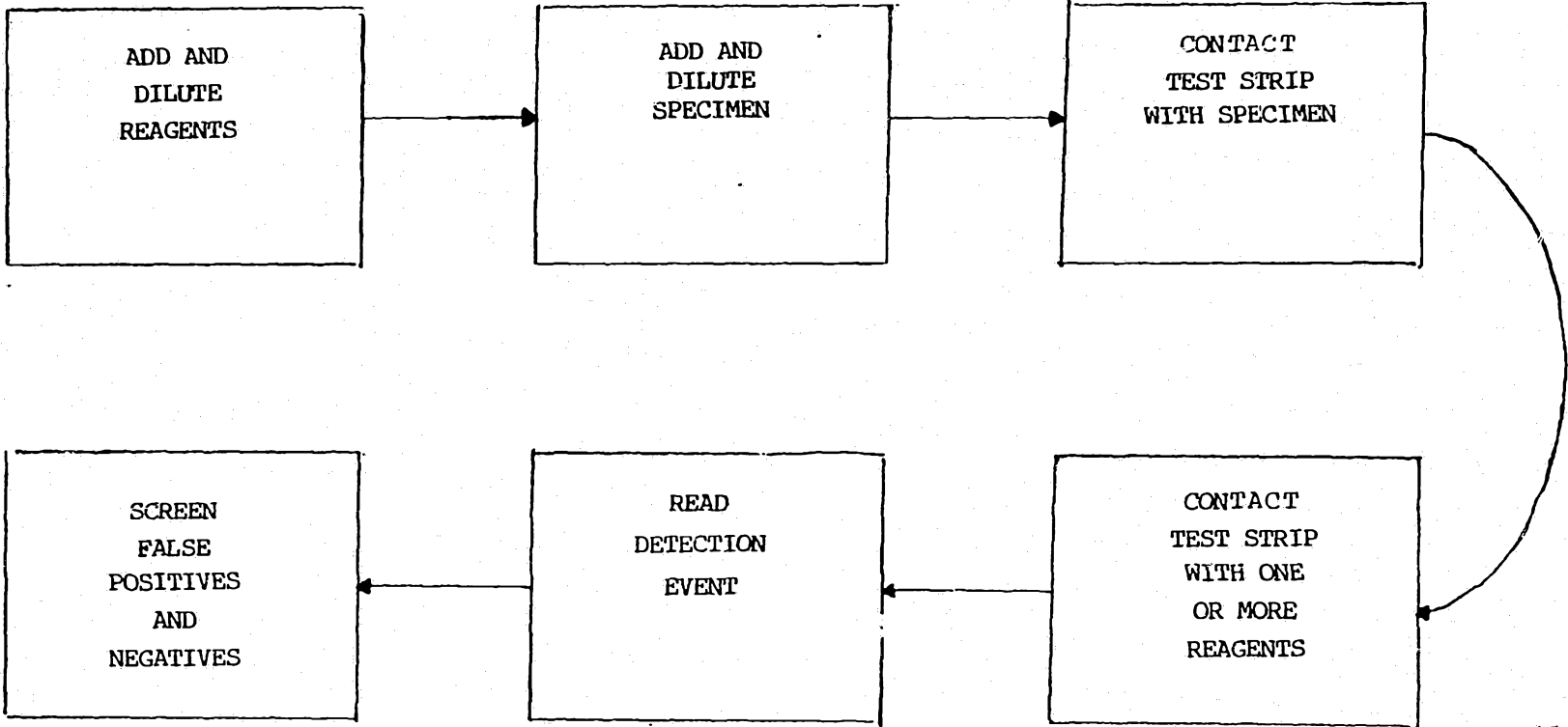

FIGURE 4

INTERNATIONAL SEARCH REPORT

International Application No. PCT/US88/02684

| | | |
|--|---|---|
| I. CLASSIFICATION OF SUBJECT MATTER (If several classification symbols apply, indicate all) ⁶ | | |
| According to International Patent Classification (IPC) or to both National Classification and IPC IPC(4): G01N 33/543, 545, 552, 53; C12Q 1/68 U.S. CL.: 435/4,6,7; 436/518, 527, 531; 422/56,57 | | |
| II. FIELDS SEARCHED | | |
| Minimum Documentation Searched ⁷ | | |
| Classification System | Classification Symbols | |
| U.S. | 436/518, 527, 531 435/4, 6, 7, 422/56, 57 | |
| Documentation Searched other than Minimum Documentation to the Extent that such Documents are Included in the Fields Searched ⁸ | | |
| CAS, BIOSIS, APS DATABASES | | |
| III. DOCUMENTS CONSIDERED TO BE RELEVANT ⁹ | | |
| Category * | Citation of Document, ¹¹ with indication, where appropriate, of the relevant passages ¹² | Relevant to Claim No. ¹³ |
| X, P Y | EP, A, 0253464 (VALKIRS ET AL) 20 January 1988 (20.01.88) (Note: Abstract; page 2, lines 39-43, 48-50; page 3, lines 24-36; page 5, lines 3-4; page 6, lines 12-19; page 8, lines 10-29) | 1,5-7,11 2-4,8-10 12-17 |
| Y | US, A, 4,299,916 (LITMAN ET AL) 10 November 1981 (10.11.81) (Note: column 4, line 67 - column 5, line 7; column 6, lines 33-39; column 15, lines 14-61; column 19, line 68 - column 20, line 2; column 25, lines 22-64) | 1,3-7, 13-17 |
| Y | US, A, 4,540,659 (LITMAN ET AL) 10 September 1985 (10.09.85) (Note: Abstract; column 7, line 8 - column 8, line 30) | 1-7, 11-17 |
| <p>* Special categories of cited documents: ¹⁰</p> <p>"A" document defining the general state of the art which is not considered to be of particular relevance</p> <p>"E" earlier document but published on or after the International filing date</p> <p>"L" document which may throw doubts on priority claim(s) or which is cited to establish the publication date of another citation or other special reason (as specified)</p> <p>"O" document referring to an oral disclosure, use, exhibition or other means</p> <p>"P" document published prior to the International filing date but later than the priority date claimed</p> <p>"T" later document published after the international filing date or priority date and not in conflict with the application but cited to understand the principle or theory underlying the invention</p> <p>"X" document of particular relevance; the claimed invention cannot be considered novel or cannot be considered to involve an inventive step</p> <p>"Y" document of particular relevance; the claimed invention cannot be considered to involve an inventive step when the document is combined with one or more other such documents, such combination being obvious to a person skilled in the art.</p> <p>"&" document member of the same patent family</p> | | |
| IV. CERTIFICATION | | |
| Date of the Actual Completion of the International Search | | Date of Mailing of this International Search Report |
| 04 November 1988 (04.11.88) | | 4 JAN 1989 |
| International Searching Authority | | Signature of Authorizing Officer |
| ISA/US | | <i>Carol A. Spiegel</i> CAROL A. SPIEGEL |

| III. DOCUMENTS CONSIDERED TO BE RELEVANT (CONTINUED FROM THE SECOND SHEET) | | |
|--|---|------------------------------------|
| Category * | Citation of Document, ¹⁶ with indication, where appropriate, of the relevant passages ¹⁷ | Relevant to Claim No ¹⁸ |
| Y | US, A, 4,558,013 (MARINKOVICH ET AL) 10 December 1985 (10.12.85) (Note: Abstract, column 2, lines 7-19; column 3, lines 3-22) | 1-7, 10-17 |
| Y | EP, A, 017150 (HERZBERG ET AL) 12 February 1986 (12.02.86) (Note: Abstract; page 6, lines 12-15; page 7, lines 17-21; page 10, lines 11-14; page 42, lines 3-5; page 46, lines 13-20; page 56, lines 1-18; page 58, lines 11-14, page 59, lines 12-15) | 1-17 |
| Y | EP, A, 0200381 (RUBENSTEIN) 05 November 1986 (05.11.86) (Note: page 3, lines 8-11; page 4, lines 23-30; page 6, lines 17-30; page 11, lines 5-25; page 15, lines 10-24) | 1-17 |
| Y | EP, A, 0217403 (BROWN ET AL) 08 April 1987 (08.04.87) (Note: Column 3, lines 46-48; column 4, lines 33-36; column 13, lines 26-28; column 15, lines 7-34; column 16, line 56 - column 17, line 2) | 1,3,5,6 |
| Y | Biological Abstracts, Volume 79, Number 11: issued 01 June 1985 (Philadelphia, Pennsylvania, USA, W.C. GOH, "Subcellular localization of the product of the long open reading frame of human T cell leukemia virus type I," see page 368, column 1 the abstract No. 94949 SCIENCE (Washington D.C.) 227(4691): 1227-1228, 1985 (English)). | 4 |
| Y, P | Biological Abstracts, Volume 84 Number 10: issued 15 September 1987 (Philadelphia, Pennsylvania USA, A.G. FISHER, "The sor gene of HIV-1 is required for efficient virus transmission in vitro," see page 1160, column 1, the abstract No. 104387, SCIENCE (Washington, D.C.) 237(4817): 888-893, 1987 (English)). | 4 |