



(19) **United States**

(12) **Patent Application Publication**

(10) **Pub. No.: US 2007/0261612 A1**

**Alcov**

(43) **Pub. Date:**

**Nov. 15, 2007**

(54) **MULTI-PURPOSE VARIABLE HEIGHT TABLE AND CHAIRS**

(52) **U.S. Cl.** ..... 108/144.11

(76) Inventor: **Nicholas Alcov**, Arroyo Grande, CA (US)

(57) **ABSTRACT**

Correspondence Address:  
**Nicholas Alcov**  
**2398 Callender Rd.**  
**Arroyo Grande, CA 93420 (US)**

Disclosed is a multi-purpose variable height table-chair combination comprising: a variable height table having a table top, table legs supporting the table top, the table top is engaged to top ends of the table legs, and at least one set of height varying adapters removably disposed between the table legs, the height varying adapters configured to raise a height of the variable height table when engaged to bottom ends of the table legs; and a variable height chair having a seat, chair legs supporting the seat and at least one set of height varying adapters disposed between the chair legs, the height varying adapters configured to raise a height of the variable height chair when engaged to bottom ends of the chair legs, corresponding to the raise in the height of the variable height table. The multi-purpose variable height table-chair combination provides fast, easy, convenient and inexpensive manner for serving different purposes.

(21) Appl. No.: **11/431,045**

(22) Filed: **May 10, 2006**

**Publication Classification**

(51) **Int. Cl.**  
**A47B 9/00** (2006.01)  
**A47C 3/20** (2006.01)

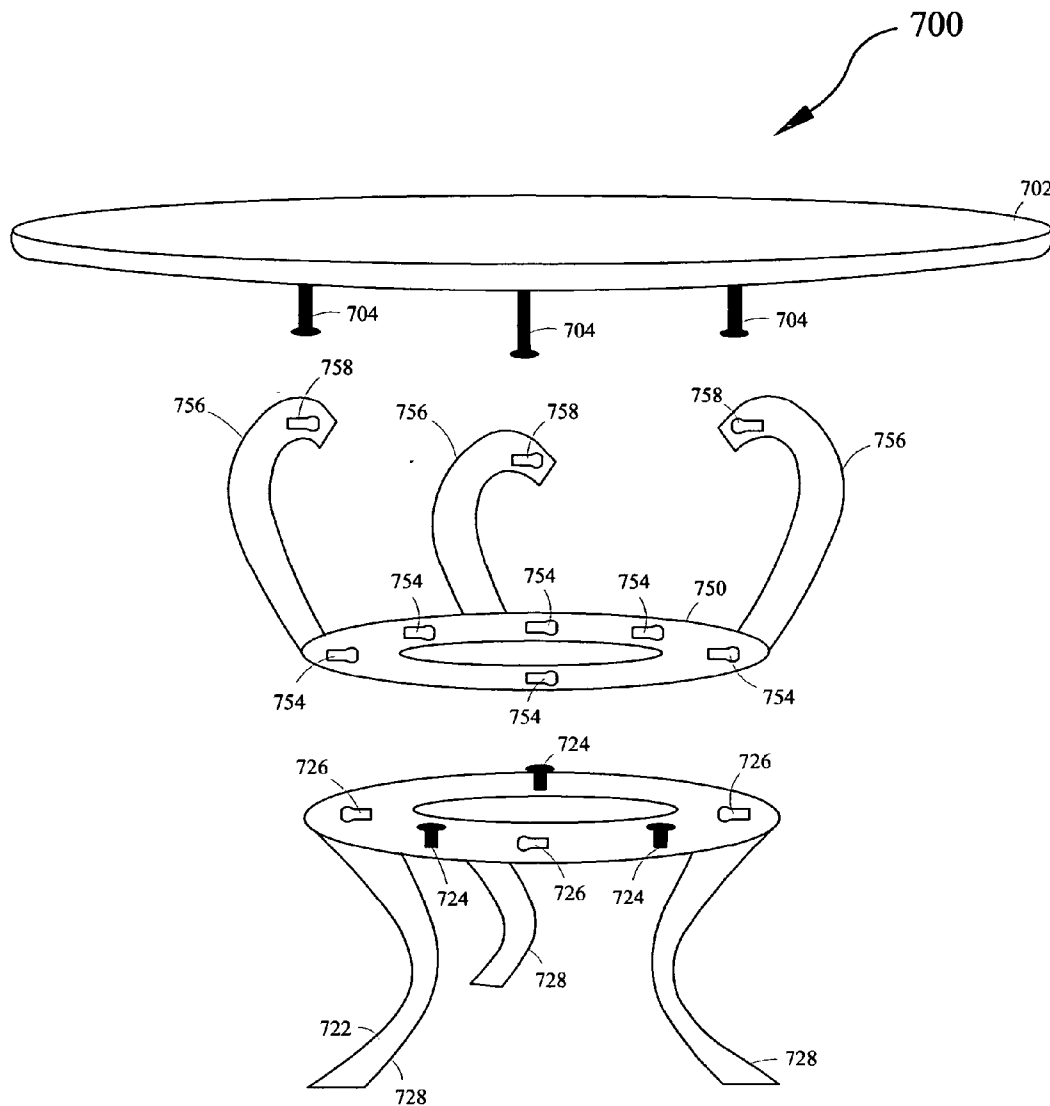

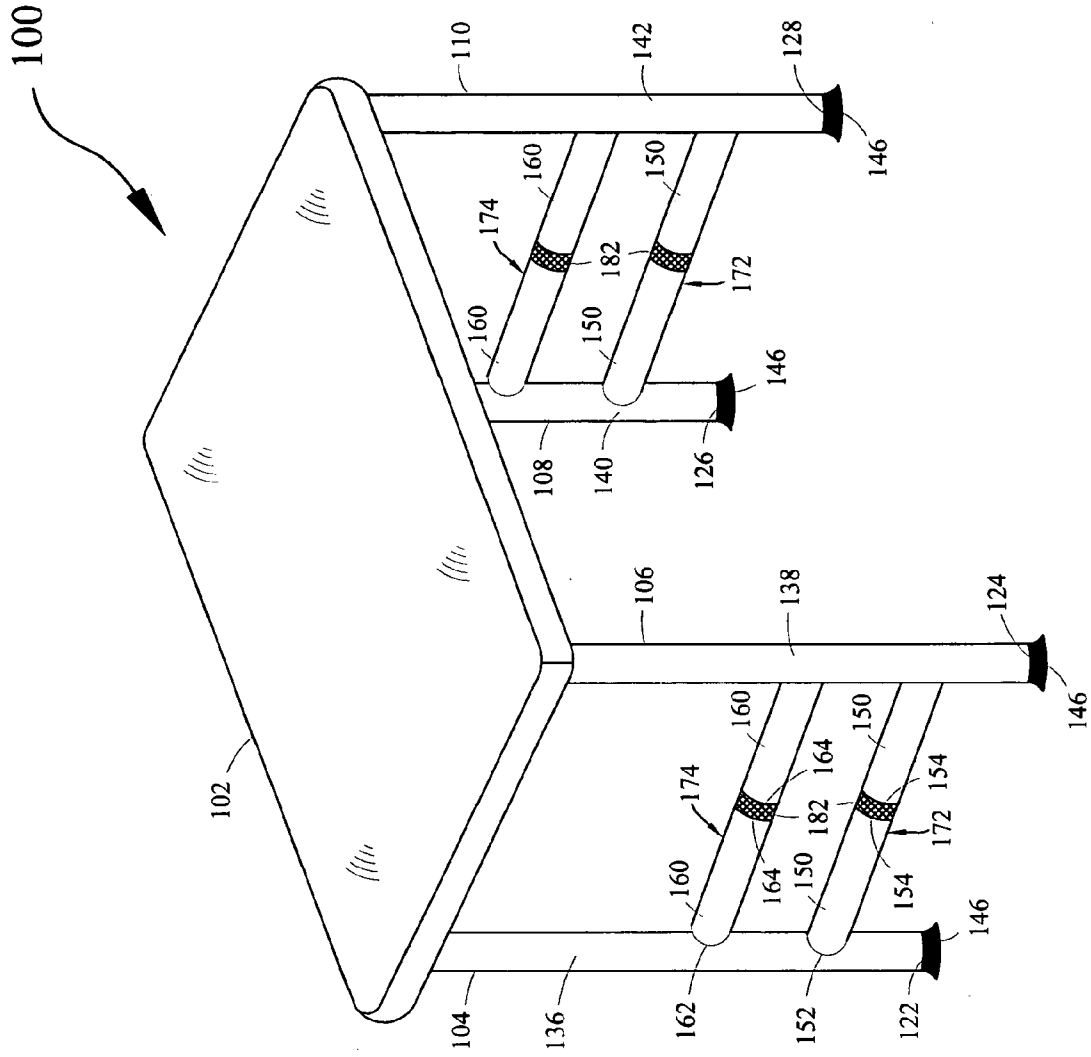

FIG. 1

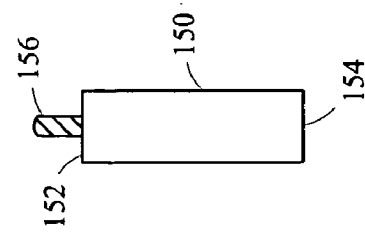
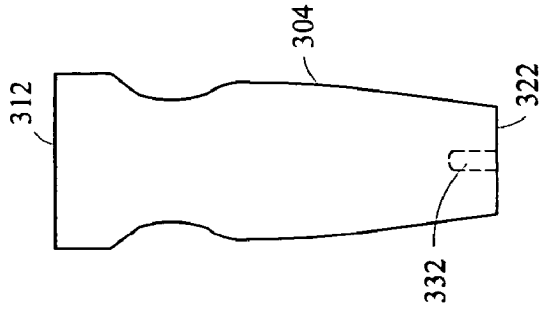

FIG. 2

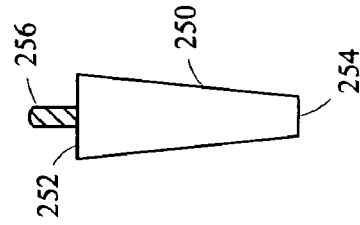
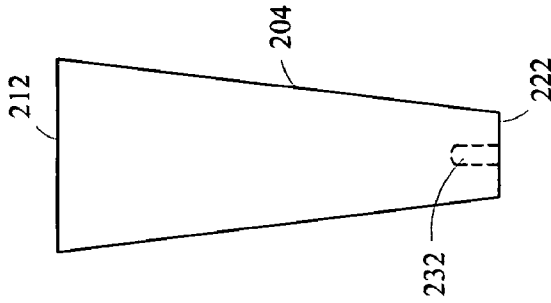

FIG. 3

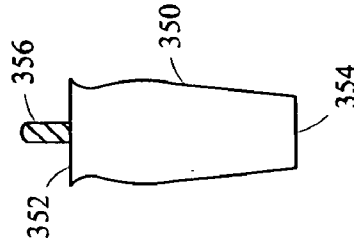
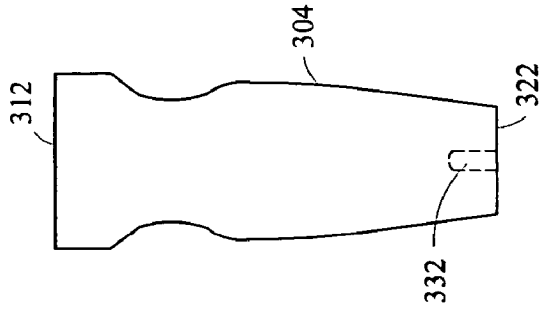

FIG. 4

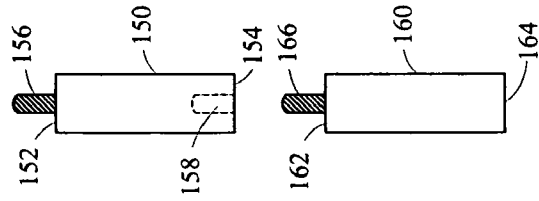
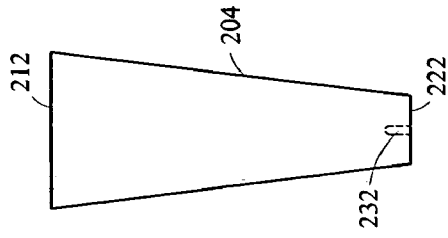

FIG. 5

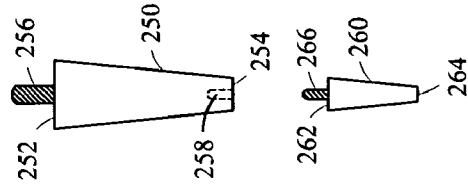
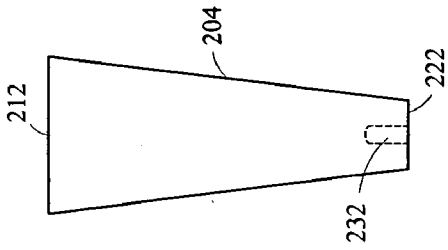

FIG. 6

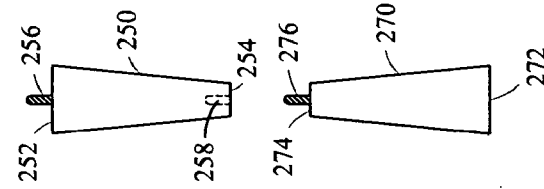
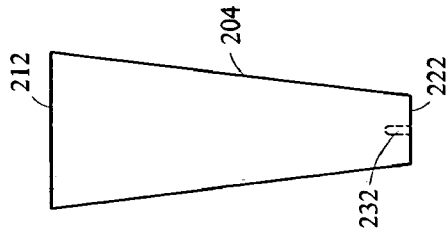

FIG. 7

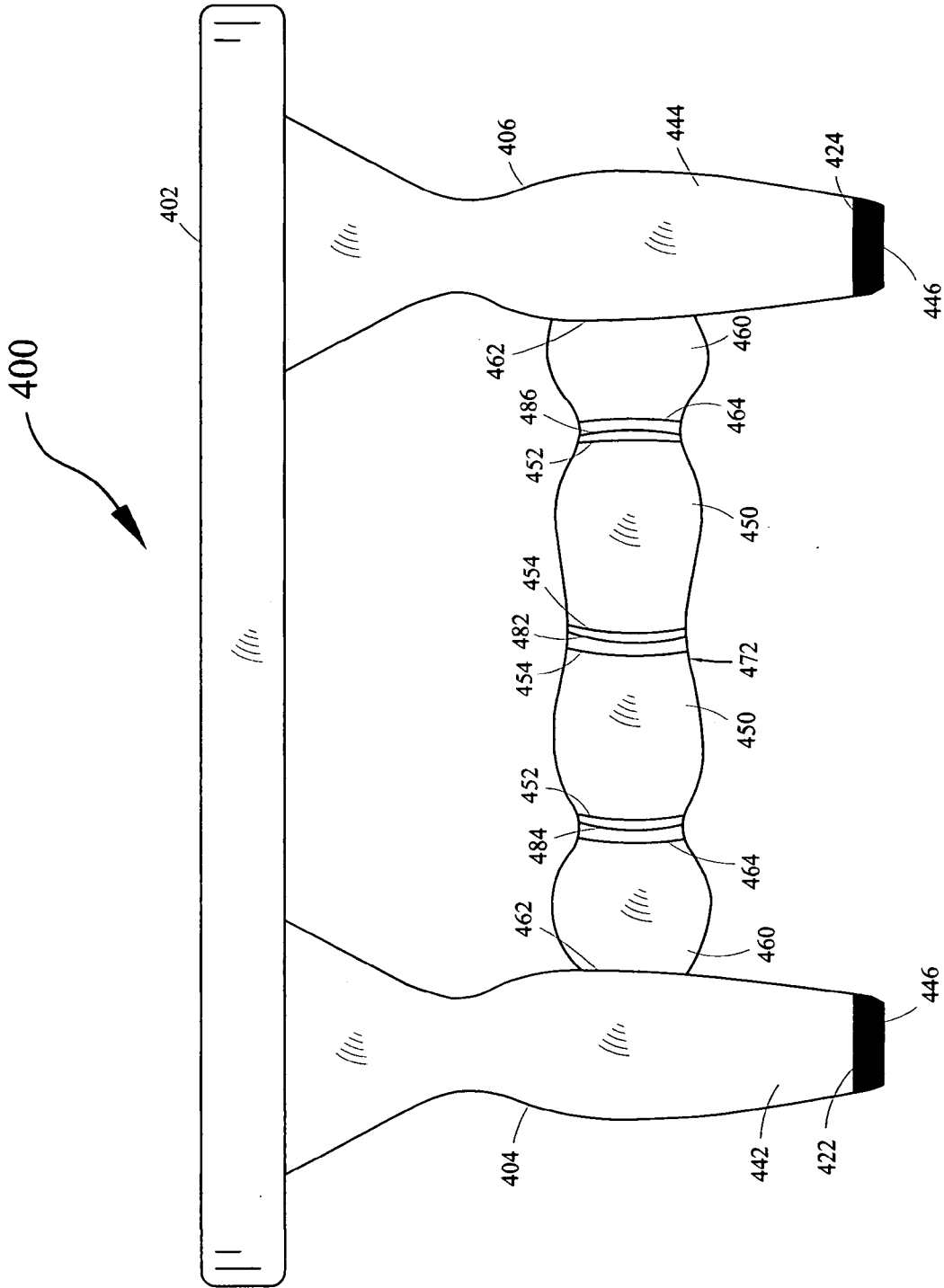

FIG. 8

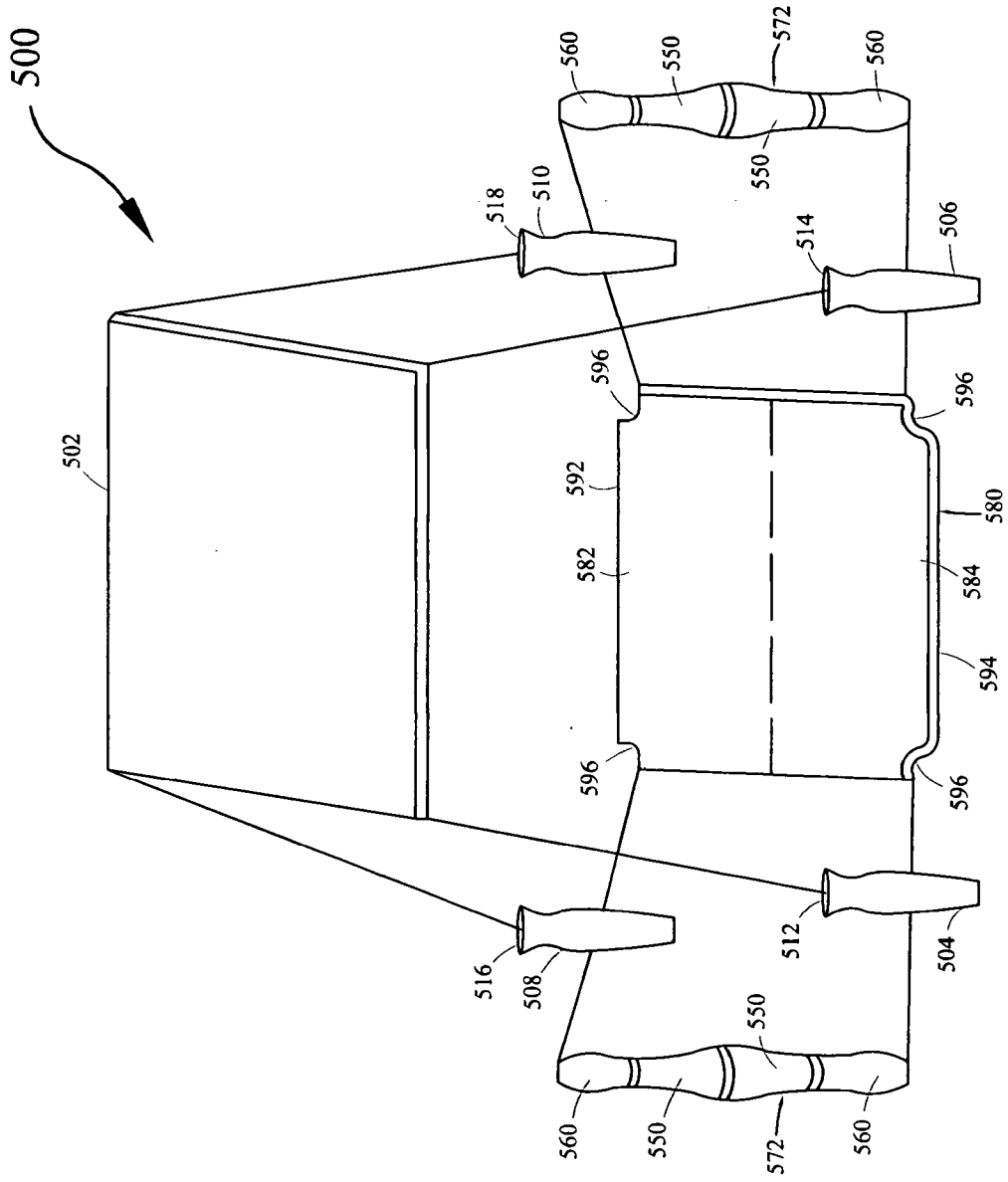

FIG. 9

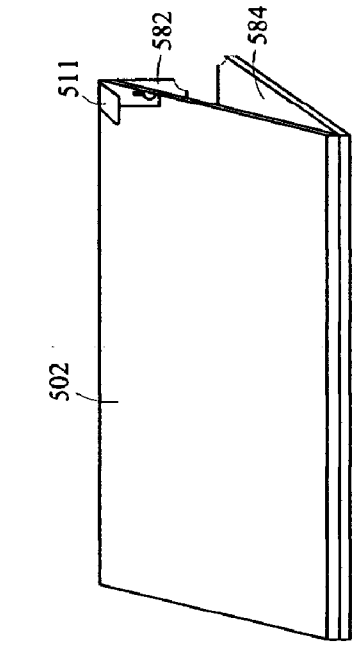

FIG. 10

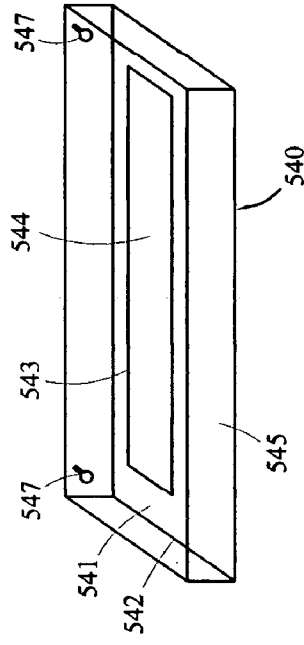

FIG. 11

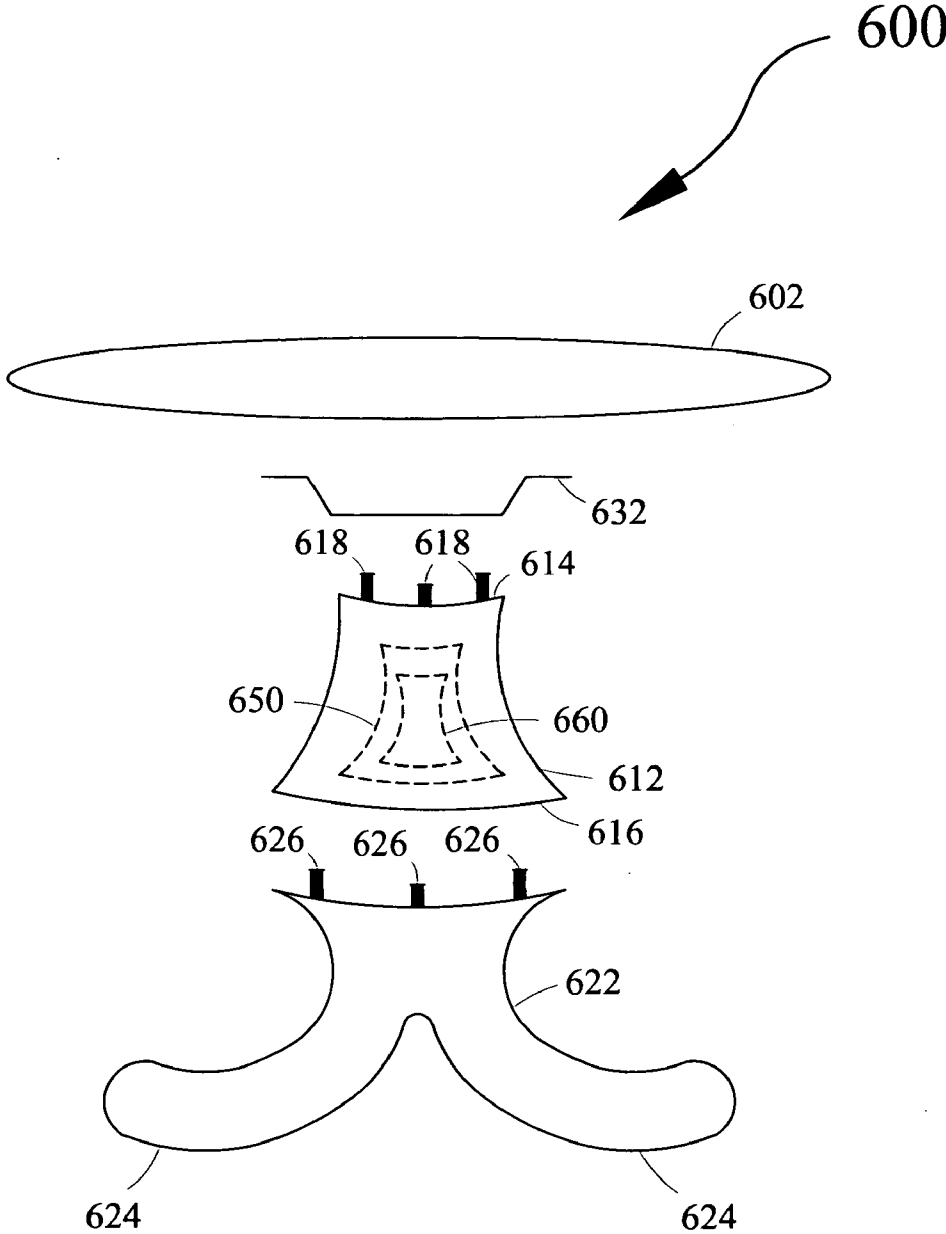

FIG. 12



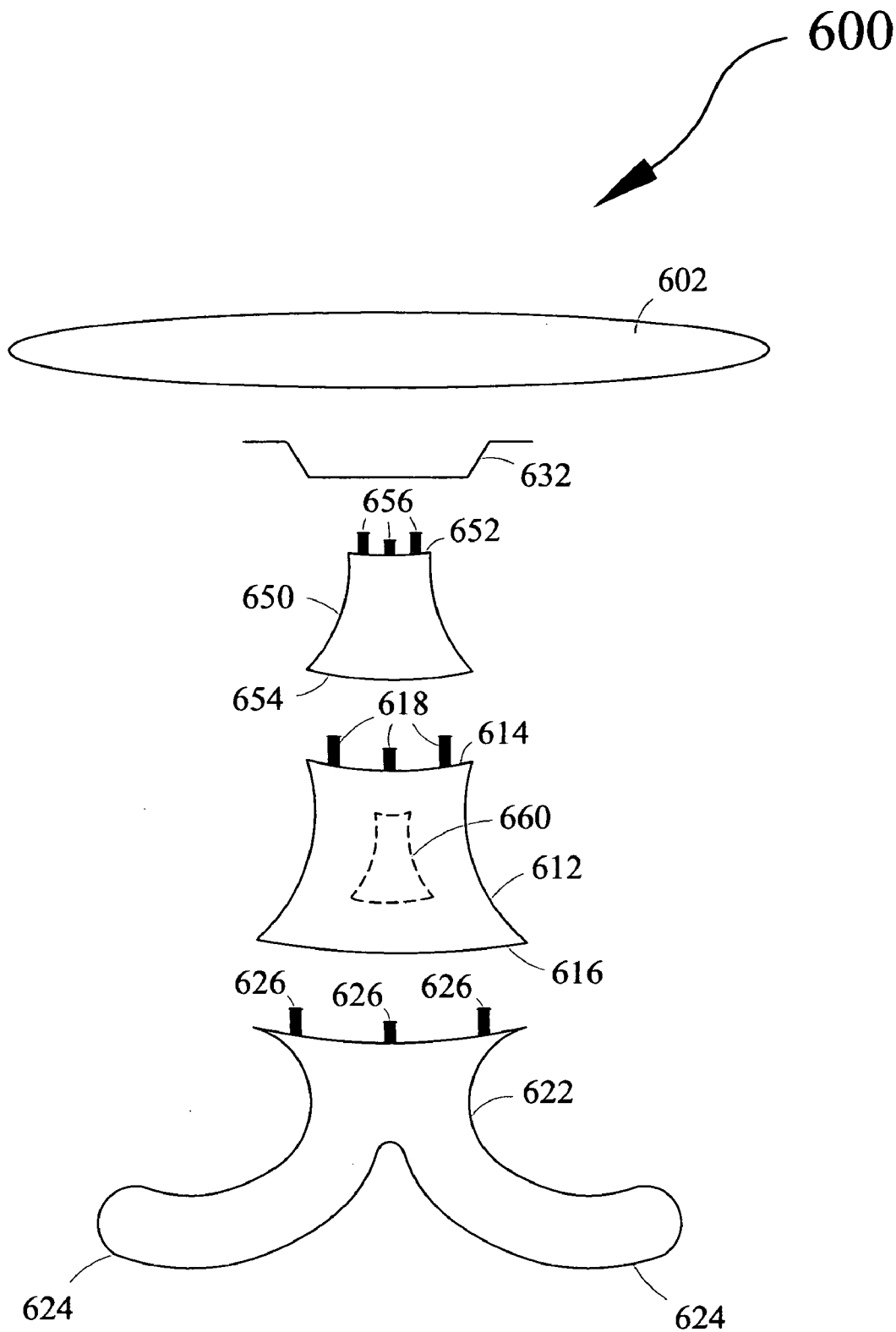

FIG. 13

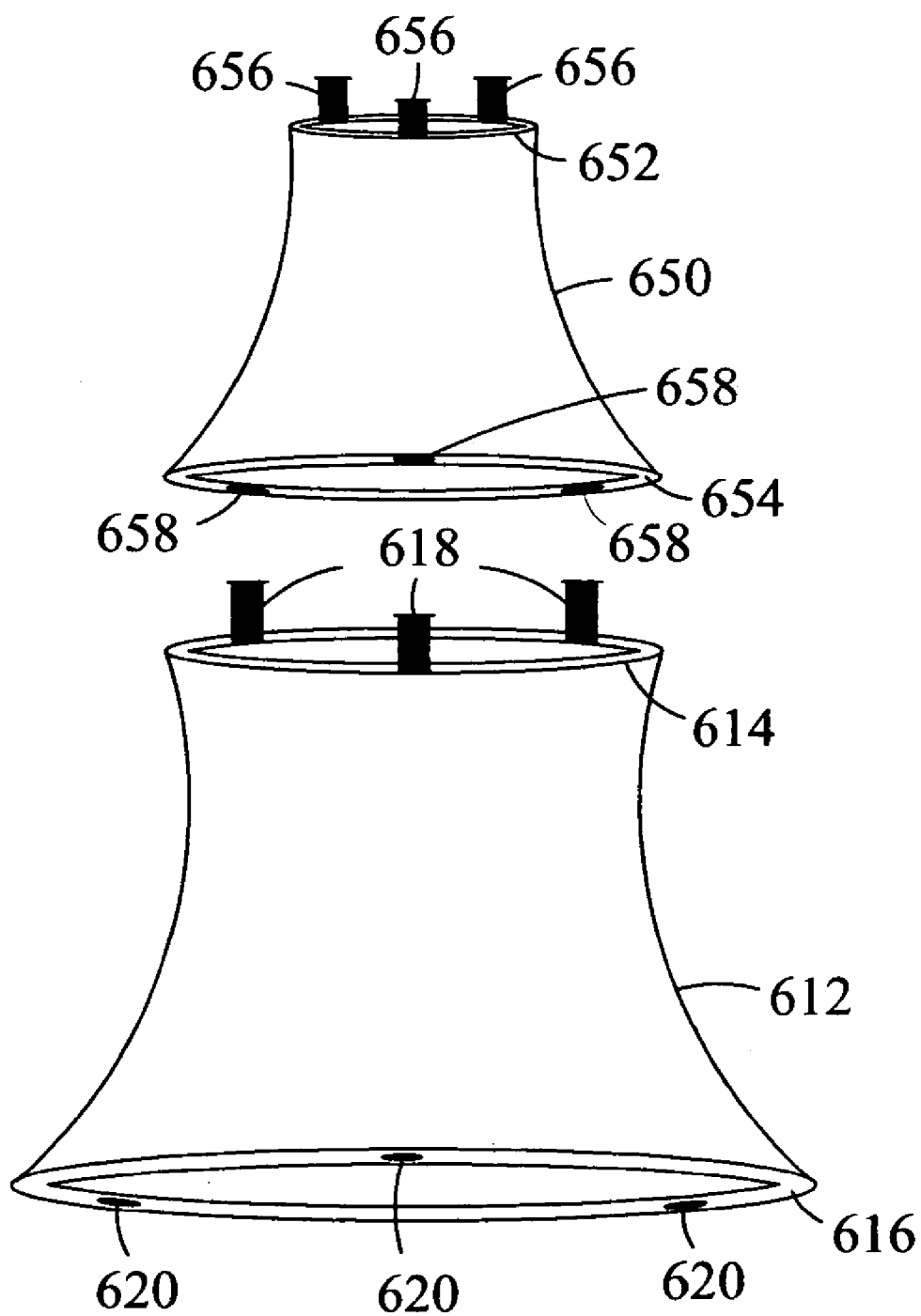

FIG. 14

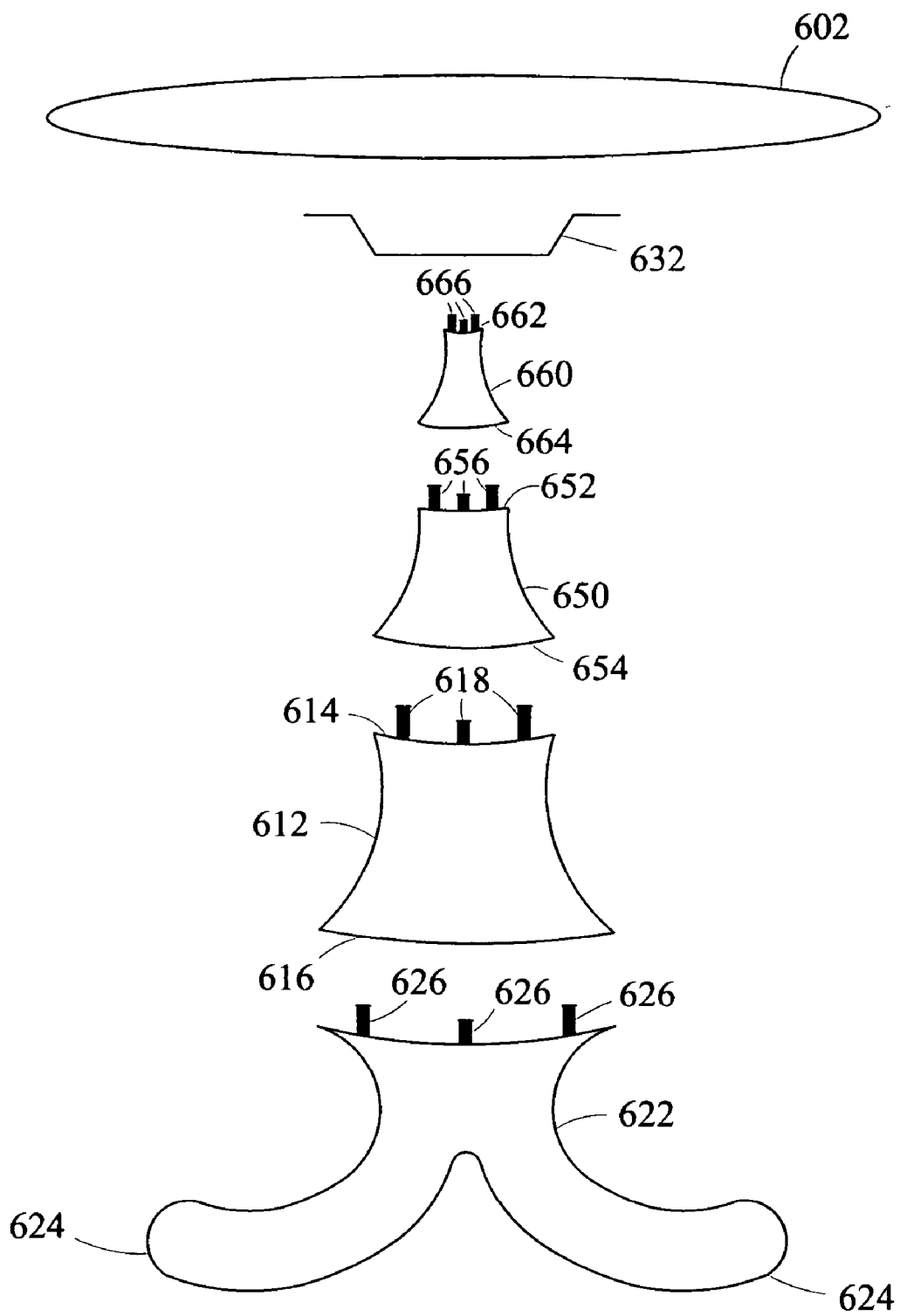

FIG. 15

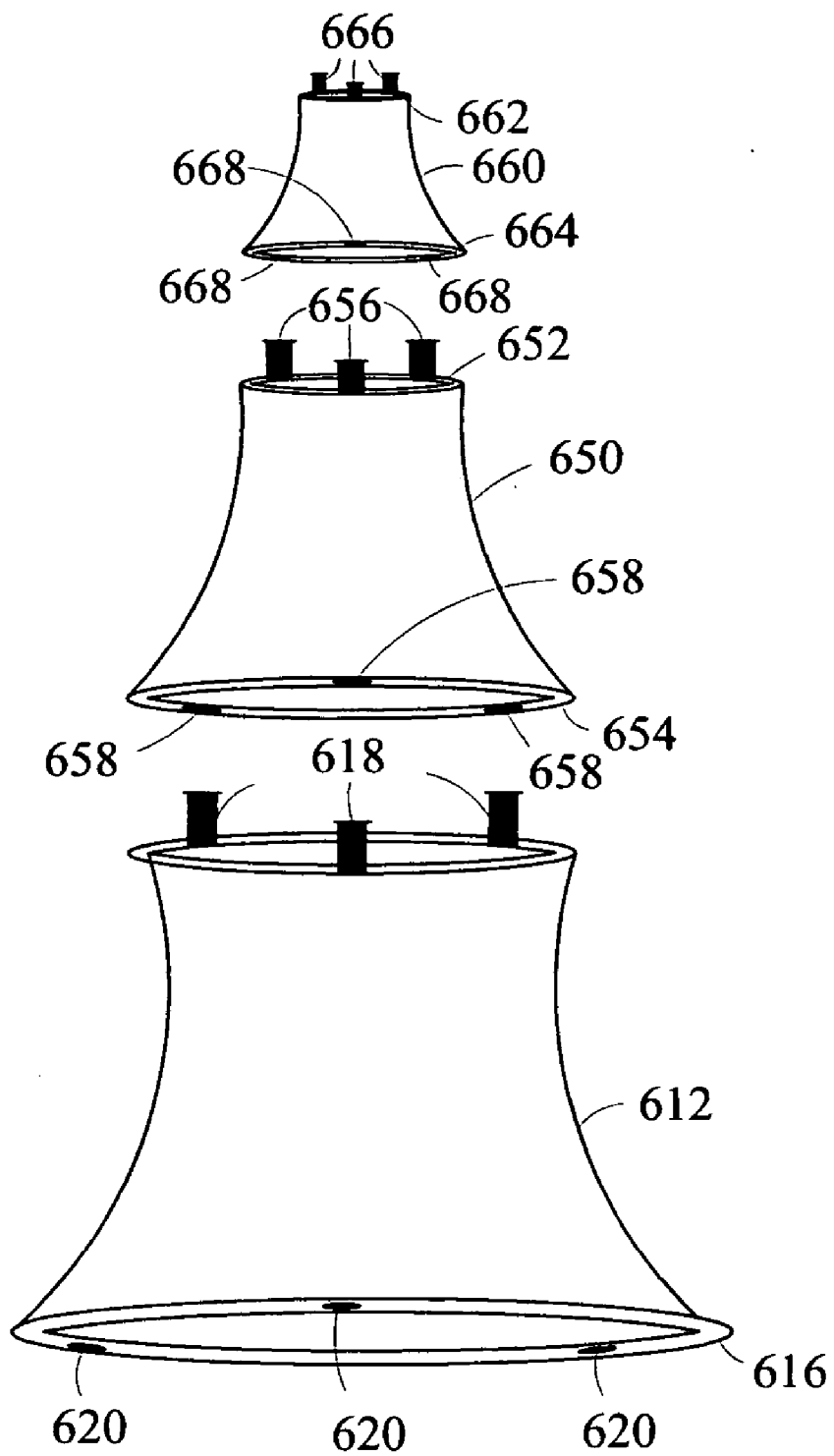

FIG. 16

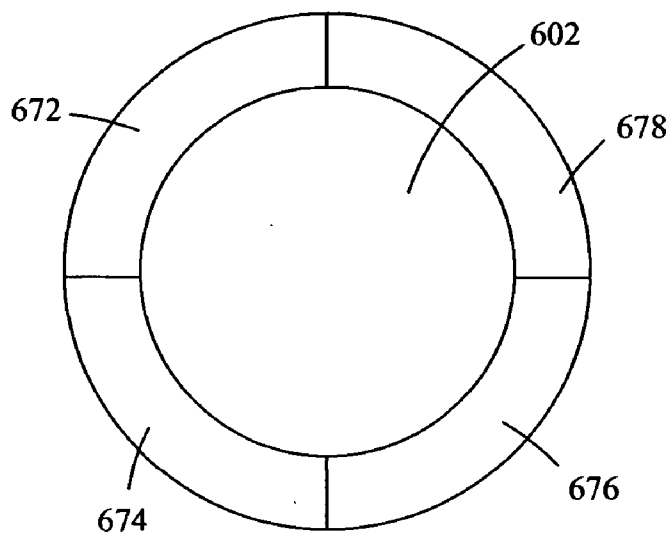

FIG. 17

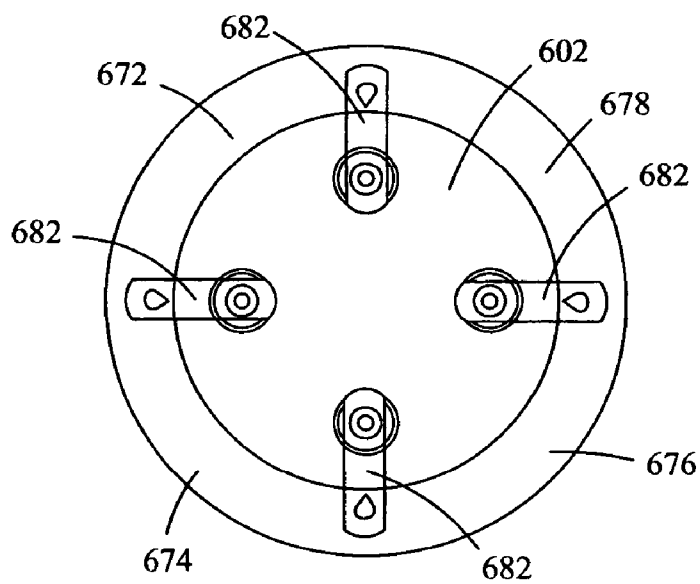

FIG. 18

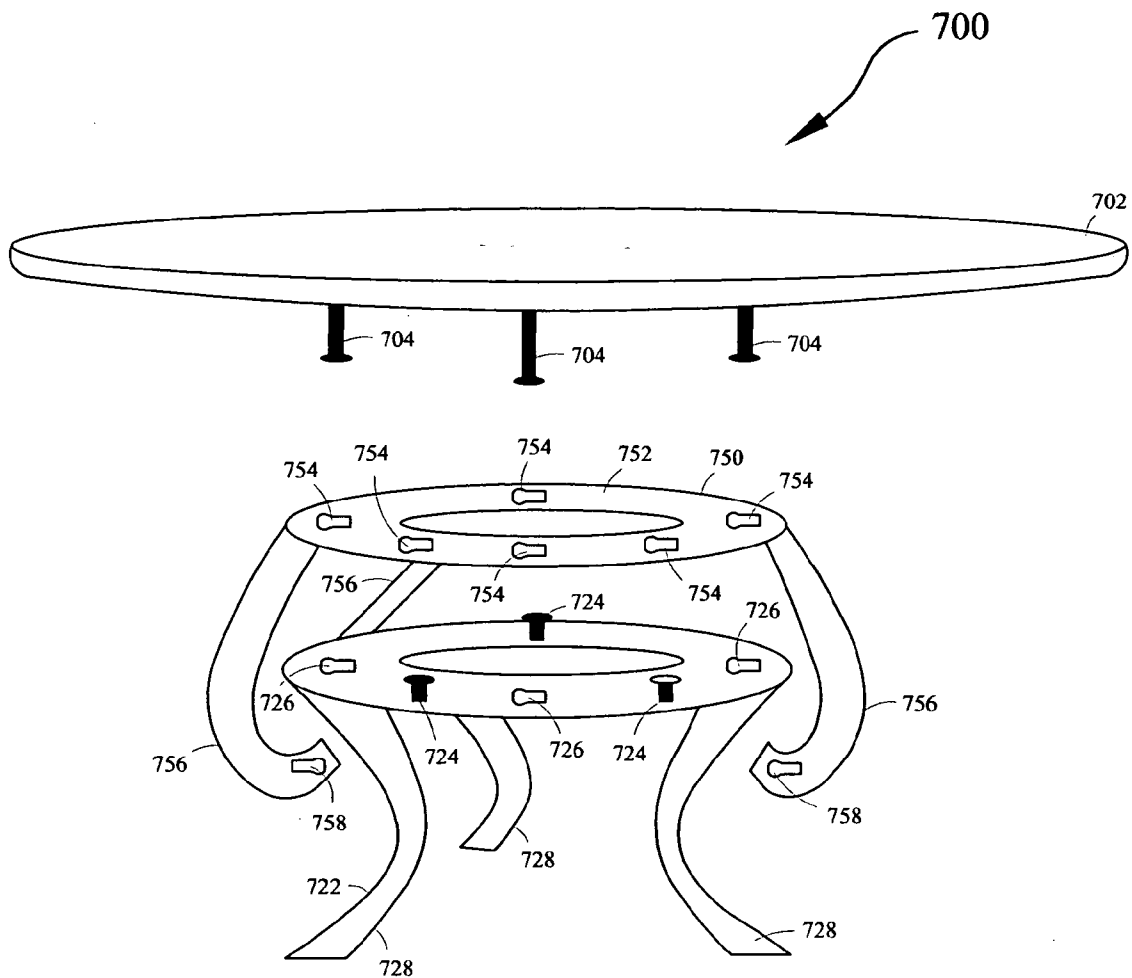

FIG. 19

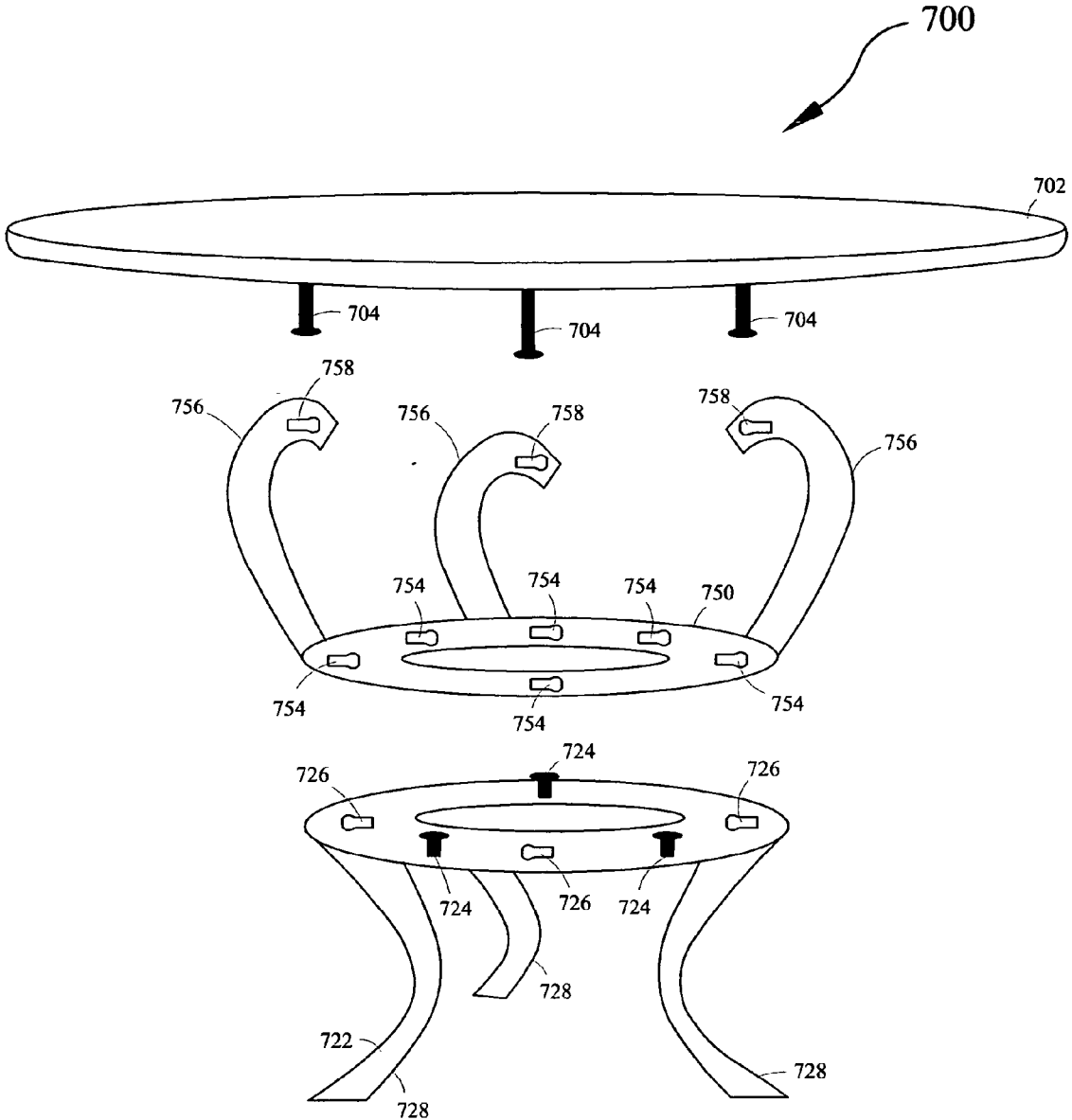

FIG. 20

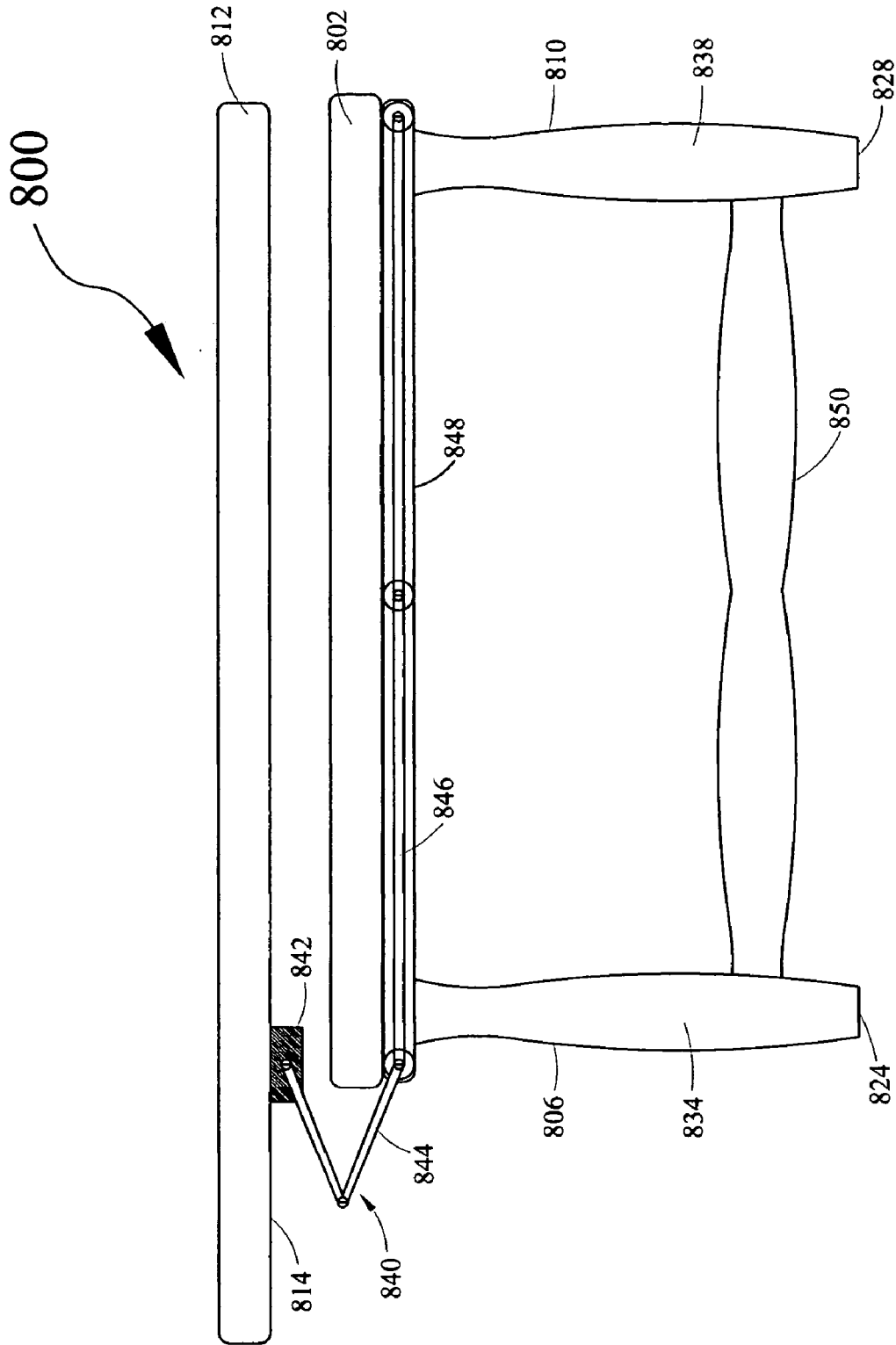

FIG. 21



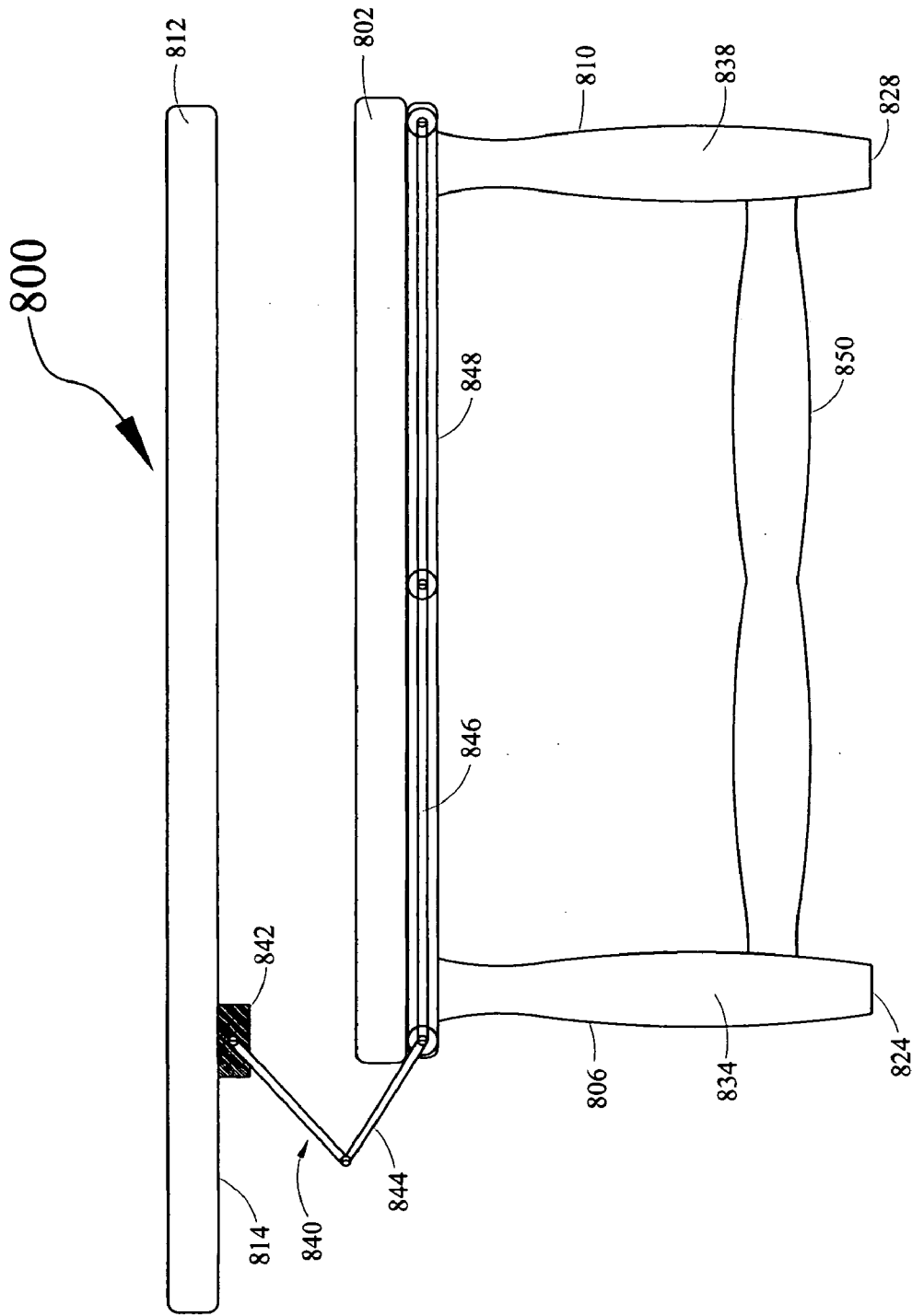

FIG. 22

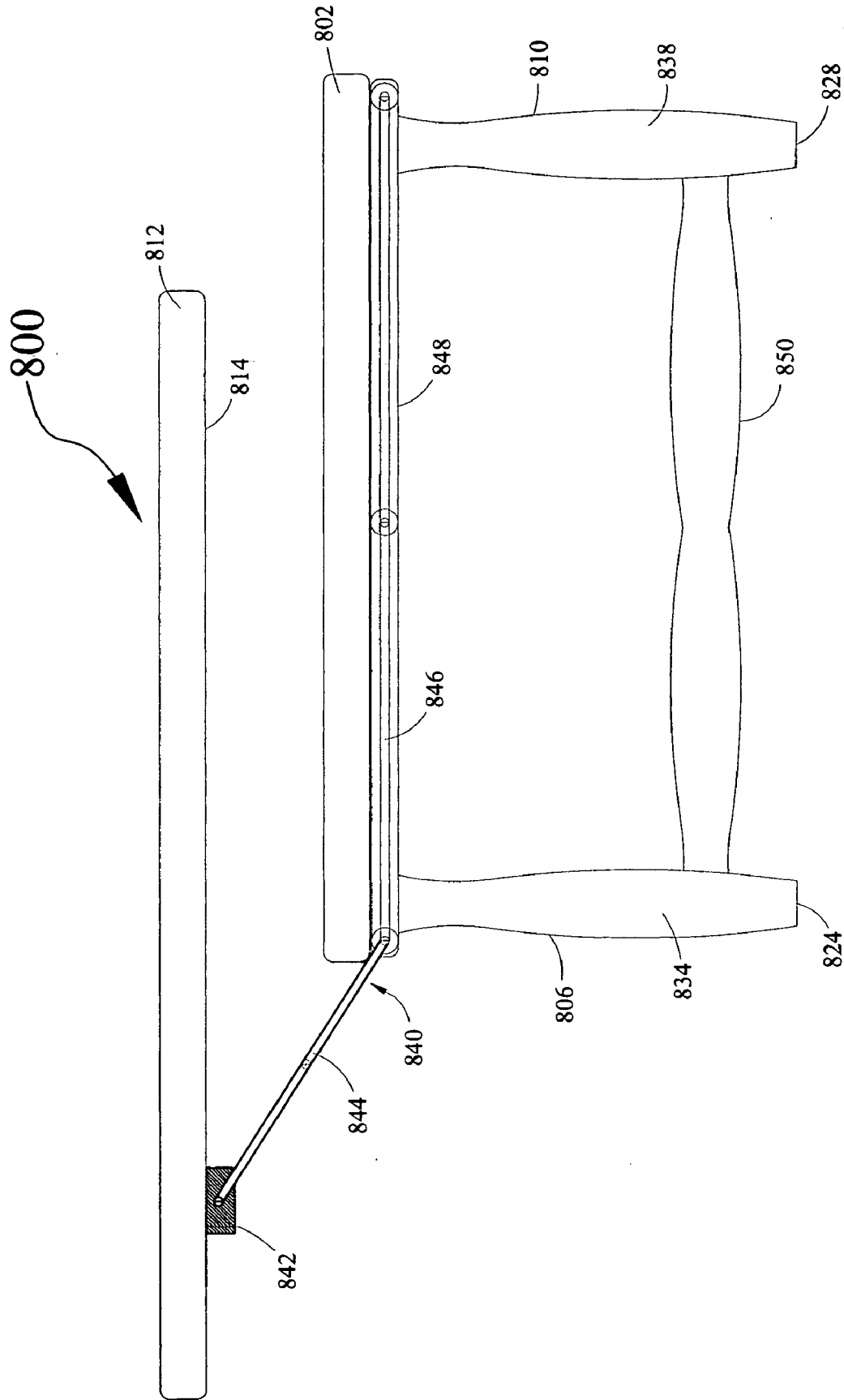

FIG. 23

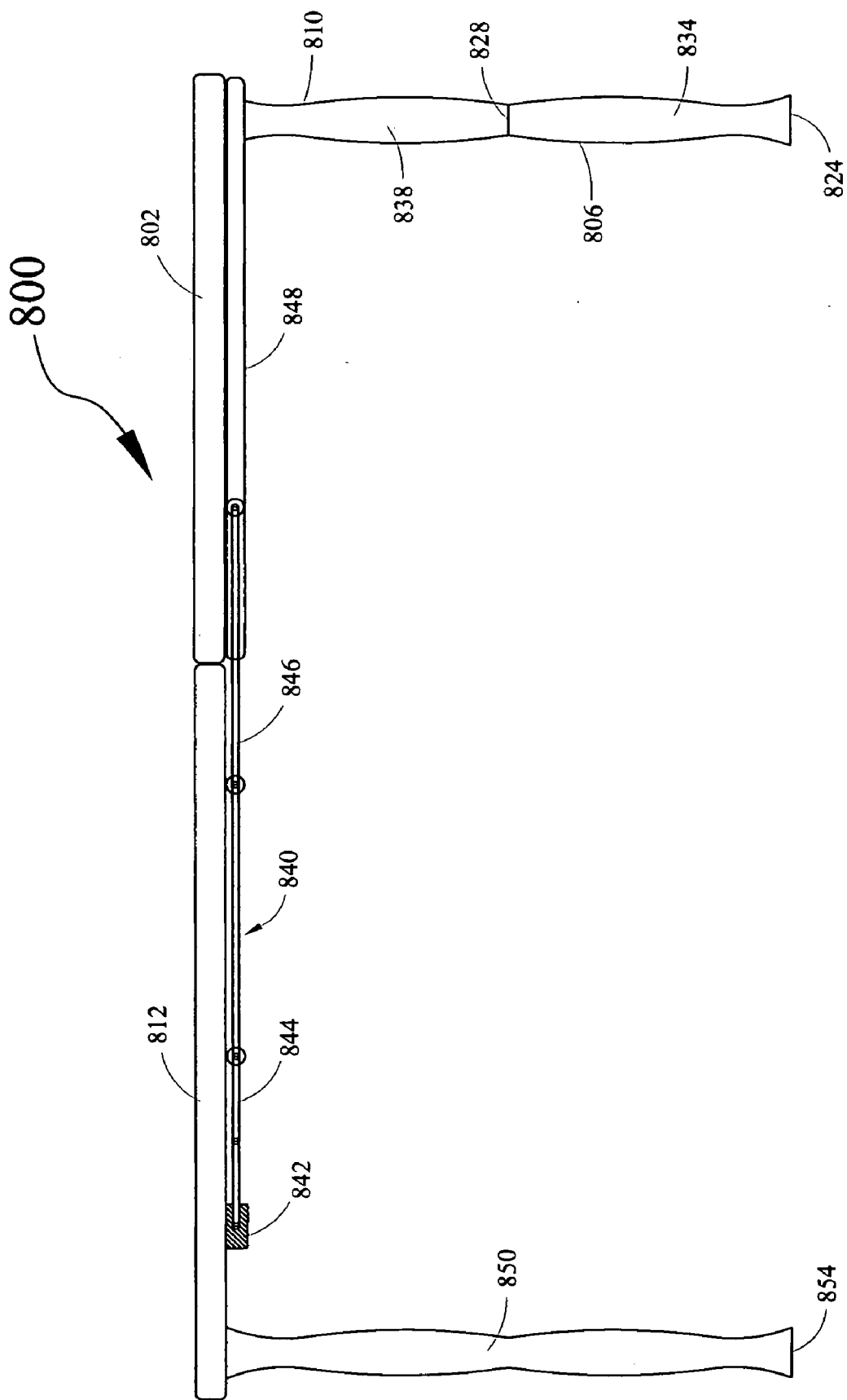

FIG. 24

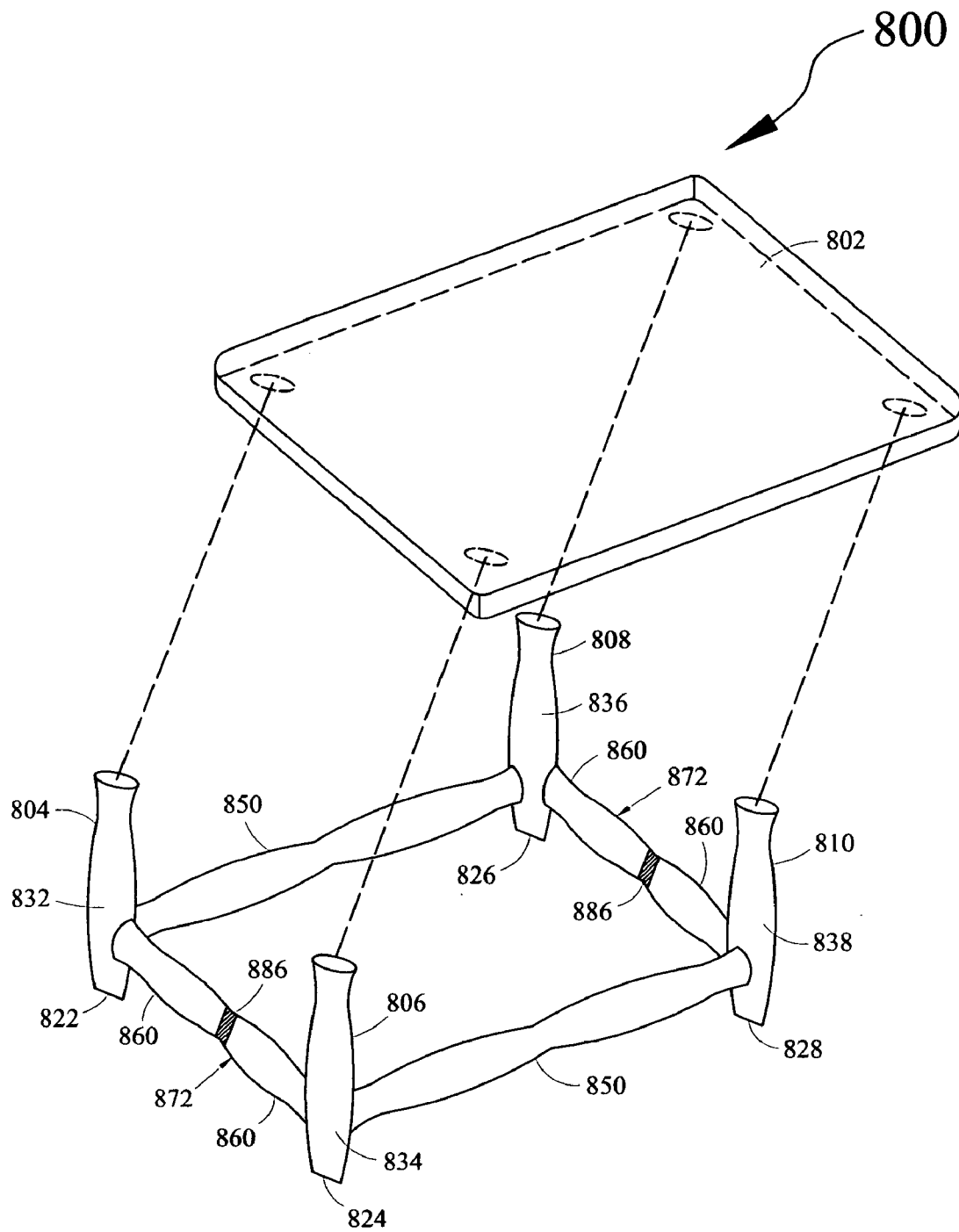

FIG. 25

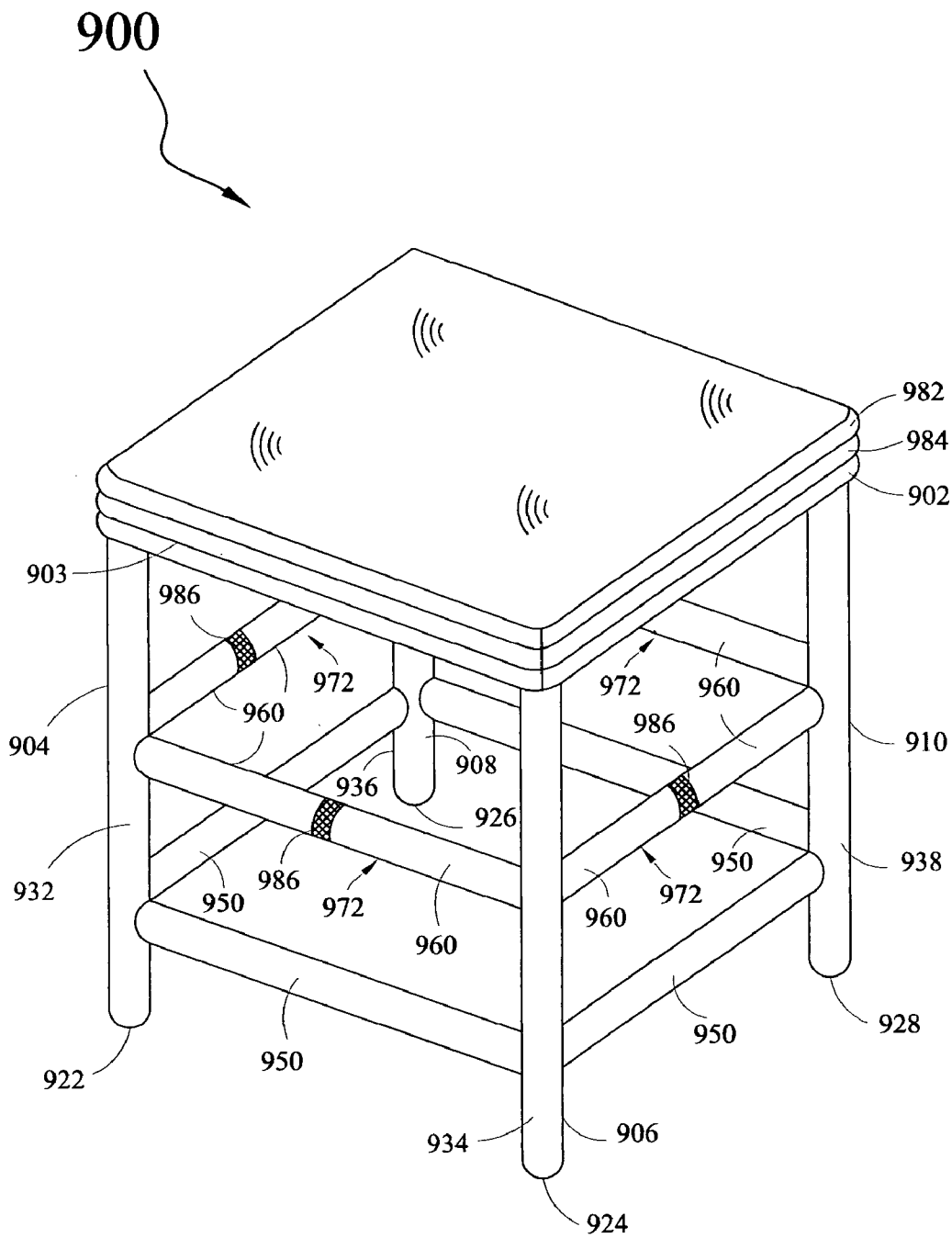

FIG. 26

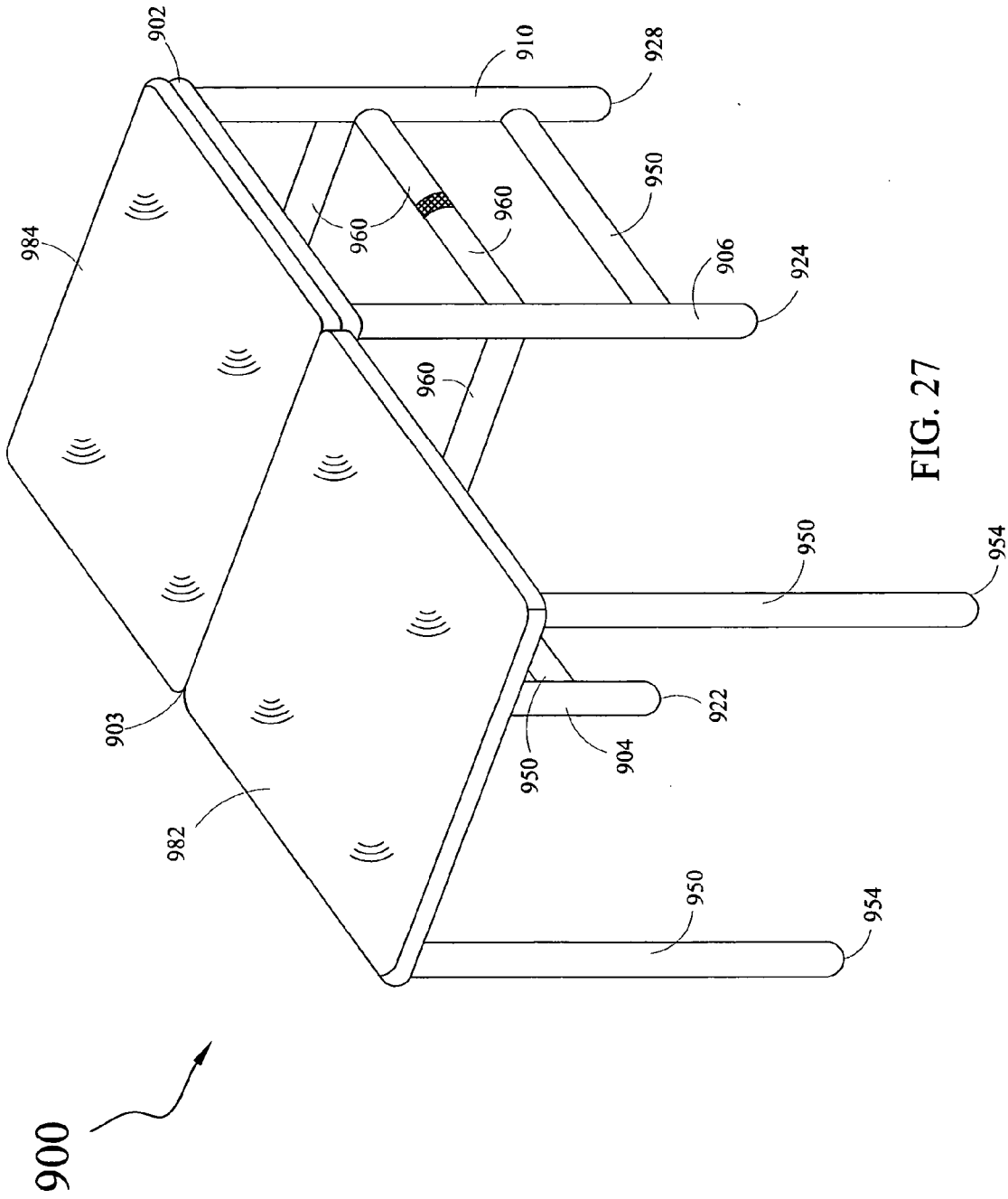

FIG. 27

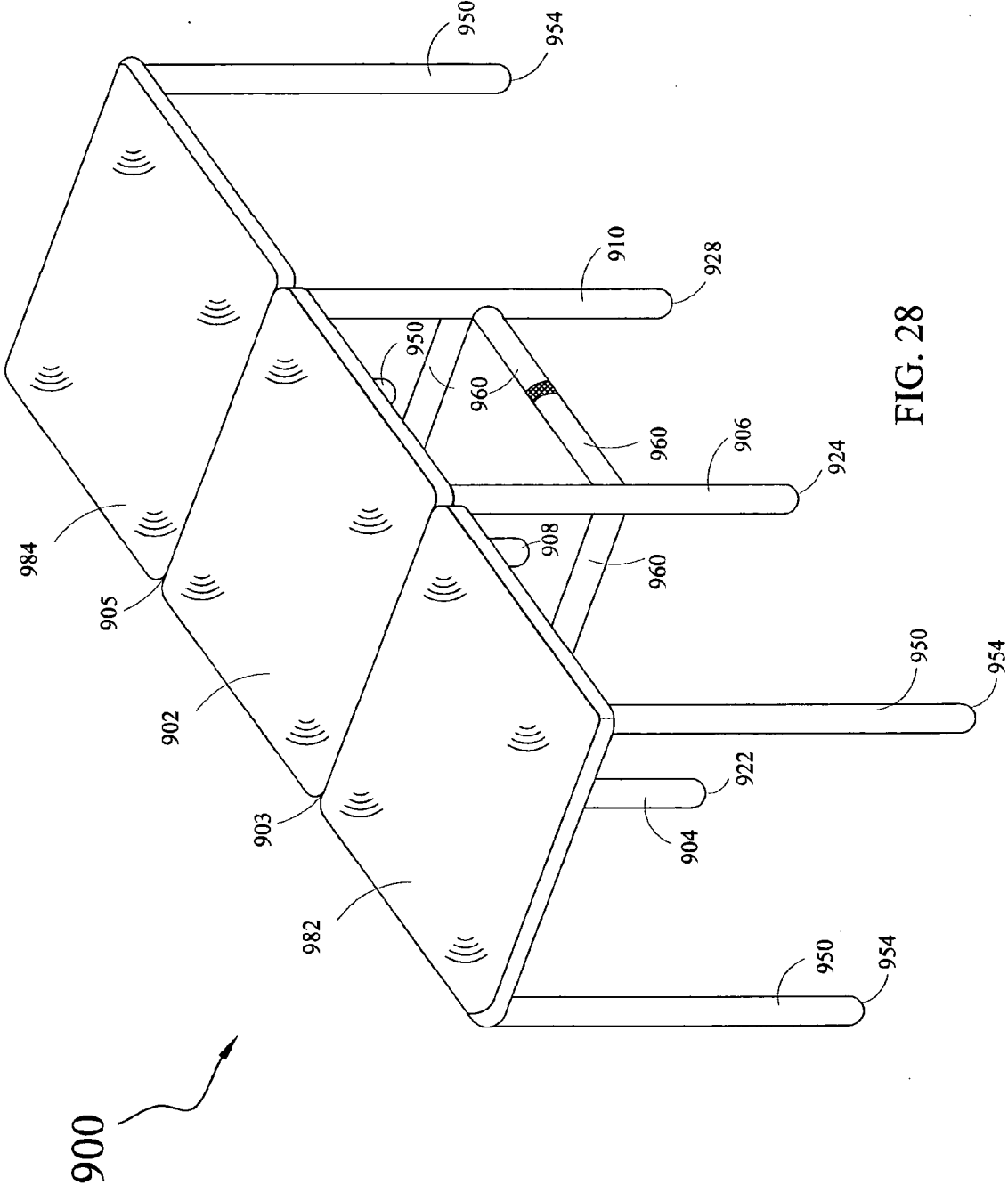

FIG. 28

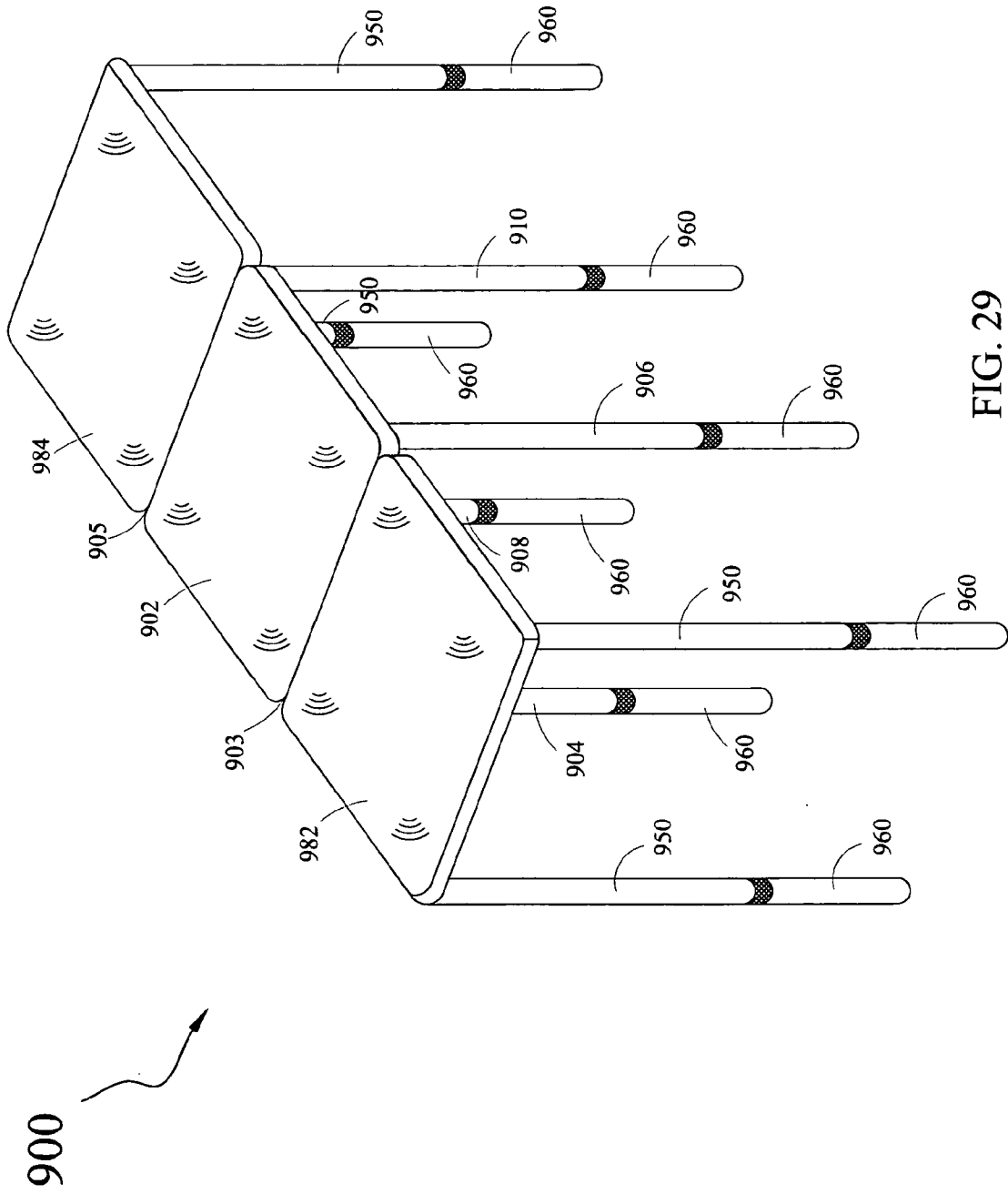

FIG. 29





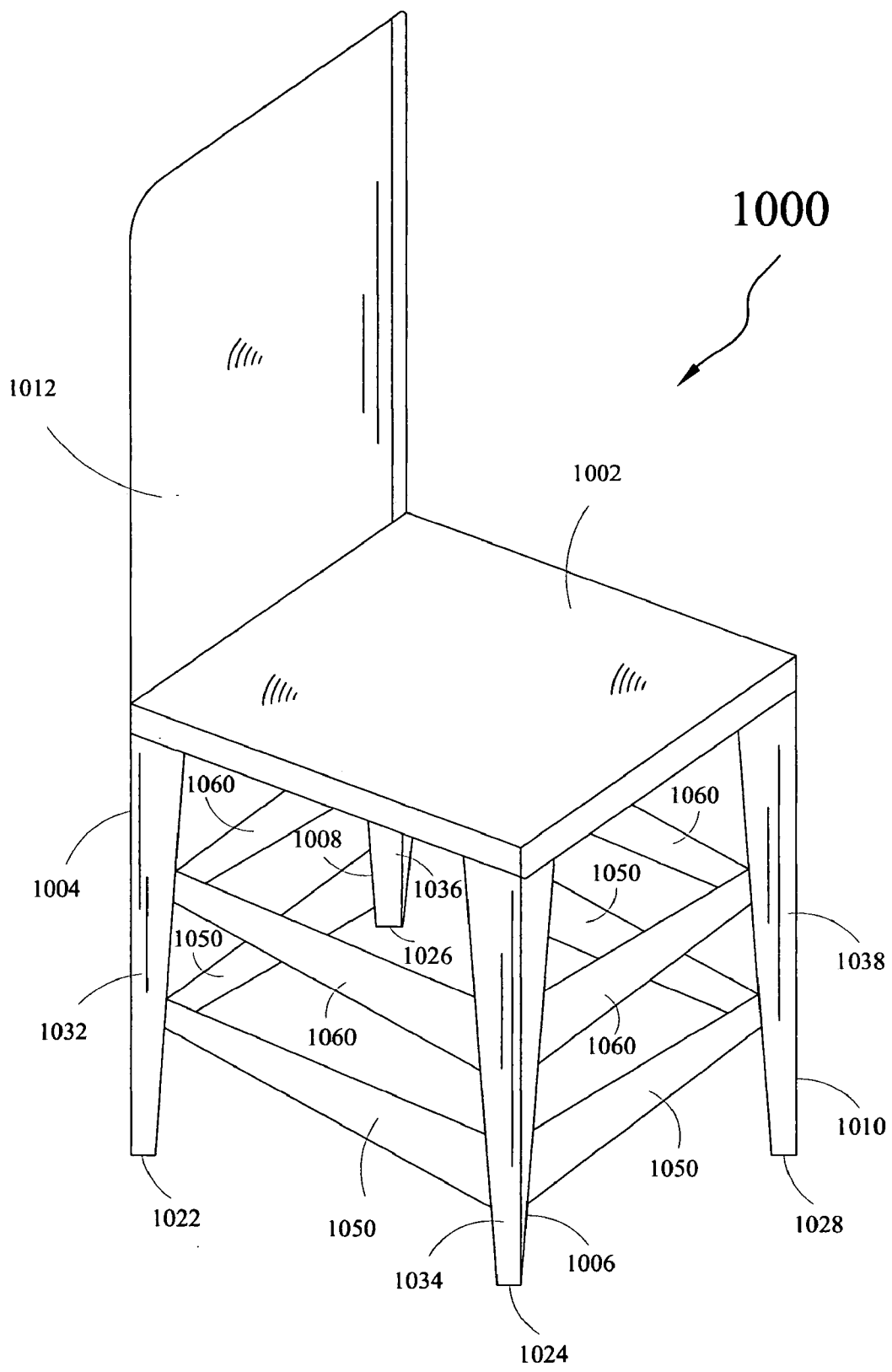

FIG. 31

**MULTI-PURPOSE VARIABLE HEIGHT TABLE AND CHAIRS**

**FIELD OF THE INVENTION**

[0001] The present invention relates to multi-purpose variable height tables and accompanying multi-purpose variable height chairs.

**BACKGROUND OF THE INVENTION**

[0002] Tables have been provided for various uses, and in case of those used for serving food, beverages, and the like, the tables differ in height above a floor or any other supporting surface. For example, a coffee table is of a much lower height than a pub table, while a dining table is of an intermediate height. Other tables include a counter height table that is generally of a lower height than a pub table, but higher than a dining table. Also, families having smaller children prefer lower height tables, while they may prefer an increased height table when the children grow up. Additionally, users may require tables with an increased overall size for those occasions when there are more guests.

[0003] Conventional tables have a fixed height and a fixed overall size, and users may end up keeping a plurality of differently sized tables (i.e., tables of different heights and different overall size) for serving different purposes. It may not be desirable to have more than one table since every additional table may occupy additional permanent floor space and contribute to additional expenses. Accordingly, it is convenient to have a table with height varying/adjusting features that vary/adjust the height of the table for serving different purposes. Also, it is convenient to have accompanying chairs with height varying/adjusting features to vary/adjust the height of the chairs.

[0004] Developments have been seen in the field of variable height tables. The prior art related to such development include the following:

[0005] U.S. Pat. No. 6,510,803 discloses a height adjustable table including a frame that has a pair of spaced apart, generally vertical frame sections, each supported upon a foot, a transverse, generally horizontal section that connects at its end portions to the vertical sections and a pair of lifts that are supported by the vertical frame sections to elevate between extended, higher elevational and retracted, lower elevational positions. The lifts support a table top with a work surface. The frame is in the form of a universal base that accepts a number of different mechanisms including, for example, a counterbalance mechanism, a motor drive mechanism, and a manually operable mechanism. These mechanisms can be selected by a user, depending upon the type of table that is to be manufactured. Such height adjustable tables use complicated and expensive mechanisms to vary the height of the table. Further, it does not provide features for increasing the overall size of the table.

[0006] U.S. Pat. No. 5,845,590 discloses an adjustable height table assembly consisting of a table top and an adjustable leg and base structure to which the table top is mounted. The leg and base structure includes a leg to which the table top is mounted, and a base to which the leg is mounted for vertical movement. The base includes a pair of vertical guide shafts, and a bearing assembly is secured to the leg and mounted to the guide shafts for providing vertical

movement of the leg relative to the base. An adjustment mechanism includes a lead screw extending through the leg and threadedly engaged with a lead nut secured to the base between the guide shafts, and a chain and sprocket system selectively imparts rotation to the lead screw upon manual operation of a crank. The adjustable height table uses a complicated and expensive height varying mechanism.

[0007] Accordingly, there remains a need for a table and accompanying chairs with height varying features for varying height of the table and the chairs in a fast, easy, convenient and inexpensive manner for serving different purposes. Also, what is needed is a table with features for increasing the overall size of the table.

**SUMMARY OF THE INVENTION**

[0008] In view of the foregoing disadvantages inherent in the prior arts, the general purpose of the present invention is to provide a multi-purpose variable height table and accompanying multi-purpose variable height chairs configured to include all the advantages of the prior art, and to overcome the drawbacks of the prior art.

[0009] In one aspect the present invention provides a multi-purpose variable height table-chair combination. The multi-purpose variable height table-chair combination comprises a variable height table having a table top, table legs supporting the table top, wherein the table top is engaged to top ends of the table legs, and at least one set of height varying adapters removably disposed between the table legs, the height varying adapters configured to raise a height of the variable height table when engaged to bottom ends of the table legs; at least one variable height chair having a seat, chair legs supporting the seat, and at least one set of height varying adapters disposed between the chair legs, the height varying adapters configured to raise a height of the variable height chair when engaged to bottom ends of the chair legs, corresponding to the raise in the height of the variable height table.

[0010] In another aspect, the present invention provides a variable height table, comprising a table top, at least one table leaf capable of being engaged with the table top to increase size of the table top, a table frame capable of housing the table top and the table leaf, table legs supporting the table frame, wherein the table frame is engaged to top ends of the table legs and at least one set of height varying adapters disposed between the table legs, the height varying adapters capable of being engaged to bottom ends of the table legs for raising the height of the variable height table, when removed from between the table legs.

[0011] In yet another aspect, the present invention provides a variable height table, comprising a table top, at least one pedestal supporting the table top, at least one set of height varying adapters housed in the pedestal, the height varying adapters capable of being engageably disposed between the pedestal and the table top for raising a height of the variable height table, when removed from within the pedestal.

[0012] These together with other aspects of the present invention, along with the various features of novelty that characterize the invention, are pointed out with particularity in the claims annexed hereto and forming a part of this disclosure. For a better understanding of the invention, its

operating advantages and the specific objects attained by its uses, reference should be had to the accompanying drawings and descriptive matter in which there are illustrated exemplary embodiments of the present invention.

#### BRIEF DESCRIPTION OF THE DRAWINGS

[0013] The advantages and features of the present invention will become better understood with reference to the following more detailed description and claims taken in conjunction with the accompanying drawings, wherein like elements are identified with like symbols, and in which:

[0014] FIG. 1 is a perspective view of a variable height table 100, according to an exemplary embodiment of the present invention;

[0015] FIG. 2 is an exploded component view of a height varying adapter 150, engaged to a table leg 104, according to an exemplary embodiment of the present invention;

[0016] FIG. 3 is an exploded component view of a height varying adapter 250, engaged to a table leg 204, according to an exemplary embodiment of the present invention;

[0017] FIG. 4 is an exploded component view of a height varying adapter 350, engaged to a table leg 304, according to an exemplary embodiment of the present invention;

[0018] FIG. 5 is an exploded component view of two height varying adapters 150, 160, engaged to a table leg 104, according to an exemplary embodiment of the present invention;

[0019] FIG. 6 is an exploded component view of two height varying adapters 250, 260, engaged to a table leg 204, according to an exemplary embodiment of the present invention;

[0020] FIG. 7 is an exploded component view of two height varying adapters 250, 270, engaged to a table leg 204, according to an exemplary embodiment of the present invention;

[0021] FIG. 8 is a side view of a variable height table 400, according to an exemplary embodiment of the present invention;

[0022] FIG. 9 is an exploded perspective view of a variable height table 500 with a two-piece shelf 580, according to an exemplary embodiment of the present invention;

[0023] FIG. 10 is an exploded top view of table leaves 582, 584 engaged to a table top 502, according to an exemplary embodiment of the present invention;

[0024] FIG. 11 is an exploded perspective view of the table top 502 and the table leaves 582, 584 housed in a table frame 540, according to an exemplary embodiment of the present invention;

[0025] FIG. 12 is an exploded side view of a pedestal-style variable height table 600, according to an exemplary embodiment of the present invention;

[0026] FIG. 13 is a side view of the pedestal-style variable height table 600 with height varying adapter 650 disposed between the pedestal 612 and a table top 602, according to an exemplary embodiment of the present invention;

[0027] FIG. 14 is an exploded component view illustrating the engagement between pedestal 612 and the height varying adapter 650, according to an exemplary embodiment of the present invention;

[0028] FIG. 15 is a side view of the pedestal-style variable height table 600 with height varying adapters 650, 660 disposed between the pedestal 612 and a table top 602, according to an exemplary embodiment of the present invention;

[0029] FIG. 16 is an exploded component view illustrating the engagement between pedestal 612 and the height varying adapters 650, 660, according to an exemplary embodiment of the present invention;

[0030] FIG. 17 is a top view the table top 602 with engaged table leaves 672, 674, 676, 678, according to an exemplary embodiment of the present invention;

[0031] FIG. 18 is a bottom view of the table top with engaged table leaves 672, 674, 676, 678, according to an exemplary embodiment of the present invention;

[0032] FIG. 19 is an exploded perspective view of a variable height table 700 with an ornamental center support 750, according to an exemplary embodiment of the present invention;

[0033] FIG. 20 is an exploded perspective view of a variable height table 700 with the ornamental center support 750 in a flipped over orientation, according to an exemplary embodiment of the present invention; and

[0034] FIG. 21 is a side view of a variable height table 800 with a second table top 812 in a 'top-down' position, according to an exemplary embodiment of the present invention;

[0035] FIG. 22 is a side view of the variable height table 800 with the second table top 812 in a 'top-up' position, according to an exemplary embodiment of the present invention;

[0036] FIG. 23 is a side view of the variable height table 800 with the second table top 812 in an intermediate position, according to an exemplary embodiment of the present invention;

[0037] FIG. 24 is a side view of the variable height table 800 with the second table top 812 in a 'side' position, according to an exemplary embodiment of the present invention;

[0038] FIG. 25 is an exploded perspective view of the variable height table 800, according to an exemplary embodiment of the present invention;

[0039] FIG. 26 is a perspective view of an end-table 900, according to an exemplary embodiment of the present invention;

[0040] FIG. 27 is a perspective view of the end-table 900 with a table leaf 982 in an 'open' position, according to an exemplary embodiment of the present invention;

[0041] FIG. 28 is a perspective view of the end-table 900 with the table leaves 982, 984 in an 'open' position, according to an exemplary embodiment of the present invention;

[0042] FIG. 29 is a perspective view of the end-table 900 in a raised position, according to an exemplary embodiment of the present invention;

[0043] FIG. 30 is a perspective view of the end-table 900 converted to a chair, according to an exemplary embodiment of the present invention; and

[0044] FIG. 31 is a perspective view of a variable height chair 1000, according to an exemplary embodiment of the present invention.

[0045] Like reference numerals refer to like parts throughout the description of several views of the drawings.

#### DETAILED DESCRIPTION OF THE INVENTION

[0046] The exemplary embodiments described herein detail for illustrative purposes are subject to many variations in structure and design. It should be emphasized, however that the present invention is not limited to a particular variable height table and accompanying variable height chairs, as shown and described. It is understood that various omissions, substitutions of equivalents are contemplated as circumstances may suggest or render expedient, but is intended to cover the application or implementation without departing from the spirit or scope of the claims of the present invention.

[0047] The terms “first,” “second,” and the like, herein do not denote any order, quantity, or importance, but rather are used to distinguish one element from another, and the terms “a” and “an” herein do not denote a limitation of quantity, but rather denote the presence of at least one of the referenced item.

[0048] The present invention provides a multi-purpose variable height table (referred herein as “variable height table”) with height varying adapters for varying height of the variable height table in a fast, easy, convenient and inexpensive manner for serving different purposes. The variable height table comprises a table top, and table legs supporting the table top. The table top is engaged to top ends of the table legs. The variable height table further comprises at least one set of height varying adapters that can be engaged to bottom ends of the table legs for raising a height of the variable height tables. The height varying adapters may be disengaged from the bottom ends of the table legs for lowering back the height of variable height tables. Also, the variable height table has features for increasing the overall size of the variable height table. The present invention further provides multi-purpose variable height chairs (referred herein as “variable height chairs”) with height varying adapters disposed between chair legs that can be used in combination with such variable height tables. The variable height table and the accompanying variable height chairs are constructed in such a manner that the stability and structural support of the variable height table and chairs do not always depend on the height varying adapters.

[0049] The variable height table can serve as a multiple use table and replaces the need for plurality of differently sized tables (i.e., tables of different heights and different overall size). In one embodiment, the variable height table can serve as: a coffee table without any height varying adapters engaged to the bottom end of the table legs; a dining table on raising the height of the variable height table

using a first set of height varying adapters; a counter height table on raising the height of the variable height table using a second set of height varying adapters in addition to the first set of height varying adapters; and a pub table on raising the height of the variable height table using a third set of height varying adapters in addition to the first and second set of height varying adapters. Such a variable height table and accompanying variable height chairs provide a suitable multi-purpose variable height table-chair combination, aiding furniture manufacturers for not having to produce or to stock the differently sized tables, chairs, and bar stools.

[0050] Referring to FIGS. 1-7 a variable height table 100 comprises a substantially rectangular table top 102 and four table legs 104, 106, 108, 110 supporting the table top 102. Other possible shapes for the table top 102 include, but are not limited to, square, other polygonal shapes, oval, and other rounded shapes. The table top 102 is engaged to top ends (not shown) of the table legs 104, 106, 108, 110. Although FIG. 1 shows the table legs 104, 106, 108, 110 having a cylindrical shape, the table legs 104, 106, 108, 110 can take any other desired shape that provides sufficient support to the table top 102 and sufficient stability to the variable height table 100. The variable height table 100 further comprises height varying adapters 150, 160 that are disposed in sets of two height varying adapters 150 forming cross bars 172, and in sets of two height varying adapters 160 forming cross bars 174. The cross bars 172, 174 extend laterally between the table legs 104 and 106 and between the table legs 108 and 110. The disposal of the height varying adapters 150, 160 as cross bars is not limited to sets of two height varying adapters 150, 160 as cross bars. In another embodiment, the height varying adapters 150, 160 are disposed in sets of four height varying adapters 150, 160 forming cross bars.

[0051] For purposes of description, taking one of the cross bars 172, i.e., two height varying adapters 150 disposed between the table legs 104 and 106. The two height varying adapters 150 may be engaged to each other at second ends 154 of the height varying adapters 150, and engaged to main surface 136, 138 of the table legs 104 and 106 at first ends 152 of the height varying adapters 150. In one embodiment, the two height varying adapters 150 are engaged to each other at second ends 154 using engagement means in the form of a knurl 182 with a spring (not shown) pushing outwards to hold the height varying adapters 150 in place. In this embodiment, the height varying adapters 150 may be pushed together to be disengaged from each other. Alternatively, particularly in configurations wherein a single height varying adapter 150 forms a cross bar, the height varying adapter 150 may be removably screwed to the main surface 136 of table leg 104 at the first end 152, and screwed to the main surface 138 of the table leg 106 at the second end 154.

[0052] When needed to raise height of the variable height table 100, in one embodiment, the two cross bars 172 may be dismantled, i.e., four height varying adapters 150 are disengaged from each other and from the table legs 104, 106, 108, 110; and then the height varying adapters 150 are engaged to bottom ends 122, 124, 126, 128 of the table legs 104, 106, 108, 110. Such an engagement between the height varying adapters 150 and the table legs 104, 106, 108, 110 raises the height of the variable height table 100. For such an engagement, the height varying adapters 150 have engagement features (e.g., threaded bolts, screws, insert

posts, hinges and/or the like) that removably engage with complementary engagement features (e.g., threaded sleeves, grooves, insert holes, and/or the like) at the bottom ends 122, 124, 126, 128 of the table legs 104, 106, 108, 110. For example, as shown in FIG. 2, the height varying adapter 150 has a threaded bolt 156 at the first end 152 that removably engages with a threaded sleeve 132 at the bottom end 122 of the table leg 104. Similar engagements between the other height varying adapters 150 and the table legs 106, 108, 110 are carried out. When not needed to raise the height of the variable height table 100, the threaded bolt 156 may be securely received in a groove/hole on the main surface 136 of the table leg 104. Optionally, the table legs 104, 106, 108, 110 may be detached from the table top 102 before engaging the height varying adapters 150 to the bottom ends 122, 124, 126, 128 of the table legs 104, 106, 108, 110.

[0053] The variable height table 100 further comprises plugs 146 disposed at bottom ends 122, 124, 126, 128 of the table legs 104, 106, 108, 110. The plugs 146 seal the bottom ends 122, 124, 126, 128 of the table legs 104, 106, 108, 110, thereby protecting finished floor surfaces on which the variable height table 100 is placed from scuffing and scratching. The plugs 146 may be disengaged from the bottom ends 122, 124, 126, 128 of the table legs 104, 106, 108, 110 and engaged to the grooves/holes left on the main surfaces 136, 138, 140, 142 of the table legs 104, 106, 108, 110, when the height varying adapters 150, 160 have been disengaged from the main surfaces 136, 138, 140, 142 of the table legs 104, 106, 108, 110 to raise the height of the variable height table 100. Such an arrangement using the plugs 146 provides a finished appearance to the variable height table 100.

[0054] Preferably, the height varying adapters 150 have geometry similar to geometry of the table legs 104, 106, 108, 110, such that, the table legs 104, 106, 108, 110 engage with the height varying adapters 150 to give a finished appearance. More specifically, the first end 152 of the height varying adapter 150 has geometry similar to the geometry of the bottom end 122 of table leg 104. As shown in FIG. 2, a height varying adapter 150 has a cylindrical shape with a diameter equal to a diameter of the table leg 104. The height varying adapter 150 has a height, such that, for this embodiment, two height varying adapters 150 may be disposed between the table legs 104 and 106 as the cross bar 172. Such similar geometries give a finished appearance to the table legs 104, 106, 108, 110, such that, the only difference in appearance of the table legs is the table legs being longer than the table legs 104, 106, 108, 110 without the height varying adapters 150 engaged to the bottom ends 122, 124, 126, 128.

[0055] In another embodiment, as shown in FIG. 3, a height varying adapter 250 is in the shape of a truncated cone that has uniformly decreasing diameter from a first end 252 to a second end 254, similar to the shape of a table leg 204 having uniformly decreasing diameter from a top end 212 to a bottom end 222. Also, the first end 252 of the height varying adapter 250 has a diameter equal to a diameter of the bottom end 222 of the table leg 204. As shown, the height varying adapter 250 has a threaded bolt 256 at the first end 252 that removably engages with a threaded sleeve 232 at the bottom end 222 of the table leg 204. Due to the similar geometries and the proper engagement between the height varying adapter 250 and the table leg 204, the difference in appearance of the table leg is the table leg appearing longer

than the table leg 204 without the height varying adapter 250 engaged to the bottom end of the table leg 204, and having uniformly decreasing diameter from a top end 212 of the table leg 204 to the second end 254 of the height varying adapter 250.

[0056] In another embodiment, as shown in FIG. 4, a height varying adapter 350 has a rounded geometry that has a diameter at a first end 352 greater than a diameter at a second end 354, similar to geometry of a table leg 304 that has a diameter at a top end 312 greater than a diameter at a bottom end 322. As shown, the height varying adapter 350 has a threaded bolt 356 at the first end 352 that removably engages with a threaded sleeve 332 at the bottom end 322 of the table leg 204.

[0057] To further raise the height of the variable height table 100, the two cross bars 174 may be dismantled, i.e., four height varying adapters 160 (Refer FIG. 1) may be disengaged from each other and from the table legs 104, 106, 108, 110; and then the height varying adapters 160 may be removably engaged to the second ends 154 of the height varying adapters 150. The height varying adapter 160 has a first end 162 and a second end 164 with a cylindrical geometry similar to the height varying adapter 150. As shown in FIG. 5, a height varying adapter 160 has a threaded bolt 166 at the first end 162 that removably engages with a threaded sleeve 158 at the second end 154 of the height varying adapter 150.

[0058] Similarly, another height varying adapter 260 having similar truncated cone geometry (as the height varying adapter 250 of FIG. 3) may be removably engaged to the second end 254 of the height varying adapter 250. In one embodiment, as shown in FIG. 6, a height varying adapter 260 has a threaded bolt 266 at a first end 262 that removably engages with a threaded sleeve 258 at the second end 254 of the height varying adapter 250. In this embodiment, the first end 262 of the height varying adapter 260 has a diameter equal to a diameter of the second end 254 of the height varying adapter 250, and then uniformly decreasing diameter to a second end 264 to provide a finished look. In another embodiment, as shown in FIG. 7, a height varying adapter 270 has a threaded bolt 276 at a second end 274 that removably engages with a threaded sleeve 258 at the second end 254 of the height varying adapter 250. In this embodiment, the height varying adapter 270 has the same dimensions as the height varying adapter 250 with uniformly decreasing diameter from a first end 272 to the second end 274.

[0059] Although, not shown in FIG. 1, the variable height table 100 may have additional cross bars extending laterally between the table legs 104 and 106 and between the table legs 108 and 110 at different vertical positions on the table legs 104, 106, 108, 110. Moreover, the variable height table 100 may have additional cross bars (not shown) extending laterally between the table legs 104 and 108 and between the table legs 106 and 110, or, in some embodiments, the variable height table 100 may have additional cross bars (not shown) extending diagonally between the table legs 104 and 110 and between the table legs 106 and 108.

[0060] The design of the variable height table 100 with the cross bars is such that the cross bars closest to floor are dismantled first, when needed to raise the height of the variable height table 100. Referring to FIG. 1, the cross bars

172 are dismantled when needed to raise the height of the height variable table 100; and then the cross bars 174 are dismantled when needed to further raise the height of the variable height table 100. Such a design and the sequential removal of the cross bars 172, 174 prevents the cross bars 172, 174 from obstructing the sliding of chairs under the variable height table 100.

[0061] For a variable height table, the height of the height varying adapters may be not be limited to a particular height, and the variable height table may have differently sized height varying adapters. The differently sized height varying adapters may be used to raise the table by different heights for serving different purposes. Referring to FIG. 8, a variable height table 400 has height varying adapters 450, 460 form cross bar 472 extending laterally between the table legs 404, 406. The table legs 404, 406 support a table top 402. The cross bar 472 has two height varying adapters 450 and two height varying adapters 460. The height varying adapters 450 may be engaged to each other at second ends 454 using engagement means 482 and engaged to second ends 464 of height varying adapters 460 at first ends 452 using engagement means 484, 486. The height varying adapters 460 may be engaged to main surface 442, 444 of table legs 404, 406 at first ends 462. When needed to raise the height, the height varying adapters 450 may be engaged to table legs 404, 406 to raise the variable height table by a greater height than if height varying adapters 460 were used; and when using both the height varying adapters 450, 460, the height of the variable height table 400 may be raised even by a greater height. The variable height table 400 further comprises plugs 446 disposed at bottom ends 422, 424 of the table legs 404, 406. The plugs 446 serve the same purpose as the plugs 146 of the variable height table 100 (See FIG. 1).

[0062] The present invention further provides variable height tables that not only have features for raising the height of the variable height table, but also, have features for increasing the overall size of the variable height table. Referring to FIGS. 9 and 10, a variable height table 500 has a two-piece shelf 580 for increasing the size of a table top 502. The table top 502 is engaged to top ends 512, 514, 516, 518 of table legs 504, 506, 508, 510. The variable height table 500 further comprises height varying adapters 550, 560 forming cross bars 572. The two-piece shelf 580 securely rests on the cross bars 572. The two-piece shelf 580 comprises two table leaves 582, 584 engaged to each other at first sides 586, 588 of the table leaves 582, 584. The two table leaves 582, 584 are engaged to each other using engagement means, such as, hinge systems, key-hole brackets and protruding heads/studs, loops and hooks, and other suitable engagement means. The engagement means are disposed on the underside of the two-piece shelf 580, thereby making the engagement means not visible to users.

[0063] The table leaves 582, 584 have cut out portions 596 at two corners of second sides 592, 594 of the table leaves 582, 584. The cut out portions 596 have a design that provides proper fitting of the table leaves 582, 584 with the table legs 504, 506, 508, 510, for example, the cut out portions 596 wrap around the table legs 504, 506, 508, 510 for proper fitting. Also, the cut out portions 596 have a finished appearance providing a decorative appearance to the variable height table 500.

[0064] When needed to increase the size of the table top 502, the table leaves 582, 584 may be disengaged from each

other, and engaged to opposite sides of the table top 502, wherein the table leaves 582, 584 are coplanar with the table top 502. Suitable engagement means including, hinge systems, key-hole brackets and protruding heads/studs, loops and hooks, and other suitable engagement means may be used to engage the table leaves 582, 584 to opposite sides of the table top 502. Additionally, the variable height table 500 may comprise a pair of support arms (not shown) to hold the table leaves 582, 584 on the opposite sides of the variable height table 500. The support arms are disposed on an inner surface (not shown) of the table top 502, such that, the support arms are not visible to users when the variable height table 500 is used without the table leaves 582, 584 engaged to the table top 502.

[0065] Referring to FIG. 10, the first sides 586, 588 of the table leaves 582, 584 are engaged to opposite sides 503, 505 of the table top 502. As shown, the variable height table 500 has a rectangular shape with the sides 503, 505, being longer than the sides 507, 509. In such cases, the table leaves 582, 584 may be engaged to shorter sides 507, 509 of the table top 502 to have a table top with a different dimension than when the table leaves 582, 584 are engaged to opposite sides 503, 505 of the table top 502. Also, if the table leaves 582, 584 are the same length as the table top 502, the table leaves 582, 584 may be pre-attached to opposite sides of the table top 502 with hinge systems, or other suitable engagement means. Although, as shown in FIG. 10, the table leaves 582, 584 are substantially rectangular in shape, the table leaves 582, 584 may have any desired shape and size that provide a finished appearance when attached to any of the sides of the table top 502.

[0066] Alternatively, or in addition, the variable height table 500 comprises a table frame 540 capable of housing the table top 502 and the table leaves 582, 584. In one embodiment, as shown in FIG. 11, the table frame 540 comprises a frame panel 541 with an outer periphery 542 and an inner periphery 543, and a window 544. The table frame 540 further comprises a skirt 545 disposed about the outer periphery 204 on an upper surface of the frame panel 541. The overall shape of the table frame 540 provides an enclosure for housing the table top 502 and the table leaves 582, 584. The table leaves 582, 584 are disposed under the table top 502, when housed in the table frame 540. The frame panel 541 has engagement features, for example, protruding head 547 or threaded bolt on an inner surface 548 of the skirt 545, that engage with complementary engagement features, for example, key-hole brackets 511 or threaded sleeve on table top 502. As shown in FIG. 11, the table top 502 and the table leaves 582, 584 are provided in a pre-engaged form, with the table leaves 582, 584 engaged to opposite sides of the table top 502.

[0067] In such embodiments, wherein the variable height table 500 comprises the table frame 540, the top ends 512, 514, 516, 518 of the table legs 504, 506, 508, 510 are engaged to an inner surface (not shown) of the table frame 540, thereby the table legs 504, 506, 508, 510 supporting the table frame 540. Optionally, decorative molding may be used on an outer surface 549 of the skirt 545 of the table frame 540. Also, in alternative embodiments, the table top 502 may be larger in size than the table frame 540, such that, the table leaves 582, 584 are housed in the table frame 540, and the table top rests on a top surface of the skirt 545.

[0068] When needed to increase the size of the table top 502, the table top 502 with the pre-engaged table leaves 582, 584 are removed out of the table frame 540, and the table leaves 582, 584 are spread out, such that, the overall size of the table top 502 is increased. If the table leaves 582, 584 are not pre-engaged to the table top 502, then the table leaves 582, 584 may be engaged to the table top 502, using suitable engagement means. Support arms (not shown) disposed on the inner surface may slide or rotate outside of the table frame 540 to hold the table leaves 582, 584.

[0069] In another embodiment, the present invention provides pedestal-style variable height tables having a single pedestal or a double pedestal (with or without trestle) and height varying adapters housed inside the pedestal. The height varying adapters have geometry, such that, the height varying adapters may fit into each other and may be finally housed in a pedestal when not used. Referring to FIGS. 12-18, a pedestal-style variable height table 600, is shown. The variable height table 600 comprises a substantially circular table top 602, a pedestal 612 supporting the table top 602, and height varying adapters 650, 660 housed in the pedestal 612 (See FIG. 13). More specifically, the height varying adapter 660, that is smaller in size than the height varying adapter 650, is housed inside the height varying adapter 650, and then both height varying adapters 650, 660 are housed in the pedestal 612. The pedestal 612 is engaged to table top 602 via a mounting plate 632 bolted to an inner surface (not shown) of the table top 602. The mounting plate 632 has mounting holes (not shown) capable of receiving mounting elements 618 at a first end 614 of the pedestal 612. Possible mounting elements include screws, nails, rivets, bolts, studs, and the like. The variable height table 600 further comprises a pedestal base 622 with a plurality of outgoing legs 624 for stabilizing the variable height table 600. The pedestal base 622 has mounting elements 626 that engage with mounting holes 620 (See FIGS. 14 and 16) at a second end 616 of the pedestal 612.

[0070] The pedestal 612 has a lamp shade like structure with a diameter at the second end 616 greater than a diameter at the first end 614. Similarly, the height varying adapters 650, 660 have a lamp shade like structure with diameter at second ends 654, 664 greater than diameter at first ends 652, 662. The height varying adapter 660 has a size smaller than a size of the height varying adapter 650, i.e., diameters at first end 662 and second end 664 of the height varying adapter 660 are lesser than the diameter at second end 654 of the height varying adapter 650, such that, the height varying adapter 660 may be suitably housed inside the height varying adapter 650. Similarly, the height varying adapter 650 has a size smaller than a size of the pedestal 612, i.e., diameters at first end 652 and second end 654 of the height varying adapter 650 are lesser than the diameter at second end 616 of the pedestal 612, such that, the height varying adapter 650 may be suitably housed in the pedestal 612.

[0071] When needed to raise the height of the height variable table 600, the height varying adapter 650 is removed from the pedestal 612 and disposed between the pedestal 612 and the table top 602. To access the height varying adapter 650, the pedestal 612 is rotated in a manner, such that, the mounting elements 618 at the first end 614 of the pedestal 612 are disengaged from mounting holes on the mounting plate 632, and the mounting elements 626 of the

pedestal base 622 are disengaged from the mounting holes 620 at the second end 616 of the pedestal 612, thereby providing easy access to the height varying adapter 650 housed in the pedestal 612.

[0072] The second end 654 of the height varying adapter 650 has mounting holes 658 (e.g., key holes) capable of receiving mounting elements 618 (e.g. studs) at the first end of the pedestal 612, thereby removably engaging the height varying adapter 650 to the pedestal 612 (See FIG. 14). Further, the height varying adapter 650 is engaged to the table top 602 via the mounting plate 632 bolted to the inner surface of the table top 602. The mounting plate 632 has mounting holes (not shown) capable of receiving mounting elements 656 at the first end 652 of the height varying adapter 650. In this configuration, the height varying adapter 660 may stay housed in the height varying adapter 650. Alternatively, the height varying adapter 660 may be taken out of the height varying adapter 650 and housed in the pedestal 612.

[0073] Referring to FIG. 15, to further raise the height of the height variable table 600, the height varying adapter 660 may be disposed between the height varying adapter 650 and the table top 602, in addition, to the height varying adapter 650 disposed between the pedestal 612 and the height varying adapter 660. Referring now to FIG. 16, the engagement between the pedestal and the height varying adapters 650, 660 are illustrated. As described above, the second end 654 of the height varying adapter 650 has mounting holes 658 (e.g., key holes) capable of receiving mounting elements 618 (e.g. studs) at the first end of the pedestal 612, thereby removably engaging the height varying adapter 650 to the pedestal 612. The second end 664 of the height varying adapter 660 has mounting holes 668 (e.g., key holes) capable of receiving mounting elements 656 (e.g. studs) at the first end of the height varying adapter 650, thereby removably engaging the height varying adapter 660 to the height varying adapter 650. Further, the height varying adapter 660 is engaged to the table top 602 via the mounting plate 632 bolted to the inner surface (not shown) of the table top 602. The mounting plate 632 has mounting holes (not shown) capable of receiving mounting elements 666 at the first end 662 of the height varying adapter 660.

[0074] Also, similar to the embodiment in FIG. 9, the variable height table 600 has features for increasing the overall size of the variable height table 600. Referring to FIGS. 17 and 18, the variable height table 600 has table leaves 672, 674, 676, 678 engaged to the table top 602, thereby increasing the size of the table top 602. The table leaves 672, 674, 676, 678 have an arc shape that are sized in a manner to surround the circular table top 602 completely, such that, the outer edges of the table leaves 672, 674, 676, 678 give a finished appearance of an apron or molding of the table top 602. In this configuration, as shown in FIG. 18, the table leaves 672, 674, 676, 678 are engaged to each other and to the table top 602 using bracket and protruding head systems 682. Other suitable engagement means include, but are not limited to, hinge systems, and loops and hooks.

[0075] The table leaves 672, 674, 676, 678 are stored on an underside of the table top 602, thereby making the table leaves 672, 674, 676, 678 not visible to users when the table leaves 672, 674, 676, 678 are not engaged to the table top



**602** for increasing the size. In one embodiment, the table leaves **672, 674** are stacked on top of each other and are held on the under a side of the table top **602**; and the table leaves **676, 678** are stacked on top of each other and are held on the under an opposite side of the table top **602**.

[0076] The table top **602** and the table leaves **672, 674, 676, 678** may be made of any material that provides an aesthetic appearance to the variable height table **600**. Suitable materials include, but are not limited to, wood, metal, Plexiglas (transparent or translucent) and other equivalent materials ranging from clear to colored materials. In one embodiment, the table top **602** and the table leaves **672, 674, 676, 678** are made of a clear glass material. In such embodiment, the bracket and protruding head systems **682** have an ornamental/decorative design, since bracket and protruding head systems **682** would be visible through the clear glass material of table top **602** and the table leaves **672, 674, 676, 678**. Additional metal, chrome, wrought iron, and like material ornamental designs may be incorporated in the variable height table **600**.

[0077] Preferably, height varying adapters of a pedestal-style variable height table are designed in such a manner that table legs and/or pedestal appear as a single piece. Also, desirable is that the seams where the different pieces engage together are not visible. This can be achieved using an ornamental design or alternatively using a configuration wherein one piece overlaps the other.

[0078] In some embodiments, pedestal-style tables may have an additional ornamental center support that may have engagement features for removably engaging with complementary engagement features on table top and pedestal. Referring to FIG. 19, a variable height table **700**, is shown having an ornamental center support **750** disposed between a table top **702** and a pedestal base **722** with outgoing legs **728**. In one embodiment, the ornamental center support **750** has a center support base **752** with six keyholes **754**: three of the six keyholes **754** capable of removably receiving three protruding studs **704** on an inside surface of the table top **702**; and other three keyholes **754** capable of removably receiving three protruding studs **724** on the pedestal base **722**. Additionally, the pedestal base **722** has three keyholes **726** capable of removably receiving the three protruding studs **704** on the inside surface of the table top **702**, in absence of the ornamental centre support **750**.

[0079] When needed to raise the height of the variable height table **700**, the ornamental center support **750** is flipped over (See FIG. 20), such that, the center support base **754** of the ornamental center support **750** rests on the pedestal base **722** and the table top **702** is supported using center support arms **756**. The center support arms **756** have keyholes **758** that engage to the protruding studs **704** on the inside surface of the table top **702**.

[0080] In another embodiment, the present invention provides a lift-top variable height table. The lift-top variable height table has a lift table top in addition to a table top generally present in a variable height table. The lift table top is engaged to the table top in a manner, such that, the lift table top may be lifted for raising the height of the variable height table; or may be extended to a side for increasing the overall size of the variable height table. Referring to FIGS. 21-25, in one embodiment, a variable height table **800** comprises a first table top **802**; four table legs **804, 806, 808,**

**810** supporting the first table top **802**; a second table top **812** disposed above the first table top **802**; and a lift-up system **840** with an end portion **842** engaged to a bottom surface of the second table top **812**, a lift-up portion **844** disposed between the end portion **842** and the first table top **802** and a remaining portion **846** slidable on a roller bearing track **848**, the roller bearing track **848** disposed at a bottom surface of the first table top **802**. As shown in FIG. 21, the second table top **812** is in a 'top-down' position, wherein, the second table top **812** is disposed just above the first table top **802**, with the lift-up portion **844**, in a compressed position.

[0081] When needed to raise height of the variable height table **800**, the second table top **812** may be lifted to a 'top-up' position (See FIG. 22), wherein the second table top **812** is at a substantial height above the first table top **802**, with the lift-up portion **844** in an extended position. The lift-up portion **844** has a pressure spring with a stop mechanism that is capable of holding the second table top **812** in the 'top-up' position. In the 'top-up' position, the variable height table **800** may be used as a lift-top coffee table. In one embodiment, the second table top **812** rises to a height of about 10 inches above the first table top **802**.

[0082] When needed to increase the size of the variable height table **800**, the second table top **812** may be moved to a 'side' position, relative to the first table top **802**, such that, the second table top **812** configures a coplanar orientation with the first table top **802** on a side of the first table top **802** (See FIG. 24). For such a shifting of the second table top **812**, pressure is applied horizontally to the second table top **812**, causing the lift-up portion **844** to open up in a substantially straight orientation (See FIG. 23). With further application of pressure horizontally, the remaining portion **846** may be pulled away on the roller bearing track **848**, such that, the second table top **812** slides towards the 'side' position and adjustably fits alongside the first table top **802** (See FIG. 24).

[0083] The variable height table **800** further comprises two size varying adapters **850** for supporting the second table top **812** in the 'side' position. Referring to FIG. 25, the two size varying adapters **850** are disposed as cross bars extending laterally between table legs **804, 808,** and **806, 810**. The size varying adapters **850** may be engaged at their opposite ends to main surface **832, 834, 836, 838** of the table legs **804, 806, 808, 810**. In the 'side' position of the second table top **812**, the table legs **804, 806** may be disengaged from the first table top **802**, and engaged to bottom ends **826, 828** of the table legs of **808, 810**; while the size varying adapters **850** may be disengaged from the table legs **804, 806, 808, 810** and engaged to lower surface (not shown) of the second table top **812**.

[0084] Additionally, the variable height table **800** comprises height varying adapters **860** that are disposed in sets of two height varying adapters **860** forming cross bars **872**. The cross bars **872** may extend laterally between the table legs **804, 806,** and **808, 810**. The height varying adapters **860** may be engaged to each other at second ends (not numbered) of the height varying adapters **860**, and engaged to main surface **832, 834, 836, 838** of the table legs **804, 806, 808, 810** at first ends (not numbered) of the height varying adapters **860**. In one embodiment, two height varying adapters **860** are engaged to each other at second ends using

engagement means in the form of a knurl **886** with a spring (not shown) pushing outwards to hold the height varying adapters **860** in place.

[0085] When needed to raise the height of the variable height table **800** with increased size of the table top **802**, in one embodiment, the two cross bars **872** may be dismantled, i.e., four height varying adapters **860** are disengaged from each other and from table legs **804, 806, 808, 810**; and then the height varying adapters **860** are engaged to bottom ends **822, 824** of the table legs **804, 806** and to bottom ends **854** of the two size varying adapters **850**. For such an engagement, the height varying adapters **860** have engagement features (e.g., threaded bolts, screws, insert posts, hinges and/or the like) that removably engage with complementary engagement features (e.g., threaded sleeves, grooves, insert holes, and/or the like) at the bottom ends **822, 824** of the table legs **804, 806** and at bottom ends **854** of the size varying adapters **850**.

[0086] In an exemplary embodiment, the present invention provides a variable height table in the form of an end-table that has features for raising the height of the end-table and features for increasing the overall size of the end table, such that, the end table may be converted to a bench, or a sofa table, or a pub table, or a chair, or the like. Referring to FIGS. 26-30, an endtable **900** comprises a substantially rectangular table top **902** and four table legs **904, 906, 908, 910** supporting the table top. The end table **900** further comprises at least one table leaf for increasing the overall size of the table top **902**. In one embodiment, the end table **900** comprises two table leaves **982, 984** engaged to opposite sides **903, 905** the table top **902**, using engagement means, such as, hinge systems, key-hole brackets and protruding heads/studs, loops and hooks, and other suitable engagement means. Also, the table leaves **982, 984** and the table top **902** may be disposed with respect to each other, such that, the table leaves **982, 984** and the table top **902** appear as one single piece.

[0087] The end-table **900** further comprises size varying adapters for supporting the table leaves **982, 984**, when the table leaves **982, 984** may be extended to an 'open position', such that, the table leaves **982, 984** configure a coplanar orientation with the table top **902**. Referring to FIG. 26, four size varying adapters **950** are disposed as cross bars extending laterally between the table legs **904, 906, 908, 910**. The size varying adapters **950** may be engaged at their opposite ends to main surface **932, 934, 936, 938** of table legs **904, 906, 908, 910**.

[0088] Referring to FIG. 27, when needed to increase the size of the table top **902**, the table leaf **982** may be raised to an 'open' position, such that, the table leaf **982** configures a coplanar orientation with the table top **902** on a side **903** of the table top **902**. Two size varying adapters **950** may be disengaged from the table legs **904, 906, 908, 910**; and then the two size varying adapters **950** may be engaged to lower surface (not shown) of the table leaf **982**, for supporting the table leaf **982** in the 'open' position. For such an engagement, the size varying adapters **950** have engagement features (e.g., threaded bolts, screws, insert posts, hinges and/or the like) that removably engage with complementary engagement features (e.g., threaded sleeves, grooves, insert holes, and/or the like) on the lower surface of the table leaf **982**.

[0089] To further increase the size of the table top **902**, the table leaf **984** may be raised to an 'open' position, such that, the table leaf **984** configures a coplanar orientation with the table top **902** on a side **905** of the table top **902** (Refer FIG. 28). The other two size varying adapters **950** may be disengaged from the table legs **904, 906, 908, 910**; and then the size varying adapters **950** may be engaged to lower surface (not shown) of the table leaf **984**, for supporting the table leaf **984** in the 'open' position. For such an engagement, the size varying adapters **950** have engagement features (e.g., threaded bolts, screws, insert posts, hinges and/or the like) that removably engage with complementary engagement features (e.g., threaded sleeves, grooves, insert holes, and/or the like) on the lower surface of the table leaf **984**.

[0090] As shown in FIG. 28, the end-table **900** has eight table legs, i.e., four table legs **904, 906, 908, 910** and four size varying adapters **950**. In an alternative embodiment, the end-table **900** may comprise six table legs. For example, only two out of the four table legs **904, 906, 908, 910** may be used and be engaged to an intermediate position on lower surface (not shown) of the table top **902**. In another alternative embodiment, the end-table **900** may comprise four table legs. For example, size varying adapters **950** may not be used for supporting the table leaves **982, 984**, and, instead, engagement braces may be used to engage the table leaves **982, 984** to the table top **902**. Optionally, the table top **902** and the table leaves **982, 984** have designs for games, such as, chess, backgammon, and the like. The designs may become visible on raising the table leaves **982, 984** to the 'open' position.

[0091] Additionally, the end-table **900** comprises height varying adapters **960** that are disposed in sets of two height varying adapters **960** forming cross bars **972** (See FIG. 26). The cross bars **972** may extend laterally between the table legs **904, 906, 908, 910**. The height varying adapters **960** may be engaged to each other at second ends (not numbered) of the height varying adapters **960**, and engaged to main surface **932, 934, 936, 938** of the table legs **904, 906, 908, 910** at first ends (not numbered) of the height varying adapters **960**. In one embodiment, two height varying adapters **960** are engaged to each other at second ends using engagement means in the form of a knurl **986** with a spring (not shown) pushing outwards to hold the height varying adapters **960** in place.

[0092] Referring to FIG. 29, when needed to raise the height of the end-table **900** with increased size of the table top **902**, in one embodiment, the four cross bars **972** may be dismantled, i.e., eight height varying adapters **960** are disengaged from each other and from table legs **904, 906, 908, 910**; and then the height varying adapters **960** are engaged to bottom ends **922, 924, 926, 928** of the table legs **904, 906, 908, 910** and to bottom ends **954** of the four size varying adapters **950**. For such an engagement, the height varying adapters **960** have engagement features (e.g., threaded bolts, screws, insert posts, hinges and/or the like) that removably engage with complementary engagement features (e.g., threaded sleeves, grooves, insert holes, and/or the like) at the bottom ends **922, 924, 926, 928** of the table legs **904, 906, 908, 910** and at bottom ends **954** of size varying adapters **950**.

[0093] Also, as shown in FIG. 30, the end-table **900** may be converted to a chair by lifting the table leaf **982** to an

'upright' position, such that, the table leaf **982** extends perpendicularly to the table top in an upward direction forming a backrest of the table top **902**, the table top **902** serving as a seat of the chair. The table leaf **982** may be supported in the 'upright' position, using engaging mechanisms that may swivel into place from the underside of the table top **902**. Alternatively, the table leaf **984** may be lifted to an 'upright position' to form a chair. Additionally, when needed to raise the height of such a chair, two cross bars **972** may be dismantled, i.e., four height varying adapters **960** are disengaged from each other and from table legs **904**, **906**, **908**, **910**; and then the height varying adapters **960** are engaged to bottom ends **922**, **924**, **926**, **928** of the table legs **904**, **906**, **908**, **910**.

[0094] Referring to FIG. **31**, a variable height chair **1000**, is shown. The variable height chair **1000** comprises a seat **1002**, a backrest **1012** disposed on a back portion of the seat **1002**, and chair legs **1004**, **1006**, **1008**, **1010** supporting the seat **1002**. The variable height chair **1000** further comprises height varying adapters **1050**, **1060** disposed as cross bars extending laterally between the chair legs **1004**, **1006**, **1008**, **1010**. Each of the height varying adapters **1050**, **1060** are present in sets of four: on a first side between the chair legs **1004** and **1006**, on a second side between the chair legs **1008** and **1010**, on a front side between chair legs **1006** and **1010**, and on a back side between the chair legs **1004** and **1008**. The height varying adapters **1050**, **1060** may be engaged at their opposite ends to main surface **1032**, **1034**, **1036**, **1038** of chair legs **1004**, **1006**, **1008**, **1010**.

[0095] Such variable height chairs **1000** may be used in combination with the variable height tables provided by the present invention. When height of a height variable table is raised, a corresponding raise in height of the variable height chair **1000** provides a suitable variable height table-chair combination. For raising the height of the variable height chair **1000**, either of the height varying adapters **1050**, **1060**, or a combination, may be disengaged from between the chair legs **1004**, **1006**, **1008**, **1010** and engaged to bottom ends **1022**, **1024**, **1026**, **1028** of the chair legs **1004**, **1006**, **1008**, **1010**. Such an engagement between the height varying adapters **1050**, **1060**, and the chair legs **1004**, **1006**, **1008**, **1010** raises the height of the variable height chair **1000**. For such an engagement, the height varying adapters **1050**, **1060** have engagement features (e.g., threaded bolts, screws, insert posts, hinges and/or the like) that removably engage with complementary engagement features (e.g., threaded sleeves, grooves, insert holes, and/or the like) at the bottom ends **1022**, **1024**, **1026**, **1028** of the chair legs **1004**, **1006**, **1008**, **1010**.

[0096] Although, not shown in FIG. **31**, the variable height chair **1000** may have additional cross bars extending laterally between chair legs **1004**, **1006**, **1008**, **1010** at different vertical positions on the chair legs **1004**, **1006**, **1008**, **1010**. Moreover, the variable height chair **900** may have additional cross bars (not shown) extending diagonally between the chair legs **1004** and **1010** and between the chair legs **1006** and **1008**.

[0097] The foregoing descriptions of specific embodiments of the present invention have been presented for purposes of illustration and description. They are not intended to be exhaustive or to limit the invention to the precise forms disclosed, and obviously many modifications

and variations are possible in light of the above teaching. The embodiments were chosen and described in order to best explain the principles of the invention and its practical application, to thereby enable others skilled in the art to best utilize the invention and various embodiments with various modifications as are suited to the particular use contemplated. It is understood that various omissions, substitutions of equivalents are contemplated as circumstance may suggest or render expedient, but is intended to cover the application or implementation without departing from the spirit or scope of the claims of the present invention.

What is claimed is:

1. A multi-purpose variable height table-chair combination, comprising:

a variable height table having

a table top,

table legs supporting the table top, wherein the table top is engaged to top ends of the table legs, and

at least one set of height varying adapters removably disposed between the table legs, the height varying adapters configured to raise a height of the variable height table when engaged to bottom ends of the table legs;

at least one variable height chair having

a seat,

chair legs supporting the seat; and

at least one set of height varying adapters disposed between the chair legs, the height varying adapters configured to raise a height of the variable height chair when engaged to bottom ends of the chair legs, corresponding to the raise in the height of the variable height table.

2. The multi-purpose variable height table-chair combination of claim 1, wherein the height varying adapters of the variable height table form cross bars extending laterally between the table legs.

3. The multi-purpose variable height table-chair combination of claim 2, wherein two height varying adapters form a cross bar, such that, the height varying adapters are engaged to the table legs at first ends and engaged to each other at second ends.

4. The multi-purpose variable height table-chair combination of claim 1, wherein the height varying adapters of the variable height table have engagement features capable of removably engaging with complementary engagement features at the bottom ends of the table legs.

5. The multi-purpose variable height table-chair combination of claim 4, wherein the height varying adapters of the variable height table have a threaded bolt capable of removably engaging with a threaded sleeve at the bottom ends of the table legs.

6. The multi-purpose variable height table-chair combination of claim 1, wherein the variable height table has at least two sets of differently sized height varying adapters.

7. The multi-purpose variable height table-chair combination of claim 1, wherein the variable height table further comprises at least one table leaf capable of increasing size of the table top.

8. The multi-purpose variable height table-chair combination of claim 7, wherein the table leaf when engaged with

a side of the table top configures a coplanar orientation with the table top, thereby increasing size of the table top.

9. The multi-purpose variable height table-chair combination of claim 8, wherein the variable height table further comprises at least one set of size varying adapters disposed between the table legs, the size varying adapters capable of being engaged to lower surface of the table leaf for supporting the table leaf.

10. The multi-purpose variable height table-chair combination of claim 7, wherein the table leaf when engaged with a side of the table top extends perpendicularly to the table top in an upward direction, such that, the table leaf forms a backrest of the table top for converting the variable height table to a chair.

11. The multi-purpose variable height table-chair combination of claim 1, wherein the variable height table further comprises

a lift table top disposed over the table top; and

a lift-up system capable of

lifting the lift table top for varying the height of the lift table top above the table top, and

extending the lift table top to a side of the table top for increasing size of the table top.

12. The multi-purpose variable height table-chair combination of claim 1, wherein the height varying adapters of the variable height chair have engagement features capable of removably engaging with complementary engagement features at the bottom ends of the chair legs.

13. A variable height table, comprising:

a table top;

at least one table leaf capable of being engaged with the table top to increase size of the table top;

a table frame capable of housing the table top and the table leaf;

table legs supporting the table frame, wherein the table frame is engaged to top ends of the table legs; and

at least one set of height varying adapters disposed between the table legs, the height varying adapters

capable of being engaged to bottom ends of the table legs for raising the height of the variable height table, when removed from between the table legs.

14. The variable height table of claim 13, wherein the height varying adapters form cross bars extending laterally between the table legs.

15. The variable height table of claim 13, wherein the height varying adapters have engagement features capable of removably engaging with complementary engagement features at the bottom ends of the table legs.

16. A variable height table, comprising:

a table top;

at least one pedestal supporting the table top;

at least one set of height varying adapters housed in the pedestal, the height varying adapters capable of being engageably disposed between the pedestal and the table top for raising a height of the variable height table, when removed from within the pedestal.

17. The variable height table of claim 16, wherein the height varying adapters have first engagement features at a first end capable of removably engaging with complementary engagement features on an inner surface the table top.

18. The variable height table of claim 16, wherein the height varying adapters have second engagement features at a second end capable of removably engaging with complementary engagement features on the pedestal.

19. The variable height table of claim 16, further comprising a pedestal base engaged to a second end of the pedestal, the pedestal base having a plurality of outgoing legs for stabilizing the variable height table.

20. The variable height table of claim 16, further comprising a center support disposed between the pedestal and the table top, the center support capable of being flipped over, such that, a base of the center support rests on the pedestal and arms of the center support engage to the table top, thereby raising height of the variable height table.

\* \* \* \* \*