

(19) World Intellectual Property Organization
International Bureau



(43) International Publication Date
29 June 2006 (29.06.2006)

PCT

(10) International Publication Number
WO 2006/069053 A2

(51) International Patent Classification:
G01N 1/28 (2006.01)

(21) International Application Number:
PCT/US2005/046121

(22) International Filing Date:
19 December 2005 (19.12.2005)

(25) Filing Language: English

(26) Publication Language: English

(30) Priority Data:
60/638,430 22 December 2004 (22.12.2004) US
60/711,199 25 August 2005 (25.08.2005) US

(71) Applicant (for all designated States except US): CHARM SCIENCES, INC. [US/US]; 659 Andover Street, Lawrence, MA 01843-1032 (US).

(72) Inventors; and

(75) Inventors/Applicants (for US only): SKIFFINGTON, Richard, T. [US/US]; 35 Pleasant Street, North Reading,

MA 01864 (US). SALTER, Robert, S. [US/US]; 247 Summer Avenue, Reading, MA 01867 (US). FITCHEN, John, F. [US/US]; 9 Madison Street, Medford, MA 02155 (US).

(74) Agent: LONG, Richard, J.; Charm Sciences, Inc., 659 Andover Street, Lawrence, MA 01843-1032 (US).

(81) Designated States (unless otherwise indicated, for every kind of national protection available): AE, AG, AL, AM, AT, AU, AZ, BA, BB, BG, BR, BW, BY, BZ, CA, CH, CN, CO, CR, CU, CZ, DE, DK, DM, DZ, EC, EE, EG, ES, FI, GB, GD, GE, GH, GM, HR, HU, ID, IL, IN, IS, JP, KE, KG, KM, KN, KP, KR, KZ, LC, LK, LR, LS, LT, LU, LV, LY, MA, MD, MG, MK, MN, MW, MX, MZ, NA, NG, NI, NO, NZ, OM, PG, PH, PL, PT, RO, RU, SC, SD, SE, SG, SK, SL, SM, SY, TJ, TM, TN, TR, TT, TZ, UA, UG, US, UZ, VC, VN, YU, ZA, ZM, ZW.

(84) Designated States (unless otherwise indicated, for every kind of regional protection available): ARIPO (BW, GH, GM, KE, LS, MW, MZ, NA, SD, SL, SZ, TZ, UG, ZM, ZW), Eurasian (AM, AZ, BY, KG, KZ, MD, RU, TJ, TM), European (AT, BE, BG, CH, CY, CZ, DE, DK, EE, ES, FI,

[Continued on next page]

(54) Title: SAMPLING METHOD AND DEVICE

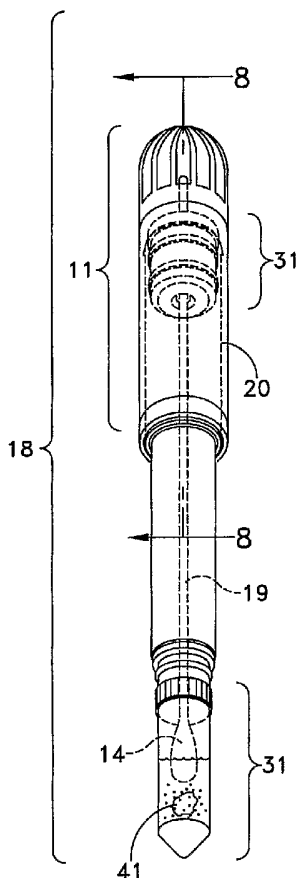

(57) Abstract: Disclosed herein is test device and method for detection of sample analytes in which after sampling has occurred a closure is provided. Such a test device and method can be usefully employed to detect a variety of analytes including microorganisms.

WO 2006/069053 A2



FR, GB, GR, HU, IE, IS, IT, LT, LU, LV, MC, NL, PL, PT, RO, SE, SI, SK, TR), OAPI (BF, BJ, CF, CG, CI, CM, GA, GN, GQ, GW, ML, MR, NE, SN, TD, TG).

— of inventorship (Rule 4.17(iv))

Declarations under Rule 4.17:

- as to applicant's entitlement to apply for and be granted a patent (Rule 4.17(ii))
- as to the applicant's entitlement to claim the priority of the earlier application (Rule 4.17(iii))

Published:

- without international search report and to be republished upon receipt of that report

For two-letter codes and other abbreviations, refer to the "Guidance Notes on Codes and Abbreviations" appearing at the beginning of each regular issue of the PCT Gazette.

Sampling Method and Device

Technical Field

[0001] This application relates to methods and devices for sampling surfaces and materials to detect analytes on the sampled surface or within the sampled materials.

Reference to Prior Applications

[0002] This application is based on and claims priority from U.S. Provisional Patent Application number 60/638,430, filed December 22, 2004, and U.S. Provisional Patent Application number 60/711,199, filed August 25, 2005, the teachings of both of which are incorporated herein by this reference.

Background

[0003] Devices and methods for sampling surfaces and materials include self-contained, single service swabs for removing a sample from a surface and detecting adenosine triphosphate (ATP) in the sample by measuring the reaction of sample ATP with luciferin-luciferase to generate luminescence (light). The light from the reaction can be detected using an analyzer such as a luminometer, photodiode or photomultiplier. It is desirable to provide similar such devices and methods that are adapted to provide a stable test unit, for example one that will not leak and/or engage prematurely. Such a test unit can allow for culturing and/or detecting possibly hazardous microbes; maintaining the integrity of samples in non-laboratory conditions; transporting test samples such as DNA samples for later testing, for example in forensics; and maintaining samples in extreme conditions such as occur during space travel. It is also beneficial to provide a means to eliminate or reduce the risk that hazardous substances, for example cultured pathogens, will be released into the environment from the test unit.

Brief Description of the Figures

[0004] Figure 1 is a perspective view of a plug that can be used to decrease or eliminate the risk of liquid leaking.

[0005] Figure 2 is a cross-sectional view of the plug of figure 1.

[0006] Figure 3 is a perspective view including a partial elevation view of a test unit with a probe in the pre-use position within the test unit.

[0007] Figure 4 is a perspective view of the swab cover with attached probe disengaged from the test unit body.

[0008] Figure 5 is an enlarged cross-sectional view of the swab cover including plug in pre-use position.

[0009] Figure 6 is a perspective view including partial elevation view of a test unit with probe breaking through a frangible seal to contact reagent within the test unit.

[0010] Figure 7 is a perspective view including partial elevation view of a test unit in the use position with probe contacting reagents in the bottom of a test vial and showing the plug forming a closure.

[0011] Figure 8 is a cross-sectional view of the swab cover with plug forming a closure.

[0012] Figure 9 is perspective view including partial elevation view of the test unit within a containment bag.

[0013] Figure 10 is a cross-sectional view of the swab cover enclosed within a containment bag with plug forming a closure. A disinfectant tablet is shown attached to the bottom of the plug.

[0014] Figure 11 is a perspective and partial elevation view of a test unit with probe engaged into the test vial and showing the plug forming a closure with the test unit sealed within a containment bag.

[0015] Figure 12 is a cross-sectional view of the swab cover shown in the use position and oriented so that material from the test vial can flow back to contact the disinfectant that is shown attached at the bottom of the plug.

[0016] Figure 13 is a perspective partial elevation of the test unit in the pre-use position within the containment bag that also includes a disinfectant pouch.

[0017] Figure 14 is a cross-sectional view of the swab cap and a disinfectant pouch within a containment bag.

[0018] Figure 15 is a perspective and partial elevation view of the test unit with the test vial removed from the body of the test unit to allow the test material to contact the disinfectant released from the disinfectant pouch.

[0019] Figure 16 is a perspective view including a partial elevation view of a test unit with a probe in the pre-use position within the test unit and including a removable sleeve and o-ring holder.

[0020] Figure 17 is a partially exploded perspective view of a test unit with cover partially disengaged from the test unit body.

[0021] Figure 18 is a partially exploded perspective view of a test unit showing the test unit body without the cover and showing the removable sleeve and o-ring holder.

[0022] Figure 19 is an enlarged partial cross-sectional view of a test unit in the pre-use position.

[0023] Figure 20 is an enlarged partial cross-sectional view of a section of figure 19.

[0024] Figure 21 is an enlarged partial cross-sectional view of a section of figure 19.

[0025] Figure 22 is an exploded perspective view of a swab cover with probe and hollow body section of a test unit with probe removed from the body.

[0026] Figure 23 is a perspective view including partial elevation view of a test unit with removable sleeve removed and probe engaged into a test vial.

[0027] Figure 24 is an enlarged partial cross-sectional view of a test unit in the post-use, engaged/closure position.

[0028] Figure 25 is an enlarged partial cross-sectional view of a section of figure 24.

[0029] Figure 26 is cross-sectional view of the bottom portion of a test unit with probe puncturing the frangible seal on a test vial.

[0030] Figure 27 is a perspective view including a partial elevation view of a test unit with a probe in the pre-use position within a test unit and with optional niblet within the test vial.

[0031] Figure 28 is cross-sectional view of the bottom portion of a test unit with probe puncturing the frangible seal on the test vial and in position to puncture the first frangible seal of an optional niblet.

[0032] Figure 29 is a perspective view including a partial elevation view of a test unit with a probe in the pre-use position within the test unit and an outlet/inlet valve through which the environment within the test unit can be adjusted and maintained.

Summary

[0033] Aspects include detecting an analyte in a sample using an elongated test unit, the test unit including a hollow section with a first open end and second open end. A probe can be within the hollow section, the probe including a first probe end and a second probe end. A test unit cover can be attached to the first end of the probe and the cover can be designed to enclose the first open end of the hollow section. A test vial can be attached to the second open end of the hollow section and can contain reagents sealed therein by a frangible seal. A closure can be provided to prevent material such as liquid from entering and/or leaving the test unit. The probe can be used to obtain a test sample to provide admixture of the sample on the probe with reagents within the test vial. The probe can be so used by removing the probe from the test unit, collecting a sample onto the probe to provide a sample-probe, inserting the sample-probe into the test unit and moving the sample-probe longitudinally through the frangible test vial seal to contact the reagents. The longitudinal movement of the sample-probe can engage one or a variety of closures. The engagement of the closure can be simultaneous with contact of the sample-probe

with the reagents. The closure can include a plug attached to the probe the plug designed and positioned so that moving the sample-probe longitudinally positions the plug to provide the closure, for example, between the peripheral wall of the plug and the inner diameter wall of the hollow section of the test unit. A closure can also be provided using an o-ring within an o-ring holder, the o-ring holder surrounding the test unit so that the test unit cover is secured into the o-ring holder to form the closure.

Description

[0034] Disclosed herein is a test unit, a test system and a test method for sampling a material or a surface of a material and detecting one or more analytes within the sample. Possible analytes include, but are not limited to, adenosine triphosphate, nucleic acids, small molecules such as antibiotics or toxins, proteins and/or microorganism. Various embodiments include allowing a sample to be taken from a material or surface and then contacted with reagents within a test unit while reducing or eliminating the risk of the reagents or the sample leaking out of the test unit by creating a closure. By closure we mean a barrier to substantially or completely prevent material, including liquid, from leaking out of the test unit and/or leaking into the test unit. Such embodiments can be useful when the reagents or analytes are dangerous or otherwise must be shielded from contact with the environment external to the test unit. Similarly, such embodiments can be used to protect the integrity of a collected sample, for example by protecting the sample from the environment external to the test unit.

[0035] U.S. Patent numbers 5,827,675, issued October 27, 1998; 5,965,453, issued October 12, 1999; 5,917,592, issued June 29, 1999; and 6,055,050, issued April 25, 2000, 6,180,395, issued January 30, 2001, all hereby incorporated by reference, describe obtaining and testing samples, for example for the presence of adenosine triphosphate (ATP) and alkaline phosphatase (AP). One commercially available ATP sampling and detection method is known as the POCKETSWAB (POCKETSWAB is a registered trademark of Charm Sciences, Inc., Lawrence, MA). In one aspect, the POCKETSWAB is adapted, as further described herein, to obtain a sample for analysis to determine the presence of, for example, particular proteins, molecules, microbes, sugars and/or nucleic acids.

[0036] An embodiment includes collecting a sample, such as a biological specimen, using a probe. The probe can be provided within a test unit. After collecting the sample the probe containing the sample (the sample-probe) can be contacted with reagents, for example reagents

provided within a test vial attached to the test unit. In an embodiment, a test vial is threadably attached to the bottom of the test unit. To avoid accidental removal of the test vial, whether or not threadably attached, the test vial can be secured to the bottom of the test unit, for example with adhesive such as an epoxy resin. A variety of techniques can be used, alone or with adhesive, to secure the test vial to the bottom portion of the test unit including encasing in shrink wrap. For example, a heat shrink can be used with tamper evident plastic such as cellulose or polyvinylchloride (PVC). The test vial can be a simple, single vial sealed at the top with a frangible seal and containing reagents therein. The test vial can also include one or more additional frangibly sealed reagent containers, hereinafter referred to as a niblet and/or additional internal frangible seals. Such niblets can be located above the test vial frangible seal, within the body of the test unit, or within the test vial.

[0037] Within the test vial that is secured to the test unit, can be a variety of substances, including: substances known in the art for nucleic acid detection; substances known in the art such as luciferin, luciferase and/or buffers for detecting ATP; and substances for culturing and/or detection of microorganisms, such as, for example, media known in the art for culturing and detection of *Listeria monocytogenes*.

[0038] Possibly useful culturing and/or detecting materials include those known in the art including those described in U.S. Patent number 5,728,542, issued March 17, 1998, and U.S. Patent number 5,605,812, issued February 25, 1997, the teachings of both of which are incorporated herein by this reference. When detecting microbes containment within a leak proof test unit is useful to protect against the escape of possibly harmful microbial culture into the external environment. The environmentally sealed test unit can also be useful in making the environment within the test unit favorable to microbial growth, for example anaerobic or facultative anaerobes, such as *Campylobacter*, can be grown. To provide a favorable environment for such microbes a valve can be built within the test unit, for example at the top of the test unit. The valve can be used to remove oxygen and/or add nitrogen to the internal environment of the test unit.

[0039] In another embodiment colorimetric or fluorometric indicators can be provided within the test unit such as in the test vial or in a niblet within or above the test vial. Such indicators can be general or specific to particular microbe genus or species, for example specific to particular

proteins expressed by a microbe. Such indicators can also be used to indicate generally aerobic or anaerobic growth.

[0040] Generally, the test vial can include any of a variety of materials depending on the target of detection. The materials can be in a variety of forms including for example, solid, liquid, powder, emulsion, suspension, tablet or combinations thereof.

[0041] The test vial can include or be composed of a variety of materials such as organic polymeric materials including polypropylene, polyethylene, polybutyrate, polyvinylchloride and polyurethane. Materials and components can be irradiated or otherwise treated to reduce or eliminate possible contamination. Test vials and niblets can be a variety of sizes, volumes and colors. Unlike test vials used when luminescence or color is to be detected, test vials used for nucleic acid storage need not be transparent.

[0042] Various materials, such as liquids, can be sealed within the test vials, such as by using a frangible seal on top of the test vial. Material that can be used to frangibly seal the test vial include a variety or combination of organic polymeric materials such as silicone, rubber, polyurethane, polyvinylchloride or inorganic material such as wax or foil material. The frangible seal can be in a variety of forms including a membrane. The frangible seal can also be replaced by a disc or valve that can be held in place by a variety of techniques including chemical and mechanical techniques. The frangible seal can be adapted to be penetrated by the probe or by a separate instrument. In an example, the probe is moved longitudinally, for example threadably, to a selected position. During the movement the frangible seal is punctured. After the frangible seal is punctured the sample is contacted with material within the test vial.

[0043] When the sample-probe contacts the material, for example reagents, within the test vial it may be desirable to: (i) engage or hold the sample-probe in place to maintain the sample-probe within the liquid in the test unit; and/or (ii) provide a closure to prevent liquid from leaking out of the test unit. In an embodiment, an o-ring style closure is provided. The closure can include an o-ring to lock the cover of the test unit in the engaged (post use) position with the probe within the test vial. The o-ring can be held within a device (an o-ring holder) that can be made of a variety or combination of materials including metal, rubber or plastic housing, for example polyvinylchloride. The o-ring holder can be a separate machined part or can be molded into the test unit. The o-ring holder can surround the test unit and can include an o-ring or other means

for engaging the cover so as to form the closure. The o-ring holder can also include a shoulder/ridge to hold the o-ring holder in place, such as with a press-fit. The cover can be hollow and in the shape of a cylinder with an open end and a closed end. When in the engaged position the open end of the cover can move longitudinally to surround a portion of the test unit and engage within the o-ring holder forming a closure.

[0044] The o-ring can be made from a synthetic rubber material such as a fluoroelastomer, for example VITON (VITON is a registered trademark of E. I. Du Pont de Nemours & Company, Wilmington, Delaware). Similarly, closures to engage the cover can be molded for a plastic-to-plastic interference fit connection. Such closures can be used alone or with additional closures to provide additional leak prevention such as in the form of an internal plug.

[0045] A plug type mechanism can be located within the cover and be designed to create a closure, such as an o-ring type closure, between the peripheral wall of the plug and the inner diameter wall of the body thereby reducing the risk of leakage into the external environment after the probe is engaged within the vial. Such a plug can be used alone or, for further leak prevention, in conjunction with an o-ring type closure mechanism surrounding the test unit as described above, to provide additional closure between the outer periphery of the test unit body and the inner wall of the swab cover.

[0046] The plug can be composed of a variety of materials including a variety of plastics, rubber and metal. The plug can be attached to the shaft of the probe, in a variety of ways and in a variety of configurations, so that the longitudinal movement of the probe to contact reagents also causes the plug to be positioned to form a closure. For example, the plug can be attached to the shaft of the probe such as through a bore in the plug center. The bore adapted for receiving the shaft, holding in place the shaft and forming a closure. The bore can be all the way through the plug so that the shaft can extend out of both ends of the plug, with one end of the shaft extending out to contact the cover and the other end extending out to the probe tip. In such an embodiment the peripheral wall of the probe can seal against the inner diameter wall of the plug bore, such as by using an o-ring type closure mechanism and/or glue, to prevent leakage. The plug can also include a ridge on one end of the plug so that a second closure is provided between the ridge of the plug and the top of one end of a hollow section of the test unit.

[0047] When using threads, or a sliding mechanism, or a weakened mechanical means to allow removal and reattachment of the cover portion of the test unit, it may be desired to provide a mechanism to prevent inadvertent engagement and puncturing of the frangible seal containing the reagents. In an embodiment a disposable impact sleeve (removable sleeve) can be made of, for example, a solid material such as an acrylic material or plastic material or plastic-like material. After removal of the cover portion the sleeve can be removed and discarded.

[0048] Examples of useful probes include a variety of swab like devices with an absorbent tip attached to a solid or semi-solid shaft. The probe can be composed of any or a combination of materials useful for absorbing, adsorbing or retaining a sample. Swab tip materials can include any type of porous material including rayon, Dacron, cotton, foam or a combination thereof. The tip can be pre-moistened with any one or more of a variety of liquids, depending on the need or application, or provided dry. If provided pre-moistened, the pre-moistening liquid can include, for example, buffer, sterile water, glycerin, diluents, wetting solutions, or other material desired to be mixed with the sample or useful for absorbing, neutralizing, stabilizing or maintaining a sample.

[0049] The probe can be hollow, for example the tip of the probe, such as a swab tip, can be located on the end of an elongated hollow straw-like shaft. When fluid flows from above the probe, the probe can be designed and positioned to allow fluid flow through the hollow shaft and into the swab tip. The shaft can also be designed to include within the hollow section a breakable cartridge containing reagents for mixing with a sample.

[0050] One or a plurality of additional frangibly sealed compartments (niblets) can also be provided within the test unit, for example within the top of the test vial or just above the test vial. The niblets can be composed of a variety of materials such as organic polymeric materials including polypropylene, polyethylene, polybutyrate, polyvinylchloride and polyurethane. Niblet and niblet materials can be irradiated or otherwise treated to reduce or eliminate possible contamination. Niblets can be a variety of sizes to hold a variety of quantities or volumes. Reagents within optional niblets can include a variety of materials depending on the target of detection. The materials within the niblets may be in the form of a solid, liquid, powder, emulsion, suspension, tablet or any combination thereof. Niblets can be sealed on both sides with frangible, puncturable seals. The frangible seals can be a variety or combination of organic polymeric materials such as silicone, rubber, polyurethane, polyvinylchloride or inorganic

material such as wax or foil material. Use of optional niblets allows additional reagents or reagent combinations to be provided with the test unit separate from the reagents within the test vial. During test operation the reagents within the niblet are contacted by puncturing the frangible seal for example with a sample-probe.

[0051] In an embodiment a niblet is located immediately below the test vial frangible seal within the top portion of the test vial. When niblets are located below the test vial frangible seal, the collector will first puncture the test vial frangible seal and then puncture the top frangible seal on the optional first niblet. The sample-probe can be contacted with material within the niblet and at a selected time the sample-probe can be used to puncture the bottom end of the niblet releasing the contents toward the test vial. To provide additional frangibly sealed reagents a second or more niblets can be included. If only one niblet is present then the contents of the niblet, combined with the sample, can be mixed within the test vial and with other test reagents. Alternatively, no niblets are used and all reagents are frangibly sealed within the test vial.

[0052] The test unit into which the test vial can be attached and within which a probe can be contained can be composed of a variety or combination of organic polymeric materials such as polyurethane, polyvinylchloride, polypropylene, polyethylene, polybutyrate.

[0053] In an embodiment, a cover of a test unit, including the probe, can be disconnected from the bottom portion by employing threads, or a slidably fit mechanism, or a weakened mechanical section or other means, for example by removing or unsealing or ripping a tape holding the cover onto the bottom portion of the test unit. Having the bottom portion and cover portion threadably connected allows easy disconnecting and connecting. After removing the probe it can be used to obtain a sample and then reconnected to the bottom portion for example by utilizing threads.

[0054] A disinfectant can be provided in a variety of forms including tablet, liquid and powder. In tablet form the disinfectant can be provided inside the leak proof test unit, for example attached to the bottom of the plug or attached to the inner wall of the test unit. A tablet can be located so that when the test unit is oriented with the cap down and test vial up the material from the test vial can flow into contact with the tablet.

[0055] Translucent plastic can be used so that reactions within the test unit can be observed. For example, the disinfectant can include a dye that is visible to the user when contacted with material from within the test vial.

[0056] Other embodiments include using dissolvable tape, dissolvable plastic, such as cellulose based plastics, a burstable pouch or other similar containers that can contain a disinfectant that will be released either on contact with test material, such as liquid material, or that can be released upon application of pressure by a user. Similarly, if required, additional test reagents can be supplied within containers, such as burstable pouches, within a containment bag.

[0057] Other embodiments include a heater, such as a steam sterilizer, for example those available commercially and used to heat baby bottles, within which the test unit can be heated to eliminate or reduce the risk of contact with potentially dangerous microorganism.

[0058] Other embodiments include sealing the test unit within a leakproof zip-lock type bag and/or adhesive seal bag. Embodiments include using materials for containment bags from autoclavable plastic material such as polypropylene. Such a bag can allow the customer to remove the test unit for use and then return the test unit to the bag such as for decontamination and disposal. Leak proof containment bag seals can be for example BITRAN (Associated Bag) leak proof zipper bag. Also within the containment bag can be a disinfectant such as a liquid in a burstable pouch that can allow the user to release the material from the test vial into contact with the disinfectant.

[0059] Containment bags and/or generally leak proof test units are particularly useful when potentially dangerous organisms are targeted for detection. In an embodiment in which *Listeria monocytogenes* is targeted for detection the test vial can contain media for detection of *L. monocytogenes*. Such media can contain colorimetric reagents that provide a color change in the presence of a glucosidase.

[0060] In other embodiments, a variety of tests can be run using one sample for example tests for chemicals, biowarfare agents, explosives, metals, toxins, poisons. In another embodiment, the device and methods described herein can be used when sample preparation is common to a variety of tests.

Description of the Drawings

[0061] Figure 1 shows a plug 31 with bore 32 for probe shaft 19 and outer o-rings 33 to provide a closure against the inner diameter of the body of the test unit. Also shown is a plug cap 40 that both acts as a stopper to prevent the swab tip from contacting the bottom portion of the test vial and also can be an additional closure to prevent leakage.

[0062] Figure 2 shows a plug 31 with outer o-rings 33 and inner o-rings 34 within the bore to provide a closure against the outer diameter of the probe shaft 19 and plug cap 40.

[0063] Figure 3 shows a test unit in the pre-use position. The probe shaft 19 is attached to the cover 11 which, in the pre-use position is above threads 12. A test vial 23 is secured to the bottom of the unit 18.

[0064] Figure 4 shows the cover 11 with probe (shaft 19 and tip 14) removed from the body of the test unit.

[0065] Figure 5 shows the pre-use position with the cover 11 with probe shaft 19 partially enclosed within plug 31 by inner o-rings 34. Also shown are outer o-rings 33 for providing a closure against the inner diameter of swab body and threads within cover 11 and plug cap 40. The shaft 19 is shown extending through the plug bore to contact the test unit cover 11 at one end of the shaft 19.

[0066] Figure 6 shows the cap 11 being turned to utilize the threads 12 on the test unit body and within the cover (figure 5) to drive the probe head 14 through frangible seals and into the test vial 23.

[0067] Figure 7 shows the plug in the engaged position within the cover 11 with probe head 14 contacting test reagents 41 within the test vial 23 thereby delivering a sample to the test reagents 41. Outer o-rings of the plug form a closure with the internal diameter 20 of the test unit body.

[0068] Figure 8 shows a cross-section of the plug 31 in the engaged position within the cover 11 with probe shaft 19 partially enclosed via o-rings 34 within plug 31 and with plug 31 in the engaged position to provide a closure against the internal diameter 20 of the test unit body using the outer o-rings 33. Also shown is plug cap 40 positioned against one end 42 of a hollow

section of the test unit. For clarity, figure 8 shows cap 40 not touching the one end 42 of the hollow section. In operation, cap 40 contacts 42. Figure 9 shows the test unit within a sealed containment bag.

[0069] Figure 10 shows the cover 11 of the test unit within the containment bag 50 including sealing means 51 at top allowing removal of test unit from containment bag for obtaining sample and placement into containment bag after sample is obtained. Also shown is disinfectant tablet 52 attached to the bottom of the plug 31.

[0070] Figure 11 shows the test unit within a sealed containment bag after removal to obtain sample, replacement into bag and contacting of sample with reagents within test vial with disinfectant table at bottom of plug.

[0071] Figure 12 shows the test unit cover in position to allow material from the test vial to contact the disinfectant tablet 52.

[0072] Figure 13 shows the test unit within a sealed containment bag with a disinfectant pouch 54 that contains the disinfectant that can be released to contact reagents and sample released from the test vial after testing.

[0073] Figure 14 shows the cross-section of figure 13 including disinfectant pouch.

[0074] Figure 15 shows the post-testing disengagement of the test vial from the test unit body to allow material from the test vial to contact disinfectant released from the disinfectant bag. Although probe head 14 is shown separate from probe shaft 19, such scenario is not required.

[0075] Figure 16 shows an embodiment with the probe 14 in the pre-use position within the test unit 18. The probe 14 is attached to the cover 11 which, in the pre-use position is above threads 16. A removable sleeve 12 covering the threads 16 prevents the cover 11, with threads therein, from prematurely engaging the threads 16 on the test unit body and prematurely moving into the use position. The removable sleeve 12 is shown resting in an o-ring holder 15 that is in a press-fit arrangement on the test unit 18. A test vial 23 is secured to the bottom of the unit 18.

[0076] Figure 17 shows a partially exploded perspective view of the unit 18 of figure 16 with cover 11 disengaged from the test unit body and away from the removable sleeve 12 so that the sleeve can be removed prior to engaging the threads 16.

[0077] Figure 18 is a partially exploded perspective view of the unit 18 of figure 16 showing the test unit body 19 without the cover and the removable sleeve 12 and o-ring holder 15 separated from the test unit. The o-ring holder 15 includes an o-ring 10 for engaging the cover and a shoulder/ridge 11 to enable the o-ring holder 5 to be press-fit against the shoulder/ridge 12.

[0078] Figure 19 is an enlarged partial cross-sectional view of the unit of figure 16 in the pre-use position showing an o-ring 20 within an o-ring holder 15 around the test unit. Also shown is the o-ring holder 15 press-fit over the test unit with a shoulder/ridge 21 within the o-ring holder 15 press-fit against the shoulder/ridge on the test unit. The removable sleeve 12 is also shown within the o-ring holder 15.

[0079] Figure 20 is an enlarged partial cross-sectional view of the cover 11 with removable sleeve 12 preventing engagement of the cover 11.

[0080] Figure 21 is an enlarged partial cross-sectional view showing the o-ring 20, o-ring holder 15 and shoulder/ridge 21 to allow the o-ring holder 15 to be press-fit onto the unit. The removable sleeve 12 is also shown within the o-ring holder 15.

[0081] Figure 22 is a perspective view of the unit of figure 16 showing the cover 11 with probe 14 removed from the body and removable sleeve 12 being removed from the test unit body to allow threadable engagement.

[0082] Figure 23 is a perspective view and partial elevation view of the unit of figure 16 with removable sleeve 12 removed and probe 14 engaged into the test vial 23. The probe 14 punctures the one or more frangible seals of the test vial 23 to contact the reagents 17 within the test vial 23.

[0083] Figure 24 is an enlarged partial cross-sectional view of the unit shown in figure 16 with the o-ring holder 15 and o-ring 20 with cover 11 engaged into the o-ring 20, in the post-use position. The removable sleeve 12 has been removed.

[0084] Figure 25 is an enlarged partial cross-sectional view of a section of figure 24 showing the o-ring **20** within o-ring holder **15** and cover **11**.

[0085] Figure 26 is a partial cross-sectional view of the bottom portion of the unit shown in figure 16 with probe **14** puncturing the frangible seal **26** on the test vial **23**.

[0086] Figure 27 is a perspective view including a partial elevation view of a test unit **18** with a probe **14** in the pre-use position within the test unit **18**. Also shown is an optional niblet **24** containing additional reagents separated from the reagents **17** at the bottom of the test vial **23**.

[0087] Figure 28 is cross-sectional view of the bottom portion of the unit shown in figure 27 with probe puncturing the frangible seal **26** on the test vial **23** and in position to puncture the first frangible seal **30** of the optional niblet **24**.

[0088] Figure 29 is a perspective view including a partial elevation view of a test unit **18** with a probe **14** in the pre-use position within the test unit **18**. Also shown is an outlet/inlet valve **28** through which the environment within the test unit can be adjusted and maintained, for example through the removal of oxygen or the addition of nitrogen. The optional one or more niblets **24** can also be included with additional reagents.

Claims

1. A method for detecting an analyte in a sample, the method comprising:
 - a) providing an elongated test unit, the test unit comprising: (i) a hollow section having a first open end and second open end; (ii) a probe within the hollow section, the probe comprising a first probe end and a second probe end; (iii) a test unit cover to which said first end of the probe is attached, the cover adapted to enclose said first open end of the hollow section; (iv) a test vial, at the second open end of the hollow section, containing reagents sealed therein by a frangible seal; (v) closure means to provide liquid flow resistance, the test unit constructed and arranged to obtain a test sample on the probe and to provide admixture of the sample on the probe with reagents within the test vial;
 - b) removing the probe from the test unit;
 - c) collecting a sample onto the probe to provide a sample-probe;
 - d) inserting the sample-probe into the test unit;
 - e) moving the sample-probe longitudinally through the frangible test vial seal to contact the reagents,wherein moving the sample-probe longitudinally engages said closure means.
2. The method of claim 1 wherein said closure means comprises a plug attached to said probe and wherein moving the sample-probe longitudinally positions the plug to provide the closure.
3. The method of claim 2 wherein the closure is between the peripheral wall of the plug and the inner diameter wall of the hollow section of the test unit.
4. The method of claim 1 wherein the closure means comprises an o-ring within an o-ring holder, the o-ring holder surrounding the test unit, wherein the cover is secured into the o-ring holder to form the closure.
5. The method of claim 1 wherein the probe comprises a shaft with a swab at the second probe end.
6. The method of claim 1 wherein the reagents comprise media for growth of a microorganism.
7. The method of claim 6 wherein said microorganism comprises a pathogen.

8. Then method of claim 6 wherein said microorganism comprises *Listeria monocytogenes*.
9. The method of claim 1 wherein said reagents comprise media for growth of a microorganism and further comprise a colorimetric indicator of the presence or absence of said microorganism.
10. The method of claim 1 further comprising providing a removable sleeve, the sleeve adapted to prevent the premature longitudinal movement of the probe.
11. The method of claim 1 further comprising providing a niblet within the test vial, the niblet containing reagents to be combined with the reagents within the test vial.
12. The method of claim 1 further comprising providing a disinfectant tablet attached to the plug and positioned to be contacted by the reagents and the sample when said detecting is complete.
13. A method for detecting an analyte in a sample, the method comprising:
- a) providing an elongated test unit, the test unit comprising: (i) a hollow section having a one open end and a second open end; (ii) a probe within the hollow section, the probe comprising a first probe end and a second probe end; (iii) a test unit cover to which said first probe end is attached, the cover adapted to enclose said one open end of the hollow section; (iv) a plug attached to said probe; and (v) a test vial, at the other end of the hollow section, containing reagents sealed therein by a frangible seal, the test unit constructed and arranged to obtain a test sample on the probe and to provide admixture of the sample on the probe with reagents within the test vial;
 - b) removing the probe from the test unit;
 - c) collecting a sample onto the probe to provide a sample-probe;
 - d) inserting the sample-probe into the test unit;
 - e) moving the sample-probe longitudinally through the frangible test vial seal to contact the reagents,
- wherein moving the sample-probe longitudinally not only causes the sample-probe to contact reagents but also positions the plug to create a closure.
14. The method of claim 13 wherein the closure is between the peripheral wall of the plug and the inner diameter wall of the hollow section of the test unit.

15. The method of claim 13 wherein the closure is created concurrently with contact of the sample-probe with the reagents.
16. The method of claim 13 wherein the peripheral wall of the plug comprises an o-ring.
17. The method of claim 13 wherein the probe comprises a shaft with a swab at the second probe end.
18. The method of claim 13 wherein the plug comprises a bore and wherein the probe is positioned within the bore.
19. The method of claim 18 wherein the plug comprises an o-ring positioned within the bore.
20. The method of claim 13 wherein the reagents comprise media for growth of a microorganism.
21. The method of claim 20 wherein said microorganism comprises a pathogen.
22. Then method of claim 21 wherein said microorganism comprises *Listeria monocytogenes*.
23. The method of claim 13 wherein said reagents comprise media for growth of a microorganism and further comprise a colorimetric indicator of the presence or absence of said microorganism.
24. The method of claim 13 further comprising providing a removable sleeve, the sleeve adapted to prevent the premature longitudinal movement of the probe.
25. The method of claim 13 further comprising providing a niblet within the test vial, the niblet containing reagents to be combined with the reagents within the test vial.
26. The method of claim 13 further comprising providing a disinfectant tablet attached to the plug and positioned to be contacted by the reagents and the sample when said detecting is complete.

27. An elongated test unit comprising:

- a) a hollow chamber having a first open end and second open;
 - b) a probe within said hollow chamber, the probe comprising a shaft and a tip, the shaft being attached to both a cover for the first open end of the hollow chamber and a plug, the cover adapted for causing the longitudinal movement of the probe to a selected use position;
 - c) a test vial secured to the second open end of the test unit, the test vial adapted to store reagents prior to use and for contact with the tip when the probe is in the selected use position,
- wherein when the probe is moved longitudinally to the selected use position the plug forms a closure.

28. The test unit of claim 27 wherein the closure is between the peripheral wall of the plug and the inner diameter wall of the test unit.

29. The test unit of claim 28 further characterized in that the plug comprises a bore extending therethrough, the plug bore having an entrance end and an exit end, the plug bore being shaped to both receive the probe and to form a closure between the peripheral wall of the probe and the internal wall of the plug.

30. The test unit of claim 29 wherein the closure between the peripheral wall of the probe and the internal wall of the plug comprise an o-ring.

31. The test unit of claim 28 wherein the closure between the peripheral wall of the plug and the internal wall of the hollow section of the test unit comprises an o-ring.

32. The test unit of claim 27 wherein the reagents comprise media for growth of a microorganism.

33. The test unit of claim 32 wherein said microorganism comprises a pathogen.

34. The test unit of claim 32 wherein said microorganisms comprises *Listeria monocytogenes*.

35. The test unit of claim 27 wherein said reagents comprise media for growth of a microorganism and further comprise a colorimetric indicator of the presence or absence of said microorganism.

36. The test unit of claim 27 further comprising providing a removable sleeve, the sleeve adapted to prevent the premature longitudinal movement of the probe.

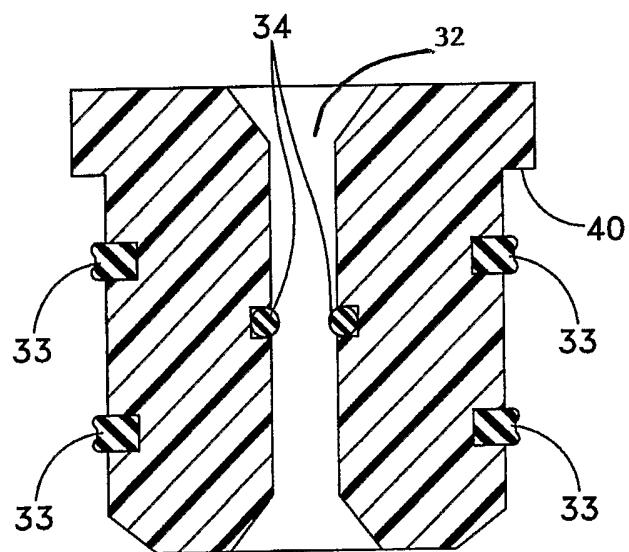
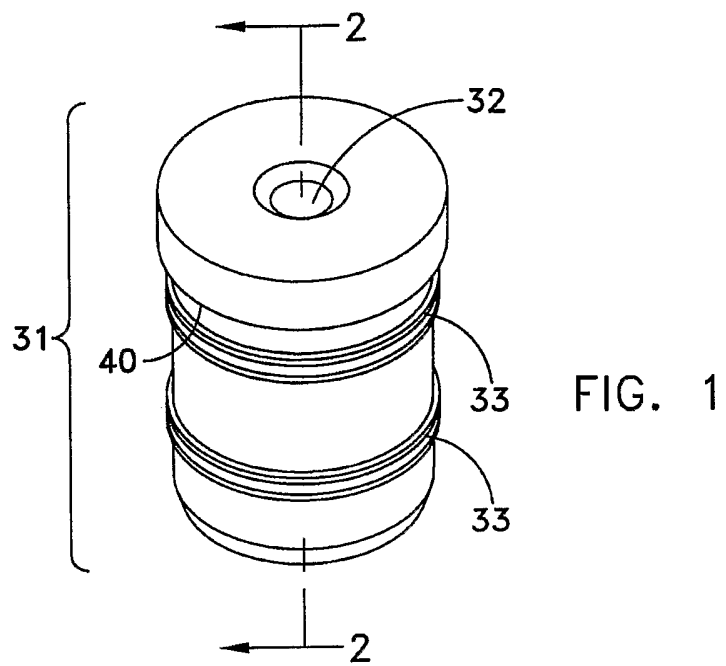

FIG. 2

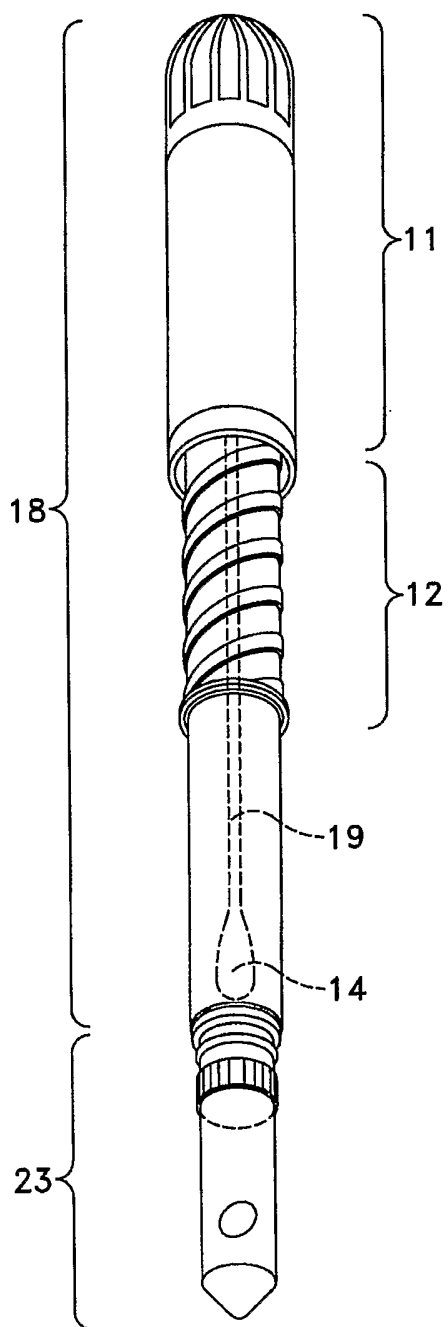

FIG. 3

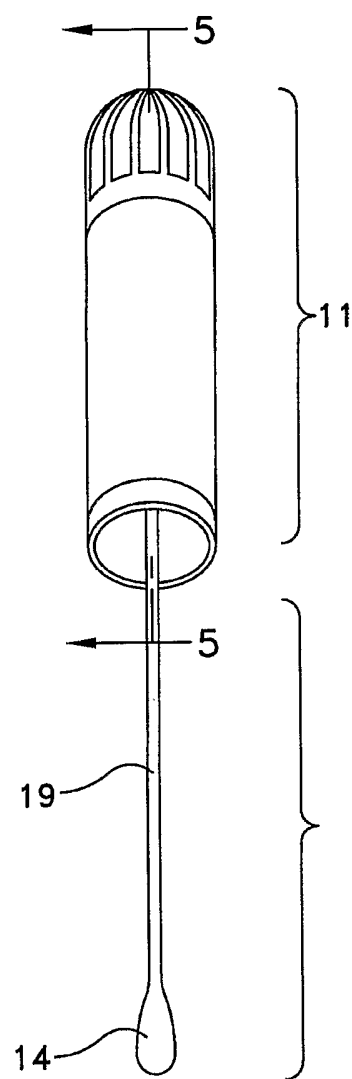
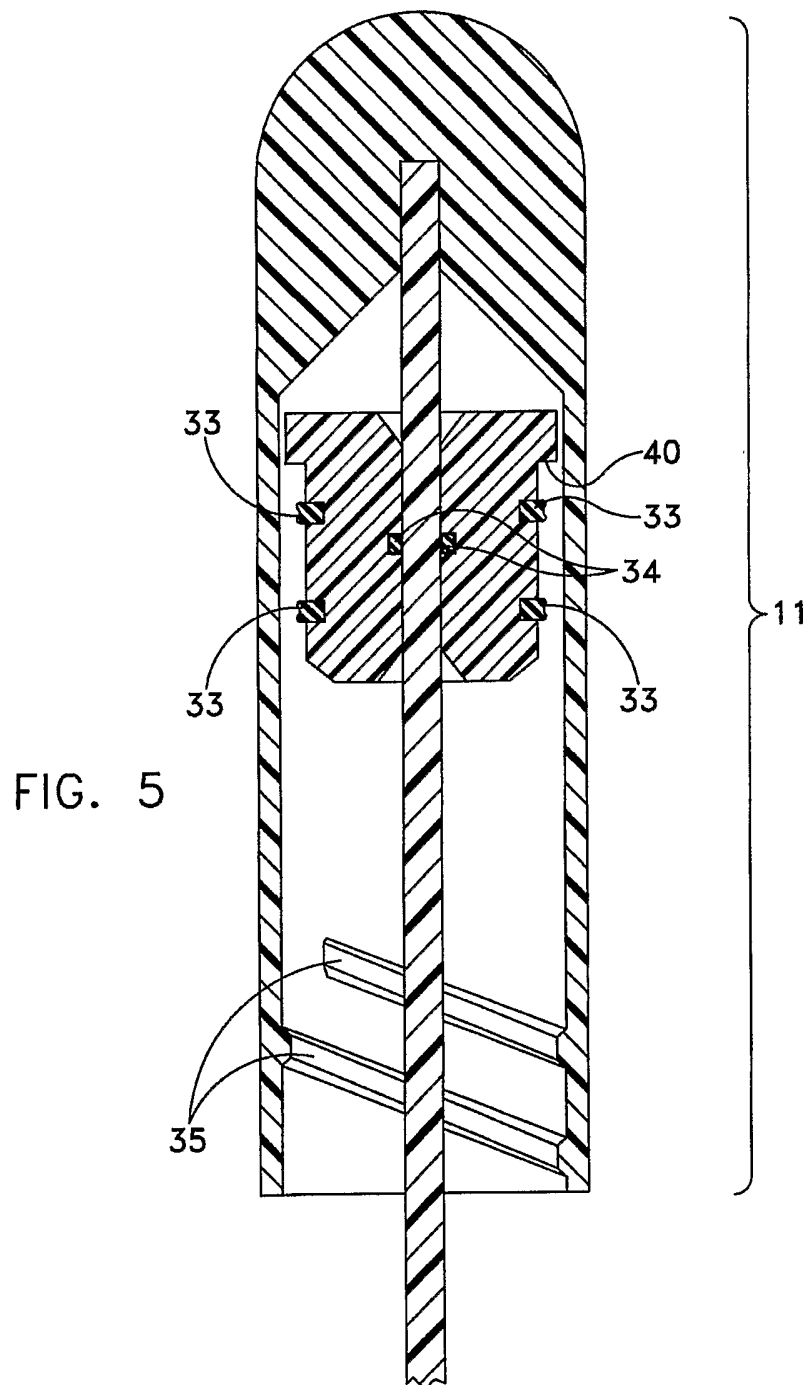

FIG. 4



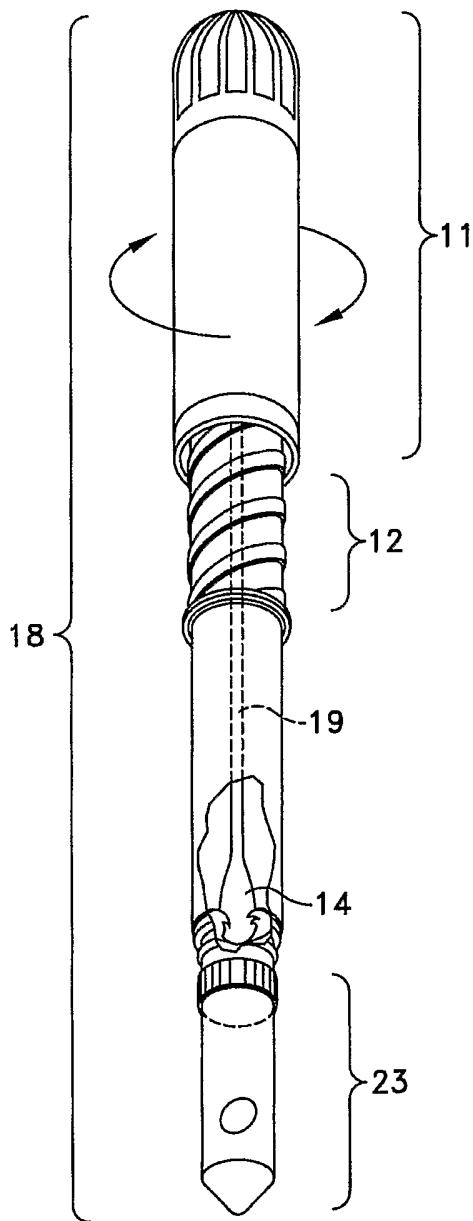

FIG. 6

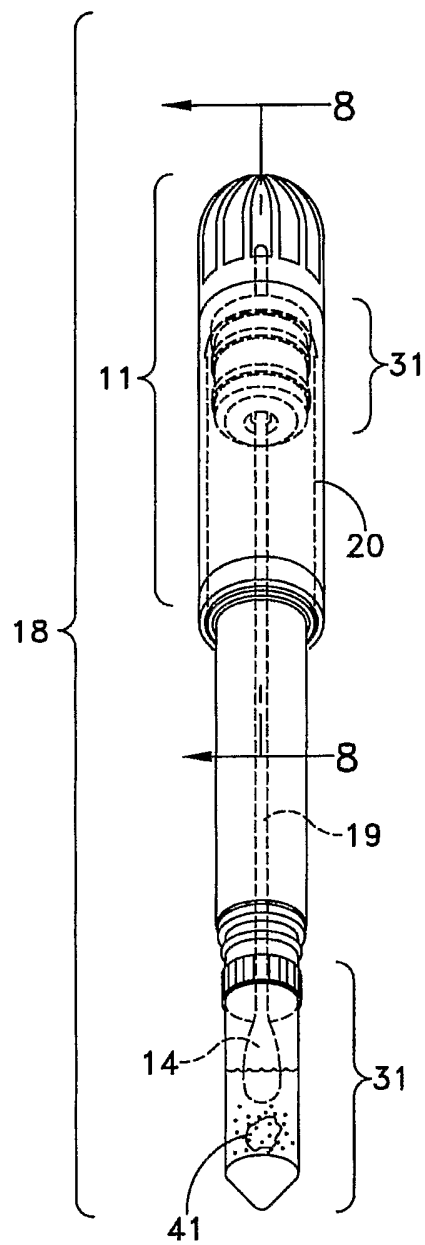

FIG. 7

6/23

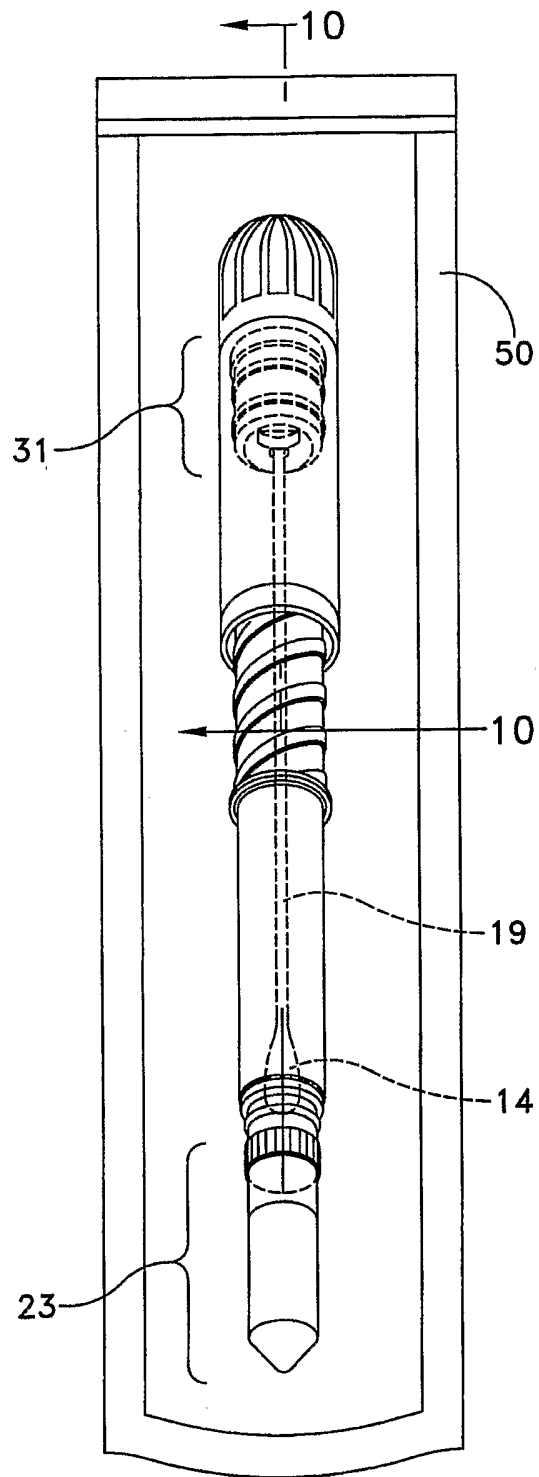

FIG. 9

7/23

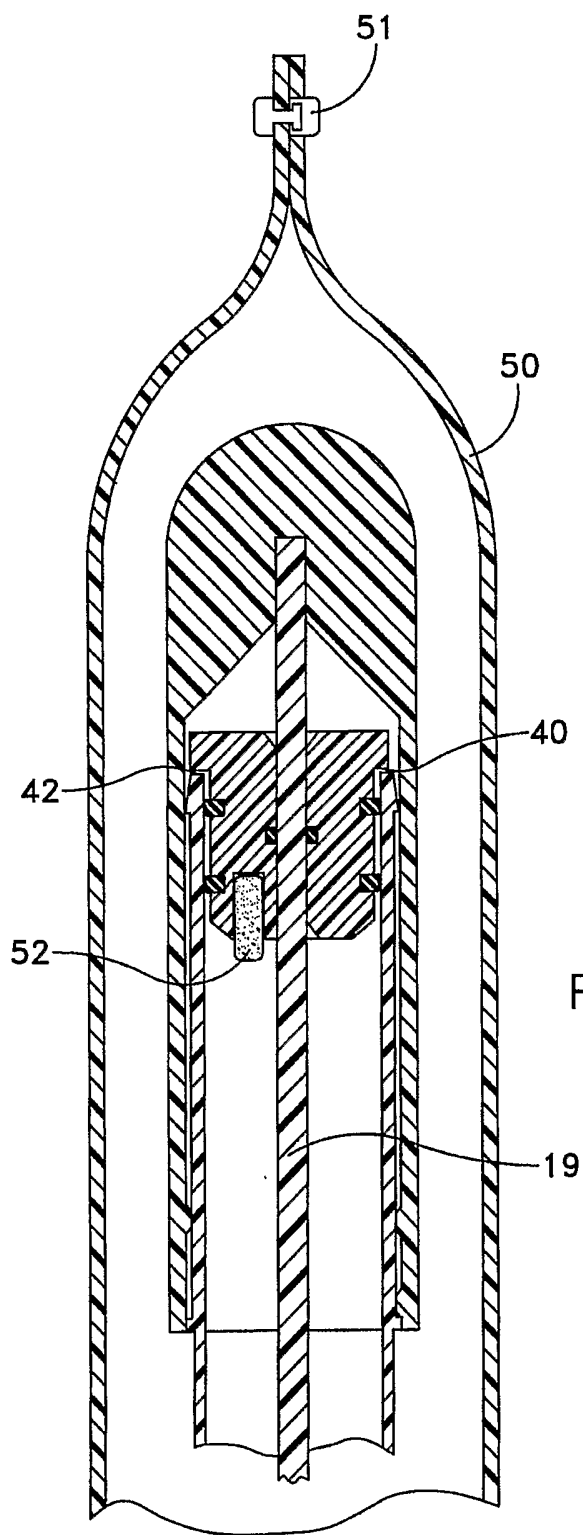

FIG. 10

8/23

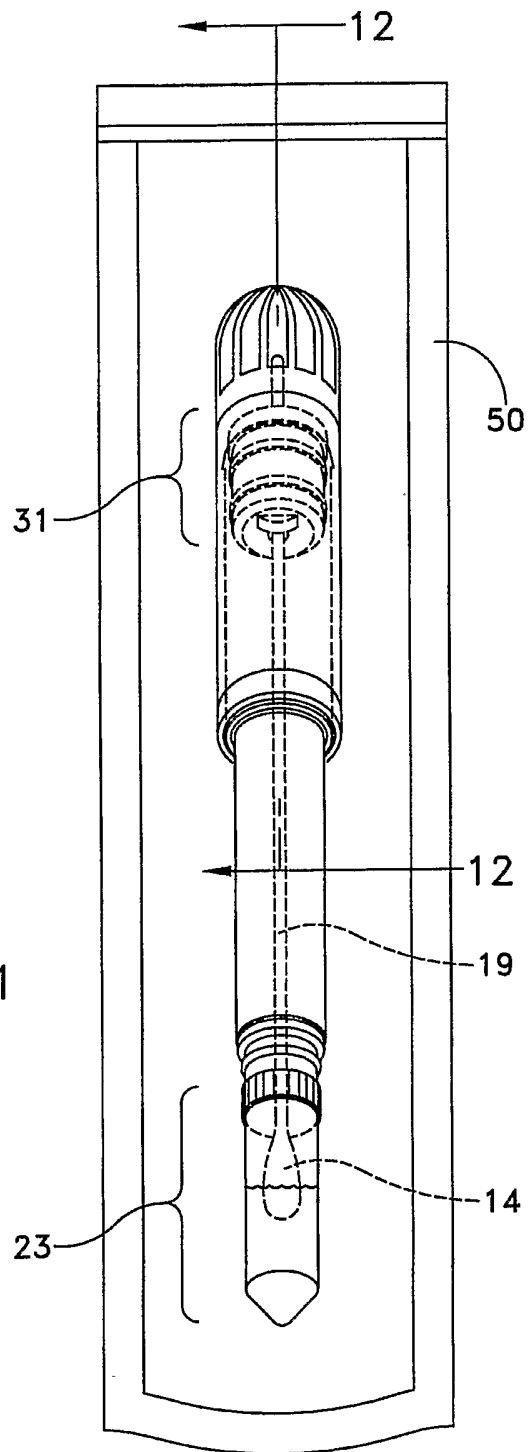
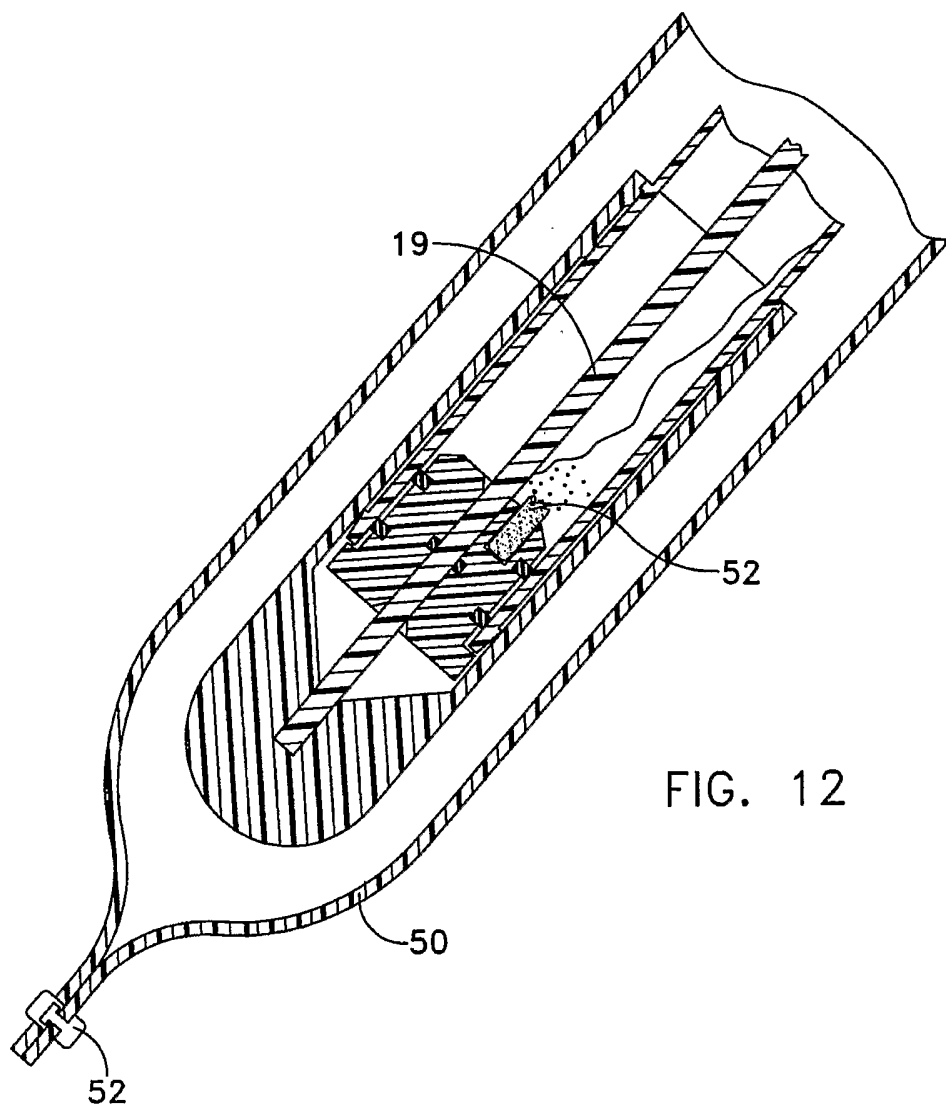

FIG. 11



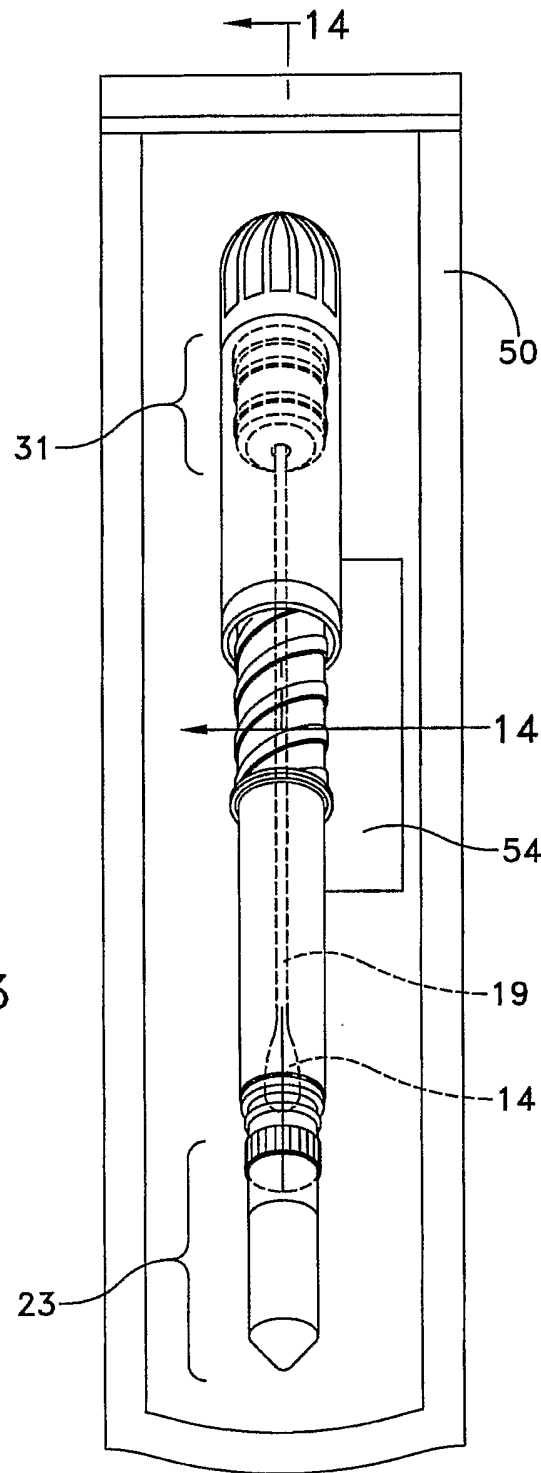

FIG. 13

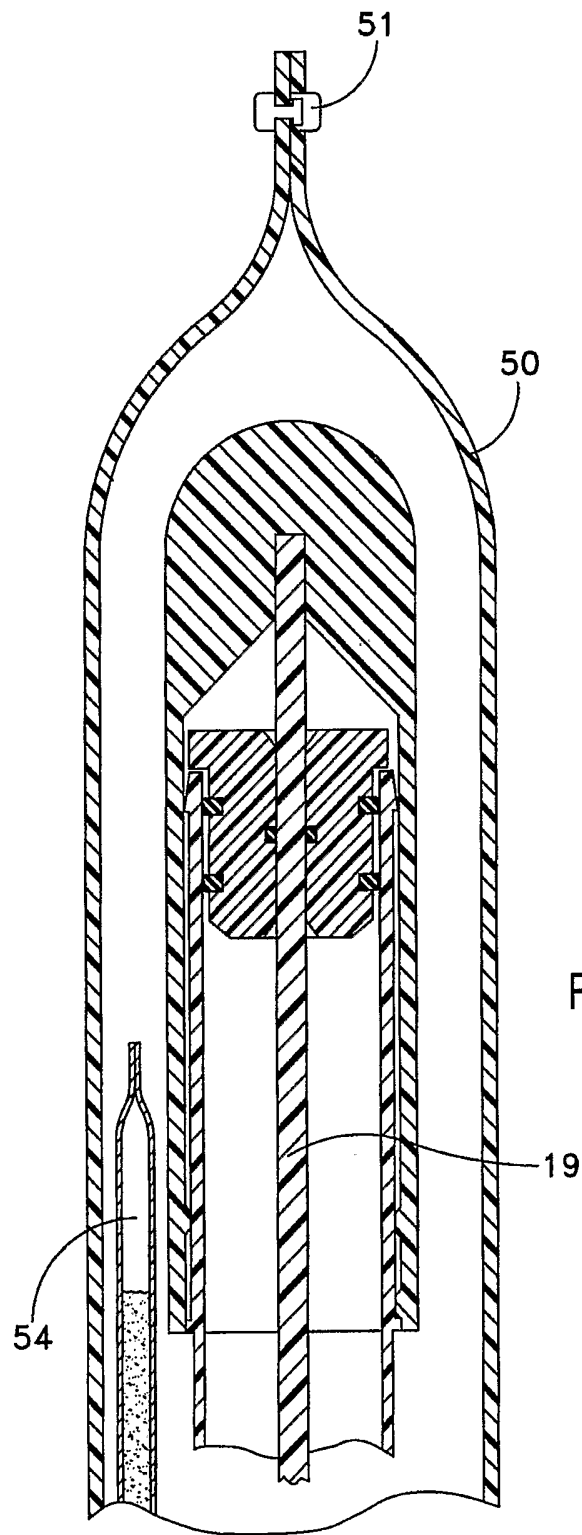

FIG. 14

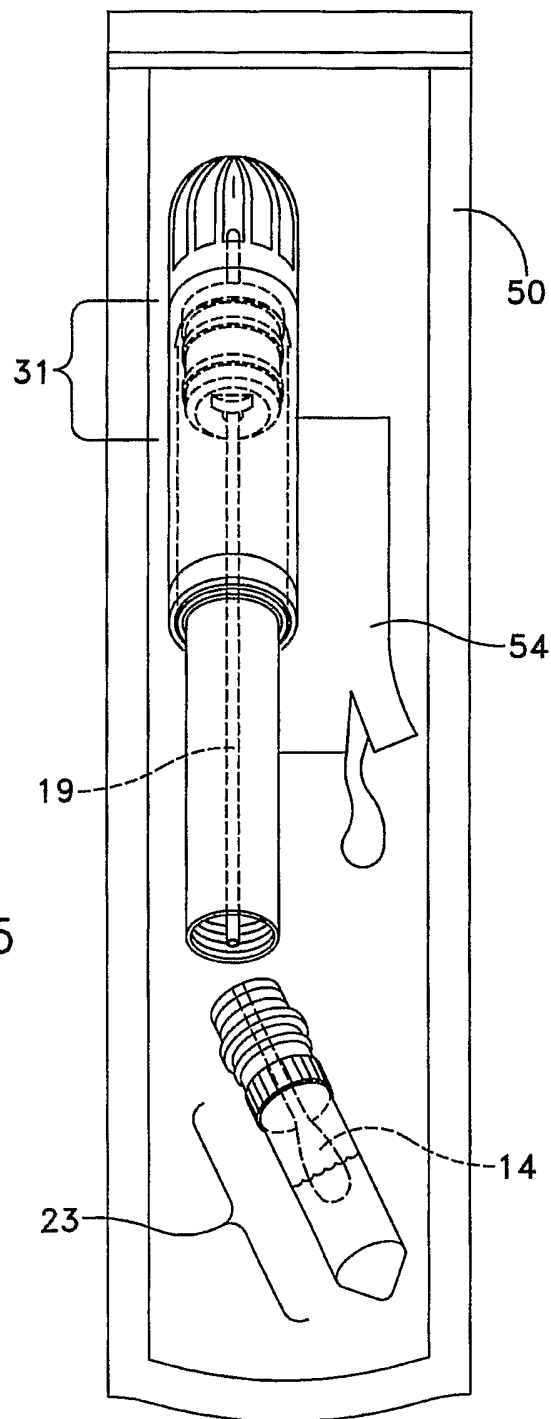

FIG. 15

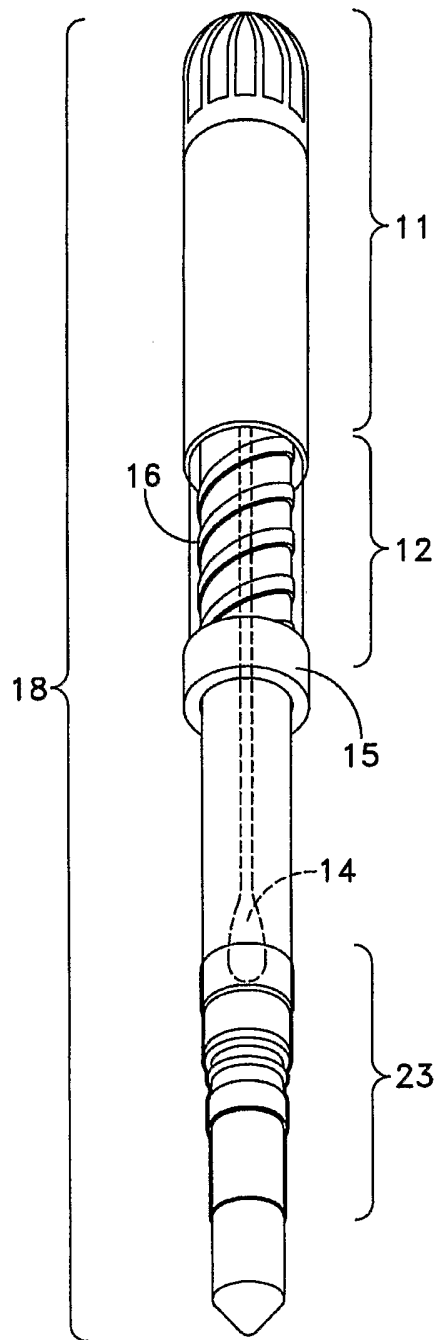

FIG. 16

14/23

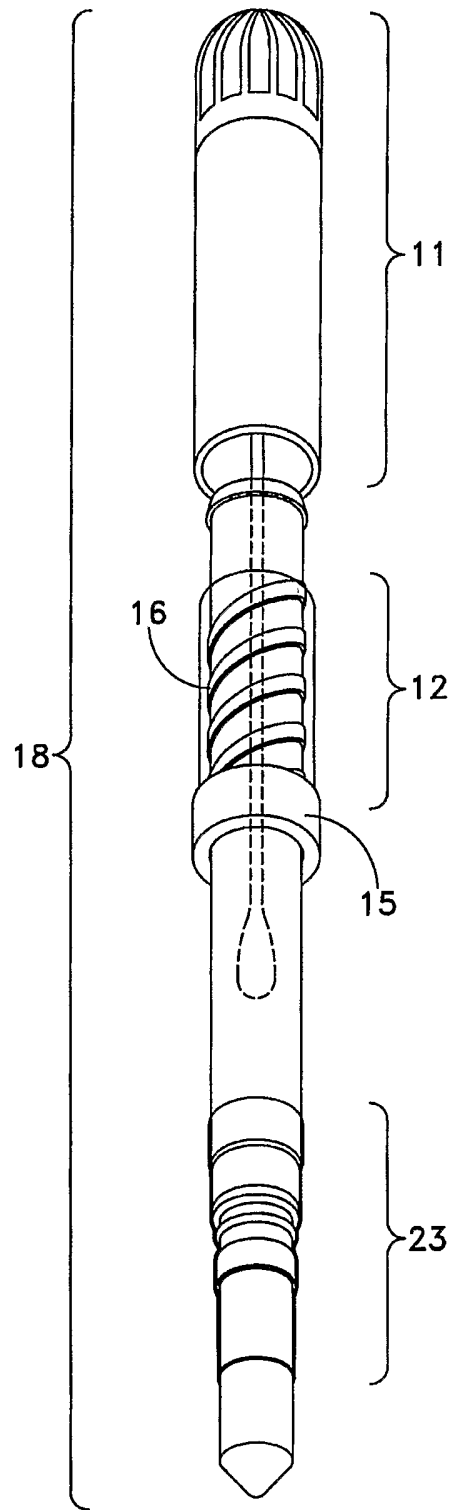

FIG. 17

15/23

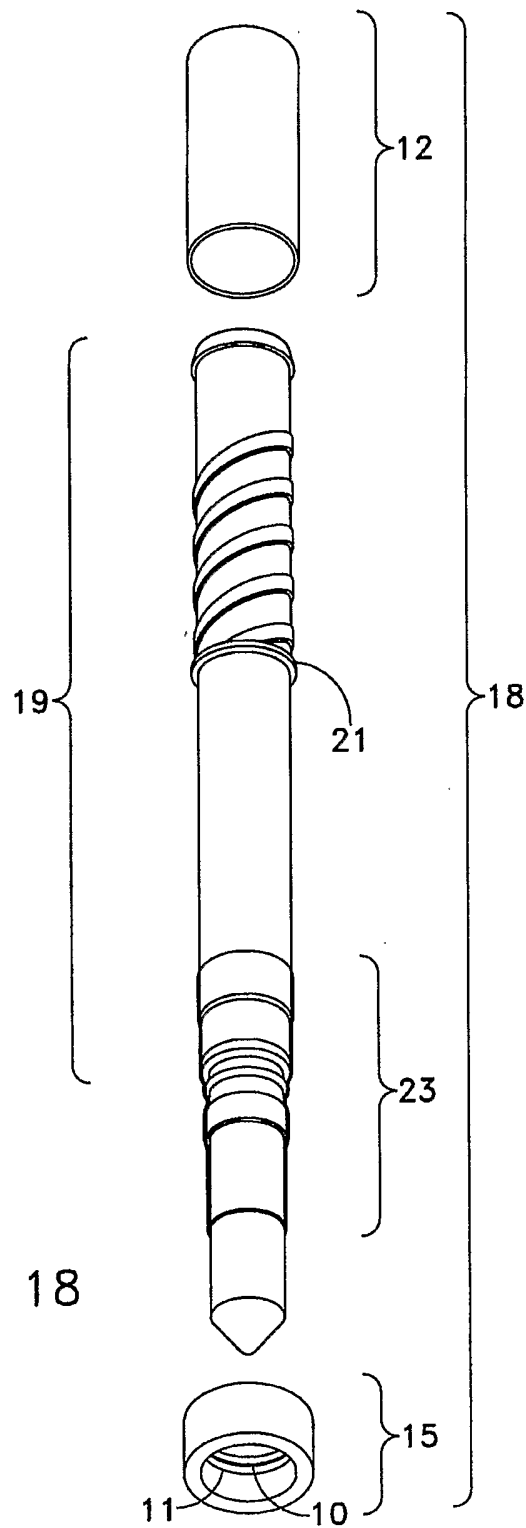

FIG. 18

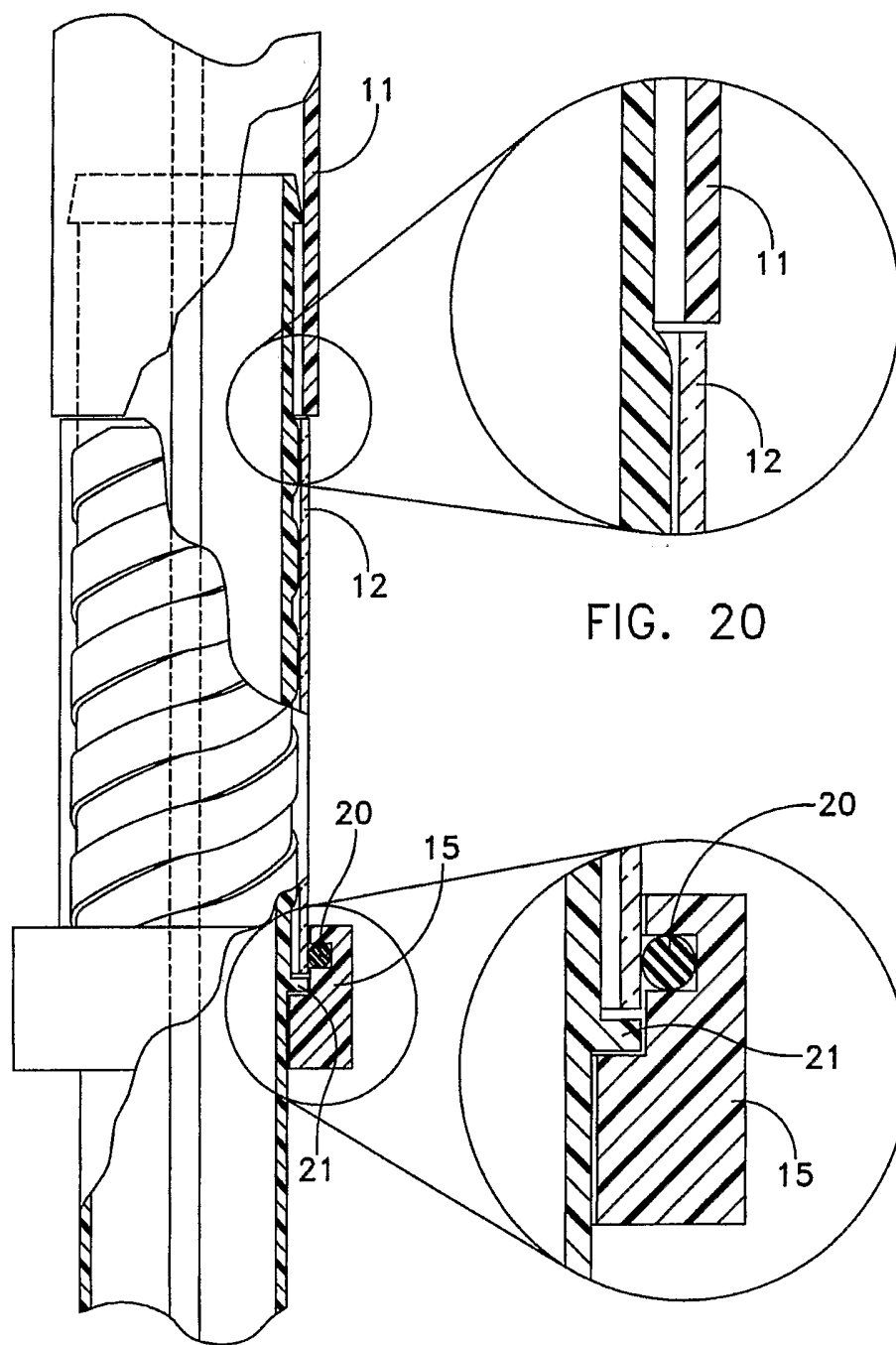

FIG. 19

FIG. 20

FIG. 21

17/23

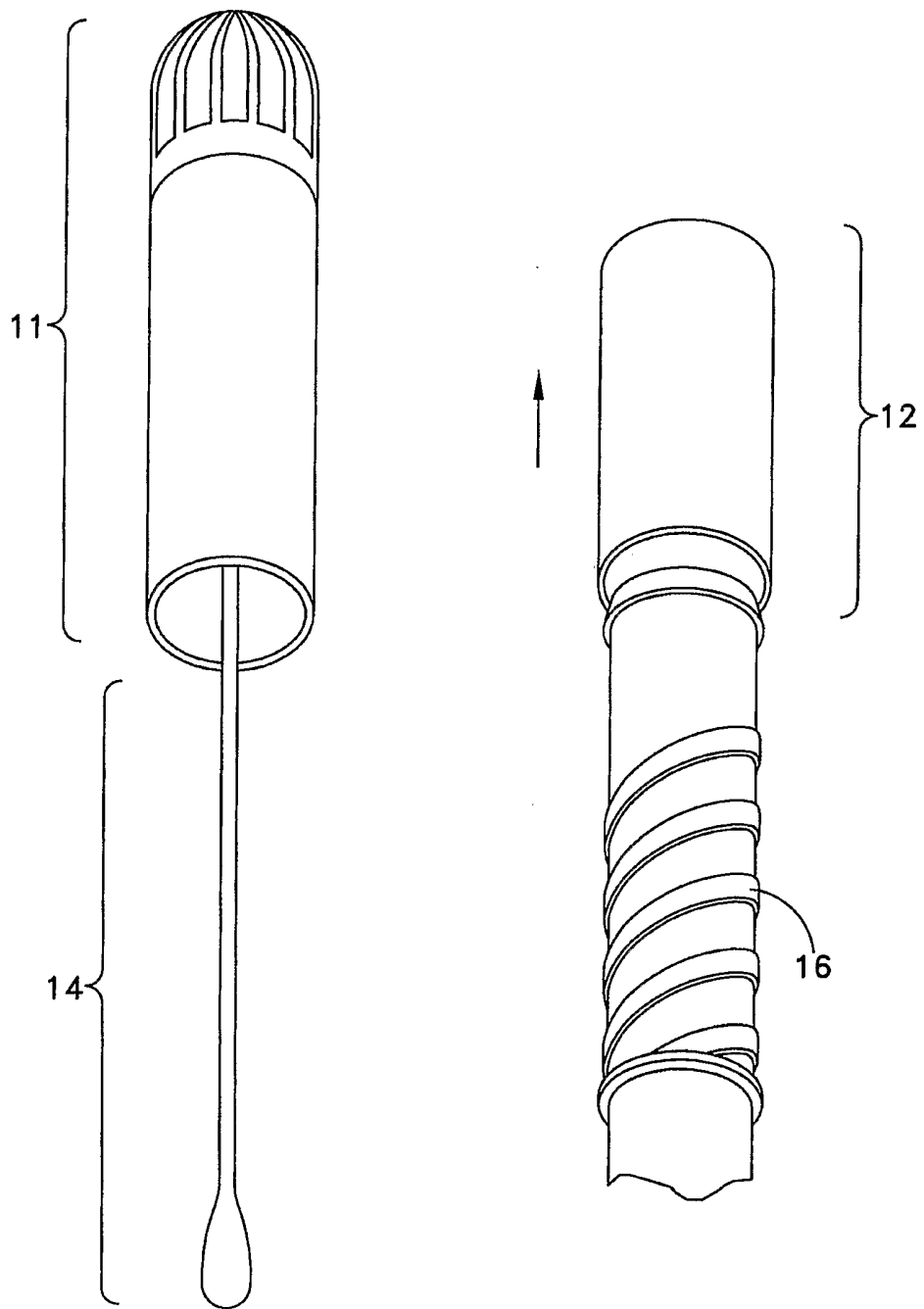

FIG. 22

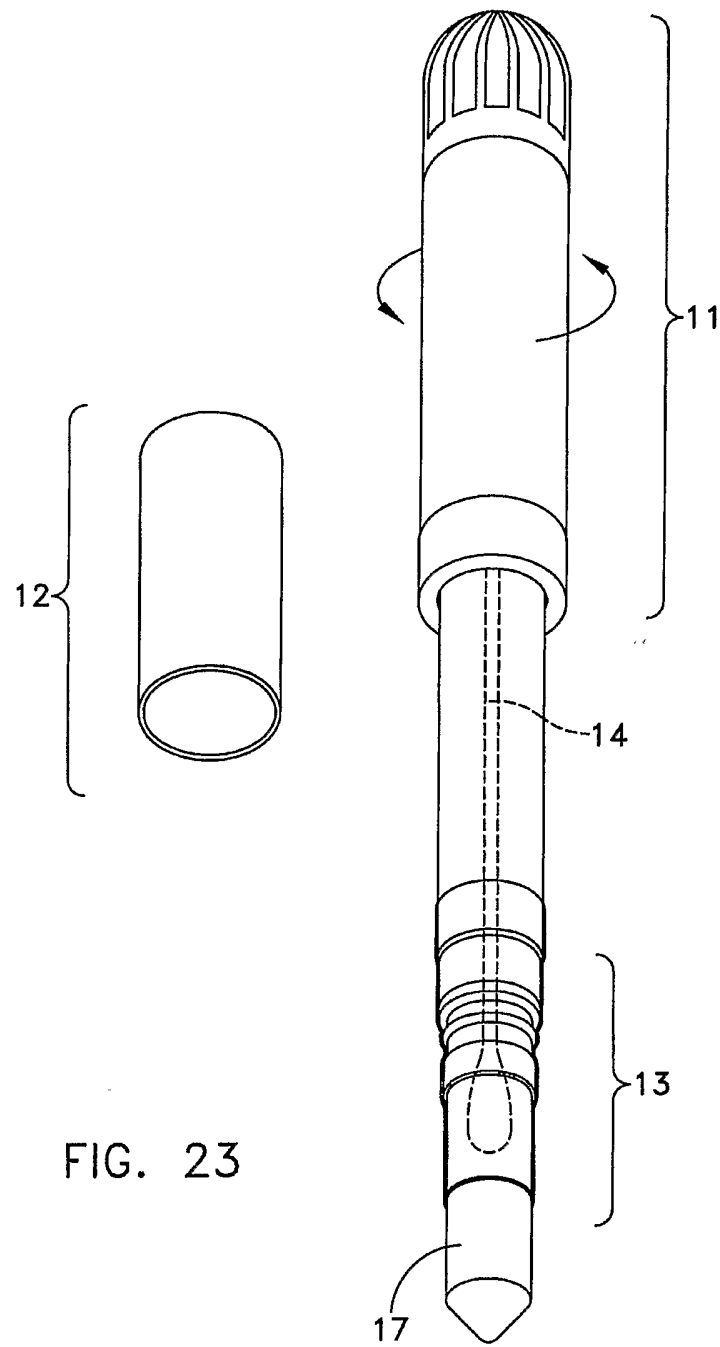

FIG. 23

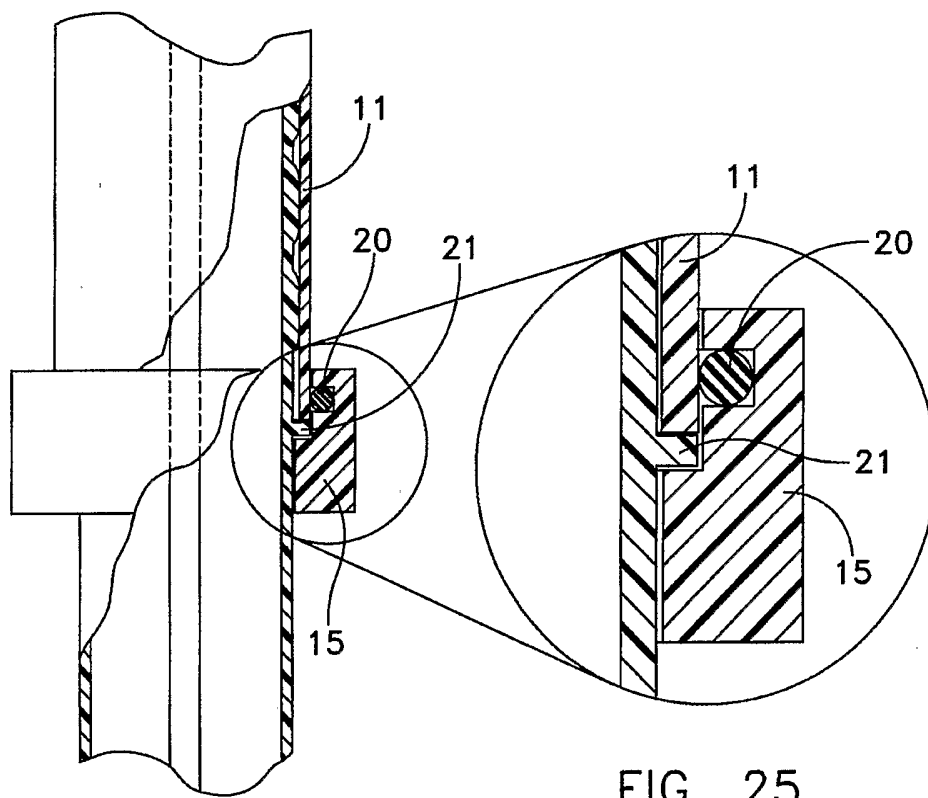

FIG. 24

FIG. 25

20/23

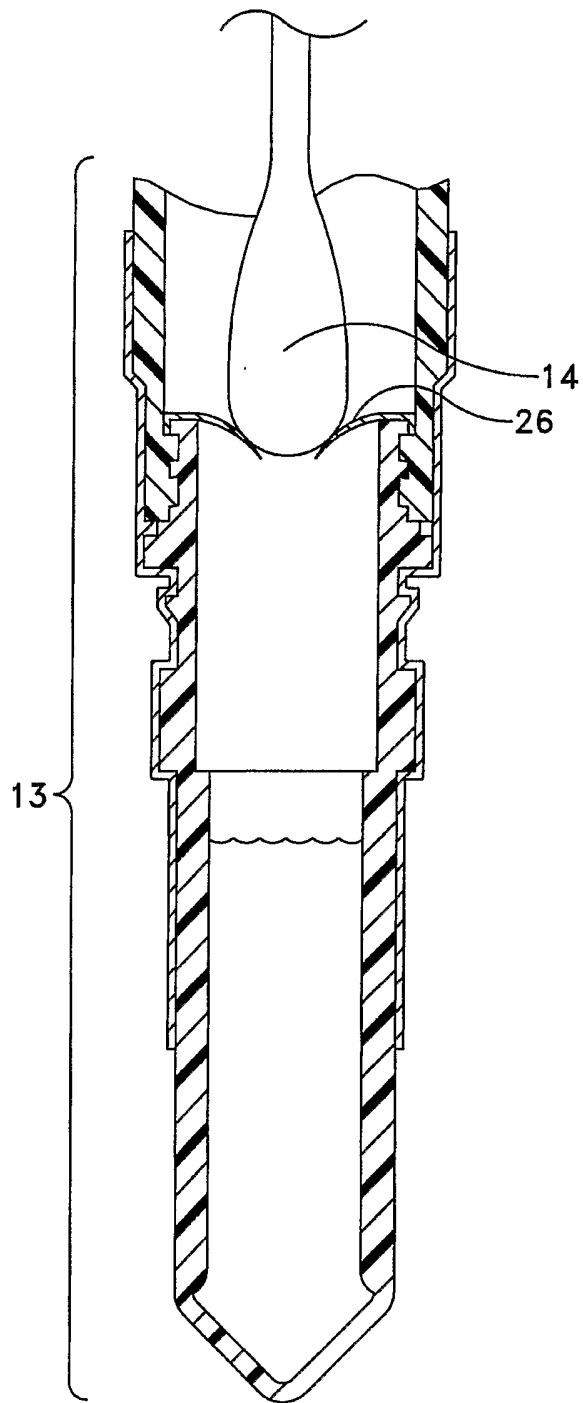

FIG. 26

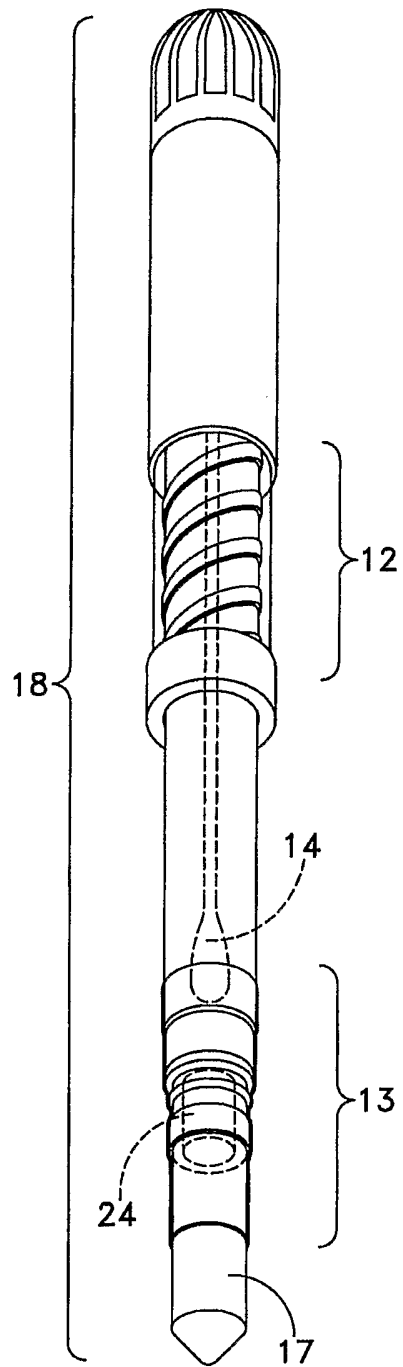

FIG. 27

22/23

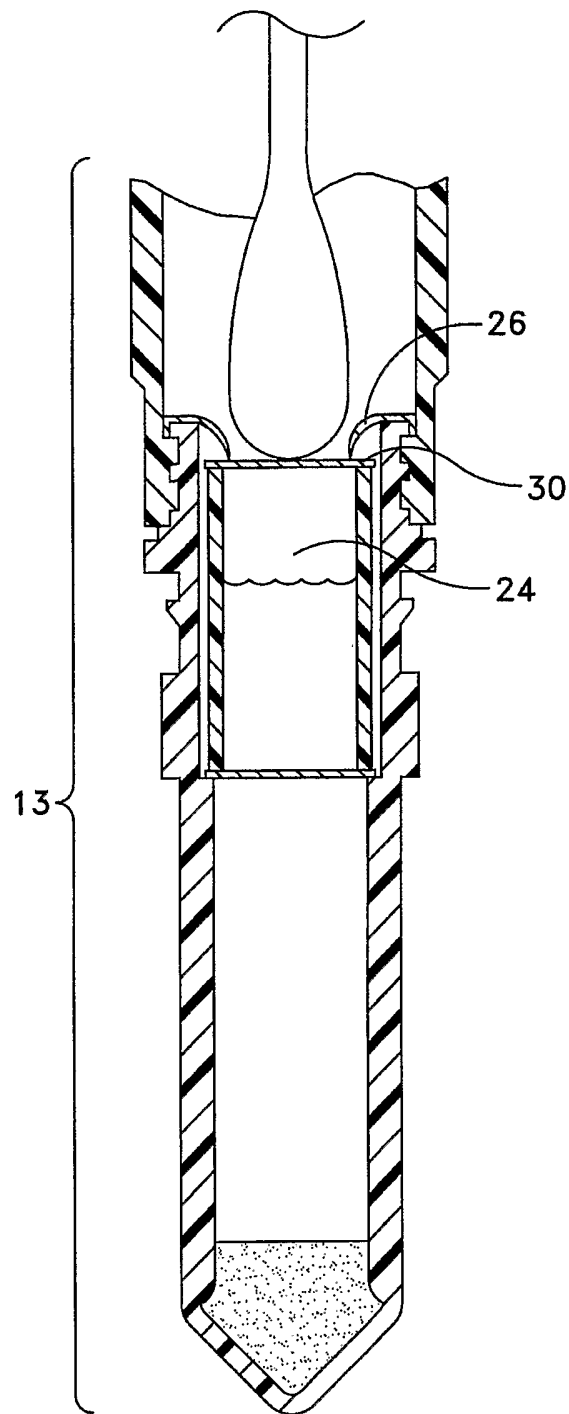

FIG. 28

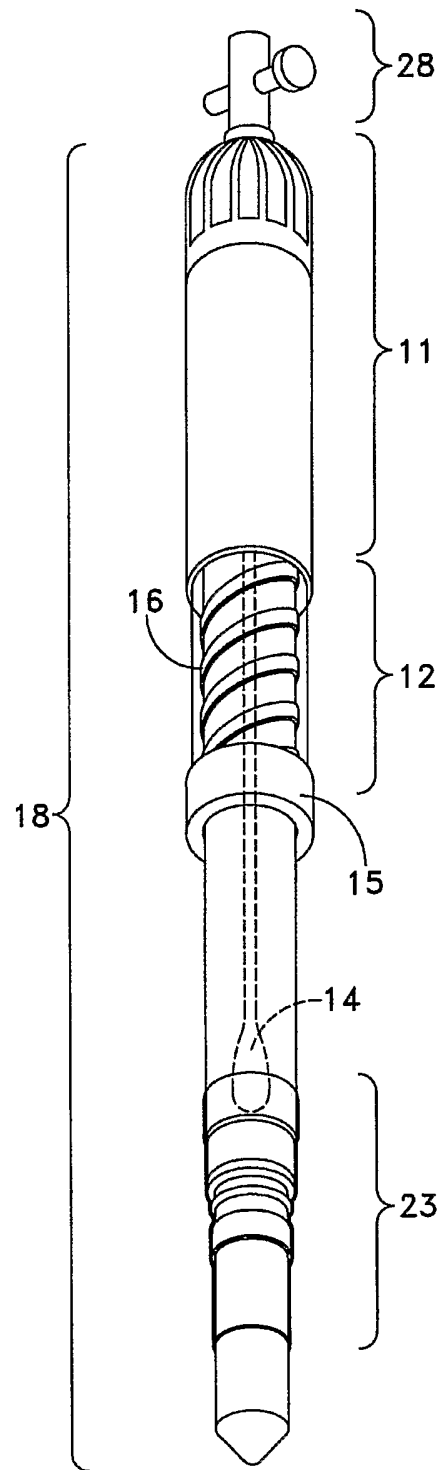

FIG. 29