

US00D394637S

United States Patent [19]

[11] Patent Number: Des. 394,637

Camiano

[45] Date of Patent: **May 26, 1998

[54] GOLF CART ROOF

[75] Inventor: Robert D. Camiano, Phoenix, Ariz.

[73] Assignee: Leading Edge Technologies, Inc., Chandler, Ariz.

[**] Term: 14 Years

[21] Appl. No.: 70,418

[22] Filed: May 7, 1997

[51] LOC (6) Cl. 12-16

[52] U.S. Cl. D12/401; D12/16

[58] Field of Search D12/16, 400, 401; D25/56; 296/210, 216; 280/DIG. 5, DIG. 6

[56] References Cited

U.S. PATENT DOCUMENTS

D. 305,569	1/1990	Walz	D12/401
D. 330,350	10/1992	Maypole	D12/401 X
D. 335,850	5/1993	Cyrson	D12/401
D. 362,423	9/1995	Thomas	D12/401
D. 381,953	8/1997	Collins	D12/401
4,332,415	6/1982	Williams	280/DIG. 5 X
5,094,500	3/1992	Maypole	280/DIG. 5 X

OTHER PUBLICATIONS

Prolink Advertising Brochure circa 1996.

Primary Examiner—Nelson C. Holtje
Attorney, Agent, or Firm—Wigman, Cohen, Leitner & Myers, P.C.

[57] CLAIM

The ornamental design for a golf cart roof, as shown and described.

DESCRIPTION

FIG. 1 is a perspective view of a golf cart showing the new design of the golf cart roof of my invention;

FIG. 2 is a front view of the golf cart roof showing my new design;

FIG. 3 is a rear view of the golf cart roof showing my new design;

FIG. 4 is a top view of the golf cart roof showing my new design;

FIG. 5 is a bottom view of the golf cart roof showing my new design;

FIG. 6 is a side view of the golf cart roof showing my new design;

FIG. 7 is a cross-sectional view taken along line 7—7 of FIG. 4; and,

FIG. 8 is a bottom perspective view of the golf cart roof showing my new design.

The broken line showing of a golf cart is for illustrative purposes only and forms no part of the claimed design.

1 Claim, 4 Drawing Sheets

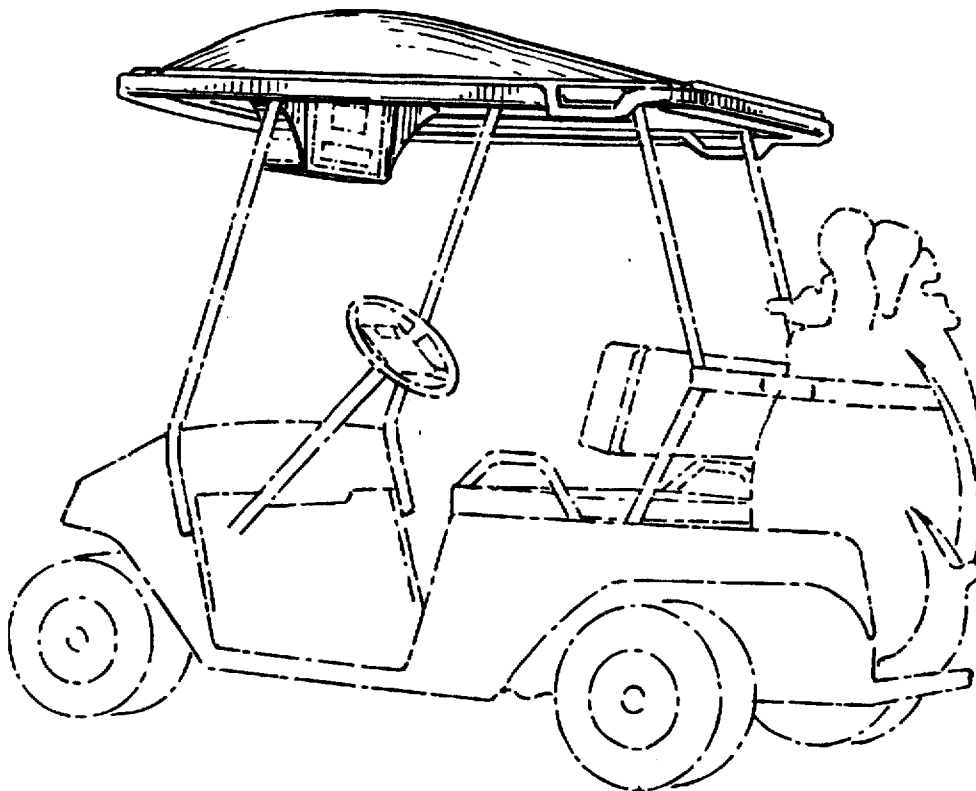

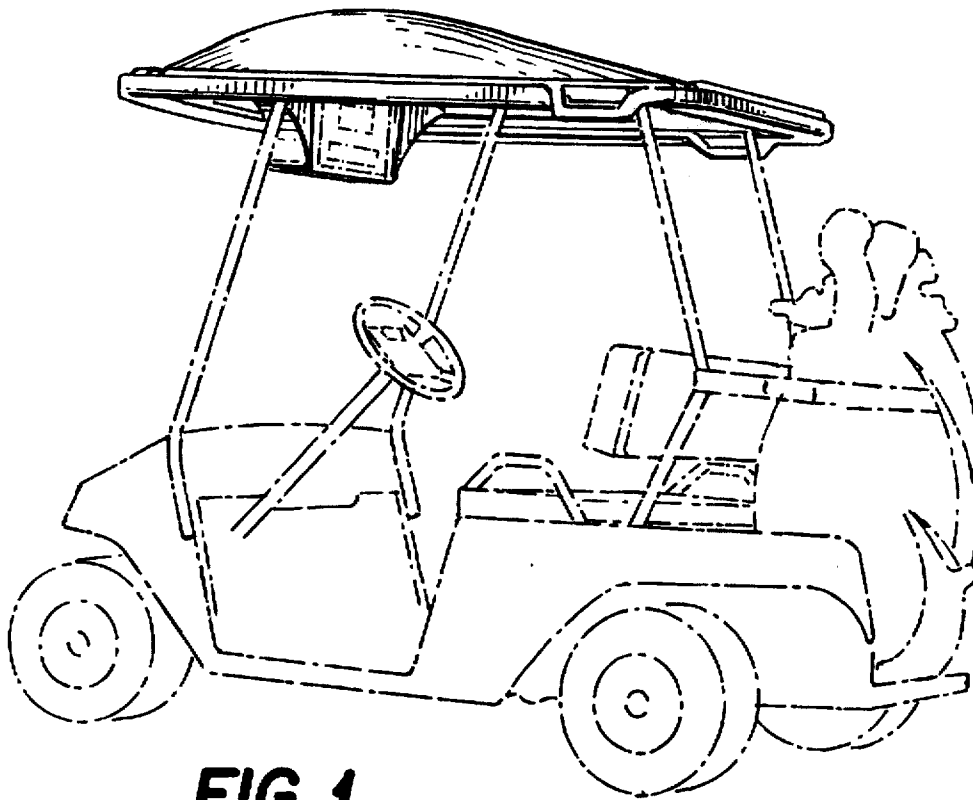

FIG. 1

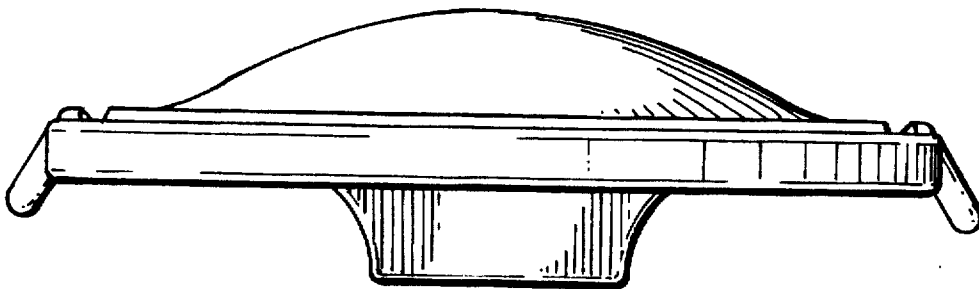

FIG. 2

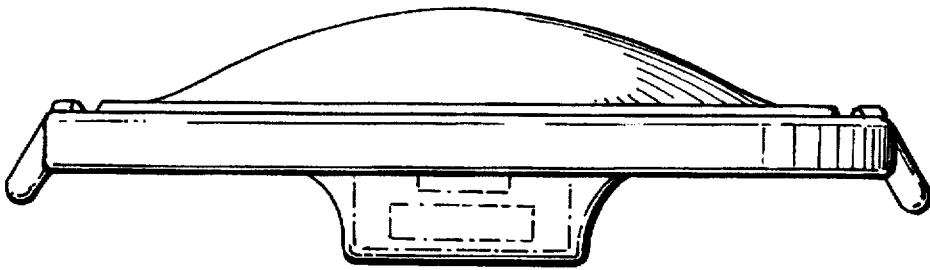

FIG. 3

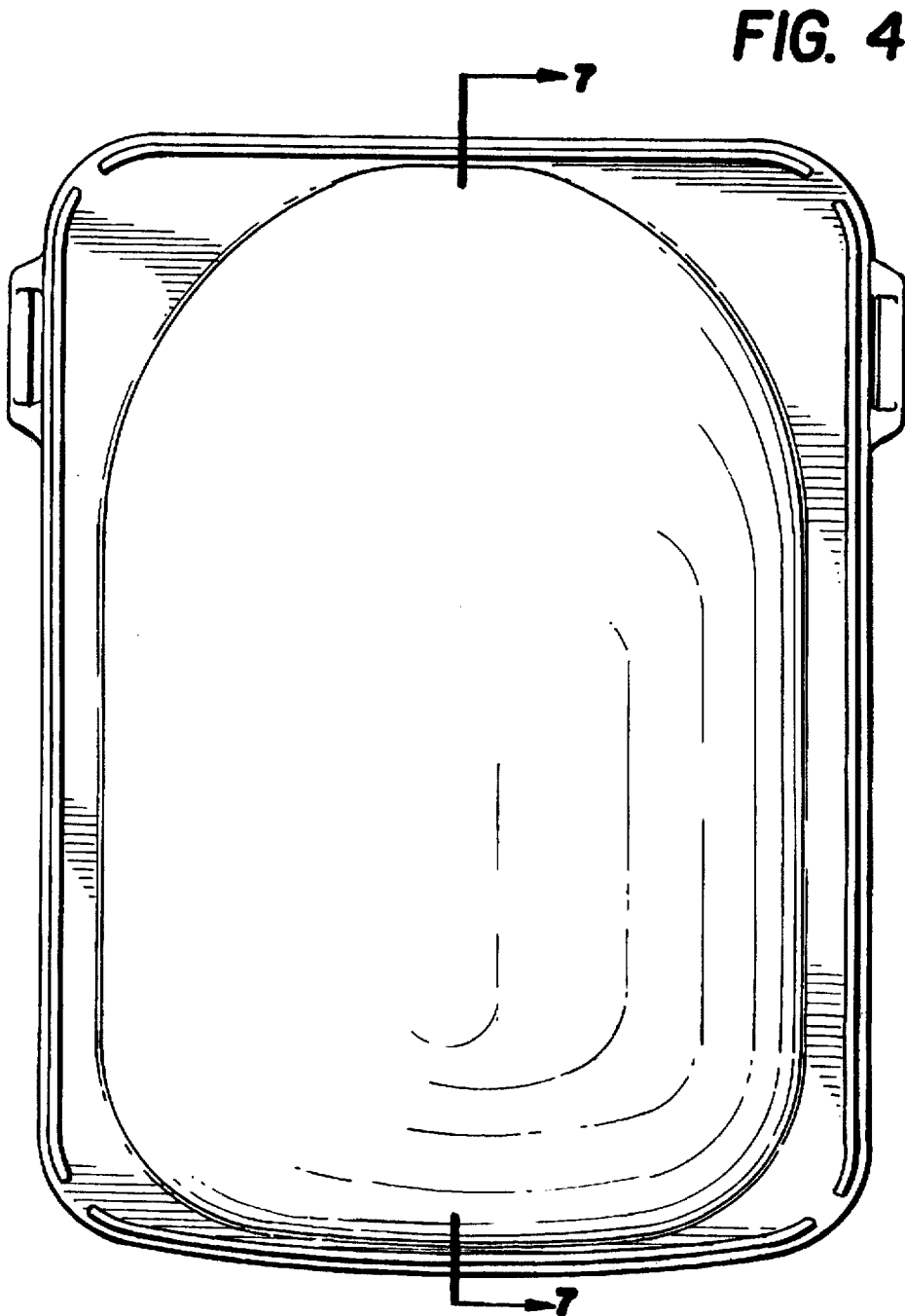

FIG. 4

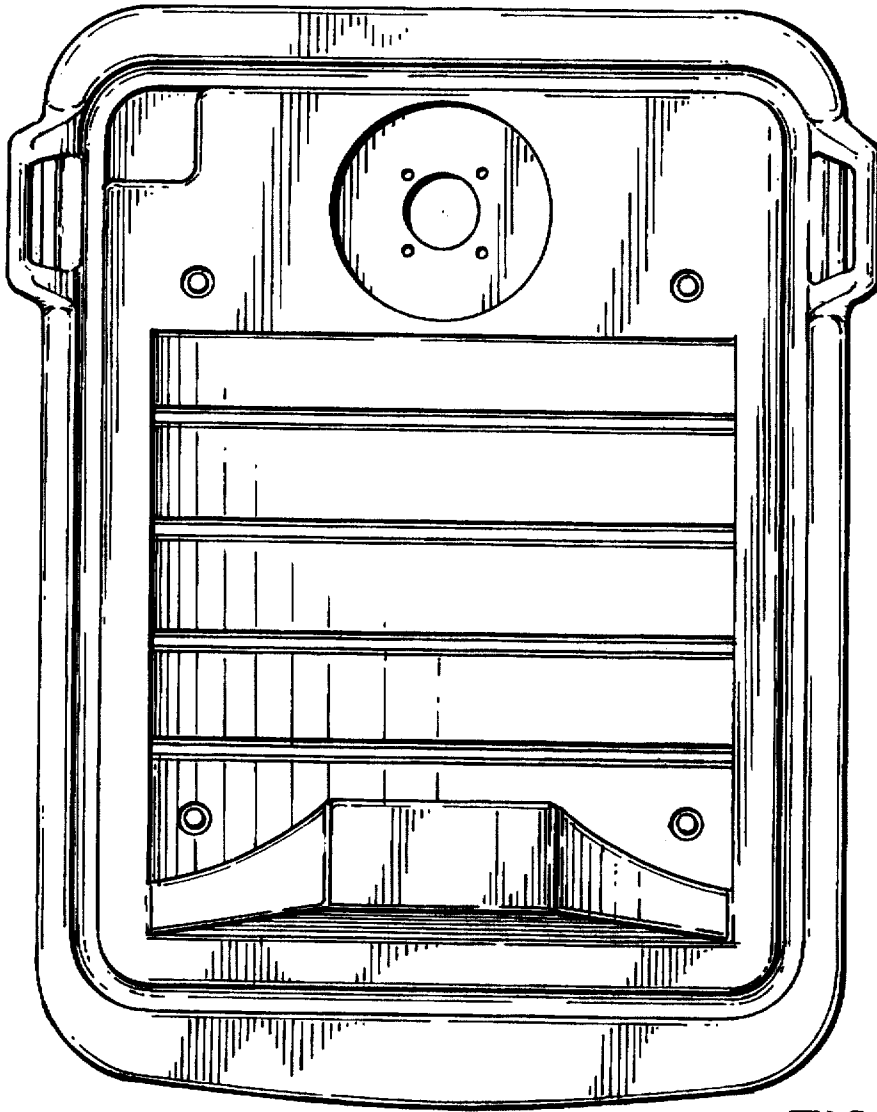

FIG. 5



FIG. 6

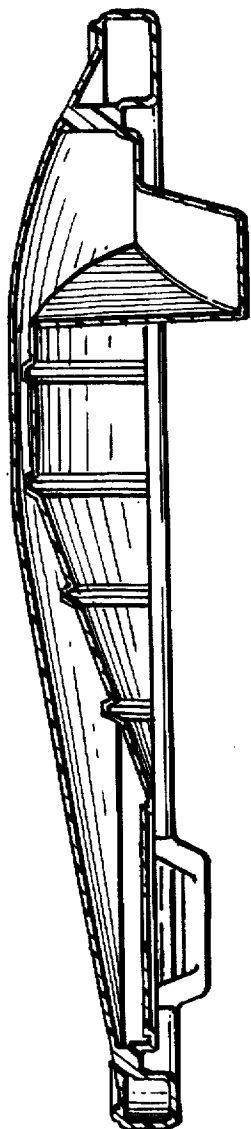

FIG. 7

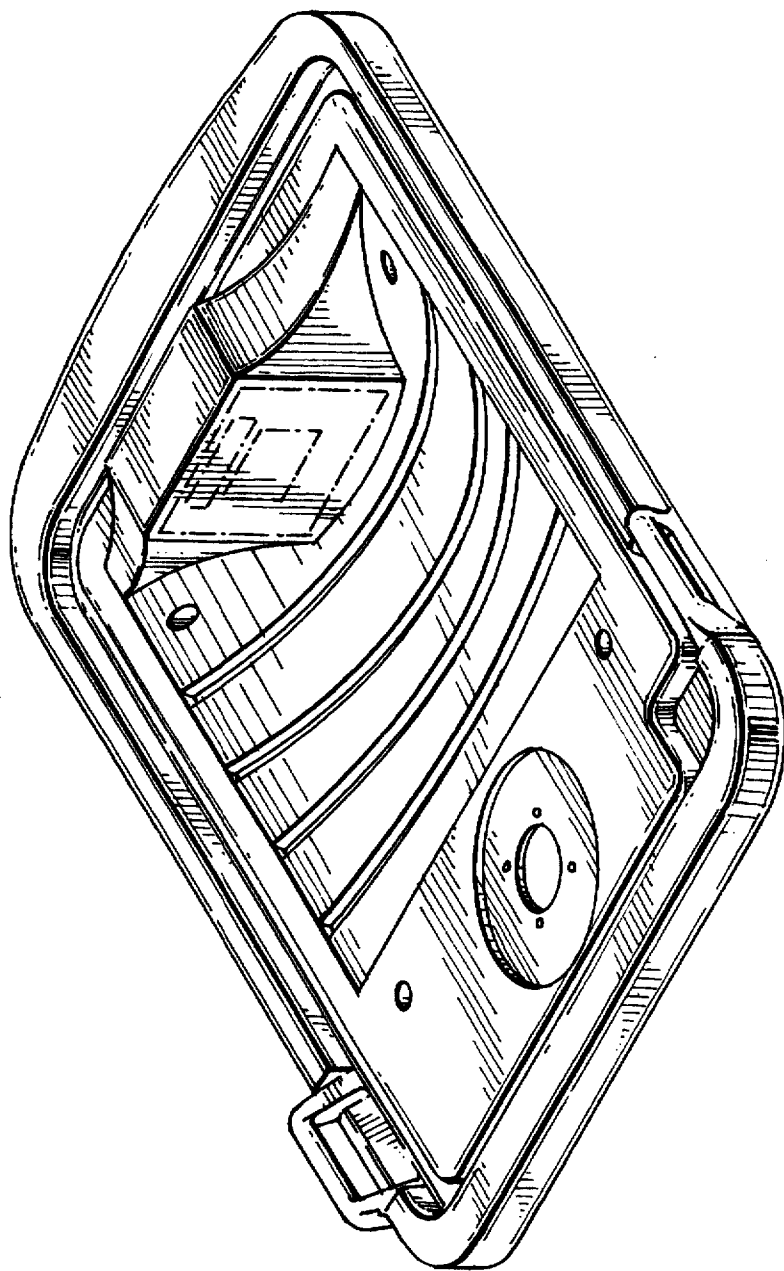

FIG. 8