

(19) World Intellectual Property Organization
International Bureau



(43) International Publication Date
22 December 2011 (22.12.2011)

(10) International Publication Number
WO 2011/159233 A1

- (51) International Patent Classification:
A62B 18/08 (2006.01) B29C 51/10 (2006.01)
A62B 18/02 (2006.01) B29D 11/00 (2006.01)
- (21) International Application Number:
PCT/SE2011/050729
- (22) International Filing Date:
14 June 2011 (14.06.2011)
- (25) Filing Language: English
- (26) Publication Language: English
- (30) Priority Data:
1050629-3 18 June 2010 (18.06.2010) SE
- (71) Applicant (for all designated States except US): **FACE-COVER SWEDEN AB** [SE/SE]; Gulliversvägen 3, S-176 77 Järfälla (SE).
- (72) Inventor; and
- (75) Inventor/Applicant (for US only): **KLOCKSETH, Oliver** [SE/SE]; Kastanjevägen 23, S-175 64 Järfälla (SE).
- (74) Agent: **EHRNER & DELMAR PATENTBYRÅ AB**; PO Box 10316, S-100 55 Stockholm (SE).
- (81) Designated States (unless otherwise indicated, for every kind of national protection available): AE, AG, AL, AM, AO, AT, AU, AZ, BA, BB, BG, BH, BR, BW, BY, BZ, CA, CH, CL, CN, CO, CR, CU, CZ, DE, DK, DM, DO, DZ, EC, EE, EG, ES, FI, GB, GD, GE, GH, GM, GT, HN, HR, HU, ID, IL, IN, IS, JP, KE, KG, KM, KN, KP, KR, KZ, LA, LC, LK, LR, LS, LT, LU, LY, MA, MD, ME, MG, MK, MN, MW, MX, MY, MZ, NA, NG, NI, NO, NZ, OM, PE, PG, PH, PL, PT, RO, RS, RU, SC, SD, SE, SG, SK, SL, SM, ST, SV, SY, TH, TJ, TM, TN, TR, TT, TZ, UA, UG, US, UZ, VC, VN, ZA, ZM, ZW.
- (84) Designated States (unless otherwise indicated, for every kind of regional protection available): ARIPO (BW, GH, GM, KE, LR, LS, MW, MZ, NA, SD, SL, SZ, TZ, UG, ZM, ZW), Eurasian (AM, AZ, BY, KG, KZ, MD, RU, TJ, TM), European (AL, AT, BE, BG, CH, CY, CZ, DE, DK, EE, ES, FI, FR, GB, GR, HR, HU, IE, IS, IT, LT, LU, LV, MC, MK, MT, NL, NO, PL, PT, RO, RS, SE, SI, SK, SM, TR), OAPI (BF, BJ, CF, CG, CI, CM, GA, GN, GQ, GW, ML, MR, NE, SN, TD, TG).

[Continued on next page]

(54) Title: A FULL FACE MASK FOR A PAPR

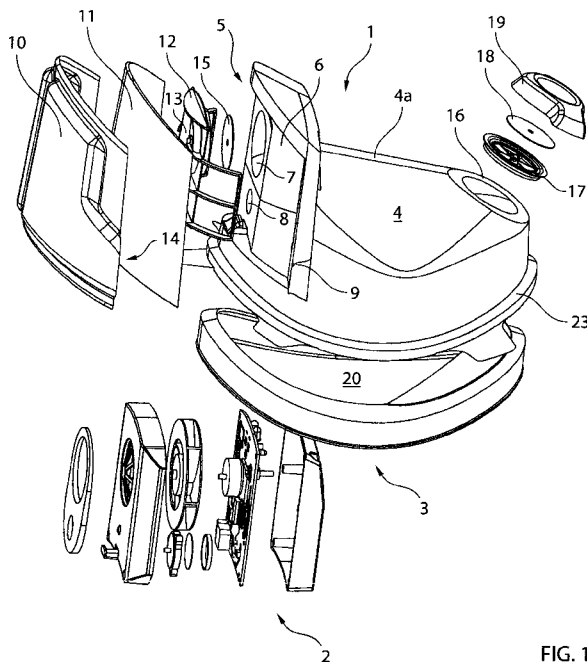

FIG. 1

(57) Abstract: A full face mask (1) for a PAPR (Powered Air Purifying Respirator) to be used in health hazardous environments, having an air inlet (7, 8) and an air outlet (16), manufactured in one piece from a transparent plastic in a one step vacuum forming process with a single curved field of vision (4) exempt from distortions and comprising a compartment (5) inside a forehead area of the full face mask for accommodating a blower unit (2).

WO 2011/159233 A1

Published:

— *with international search report (Art. 21(3))*

A FULL FACE MASK FOR A PAPR**Technical field**

The present invention relates to PAPRs (Powered Air Purifying Respirator), and more specifically a full face mask for PAPRs
5 to be used in health hazardous environments, such as scenes of fire, construction sites, virus containing environments and the like.

Background

For personal protection, hand washing is of course essential,
10 but for health care personal and others subjected to virus containing environments, there are masks and respirators. Facemasks or surgical masks are mostly loose fitting disposable masks stopping droplets and skin or hair particles, and prevent splashes from contacting the face of the wearer,
15 but they are no good for virus protection e.g. because of sealing problems against the face, and a negative pressure inside the mask during inhalation. Respirators, and in this context air-purifying respirators are air filtering devices that protect against inhalation of both large and small
20 particles by removing contaminants by filtration or absorption. They may be passive, APR, or powered, PAPR.

The PAPRs of today have a great advantage over APRs, because they only require a simple fit test, and they do not increase the work of breathing. However, because of growth of beard,
25 wrinkles etc. it is difficult to obtain a perfect sealing against the face. These problems are set aside by providing a positive pressure inside the face mask. However, there are also a number of disadvantages with today's PAPRs, they require special training to put on, to use safely and to take

off; fan noise impedes conversation; it is difficult to use a stethoscope. They may cause claustrophobia.

Made of thick rubber or other sound restricting material, they make conversation difficult and therefore require special
5 amplifiers or speech diaphragms, and telephone conversation is virtually impossible.

Another great disadvantage is that it is very difficult to see were you put your feet because of the restricted field of vision when looking down, especially when remounting a
10 staircase.

Still another disadvantage is that the weight of existing PAPRs is considerable, causing a lot of strain on the neck, and they are therefore quit uncomfortable for a normal human being, such as nurses, doctors, etc.

15 Therefore, there is a great need of improvements of existing PAPRs. Also in other areas there is always a need for comfortable easy-to-use safety equipment with improved performance.

The invention

20 One object of the invention is to provide a full face mask for a PAPR which is easy to use and comfortable to wear, and does not interfere with the use of other equipment.

Another object of the invention is to provide a method for the manufacture of a full face mask for a PAPR with a perfectly
25 clear field of vision.

A further object of the invention is to provide a disposable full face mask for a PAPR.

A further object of the invention is to provide a blower unit giving rise to a minimum of fan noise and with the ability to control the pressure inside a full face mask, and preferably to maintain a positive pressure inside the mask.

5 A further object of the invention is to provide a full face mask for a PAPR capable of housing a blower unit inside the full face mask to be protected from the environment and eliminating ducting and flow losses, and being reusable with its own rechargeable battery but with the option to use an
10 external battery connected through a wire.

A further object of the invention is to provide a full face mask with integrated filter, preferably an electrostatic filter for minimizing the flow resistance.

15 These and other objects of the invention are attained with the PAPR according to the present invention as it is defined in claim 1.

Preferred embodiments and developments of the invention are made the object of sub claims.

Short description of the drawings

20 The invention will be explained more in detail in the following description of embodiments of the invention shown in the drawings, on which

Fig. 1 shows schematically an exploded view of the PAPR according to the invention,

25 Fig. 2 shows schematically a view from behind of the face mask with the blower unit separated from the face mask,

Fig. 3 shows a view corresponding to Fig. 2 with the blower unit installed in the face mask,

Fig. 4 shows a schematic exploded view of the blower unit in enlarged scale,

Fig. 5 shows an alternative embodiment of a gasket for the full face mask comprising an inner mask,

5 Fig. 6 shows a further embodiment of the face mask according to the invention with integrated sealing rim and with a separate harness,

Fig. 6a shows a cross sectional view of the integrated rim in an enlarged scale, and

10 Fig. 7 shows a view corresponding to Fig. 6 with the full face mask inserted in the harness

.

Detailed description of preferred embodiments

15 In Fig. 1 a schematic exploded view of a PAPR incorporating one embodiment of the full face mask according to the invention. The full face mask 1 is shown to the right and a blower unit 2 to the left. According to this embodiment a face seal 3 is provided for sealing off the interior of the full face mask against the face.

20 The full face mask 1 is manufactured in one piece preferably from PET (polyethylene terephthalate) by vacuum forming. Although PET is a preferred plastic material because of its properties, other plastic materials can be used as well. The field of vision 4 is a single curved surface, the foremost
25 part of which is indicated with a line 4a.

According to the invention, the field of vision is clear and devoid of any distorted areas, which is accomplished by manufacturing the full face mask from a transparent plastic in

one piece in a vacuum forming process, in which method a plastic film or sheet is heated, while heat is prevented from reaching an area corresponding to a field of vision of the full face mask. During the vacuum forming process the field of vision is given a single curved form by suction towards a forming surface, and when the heated parts of the plastic after being vacuum formed have cooled, they will maintain the desired form of the field of vision, which will be perfectly clear with a perfect visibility without any distortions.

10 In the forehead area there is a compartment 5 for accommodating the blower unit 2, which compartment is open towards the interior of the face mask as is clearly shown in Fig. 2. This compartment 5 forms a protrusion, with an upper wall 6 extending substantially perpendicular to the face mask.

15 In the upper wall of the compartment two openings 7, 8, Fig. 1, are arranged, the function of which will be explained below. Further, the upper wall is designed with a rim 9. A filter unit is formed with an outer wall element 10 to be bonded to said rim. In the resulting chamber a filter element

20 11 is be encased. Between the filter and the upper wall of the blower unit compartment is arranged a support 12 for the filter acting as a spacer. A valve seat 13 can be integrated with the support, as is illustrated in Fig. 1.

At present, the placement of the blower unit in a chamber in the forehead area of the full face mask is preferred, but as is obvious, a compartment for the blower unit could be place in another part of the full face mask.

The outer wall element 10 has air inlet openings 14, which should be designed to prevent entrance of contaminants into the filter compartment. For example, it might be necessary to

shower when wearing the face mask, or if used outside it might be raining.

The filter element 11 is preferably an electrostatic filter, which has a low flow resistance. A suitable electrostatic
5 filter material is MES from Munktell Filter AB, Sweden. However, the filter element can also be a HEPA filter, a carbon filter or any combination of electrostatic filter, HEPA filter and carbon filter.

According to one embodiment of the invention a one-way valve
10 is arranged in the opening 7 between blower unit compartment and filter unit with a flexible diaphragm 15, made of e.g. rubber or a material having properties corresponding to rubber. This is a reliable and inexpensive solution. If a more linear action is desired a valve working with a spring loaded
15 sealing member can be used.

In the area of the face mask in the vicinity of the mouth the air outlet 16 is arranged. In the illustrated embodiment an exhalation valve is arranged in the air outlet in the form of a one-way valve having a valve seat 17 and a flexible or
20 spring-loaded diaphragm 18 opening during exhalation, and closing during inhalation. A housing 19 is arranged on the outside of the valve, with air outlet openings. The volume of the housing should be sufficient to create a volume of exhalation air outside the valve which will prevent
25 surrounding air from entering the valve during the time it takes for it to close when a person using the PAPR stops exhaling and begins inhaling.

The sealing 3 sealing the full face mask 1 against the face of a wearer is preferably also vacuum formed in one piece. It is
30 then cut or stamped to have a central opening 20 adapted to the full face mask. The sealing is designed with a form

adapted to the form of the face mask having a rim 21 lying adjacent to the inner sides of the full face mask, and also having a fold 22 in order to abut the rim 23 of the full face mask thereby creating double sealing surfaces against the face of the wearer. The sealing is preferably made of polyethylene.

Flaps 24 are arranged around the perimeter of the face mask for strapping the face mask over the face with the straps meeting at the back of a wearer's head. As is conventional, a wearer will be able to adjust the straps so that the face mask feels comfortable to wear while at the same time a sufficient pressure is exerted on the sealing to obtain the sealing effect between the interior of the full face mask and the surroundings. Other arrangements are of course also possible.

In Fig. 2 a gasket 25 is arranged around the openings in the upper wall of the compartment 5 for sealing against the blower unit 2 and the blower unit is shown in its assembled state. A snap hook element 26 is arranged at one end of the blower unit facing a wearer, which detachably locks the blower unit in the face mask in a corresponding seat 27 in the face mask. The extension of the snap hook element is adapted so that, when the blower unit is locked in the full face mask, a sufficient pressure is exerted on the gasket 25 to obtain a desired sealing effect around the openings in the upper wall of the blower unit compartment.

Fig. 3 illustrates the blower unit 2 installed in its compartment 5 in the full face mask and with the face mask sealing 3 preferably permanently bonded to the face mask.

In Fig. 4 an exploded view of the blower unit according to the invention is shown. It comprises a housing with a lower part 28 and an upper part 29. Electronic components are arranged on a printed circuit card 30, which, when the blower unit is

assembled, will lie in the middle of the housing formed by the lower and upper part of the housing, creating two compartments.

In the lower compartment 31 underneath the printed circuit card there is space for a rechargeable battery, and also for further operative functions. As is schematically shown in the front end of the lower housing part a diaphragm push button 32 is arranged in the wall as well as contact elements 33 to be connected to the printed circuit card. Such push buttons can be operated by pressing them through the lower blower unit compartment wall of the face mask. In a preferred embodiment of the invention, one push button operate the start/stop function of the blower motor, another push button operates a LED light arranged at the front end of the blower unit. Further, although not shown in Fig. 4. LED indicator lamps are preferably arranged in the lower wall of the housing for indicating e.g. that the blower is running, the remaining capacity of the rechargeable battery, that a predetermined pressure prevails in the face mask, etc. Further, a connector for connection of an external battery through a wire can be arranged in a compartment wall, making it possible to change batteries without taking of the face mask.

In the upper part of the housing, the functional parts of the blower unit are arranged. The electronic circuits being known *per se* will not be described in detail. A battery powered motor 34 drives a fan wheel 35. In the embodiment shown on the drawings the fan wheel has an axial inlet 36 and radial outlets 37, but other designs are also possible. Filtered air is drawn by the fan wheel through an opening 38 in the upper part of the blower unit housing and through the opening in the upper wall of the blower unit compartment from the filter unit.

In order to maintain a predetermined overpressure inside the full face mask the blower unit comprises a differential pressure gauge. In the embodiment illustrated in the Figs. 1 and 4, a differential pressure sensor 39 with a flexible diaphragm 40 is used together with a combination 41 of an IR light emitter and a reflected IR light receiver for IR light reflected from the surface of diaphragm. The sensor comprises said flexible diaphragm 40 arranged at a distance above the printed circuit card 30 defined by a spacer 42 and a cover 43 being fastened to the printed circuit card and having a channel 44 communicating with the ambient through the filter unit via a separate opening 8, Fig. 1, in the upper wall of the blower unit compartment 5. The diaphragm 40 has a diameter exceeding the diameter defined by the spacer or a seat for the diaphragm in the spacer or in the cover, and with a free space underneath and above the diaphragm.

When the pressure outside the filter unit exceeds the pressure in the full face mask the diaphragm will "flap" downwards, and when the pressure in the full face mask exceeds the pressure outside the filter unit the diaphragm will "flap" upwards. The sensor sensing the reflected IR light will react and signals will be sent to a microprocessor on the printed circuit card, which with appropriate circuitry will regulate the blower motor accordingly to maintain a desired overpressure in the full face mask.

The motor 34 is a small motor with sensors controlled by a microprocessor. The microprocessor also receives signals regarding for example pressure and battery charge level. Based on data signals received, the microprocessor sends out audible and/or visual warning signals and instructions for the operation of the motor.

In Fig. 5, a further embodiment of the full face mask sealing is illustrated. The sealing 50 has an integral part 51 forming an inner mask sealing off an upper volume in the full face mask from a lower volume. A front edge 52 of the part 51
5 sealingly abuts the inner surface of the full face mask above the air outlet of the full face mask. As illustrated in Fig. 5 the upper and lower volumes communicate through openings 53, 54. One-way valves may be arranged in said openings. In an alternative embodiment a front edge 52 is made flexible in
10 order to seal against the inner surface of the full face mask during exhalation, and open during inhalation.

The purpose of the inner mask is to reduce the exhalation air volume and prevent build up of CO₂ inside the full face mask in case the blower unit stops working. At the same time this
15 allows the use of the full face mask in APR mode, i.e. as an Air Purifying Respirator.

In order to make the full face mask for a PAPR according to the invention more flexible, it is possible to provide the an inner mask, and in case the inner mask is not wanted, it can
20 be removed. In order to simplify this option, weakening lines can be arranged as is illustrated in Fig. 5 with a dotted line 55 in the areas, where the inner mask is connected to the full face mask sealing 50.

A second embodiment of the full face mask according to the invention is schematically illustrated. Only the differences
25 between this embodiment and the embodiment according to Figs. 1 - 5 will be discussed.

The full face mask 60 differs from the full face mask according to the previous embodiment in that it is designed
30 with an integrated sealing rim 61. This rim 61 also forms a seating for a harness 62 comprising a closed band element 63

adapted to fit snugly around the perimeter of the full face mask and to abut the rim 61 thereof. Straps 64 fastened in the band element 63 have the function to tighten the full face mask against the face of a wearer.

5 A suitable embodiment to the sealing rim 61 of the full face mask is illustrated in Fig. 6a. The rim is formed with folds 65 and a free end part 66 approximately perpendicular to the extension of the adjacent part of the full face mask. With this embodiment the sealing rim will act as a bellows which
10 adjusts to the face of a wearer, indicated at 67.

The rim can of course be designed in different forms giving the same effect, but as shown, it should be resilient, and of course, it should be possible to produce the full face mask in a one step vacuum forming process inclusive of the rim.

15 In Fig. 7 the full face mask 60 is shown inserted in the harness 62.

One great advantage with the embodiment according to Fig. 6 and 7 is that the full face mask is produced in one piece, and no extra sealing means is needed. The harness can be reused
20 when the face mask needs to be discarded.

Claims

1. A full face mask for a PAPR (Powered Air Purifying Respirator) to be used in health hazardous environments, having an air inlet (7, 8) and an air outlet (16),
5 **characterized in** that it is manufactured in one piece from a transparent plastic in a one step vacuum forming process with a single curved field of vision (4) exempt from distortions.
2. A full face mask according to claim 1, further comprising a compartment (5) inside the full face mask for accommodating a
10 blower unit (2).
3. The full face mask according to claim 2, further comprising a filter unit (10 - 12) as an integral part of the full face mask (1).
4. The full face mask according to claim 3, wherein said full
15 face mask (1; 60) with filter unit (10 - 12) is a disposable.
5. The full face mask according to any of the preceding claims, wherein the filter unit (10 - 12) comprises an electrostatic filter, a HEPA filter, a carbon filter or any combination thereof.
- 20 6. The full face mask according to any of the preceding claims, wherein the full face mask (1; 60)) is manufactured from PET.
7. The full face mask according to any of the preceding claims, further comprising a face sealing (3) manufactured as
25 a separate piece and bonded to the full face mask (1).
8. The full face mask according to claim 7, wherein said face sealing (3) comprises an integral portion (51) serving as an

inner mask sealing against an inside of the full face mask (1) for minimizing an exhalation volume inside the full face mask.

9. The full face mask according to claim 8, wherein said inner mask (51) has air inlet openings (53, 54).

5 10. The full face mask according to claim 9, wherein one-way valves are arranged in said openings (53, 54).

11. The full face mask according to any of claims 8 or 9, wherein said inner mask (51) sealingly engages with an inside of the full face mask (1) at exhalation, but allows air to
10 pass when a pressure above said inner mask exceeds the pressure below said inner mask.

12. The full face mask according any of claims 1 - 6, wherein said full face mask (60) comprises an integrated resilient sealing rim (61) formed in said one step vacuum forming
15 process.

13. A method for the manufacture of a full face mask according to any of claims 1 - 12, **characterized in** that the full face mask is manufactured from a transparent plastic in one piece in a one step vacuum forming process, wherein a plastic film
20 or sheet is heated, while heat is prevented from reaching an area corresponding to a field of vision of the full face mask, and wherein the field of vision is given a single curved form against a forming surface, and upon cooling of the heated parts, these parts maintain the form of the single curved,
25 distortion-free field of vision.

14. A PAPR comprising a full face mask (1; 60) according to any of the preceding claims and manufactured with a method according to claim 13, comprising an air inlet (7, 8), an air outlet (16) and a blower unit (2).

15. The PAPR according to claim 14, wherein a one-way valve (17, 18) is arranged in said air outlet (16) with a housing (19) surrounding said air outlet on the outside of said full face mask enclosing a volume sufficient to prevent surrounding
5 air to enter the face mask before the valve closes at inhalation.

16. The PAPR according to claim 14 or 15, wherein a one-way valve (13, 15) is arranged in the air inlet (7, 8).

17. The PAPR according to any of claims 14 - 16, comprising a
10 full face mask (60) with an integrated sealing rim (61) formed in said one-step vacuum forming process, and a harness (62) adapted to be removably fitted around the full face mask (60) and to abut said rim (61) when the full face mask and the harness are assembled

15 18. The PAPR according to any of the claims 14 - 17, wherein the blower unit (2) comprises a differential pressure sensor (39).

19. The PAPR according to claim 18, wherein said differential pressure sensor (39) comprises an IR light emitter, a
20 reflected IR light receiver, and an IR light reflecting surface reactive to a pressure difference between the outside and the inside of the full face mask.

20. The PAPR according to claim 19, wherein said IR light reflecting surface is the surface of a flexible diaphragm (40)
25 arranged in the blower unit (2) and communicating on one side with ambient pressure and on the other side with the pressure prevailing inside the full face mask (1).

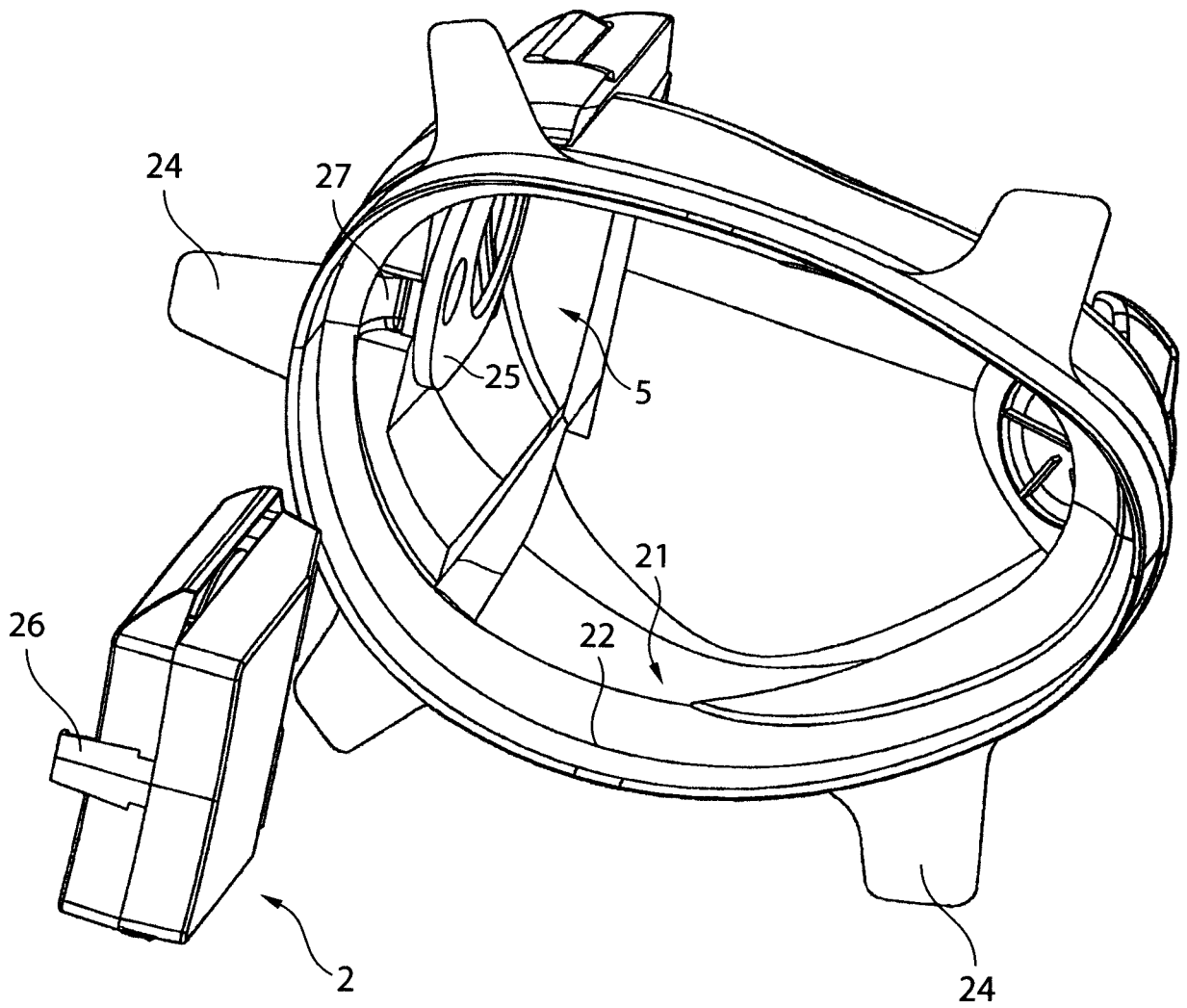

FIG. 2

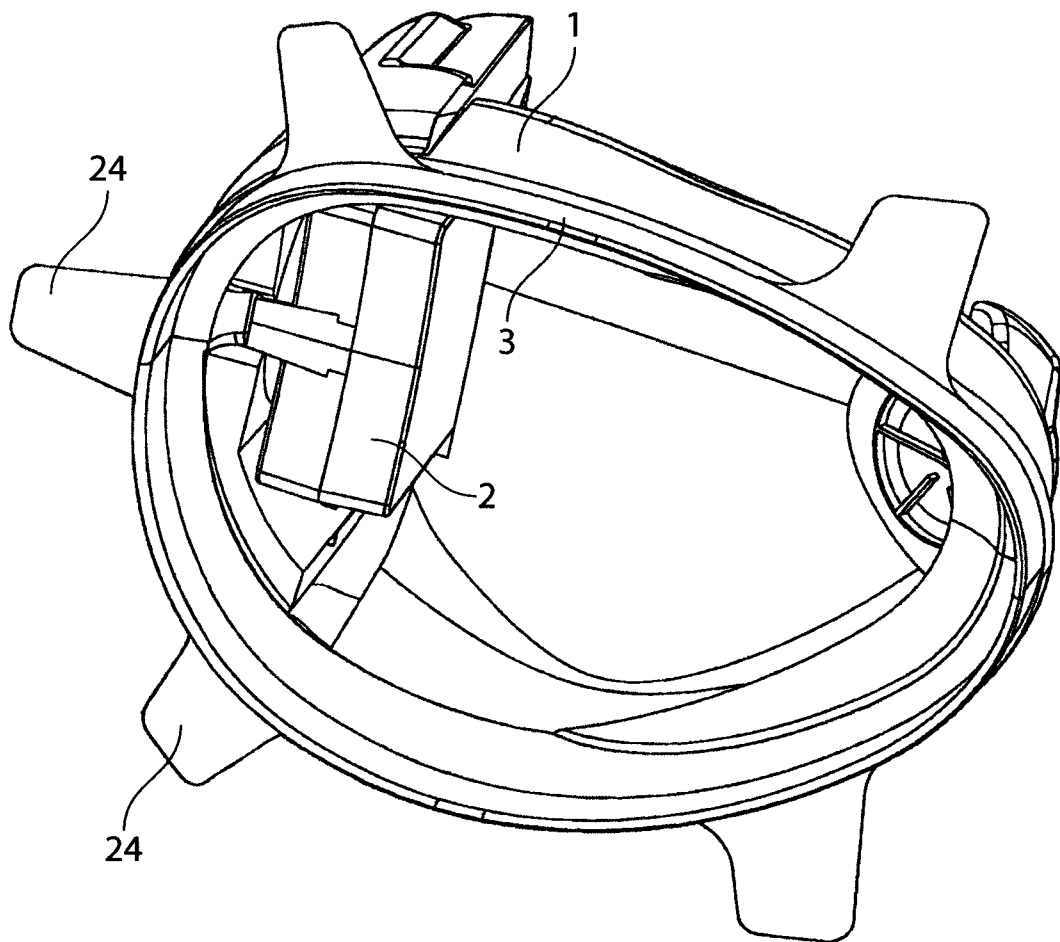

FIG. 3

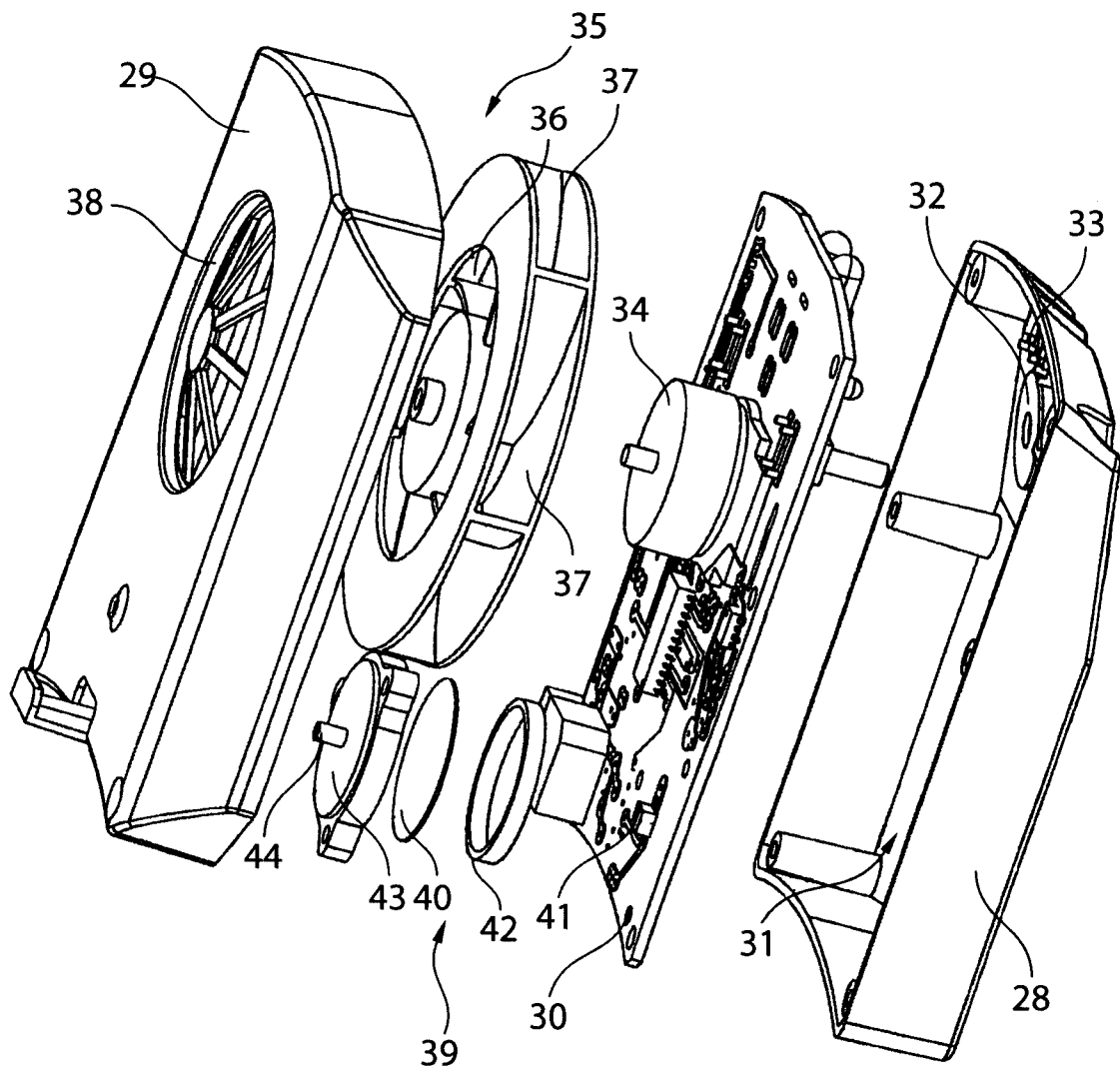

FIG. 4

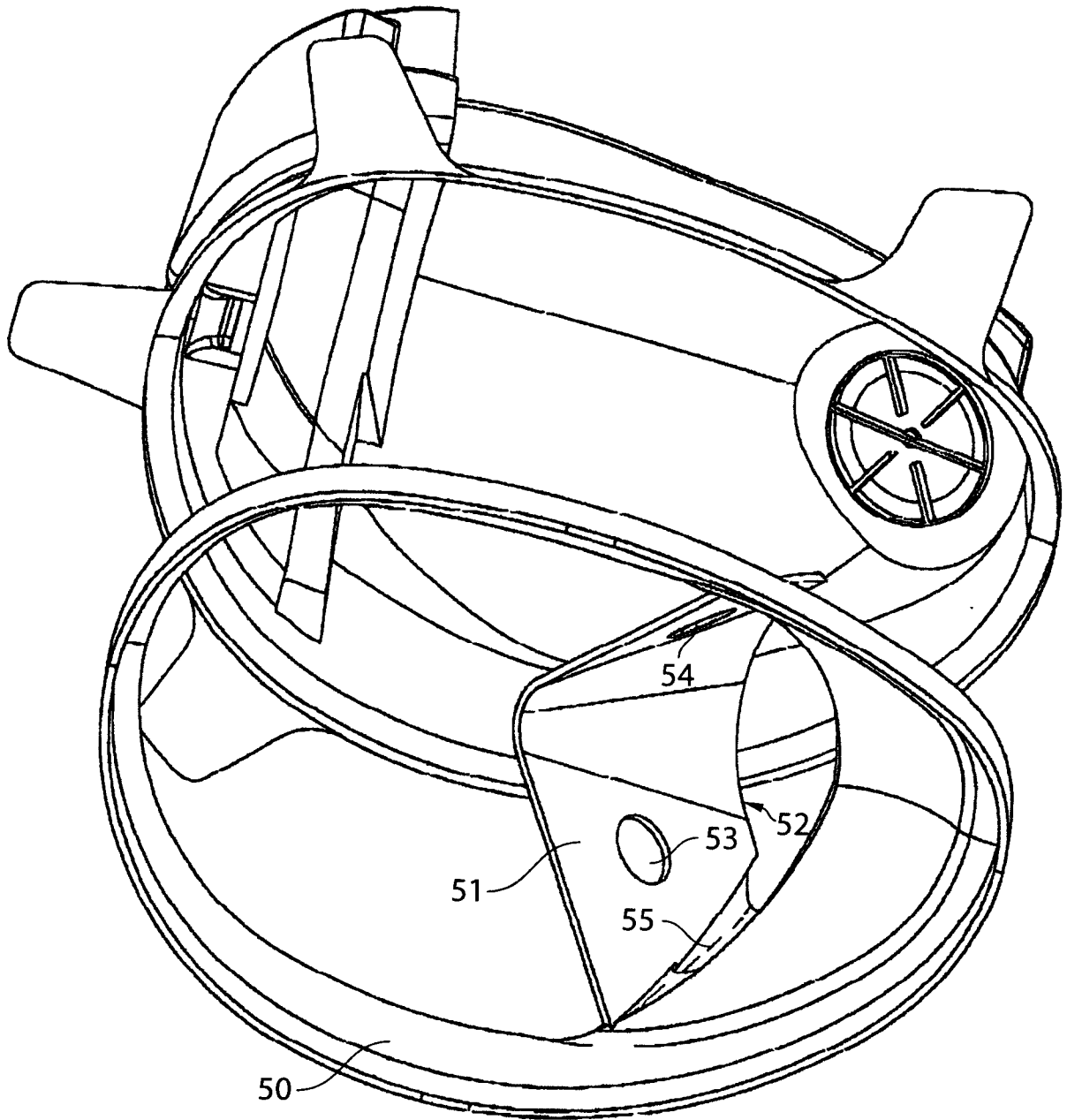

FIG. 5

6 / 6

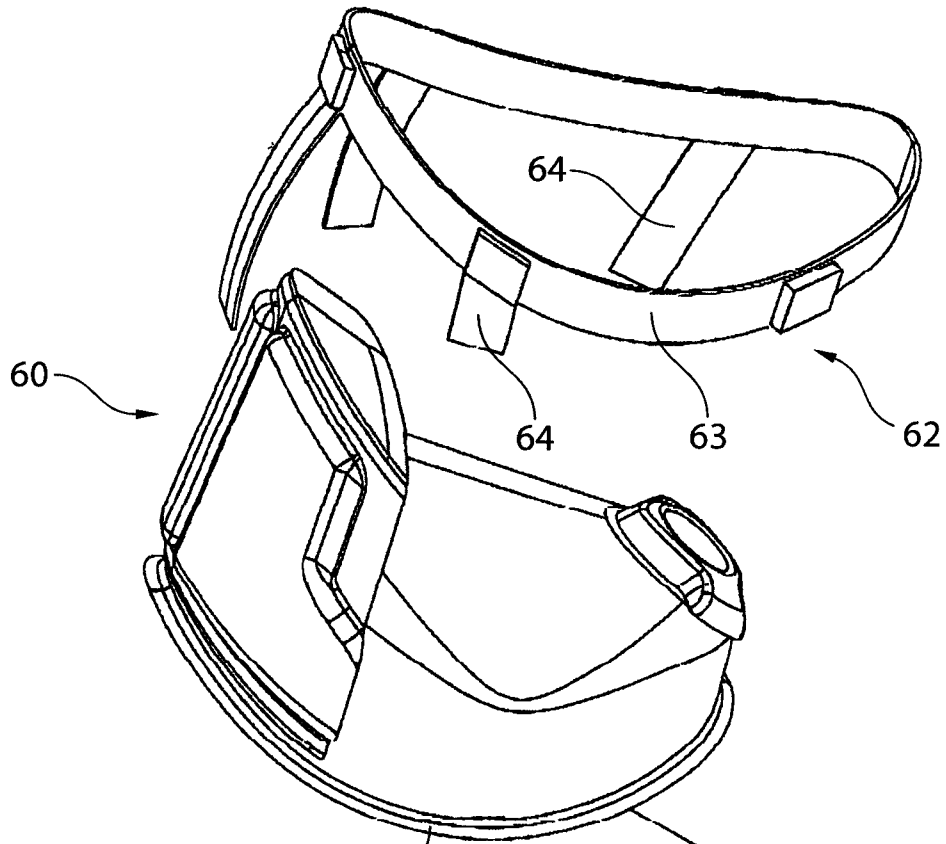

FIG. 6

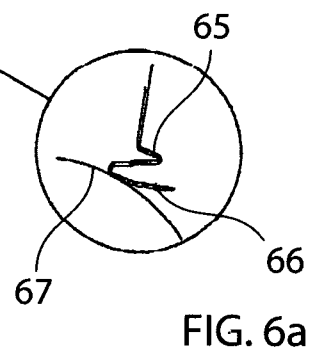
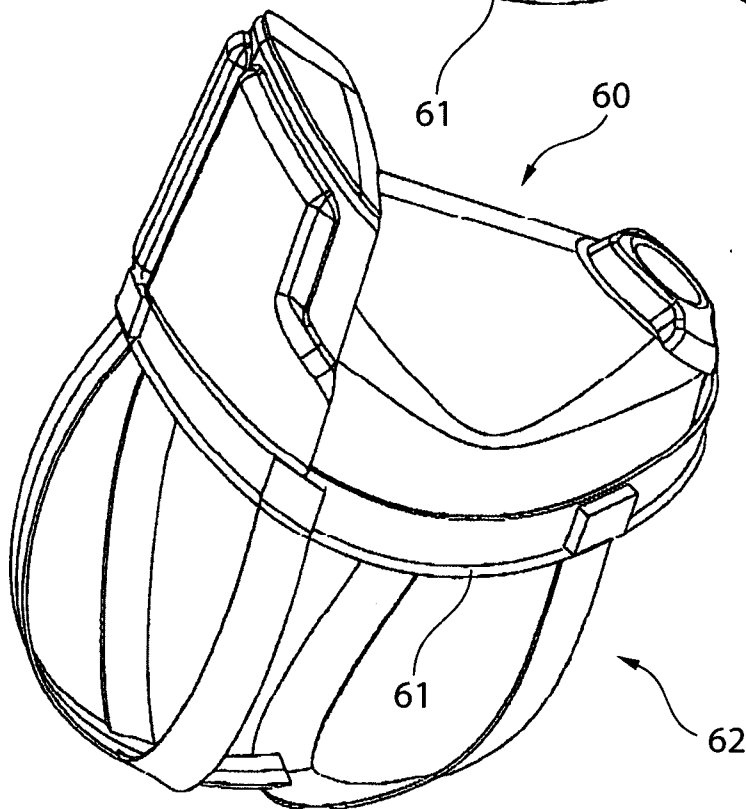

FIG. 6a

FIG. 7

INTERNATIONAL SEARCH REPORT

International application No.
PCT/SE2011/050729

A. CLASSIFICATION OF SUBJECT MATTER		
IPC: see extra sheet		
According to International Patent Classification (IPC) or to both national classification and IPC		
B. FIELDS SEARCHED		
Minimum documentation searched (classification system followed by classification symbols)		
IPC: A62B, B29C, B29D		
Documentation searched other than minimum documentation to the extent that such documents are included in the fields searched		
SE, DK, FI, NO classes as above		
Electronic data base consulted during the international search (name of data base and, where practicable, search terms used)		
EPO-Internal, PAJ, WPI data		
C. DOCUMENTS CONSIDERED TO BE RELEVANT		
Category*	Citation of document, with indication, where appropriate, of the relevant passages	Relevant to claim No.
Y	US 20070235032 A1 (BETZ JAMES R ET AL), 11 October 2007 (2007-10-11); abstract; figures 1,3; [0027]-[0033] --	1-20
Y	WO 2009023599 A1 (MEDONYX INC ET AL), 19 February 2009 (2009-02-19); abstract; figure 1; [0005]-[0006], [0009]-[0011], [0016]-[0019] --	1-20
A	DE 1000239 B1 (DRAEGERWERK AG), 3 January 1957 (1957-01-03); column 1, line 46 - column 2, line 49 --	1-20
A	US 7007690 B1 (GROVE COREY M ET AL), 7 March 2006 (2006-03-07); abstract; figure 2 --	1-20
<input checked="" type="checkbox"/> Further documents are listed in the continuation of Box C. <input checked="" type="checkbox"/> See patent family annex.		
* Special categories of cited documents: "A" document defining the general state of the art which is not considered to be of particular relevance "E" earlier application or patent but published on or after the international filing date "L" document which may throw doubts on priority claim(s) or which is cited to establish the publication date of another citation or other special reason (as specified) "O" document referring to an oral disclosure, use, exhibition or other means "P" document published prior to the international filing date but later than the priority date claimed "T" later document published after the international filing date or priority date and not in conflict with the application but cited to understand the principle or theory underlying the invention "X" document of particular relevance; the claimed invention cannot be considered novel or cannot be considered to involve an inventive step when the document is taken alone "Y" document of particular relevance; the claimed invention cannot be considered to involve an inventive step when the document is combined with one or more other such documents, such combination being obvious to a person skilled in the art "&" document member of the same patent family		
Date of the actual completion of the international search		Date of mailing of the international search report
27-09-2011		29-09-2011
Name and mailing address of the ISA/SE Patent- och registreringsverket Box 5055 S-102 42 STOCKHOLM Facsimile No. + 46 8 666 02 86		Authorized officer Monika Bohlin Telephone No. + 46 8 782 25 00

INTERNATIONAL SEARCH REPORT

International application No.
PCT/SE2011/050729

C (Continuation). DOCUMENTS CONSIDERED TO BE RELEVANT		
Category*	Citation of document, with indication, where appropriate, of the relevant passages	Relevant to claim No.
A	EP 2165739 A1 (MOLDEX METRIC INC), 24 March 2010 (2010-03-24); abstract; figure 1 --	1-20
A	EP 0304641 A1 (MORGAN TECH LTD), 1 March 1989 (1989- 03-01); abstract; figure 3 --	1-20
A	WO 9813103 A1 (MINNESOTA MINING & MFG), 2 April 1998 (1998-04-02); abstract; figure 1 --	1-20
A	US 6996846 B1 (KARAPETYAN ARMEN), 14 February 2006 (2006-02-14); abstract; figure 1 --	1-20
A	US 5023023 A (ELENEWSKI ALLEN), 11 June 1991 (1991- 06-11); abstract; figure 1 --	1-20
A	GB 2215267 A (AMERICAN OPTICAL CORP), 20 September 1989 (1989-09-20); abstract; figures 2, 7 -- -----	1-20

Continuation of: second sheet

International Patent Classification (IPC)

A62B 18/08 (2006.01)

A62B 18/02 (2006.01)

B29C 51/10 (2006.01)

B29D 11/00 (2006.01)

Download your patent documents at www.prv.se

The cited patent documents can be downloaded:

- From "Cited documents" found under our online services at www.prv.se
(English version)
- From "Anförda dokument" found under "e-tjänster" at www.prv.se
(Swedish version)

Use the application number as username. The password is **UZXBUPZXZJ**.

Paper copies can be ordered at a cost of 50 SEK per copy from PRV InterPat (telephone number 08-782 28 85).

Cited literature, if any, will be enclosed in paper form.

INTERNATIONAL SEARCH REPORT

Information on patent family members

International application No.

PCT/SE2011/050729

US	20070235032 A1	11/10/2007	BR	PI0709445 A2	12/07/2011
			CN	101415466 A	22/04/2009
			EP	2001562 A4	02/12/2009
			JP	2009532109 A	10/09/2009
			KR	20080113383 A	30/12/2008
			RU	2401141 C2	10/10/2010
			RU	2008138403 A	10/05/2010
			US	7594510 B2	29/09/2009
			US	20090272378 A1	05/11/2009
			WO	2007117871 A1	18/10/2007
WO	2009023599 A1	19/02/2009	AU	2008287011 A1	19/02/2009
			CA	2696079 A1	19/02/2009
			EP	2188109 A1	26/05/2010
DE	1000239 B1	03/01/1957	NONE		
US	7007690 B1	07/03/2006	NONE		
EP	2165739 A1	24/03/2010	NONE		
EP	0304641 A1	01/03/1989	CH	672741 A5	29/12/1989
			US	5080092 A	14/01/1992
WO	9813103 A1	02/04/1998	BR	9711298 A	17/08/1999
			CA	2264874 C	07/12/2004
			DE	69737482 T2	13/12/2007
			EP	0957993 B1	14/03/2007
			JP	2001505080 A	17/04/2001
			JP	4110238 B2	02/07/2008
			US	5924420 A	20/07/1999
US	6996846 B1	14/02/2006	NONE		
US	5023023 A	11/06/1991	NONE		
GB	2215267 A	20/09/1989	CA	1328541 C	19/04/1994
			US	4950445 A	21/08/1990