

- [54] **BREATHING THERAPY AID**
- [75] Inventors: **Dennis M. DePass**, West Islip; **Bruce Berger**, Mastic, both of N.Y.
- [73] Assignee: **Dennis DePass**, Islip Terrace, N.Y.
- [22] Filed: **Sept. 24, 1973**
- [21] Appl. No.: **399,999**

2,605,763 8/1952 Smoot..... 128/173 H
 3,794,072 2/1974 Diedrich..... 128/209

FOREIGN PATENTS OR APPLICATIONS

226,793 4/1943 Switzerland..... 128/210

Primary Examiner—Richard A. Gaudet
Assistant Examiner—Henry J. Recla
Attorney, Agent, or Firm—Ryder, McAulay, Fields, Fisher & Goldstein

- [52] U.S. Cl. **137/604**; 128/210
- [51] Int. Cl.² **F16K 15/00**
- [58] **Field of Search** 128/210, 209, 196, 197, 128/194, 205, 145 R, 145.8, 145.5, 277, 185; 137/604; 239/427.3, 428.5, 419.5

[57] **ABSTRACT**

A regulator is positioned between a source of oxygen under pressure and a face mask. Variable side wall openings in the regulator control the dilution of the oxygen passed through the regulator by entraining ambient air. A rotatable sleeve effects the opening and closing of the side wall openings.

- [56] **References Cited**
- UNITED STATES PATENTS**
- 417,795 12/1889 Starr 128/209
- 821,354 5/1906 Gebauer 128/210
- 1,527,927 2/1925 Schroder..... 128/209

6 Claims, 5 Drawing Figures

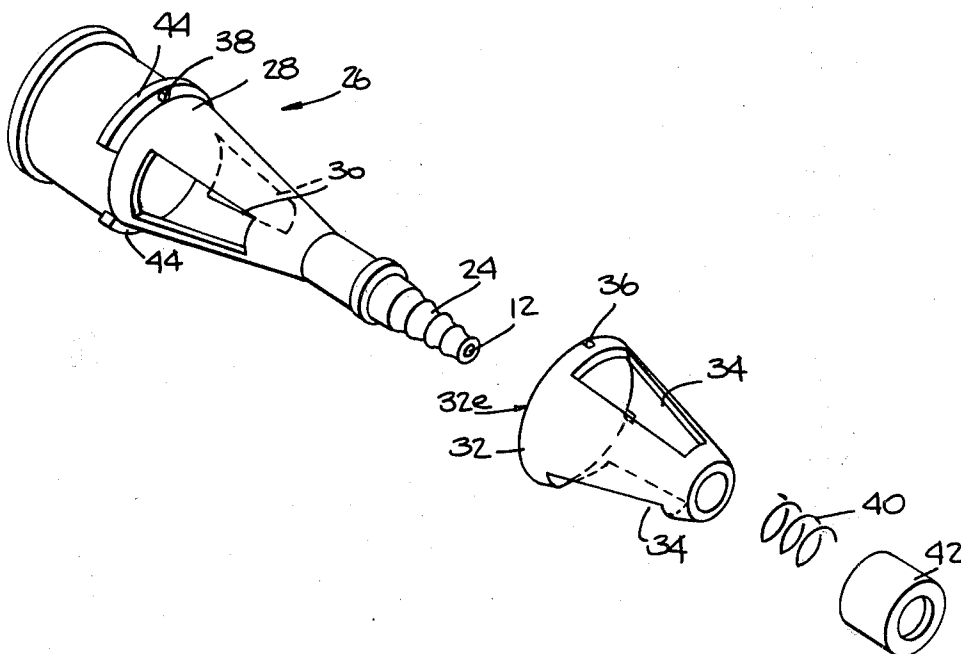

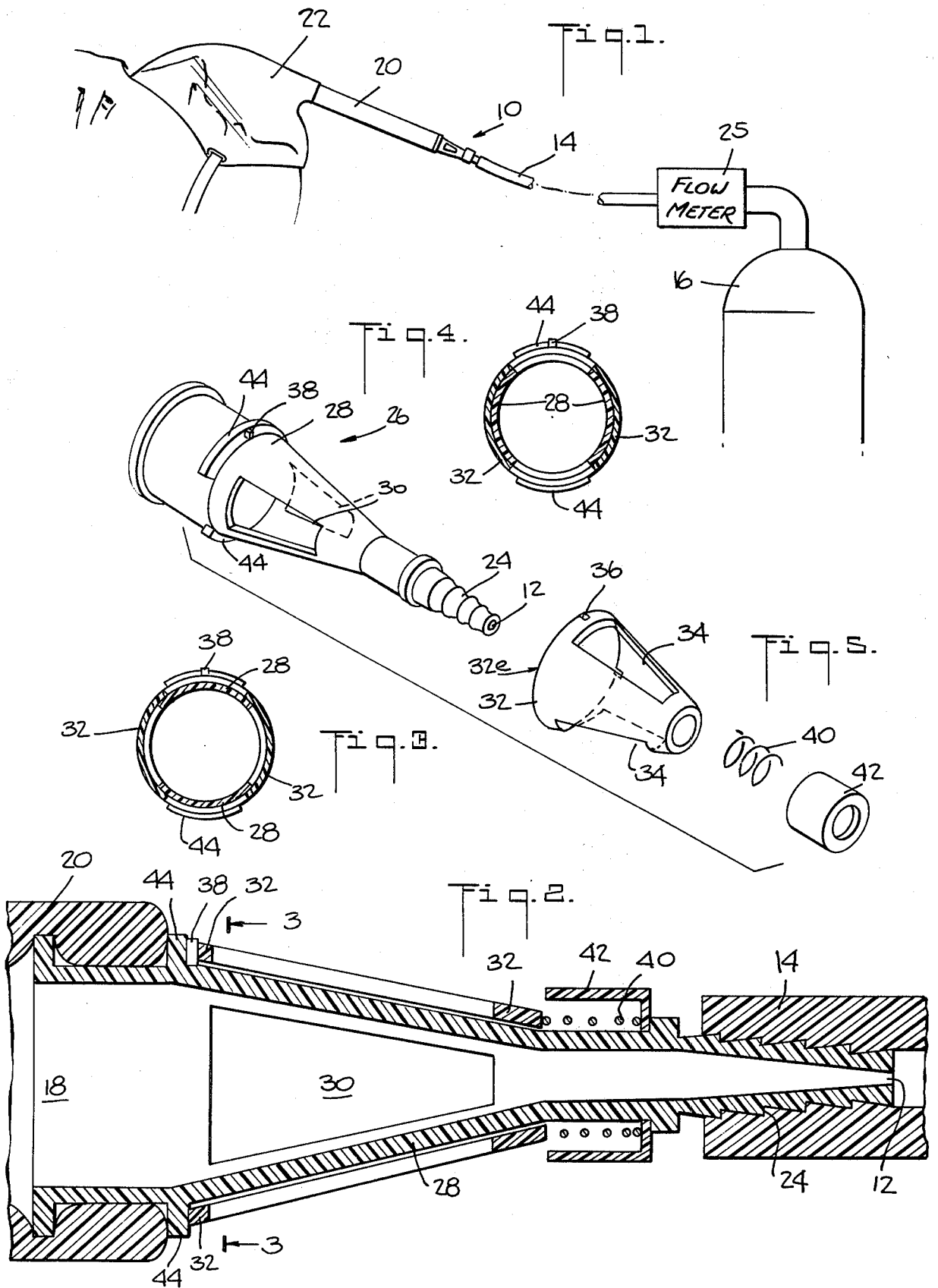

BREATHING THERAPY AID

This invention relates in general to breathing therapy and more particularly to a simple device to regulate the percentage of oxygen in the mixture provided to a patient requiring an oxygen-enriched mixture for breathing.

BACKGROUND OF THE INVENTION

It is well known to provide patients with an oxygen-enriched "air" breathing supply to provide respiratory assistance.

The therapy requires that the percentage of oxygen be controlled and regulated to a pre-determined known amount. The therapy involved also frequently requires that the pre-determined percentage be adjustable by the administrative therapist, particularly where the patient's condition changes in a fashion that indicates a requirement for a change in the percentage of oxygen breathed in by the patient.

There are known devices to achieve these functions. But an improved device is needed so that the therapist can readily and simply change the percentage of oxygen provided whenever required, without any time delay and with a minimum complexity of operation.

It is an important purpose of this invention to provide a breathing aid device which will combine the objectives of permitting a change to a known fixed percentage of oxygen by a simple manipulation of a device that is simple in construction, inexpensive to manufacture and that will avoid interrupting the therapy during the process of changing the concentration of oxygen.

It is another purpose of this invention to provide such a device that will be relatively safe in that it requires a deliberate action in order to change the oxygen concentration.

It is a further purpose that the above purposes be achieved in a device that is reliable in providing the selected percentage of oxygen constantly and continuously without variation in oxygen concentration until the therapist purposefully decides to change the concentration.

It is a further purpose that the device of this invention operate in a quiet and unobtrusive manner.

BRIEF DESCRIPTION OF THE INVENTION

In brief, this invention is in a regulating mechanism having an input port adapted to be connected to tubing from a tank of oxygen having a flow meter. The flow meter controls the volume rate of flow of oxygen to the input port of the regulator. The oxygen passes through the main body of the regulator out an exit port. The exit port has a substantially greater diameter than the oxygen input port and the regulator has a conical zone which provides an increased diameter as the oxygen flows downstream. This conical zone has substantial side wall ports and is surrounded by a rotatable sleeve. The rotatable sleeve also has substantial side wall ports. In one position of the rotatable sleeve, the sleeve wall completely covers the side wall ports in the conical zone so that only a minimal amount of air will be drawn into the regulator. In a second position, 90° from the first position, the side wall ports of the sleeve and conical zone overlap so that there is maximum communication with the ambient air and maximum dilution of the oxygen being fed to the patient. Intermediate positions

of the sleeve provide for intermediate levels of oxygen concentration.

The sleeve is biased by a compressible spring in a downstream direction and various notches in one end of the sleeve mate with an indexing tab so that the sleeve can be held at any one of a plurality of pre-determined fixed positions. With the flow meter set for a pre-determined flow rate of oxygen, the sleeve at a pre-determined one of its positions will then provide a pre-determined oxygen dilution so that the therapist will have a known oxygen concentration supplied to the patient.

BRIEF DESCRIPTION OF THE DRAWINGS

FIG. 1 illustrates the breathing aide system employing this invention.

FIG. 2 is a longitudinal cross-sectional view of the regulator used in the FIG. 1 system.

FIG. 3 is a cross-sectional view along the line 3—3 of FIG. 2 showing the side wall ports fully covered.

FIG. 4 is a cross-sectional view similar to that of FIG. 3 showing the side wall ports fully opened.

FIG. 5 is a blown-up perspective of the FIG. 2 regulator.

DESCRIPTION OF THE PREFERRED EMBODIMENTS

With reference to the drawings, all of which relate to the same embodiment, the regulator 10 has an inlet port 12 connected to a tube 14 from a source 16 of oxygen under pressure. An outlet port 18 is in communication with a conduit or chamber 20 that is directly associated with the face mask 22 designed to provide oxygen enriched "air" to a patient. The serrations 24 on the upstream end of the regulator 10 serve to engage the inner surface of the rubber like tube 14.

A flow meter 25 regulates the quantity of oxygen flowing through the system. The regulator 10 then regulates the quantity of air added to that determined quantity of oxygen and thus regulates the concentration of oxygen in the mixture which the patient breathes.

The main body 26 of the regulator 10 has a frusto conical center portion 28 having two large and substantial side wall ports 30. Mounted on this frusto-conical section 28 is a frusto-conical sleeve 32 that also has two side wall ports 34 which are designed to match the ports 30. These side wall ports 30 and 34 are designed to subtend an angle from the axis of the regulator 10 that is substantially less than 90°. Thus, in one position of the rotatable sleeve 32 (see FIG. 4) the ports 34 will overlie the ports 30 and provide maximum communication with the ambient air. A 90° rotation of the sleeve 32 (see FIG. 3) will substantially shut off the ports 30 from communication with the air. In this fashion, the oxygen mixture can be made to range widely as a function of the position of the sleeve 32.

The downstream edge of the sleeve 32 has a series of notches 36 which mate with a tab 38 on the main body 26 to hold the sleeve 32 in position.

The sleeve 32 is biased in an upstream direction by a spring 40 held within a housing 42 mounted on the body 28 immediately upstream of the frusto-conical portion 28. Thus, manual adjustment of the sleeve 32 in order to vary the percentage of oxygen in the mixture delivered at the outlet port 18 is made by pushing the sleeve 32 against the spring 40 so as to disengage

the notches 36 and tab 38 and then rotating the sleeve 32 to a new position. The positions to which the sleeve 32 can be turned for use are not continuous and the number of such positions to determine by the number of notches 36.

With the exception of the ports 30 and 34, most of the cross sections through the regulator 10 will show radial symmetry. However, the flanges 44 do not extend around 360°. The purpose of the substantial cut-out area between the two flanges 44 is to provide an adequate finger hold of the downstream end 32e of the sleeve 32 so that the sleeve 32 can be pushed against the spring 40 for resetting of the oxygen percentage.

In one embodiment the ports 30, 34 are approximately 1/2 inch long. In that embodiment the ports have a circumferential width such that they subtended an angle with the axis of the device that is approximately 90° but no more than 90° so that when in the closed state, as shown in FIG. 3, the only ambient air that enters into the flow is that which seeps around the small overlap between the body portion of the sleeve 32 and the main body 26. In that embodiment, the diameter of the sleeve 32 extends from about 1/2 inch at the narrowest end of the ports 34 to about 3/4 of an inch at the widest end of the ports 34. The inlet port 12, in that embodiment, is about 1/64th of an inch while the outlet port 18 is about 17/32nds of an inch.

When a regulator having such dimensions was connected to a source of oxygen 16 with the flow meter 25 set to provide 8 liters per minute, the mixture provided to the patient ranged from one having 82 percent oxygen (with the ports closed) to one providing 30 percent oxygen with the ports as open as possible. With the same embodiment, but with the flow meter set to provide four liters per minute flow of oxygen, the air provided to the patient ranged from 40 percent oxygen, supplied with the ports closed, to 32 percent oxygen, with the ports open.

What is claimed is:

1. In a breathing aid system having a source of oxygen under pressure, a flow meter to control the flow rate of oxygen from said source and a face mask for a patient, the improvement in a device for regulating the concentration of oxygen provided to the face mask comprising:

- a first end portion having an inlet port and adapted to be connected to the controlled flow of oxygen,
- a second end portion having an outlet port and

adapted to be placed in communication with the face mask,

an annular center portion between said inlet and said outlet portions, said center portion having a side wall with first and second ports,

a sleeve mounted for circumferential rotation on said center portion, said sleeve having first and second side wall openings, the overlap between said ports on said center portion and said openings on said sleeve varying as a function of the circumferential position of said sleeve on said center portion,

a flange extending outwardly from one end of said center portion,

a spring at the other end of said center portion positioned between said sleeve and one of said end portions and urging said sleeve against said flange,

one of said flange and said sleeve having a tab extending toward and in contact with the adjacent end of the other of said sleeve and said flange,

the other of said sleeve and said flange having a series of notches adapted to mate with said tab to hold said sleeve in a circumferential position determined by the particular one of said notches which is set at said tab.

2. The device of claim 1 wherein:

said inlet port opens into the interior of said center portion upstream from said first and second port of said side wall.

3. The device of claim 1 wherein:

said center portion and said sleeve are frusto-conical having their narrow end adjacent said inlet portion and their wide end adjacent said outlet portion.

4. The device of claim 1 wherein:

said flange extends only partly around the circumference of said center portion leaving an open area at the edge of said sleeve having said notches for finger access.

5. The device of claim 3 wherein:

said inlet port opens into the interior of said center portion upstream from said first and second port of said side wall.

6. The device of claim 3 wherein:

said flange extends only partly around the circumference of said center portion leaving an open area at the edge of said sleeve having said notches for finger access.

* * * * *

50

55

60

65