

(19) World Intellectual Property
Organization
International Bureau



(43) International Publication Date
13 October 2005 (13.10.2005)

PCT

(10) International Publication Number
WO 2005/095188 A1

(51) International Patent Classification⁷: **B62D 25/18**

(21) International Application Number:
PCT/GB2005/001292

(22) International Filing Date: 4 April 2005 (04.04.2005)

(25) Filing Language: English

(26) Publication Language: English

(30) Priority Data:
0407653.5 3 April 2004 (03.04.2004) GB

(71) Applicant and

(72) Inventor: **DOWNES, John, Anthony** [GB/GB]; 28 Mere Avenue, Raby Mere, Wirral CH63 0NE (GB).

(74) Agent: **MORAN, Paula**; Olswang, 90 High Holborn, London WC1V 6XX (GB).

(81) Designated States (unless otherwise indicated, for every kind of national protection available): AE, AG, AL, AM,

AT, AU, AZ, BA, BB, BG, BR, BW, BY, BZ, CA, CH, CN, CO, CR, CU, CZ, DE, DK, DM, DZ, EC, EE, EG, ES, FI, GB, GD, GE, GH, GM, HR, HU, ID, IL, IN, IS, JP, KE, KG, KM, KP, KR, KZ, LC, LK, LR, LS, LT, LU, LV, MA, MD, MG, MK, MN, MW, MX, MZ, NA, NI, NO, NZ, OM, PG, PH, PL, PT, RO, RU, SC, SD, SE, SG, SK, SL, SM, SY, TJ, TM, TN, TR, TT, TZ, UA, UG, US, UZ, VC, VN, YU, ZA, ZM, ZW.

(84) Designated States (unless otherwise indicated, for every kind of regional protection available): ARIPO (BW, GH, GM, KE, LS, MW, MZ, NA, SD, SL, SZ, TZ, UG, ZM, ZW), Eurasian (AM, AZ, BY, KG, KZ, MD, RU, TJ, TM), European (AT, BE, BG, CH, CY, CZ, DE, DK, EE, ES, FI, FR, GB, GR, HU, IE, IS, IT, LT, LU, MC, NL, PL, PT, RO, SE, SI, SK, TR), OAPI (BF, BJ, CF, CG, CI, CM, GA, GN, GQ, GW, ML, MR, NE, SN, TD, TG).

Published:

— with international search report

For two-letter codes and other abbreviations, refer to the "Guidance Notes on Codes and Abbreviations" appearing at the beginning of each regular issue of the PCT Gazette.

(54) Title: SPRAY PREVENTION DEVICE

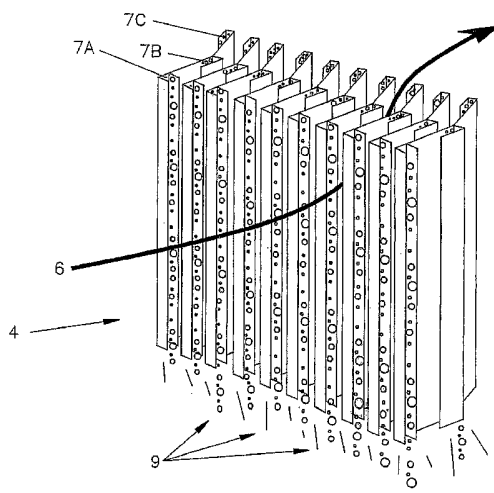

(57) Abstract: A device for preventing spray from emerging from the wheels of vehicles comprises a panel (4) that is adapted to be mounted substantially vertically behind a vehicle wheel (3) for receiving on a first side water released by the wheel (3) as it rotates. The panel (4) includes at least one passage (6) which leads from the first side to a rear second side of the panel (4). The or each passage (6) is other than normal to the plane of the panel (4). There is at least one water-collecting pocket (7A, 7B, 7C) along the side of the or each passage (6). In use, air and water enter the or each passage (6) and are separated so that air passes through the or each passage (6) and mixes with ambient air and water collects in the at least one water-collecting pocket (7A, 7B, 7C).

WO 2005/095188 A1

Spray Prevention Device

The present invention relates to a device to prevent spray from emerging from the wheels of vehicles travelling along roadways in wet weather.

- 5 When vehicles (particularly large vehicles such as lorries) travel along a roadway in wet weather, a spray or mist is generated by the wheels which can seriously impair the vision of drivers of vehicles behind. This is very dangerous and can lead to accidents.

This spray occurs because water on the road is picked up by the rotating tyres and thrown off against the wheel arch. As the water hits the wheel arch, so the water is broken up into small
10 droplets and atomised in the air to create a fine spray or mist. This spray is then ejected sideways out of the wheel arch. In extreme conditions, this spray can be impossible to see through.

It has been known to try and reduce such a spray by lining the rear of a wheel arch with a flap with surface bristles or a mesh which helps to cushion or reduce reflection of the water as it
15 emerges from the wheel. This helps to reduce the break up of water into small particles. This does not however separate the water from the air.

UK Patent Specification 2229689 describes a spray inhibiting wheel guard. This wheel guard is curved to form the rear half of a wheel arch, and consists of a series of longitudinal channels between baffles to guide water out of the wheel arch area and direct it back onto a roadway. It
20 has been found that this arrangement does not work since, when the vehicle is travelling at speed, air is forced into the upper area of the channels creating a back pressure in the channels by travelling down the pockets which prevents the spray from entering the channels.

The present invention seeks to provide a solution to this problem by separating the water from the air in the spray rather than trying to inhibit its formation.

25 According to the present invention there is provided a device to prevent spray from emerging from the wheels of vehicles travelling along roadways in wet weather said device comprising a panel for mounting generally vertically behind the wheel of a vehicle to receive on a first side of the panel water released by the wheel as it rotates, said panel including at least one passage

which leads from the first side to a rear second side of the panel, the or each passage being other than normal to the plane of the panel, and at least one water-collecting pocket along the side of each passage, in use air and water entering the or each passage with air passing through the or each passage and being free to enter ambient air on the second side of the panel but water
5 collecting in the or each passage pocket.

Preferably the panel is formed from a plurality of vertical baffles in a side by side relationship with passages formed therebetween. Preferably the vertical baffles are of identical shape. Preferably the baffles overlap one another. Preferably the panel is substantially planar.

Preferably the or each passage is non-linear. Preferably the or each passage has two changes
10 of direction. Preferably pockets are positioned generally at a tangent to the change of direction in the passages.

The or each-pockets may be a channel running vertically down the baffles whereby water drains down each channel back onto the roadway. The channels may be generally U-shaped. In one embodiment three pockets are formed on each baffle.

15 An embodiment of the invention will now be described with reference to the accompanying drawings in which:

Figure 1 shows a perspective view of the wheel arch of a road vehicle with the device fitted,

Figure 2 shows an enlarged view of Figure 1,

Figure 3 shows a section of Figure 1 showing in schematic form the flow of air and spray there
20 through; and

Figure 4 shows a perspective view of an alternative configuration of the device.

Referring to Figure 1 there is shown a vehicle 1 with a wheel arch 2 over a wheel 3. Mounted below the wheel arch and between the wheel 3 and wheel arch 2 is a generally planar panel 4 made up from a plurality of identical baffles 5 with passages 6 leading from a first side of the
25 panel through to a second side of the panel as shown more clearly in Figure 2. Each baffle includes three water-collecting pockets in the form of vertical U-shaped channels 7A, 7B, 7C on

the side of the passage 6. In use (as described more fully below) on wet road surfaces, water 8 is thrown up by the wheel onto the first side of the panel 4 and passes with air through the passage 6, but a substantial amount of the water is separated from the air by means of inertial forces and collected by channels 7A, 7B, 7C and falls as a stream of water 9 out of the bottom of the panel.

Referring now to Figures 2 and 3, it will be seen that the baffles 5 each overlap so that the passage takes a generally curvaceous path through the pane 4, i.e. the passage is not normal to the plane of the panel and is non-linear through the panel.

Figure 3 shows a path of water and air being thrown at two of the baffles. As viewed, the left hand part of the path throws water and air into the first channel 7A where water will collect. The path then changes direction a first time as shown at "A" as it follows the passage 6. As it changes direction, because water is heavier than air, the water particles tend to follow a straight path and leave the air flow at a tangent thereto into pocket 7B located at a tangent to the change of direction of the passage. The path then changes direction a second time as shown at "B" as it exits passage 6 and much of the water not collected by pocket 7B will leave the air flow at a tangent into pocket 7C located at a tangent to the second change of direction of the passage 6. The air, with much reduced water content, exiting the passage 6 is free to mix with ambient air.

It has been found that good separation of water from air is achievable.

An alternative baffle arrangement is shown in Figure 4. The U-shaped channels 7A', 7B', 7C' have a rounded profile.

As water and air enter the passage 6 they change direction. The water, being the heavier component, tends to enter channel 7A', while the air flows past. Any water that remains in the flow is caught in turn by channels 7B' and 7C' respectively as the stream is forced to change direction again.

It is envisaged that the panel may take a form different to those specifically described above. For example the passage through the panel may change direction only once or more than twice. The pockets may be other than U-shaped channels.

It is envisaged that such a panel may be formed by extruding the baffles, and joining the baffles in side by side relationship, e.g. with elongate horizontal shafts supporting spacers between baffles.

Further modifications will be apparent to those skilled in the art without departing from the scope of the present invention.

CLAIMS:

1. A device for preventing spray from emerging from the wheels of vehicles comprising a panel that is adapted to be mounted substantially vertically behind a vehicle wheel for receiving on a first side water released by the wheel as it rotates, the panel including at least one passage which leads from the first side to a rear second side of the panel, the or each passage being other than normal to the plane of the panel, and at least one water-collecting pocket along the side of the or each passage, wherein, in use, air and water entering the or each passage are separated so that air passes through the or each passage and mixes with ambient air on a second side of the panel, and water collects in the or each water-collecting pocket.
2. A device as claimed in Claim 1, wherein the panel is formed from a plurality of vertical baffles in a side by side relationship with passages therebetween.
3. A device as claimed in Claim 2, wherein the baffles are substantially identical in shape.
4. A device as claimed in Claim 2 or 3, wherein the baffles overlap one another.
5. A device as claimed in any one of the preceding claims, wherein the panel is substantially planar.
6. A device as claimed in any one of the preceding claims, wherein the or each passage is non-linear.
7. A device as claimed in any one of the preceding claims, wherein the water-collecting pockets are arranged so as to collect water following a change of direction in the or each passage.
8. A device as claimed in Claim 7, wherein the or each passage has two changes of direction.
9. A device as claimed in any one of the preceding claims, wherein the or each pocket is a channel running substantially vertically along its respective baffle, so that, in use, water drains from the baffles onto a surface on which the wheel is travelling.

10. A device as claimed in Claim 9, wherein the channel is substantially U-shaped.
11. A device substantially as herein described with reference to any one of the embodiments shown in the accompanying drawings.

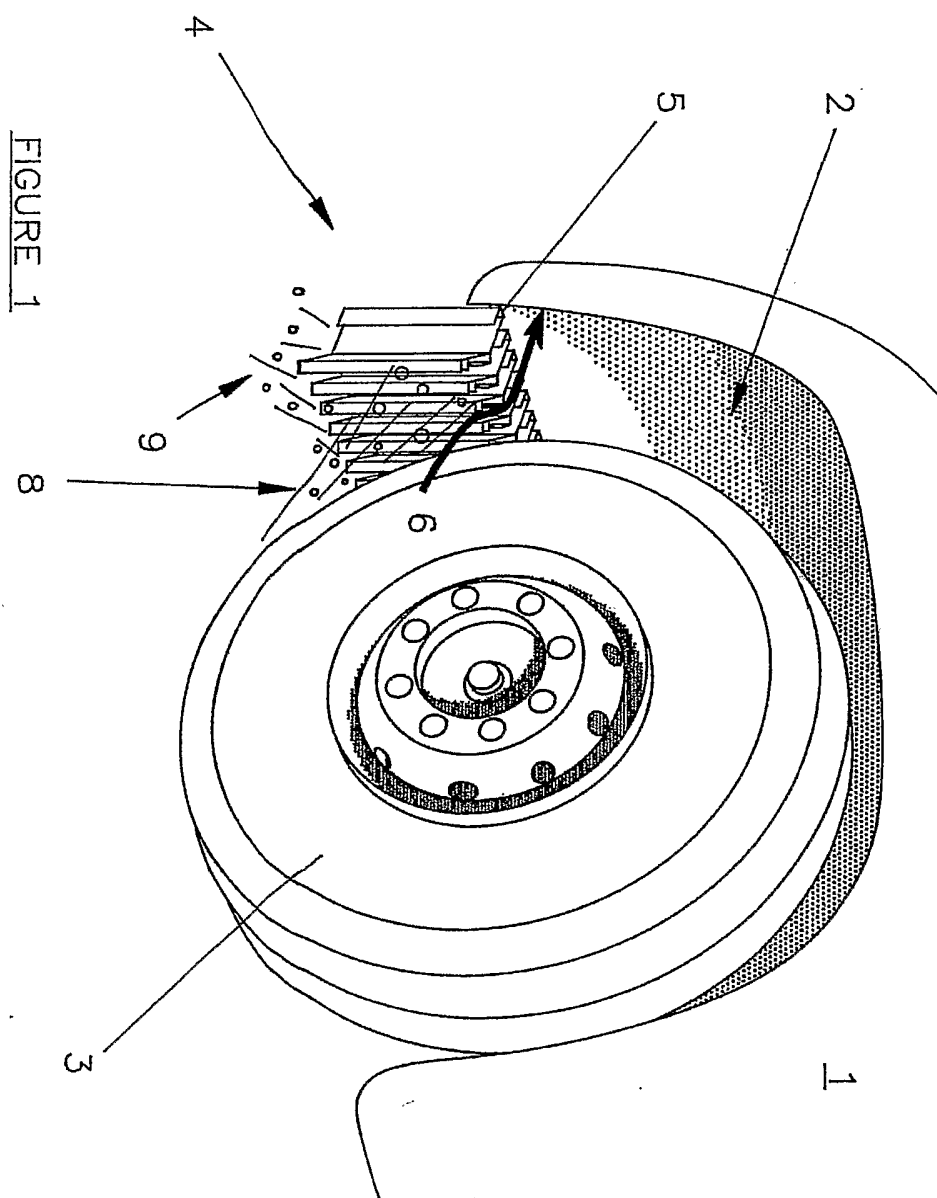

FIGURE 1

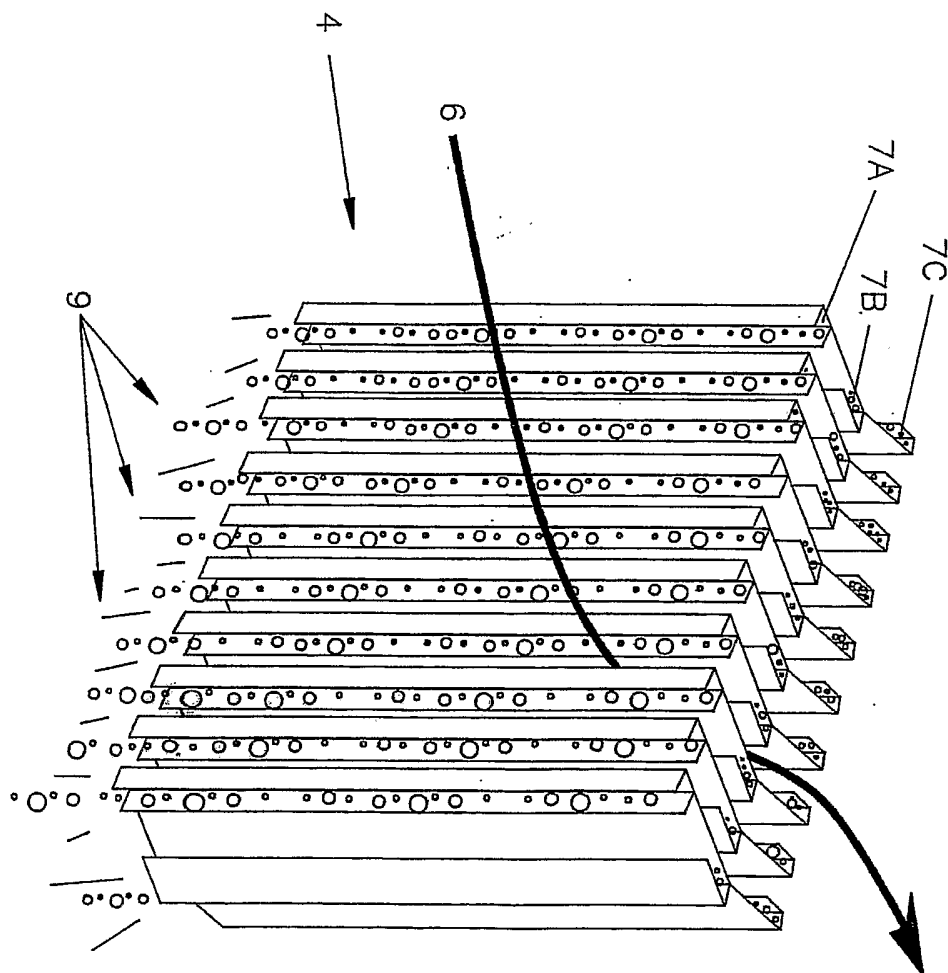

FIGURE 2

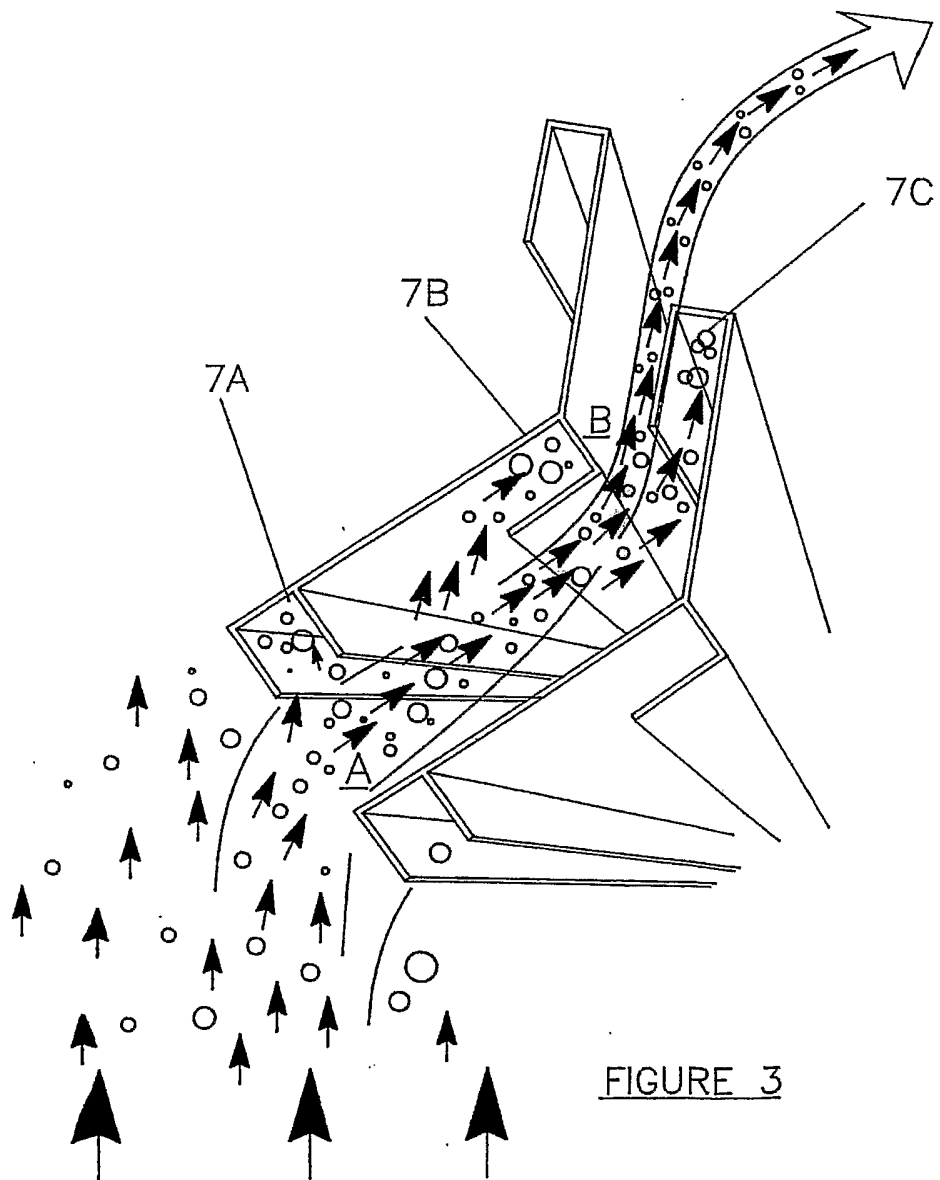
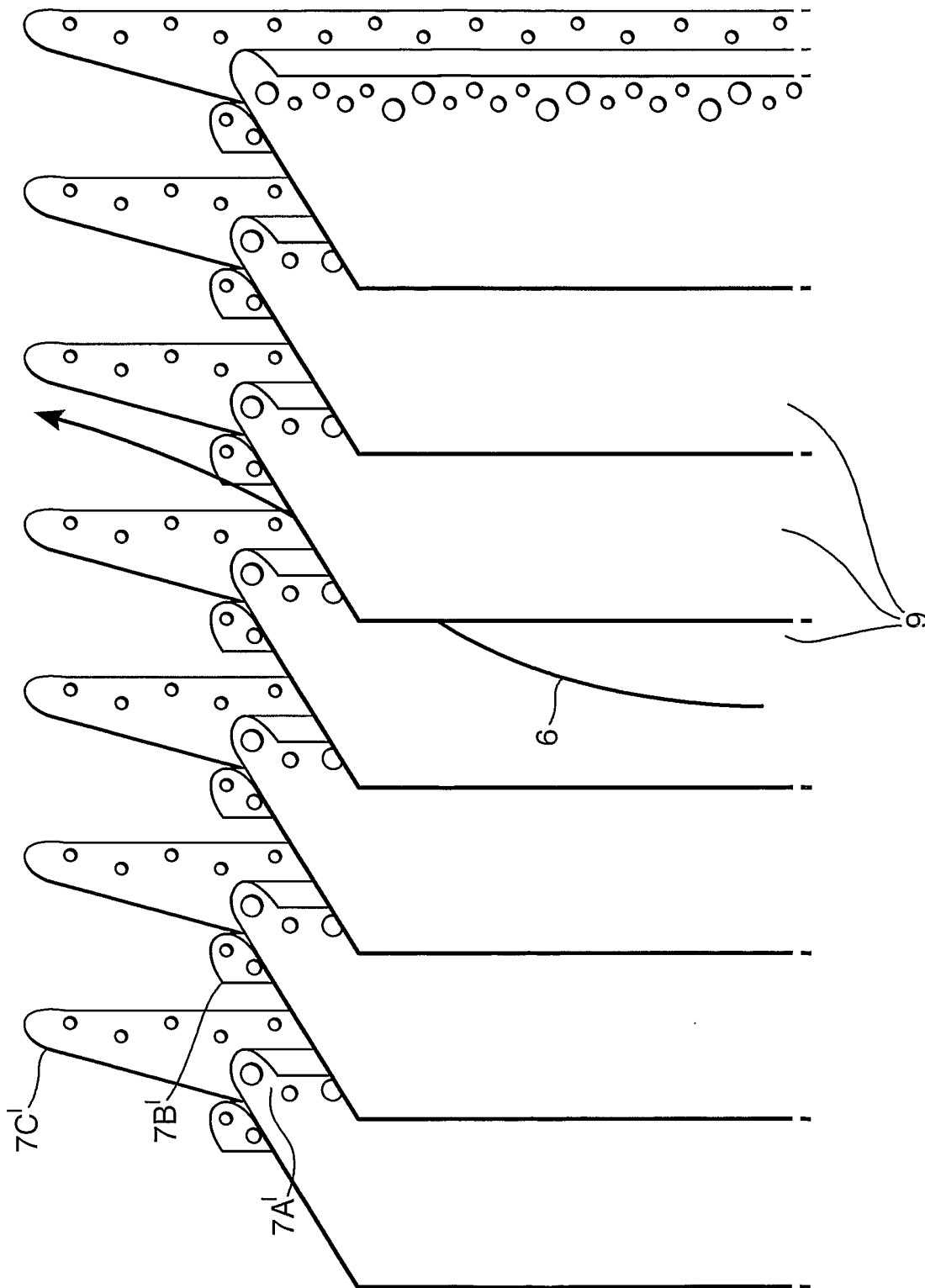

Fig.4.



INTERNATIONAL SEARCH REPORT

PCT/GB2005/001292

A. CLASSIFICATION OF SUBJECT MATTER
IPC 7 B62D25/18

According to International Patent Classification (IPC) or to both national classification and IPC

B. FIELDS SEARCHED

Minimum documentation searched (classification system followed by classification symbols)
IPC 7 B62D

Documentation searched other than minimum documentation to the extent that such documents are included in the fields searched

Electronic data base consulted during the international search (name of data base and, where practical, search terms used)

EPO-Internal, PAJ

C. DOCUMENTS CONSIDERED TO BE RELEVANT

Category °	Citation of document, with indication, where appropriate, of the relevant passages	Relevant to claim No.
X	GB 2 229 689 A (JOHN ANTHONY DOWNES) 3 October 1990 (1990-10-03) cited in the application the whole document	1-11
A	EP 0 825 095 A (DAIMLERCHRYSLER AG; DAIMLER-BENZ AKTIENGESELLSCHAFT) 25 February 1998 (1998-02-25) column 4, line 40 - column 5, line 14 figures 6-8,10	1-11
A	US 5 564 750 A (BAJOREK ET AL) 15 October 1996 (1996-10-15) figure 4 column 3, line 57 - line 62 column 4, line 9 - line 47	1,5,6,11

Further documents are listed in the continuation of box C.

Patent family members are listed in annex.

° Special categories of cited documents :

- "A" document defining the general state of the art which is not considered to be of particular relevance
- "E" earlier document but published on or after the international filing date
- "L" document which may throw doubts on priority claim(s) or which is cited to establish the publication date of another citation or other special reason (as specified)
- "O" document referring to an oral disclosure, use, exhibition or other means
- "P" document published prior to the international filing date but later than the priority date claimed

- "T" later document published after the international filing date or priority date and not in conflict with the application but cited to understand the principle or theory underlying the invention
- "X" document of particular relevance; the claimed invention cannot be considered novel or cannot be considered to involve an inventive step when the document is taken alone
- "Y" document of particular relevance; the claimed invention cannot be considered to involve an inventive step when the document is combined with one or more other such documents, such combination being obvious to a person skilled in the art.
- "&" document member of the same patent family

Date of the actual completion of the international search

17 June 2005

Date of mailing of the international search report

28/06/2005

Name and mailing address of the ISA
European Patent Office, P.B. 5818 Patentlaan 2
NL - 2280 HV Rijswijk
Tel. (+31-70) 340-2040, Tx. 31 651 epo nl,
Fax: (+31-70) 340-3016

Authorized officer

Westland, P

INTERNATIONAL SEARCH REPORT

Information on patent family members

PCT/GB2005/001292

Patent document cited in search report	Publication date	Patent family member(s)	Publication date
GB 2229689	A	03-10-1990	NONE
EP 0825095	A	25-02-1998	DE 19634103 A1 26-02-1998 DE 59705949 D1 14-02-2002 EP 0825095 A2 25-02-1998 ES 2170306 T3 01-08-2002
US 5564750	A	15-10-1996	NONE