

No. 892,456.

PATENTED JULY 7, 1908.

S. B. SCHOLZ.
FASTENING DEVICE FOR GATES AND DOORS.
APPLICATION FILED OCT. 31, 1907.

FIG. 1.

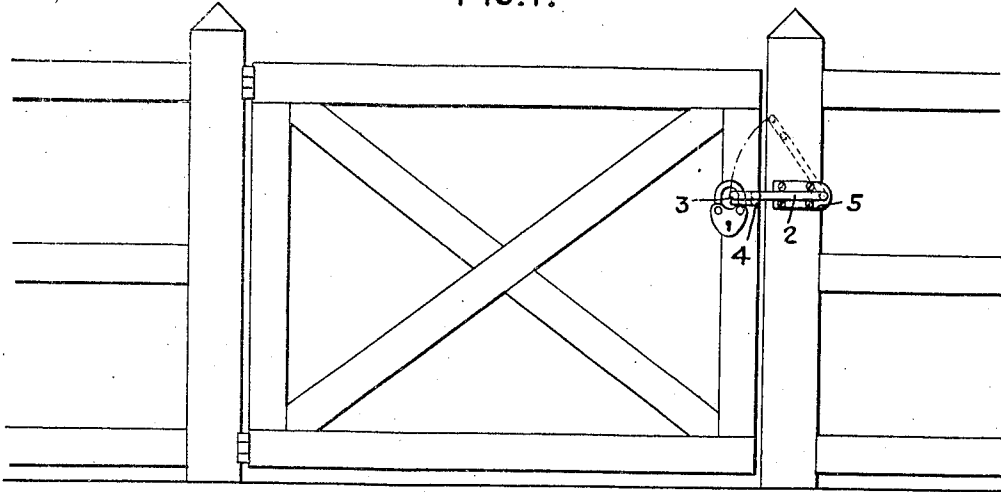

FIG. 2.

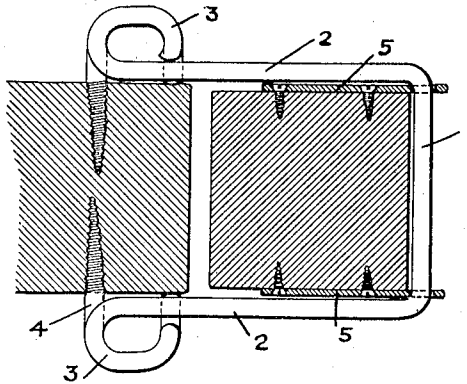

FIG. 4.

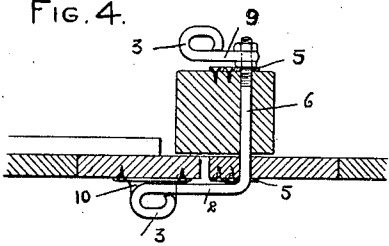
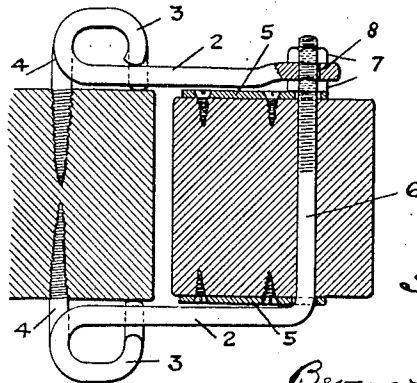

FIG. 3.



S. B. Scholz
Inventor

Berans & Berans

his

Witnesses

Harry F. Pruett
J. M. Copenhaver

By

Attorneys

UNITED STATES PATENT OFFICE.

SAMUEL B. SCHOLZ, OF COLORADO SPRINGS, COLORADO.

FASTENING DEVICE FOR GATES AND DOORS.

No. 892,456.

Specification of Letters Patent.

Patented July 7, 1908.

Application filed October 31, 1907. Serial No. 400,098.

To all whom it may concern:

Be it known that I, SAMUEL B. SCHOLZ, a citizen of the United States, residing at Colorado Springs, in the county of El Paso and State of Colorado, have invented certain new and useful Improvements in Fastening Devices for Gates and Doors, of which the following is a specification.

This invention relates to improvements in fastening devices for gates and doors, and the object is to provide a simple, strong and easily applied device operable from either side of the gate or door for holding the latter from movement in either direction, and at the same time to so arrange the parts that a padlock may be used in connection therewith on either side of the door or gate for locking the latter closed.

With the above objects in view, the invention consists in the novel features of construction hereinafter fully described, particularly pointed out in the claims, and clearly illustrated by the accompanying drawings, in which

Figure 1 is a side elevation of a gate and the adjacent fence posts, showing one form of my invention applied; Fig. 2, a transverse sectional view through the end-bar of the gate and adjacent fence-post showing my improved fastening device in plan view; Fig. 3, a similar view showing a modified construction, and Fig. 4, a sectional view showing the adaptation of the invention to a single swing door or gate.

Referring now more particularly to the drawing, Figs. 1 and 2, the numeral 1 designates the swinging-member of the fastening device which is substantially U-shaped in plan view, thus providing retaining arms 2 to extend on the respective sides of the gate or door when said swinging member is moved to horizontal position. The free ends of arms 2 are formed with eyes 3 which form finger-holds whereby the swinging-member may be readily operated and also constitute means for locking the gate or door which may be done on either side thereof by inserting the arm of an ordinary padlock through one of said eyes and through the eye of one of the stops 4 of which there are two, one projecting from each side of the door or gate. The eyes of arms 2 rest on these stops when the swinging-member is in horizontal position so that the gate or door is held from movement in either direction.

The swinging-member is pivotally attached to the fence-post by plates 5 secured to the respective sides of the post and projecting beyond the inner edge thereof where they are formed with openings 6 through which the connecting arm of the swinging-member passes. These plates are inserted on one of the arms 2 of the swinging-member and moved to proper position, one of the eyes 3 being open a slight distance for this purpose.

It will be understood that the positions of the stops 4 and the swinging-member might be reversed, that is, the stops placed on the fence-post and the swinging-member on the gate.

In Fig. 3, I have shown a modification of the swinging-member illustrated in Figs. 1 and 2, the structure being more especially adapted for doors. In this form of the invention one of the arms 2 is formed separate and the connecting-arm 6 with which the other arm 2 is formed integral, is screw-threaded on its outer end. The detachable arm 2 is formed with an eye to receive the screw-threaded end of connecting-arm 6, nuts 7 being positioned on said screw-threaded end on each side of the arm 2. Arm 2 is offset slightly to accommodate the inner one of nuts 7. A hole is drilled in the door or door-jamb and the arm 6 inserted. The detachable arm 2 is then placed on the screw-threaded end of arm 6 and the nuts 7 adjusted. In order to hold arm 2 positively from turning on the arm 6, said arms are provided with key-ways to receive a key 8. It will be seen that in this construction the swinging-member may be readily adjusted to suit the thickness of the door or door-jamb to which it is attached.

In Fig. 4, I have illustrated the device applied to a door or gate which opens in one direction only. In this construction, the detachable arm 9 is shortened to form an operating-handle only, as no retaining-arm is needed on that side of the door or gate.

Instead of forming the stops 4 as shown in Figs. 2 and 3, they might be constructed in the form of a plate 10 having an eye projecting laterally therefrom. The invention is also not limited to the manner shown of pivotally attaching the swinging-member, that is, by the plates 5, as other means might be employed without departing from the spirit and scope of the invention.

Having thus fully described my invention

what I claim as new and desire to secure by Letters Patent of the United States, is:

1. A fastening device for gates and other closures comprising a swinging member carried by one of the parts of the closure having arms to extend on the respective sides of the other part of the closure when said member is swung downwardly, said arms formed at their free ends with eyes, and stops on which said arms rest when swung downwardly having eyes with which the eyes of the arms register whereby the swinging-member may be locked at either side of the closure by inserting a locking device through the registering eyes of the arms and stops.

2. A fastening device for gates and other closures comprising a swinging-member having a pivotal arm to extend through one of the parts of the closure screw-threaded on one end and a locking-arm at its opposite

end formed integral therewith and adapted to extend on one side of the other part of the closure, said arm having an eye formed at its free end, a stop against which said arm rests when swung downward in operative position, said stop formed with an eye with which the eye of the arm registers whereby the closure may be locked by inserting a locking device through the registering eyes of the arm and stop, an operating arm detachably secured to the screw-threaded end of the pivotal arm, and locking nuts for securing the same.

In testimony whereof I affix my signature, in presence of two witnesses.

SAMUEL B. SCHOLZ.

Witnesses:

EVART W. ADAMS,
W. E. JOHNSON.