

(19) World Intellectual Property Organization
International Bureau



(43) International Publication Date
16 February 2006 (16.02.2006)

PCT

(10) International Publication Number
WO 2006/017802 A2

- (51) International Patent Classification:
G02B 6/02 (2006.01)
 - (21) International Application Number:
PCT/US2005/028032
 - (22) International Filing Date: 5 August 2005 (05.08.2005)
 - (25) Filing Language: English
 - (26) Publication Language: English
 - (30) Priority Data:
10/911,812 5 August 2004 (05.08.2004) US
10/912,666 5 August 2004 (05.08.2004) US
 - (71) Applicant (for all designated States except US): NUFERN [US/US]; 7 Airport Park Road, East Granby, CT 06026-9523 (US).
 - (72) Inventors; and
 - (75) Inventors/Applicants (for US only): FARRONI, Julia, A. [US/US]; 84 Dudley Town Road, Windsor, CT 06095 (US). MANYAM, Upendra, H. [IN/US]; 71 Hopmeadow Street, Apt. 11A-2, Weatogue, CT 06089 (US). JACOBSON, Nils [US/US]; 7 Nestor Way, North Granby, CT 06060 (US). TANKALA, Kanishka [US/US]; 30 Andreis Trail, South Windsor, CT 06074 (US). CARTER, Adrian [—/AU]; 19 National Avenue, Bulli, NSW 2516 (AU).
 - (74) Agent: RAINVILLE, Peter, J.; Nufern, 7 Airport Park Road, East Granby, CT 06026-9523 (US).
 - (81) Designated States (unless otherwise indicated, for every kind of national protection available): AE, AG, AL, AM, AT, AU, AZ, BA, BB, BG, BR, BW, BY, BZ, CA, CH, CN, CO, CR, CU, CZ, DE, DK, DM, DZ, EC, EE, EG, ES, FI, GB, GD, GE, GH, GM, HR, HU, ID, IL, IN, IS, JP, KE, KG, KM, KP, KR, KZ, LC, LK, LR, LS, LT, LU, LV, MA, MD, MG, MK, MN, MW, MX, MZ, NA, NG, NI, NO, NZ, OM, PG, PH, PL, PT, RO, RU, SC, SD, SE, SG, SK, SL, SM, SY, TJ, TM, TN, TR, TT, TZ, UA, UG, US, UZ, VC, VN, YU, ZA, ZM, ZW.
 - (84) Designated States (unless otherwise indicated, for every kind of regional protection available): ARIPO (BW, GH, GM, KE, LS, MW, MZ, NA, SD, SL, SZ, TZ, UG, ZM, ZW), Eurasian (AM, AZ, BY, KG, KZ, MD, RU, TJ, TM), European (AT, BE, BG, CH, CY, CZ, DE, DK, EE, ES, FI, FR, GB, GR, HU, IE, IS, IT, LT, LU, LV, MC, NL, PL, PT, RO, SE, SI, SK, TR), OAPI (BF, BJ, CF, CG, CI, CM, GA, GN, GQ, GW, ML, MR, NE, SN, TD, TG).
- Published:**
— without international search report and to be republished upon receipt of that report
- For two-letter codes and other abbreviations, refer to the "Guidance Notes on Codes and Abbreviations" appearing at the beginning of each regular issue of the PCT Gazette.

(54) Title: FIBER OPTIC ARTICLE

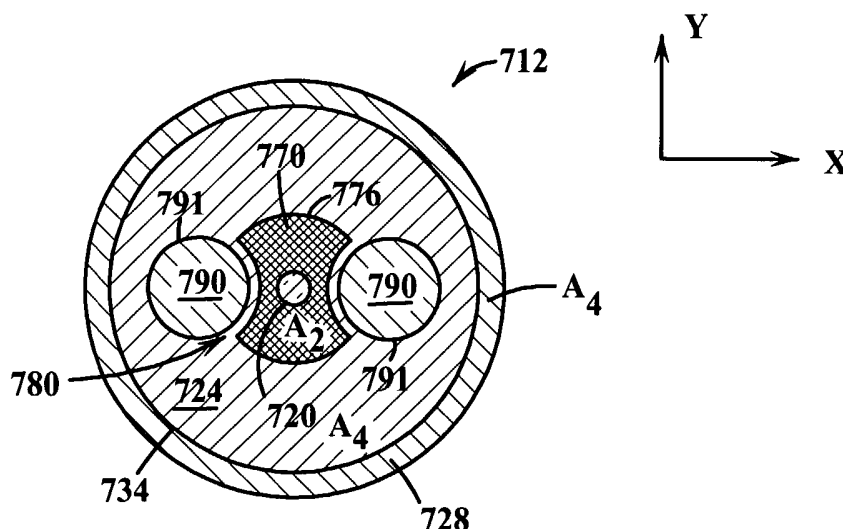

(57) Abstract: An optical fiber comprising a core (120, 220, 320, 420, 520, 620, 720, 820) having at least one rare earth for providing light having a first wavelength responsive to the fiber being pumped by light having a second wavelength that is different than the first wavelength; an inner region (270, 370, 470, 570, 670, 770, 870) disposed about the core; a pump cladding (224, 324, 424, 524, 624, 724, 824) disposed about the inner region; a second cladding (128, 228, 328, 628, 728, 828) disposed about the pump cladding; wherein the index of refraction of the second cladding is less than that of the pump cladding, the index of refraction of the pump cladding is less than that of the inner region, and the index of refraction of the inner region is less than that of the core; and wherein the core comprises a V-number at the first wavelength of greater than 2.405 and wherein the core comprises a numerical aperture of less than 0.12.

WO 2006/017802 A2

10

FIBER OPTIC ARTICLE

Field Of The Invention

The present invention relates to fiber optic articles, such as for example, optical preforms and optical waveguides, such as optical fibers.

15

Background

Fiber optic articles, such as for example, optical fiber preforms or optical fibers, can advantageously include one or more materials, such as, for example, one or more rare earths. The fiber can also include one or more other materials that can enhance the performance of the article, such as by reducing clustering or concentration quenching of the rare earths. Rare earths can be useful in lasers, amplifiers, superfluorescent sources, amplified spontaneous emission (ASE) sources and the like, as they can, in most instances, provide light having a selected wavelength responsive to the article receiving light (e.g., being "pumped" by "pump" light) having a different wavelength. Additionally or alternatively, one or more rare earths can be selected to absorb light.

25

Unfortunately, an optical article comprising one or more materials in the combinations or concentrations required to achieve a desired performance according to a first criterion can result in performance characteristic according to another criterion that is outside a desired range. For example, concentrations of materials desirable in a laser or amplifier to promote efficiency can result in an optical waveguide core having a higher numerical aperture than desired, as most materials known to be added to promote efficiency also raise the index of refraction of the host material (e.g., silica glass) that includes the materials.

30

It is an object of the present invention to address one or more of the deficiencies or disadvantages of the prior art.

Summary Of The Invention

5 In one aspect, the invention provides a fiber optic article having a core and an inner region surrounding the core, where the inner region has inner and outer perimeters spaced by a thickness T_1 therebetween and a first cross sectional area defined as all the area within the outer perimeter of the inner region. The fiber optic article also includes a cladding surrounding the inner region, where the cladding has inner and outer perimeters spaced by a thickness T_2
10 therebetween and the outer perimeter of the cladding has a geometric center. The inner region can have an index of refraction that is less the index of refraction of the core and the cladding can have an index of refraction that is less than the index of refraction of the inner region. T_2 can be greater than T_1 , the outer perimeter of the inner region can be non-circular in shape and the geometric center of the cladding can lie within the first cross sectional area. The outer and
15 inner perimeters of the inner region can define a cross sectional area A_1 therebetween and the outer and inner perimeters of the cladding can define a cross sectional area A_2 therebetween, and A_2 can be greater than A_1 .

 The cladding can consist essentially of fused silica. The fiber optic article can have a
20 longitudinal axis, and the article can comprise at least one longitudinally extending region for providing birefringence. The optical article can comprise a second cladding surrounding the cladding, where the second cladding has an index of refraction that is less than the index of refraction of the cladding. The fiber optic article can be an optical fiber having an operating wavelength at which the fiber supports at least two modes each having an effective index of
25 refraction that is greater the index of refraction of the inner region. The fiber optic article can include at least one rare earth such that responsive to the article being pumped by light having a first wavelength the at least one rare earth can provide light having a second wavelength that is different than the first wavelength, and the operating wavelength can comprise the second wavelength.

30

 In another aspect, the invention can provide a fiber optic article that is elongate along a longitudinal axis and that comprises a core having an index of refraction; an inner region disposed about the core, where the inner region comprises a first index of refraction that is less than the index of refraction of the core and the inner region has an outer perimeter having an

inwardly oriented section; a cladding disposed about the inner region, where the cladding comprising a second index of refraction that is less than the first index of refraction; and at least one longitudinally extending region for providing birefringence. The inwardly oriented region can face the longitudinally extending region. The inwardly oriented region can receive the
5 longitudinally extending region.

The at least one longitudinally extending region can comprise a pair of longitudinally extending regions, and the inwardly oriented section can face one of the longitudinally extending regions and the outer perimeter can include a second inwardly oriented section facing
10 the other of the longitudinally extending regions. The longitudinally extending regions can be diametrically opposed. The inner region can receive each of the longitudinally extending regions. In certain practices, the inner region can support inner region modes, and the longitudinally extending regions can attenuate the inner region modes. The longitudinally extending regions can comprise boron. The article can be an optical fiber having an operating
15 wavelength and the core can be multimode at the operating wavelength.

In yet an additional aspect, the invention can provide a fiber optic article comprising a core; an inner region disposed about the core, where the inner region comprises an inner perimeter and an outer perimeter defining a cross sectional area A_1 therebetween of the inner
20 region; a cladding disposed about the inner region, where the cladding comprises an inner perimeter and an outer perimeter, the perimeters defining a cross sectional area A_2 of the cladding; a second cladding disposed about the cladding; and a third cladding disposed about the second cladding. The index of refraction of the third cladding can be less than that of the second cladding, the index of refraction of the second cladding can be less than that of the
25 cladding, the index of refraction of the cladding can be less than that of the inner region, and the index of refraction of the inner region can be less than that of the core. A_2 can be greater than A_1 .

In an additional aspect, the invention can provide an optical fiber comprising a core
30 comprising at least erbium and ytterbium for providing light having a first wavelength responsive to the fiber being pumped by light having a second wavelength that is different than the first wavelength; an inner region disposed about the core, where the inner region comprises a silica glass; a cladding disposed about the inner region, where the cladding consists essentially of silica; a second cladding disposed about the cladding, where the second cladding comprises

silica glass and at least one index reducing material; a third cladding disposed about the second cladding, where the third cladding comprises a fluorinated polymer; and wherein the index of refraction of the third cladding is less than that of the second cladding, the index of refraction of the second cladding is less than that of the cladding, the index of refraction of the cladding is
5 less than that of the inner region, and the index of refraction of the inner region is less than that of the core, and the core comprises a V-number at the first wavelength of greater than 2.405 and the core comprises a numerical aperture (NA) of less than 0.12. The V-number can be at least 3. The NA can be 0.09 or less. The concentration of erbium can include a concentration of erbium ions and the concentration of ytterbium can include a concentration of ytterbium ions that is at
10 least two times greater than the concentration of erbium ions.

In yet another aspect, the invention can provide a fiber optic article comprising a core comprising a rare earth; an inner region disposed about the core, where the inner region has an index of refraction that is less than that of the core and the inner region has an outer perimeter
15 having a non-circular shape, where the non circular shape is other than an oval shape; a pump cladding disposed about the inner region, where the pump cladding is for receiving pump light for absorption by the rare earth and the pump cladding has an index of refraction that is less than that of the inner region; and a second cladding disposed about the pump cladding, the second cladding having an index of refraction that is less than that of the pump cladding. The core can
20 comprise a concentration of erbium ions and a concentration of ytterbium ions. The concentration of ytterbium ions can be at least twice that of the concentration of erbium ions. The fiber optic article can have a longitudinal axis, and the article can comprise at least one longitudinally extending region for providing birefringence. The article can include a second cladding surrounding the cladding, where the second cladding has an index of refraction that is
25 less than the index of refraction of the cladding. The article can be an optical fiber having an operating wavelength at which the fiber supports at least two modes each having an effective index of refraction that is greater than the index of refraction of the inner region. The operating wavelength can be greater than 500 nm. The operative wavelength can be greater than 900 nm. The fiber can include at least one rare earth such that responsive to the article being pumped by
30 light having a first wavelength the at least one rare earth can provide light having a second wavelength that is different than the first wavelength, and the operating wavelength can comprise the second wavelength.

In yet another aspect, a glass fiber optic article according to the invention can comprise a core including a concentration of erbium, a concentration of fluorine and a concentration of ytterbium for sensitizing the erbium by absorbing pump light and non radiatively transferring energy to the erbium, where the erbium can provide light having a second wavelength different than the wavelength of the pump light; and a cladding disposed about the core, where the cladding having an index of refraction that is less than an index of refraction of the core. The core can comprise phosphorus. The concentration of erbium can include a concentration of erbium ions and the concentration of ytterbium can include a concentration of ytterbium ions that is at least 2 times greater, at least 6 times greater, at least 10 times greater or at least 20 times greater than the concentration of erbium ions. The fiber optic article can comprise a second cladding disposed about the cladding, where the second cladding has an index of refraction that is less than the index of refraction of the cladding. The fiber optic article can be an optical fiber having a V-number of at least 3, at least 4, or at least 6 at the second wavelength. The core can comprise at least 60% or at least 70% by weight of silica. The concentration of fluorine can be at least 1% by weight or at least 3% by weight. The concentration of fluorine can be from 0.1% to 3.5% by weight. The core can comprise a diameter of at least 12 microns or at least 15 microns. In various embodiments the core can have a numerical aperture that is less than 0.12, less than 0.09 or less than 0.06, as noted below.

In yet a further aspect, the invention provides an optical fiber including a core having a concentration of erbium, a concentration of fluorine, a concentration of phosphorus and a concentration of ytterbium for sensitizing the erbium by absorbing pump light and non radiatively transferring energy to the erbium. The erbium can provide light having a second wavelength different than the wavelength of the pump light. The optical fiber can include a cladding disposed about the core and having inner and outer perimeters spaced by a thickness therebetween, where the cladding has an index of refraction that is less than an index of refraction of the core. The core can have a V-number at the second wavelength of greater than 2.405 and a numerical aperture of less than 0.12 relative to the cladding. The thickness can be larger than the thickness of a region, if present, disposed between the cladding and the core.

The cladding can be a pump cladding for receiving the pump light and optical fiber can include a second cladding disposed about the cladding. The concentration of fluorine can be at least 1% by weight. The V-number can be at least 3. In one practice, the numerical aperture is

no greater than 0.09 or is less than 0.09. The core can comprise a diameter of at least 12 microns or at least 15 microns.

5 A fiber optic article according to the invention, such as fiber optic article or optical fiber described herein, can include an inner region, such as may have been discussed, for example, in part in conjunction with certain aspects of the invention noted above. The inner region can comprise a maximum diameter and a minimum diameter, and in one practice of the invention the minimum diameter is not greater than 93% of the maximum diameter. The outer perimeter of the inner region can include at least one inwardly oriented (e.g., concave) section. The outer
10 perimeter of the inner region can comprise at least one outwardly oriented region. The outer perimeter of the inner region can comprise at least one substantially straight section. At least a selected percentage of the length of the outer perimeter of the inner region can conform to a circle having a substantially constant radius. Such a circle can have its center within the outer perimeter of the core. The selected percentage can be, for example, at least 25%, 35%, 50%, or
15 75% of the length of the outer perimeter of the inner region. The selected percentage can represent a majority of the length (i.e., greater than 50% of the length). The outer perimeter of the inner region can have a non-oval shape.

20 A fiber optic article according to the invention, such as any fiber optic article or optical fiber described herein, can comprise a rare earth, as may have been discussed, for example, in part in conjunction with certain aspects of the invention noted above. For example, the core can comprise one or both of erbium and ytterbium.

25 A fiber optic article according to the invention, such as any fiber optic article or optical fiber described herein, can comprise a fiber having an operating wavelength, as may have been discussed, for example, in part in conjunction with certain aspects of the invention noted above. The core can be multimode at the operating wavelength. The operating wavelength can be greater than 500 nm. The operating wavelength can be greater than 900 nm. The operating wavelength can include the wavelength at which a rare earth provides light response to the fiber
30 optic article receiving pump light.

A cladding of a fiber optic article according to the invention, such as, for example, any fiber optic articles or optical fibers described herein, can comprise a glass, as may have been discussed, for example, in part in conjunction with certain aspects of the invention noted above.

A cladding can consist essentially of silica. In one practice of the invention, a second cladding can comprise a glass, which can be a silica glass doped with an index reducing material.

5 The core of a fiber optical article according to the invention, such as, for example, any fiber optic article or fiber described herein, can have a selected numerical aperture (NA), as may have been discussed, for example, in part in conjunction with aspects of the invention noted above. In one practice of the invention, the NA can be less than 0.12; in another practice of the invention, the NA of the core can be less than 0.09; and in yet another practice of the invention the NA of the core can be less than 0.06. In yet an additional practice, the NA of the core can be
10 no greater than 0.1. The cladding can consist essentially of fused silica. Where the fiber has a longitudinal axis and includes a longitudinally extending stress inducing region for providing birefringence, the inner region and the longitudinally extending region can be the same region. Alternatively or additionally, the NA can be greater than 0.01, greater than 0.02 or greater than 0.03.

15

“Fiber optic article”, as used herein, includes both a preform and an optical fiber. Preform can include a completed preform from which an complete optical fiber can be drawn as well as, for example, “partial” preforms that may form just part of the fiber (e.g., a core or a stress rod) and that usually have additional material added to them, or are usually incorporated
20 into a larger preform, before draw. Specific examples may be discussed below in the Detailed Description in terms of an optical fiber or an optical fiber preform. One of ordinary skill in the art, cognizant of the disclosure herein, understands that such descriptions can apply generally to a fiber optic article.

25

Stating herein that one region of a fiber, such as a cladding, has or includes a lower refractive index or index of refraction than another region of a fiber, such as a core, means generally that the region will guide light if it were to be surrounded by the another region (e.g., the core guides light when clad by the cladding). One example is a optical fiber wherein the core and cladding are both formed from a similar material (e.g., silica glass), and one or both of
30 the core and the cladding include material such that the index of refraction of the glass of the cladding is less than the index of refraction of the glass of the core. For example, the core can include germanium, which raises the index of refraction of the silica, and the cladding can consist essentially of silica glass. Also included in the definition of one region having a lower index of refraction than another region are regions that are designed to be microstructured,

holey, photonic bandgap, as well as other designs that can allow for guiding of light. For example, in certain fiber designs, all or some materials of the regions can in fact have the same index of refraction but, for example, one of the regions can have been modified to have a lower effective index of refraction by including air holes to provide an lower average index of refraction or to provide a selected photonic bandgap, such that one of the regions can be disposed about the other of the regions and light can be guided. Such designs are within the scope of the present invention, and within the meaning of one region being stated herein to have a lower index of refraction than another of the regions, as provision is made for guiding of light.

Further advantages, novel features, and objects of the invention will become apparent from the following detailed description of non-limiting embodiments of the invention when considered in conjunction with the accompanying FIGURES. For purposes of clarity, not every component is labeled in every one of the following FIGURES, nor is every component of each embodiment of the invention shown where illustration is not considered necessary to allow those of ordinary skill in the art to understand the invention.

Brief Description Of The Drawings

FIGURE 1 schematically illustrates a cross section of one embodiment of a fiber optic article according to the present invention;

FIGURE 2 schematically illustrates one example of a possible index of refraction profile taken across a selected diameter of the cross section of the fiber optic article of FIGURE 1;

FIGURE 3A schematically illustrates a cross section of a another embodiment of a fiber optic article according to the present invention;

FIGURE 3B is a plot of mode field diameter (MFD) versus a diameter of the inner region for selected fiber optic articles;

FIGURE 4 schematically illustrates one example of a possible index of refraction profile taken across a selected diameter of the cross section of the fiber optic article of FIGURE 3A;

FIGURE 5 schematically illustrates a cross section of yet another embodiment of a fiber optic article according to the present invention;

FIGURE 6 schematically illustrates a cross section of a fiber optic article according to the present invention;

5 FIGURE 7 schematically illustrates a cross section of an additional embodiment of a fiber optic article according to the present invention;

FIGURE 8 schematically illustrates a cross section of yet a further embodiment of an optical fiber according to the present invention;

10

FIGURE 9 schematically illustrates one example of a possible index of refraction profile taken across a selected diameter of the cross section of the optical fiber of FIGURE 8;

15 FIGURE 10 schematically illustrates a cross section of another embodiment of an optical fiber according to the present invention;

FIGURE 11 schematically illustrates a cross section of one more embodiment of an optical fiber according to the present invention; and

20 FIGURE 12 schematically illustrates one example of a possible index of refraction profile taken across a selected diameter of the cross section of the optical fiber of FIGURE 11.

Detailed Description

It is often desirable that a fiber optic article, such as a preform or an optical fiber, 25
comprise a plurality of selected materials so as to provide the fiber optic article with certain capabilities. For example, U.S. Patent 4,666,247, entitled "Multiconstituent Optical Fiber" and issued May 19, 1987 to MacChesney and Simpson, notes that an optical device, such as, for example, a glass (e.g., silica glass) based optical fiber, can beneficially include certain materials. These materials can include the "modifiers" noted in the '247 patent, which can include the 4f- 30
type rare earths. Rare earths can be very useful in fiber lasers, amplifiers and other optical devices. A fiber can advantageously include, in addition to one of the modifiers, a second material, given the name in the '247 patent of a "homogenizer", that can aid in having the optical fiber include a higher concentration of the modifier or that can otherwise enhance the

performance of an optical device that includes one or more modifiers. The '247 patent notes the homogenizers can include elements such as B, Al, Ga, In, P, As, and Sb.

Unfortunately, many of the more desirable modifiers and homogenizers raise the index
5 of refraction of the host material (e.g., silica glass) that includes the homogenizers and/or
modifiers. For example, as a result of including homogenizers and/or modifiers, a core can have
a numerical aperture (NA) that is higher than desired in many circumstances. For example, in
higher power amplifiers and lasers it can be desirable that a fiber have a fundamental mode
having an increased mode field diameter (MFD). The increased MFD can reduce the power
10 density in the fiber and hence delay the onset of nonlinear effects that can limit the ability of the
fiber to handle higher powers. Such nonlinear effects can include stimulated Brillouin scattering
(SBS) and stimulated Raman scattering (SRS). A fiber having a core having a lower NA and/or
a larger diameter can provide a larger MFD that can delay the onset of SBS and SRS. Low NAs
can be desirable for facilitating the attenuation of all higher order modes in amplifiers using a
15 multimode fiber via the technique disclosed in U.S. Patent No. 6,496,301, entitled "Helical Fiber
Amplifier", issued December 17, 2002, to Koplow, Klinner and Goldberg.

Fermann et al. in "Efficient Operation of an Yb-Sensitized Er Fibre Laser at 1.56 μm ",
Electronics Letters, Vol. 24, No. 18, pp. 1135-1136 (1988) teach that an optical fiber comprising
20 erbium and ytterbium can be very useful, as the ytterbium can make pumping the erbium more
practical, and the erbium can provide light at the useful wavelength of, for example, 1560 nm.
In the Fermann et al. article, the core of the fiber includes phosphorus and aluminum in addition
to erbium and ytterbium. In certain instances the NA of such a core can be higher than desired.
For example, the core may not provide the desired larger MFD, especially where the cladding is
25 formed from tube-derived silica glass, as is common in the modified chemical vapor deposition
(MCVD) process for forming the preform from which an optical fiber is drawn.

U.S. Patent No. 6,411,762, entitled "Optical Fiber with Irregularities at Cladding
Boundary", issued June 25, 2002 to Anthon, Emslie, and Maton teaches some techniques for
30 lowering the NA of a single mode core that includes Yb/Er, such as by including an intermediate
region between the core and a cladding, where the intermediate region has a raised index of
refraction for lowering the NA of the single mode core. Multimode (as used herein meaning a
core supporting two or more transverse modes) cores are not addressed.

Vienne et al., in the article entitled "Fabrication and Characterization of $\text{Yb}^{3+}:\text{Er}^{3+}$ Phosphosilicate Fiber for Lasers", Journal of Lightwave Technology, Vol. 16, No. 11, pp. 1990-2001 (1998), provides teaching related to erbium-ytterbium co-doped fibers.

5 FIGURE 1 illustrates one embodiment of a fiber optic article **112** according to the invention. The fiber optical article **112** can include a core **120**, a cladding **124** disposed about the core **120** and a second cladding **128** disposed about the cladding **124**. The core **120** can have a substantially circular outer perimeter **130** that defines the cross-sectional area A_1 of the core **120**. The cladding **124** includes an outer perimeter **134** that defines a cross-sectional area of all
10 the area inside the bounds of the outer perimeter **134**, which cross sectional area may include the cross sectional area of the core. The second cladding **128** can have an outer perimeter **138** that can also be substantially circular. The cladding **124** can contactingly surround, at least in part, the core **120** and the second cladding **128** can contactingly surround, at least in part, the cladding **124**. The core **120** can have a diameter D_{core} .

15

The cladding **124** can include an inner perimeter (which in the embodiment of FIGURE 1 is coextensive with the outer perimeter **130** of the core) that defines with the outer perimeter **134** of the cladding **124** the cross sectional area A_3 therebetween. The second cladding **128** can include an inner perimeter (which in the embodiment shown in FIGURE 1 is coextensive with
20 outer perimeter **134** of the cladding **124**) that defines with the outer perimeter **138** of the second cladding **128** the cross sectional area A_4 therebetween. In one embodiment of the invention, the cross sectional area A_3 is larger than the cross sectional area A_4 .

The inner and outer perimeters of the cladding **124** can be spaced by a thickness T_1 ,
25 where the thickness is to be measured along a radius of the fiber **112**. Similarly, the inner and outer perimeters of the second cladding **128** can be spaced by the thickness T_2 . Where the either or both of the inner and outer perimeters of a region are non circular, the thickness can be different at different locations, and in such as case thickness as used herein refers to the maximum thickness of a region. Typically the thickness T_1 is greater than the thickness T_2 . For
30 clarity the thickness of various regions may not be shown in all the FIGURES herein; however, the concept as explained in conjunction with FIGURE 1 apprises one of ordinary skill how it applied to regions of the other fiber optic articles described and shown herein.

A perimeter, such as the outer perimeter **134** of the cladding **124**, can be defined by a set of points in the cross sectional plane, where each point has a particular x and y coordinate. The geometric center of a perimeter is the x, y point given by the average x coordinate of all the x coordinates of the outer perimeter and the average y coordinate of all the y coordinates of the outer perimeter

The fiber optic article **112** can comprise one or more active materials for providing light having a first wavelength responsive to the fiber receiving (e.g., being “pumped by”) light having a second wavelength (e.g., “pump” light) that is different than the first wavelength. The active material can include one or more rare earths, such as, for example, one or more of the Lanthanide elements of the periodic table (e.g., elements having atomic numbers from 57 to 71). Erbium, neodymium, thulium and ytterbium are all understood to be particularly useful in optical devices, such as, for example, fiber lasers, amplifiers, amplified spontaneous emission (ASE) or superfluorescent sources. “Providing light” includes light provided by stimulated emission or spontaneous emission as electrons decay from the higher energy levels to which they have been excited by the pump light and emit photons. Stimulated emission can occur responsive to provision of an external signal or seed beam, such as in certain types of optical amplifiers, as well as stimulated emission provided in certain types of lasers and other devices, where no external signal is necessary and light provided by spontaneous emission can initiate operation of the device. When erbium and ytterbium are both present in the proper arrangement (e.g., relative concentrations, placement in the fiber, etc.) the ytterbium can sensitize the erbium, meaning that the ytterbium absorbs pump light having a first wavelength and transfers energy to the erbium, such as by a non-radiative process, such that the erbium provides light. The light can have a second wavelength that is different than the first wavelength. Note that the term “light” as used herein generally means electromagnetic energy regardless of wavelength, and is not limited to light having a wavelength within the visible spectrum.

The core **120** and the cladding **124** can each guide light. Typically the cladding **124** guides light (e.g., pump light). In one embodiment of the invention, the cladding **124** can comprise an index of refraction n_{clad} that is less than an index of refraction n_{core} of the core **120**, and the second cladding **128** can comprise an index of refraction n_{clad2} that is less than the index of refraction n_{clad} of the cladding.

The second cladding **128** can comprise a glass, such as, for example, a silica glass, and can include an index reducing material, such as, for example, fluorine or boron. The second cladding **128** can comprise a polymer, such as, for example, an acrylate polymer, which can be fluorinated. Note that a fiber according to the invention, such as the fiber **112**, can also include
5 another region **140**, which can be a protective region that comprises an acrylate polymer applied to the fiber as it is drawn from a preform. The another region **140** can be disposed about the second cladding **128**. Where the second cladding **128** comprises an acrylate polymer, such as a fluorinated polymer, the protective region **140** can often be omitted, as the second cladding **128** can also play a protective role. Note also that in some instances the second cladding **128** can be
10 omitted. This can make pumping the fiber **112** more difficult and/or more expensive, but techniques are known in the art (e.g., end pumping the core using low divergence pump sources and dichroic and/or focusing optical elements).

As is known in the art, the cladding **124** can be adapted to receive the pump light to
15 pump the one or more active materials comprised by the optical fiber **112**. Typically the cladding is multimode at the pump wavelength. Also, the ratio of the cross sectional area defined by the outer perimeter **134** of the cladding **124** to the cross sectional area of the core **120** (i.e., the cross sectional area defined by the outer perimeter **130** of the core **120**) is typically at least 10; at least 50; at least 100 or even at least 1000.

20

The outer perimeter **134** of the cladding **124** is typically non circular so as to scatter pump light received by the fiber to increase the absorption of the pump light by the active material, such as by disrupting skew rays. In FIGURE 1 the outer perimeter **134** of the cladding **124** has an octagonal shape. Many other shapes are possible, as is known by one of ordinary
25 skill in the art.

As noted in the aforementioned U.S. Patent No. 6,411,762 entitled "Optical Fiber with Irregularities at Cladding Boundary", issued June 25, 2002 to Anthon, Emslie and Maton, a fiber can advantageously include erbium and ytterbium (e.g., erbium ions and ytterbium ions) and
30 another material, such as phosphorus, that can enhance the efficiency of pumping the Yb/Er. The '762 patent is incorporated by reference herein to the extent that it is necessary to understand the present invention and does not conflict with the teachings herein.

Accordingly, a region of the fiber **112** (e.g., the core **120** of the fiber **112**) can comprise a concentration of Yb, a concentration of Er, a concentration of a selected material that increases pumping efficiency and a concentration of a second selected material (e.g., fluorine) that reduces the index of refraction of the host material to which the aforementioned materials are added.

5 The selected material may change (e.g., raise) the phonon energy of the host material for increasing the pumping efficiency. The host material can comprise a host glass, such as a silica glass that is, for example, at least 50%, at least 60%, at least 70% or at least 85% silica by weight. The core can comprise, consist of, or consist essentially of Yb (e.g., in the form of Yb_2O_3), Er (e.g., in the form of Er_2O_3), the selected material (e.g., phosphorus in the form of P_2O_5) and the second selected material (e.g., fluorine). Typically the selected material will raise
10 the index of refraction of the host material. In certain circumstances, other materials, such as, for example, germanium can also be included in the same region of the fiber (e.g., the core) as the aforementioned materials (e.g., Yb, Er, P and F).

15 Addition of fluorine to the core of the fiber can help lower the NA of the core. As is understood by one of ordinary skill in the art, the NA of a fiber is related to the acceptance angle of the fiber by the formula $\text{NA} = \sin \Theta_{\text{max}}$, where Θ_{max} is the maximum angle of incidence for a ray that will be guided by the fiber. For a fiber having a first region having a step refractive index profile relative to a second region (e.g., the core relative to the cladding or first cladding
20 relative to a second cladding) the NA can be approximated according to the formula:

$$\text{NA} = [(\text{refractive index of first region})^2 - (\text{refractive index of second region})^2]^{1/2}$$

The NA can also be measured experimentally, and measurements are preferably made to
25 determine whether a fiber has an NA as specified herein, as the above formula is for an ideal step refractive index profile, whereas a measurement can be made on many different types of fibers (e.g., photonic bandgap fibers, which are included within the scope of the invention). Stating herein that one region of the fiber has a selected NA relative to another region of fiber means the NA obtained when the regions are adjacent such that any intervening region has little
30 or no effect of the NA determination. Regions need not be adjacent for the forgoing to be a useful definition.

A region (e.g., the core) of a fiber according to the invention, such as the fiber **112** of FIGURE 1 or any of the other fibers taught herein, may comprise a numerical aperture (NA) of

less than 0.12; of no greater than 0.09; of no greater than 0.08; of no of no greater than 0.07; of no greater than 0.06; and of no greater than 0.05. In conjunction with any of the foregoing, it is noted that the NA can be at least 0.01, at least 0.02, or at least 0.03. The NA can also be from 0.05 to 0.11; from 0.06 to 0.11; from 0.07 to 0.11; or from 0.08 to 0.11. Other possibilities
5 include a NA from 0.06 to 0.08; or from 0.05 to 0.09. The concentration of the second selected material, which reduces the index of refraction, may be selected at least in part to achieve the desired NA. Note that the NA of the core **120** can in certain circumstances actually be the NA of the core **120** relative to the cladding **124**, and that in some embodiments of the invention the “pedestal” region of the aforementioned U.S. Patent No. 6,411,762, disposed between the
10 cladding **124** and the core **120** is not used to achieve a particular NA. The use of fluorine can help reduce the need for a “pedestal” or a pedestal to be of less consequence (e.g., not having as high index of refraction relative to a cladding).

The cladding **124** of the fiber **112**, which may correspond to the second region in the
15 above equation, can comprise fused silica. The cladding **124** can consist of or consist essentially of fused silica.

Typically the fiber (e.g., the core of the fiber) will comprise from 10% to 25% by weight of P_2O_5 ; from 0.5% to 5% by weight of Yb_2O_3 ; from 0% to 0.7% by weight of Er_2O_3 ; and from
20 0.1% to 3.5% by weight of F. In certain embodiments, the fiber (e.g., the core) can comprise 5% to 12.5% by weight of P_2O_5 , or, in other embodiments, no greater than 7.5%, no greater than 10%, no greater than 12.5%, no greater than 15%, no greater than 17.5%, or no greater than 20% by weight of P_2O_5 , such as in combination with the foregoing concentrations of other materials. In certain embodiments, a fiber optic article (e.g., the core of an optical fiber) can comprise at
25 least 1%, at least 3%, or at least 5% by weight of fluorine, such as, for example, in combination with the foregoing concentrations of other materials. A glass host material, (e.g., SiO_2) typically makes up any remainder of one or more of the foregoing. The core may be essentially free of aluminum. In one embodiment of the invention, the fiber (e.g., the core of the fiber) can
30 comprise from 0 to 4.9×10^{19} erbium atoms (e.g., Er^{3+} ions) per cubic centimeter and from 3.3×10^{19} to 3.4×10^{20} ytterbium atoms (e.g., Yb^{3+} ions) per cubic centimeter. Such a fiber can also include a concentration of phosphorus, which can be incorporated into a compound, such as, for example, P_2O_5 , in the concentrations noted above. The fiber can also include F in concentrations noted above. Typically, the concentration of ytterbium atoms or ions is higher than the concentration of erbium atoms or ions. The ratio of ytterbium ions to erbium ions can

be, for example, at least 2:1, at least 6:1, at least 10:1; at least 12:1, at least 15:1; or at least 20:1. The ratio of ytterbium ions to erbium ions can, in certain embodiments, be no greater than 2:1; no greater than 6:1; no greater than 10:1; no greater than 12:1; no greater than 15:1, or no greater than 20:1. The concentration in weight percent of Er_2O_3 is typically lower than the
5 concentration in weight percent of Yb_2O_3 .

A preform from which a fiber according to the invention can be drawn can include one or both of phosphorus and fluorine added to the preform via Modified Chemical Vapor Deposition (MCVD) or other techniques known in the art, such as Plasma Assisted Deposition or Outside
10 Vapor Deposition (OVD). The one or more rare earths, such as the erbium and ytterbium, can be included in the preform via Solution Doping, where an appropriate frit (e.g., a frit that includes a silica host material and possibly phosphorus and/or fluorine) is deposited via the MCVD or other technique. Solution doping is known in the art and is not further described herein.

15
FIGURE 2 schematically illustrates one example of a possible index of refraction profile 150 taken across a selected diameter of the cross section of the optical fiber 112 of FIGURE 1. The index of refraction profile 150 includes a section 152 corresponding generally to the core 120 and hence representing n_{core} ; sections 156 corresponding generally to the cladding 124 and
20 hence representing n_{clad} ; and sections 158 corresponding generally to the second cladding 128 and hence representing n_{clad2} .

FIGURE 3A schematically illustrates a cross-section of a second embodiment of a fiber optic article according to the present invention.

25
The fiber optic article 212 of FIGURE 3A includes an inner region 270 disposed about the core 220 and having an outer perimeter 276. The inner region 270 comprises an index of refraction n_{reg} , wherein $n_{\text{reg}} < n_{\text{core}}$; $n_{\text{clad}} < n_{\text{reg}}$; and $n_{\text{clad2}} < n_{\text{clad}}$. The article 212 can be a fiber and one or more of n_{core} , n_{reg} and the diameter D of the inner region 270 can be selected such
30 that the inner region 270 serves as a cladding for the core 220 and the fiber propagates at least one core mode at the first wavelength, where "core mode" means an LP_{xx} mode wherein the effective index of refraction of the mode is higher than the effective index of refraction of the inner region 270. The calculation of an effective index of refraction for a mode is a well-known technique in the art. Calculations can be made using software, such as the FIBER_CAD

OptiFiber Optical Fiber Design Software (version 1.5) available from Optiwave Corporation, 16 Concourse Gate, Suite 100, Nepean Ontario K2E 7S8, Canada, or according to other techniques using the mathematical models (or equivalents) used in the FIBER_CAD OptiFiber Software.

5 In one embodiment the core **220** is single moded at the operating wavelength of the fiber; in another embodiment the core **220** is multimode at an operating wavelength of the fiber. Specifying herein that a fiber is single mode or multimode refers to how the fiber will perform absent external influences (e.g., absent coiling to a radius to highly attenuate all higher modes, such as is taught in the aforementioned U.S. Patent No. 6,496,301, entitled "Helical Fiber
10 Amplifier", issued December 17, 2002, to Koplow, Kliner and Goldberg. Note that in one embodiment of the fiber optic article **112** of FIGURE 1, the fiber optic article does not include the inner region described in conjunction with FIGURE 2.

 The fiber optic article **212** can include a cladding **224** disposed about the inner region
15 **270**. A second cladding **228** can be disposed about the cladding **224**. The fiber optic article **212** can also comprise another region **240** disposed about the second cladding **228** and having an outer perimeter **248**. The region **240** can be a third cladding having an index of refraction n_{clad3} that is less than n_{clad2} , which is in turn less than n_{clad} , which is in turn less than n_{reg} , which is less than n_{core} . It can be advantageous to include an additional cladding, especially where a fiber
20 according to the invention will receive higher levels of pump power. Additional claddings can share the duty of confining the pump power. For example, in one embodiment of the invention, the cladding **224** can comprise undoped fused silica, or can consist essentially of or consist of fused silica. The cladding **224** can be derived, for example, from a commercially available silica tube that can be part of the preform from which the fiber is drawn. Such tubes are available
25 from vendors such as Heraeus Amersil. The second cladding **228** can comprise "down doped" fused silica, such as silica glass that is doped with fluorine, or can consist essentially of or consist of fluorine-doped silica. The second cladding **228** can be derived, for example, from a fluorinated silica glass tube that can be part of the preform from which the fiber is drawn. Fluorinated glass tubes are also understood to be available from Heraeus Amersil.

30

 The region **240** can be a third cladding that comprises a polymer, such as, for example, a fluorinated polymer, which can be added as a coating to the fiber as the fiber is drawn from a preform, as is known in the art.

Note that the perimeter **234** of the cladding **224** of the fiber optic article **212** is shown in FIGURE 3A as substantially circularly shaped. In general the perimeter **234** can be non-circularly shaped, and can be shaped as an octagon, as in FIGURE 1.

5 The thicknesses T_1 of the inner region **270** and T_2 of the cladding **224** are shown. T_2 is typically greater than T_1 . The outer perimeter **230** of the core **220** can define the cross sectional area A_1 ; the outer and inner perimeters of the inner region **270** can define the cross sectional area A_2 therebetween; the outer and inner perimeters of the cladding **224** can define the cross sectional area A_3 therebetween; and the outer and inner perimeters of the second cladding **228**
10 can define the cross sectional area A_4 therebetween.

FIGURE 3B illustrates a plot of the mode field diameter (MFD) of a selected LP mode (e.g., the LP_{01} mode) versus a diameter of the inner region **270** (e.g., the diameter D of the outer perimeter **276** as shown in FIGURE 2) for three optical fiber designs (fibers 1, 2 & 3), and a
15 table summarizing certain features of the three fibers. Note that the change in the MFD tends to decrease as the diameter D of the outer perimeter **276** of the inner region increases. Several parameters are noted in the table of FIGURE 3B. The "Core NA" and "Inner Region NA" listed in table are calculated relative to the index of refraction of the cladding **224**, which for the calculations is assumed to consist essentially of silica. The "Effective core NA" listed in the
20 table is the calculated NA of the core relative to the inner region based on the indices of refraction thereof, and the "Effective V Number" is V as calculated based on the Effective Core NA. The "Clad NA" is the NA of the clad relative to a second cladding, which is assumed to be a fluorinated polymer acrylate for the purposes of the calculations. The value noted in the table for "Inner Region Diameter" is a diameter (diameter D_1) of the inner region wherein, for an
25 increase in the diameter of the inner region **276**, the attendant increase in the MFD of a selected mode (e.g., the LP_{01} mode) is no greater than a selected percentage of the MFD at the diameter D_1 . In various embodiments of fiber optical articles according to the invention, the selected percentage can be, for example, 5%, 2.5%, 1%, or 0.5%. Preferably the selected percentage is no greater than 0.5%. The arrows in the plot correspond generally to the diameters in the table
30 under the heading "Inner Region Diameter". For the diameters noted in the table, the percentage change in MFD is understood to be less than the preferred value of 0.5%. Note that the diameter listed under the heading "Inner Region Diameter" generally increases as the value listed under "Effective Core NA" decreases. The specific fibers of the table and plot of FIGURE 3B are exemplary and represent more generally a design approach that can be applied to other fiber

within the scope of the invention and not specifically described in FIGURE 3B. For purposes of determined whether the MFD is varying with changes in a diameter of the inner region it is considered that actual measurements can be made of a number of fibers having different sized inner regions (the inner region should be proportionally scaled up in size if it has a non circular outer perimeter). The MFD diameter can be measured using a Spiricon Model LBA-300 Beam Analyzer or equivalent, where the $1/e^2$ power points are used to determine the MFD, as is common in the art.

FIGURE 4 schematically illustrates one possible refractive index profile **250** for the fiber optic article **212**, where the refractive index profile **250** is taken along a selected diameter of the cross section shown in FIGURE 3A, such as a diameter along a selected one of the x and y axes. The refractive index profile **250** comprises a inner section **252**, which can correspond to the core **220**, sections **254**, which can correspond the inner region **270**, sections **256**, which can correspond to the cladding **224**, sections **258**, which can correspond to the second cladding **228**, and sections **260**, which can correspond to the third cladding **240**. The sections **260** can also be raised, as in indicated by reference numerals **260A**, such as when the region **240** comprises an acrylate polymer having an increased index of refraction.

FIGURE 5 illustrates another embodiment of a fiber optic article **312** according to the present invention. The fiber optic article **312** can comprise a core **320**, an inner region **370** disposed about the core **320**, a cladding **324** disposed about the inner region **370**, and a second cladding **328** disposed about the cladding **324**. The perimeter **376** of the inner region **370** can be non-circular, such as, for example, by including inwardly oriented lengths **380**. The outer perimeter **376** of the inner region **370** can also include lengths, such as length **382**, wherein the length can be defined by a substantially constant radius of curvature, such that the length **382** substantially conforms to a portion of a circle. The substantially constant radius of curvature can be about a center (from which the radius emanates) that is located within the outer perimeter **376** of the inner region **370**, and preferably within the outer perimeter of the core **320**, such as by being located substantially at the center of the core **320**. It can be advantageous that the majority of the length of the outer perimeter **376** and/or the length of the outer perimeter **334** conform to a circle having its center located within the core **320**.

When the fiber optic article **312** is a fiber, the non-circular perimeter **376** may help scatter any pump light that enters the inner region **370** to help ensure more efficient absorption

of the pump light by rare earth comprised by the fiber 312. The outer perimeter 334 of the cladding 324 can also be non-circular in shape, such as, for example, by having D-shape shown in FIGURE 5. The outer perimeter 334 of the cladding 324 can include the substantially straight section 384, as indicated FIGURE 5.

5

FIGURE 5 illustrates the cross sectional areas A_1 , A_2 , A_3 and A_4 , which can be defined as indicated in conjunction with the discussion of FIGURES 1 and 3A.

FIGURE 6 can be useful in describing one technique for fabricating a fiber optic article 10 312 having an inner region 370 having a non-circular outer perimeter 376. Consider that reference numeral 412 represents at least part of an optical fiber preform from which at least part of a fiber 312 can be drawn. The preform can include a core portion 420; an inner region portion 470; and a cladding portion 424. The core portion 420 and inner region portion can be deposited, such as by the MCVD process, on the inside of a silica tube that is then collapsed, 15 where the tube forms at least part of the cladding portion 424. A rod 486 can be inserted into a hole drilled into the preform, where the hole is drilled into at least part of the inner region portion 470. The rod 486 can comprise an index of refraction that is different than at least the index of refraction of the part of the inner region portion that is nearest to the rod 486. The outer perimeter 482 of the inner region portion 470 can include the inwardly oriented section 480. 20 The rod 486 can comprise an index of refraction that is substantially the same as an index of refraction comprised by the cladding portion 424. In one embodiment of the invention the rod comprises an index of refraction that is less than an index of refraction comprised by the cladding portion 424.

25

An inner region of an optical fiber according the invention can comprise a second inner region part 585 disposed about a first inner region part 583, as schematically illustrated in cross section in FIGURE 7. For example, the core of an optical fiber of the invention, such as the core 520, can comprise phosphorus, erbium and ytterbium, where the phosphorus can reduce backtransfer of energy from the erbium to the ytterbium and thus increase the efficiency of the 30 optical fiber. Typically, however, the NA of the core would be much higher than is desired (relative to pure fused silica) due to one or more of the foregoing materials raising the index of refraction of a host glass material, such as silica glass. The inner region 570 comprises an index of refraction that is greater than an index of refraction comprised by the cladding 524 so as to lower the NA of the core 520. Although in theory the inner region could be omitted and the

index of refraction of the whole cladding **524** could be raised to reduce the NA of the core **520**, this is difficult in practice due to the amount of material than must be deposited when processes such as MCVD are used to fabricate all or part of a preform from which the optical fiber is to be drawn.

5

The inner region **570** can include an inner part **583** that may be different from an outer part **585** of the inner region **570**. In some embodiments the difference can be described in terms of the constitution of each of the parts. For example one of the parts can include a material (e.g., a dopant, such as germanium) not included in the other of the parts or, more generally, can include a concentration of a material that is different than the concentration comprised by the other of the parts. In other embodiments the difference can be described in terms of a characteristic of the part, such as hardness or glass transition temperature.

For example, in one embodiment of the invention the outer part **585** of the inner region **570** can comprise a harder material (e.g., a harder glass) than the inner part **583** of the inner region **570**, which will typically also comprise a glass. Such an arrangement can help maintain the shape of the outer perimeter **576** of the inner region **570** during drawing of the fiber from a preform. The inner part **583** can comprise, consist of, or consist essentially of a host glass, such as, for example, a silica glass, and phosphorus (P), and the outer part **585** can comprise, consist of, or consist essentially of a host glass, such as, for example, a silica glass, and P and another material, such as for, example, germanium (Ge). Thus one of the parts of the inner region **570** can comprise a selected material of which the other part is essentially free, or one of the parts of the inner region **570** can comprise a substantially different concentration (i.e., not a difference attributable to process variations where the intent is to have the concentrations be the same) of the selected material than the other of the parts.

Both of the foregoing can be applicable. For example, the inner part **583** can include a first selected material (e.g., P in the form of P_2O_5) that is also included in the outer part **585** but in a substantially different concentration (e.g., the inner part **583** can comprise 10-20 weight % of P_2O_5 and the outer part can comprise 0-10 weight % of P_2O_5 and the outer part **585** can comprise a second selected material (e.g., 0-10 weight of GeO_2) of which the inner part **583** is substantially free. Preferably, the inner part **583** of the inner region **570** comprises an index of refraction that is substantially the same as an index of refraction comprised by the outer part **585**

of the inner region **570**. This can be achieved by proper selection of the concentrations of the material in each of the inner and outer parts of the inner region **570**.

5 The inner region **570** can have an index of refraction that is substantially the same throughout the inner region **570**, such that the inner region is considered by one of ordinary skill in the art to comprise a “step” in the index of refraction profile of the fiber.

10 The inner part **583** can be closer in composition to the core **520** than the outer part **585**, which is closer in composition to the cladding **524** than the inner part **583**. The inner part **583** can comprise a higher internal stress than the outer part **585**. Lower internal stress in the outer part **585** can facilitate drilling of the hole that receives rod **486** shown in FIGURE 6.

15 The inner region (e.g., the inner region **370** of FIGURE 5) can be non-circular and can have a maximum diameter and a minimum diameter. The minimum diameter can be no greater than 50%, no greater than 60%, no greater than 70%, no greater than 80%, no greater than 90%, or no greater than 93% of the maximum diameter. In one practice of the invention the minimum diameter is from 80% to 95% of the maximum diameter. The outer perimeter of an inner region can be non-circular and non-oval.

20 The inner region **570** (e.g., the outer part **585** of the inner region **570**) of an optical fiber according to the present invention can include an attenuating material for selectively attenuating, relative to core modes, modes having power (e.g., 25% or greater of the total power of the mode) outside of the cross section of the core **520**. The attenuating material can be a wavelength selective material for selectively attenuating a first wavelength relative to the pump wavelength
25 (e.g., cobalt, terbium or the like, which can be appropriate when the fiber includes erbium and ytterbium). Selectively attenuating means that the attenuation of light having the first wavelength is higher than the attenuation provided by the material for light having the pump wavelength. Preferably the attenuation is significantly higher. The outer part **585** can include the wavelength selective material and the inner part **583** of the inner region **570** can be
30 substantially or essentially free of the wavelength selective material. U.S. Patent No. 6,278,816, entitled “Noise Reduction Technique for Cladding Pumped Optical Amplifiers”, issued August 21, 2001, which is a continuation-in-part of the aforementioned ‘762 patent, includes some teaching related to materials for providing wavelength selective attenuation.

In another embodiment, the inner region 570 of an optical fiber according to the present invention is not adapted to selectively attenuate inner region modes relative to a core mode or modes. For example, in one embodiment the outer region 585 does not comprise an attenuating material or a wavelength selective attenuating material for selectively attenuating inner region modes and/or light having a first wavelength (e.g. the wavelength at which an active material provides light) relative to light having the pump wavelength.

The areas A_1 , A_2 , A_3 and A_4 (applicable when a second cladding is present) are not shown in FIGURES 6 and 7, but can be defined as indicated in conjunction with the discussion of FIGURES 1 and 3A.

The range of wavelengths at which fiber lasers and amplifiers can efficiently operate can be limited compared to other types of lasers and amplifiers. It can be desirable to convert light from a fiber device to another more useful wavelength.

Light is an electromagnetic wave in which the electric field can oscillate along a direction that is perpendicular to the direction in which the light propagates. For example, if the electric field vibrates along the horizontal axis, the light is said to be horizontally polarized; if the light vibrates along the vertical axis, the light is said to be vertically polarized. Optical fiber typically propagates light in two orthogonal polarizations (i.e., both vertical and horizontal) for each mode propagated by the fiber. The light can couple back and forth from one polarization to the other as the light propagates along the fiber, such that the polarization of the light emanating from the fiber is a mixture of both vertical and horizontal polarizations and is thus not controlled. Proper control of the polarization, however, can be important in many applications.

In one practice of the invention, a fiber can include a selected birefringence, such as, for example, a selected birefringence at the wavelength of operation of the fiber. Birefringence can help to provide an optical fiber with polarization maintaining or polarizing properties, which can be useful in controlling the polarization of the light propagated by the fiber. For example, coupling between orthogonal linear polarizations is inevitable in a practical fiber. Providing a fiber with sufficient birefringence, such that the light in one of the polarizations has a different phase velocity and/or wavelength than light in the other of the polarizations, can reduce any constructive superposition of light undesirably coupled into one linear polarization from the orthogonal (and desired) polarization at various locations along the length of a fiber.

FIGURE 8 illustrates an additional embodiment wherein a fiber optic article, such as the fiber optic article 112 of FIGURE 1, includes longitudinally extending regions for providing birefringence, such as by providing a sufficient refractive index change or by inducing stress in all or part of a selected region of the optical fiber. The fiber optic article 612 includes a core 620 and can further include an inner region 670 disposed about the core 620. The fiber optic article 612 includes a cladding 624 disposed about the core 620 and a second cladding 628 disposed about the cladding 624. The fiber optic article 612 includes a pair of longitudinally extending regions 690, where the longitudinal axis is the axis along which the fiber is elongate. FIGURE 8 illustrates a "panda" style fiber where each of the regions 690 has a substantially circular outer perimeter 691. Other designs, such as the "bowtie" design, wherein the stress inducing regions have non-circular outer perimeters, are also within the scope of the invention. The longitudinally extending regions 690 can each have a thermal coefficient of expansion (TCE) that is different than the TCE of at least part of a region (e.g., the cladding 624) of the fiber 612 that is disposed about the longitudinally extending regions 690. Because the TCEs of the regions 690 and the cladding 624 are different, a stress is induced in all or part of a region or regions of the fiber, such as, for example, the core 620, when the fiber cools after being drawn, such as when being drawn from a heated preform. The stress can introduce a selected birefringence (i.e., different refractive indices for the orthogonal linear polarizations) due to the stress-optic effect. Birefringence can be introduced to the fiber 612 in other ways, in addition to or alternatively to the use of the longitudinally extending stress inducing regions 690. For example, the core 620 can have an elliptical cross section, as is known in the art. Also, the longitudinal region can provide a selected change in effective refractive index along a selected axis of the fiber in addition or alternative to inducing stress in the fiber optic article. The inner region 670 can be omitted. The core of the fiber optic article can include materials and concentrations thereof noted in conjunction with the discussion of FIGURE 1.

The birefringence is a function at least of the diameter D_{sr} of the regions 690, the spacing S between the longitudinally extending regions 690 and the core 620, and the difference between the TCE of each of the longitudinally extending regions 690 and the TCE of the regions of the fiber disposed about the longitudinally extending regions 690 such as, for example, the TCE of the inner cladding 624. Increasing the diameter D_{sr} , decreasing the spacing S between the longitudinally extending regions 690 and the core 620, and increasing the difference between the TCEs of the longitudinally extending regions 690 and the TCE of the inner cladding 624 all

increase the birefringence. As is understood by one of ordinary skill in the art, the longitudinally extending regions typically comprise one or both of boron and phosphorous, typically in the form of one or more of B_2O_3 , P_2O_5 , or BPO_4 , although other dopants can be used. For example, germanium (e.g., as GeO_2) aluminum (e.g., as Al_2O_3) and titanium or
5 fluorine can also be used to help provide a desired TCE. The foregoing materials can be used alone or in combination. For example, increasing the amount of boron and/or phosphorus comprised by the longitudinally extending regions 690 typically increases the birefringence of the optical fiber.

10 Because phosphorus and boron have opposite effects on the index of refraction of a host glass, such as a host glass that comprises silica, the longitudinally extending regions 690 can comprise an index of refraction that can be selected substantially independently of the TCE of the stress inducing region.

15 Preferably, the longitudinally extending regions 690 have an index of refraction that is lower than the index of refraction of the inner cladding 624 such that the longitudinally extending regions 690 do not guide light. Suitable index differences between one or both of the longitudinally extending regions 690 and the inner cladding 624 can range from 0.005 to 0.015. One typical index difference found to be useful is out 0.01.

20

Longitudinally extending regions for inducing stress are well known in the art and the proper composition for achieving the particular TCE and hence inducing a particular stress in the fiber are also well known and only briefly discussed here. See, for example, the thesis of Bent Edvold entitled "Polarization Maintaining Fibers", Electromagnetics Institute, Technical
25 University of Denmark, EF-402, April, 1994. Tankala et al. have described in detail the theoretical, geometrical and manufacturing considerations for providing a fiber with birefringence, particularly with reference to polarization maintaining double clad fibers (see for example K. Tankala, A. Carter, D.P. Machewirth, J. Farroni, J. Abramczyk and U.H. Manyam, SPIE proc v. 4974, p 220, 2003, incorporated herein by reference). The foregoing are
30 incorporated by reference to the extent necessary to understand the present invention and to the extent that they do not conflict with the teachings herein. See also patents relating to polarization maintaining fibers, such as, for example, patents from Corning Glass Works of Corning, N.Y., which is well known for developing fibers designed to have selected birefringence and hence be polarization maintaining or polarizing.

More particularly, see U.S. Patent No. 4,395,270, entitled "Method of Fabricating a Polarization Retaining Single-Mode Optical Waveguide", filed April 13, 1981 and issued July 26, 1983 to Blankenship and Keck. See also U.S. Patent No. 4,478,489, entitled "Polarization Retaining Single-Mode Optical Waveguide", filed March 28, 1983 and issued October 23, 1984 to Blankenship and Keck, as well as U.S. Patent No. 4,561,871, entitled "Method of Making Polarization Preserving Optical Fiber", filed December 27, 1983 and issued December 31, 1985 to Berkey. In addition, see U.S. Patent No. 5,152,818, entitled "Method of Making Polarization Retaining Fiber", filed November 9, 1990 and issued October 6, 1992 to Berkey, Bhagavatula, Hawk and Tarcza. See in addition U.S. Patent No. 4,896,942, entitled "Polarization-Maintaining Optical Fiber", filed February 3, 1989 and issued January 30, 1990 to Onstott, Messerly, Mikkelson and Donalds. Publications include G.B. Patent Application 2,012,983 A, entitled "Optical Waveguides Having Non-Uniform Outer Jackets", published August 1, 1979 in the names of Kaminow, Pleibel, Ramaswamy and Stolen; Hosaka et al., Electronics Letters, 17, 191 (1981); Hosaka et al., Electronics Letters, 17, 631 (1981); and D. Kliner et al., Optics Letters 26, 184 (2001).

As noted above, polarization maintaining fibers typically use birefringence to reduce the effect (e.g., constructive superposition) of any coupling between orthogonal linear polarizations. Typically, this means that a PM fiber is designed to have as high a birefringence as possible. Fibers having increased birefringence are typically one or more of more expensive and more difficult to manufacture than fibers having lower birefringence. However, coupling between polarizations can be reduced such that increased birefringence is supposedly not as necessary. See published U.S. Patent Application US 2002/0172486 A1, which indicates that the diameter of an optical fiber can be selected to reduce coupling between polarizations.

A polarizing fiber can also use birefringence. For example, in one approach, birefringence is introduced into both the core and the cladding, with the core having a higher birefringence than the cladding, and such that one of the polarizations has a larger mode field diameter and is sufficiently more susceptible to bend loss. In another approach, the index of the core and cladding are equal for one of the polarizations, such that the one polarization is not guided. In another approach, the birefringence of the core and cladding are equal, but the mode for one of the polarizations is "leaky" because it has a small component along the direction of

the other polarization which sees loss, as the fiber is designed such that the effective index for the one polarization is lower than the index of refraction for the other polarization.

In yet a further approach, a polarizing fiber can include absorptive stress inducing regions. In an additional approach, a “W” shaped refractive index profile allows one of the polarizations to “tunnel” through the “well” of the “W” and sees the higher index of the cladding outside the well. Other approaches include providing a metal film on one side or on opposing sides of the optical fiber (to selectively attenuate one polarization) or providing a metal cladding over the fiber. Typically, a polarizing fiber includes a window of wavelengths, such as, for example a window of 20 nm or 100 nm, wherein one polarization has high loss and the other polarization has lower, and hopefully, acceptable, loss for the application in which the polarizing fiber is to be used.

Various approaches are described in the following publications and patents that are understood to address polarizing fibers: J.R. Simson et al., *Journal of Lightwave Technology*, 1, 370 (1983); K. Okamoto, *Applied Optics* 23, 2638 (1984); Kin Seng Chang, *Journal of Lightwave Technology*, 7, 436 (1989); Michael J. Messerly et al., *Journal of Lightwave Technology*, 9, 817 (1991); Frank F. Ruhl and Danny Wong, *Optics Letters*, Vol. 14, 648 (1989); M.P. Varnham et al., *Electronics Letters*, 19, 246 (1983); M.P. Varnham et al., *Optics Letters* 9, 306 (1984); K. Okamoto, *Applied Optics* 23, 2638 (1984); K. Okamoto, *Journal of Lightwave Technology* 3, 758 (1985); W. Eickhoff, *Optics Letters* 7, 629 (1982); A. W. Snyder and F. Ruhl, *Journal of the Optical Society of America*, 73, 1165 (1983); R. H. Stolen et al., *Electronics Letters*, 24, 524 (1988); K. Tajima et al., *Journal of Lightwave Technology*, 7, 1499 (1982); K.S. Chiang, *Journal of Lightwave Technology*, 7, 436 (1989); W. Eickhoff, *Electronics Letters*, 16, 762 (1980); P. Kornreich et al., *Proceedings of the SPIE* 2749, 11 (1996); T. Hosaka et al., *Optics Letters* 8, 124 (1983); T. Hosaka et al., *Journal of Quantum Electronics*, 18, 1569 (1982); R. A. Bergh et al., *Optics Letters* 5, 479 (1980).

See also the following U.S. Patents: U.S. Patent No. 4,515,436, entitled “Single-Mode Single Polarization Optical Fiber”, filed February 4, 1983 and issued May 7, 1985 to Howard, Pleibel, Simson, and Stolen; and U.S. Patent No. 5,056,888, entitled “Single-Mode, Single-Polarization Optical Fiber”, filed July 17, 1989 and issued October 15, 1991 to Messerly, Onstott and Mikkelsen.

In some embodiments, a fiber according to the invention can be polarizing at a selected wavelength (e.g., the first wavelength). In certain embodiments, a fiber according to the invention can be polarization maintaining at a selected wavelength of operation (e.g., the first wavelength).

5

FIGURE 9 schematically illustrates one possible refractive index profile **650** for the fiber optic article **612**, where the refractive index profile **650** is taken along a selected diameter of the cross section shown in FIGURE 8, such as along the x axis. The refractive index profile **650** comprises a inner section **652**, which can represent the core **620**, sections **654**, which can represent the inner region **670**, sections **656**, which can represent the cladding **624**, sections **657**, which can represent the longitudinally extending regions **690**; sections **658**, which can represent the second cladding **628**, and sections **660**, which can represent the third cladding **640**. The sections **660** can also be raised, as in indicated by reference numerals **660A**, such as when the region **640** comprises an acrylate polymer having an increased index of refraction.

10
15

FIGURE 10 illustrates another embodiment of a fiber optic article according to the present invention. The fiber optic article **712** comprises a core **720**, an inner region **770** disposed about the core **720**, a cladding **724** disposed about the inner region, and a second cladding **728** disposed about the first cladding **724**. The core **720**, inner region **770**, cladding **724** and second cladding **728** can each comprise, respectively, indices of refraction n_{core} , n_{reg} , n_{clad} and n_{clad2} , where n_{reg} is less than n_{core} ; n_{clad} is less than n_{reg} ; and n_{clad2} is less than n_{clad} .

20

The optical fiber **712** can also include longitudinally extending regions **790** for providing birefringence. The longitudinally extending regions can each have a TCE that is different than the TCE of at least part of the region (e.g., the cladding **724**) that surrounds, at least in part, the longitudinally extending regions **790**. The longitudinally extending regions each induce stress in part or all of a selected region(s) of the fiber for helping provide the fiber with a selected birefringence. Note that the inner region **770** includes an outer perimeter **776**, which can be non-circular. As shown in FIGURE 10, the outer perimeter **776** can include inwardly oriented sections or lengths **780** that each face a different one of the longitudinally extending regions **790**. For example the outer perimeter **776** of the inner region **770** can include a concave section that faces a convex length (e.g., a length of a circular perimeter) of the outer perimeter **791** of a longitudinally extending region **790**.

25
30

The inner region **770** can receive one or both of the longitudinally extending regions **790**. With brief reference to FIGURE 6, the fiber optic article **712** can be drawn from a preform **412**, where the rods **486** that are inserted into the holes of the preform **412** are “stress rods” that form the longitudinally extending regions **790** upon drawing the fiber **712** from the preform **412**.

5

The inner region **770** can receive one or both of the longitudinally extending regions **790**, where receive, as used herein, means that a straight line intersecting the outer perimeter **776** of the inner region **770** also intersects the longitudinally extending region **790**. As an example, see FIGURE 6, where the straight line **487**, which intersects the outer perimeter **476**, also intersects the rod **486**, and hence the inner region **470** can be said to receive the rod **486**.

10

FIGURE 11 schematically illustrates a cross section of another embodiment of a fiber optic article according to the present invention.

15

The fiber optic article **812** comprises a core **820**, an inner region **870** disposed about the core **820**, a cladding **824** disposed about the inner region **870**, and a second cladding **828** disposed about the cladding **824**. The inner region **870** can also be a stress inducing region, such as, for example, by being doped with an appropriate concentration of boron and/or phosphorus, or one or both of the foregoing in conjunction with other materials, such as, for example, germanium or aluminum, for providing the fiber optic article **812** with a selected birefringence, as well as having an appropriate index of refraction for providing the core **820** with a selected NA.

20

FIGURE 12 schematically illustrates one example of an index of refraction profile taken across a selected diameter (e.g., along the x axis) of the cross section of the optical fiber **812** of FIGURE 11. The refractive index profile includes a section **852**, corresponding generally to the core **820**; sections **854**, corresponding generally to the inner region **870**, sections **856**, corresponding generally to the cladding **824**, and sections **858**, corresponding generally to the second cladding **828**. The refractive index profile taken along the y axis is similar, except that the width **W** shown in FIGURE 12 is reduced. Typically the width **W** along each of the axes is selected such that the inner region serves as a cladding for the core **820** and the core can support at least one, and preferably multiple modes.

30

FIGURES 10 and 11 illustrate cross sectional areas A_1 , A_2 , A_3 and A_4 , which can be defined as indicated in conjunction with the discussion of FIGURES 1 and 3A.

Several embodiments of the invention are described above. In general, it is understood that features described in conjunction with one embodiment can be included in any other embodiment described herein, excepting of course combinations of features that include mutually exclusive features.

Additional features of a fiber optic article according to the invention, such as the fiber optical articles described in conjunction with the FIGURES herein, are now described below.

V-number can be a useful parameter with respect to an optical fiber. V-number can be described by a simple formula for most fibers:

$$V = (NA \times \text{radius of the core} \times 2\pi) / \text{free space wavelength of light}$$

For a fiber having a core with a step refractive index profile relative to the cladding, a V-number of greater than 2.405 is generally understood in the art to correspond to a fiber core that can support or propagate more than one mode. Generally speaking, the higher the V-number, the higher the number of modes the fiber (e.g., the core of the fiber) can propagate.

A core of a fiber according to the invention can comprise a V-number at a first wavelength of greater than 2.405 and the core can comprise a numerical aperture (NA) of less than 0.12. The V-number can be at least 3, at least 4, at least 5 or at least 6. The NA can be less than 0.06. The V number can be the V number at an operating wavelength of the optical fiber, such as for example, a wavelength wherein an active material included in the fiber provides light for amplification or lasing. A typical operating wavelength is about 1550 nm, such as when the active material includes erbium.

In one practice, the invention includes a length of fiber having a core having a V-number at the wavelength at which the active material (e.g., a rare earth) provides light responsive to being pumped of no less than 3; no less than 3.5; no less than 4.0; no less than 4.5; no less than 5; no less than 7.5; and no less than 10. In some practices of the invention the V-number is no greater than 3; no greater than 3.5; no greater than 4; no greater than 4.5 no greater than 5; no

greater than 7.5; and no greater than 10. The V-number can be from 3 to 5; from 5 to 7; from 7 to 10; from 3 to 10; from 5 to 10; from 7 to 10; and from 3 to 8.

The core of a fiber according to the invention (e.g., a fiber as shown in FIGURES 1-12) can have a diameter (e.g., D_{core} in FIGURE 1) of at least 10 microns; at least 15 microns; at least 25 microns; at least 40 microns; at least 60 microns; at least 80 microns; and at least 90 microns. Other useful ranges for a core diameter include from 10 microns to 100 microns; from 20 microns to 90 microns; from 25 microns to 85 microns; from 30 microns to 80 microns; and from 40 microns to 70 microns.

In various embodiments of the invention, the birefringence of a fiber according to the present invention (birefringence can be the birefringence of the fiber at the first wavelength or, in other practice of the invention can be the birefringence as measured at 633 nm) can be no less than 1×10^{-4} ; no less than 1.5×10^{-4} ; no less than 2×10^{-4} ; no less than 3×10^{-4} ; no less than 4×10^{-4} ; no less than 5×10^{-4} ; or no less than 6×10^{-4} . Alternatively, the birefringence can be no greater than 1×10^{-4} ; no greater than 1.5×10^{-4} ; no greater than 2×10^{-4} ; no greater than 3×10^{-4} ; no greater than 4×10^{-4} ; no greater than; no greater than 5×10^{-4} ; or no greater than 6×10^{-4} . The birefringence can be from 1×10^{-4} to 6×10^{-4} , or from 1×10^{-4} to 3×10^{-4} , or from 3×10^{-4} to 6×10^{-4} , or from 2×10^{-4} to 5×10^{-4} .

Birefringence is related to beat length by the following formula:

$$\text{Beat length} = (\text{free space wavelength})/(\text{birefringence})$$

Where the birefringence refers to the difference in refractive index for orthogonal polarizations of light (e.g., difference between refractive indices for slow axis and fast axis polarizations).

Ranges of useful beat lengths (beat lengths are for 633 nm) are as follows: in one practice of the invention, the beat length is no less than 0.5 mm; no less than 0.75 mm; no less than 1 mm; greater than 1 mm; no less than 1.5 mm; no less than 2 mm; no less than 2.5 mm; no less than 3 mm; and no less than 5 mm. Beat lengths can also be no greater than 0.5 mm; no greater than 1 mm; no greater than 1.5 mm; no greater than 2 mm; no greater than 2.5 mm; no greater than 3 mm; and no greater than 5 mm.

Other ranges include beat lengths from 0.5 mm to 0.9 mm; from 0.5 mm to 1.5 mm; from 0.5 mm to 2 mm; from 0.5 mm to 2.5 mm; from 0.5 mm to 3 mm; and from 0.5 mm to 5 mm. Beat lengths can be from 1 mm to 5 mm, from greater than 1 mm to 5 mm; from 1.5 mm to 5 mm; from 2 mm to 5 mm; from 2.5 mm to 5 mm; and from 3 mm to 5 mm.

5

Certain exemplary refractive index profiles that can be useful in fibers according to the invention are shown above. These refractive index profiles are idealized. Actual refractive index profiles measured on a preform or from an actual optical fiber drawn from the preform can include other features, as is well known in the art, such as rounded edges between sections and the signature "dip" in the index of refraction of the core due to the burnoff of dopants in the core during the collapse stage of the MCVD process (assuming that the MCVD process is used to fabricate the optical fiber preform). Also, each of the sections of the refractive index profile corresponding to a particular region of the fiber indicates that the index of refraction is substantially constant for the region. This need not be true in all practices of the invention. As is well known in the art the index of refraction of a section, such as, for example, a section (e.g., section 252 of FIGURE 4 corresponding to the core 220 of FIGURE 3A) need not be constant. The index of refraction can be varied according to a predetermined function to provide a particular result. For example, it is known in the art to provide a core comprising a graded refractive index profile, where the profile corresponds to a parabola or other suitable function. As used herein, the use of open language (e.g., comprise, have, include, etc.) in conjunction with describing the index of refraction of a region (e.g., a region has an index of refraction n) does not mean that the index of refraction of the region need be constant throughout the region.

Note that, as described herein, a first region (e.g., a cladding) being "disposed about" a second region (e.g., a core), means that the first region surrounds, at least partially, the second region. Often the first region will surround the second region, and will contact the second region.

One of ordinary skill in the art understands that a material or element can be combined with or incorporated into another material, such as host material, according to a chemical formulation that depends on materials in question. For example, when the host material is silica glass, most of the germanium is understood to be typically incorporated as GeO_2 . Similarly, it is understood that boron is typically incorporated as B_2O_3 . However, the invention is not limited to glass hosts or silica glass hosts, and can be practiced with other types of materials as host,

such as plastics or other types of glasses, such as chalcogenide glasses or fluoride or phosphate glasses, wherein germanium or other elements are incorporated into different compounds than those specifically noted above. Stating that a fiber includes a material, such as boron, for example, means that the material is included in some form in the fiber, where it is understood
5 that the form can be different for different fiber optic articles.

Those skilled in the art will recognize or be able to ascertain using no more than routine experimentation many equivalents to the specific embodiments of the invention described herein. It is therefore to be understood that the foregoing embodiments are presented by way of
10 example only and that within the scope of the appended claims and equivalents thereto, the invention may be practiced otherwise than as specifically described. The present invention is directed to each individual feature, system, material and/or method described herein. In addition, any combination of two or more such features, systems, materials and/or methods, if such features, systems, materials and/or methods are not mutually inconsistent, is included
15 within the scope of the present invention. For example, a fiber optic article having a core comprising fluorine can also an inner region as described above.

In the claims as well as in the specification above all transitional phrases such as “comprising”, “including”, “carrying”, “having”, “containing”, “involving” and the like are
20 understood to be open-ended. Only the transitional phrases “consisting of” and “consisting essentially of” shall be closed or semi-closed transitional phrases, respectively, as set forth in the U.S. Patent Office Manual of Patent Examining Procedure §2111.03, 7th Edition, Revision.

25

30

We claim:

1. An optical fiber, comprising:
 - a core comprising a concentration of at least one rare earth for providing light having a
 - 5 first wavelength responsive to said fiber being pumped by light having a second wavelength that is different than said first wavelength;
 - an inner region disposed about said core;
 - a pump cladding disposed about said inner region, said pump cladding for receiving light
 - having the second wavelength for pumping said fiber;
 - 10 a second cladding disposed about said pump cladding;
 - wherein the index of refraction of the second cladding is less than that of the pump cladding, the index of refraction of the pump cladding is less than that of the inner region, and the index of refraction of the inner region is less than that of the core; and
 - wherein said core comprises a V-number at said first wavelength of greater than 2.405
 - 15 and wherein said core comprises a numerical aperture of less than 0.12.
2. The optical fiber of claim 1 wherein said V-number is at least 3.
3. The optical fiber of claim 1 wherein said numerical aperture is no greater than 0.1.
- 20 4. The optical fiber of claim 1 wherein said inner region comprises material having a first index of refraction and wherein said fiber supports at said first wavelength at least two modes, each of said modes having an effective index that is greater than said first index of refraction.
- 25 5. The optical fiber of claim 1 wherein said concentration of at least one rare earth comprises a concentration of ytterbium and a concentration of erbium.
6. The optical fiber of claim 5 wherein said concentration of erbium includes a concentration of erbium ions and said concentration of ytterbium includes a concentration of
- 30 ytterbium ions that is at least two times greater than said concentration of erbium ions.
7. The optical fiber of claim 6 wherein said core comprises a concentration of fluorine.
8. The optical fiber of claim 7 wherein said core comprises a concentration of phosphorus.

9. The optical fiber of claim 1 wherein said second cladding comprises silica glass and at least one index reducing material.
- 5 10. The optical fiber of claim 1 wherein said pump cladding consists essentially of silica.
11. The optical fiber of claim 1 wherein said concentration of at least one rare earth comprises a concentration of ytterbium.
- 10 12. The optical fiber of claim 1 wherein said concentration of at least one rare earth comprises a concentration of erbium.
13. The optical fiber of claim 1 wherein said concentration of at least one rare earth comprises a concentration of thulium.
- 15 14. The optical fiber of claim 1 wherein said fiber does not include an attenuating material for attenuating certain modes relative to other modes.
15. The optical fiber of claim 1 wherein said fiber comprises a longitudinal axis and at least
20 one longitudinally extending region for providing birefringence.
16. An optical fiber, comprising:
a core comprising a concentration of erbium, a concentration of fluorine and a
concentration of ytterbium for sensitizing said erbium by absorbing pump light having a first
25 wavelength and transferring energy to said erbium, said erbium providing light having a second
wavelength different than the wavelength of the pump light, and
a cladding disposed about said core, said cladding having an index of refraction that is
less than an index of refraction of said core.
- 30 17. The optical fiber of claim 16 wherein said core comprises a concentration of phosphorus.
18. The optical fiber of claim 16 comprising a second cladding disposed about said cladding,
said second cladding having an index of refraction that is less than the index of refraction of said
cladding.

19. The optical fiber of claim 16 wherein said core comprises a numerical aperture of no greater than 0.10.
- 5 20. The optical fiber of claim 16 wherein said core comprises a numerical aperture of no greater than 0.06.
21. The optical fiber of claim 16 wherein said core has a V-number of greater than 2.405 at said second wavelength.
- 10 22. The optical fiber of claim 16 wherein said core has a V-number of at least 3 at said second wavelength.
23. The optical fiber of claim 16 wherein said core has a V-number of greater than 2.405 at
15 said second wavelength and a numerical aperture of no greater than 0.1.
24. The optical fiber of claim 16 wherein said concentration of fluorine is at least 1% by weight.
- 20 25. The optical fiber of claim 16 wherein said concentration of fluorine is at least 3% by weight.
26. An optical fiber, comprising:
a core;
25 an inner region surrounding said core, said inner region having inner and outer perimeters spaced by a thickness T_1 therebetween, a first cross sectional area being defined as all the area within said outer perimeter of said inner region;
a pump cladding for receiving pump light, said pump cladding surrounding said inner region, said pump cladding having inner and outer perimeters spaced by a thickness T_2
30 therebetween, said outer perimeter of said pump cladding having a geometric center;
said inner region having an index of refraction that is less the index of refraction of said core and said pump cladding having an index of refraction that is less than the index of refraction of said inner region; and

wherein T_2 is greater than T_1 , said outer perimeter of said inner region is non-circular in shape and the geometric center of said pump cladding lies within said first cross sectional area.

27. The optical fiber of claim 26 wherein said outer and inner perimeters of said inner region
5 define a cross sectional area A_1 therebetween and said outer and inner perimeters of said pump cladding define a cross sectional area A_2 therebetween, and wherein A_2 is greater than A_1 .
28. The optical fiber of claim 26 wherein said outer perimeter of said inner region comprises
10 a non-oval shape.
29. The optical fiber of claim 26 wherein said outer perimeter of said inner region comprises
at least one inwardly oriented section.
30. The optical fiber of claim 29 wherein said fiber has a longitudinal axis and comprises a
15 longitudinally extending region for providing birefringence, said longitudinally extending region facing said inwardly oriented section.
31. The optical fiber of claim 29 wherein said fiber has a longitudinal axis and comprises a
20 longitudinally extending region for providing birefringence, said inwardly oriented section receiving said longitudinally extending region.
32. The optical fiber of claim 26 wherein at least the majority of the length of said outer
perimeter of said inner region conforms to a circle having a substantially constant radius.
- 25 33. The optical fiber of claim 26 comprising a rare earth for absorbing the pump light.
34. The optical fiber of claim 26 wherein said core comprises erbium and ytterbium.
35. The optical fiber of claim 26 wherein said fiber has an operating wavelength and wherein
30 said core is multimode at said operating wavelength.
36. The optical fiber of claim 26 wherein the numerical aperture of said core is less than
0.12.

37. The optical fiber of claim 26 wherein the numerical aperture of said core is no greater than 0.1.

38. The optical fiber of claim 37 wherein said fiber has an operating wavelength and wherein said core is a multimode core at said operating wavelength.

39. The optical fiber of claim 26 wherein said fiber has an operating wavelength and wherein said core has a numerical aperture of less than 0.12 and a V-number of greater than 2.405 at said operating wavelength.

10

40. The optical fiber of claim 26 wherein said optical fiber has an operating wavelength at which said fiber supports at least two modes and wherein said inner region comprises material having a first index of refraction, each of said two modes having an effective index of refraction that is greater than said first index of refraction.

15

41. The optical fiber of claim 40 wherein said operating wavelength is greater than 900 nm.

42. The optical fiber of any one of claims 38-41 wherein said optical fiber includes at least one rare earth such that responsive to said fiber being pumped by light having a first wavelength said at least one rare earth can provide light having a second wavelength that is different than said first wavelength, and wherein said operating wavelength comprises said second wavelength.

20

43. The optical fiber of claim 26 wherein said pump cladding consists essentially of silica.

25

44. An optical fiber, comprising:

a core comprising a concentration of erbium and a concentration of ytterbium for sensitizing said erbium by absorbing pump light having a first wavelength and transferring energy to said erbium, said erbium providing light having a second wavelength different than the wavelength of the pump light;

30

a cladding disposed about said core, said cladding having an index of refraction that is less than an index of refraction of said core; and

wherein said core has a numerical aperture that is less than 0.12 and a V-number that is greater than 2.405 at said second wavelength.

- 45. The optical fiber of claim 44 wherein said V-number is greater than 3.

- 46. The optical fiber of claim 44 wherein said numerical aperture is no greater than 0.1.

5

10

15

20

FIG. 1

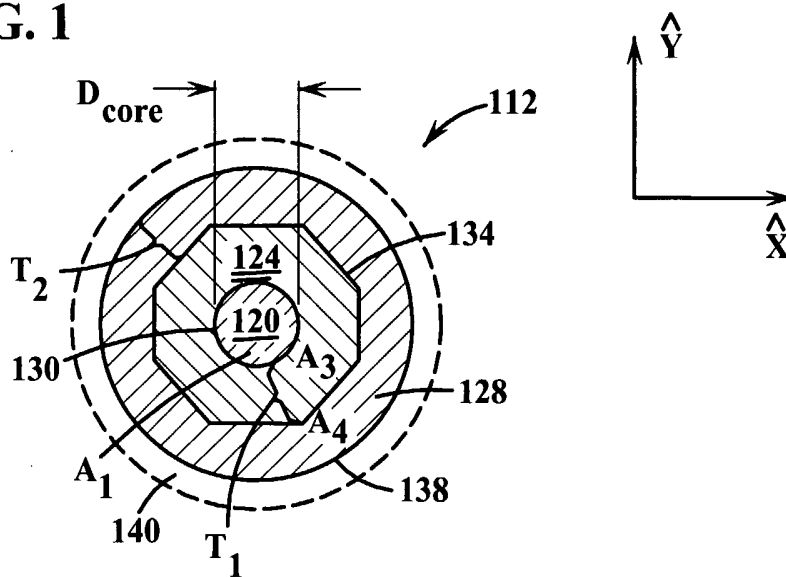

FIG. 2

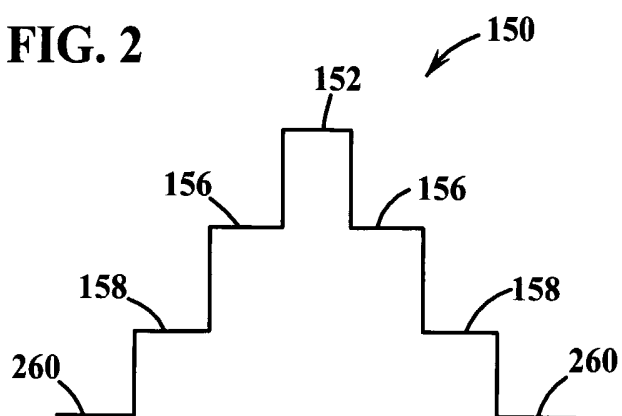

FIG. 3A

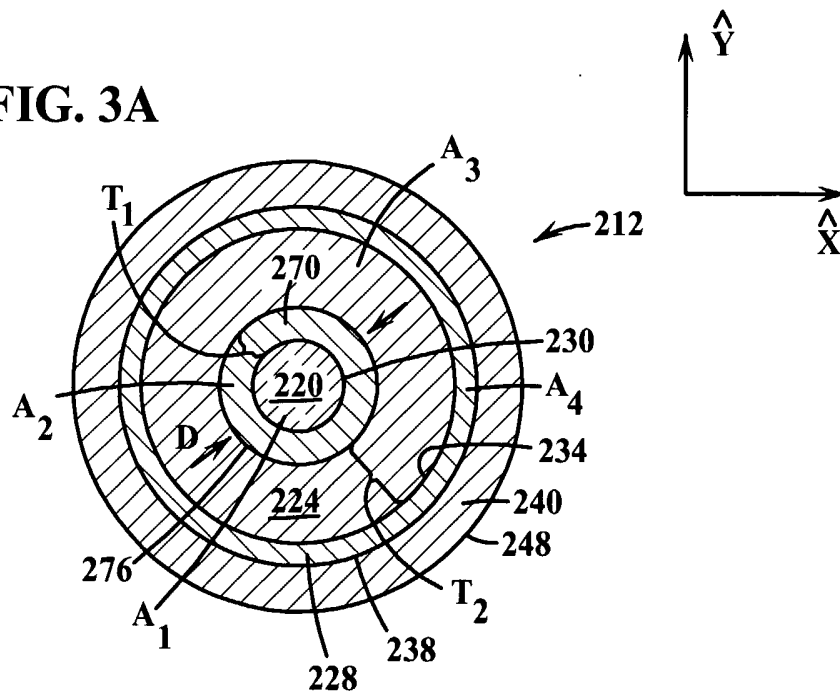

FIG. 4

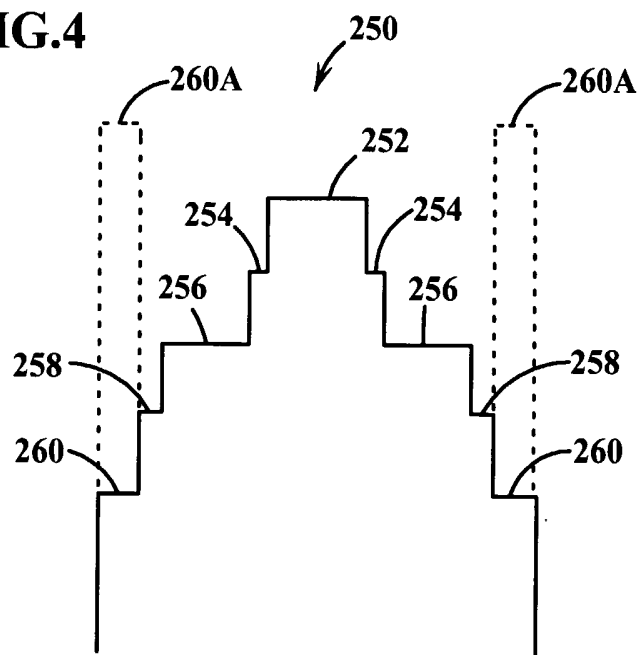
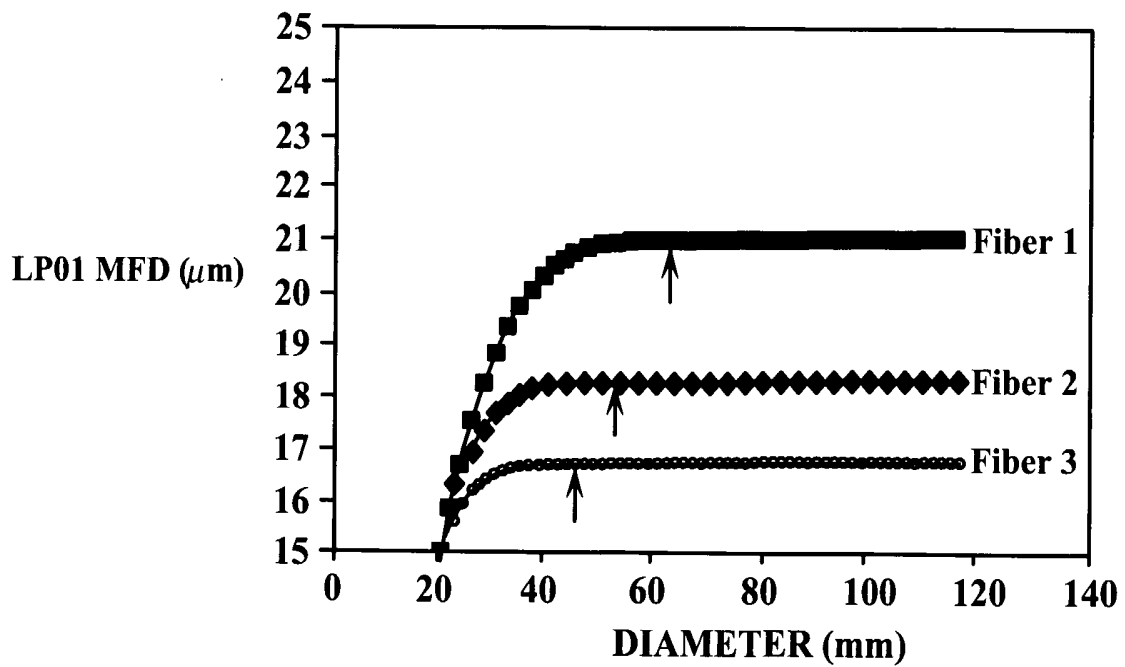

FIG. 3B

Profile	Fiber 1	Fiber 2	Fiber 3
Core Diameter (μm)	20	20	20
Core NA	0.150	0.150	0.150
Effective Core NA	0.061	0.080	0.100
Effective V#	2.490	3.239	4.037
Inner Region NA	0.137	0.127	0.112
Inner Region Diam, (μm)	60	52	44
Clad NA	0.480	0.480	0.480



5/7

FIG. 7

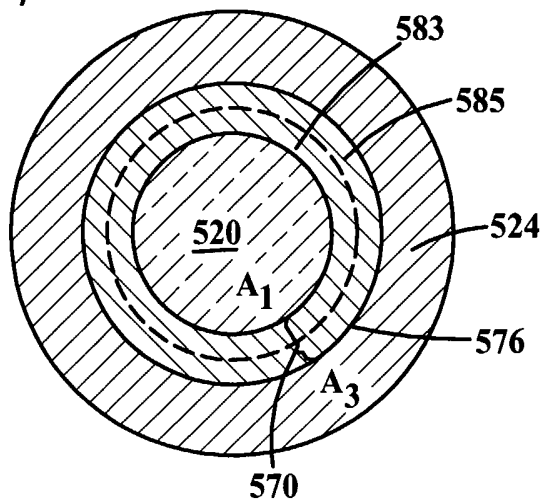
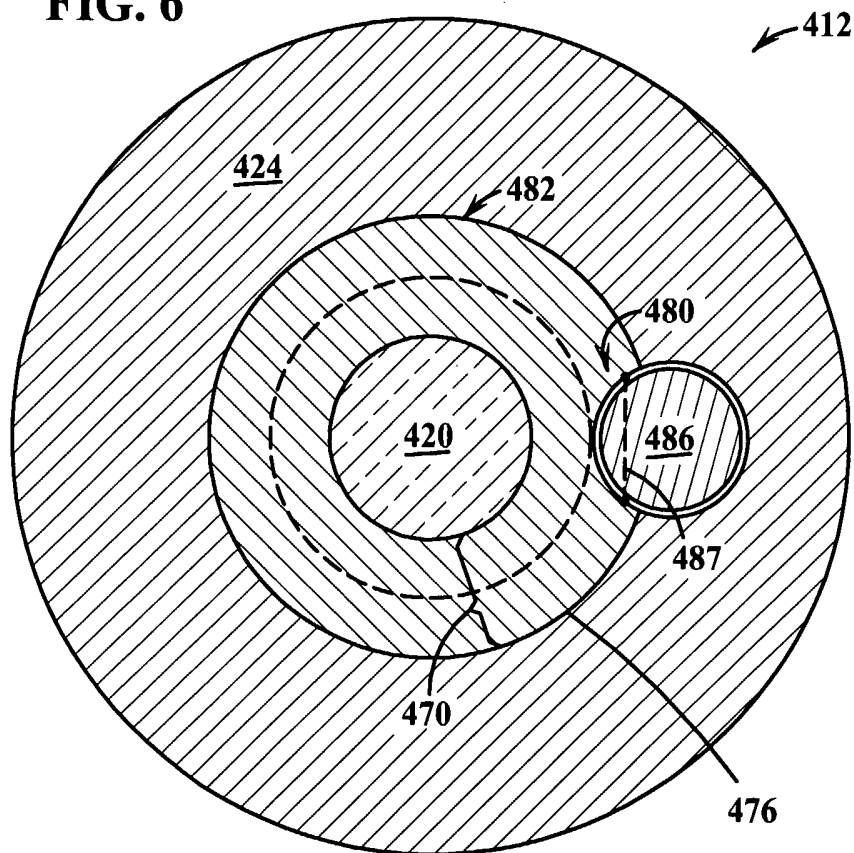
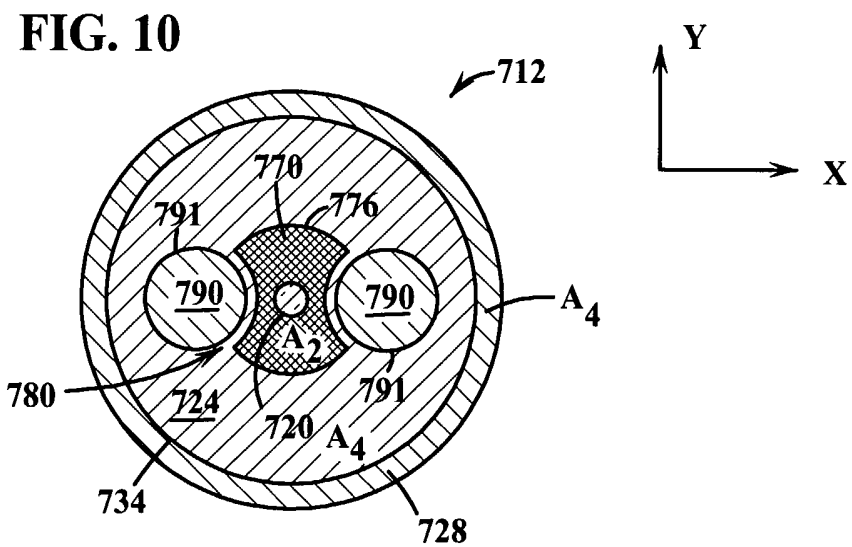
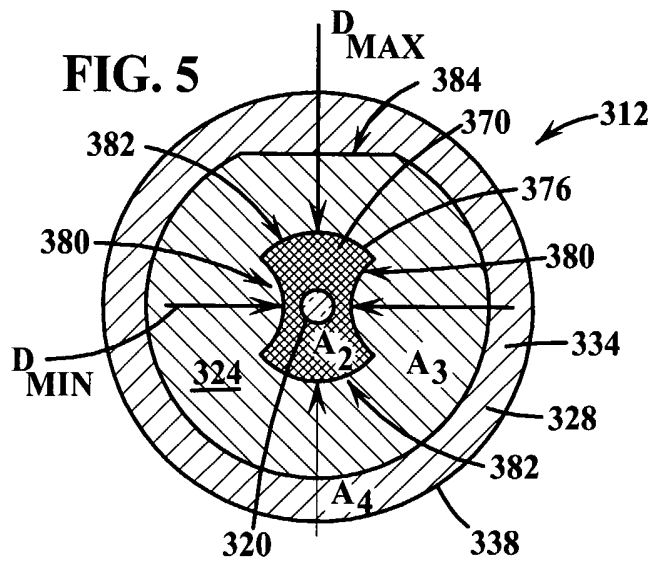

FIG. 6





6/7

FIG. 8

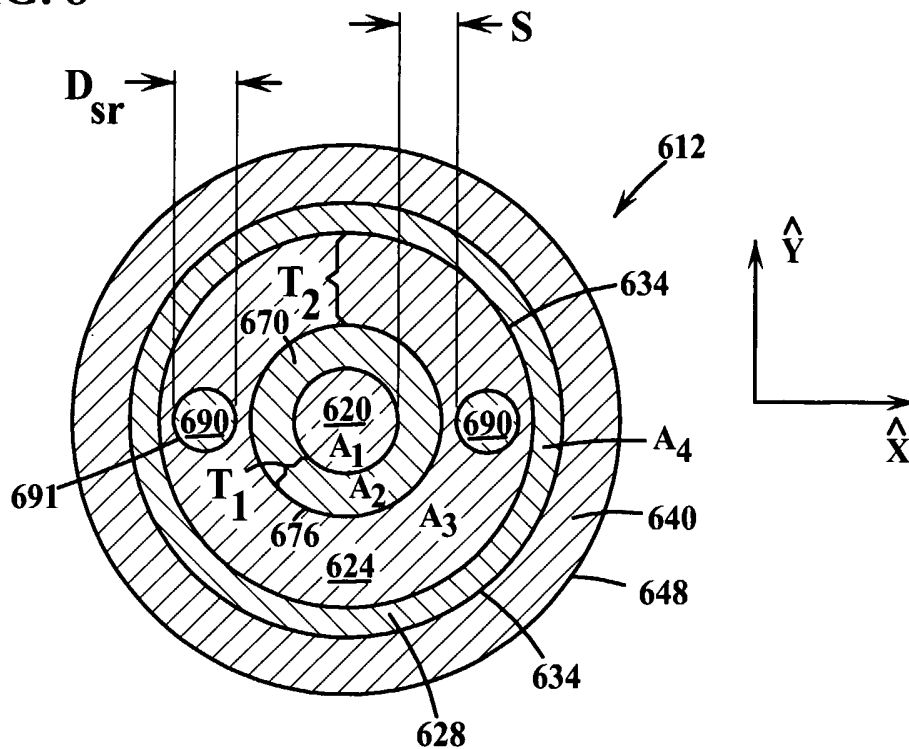

FIG. 9

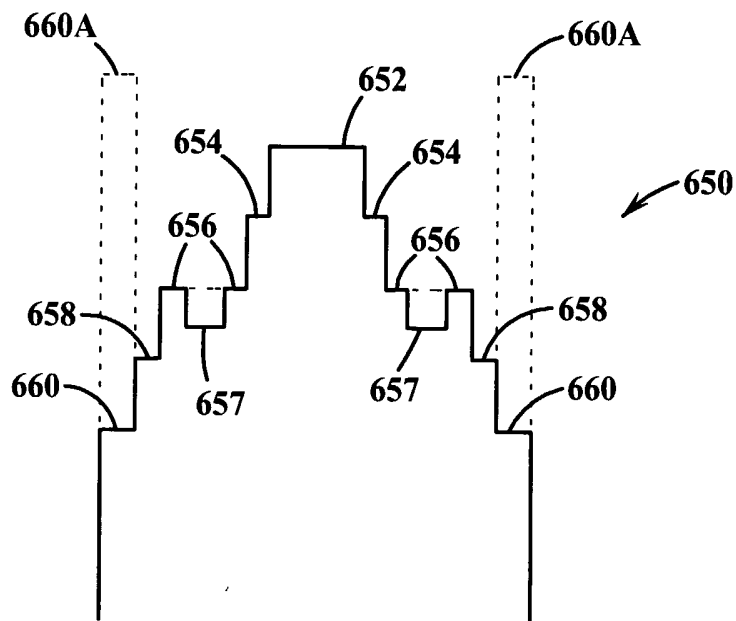

FIG. 11

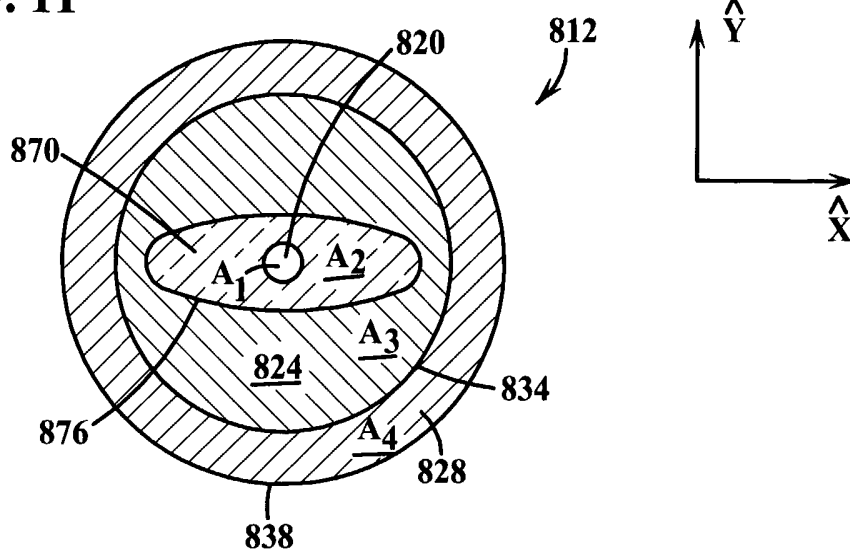

FIG. 12

