

L. E. WEBSTER.
 OFFICE AND DOOR INDICATOR.
 APPLICATION FILED AUG. 29, 1910.

995,746.

Patented June 20, 1911.

2 SHEETS—SHEET 1.

Fig. 1.

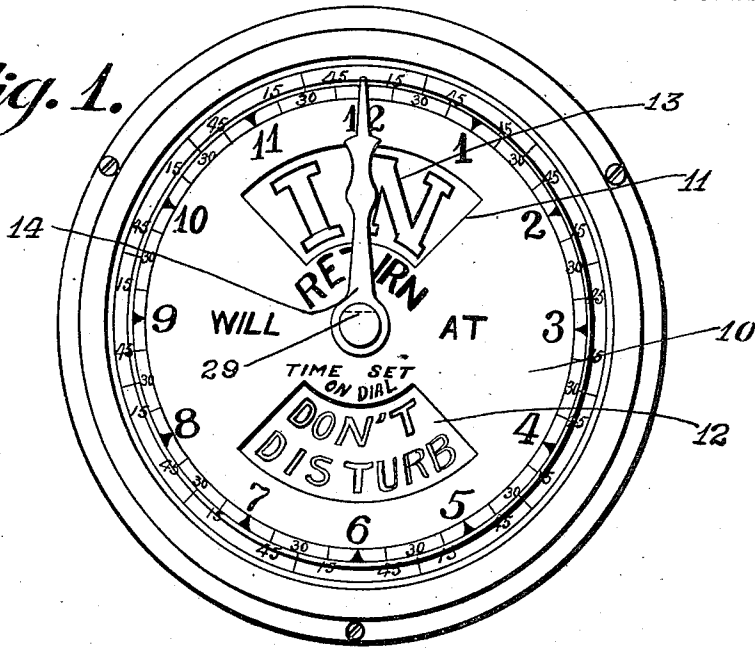

a

Fig. 2.

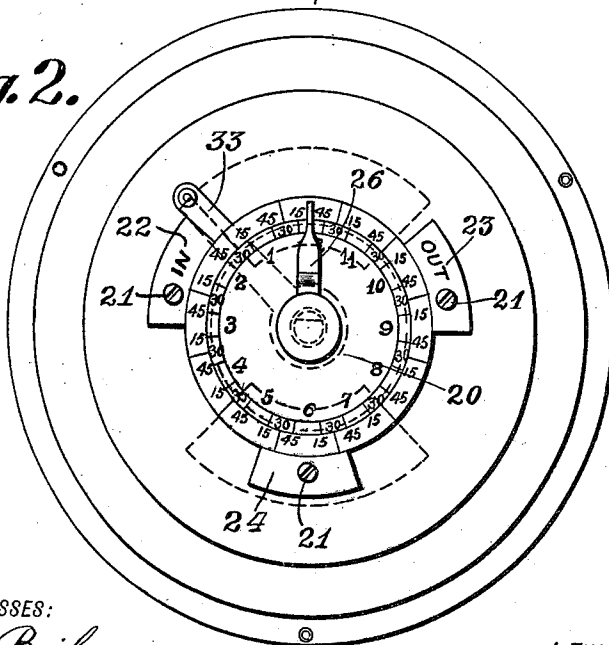

a

WITNESSES:

John Bailey.
Al. F. Maguire

INVENTOR
 LEWIS E. WEBSTER.

BY
Robert Magrane ATTORNEY

L. E. WEBSTER.
 OFFICE AND DOOR INDICATOR.
 APPLICATION FILED AUG. 29, 1910.

995,746.

Patented June 20, 1911.

2 SHEETS—SHEET 2.

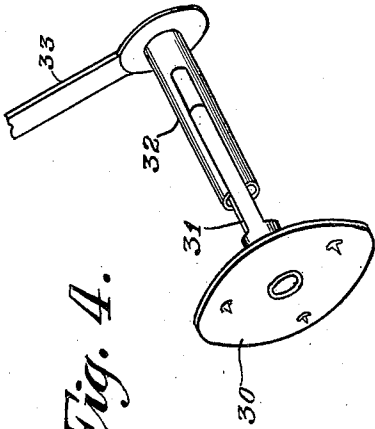

Fig. 4.

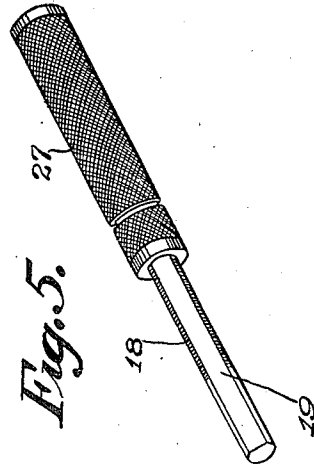

Fig. 5.

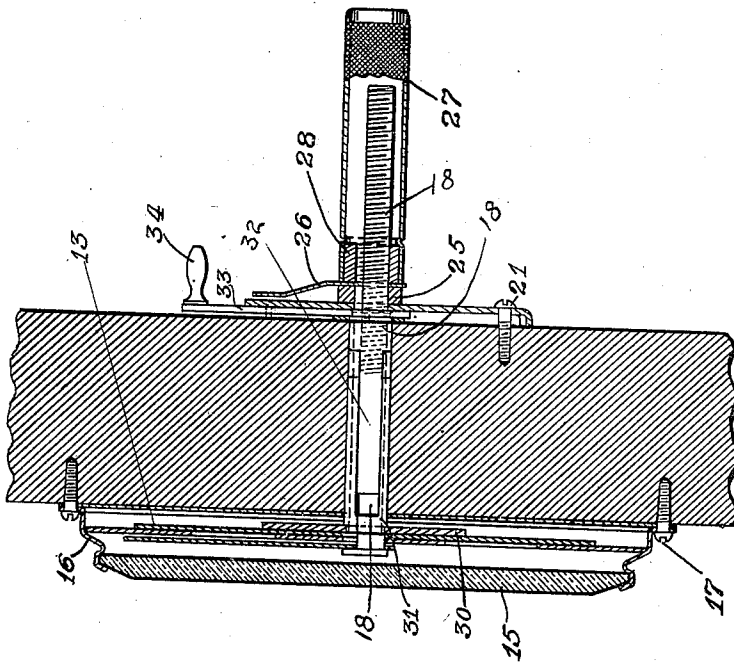

Fig. 3.

WITNESSES:

John Bailey.
Al. F. Maguire

INVENTOR
 LEWIS E. WEBSTER.

BY
Robert Magrane ATTORNEY

UNITED STATES PATENT OFFICE.

LEWIS E. WEBSTER, OF WILKES-BARRE, PENNSYLVANIA.

OFFICE AND DOOR INDICATOR.

995,746.

Specification of Letters Patent. Patented June 20, 1911.

Application filed August 29, 1910. Serial No. 579,422.

To all whom it may concern:

Be it known that I, LEWIS E. WEBSTER, a citizen of the United States, residing at Wilkes-Barre, in the county of Luzerne and State of Pennsylvania, have invented a new and useful Improvement in Office and Door Indicators, of which the following is a specification.

This invention relates to an improved device whereby the occupant of a room or office may indicate his presence or absence, and in the latter case the time of his return, for the information of any one interested. Its principal object is to secure these desired results by the use of mechanism at once simple in construction, certain in its operation, and also adapted for attachment with a minimum of labor.

The invention consists in certain novel features of construction and combinations of parts the essential elements of which are set forth in the appended claims and in the preferred form of embodiment disclosed in the accompanying drawings and description.

Referring to the drawings, Figure 1 is a front elevation of the indicator as it appears in position on the outside of a room or office door; Fig. 2 is a front elevation of the rear or setting part of the indicator as it appears attached to the inside of the door; Fig. 3 is a sectional view taken on the line *a-a* of Fig. 2; and Figs. 4 and 5 are perspective views of details of the mechanism.

As shown in Fig. 1, the stationary dial 10 is provided with clock divisions, and is pierced at 11 and 12 by two segmental openings through which the reading on an inner and movable dial 13 may be seen. In the position of dial 13 as shown in Fig. 1, the words "In" and "Don't disturb" are visible. A pointer 14 is movably mounted in the center of the dial 10 and is adapted to be set in any given position on the dial, as for example, to indicate at what time the occupant of the room will return. All adjustments or manipulation of either indicator must be made from the inner side of the door as will presently appear. To this effect, as shown in Fig. 3, the parts thus far described are protected by a plate glass crystal 15 which is mounted in a spun rim 16 secured to the outer surface of the door by screws 17, and any interference with the indicator from without the door is thus prevented.

The dial 10 is secured to the spun rim 16 as shown in Fig. 3, in a suitable manner. The pointer 14 is attached to the end of a spindle 18 which passes through the door. The spindle is threaded for the greater part of its length, and is also flattened for a part of its circumference as shown at 19 in Fig. 5.

As shown in Fig. 2, a stationary dial 20 is provided for the inside of the door and is mounted concentric with dial 10 by screws 21 passing through off-set lugs 22, 23, 24 into the frame of the door. The spindle 18 passes through dial 20 and at its inner end carries a check-nut 25, a pointer 26, a hollow member 27 equipped with a solid threaded portion 28 adapted to engage the spindle 18. It will be noticed that this construction permits the parts 25, 26 and 27 to be moved to any position along the threaded part of the spindle and secured at such point. Both the pointers 14 and 26 are pierced by a circular hole subtended by a chord equal in size to the flat upon the spindle, as at 29, Fig. 1, so that the pointers can be mounted on the spindle only in the same angular relation. The pointer 14 is secured by a rivet to the spindle, while the inside one is clamped between parts 25 and 28 described above. The inside stationary dial 20 is provided with clock divisions so disposed that the indications by the pointers on the inside and outside dials will be the same.

The movable dial 13 bearing the words "In" "Out" and other suitable inscriptions is mounted on a flange 30, best shown in Fig. 4. This flange is carried by one part of a revoluble sleeve coupling which surrounds the spindle 18 and is independently movable thereof. This sleeve is divided longitudinally into quarter sections which are adapted to slide or telescope within each other, as shown in Fig. 4. This arrangement permits the length of the sleeve coupling to be increased or diminished without interfering with its turning movement about the spindle 18. At the inside end of the sleeve is attached a small crank 33 bearing a handle 34. The crank 33 projects beyond the dial 20 in the clearance space provided by the off-set lugs thereon, and is freely movable between the lugs 22 and 23, to the positions marked "In" and "Out" respectively. Movement of this crank moves the dial 13 to a corre-

sponding position on the outside of the door because of the sleeve coupling.

It will be noticed that the only parts of the device passing through the door are the spindle 18 and the sliding or telescopic sleeves 31 and 32. As the parts 25, 26 and 27 may be adjusted and fixed at any position along the spindle desired, and as the longitudinal adjustment of the sleeve coupling takes care of itself, it will be seen that with this device, the thickness of the door to which it is to be applied is wholly immaterial, and the one device is universal in its application.

In attaching the indicator to a door, a single hole is bored, the two stationary dials are fastened on each side of the door alined with the hole, the sleeves automatically accommodate themselves to the thickness of the door, and the knurled thumb-piece 27 is adjusted for the same dimension.

I am aware that it is not new to combine a plurality of concentric signal devices on the outside of a door; or to combine a single dial and pointer on the outside of a door with a similar arrangement on the inside, so as to prevent unauthorized manipulation; but so far as I am aware, I am the first to combine a plurality of concentric signal devices which are operable only from the inside of the door, and the first to provide means whereby the device may be readily at-

tached to any door regardless of its thickness.

What I claim is:

1. A rotary signal device adapted to be mounted on the outer side of a door, a threaded spindle fastened thereto and passing through the door, a thumb-piece formed of a nut engaging the threaded spindle and a sleeve covering the thread exposed on the inner extremity of the spindle, a pointer carried by the spindle, and means to fasten the thumb-piece and the pointer in any desired position along the threaded portion of the spindle, substantially as described.

2. A rotary signal device adapted to be mounted on one side of a door, a crank adapted to move said signal device from the other side of the door, the said device and crank being connected by sleeves having tongue and slot joints, a second rotary signal device concentric with the axis of the first, a thumb-piece adapted to move said second device from the other side of the door, a spindle connecting the said second signal device and said thumb-piece, and provided with means whereby the thumb-piece may be affixed to said spindle at any desired point along its length.

LEWIS E. WEBSTER.

Witnesses:

ROBERT MAGRANE,
CORNELIUS J. SHEA.