

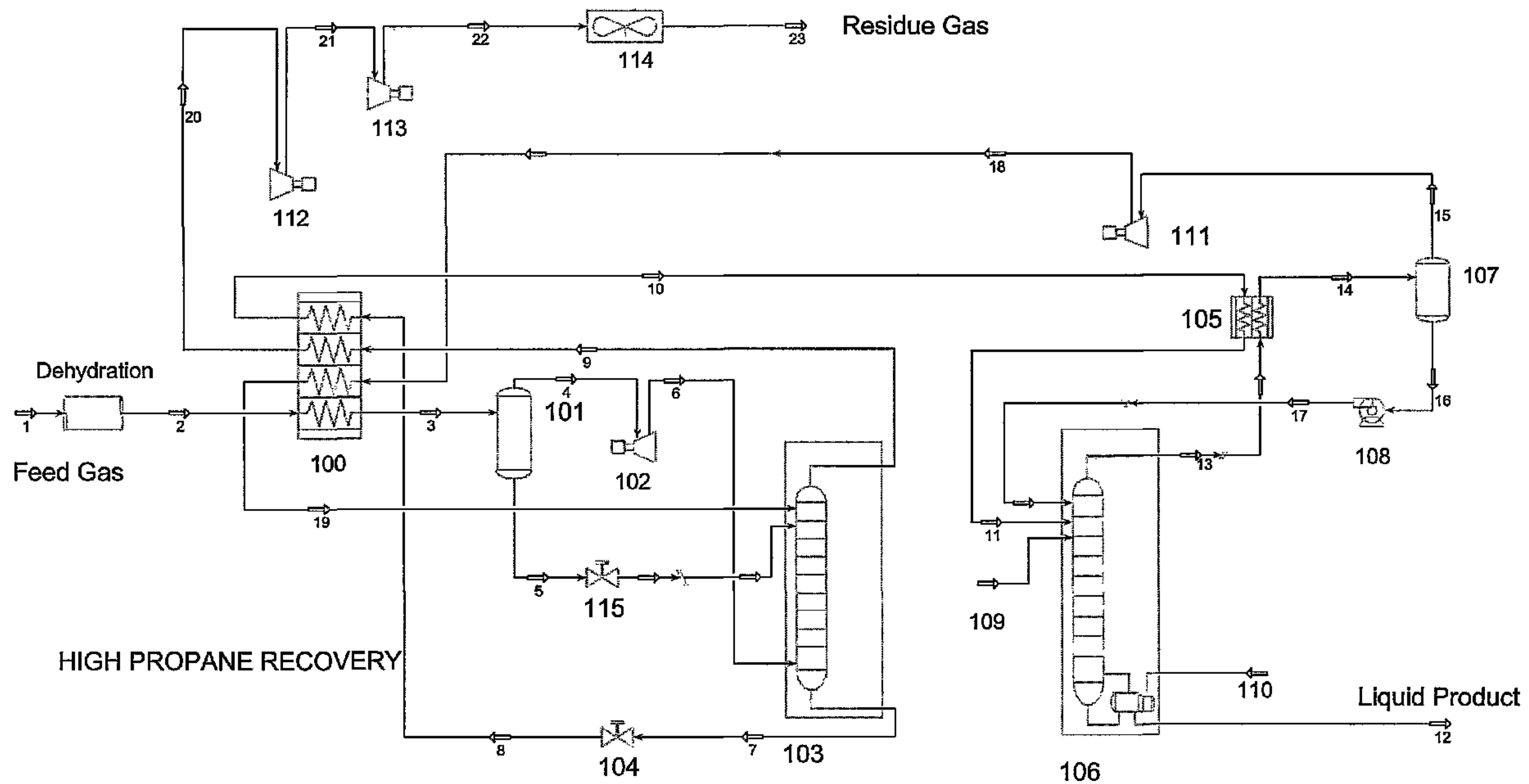

(86) Date de dépôt PCT/PCT Filing Date: 2001/06/27
 (87) Date publication PCT/PCT Publication Date: 2002/02/21
 (45) Date de délivrance/Issue Date: 2007/03/13
 (85) Entrée phase nationale/National Entry: 2002/11/22
 (86) N° demande PCT/PCT Application No.: US 2001/020633
 (87) N° publication PCT/PCT Publication No.: 2002/014763
 (30) Priorité/Priority: 2000/08/11 (US60/224,958)

(51) Cl.Int./Int.Cl. *F25J 3/02* (2006.01)
 (72) Inventeur/Inventor:
 MAK, JOHN, US
 (73) Propriétaire/Owner:
 FLUOR CORPORATION, US
 (74) Agent: SMART & BIGGAR

(54) Titre : PROCESSUS DE RECUPERATION DE PROPANE DE HAUTE TENEUR ET AGENCEMENTS
 (54) Title: HIGH PROPANE RECOVERY PROCESS AND CONFIGURATIONS



(57) Abrégé/Abstract:

A gas processing plant has a de-ethanizer (106) and a refluxed absorber (103), wherein the absorber (103) operates at higher pressure than the de-ethanizer (106), and wherein at least a portion of the absorber bottoms product (7) is expanded to provide cooling for the absorber reflux stream and/or the distillation column feed stream. Especially contemplated gas processing plants include propane and ethane recovery plants, and where the gas processing plant is an ethane recovery plant, it is contemplated that the ethane product comprises no more than 500ppm carbon dioxide.

(12) INTERNATIONAL APPLICATION PUBLISHED UNDER THE PATENT COOPERATION TREATY (PCT)

(19) World Intellectual Property Organization
International Bureau(43) International Publication Date
21 February 2002 (21.02.2002)

PCT

(10) International Publication Number
WO 02/14763 A1

- (51) International Patent Classification⁷: F25J 3/00
- (21) International Application Number: PCT/US01/20633
- (22) International Filing Date: 27 June 2001 (27.06.2001)
- (25) Filing Language: English
- (26) Publication Language: English
- (30) Priority Data:
60/224,958 11 August 2000 (11.08.2000) US
- (71) Applicant (for all designated States except US): **FLUOR CORPORATION** [US/US]; One Enterprise Drive, Aliso Viejo, CA 92656-2606 (US).
- (72) Inventor; and
(75) Inventor/Applicant (for US only): **MAK, John** [US/US]; Fluor Corporation, One Enterprise Drive, Aliso Viejo, CA 92656-2606 (US).
- (74) Agent: **FISH, Robert, D.**; Fish & Associates, LLP, 1440 N. Harbor Blvd., Suite 706, Fullerton, CA 92835 (US).
- (81) Designated States (*national*): AE, AG, AL, AM, AT, AT (utility model), AU, AZ, BA, BB, BG, BR, BY, BZ, CA, CH, CN, CO, CR, CU, CZ, CZ (utility model), DE, DE (utility model), DK, DK (utility model), DM, DZ, EC, EE, EE (utility model), ES, FI, FI (utility model), GB, GD, GE, GH, GM, HR, HU, ID, IL, IN, IS, JP, KE, KG, KP, KR, KZ, LC, LK, LR, LS, LT, LU, LV, MA, MD, MG, MK, MN, MW, MX, MZ, NO, NZ, PL, PT, RO, RU, SD, SE, SG, SI, SK, SK (utility model), SL, TJ, TM, TR, TT, TZ, UA, UG, US, UZ, VN, YU, ZA, ZW.
- (84) Designated States (*regional*): ARIPO patent (GH, GM, KE, LS, MW, MZ, SD, SL, SZ, TZ, UG, ZW), Eurasian patent (AM, AZ, BY, KG, KZ, MD, RU, TJ, TM), European patent (AT, BE, CH, CY, DE, DK, ES, FI, FR, GB, GR, IE, IT, LU, MC, NL, PT, SE, TR), OAPI patent (BF, BJ, CF, CG, CI, CM, GA, GN, GW, ML, MR, NE, SN, TD, TG).
- Published:**
— with international search report
— with amended claims
- For two-letter codes and other abbreviations, refer to the "Guidance Notes on Codes and Abbreviations" appearing at the beginning of each regular issue of the PCT Gazette.*

(54) Title: HIGH PROPANE RECOVERY PROCESS AND CONFIGURATIONS

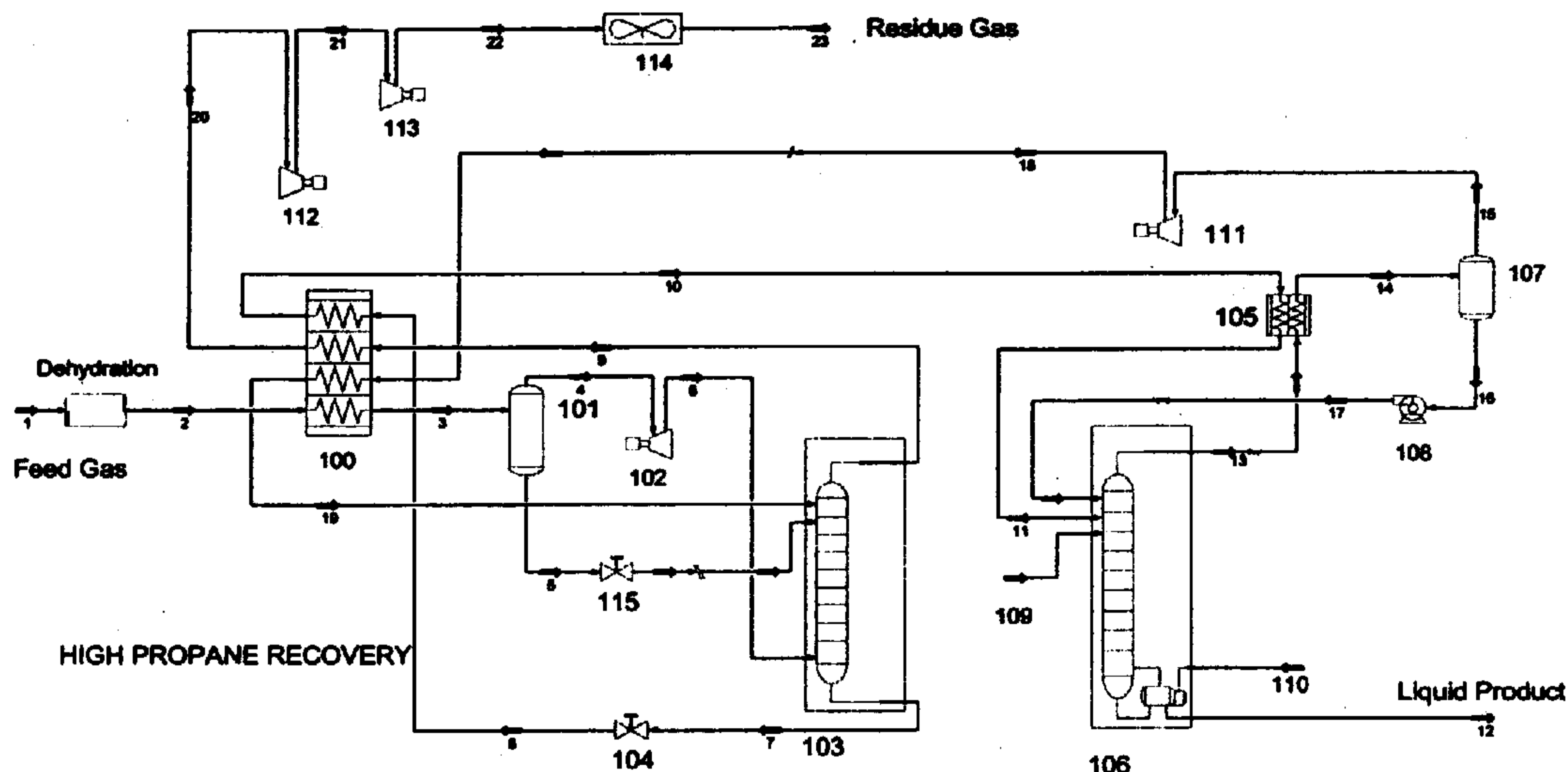

(57) Abstract: A gas processing plant has a de-ethanizer (106) and a refluxed absorber (103), wherein the absorber (103) operates at higher pressure than the de-ethanizer (106), and wherein at least a portion of the absorber bottoms product (7) is expanded to provide cooling for the absorber reflux stream and/or the distillation column feed stream. Especially contemplated gas processing plants include propane and ethane recovery plants, and where the gas processing plant is an ethane recovery plant, it is contemplated that the ethane product comprises no more than 500ppm carbon dioxide.

WO 02/14763 A1

HIGH PROPANE RECOVERY PROCESS AND CONFIGURATIONS

Field of The Invention

The field of the invention is recovery of a gas fraction from a feed gas, and particularly
5 relates to propane recovery.

Background of The Invention

Many natural and man-made gases comprise a variety of different hydrocarbons, and numerous methods and configurations are known in the art to produce commercially relevant fractions from such gases. Among other processes, cryogenic gas separation (see *e.g.*, U.S. Pat.
10 Nos. 4,157,904 to *Campbell et al.*, 4,690,702 to *Paradowski et al.*, or 5,275,005 to *Campbell et al.*) has become a preferred method of gas separation.

In a typical gas separation process, a feed gas stream under pressure is cooled by heat exchanger and as the gas cools, liquids condense from the cooled gas. The liquids are then expanded and fractionated in a distillation column (*e.g.*, de-ethanizer or de-methanizer) to
15 separate residual components such as methane, nitrogen and other volatile gases as overhead vapor from the desired C₂, C₃ and heavier components. In some configurations, uncondensed cooled feed gas is expanded to condense additional liquid, which may subsequently be employed as C₂ and C₃ absorbing agent in an absorber. Various improvements on the basic concept of cryogenic gas separation have been developed.

20 For example, *Rambo et al.* describe in U.S. Pat. No. 5,890,378 a system in which (a) the absorber is refluxed, (b) in which the de-ethanizer condenser provides the reflux for both the absorber and the de-ethanizer while the cooling requirements are met using a turboexpander, and (c) in which the absorber and the de-ethanizer operate at substantially the same pressure. Although *Rambo's* configuration advantageously reduces capital cost for equipment associated
25 with providing reflux for the absorption section and the de-ethanizer, propane recovery significantly decreases as the operating pressure in the absorber rises, especially at a pressure above 500psig, where separation of ethane from propane in the de-ethanizer becomes increasingly difficult. Consequently, *Rambo's* system is generally limited by the upper operating limit of the de-ethanizer pressure. Increasing of the absorber pressure while maintaining
30 desirable propane recovery becomes difficult, if not impossible in *Rambo's* process configuration. Moreover, operating the absorber and de-ethanizer at a pressure at or below

500psig typically necessitates higher residue gas recompression, thereby incurring relatively high operating cost.

To circumvent at least some of the problems associated with relatively high cost associated with residue gas recompression, *Sorensen* describes in U.S. Pat. No. 5,953,935 a plant configuration in which an additional fractionation column is included. The absorber reflux in *Sorensen's* plant configuration is produced by compressing, cooling, and Joule Thomson expansion of a slipstream of feed gas. Although *Sorensen's* configuration generally provides an improved propane recovery with substantially no increase in plant residue compression horsepower, propane recovery significantly decreases as the operating pressure in the absorber rises, especially at a pressure above about 500psig. Furthermore, ethane recovery using such known systems designed for propane recovery is normally limited to about 20% recovery.

In order to improve ethane recovery with a low CO₂ content in the ethane product, *Campbell* describes in U.S. Pat. No. 6,182,469 a tower reboiling scheme in which one or more tower liquid distillation streams from a point higher in the absorber are employed for stripping of undesirable components (*e.g.*, carbon dioxide in a demethanizer). *Campbell's* scheme typically requires over-stripping of the ethane product, and CO₂ removal is generally limited to about 6%. Moreover, additional CO₂ removal using *Campbell's* process will significantly reduce ethane recovery, and increase power consumption. Furthermore, and especially where the ethane product is used for chemical production, the product in *Campbell's* configuration typically requires further treatment to remove CO₂ to or below a level of 500ppmv, which often requires substantial capital and operating expenditure.

Although there are various configurations and processes for improved propane and ethane recovery known in the art, all or almost all of them, suffer from one or more disadvantage. Therefore, there is still a need to provide improved methods and compositions for high propane recovery processes and configurations.

Summary of the Invention

The present invention is directed to methods and configurations of a gas plant comprising a refluxed absorber producing a bottoms product stream and receiving a feedstock and an absorber reflux stream. A distillation column is fluidly coupled to the absorber, receives a

distillation column feed stream and operates at a pressure that is at least 100psi lower than the operating pressure of the absorber.

In one aspect of the inventive subject matter, the distillation column comprises a de-ethanizer column, the feedstock has a pressure of between 1000psig and 2000psig, and is expanded in a turbine expander. The bottoms product of the absorber is expanded in a range of 100-250psi, thereby cooling the product to a temperature between -95°F to -125°F. It is also contemplated that the cooled and expanded bottoms product stream is then fed as the distillation column feed stream into the distillation column, and it is still further contemplated that the expanded bottoms product stream may further provide cooling for a distillation column reflux stream. In a particularly contemplated aspect the distillation column produces an overhead stream that is compressed, cooled, and fed into the absorber as the absorber reflux stream.

In another aspect of the inventive subject matter, the distillation column comprises a de-ethanizer column, the feedstock has a pressure of between 550psig and 800psig, and is not expanded in a turbine expander. The bottoms product of the absorber is expanded in a range of 100-250psi, thereby cooling the product to a temperature between -50°F to -70°F. It is also contemplated that the cooled and expanded bottoms product stream is then fed as the distillation column feed stream into the distillation column, and that at least a portion of the feedstock is fed into a lower section of the distillation column. In a further contemplated aspect, an external refrigeration is coupled to the distillation column and feed exchanger.

In a still further aspect of the inventive subject matter, the distillation column comprises a demethanizer, the feedstock is at a pressure of between 1000psig and 2000psig, and is expanded in a turboexpander. It is also contemplated that in such configurations the absorber bottoms product is expanded in a range of 100-250psi, thereby cooling the bottoms product stream to a temperature of between -95°F to -125°F. It is further contemplated that the expanded bottoms product is fed as the distillation column feed stream into the distillation column, wherein the distillation column produces a distillation column overhead stream that is compressed, cooled, and fed into the absorber as the absorber reflux stream, and that the distillation column produces a distillation column product stream that comprises no more than 500ppm carbon dioxide. In particularly contemplated aspects, the feedstock is split into a first portion and a second portion, and wherein an external refrigeration cools at least part of the first portion, and wherein at least one side reboiler located in the upper section of the distillation

76186-35

column (*i.e.* is fluidly coupled to the demethanizer between a top tray and a position eight trays below the top tray), provides reboiling of the distillation column, provides heat duty for stripping of CO₂ from the demethanizer product stream, and further provides cooling of the first portion of the feedstock.

In one embodiment, the invention provides a gas processing plant comprising: a refluxed absorber operating at a first pressure, producing a bottoms product stream and receiving a feedstock and an absorber reflux stream; a distillation column fluidly coupled to the absorber, receiving a distillation column feed stream, producing a distillation column overhead stream, and operating at a second pressure that is at least 100 psi lower than the first pressure; and an expansion device coupled to the absorber and configured to expand at least a portion of the bottoms product stream to thereby generate an expanded bottoms product stream and to thereby provide cooling for at least one of the absorber reflux stream and the distillation column feed stream; and wherein the distillation column overhead stream is separated into a liquid portion that provides reflux for the distillation column and a gaseous portion that is liquefied and provides the absorber reflux stream.

Various features, aspects and advantages of the present invention will become more apparent from the following detailed description of preferred embodiments of the invention, along with the accompanying drawings.

Brief Description of The Drawing

Figure 1 is a prior art schematic of an exemplary gas processing plant for propane recovery.

76186-35

Figure 2 is a schematic of an exemplary configuration for gas processing plant for propane recovery with a turboexpander, a feed gas pressure of about 1300 psig, and a de-ethanizer as distillation column.

5 Figure 2A is a graph depicting a heat composite curve for heat exchanger 100 in a plant configuration according to Figure 2.

Figure 3 is a prior art schematic of another exemplary gas processing plant for ethane recovery.

10 Figure 4 is a schematic of a further exemplary configuration for a gas processing plant for ethane recovery with a turboexpander, a feed gas pressure of about 1300 psig, and a demethanizer as distillation column.

15 Figure 4A is a graph depicting a heat composite curve for heat exchanger 100 in a plant configuration according to Figure 4.

Figure 4B is a graph depicting a heat composite curve for a side heat exchanger 116 in a plant configuration according to Figure 4.

20 Figure 5 is a schematic of yet another exemplary configuration for a gas processing plant without turboexpander, a feed gas pressure of about 750 psig, and a de-ethanizer as distillation column.

Figure 6 is a schematic of an exemplary configuration for a gas processing plant in which the refluxed absorber and the distillation column are configured in a single tower.

Detailed Description

The inventors discovered that high propane recovery (*i.e.*, at least 95%) from a feed gas with relatively high (*e.g.*, between about 1000psig to 2000psig) to relatively low (*e.g.*, between about 550psig to 800psig) pressure can be realized by operating an absorber in a gas processing plant at a significantly higher pressure than a distillation column (*e.g.*, a de-ethanizer), and in which the absorber bottoms product is expanded to provide cooling for the absorber reflux stream and/or the distillation column feed. The inventors have further discovered that such configurations may also be employed to significantly increase ethane recovery from feed gas with relatively high pressure, and to significantly remove CO₂.

More particularly, the inventors contemplate a gas processing plant that comprises a refluxed absorber operating at a first pressure, that produces a bottoms product stream and that receives a feedstock and an absorber reflux stream. Contemplated configurations further include a distillation column that is fluidly coupled to the absorber that receives a distillation column feed stream and that is operated at a second pressure, which is at least 100psi lower than the operating pressure of the absorber, wherein at least a portion of the bottoms product stream is expanded and provides cooling for the absorber reflux stream and/or the distillation column feed stream.

Prior art **Figure 1** depicts a known configuration for a propane recovery plant in which a feed gas stream 1 at a pressure of about 1300psig is cooled in a heat exchanger 100, separated into a gaseous and a liquid phase, and the gaseous phase is then expanded in a turboexpander 102 and fed into the absorber 103, which operates at a pressure of about 450psig. The liquid phase (if present) is Joule-Thomson (JT) expanded, and directly fed into a lower portion of the absorber. The bottoms product of the absorber is pumped via pump 104 through heat exchanger 100, and the heated bottoms product is subsequently fed into the de-ethanizer.

The absorber 103 is refluxed using cooled de-ethanizer overhead stream 14, wherein the cooling of the reflux is provided by the overhead vapor from the absorber, which is further heated in heat exchanger 100 prior to recompression in recompressor 112 and subsequent residue gas compressor 113. Absorber 103 further provides reflux stream 17 that is fed into the

de-ethanizer via pump 108. Liquid product stream 12 leaves the de-ethanizer with a propane recovery typically above 95%.

In contrast, a particularly preferred configuration of a gas processing plant for propane recovery as depicted in **Figure 2** has a refluxed absorber 103 that is operated at a pressure of about 590psig and a de-ethanizer 106 that is operated at a pressure of about 410psig, while the feed gas stream 1 has a pressure of about 1300psig. The feed gas stream 1 is cooled in heat exchanger 100 and separated in a separator 101 in a liquid portion 5 and a gaseous portion 4. The liquid portion 5 (if present) is fed into the absorber 103, while the gaseous portion 4 is expanded in a turboexpander 102 to the level of the operating pressure of the absorber. Expanded gaseous portion 6 is then fed into a lower section of the absorber 103. The absorber 103 receives a reflux stream 19, which is provided by the overhead stream 13 of the de-ethanizer 106. The overhead stream 13 is cooled in a heat exchanger 105, and separated in a separator 107 in a gaseous phase 15 and a liquid phase 16. Liquid phase 16 is pumped back to the de-ethanizer as de-ethanizer reflux via pump 108, while gaseous phase 15 is compressed in compressor 111 and cooled in the heat exchanger 100 before entering the absorber as reflux stream 19.

The absorber bottoms stream 7 is expanded in JT valve 104, thereby lowering the pressure in an amount of about 180psi and significantly cooling the absorber bottoms stream. The cooled absorber bottoms stream 8 is then employed as a coolant in the heat exchangers 100 and 105 before entering de-ethanizer 106 as de-ethanizer feed stream 11. Absorber overhead stream 9 is heated in the heat exchanger 100 and recompressed in recompressor 112 (which is operationally coupled to the turboexpander). Recompressed overhead stream 21 is further compressed in residue gas compressor 113 and fed into a residue gas pipeline. The de-ethanizer bottoms stream 12 provides liquid product at a propane recovery of at least 99%.

With respect to the feed gas streams it is contemplated that numerous natural and man-made feed gas streams are suitable for use in conjunction with the teachings presented herein, and especially preferred feed gas streams include natural gases, refinery gases, and synthetic gas streams from hydrocarbon materials such as naphtha, coal, oil, lignite, etc. Consequently, the pressure of contemplated feed gas streams may vary considerably. However, it is generally preferred that appropriate feed gas pressures for plant configurations according to Figure 2 will generally be in the range between 1000psig and 2000psig, and that at least a portion of the

feedstock is expanded in a turboexpander to provide cooling and/or power for the residue gas recompression.

Depending on the pressure of the feed gas and the amount of feed gas expansion in the turboexpander, the operating pressure for the absorber may vary in the range from between
5 500psig to 800psig, more preferably between 500psig and 750psig and most preferably between 550psig and 700psig. Thus, it should be especially appreciated that the bottoms product stream has leave the absorber at a considerable pressure, and that cooling can be provided from expanding the bottoms product stream to a lower pressure. In a particularly contemplated aspect, expansion of the bottoms product stream reduces the bottoms product stream pressure in a range
10 of about 100psi to about 250psi, and more preferably in a range of about 150psi to 200psi. Thus, it is contemplated that the absorber is operated at a pressure that is at least 100psi higher than the pressure of the distillation column, however, alternative pressure differences are also contemplated and include absorber pressure differences of less than 100psi (e.g., between 50psi and 99psi, and even less), and particularly include absorber pressure differences of more than
15 100psi (e.g., between 101psi and 150psi, more preferably between 151psi and 250psi, and even higher).

Consequently, it should be appreciated that the temperature of the expanded bottoms product stream will be in a range of about -95°F to -125°F. Therefore, it is contemplated that the expanded bottoms product stream may further provide cooling for various streams within the gas
20 processing plant, and it is especially contemplated that the expanded bottoms product stream further cools a distillation column overhead stream, and absorber reflux. It is still further contemplated that the expanded bottoms product stream may be fed into the distillation column at various positions, however, it is particularly preferred that the expanded bottoms product stream is fed into the distillation column at a position below the feed point of the reflux (e.g., at
25 least three trays below the upmost tray in the distillation column)

With respect to the distillation column it should be especially appreciated that the distillation column produces a distillation column overhead stream that is compressed, cooled, and fed into the absorber as the absorber reflux stream, thereby providing a particularly lean stream (stream 13 containing 64 mol% methane and 33 mol% ethane) that may be employed to
30 recover the propane and heavier components from the expanded feed gas streams. Thus contemplated configurations according to Figure 2 receive a feedstock that comprises propane,

and provide a distillation column product stream that comprises at least 95% of the propane in the feedstock.

In another particularly preferred aspect of the inventive subject matter, a gas processing plant as depicted in **Figure 5** has a refluxed absorber 103 that is operated at a pressure of about 720psig and a de-ethanizer 106 that is operated at a pressure of about 500psig, while the feed gas stream 1 has a pressure of about 760psig. The feed gas stream 1 is separated in separator 101 in a liquid portion 5 and a gaseous portion 2. The liquid portion is JT expanded in JT valve 115 and directly fed into the de-ethanizer column 106. The gaseous portion 2 is cooled in a heat exchanger 100 and the cooled gaseous portion 6 is then fed into absorber 103 without expansion in a turboexpander. The absorber 103 receives a reflux stream 19, which is provided by the overhead stream 13 from the reflux drum 102 of the de-ethanizer 106. The de-ethanizer overhead stream 13, coupled with an external refrigeration stream 109, and absorber overhead vapor stream 9 are used to cool the feed stream 2 in exchanger 100. The de-ethanizer overhead stream 13 is heated to ambient temperature in exchanger 100 by the feed stream in exchanger 100, and is then compressed in a compressor to stream 18. The compressor discharge stream 18 is cooled in an air cooled exchanger 114 and then further chilled in heat exchanger 105 with absorber bottoms stream 8 before entering the absorber as reflux stream 19.

The absorber bottoms stream 7 is expanded in JT valve 104, thereby lowering the pressure in an amount of about 210psi and significantly cooling the absorber bottoms stream from -47°F to -61°F . The expanded and cooled absorber bottoms stream 8 is then employed as a coolant in the heat exchanger 105 before entering de-ethanizer 106 as de-ethanizer feed stream 11. Absorber overhead stream 9 is heated in the heat exchanger 100 and fed into the residue gas pipeline without recompression. The de-ethanizer bottoms stream 12 provides liquid product at a propane recovery of at least 95%.

With respect to the type and chemical composition of the feed gas the same consideration as described above apply. However, in plant configurations according to Figure 5, the feed gas has a pressure of between about 550psig and about 800psig, and most preferably between about 600psig and about 750psig. It should be particularly appreciated that operation of the absorber at a higher pressure allows that the feed gas is fed into the absorber without passing through a turboexpander. Consequently, the pressure in the absorber bottoms product (which is preferably

rich in methane) may advantageously be employed for refrigeration of various streams in the plant.

Thus, it is contemplated that the absorber bottoms product stream is expanded to reduce the bottoms product stream pressure in a range of about 50psi to about 350psi, and more preferably in a range of about 100psi to about 250psi. Consequently, it is contemplated that the bottoms product stream will have a temperature between -30°F to -80°F, and more typically between about between -50°F to -70°F. While not limiting to the inventive subject matter, it is generally contemplated that the expanded bottoms product stream is fed as the distillation column feed stream into the distillation column below the top of the distillation column, and it is preferred that the expanded bottoms product stream is fed into the distillation column at a position that is at least three trays below an upmost tray in the distillation column. With respect to the liquid portion of the feed gas, it is generally preferred that at least a portion of the feed gas is fed into a lower section of the distillation column.

It should further be appreciated that during propane recovery, the absorber bottoms after it is used to chill the absorber overhead reflux, is further utilized (if residual refrigeration is available) to cool the de-ethanizer overhead vapor providing reflux to the de-ethanizer. The heated absorber bottoms product stream at about -30°F to about -50°F is fed to a feed tray located at least 3 trays from the utmost top of the de-ethanizer. This arrangement improves the overall fractionation performance of the de-ethanizer by providing reflux and additional rectification utilizing the refrigeration content by the JT of the absorber bottoms. The de-ethanizer operates at an overhead temperature between -20 to -55°F.

With respect to the de-ethanizer it should be especially appreciated that the de-ethanizer produces an overhead stream that is cooled, and fed into the absorber as the absorber reflux stream, thereby providing a particularly lean stream (stream 13 containing 75 mol% methane and 25 mol% ethane) that may be employed to recover the propane and heavier components from the feed gas stream. Thus, contemplated configurations according to Figure 5 receive a feedstock that comprises propane, and provide a distillation column product stream that comprises at least 95% of the propane in the feedstock.

In a still further contemplated aspect of the inventive subject matter, contemplated configurations may further be employed in a gas processing plant for ethane recovery from a

feed gas. **Figure 3** depicts a prior art configuration in which a feed gas stream 1 at a pressure of about 1300psig is cooled and separated into a gaseous portion 4 and liquid portion 5. The gaseous portion is split in two streams, and the first stream cooled and JT expanded, while the second stream is passed through a turboexpander. Both streams are then fed into different
5 locations in the demethanizer. The demethanizer operates at about 430psig. The demethanizer overhead provides cooling for the first stream and is recompressed by the turboexpander and further compressed by the residue gas compressor before leaving the plant as residue gas. Typical ethane recovery is about 80%, and the CO₂ content in the ethane product is about 2 to 6%.

10 In contrast, an ethane recovery plant configurations according to the inventive subject matter as shown in **Figure 4** has a refluxed absorber 103 that is operated at a pressure of about 590psig and a de-ethanizer 106 that is operated at a pressure of about 450psig, while the feed gas stream 1 has a pressure of about 1300psig. The feed gas stream 1 is split into a first portion 2a and a second portion 2b. The first portion 2a is cooled in heat exchanger 100 and the second
15 portion 2b is cooled in heat exchanger 116. The respective cooled feed gas streams 3a and 3b are combined and separated in a separator 101 in a liquid portion 5 and a gaseous portion 4. The liquid portion 5 (if present) is fed into the absorber 103 after JT expansion in JT valve 115, while the gaseous portion 4 is expanded in a turboexpander 102 to the level of the operating pressure of the absorber 103. Expanded gaseous portion 6 is then fed into a lower portion of the
20 absorber 103. The absorber 103 receives a reflux stream 19, which is provided by the demethanizer overhead stream 13 of the demethanizer 106. The overhead stream 13 is separated in a separator 107 in a gaseous phase 15 and a liquid phase 16. Liquid phase 16 is pumped back to the demethanizer as demethanizer reflux via pump 108, while gaseous phase 15 is compressed in compressor 111 and cooled in the heat exchanger 100 before entering the absorber as reflux
25 stream 19.

The absorber bottoms stream 7 is expanded in JT valve 104, thereby lowering the pressure in an amount of about 110psi and significantly cooling the absorber bottoms stream. The cooled absorber bottoms stream 8 is then employed as a coolant in the heat exchanger 100 before entering demethanizer 106 as demethanizer feed stream 11. Absorber overhead stream 9
30 is heated in the heat exchanger 100 and recompressed in recompressor 112 (which is operationally coupled to the turboexpander). Recompressed overhead stream 21 is further compressed in a residue gas compressor 113 and fed into a residue gas pipeline. The

demethanizer bottoms stream 12 provides liquid product at an ethane recovery of at least 69.0% and a CO₂ content of no more than 500ppm. Two side reboilers, located in the top section of the demethanizer, withdraw distillation liquids stream 109A and 109B. These streams are coupled to the distillation column and provide heat duties for the bulk removal of CO₂ from the liquid product, and further provide cooling of the first portion of the feedstock by stream 109A and 109B. The residual CO₂ is removed in the bottom reboiler 110.

Suitable feed gases are contemplated to have a pressure of between 1000psig and 2000psig. Consequently, it is preferred that at least a portion of the feed gas is expanded in a turboexpander. Further cooling is provided by expanding the bottoms product stream in a range of 100-250psi. Consequently, it is contemplated that the expanded bottoms product stream has a temperature between -95°F to -125°F.

With respect to the de-methanizer it should be especially appreciated that the demethanizer column produces an overhead stream that is compressed, cooled, and fed into the absorber as the absorber reflux stream, thereby providing a particularly lean stream (stream 13 containing over 90 mol% methane) that may be employed to recover the ethane and heavier components from the expanded feed gas streams. Thus contemplated configurations according to Figure 4 receive a feedstock that comprises ethane and propane, and provide a distillation column product stream that comprises at least 60% of the ethane and 95% of the propane in the feedstock

It should be particularly recognized that contemplated configurations according to Figure 4 can be used for a recovery of up to 75% ethane without appreciable increase in capital and operating costs for ethane recovery when the system can be used for high propane recovery of Figure 2. In an especially contemplated configuration, the feed tray location to the demethanizer is routed to the top of the demethanizer, and the overhead reflux condenser 105 in Figure 2 may be converted for use as a side reboiler 116 of the demethanizer in Figure 4. Additional side-reboilers, and external refrigeration may be used to improve the overall energy efficiency. The demethanizer overhead reflux system is bypassed in this operation and the demethanizer now operates as a reboiled stripper (as compared to a fractionator during propane recovery). The basic equipment design and arrangement in the upstream system is maintained as in Figure 2, but with a lower operating temperature. The absorber overhead operates then at a lower temperature of

about -100°F to about -130°F, and the feed temperature to the demethanizer is at a lower temperature of about -100°F to about -120°F.

It should further be appreciated that the previously known recovery plants designed for propane recovery can recover ethane in a range of 20% to 40%. In contrast, configurations according to the inventive subject matter, with minor changes in operation and process parameters, can be economically used for ethane recovery up to 75%. Moreover, the ethane produced in previously known recovery plants designed for ethane recovery usually contains 2-6% CO₂. In contrast, configurations according to the inventive subject matter will allow ethane recovery in which the CO₂ is present in the ethane in an amount of less than 500ppm, and more typically less than 350ppm.

With respect to all components of contemplated configurations (*e.g.*, heat exchangers, pumps, valves, compressors, expanders, refluxed absorbers, de-ethanizers, etc.) it should be appreciated that all known and commercially available components are suitable for use in conjunction with the teachings presented herein. It is further generally contemplated that configurations according to the inventive subject matter may find wide applicability in gas plant applications where high propane recovery is desirable, and feed gas is available at pressure greater than 550 psig. Moreover, such configurations may advantageously reduce equipment and operating costs, especially where turboexpander technology would necessitate feed gas and/or residue gas compression. For gas plant applications where energy cost is relatively high and propane value compared to fuel value is marginal, it is contemplated that preferred design configurations greatly reduce the overall energy compression costs by operating the absorber between 600 to 750 psig while maintaining the propane recovery between 85% to 95%. Furthermore, it should be appreciated that by combining the reflux absorber and de-ethanizer in a single column as shown in Figure 6, the overall plot space requirement may be reduced, which may result in substantial cost savings in modular and platform design.

Examples

Operations of gas processing plants according to Figures 1, 2, 3, 4, and 5 were computer simulated using process simulator HYSYS, and Tables 1, 2, 3, 4, and 5 below summarize exemplary component flow, pressures and temperatures in the configurations as shown in Figure 1-5, respectively.

Furthermore, calculations were performed to project the heat composite curve for the heat exchanger 100 in plant configuration according to Figure 2, the heat exchanger 100 in plant configuration according to Figure 4, and the side heat exchanger 116 in plant configuration according to Figure 4, and the results are depicted in Figures 2A, 4A, and 4B, respectively. The energy efficiencies of these inventions are very high that are demonstrated by the relatively close temperature approaches of these composite curves.

Thus, specific embodiments and applications for high propane recovery processes and configurations have been disclosed. It should be apparent, however, to those skilled in the art that many more modifications besides those already described are possible without departing from the inventive concepts herein. The inventive subject matter, therefore, is not to be restricted except in the spirit of the appended claims. Moreover, in interpreting both the specification and the claims, all terms should be interpreted in the broadest possible manner consistent with the context. In particular, the terms "comprises" and "comprising" should be interpreted as referring to elements, components, or steps in a non-exclusive manner, indicating that the referenced elements, components, or steps may be present, or utilized, or combined with other elements, components, or steps that are not expressly referenced.

76186-35

CLAIMS:

1. A gas processing plant comprising:
a refluxed absorber operating at a first pressure, producing
a bottoms product stream and receiving a feedstock and an
5 absorber reflux stream;
a distillation column fluidly coupled to the absorber,
receiving a distillation column feed stream, producing a
distillation column overhead stream, and operating at a
second pressure that is at least 100 psi lower than the
10 first pressure; and
an expansion device coupled to the absorber and configured
to expand at least a portion of the bottoms product stream
to thereby generate an expanded bottoms product stream and
to thereby provide cooling for at least one of the absorber
15 reflux stream and the distillation column feed stream; and
wherein the distillation column overhead stream is separated
into a liquid portion that provides reflux for the
distillation column and a gaseous portion that is liquefied
and provides the absorber reflux stream.
- 20 2. The gas processing plant of claim 1 wherein the
distillation column comprises a de-ethanizer column.
3. The gas processing plant of claim 2 wherein the
feedstock is at a pressure of between 1000 psig and
2000 psig.
- 25 4. The gas processing plant of claim 3 wherein at
least a portion of the feedstock is expanded in a
turboexpander.

76186-35

5. The gas processing plant of claim 3 wherein the bottoms product stream has a pressure and wherein expanding the bottoms product stream reduces the bottoms product stream pressure in a range of 100-250 psi.
- 5 6. The gas processing plant of claim 3 wherein the expanded bottoms product stream has a temperature between -95°F to -125°F.
7. The gas processing plant of claim 3 wherein the expanded absorber bottoms product stream is fed as the
10 distillation column feed stream into the distillation column at a position that is at least three trays below an upmost tray of the distillation column.
8. The gas processing plant of claim 3 wherein the expanded bottoms product stream further provides cooling for
15 a distillation column overhead stream.
9. The gas processing plant of claim 3 wherein the distillation column overhead stream is compressed, cooled, and fed into the absorber as the absorber reflux stream.
10. The gas processing plant of claim 3 wherein the
20 feedstock comprises propane, and wherein the distillation column is configured to produce a distillation column product stream, and wherein the distillation column product stream comprises at least 95% of the propane in the feedstock.
- 25 11. The gas processing plant of claim 2 wherein the feedstock is at a pressure of between 550 psig and 800 psig.
12. The gas processing plant of claim 11 wherein the feedstock is fed into the absorber without passing through a turboexpander.

76186-35

13. The gas processing plant of claim 11 wherein the bottoms product stream has a pressure and wherein expanding the bottoms product stream reduces the bottoms product stream pressure in a range of 100-250 psi.

5 14. The gas processing plant of claim 11 wherein the bottoms product stream has a temperature between -50°F to -70°F.

15. The gas processing plant of claim 11 wherein the expanded bottoms product stream is fed as the distillation
10 column feed stream into the distillation column at a position that is at least three trays below an upmost tray in the distillation column.

16. The gas processing plant of claim 11 wherein at least a portion of the feedstock is fed into a lower section
15 of the distillation column.

17. The gas processing plant of claim 11 further comprising an external refrigeration coupled to the distillation column.

18. The gas processing plant of claim 1 wherein the
20 distillation column comprises a demethanizer.

19. The gas processing plant of claim 18 wherein the feedstock is at a pressure of between 1000 psig and 2000 psig.

20. The gas processing plant of claim 18 wherein at
25 least a portion of the feedstock is expanded in a turboexpander.

21. The gas processing plant of claim 18 wherein the bottoms product stream has a pressure and wherein expanding

76186-35

the bottoms product stream reduces the bottoms product stream pressure in a range of 100-250 psi.

22. The gas processing plant of claim 18 wherein the expanded bottoms product stream has a temperature between
5 -95°F to -125°F.

23. The gas processing plant of claim 18 wherein the expanded bottoms product stream is fed as the distillation column feed stream into the distillation column.

24. The gas processing plant of claim 18 wherein the
10 distillation column produces a methane rich distillation column overhead stream that is compressed, cooled, and fed into the absorber as the absorber reflux stream.

25. The gas processing plant of claim 18 wherein the
15 distillation column is configured to produce a distillation column product stream, and wherein the distillation column product stream comprises no more than 500 ppm carbon dioxide.

26. The gas processing plant of claim 18 wherein the
20 feedstock is split into a first portion and a second portion, and wherein an external refrigeration cools at least part of the first portion.

27. The gas processing plant of claim 26 further
25 comprising at least one side reboiler coupled to the distillation column, wherein the at least one side reboiler is fluidly coupled to the demethanizer between a top tray and a position eight trays below the top tray, provides heat duty for stripping CO₂ from a demethanizer product stream, provides reboiling of the distillation column, and further provides cooling of the first portion of the feedstock.

76186-35

28. The gas processing plant of claim 1, wherein the absorber and the distillation column are configured into a single tower configuration.

SMART & BIGGAR
OTTAWA, CANADA
PATENT AGENTS

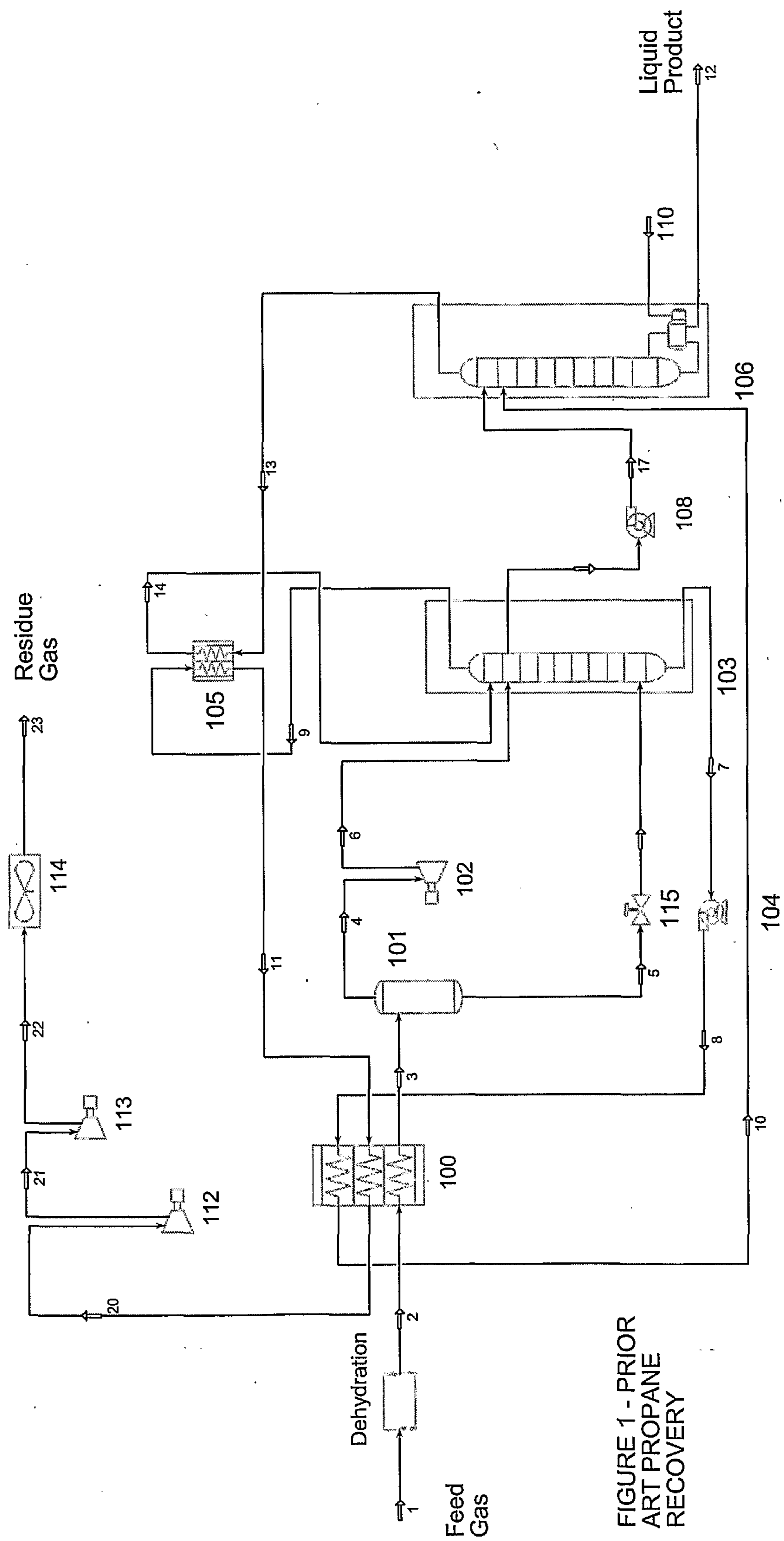

FIGURE 1 - PRIOR ART PROPANE RECOVERY

TABLE 1 - STREAM SUMMARY FOR FIGURE 1 PROPANE RECOVERY - PRIOR ART

Stream Number	1	2	3	4	5	6	7	8
Temp., °F	68	67	-22	-22	-22	-100	-101	-100
Pressure, psig	1300	1275	1268	1268	1268	449	447	470
Flow, lbmol/hr	109,805	109,805	109,805	109,805	-	109,805	20,796	20,796
Stream Number	9	10	11	12	13	14	17	18
Temp., °F	-102	57	-25	203	-20	-75	-75	-75
Pressure, psig	445	463	440	453	450	445	470	445
Flow, lbmol/hr	105,703	20,796	105,703	4,100	33,395	33,395	16,700	21,800
Stream Number	19	20	21	22	23			
Temp., °F	-75	24	73	201	110			
Pressure, psig	445	433	600	1315	1300			
Flow, lbmol/hr	11,595	105,703	105,703	105,703	105,703			

Key Stream Component Flow (lbmol/hr)

Stream Number	1	7	9	12	13	16	17	23
CO2	1,647	608	1,647	0	1,446		838	1,647
N2	471	15	471	0	19		3	471
C1	97,044	11,907	97,043	0	19,095		7,188	97,043
C2	6,582	4,217	6,528	54	12,831		8,667	6,528
C3	2,988	2,976	13	2,975	5		4	13
IC4	327	327	0	327	0		0	0
NC4	488	488	0	488	0		0	0
IC5	125	125	0	125	0		0	0
NC5	124	124	0	124	0		0	0
NC6	9	9	0	9	0		0	0
Recoveries:								
Propane								99.5%
Butanes+								100.0%
Residue Gas Compressor								43,000 HP
								43.00 HP/MMscfd

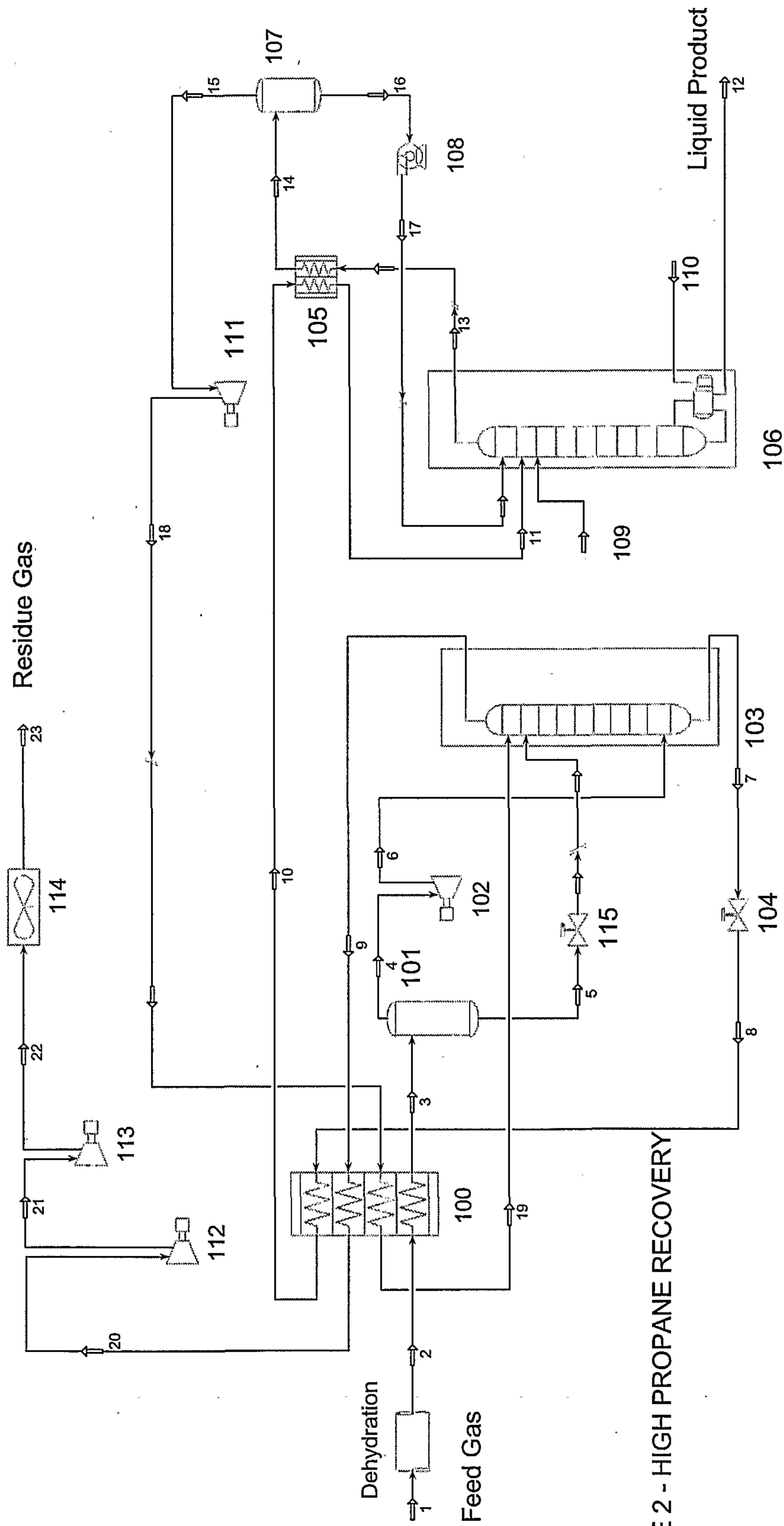
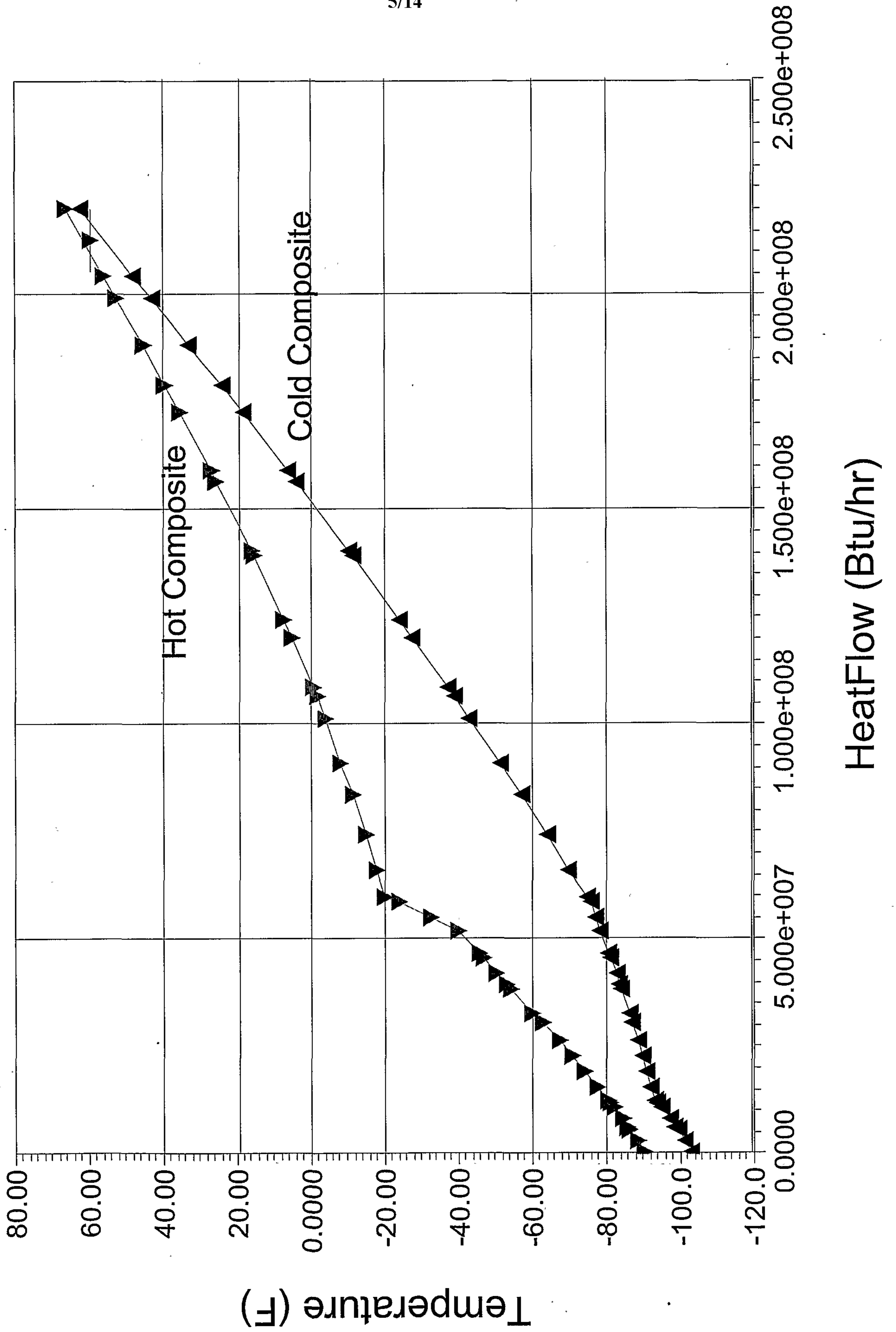

FIGURE 2 - HIGH PROPANE RECOVERY

Figure 2A - High Propane Recovery Composite Curve



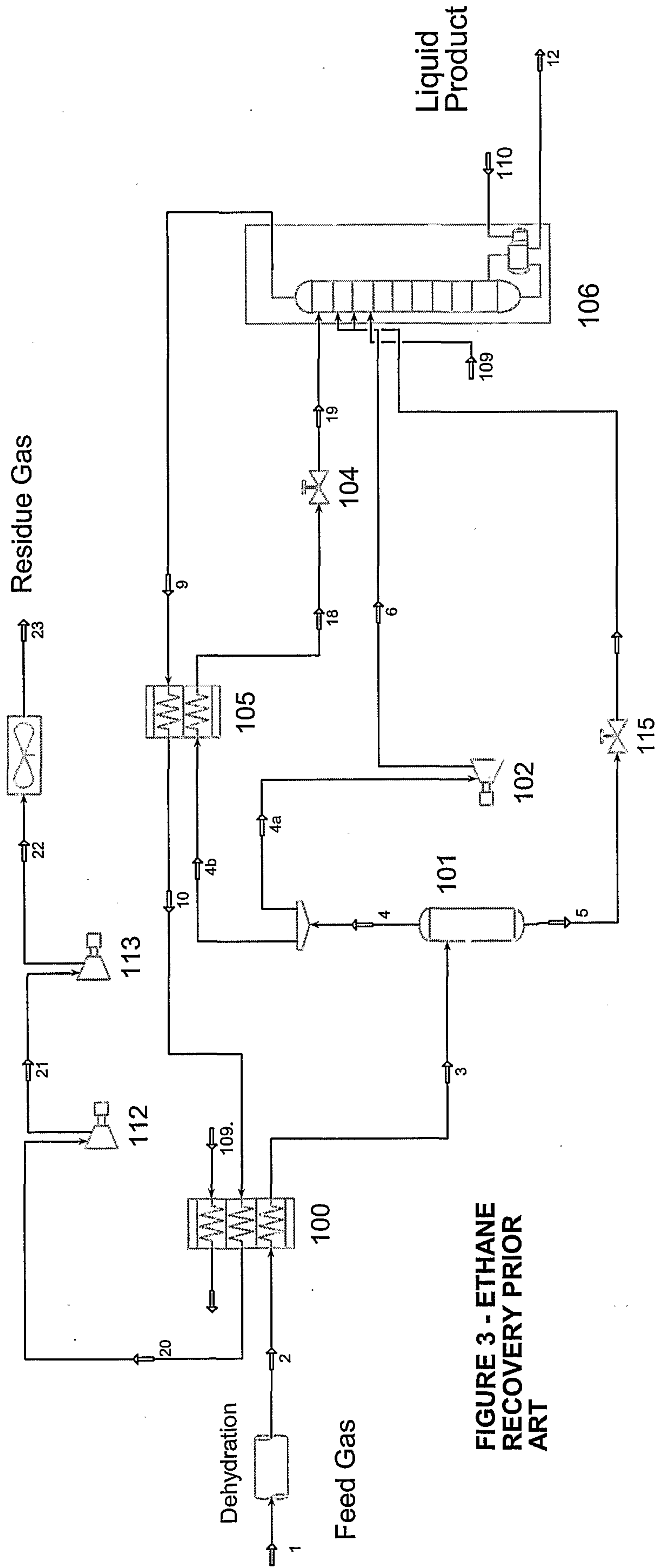

FIGURE 3 - ETHANE RECOVERY PRIOR ART

TABLE 3 - STREAM SUMMARY FOR FIGURE 3 ETHANE RECOVERY - PRIOR ART

Stream Number	1	2	3	4	4a	4b	5	6
Temp., °F	68	67	35	35	35	35	35	-62
Pressure, psig	1300	1275	1268	1268	1268	1268	1268	429
Flow, lbmol/hr	109,805	109,805	109,805	109,805	64,236	45,569	-	64,236
Stream Number	9	10	12	16	18	19	20	21
Temp., °F	-125	18	97	55	-121	-132	31	76
Pressure, psig	425	420	428	427	1263	429	415	558
Flow, lbmol/hr	100,496	100,496	9,309	22,201	45,569	45,569	100,496	100,496
Stream Number	22	23	109					
Temp., °F	220	110	32					
Pressure, psig	1315	1300	427					
Flow, lbmol/hr	100,496	100,496	22,201					

Key Stream Component Flow (lbmol/hr)

Stream Number	1	9	12	23
CO2	1,647	1,542	105	1,542
N2	471	471	0	471
C1	97,044	97,043	1	97,043
C2	6,582	1,347	5,236	1,347
C3	2,988	87	2,901	87
IC4	327	3	324	3
NC4	488	3	485	3
IC5	125	0	124	0
NC5	124	0	124	0
NC6	9	0	9	0
Recoveries:				
Ethane		79.5%		
Propane		97.1%		
Butanes+		99.4%		
Residue Gas Compressor		46,230 HP		46.23 HP/MMScfd
CO2 in C2		2.0%		

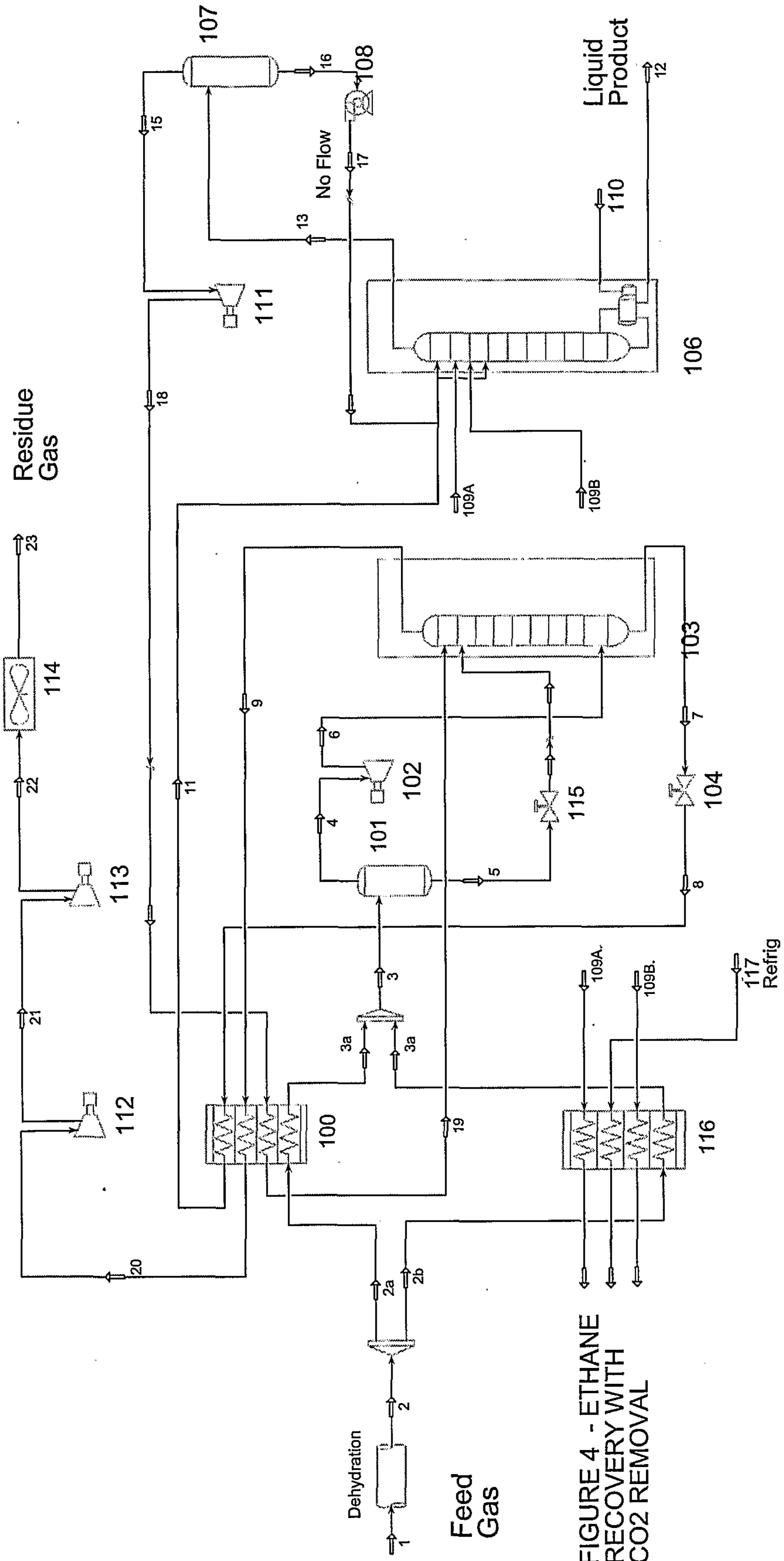

FIGURE 4 - ETHANE RECOVERY WITH CO2 REMOVAL

TABLE 4 - STREAM SUMMARY FOR FIGURE 4 ETHANE RECOVERY

	1	2	3	4	5	6	7	8
Stream Number	68	67	-50	-50	-50	-101	-104	-116
Temp., °F	1300	1275	1268	1268	1268	589	587	475
Pressure, psig	109,805	109,805	109,805	109,805	-	109,805	66,995	66,995
Flow, lbmol/hr								
Stream Number	9	11	12	13	15	16	17	18
Temp., °F	-111	-108	110	-90	-90	-90	-81	-56
Pressure, psig	585	472	450	448	448	448	485	595
Flow, lbmol/hr	101,195	66,995	8,580	58,416	58,416	-	-	58,416
Stream Number	19	20	21	22	23	109A.	109B.	117
Temp., °F	-111	62	87	198	110	-27	-89	6
Pressure, psig	588	575	675	1315	1300	449	458	28
Flow, lbmol/hr	58,386	101,195	101,195	101,195	101,195	21,550	33,597	4,105

Key Stream Component Flow (lbmol/hr)

Stream Number	7	9	11	12	13	17	23
CO2	1,647	1,723	1,644	1,723	1,720	-	1,644
N2	471	117	471	117	117	-	471
C1	97,044	53,038	97,016	53,038	53,038	-	97,016
C2	6,582	7,870	2,013	7,870	3,302	-	2,013
C3	2,988	3,162	50	3,162	224	-	50
IC4	327	334	1	334	7	-	1
NC4	488	494	1	494	7	-	1
IC5	125	125	0	125	1	-	0
NC5	124	124	0	124	0	-	0
NC6	9	9	0	9	0	-	0

Recoveries:

Ethane 69.4%

Propane 98.3%

Butanes+

Residue Gas Compressor 35,592 HP

DeC2 Ovhd Compressor 4,489

Refrigeration 4,728

Total HP 44,809

CO2 in Ethane 500 ppm

44.81 HP/MMscfd

Figure 4A - Ethane Recovery Composite Curve for Feed Exchanger 100

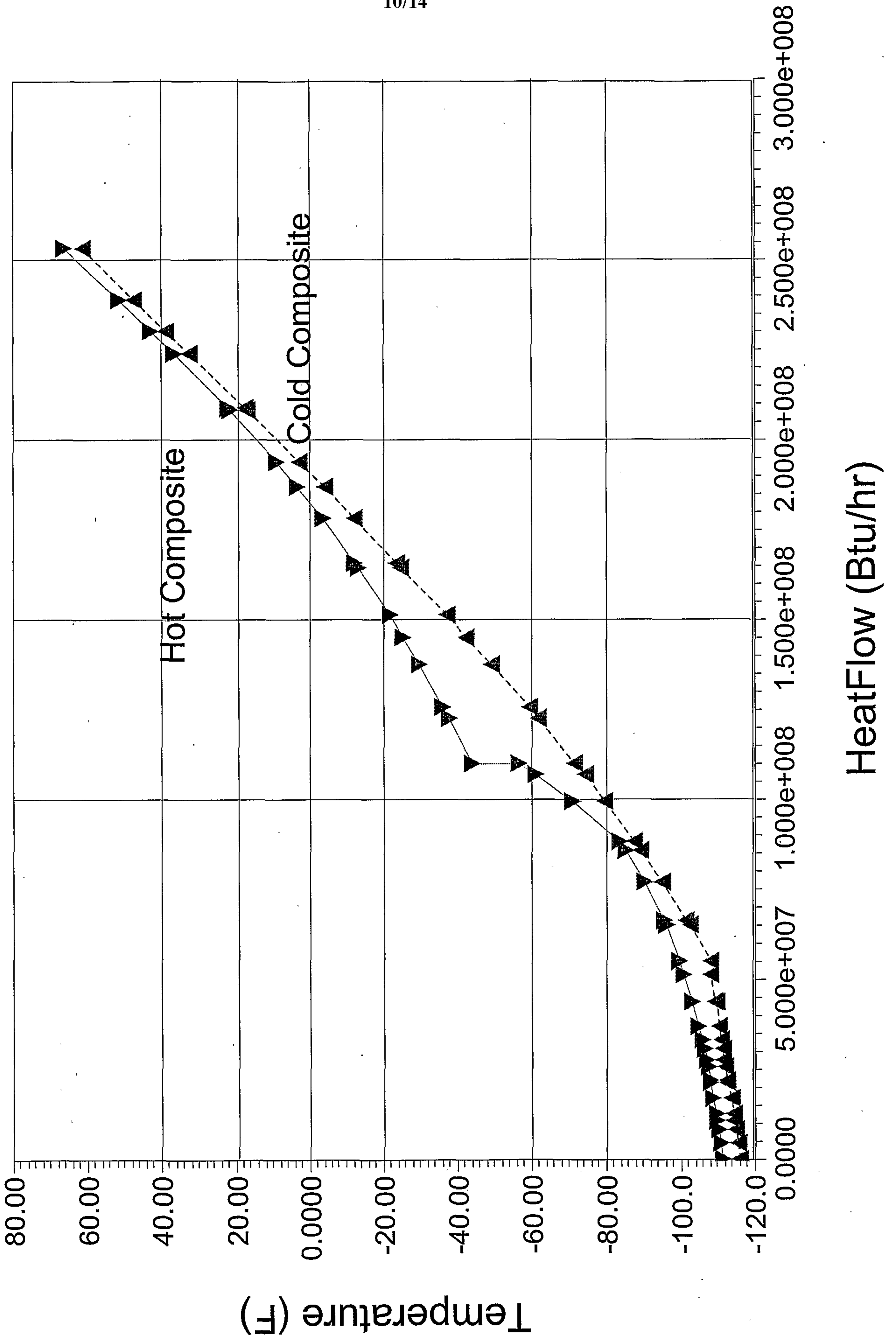
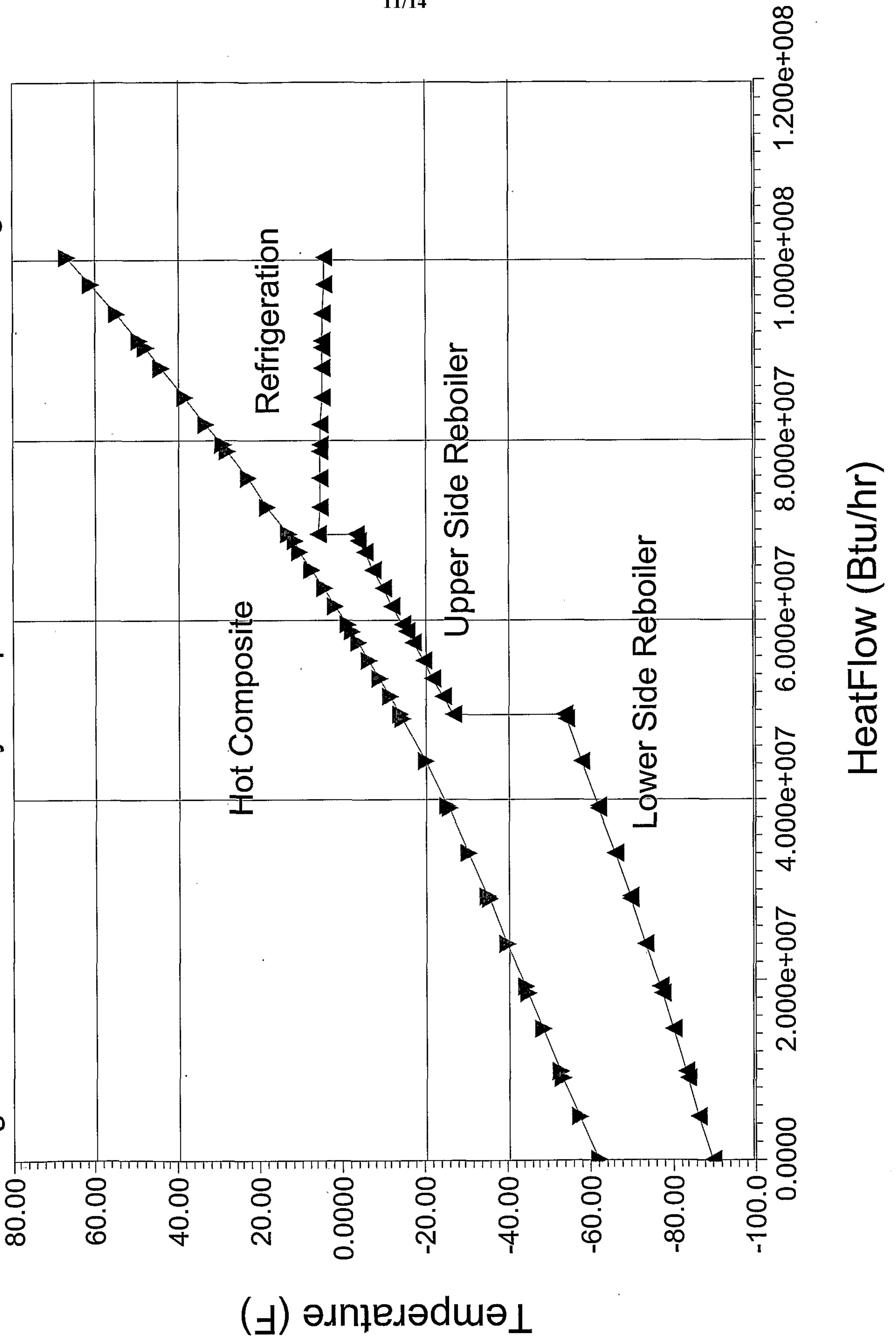

Figure 4B - Ethane Recovery Composite Curve for Side Exchanger 116



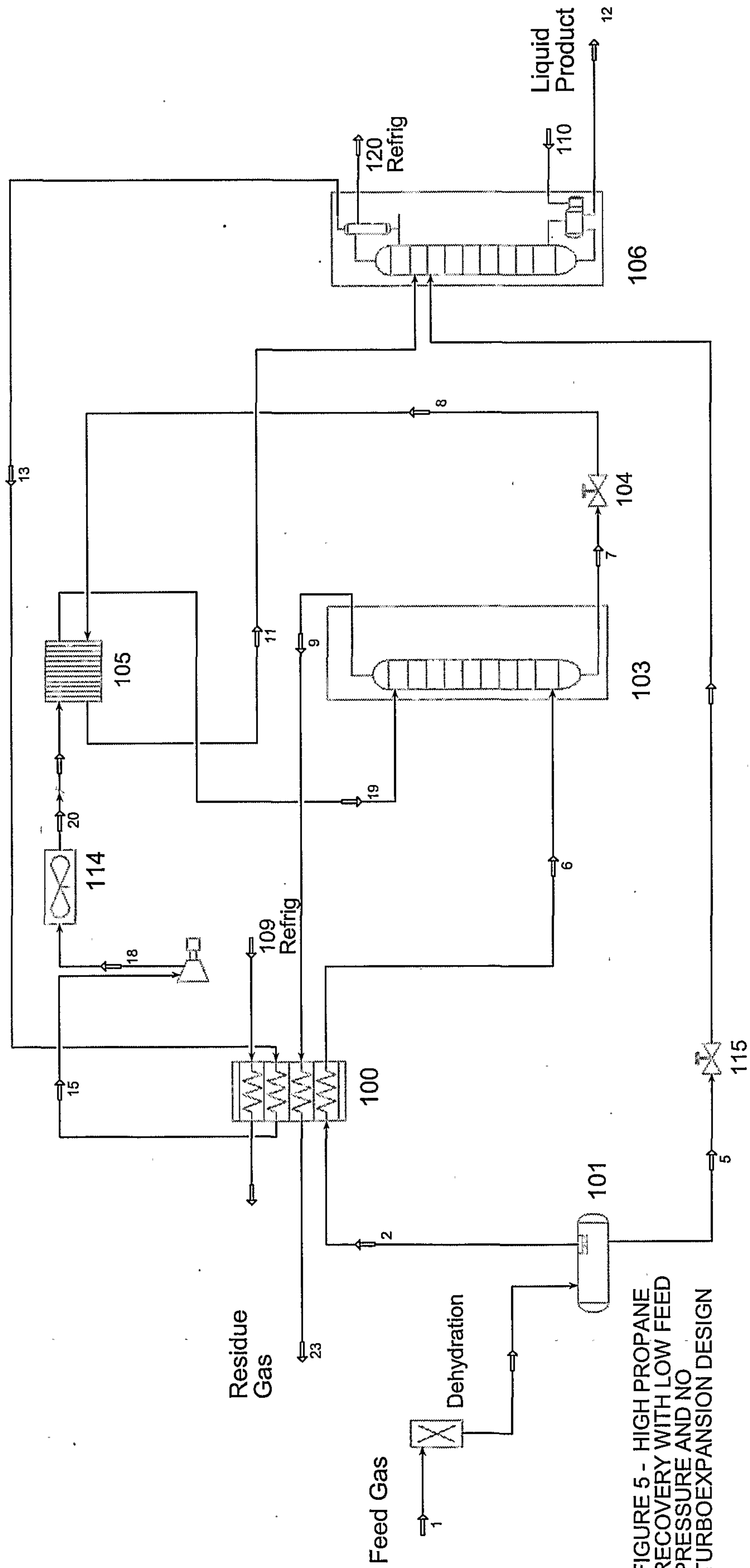

FIGURE 5 - HIGH PROPANE RECOVERY WITH LOW FEED PRESSURE AND NO TURBOEXPANSION DESIGN

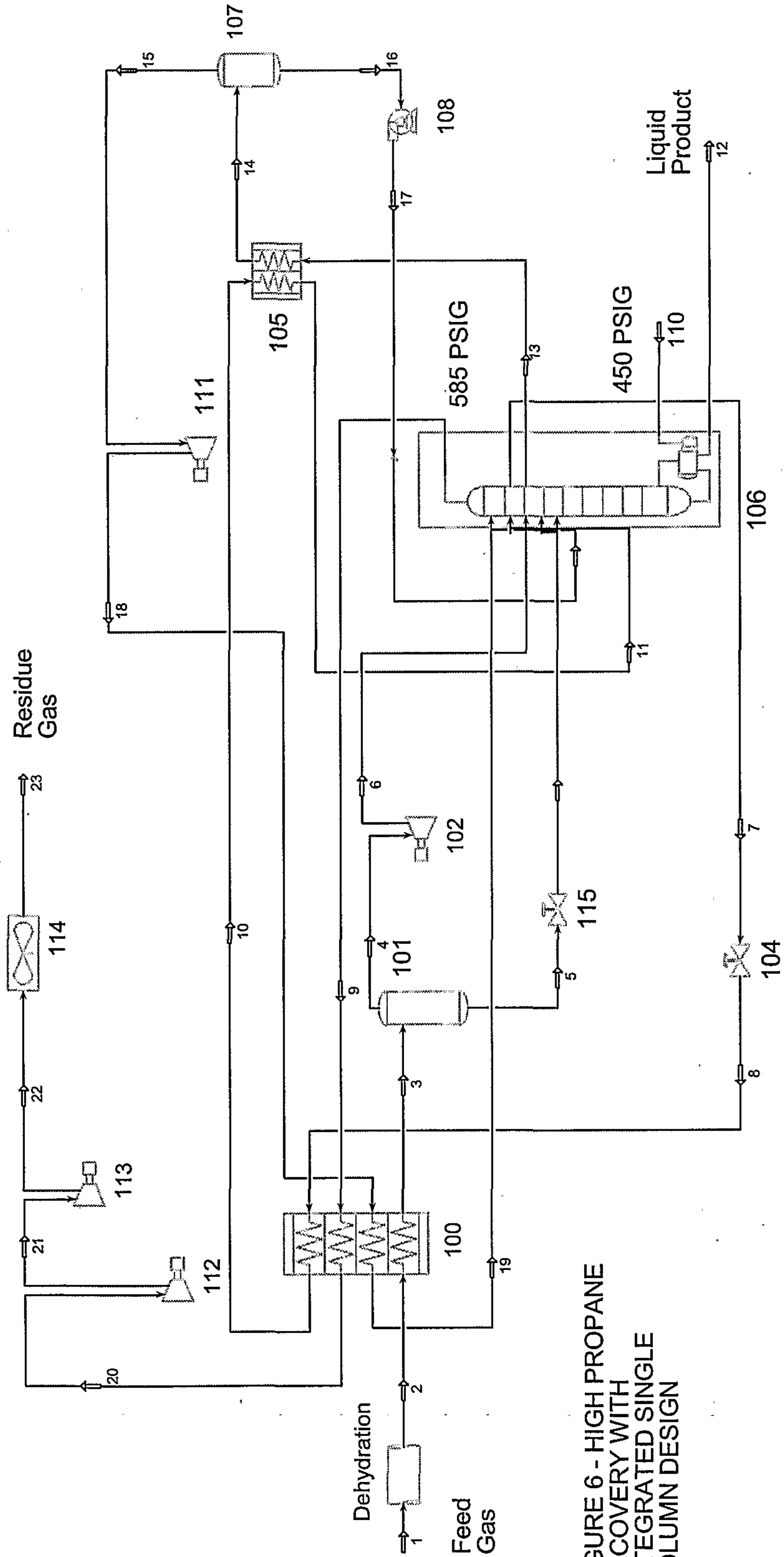

FIGURE 6 - HIGH PROPANE RECOVERY WITH INTEGRATED SINGLE COLUMN DESIGN

