

(19) World Intellectual Property  
Organization  
International Bureau



(43) International Publication Date  
11 March 2004 (11.03.2004)

PCT

(10) International Publication Number  
**WO 2004/020325 A2**

- (51) International Patent Classification<sup>7</sup>: **B67D**
- (21) International Application Number:  
PCT/US2003/027144
- (22) International Filing Date: 27 August 2003 (27.08.2003)
- (25) Filing Language: English
- (26) Publication Language: English
- (30) Priority Data:  
10/229,672 27 August 2002 (27.08.2002) US  
10/608,045 27 June 2003 (27.06.2003) US
- (71) Applicant: **HYMORE, INC.** [US/US]; 31645 Canyon Circle, Evergreen, CO 80439 (US).
- (72) Inventor: **MATHUES, John, H.**; 31645 Canyon Circle, Evergreen, CO 80439 (US).
- (74) Agent: **BRUESS, Steven, C.**; Merchant & Gould P.C., P.O. Box 2903, Minneapolis, MN 55402-0903 (US).
- (81) Designated States (*national*): AE, AG, AL, AM, AT (utility model), AT, AU, AZ, BA, BB, BG, BR, BY, BZ, CA, CH, CN, CO, CR, CU, CZ (utility model), CZ, DE (utility model), DE, DK (utility model), DK, DM, DZ, EC, EE (utility model), EE, ES, FI (utility model), FI, GB, GD, GE, GH, GM, HR, HU, ID, IL, IN, IS, JP, KE, KG, KP, KR, KZ, LC, LK, LR, LS, LT, LU, LV, MA, MD, MG, MK, MN, MW, MX, MZ, NO, NZ, OM, PG, PH, PL, PT, RO, RU, SC, SD, SE, SG, SK (utility model), SK, SL, SY, TJ, TM, TN, TR, TT, TZ, UA, UG, UZ, VC, VN, YU, ZA, ZM, ZW.
- (84) Designated States (*regional*): ARIPO patent (GH, GM, KE, LS, MW, MZ, SD, SL, SZ, TZ, UG, ZM, ZW), Eurasian patent (AM, AZ, BY, KG, KZ, MD, RU, TJ, TM), European patent (AT, BE, BG, CH, CY, CZ, DE, DK, EE, ES, FI, FR, GB, GR, HU, IE, IT, LU, MC, NL, PT, RO, SE, SI, SK, TR), OAPI patent (BF, BJ, CF, CG, CI, CM, GA, GN, GQ, GW, ML, MR, NE, SN, TD, TG).

**Published:**

— without international search report and to be republished upon receipt of that report

For two-letter codes and other abbreviations, refer to the "Guidance Notes on Codes and Abbreviations" appearing at the beginning of each regular issue of the PCT Gazette.



**WO 2004/020325 A2**

(54) Title: BEVERAGE SUPPLY SYSTEM

(57) Abstract: A beverage supply system includes a beverage container having an outlet. A first reservoir is connected to the beverage container outlet to receive beverage from the beverage container under force of gravity. A pump is connected to the first reservoir, and a second reservoir is connected to the pump, the second reservoir defining an expandable beverage chamber. The pump is activated to pump beverage from the first reservoir to the second reservoir only when a first quantity of beverage in the first reservoir is within a first quantity range and a second quantity of beverage in the second reservoir is below a second quantity range. The system also includes a beverage dispenser connected to the second reservoir. A method of supplying beverage from a beverage container to a beverage dispenser includes supplying beverage from a beverage container to a first reservoir under force of gravity. The method also includes pumping the beverage from the first reservoir to an expandable pressurized chamber of a second reservoir when a first quantity of beverage in the first reservoir is within a first quantity range and a second quantity of beverage in the second reservoir is below a second quantity range. The method additionally includes intermittently connecting the pressurized chamber to an outlet of a beverage dispenser to supply beverage from the second reservoir to the beverage dispenser without pumping the beverage from the second reservoir to the beverage dispenser.

## **BEVERAGE SUPPLY SYSTEM**

HYMORE, INC, a United States national and resident, is filing this  
5 application as a PCT application designating all countries except US, claiming  
priority to US Patent Application No. 10/229,672 filed 27 August 2002 and US  
Patent Application No. 10/608,045 filed 27 June 2003.

### **Field of the Invention**

10 This application relates generally to bottled beverage supply systems and  
more particularly to a bottled beverage supply system that pumps beverage to a  
reservoir, which in turn supplies the beverage to a dispenser.

### **Background of the Invention**

Due to high levels of impurities found in many domestic water supplies, a  
15 substantial number of households and offices prefer not to use their domestic water  
supplies as a source of drinking water, when making ice, or when making coffee or  
the like. As a consequence, such households frequently purchase bottled water for  
such uses. While there are numerous devices for dispensing bottled water and other  
bottled beverages for drinking purposes, it is considerably more difficult to supply  
20 bottled water to the icemaker or chilled water dispenser of a refrigerator. Typically,  
a water supply line for a refrigerator is connected directly to the domestic water  
supply, perhaps with a filter installed between them. Thus, if bottled water is to be  
supplied to a refrigerator, it should be supplied under a pressure comparable to that  
of the domestic water supply system.

25 Prior devices for supplying pressurized bottled water to a refrigerator or  
other water dispenser have not proven to be commercially viable. For example,  
some such systems have often required activation of a pump each time water is  
supplied to the dispenser. Thus, each time a user gets water from a refrigerator or  
otherwise uses the water supply, the pump is activated. This is both an annoyance to  
30 the user and a waste of energy. Other systems have required the use of a dip leg and  
its attendant inefficiencies, such as wasted water.

Accordingly there is a need for a reliable and convenient system for  
supplying water or other beverages from a bottle to a dispenser, such as a

refrigerator. The present invention provides a solution to this and other problems, and offers other advantages over the prior art.

### **Summary of the Invention**

Against this backdrop the present invention has been developed. An  
5 embodiment of the present invention is a beverage supply system. The system includes a beverage container having a bottom outlet. A first reservoir is connected to the beverage container outlet to receive beverage from the beverage container under force of gravity. A pump is connected to the first reservoir, and a second reservoir is connected to the pump, the second reservoir defining an expandable  
10 beverage chamber. The pump is activated to pump beverage from the first reservoir to the second reservoir only when a first quantity of beverage in the first reservoir is within a first quantity range and a second quantity of beverage in the second reservoir is below a second quantity range. The system also includes a beverage dispenser connected to the second reservoir.

15 Stated another way, an embodiment of the present invention is a beverage supply system that includes a first reservoir adapted to receive beverage from a beverage container under force of gravity within a first quantity range. The system also includes a pump connected to the first reservoir, and a second reservoir connected to the pump. The second reservoir includes a solid barrier adapted to  
20 press against a second quantity of beverage within the second reservoir as the second quantity of beverage within the second reservoir displaces the barrier to produce a pressure. The second reservoir is adapted to supply beverage to a beverage dispenser without the pump being operated. The pump is activated to pump beverage from the first reservoir to the second reservoir only when a first quantity of  
25 beverage in the first reservoir is within the first quantity range and a second quantity of beverage in the second reservoir is below a second quantity range.

Stated yet another way, an embodiment of the present invention is a method of supplying beverage from a beverage container to a beverage dispenser. The method includes supplying beverage from a beverage container to a first reservoir.  
30 The method also includes pumping the beverage from the first reservoir to an expandable pressurized chamber of a second reservoir when a first quantity of beverage in the first reservoir is within a first quantity range and a second quantity of beverage in the second reservoir is below a second quantity range. The method

additionally includes intermittently connecting the pressurized chamber to an outlet of a beverage dispenser to supply beverage from the second reservoir to the beverage dispenser without pumping the beverage from the second reservoir to the beverage dispenser.

5           These and various other features as well as advantages which characterize the present invention will be apparent from a reading of the following detailed description and a review of the associated drawings.

### **Brief Description of the Drawings**

10           **FIG. 1** is a schematic diagram of the beverage supply system according to an embodiment of the present invention.

**FIG. 2** is a front perspective view of a beverage supply system according to an embodiment of the present invention.

**FIG. 3** is a rear perspective view of the beverage supply system of **FIG. 2**  
15 with its access door removed.

**FIG. 4** is a front separate perspective view of the support frame, the second reservoir, and the pump of the beverage supply system of **FIG. 2**.

**FIG. 5** is a sectional view taken along line 5-5 of **FIG. 2**.

**FIG. 6** is a separate sectional view of the second reservoir of the beverage  
20 supply system of **FIG. 2** with the beverage chamber empty.

**FIG. 7** is a separate sectional view similar to **FIG. 6**, but with the beverage chamber being partially filled.

**FIG. 8** is a separate sectional view similar to **FIG. 7**, but with the beverage chamber being more full than in **FIG. 7**.

25           **FIG. 9** is vertical sectional view of a beverage supply system in accordance with an alternative embodiment of the present invention.

**FIG. 10** is a schematic diagram of the alternative beverage supply system according to the present invention shown in **FIG. 9**.

**FIG. 11** is a rear perspective view of the alternative beverage supply system  
30 of **FIG. 9** with its access door removed.

### Detailed Description

Referring to **FIGS. 1-5**, a bottled beverage supply system **100** generally includes a beverage bottle or container **108**, such as a conventional water bottle, having an outlet **110** that feeds into a first reservoir **112**. A pump **114** pumps  
5 beverage from the first reservoir **112** to a pressurized second reservoir **116**. The beverage is then supplied from the second reservoir **116** to a beverage dispenser **118**. Because the second reservoir **116** is pressurized, beverage can be supplied from the second reservoir **116** to the beverage dispenser **118** without operating the pump **114**. The pump **114** only needs to be activated when the quantity of beverage in the  
10 second reservoir **116** becomes too low. Thus, the bottled beverage supply system **100** preferably supplies pressurized beverage to the beverage dispenser **118** in an efficient manner without requiring the pump **114** to be constantly operated while beverage is being supplied to the beverage dispenser **118**.

Referring still to **FIGS. 2-3** and **5**, and describing the bottled beverage  
15 supply system **100** in more detail, a housing **130** has a substantially rectangular front wall **132**, a pair of substantially rectangular side walls **134** extending back from opposite side edges of the front wall **132**, and a substantially rectangular rear wall **136** extending between the rear edges of the side walls **134**. A substantially rectangular door opening **142** in the rear wall **136** provides access to the interior  
20 space of the housing **130**. A housing collar **144** extending about the periphery of the door opening **142** protrudes rearward, and a lip **146** extends up from the rear edge of the top of the housing collar **144** to define a channel **148** between the lip **146** and the rear wall **136**. A substantially rectangular door **156** spans the door opening **142**, but includes a cutout **158** from its bottom edge to provide limited access to the interior  
25 space of the housing **130** while the door is mounted on the housing **130**. The door **156** also includes a door collar **160** extending forward from the periphery of the door **156** and a lip **162** extending down from the front edge of the top of the door collar **160**. The door collar **160** fits around the housing collar **144**, and the door lip **162** extends down into the channel **148** so that the door lip and the housing lip **146**  
30 interlock. The door **156** also includes fastener holes **164** near its bottom edge to facilitate fastening the bottom of the door **156** in place.

A floor **170** of the housing **130** joins the bottom edges of the front wall **132**, the side walls **134**, and the rear wall **136** to form a bottom closure of the housing

130. A support frame 172 is securely mounted on the floor 170 within the housing 130. The support frame 172 includes a horizontal base 174, a front wall 176 extending up from the front edge of the base 174, and a reservoir pedestal 178 rising above the base 174. A pair of reservoir support arms 180 extend up from front and rear sides of the reservoir pedestal 178 on opposite sides of the second reservoir 116.

A top wall 182 of the housing 130 joins the top edges of the front wall 132, the side walls 134, and the rear wall 136. A centrally located annular ridge 190 preferably protrudes upwardly from the top wall 182 and supports the body of the beverage bottle 108. Referring to FIG. 5, the first reservoir 112 includes an annular side wall 210 that depends from the top wall 182 inside the annular ridge 190. A sloped wall 212 slopes downward and inward from the side wall 210 to an outlet 214. The outlet 214 preferably empties into a fitting 216.

A drain apparatus 220 includes a support structure 222 that extends from the top wall 182 of the housing 130 down and into the first reservoir 112. The support structure 222 supports a mating surface 224 that preferably abuts the rim of the downwardly facing outlet 110 of the bottle 108. The support structure 222 is also preferably positioned and oriented to act as a guide to guide the outlet 110 toward the mating surface 224 when the bottle 108 is positioned on the beverage supply system 100. A drain tube 226 also supported by the support structure 222 preferably extends up into the outlet 110. The drain tube 226 includes top openings 228 at its upward end and a bottom opening 229 at its lower end. A drain tube flange 230 extends outwardly from the drain tube 226 and preferably seals with the mating surface 224. Water is thus supplied to the first reservoir 112 through the drain tube 226 until the level of beverage in the first reservoir rises to the bottom opening 229 and prevents air from entering the drain tube 226.

The housing 130, the first reservoir 112, the support structure 222 are all preferably part of a unitary member. The unitary member is preferably formed of structural polymer material such as a thermoplastic material. The unitary member can be formed by a roto-mold process. Alternatively, the body could be formed as separate members that are joined together. In this case, the body could be formed by a blow mold process.

A pump supply line 232 extends from the fitting 216 to the pump 114. The pump 114 is preferably a positively displaced pump that can produce at least about

100 pounds per square inch of pressure. Alternatively, the pump could be some other type of pump in combination with a check valve to prevent backflow through the pump when the pump is not operated. Pump mounts **240** that are preferably arranged to prevent the transmission of vibrations between the pump **114** and the front wall **176** preferably mount the pump to the front wall **176** of the support frame **172**.

A pump exit line **242** extends from an outlet of the pump **114** to a second reservoir line **244**. The second reservoir line **244** extends to the second reservoir **116**. The second reservoir **116** preferably includes a pressure tank **250** having an inlet and outlet opening **252** attached to the second reservoir line **244**. A solid barrier or diaphragm **254** is preferably a thin flexible member that is secured to the sides of the pressure tank **250** and divides the pressure tank **250** into a beverage chamber **256** that opens into the opening **252**, and a gas chamber **258** that is filled with a pressurized gas such as air.

Referring to **FIG. 1**, a dispenser supply line **260** extends from the second reservoir line **244** to the dispenser **118**. The dispenser **118** preferably includes a dispenser valve **266** attached to the dispenser supply line **260** and a dispenser exit line **268**. The dispenser exit line may be connected to a spigot, an icemaker, or any other device for supplying beverage in liquid or solid form to users.

The various beverage supply lines may be constructed of any suitable material, but they are preferably standard polyethylene tubing such as is often used in supplying drinking water to refrigerators or other beverage dispensers.

A power supply **270** preferably supplies alternating current electrical power, such as from a standard 120-volt outlet. A power switch power line **272** and a constant supply power line **273** are both connected to the power supply **270**, with each power line **272**, **273** at a different voltage. Accordingly, the power supply **270** will supply power to electrical components that are connected to both the power switch power line **272** and the constant supply power line **273**. The power switch power line **272** is connected to a power switch **274**, which switches between one position that connects the power switch power line **272** to a pressure switch power line **275** and another position that connects the power switch power line **272** to an indicator power line **276**.

The pressure switch power line **275** extends to the pump **114** via a pressure switch **280** that is pneumatically connected to the beverage chamber **256** of the second reservoir **116** via the second reservoir line **244**. The pressure switch **280** preferably closes when the pressure within the beverage chamber **256** drops below a pressure range, and preferably reopens when the pressure within the beverage chamber **256** rises above the pressure range. The pressure range is preferably within the required pressure range for the dispenser **118**. The pressure range preferably has a lower limit of from about thirty-five to about forty-five psi, and an upper limit of from about sixty to about seventy psi. In a preferred embodiment, the lower limit of the pressure range is about forty psi and the upper limit is about sixty-five psi so that the pressure range is from about forty psi to about sixty psi. Accordingly, in a preferred embodiment, the pressure switch **280** closes when the pressure within the beverage chamber **256** drops below forty psi, opens when the pressure within the beverage chamber **256** rises above sixty-five psi, and does not switch when the pressure within the beverage chamber **256** is within the pressure range between forty and sixty-five psi.

The pump **114** is constantly connected to the constant supply power line **273**. Thus, when the power switch **274** connects the power switch power line **272** to the pressure switch power line **275**, and the pressure switch **280** is closed, then the power supply **270** supplies power to the pump **114** and thereby activates the pump **114** to pump beverage from the first reservoir **112** to the second reservoir **116**.

The indicator power line **276** extends to an indicator light **282** that is preferably viewable by a user of the beverage supply system **100**. The indicator light **282** is also constantly connected to the constant supply power line **273** so that when the power switch **274** connects the power switch power line **272** to the indicator power line **276**, then the indicator light **282** receives power from the power supply **270** and is illuminated.

A fluid level switch power line **300** extends from the constant supply power line **273** to a fluid level switch **302**. The fluid level switch **302** is preferably driven by the fluid height of the beverage within the first reservoir **112**. Preferably, if sufficient beverage is within the first reservoir **112** to be pumped into the second reservoir **116**, then the fluid level switch **302** closes. Referring to **FIG. 5**, the fluid level switch preferably includes an annular float **304** that extends about a sealed



cylinder 306 so that the float 304 is able to slide up and down on the sealed cylinder 306 as the beverage level within the first reservoir 112 rises and falls. A follower 308 positioned within the sealed cylinder 306 is magnetically attracted to the float 304 so that the follower 308 moves up and down with the float 304 to actuate the fluid level switch 302.

Referring back to FIG. 1, the fluid switch power line 300 extends from the fluid level switch 302 to a relay 310 that actuates the power switch 274. The relay 310 is preferably constantly connected to the power switch power line 272 so that the relay 310 receives power from the power supply 270 when the fluid level switch 302 is closed. Preferably, if the fluid level switch 302 is closed, indicating the fluid level within the first reservoir 112 is sufficiently high, and then the relay 310 switches the power switch 274 to connect the power switch power line 272 to the pressure switch power line 275. If the fluid level switch 302 is open, then the relay 310 switches the power switch 274 to connect the power switch power line 272 to the indicator power line 276, rather than the pressure switch power line 275.

Thus, the power supply 270 will begin to supply power to activate the pump 114 if: (1) the pressure switch 280 is closed, indicating the pressure of the beverage within the second reservoir 116 is below the operating pressure range, which in turn indicates that the quantity of beverage within the second reservoir 116 is below an operating range; and (2) the fluid level switch 302 is closed, indicating the first reservoir 112 contains sufficient beverage to be supplied by the pump 114 to the second reservoir 116. The power supply 270 will cease supplying power to deactivate the pump 114 if either: (1) the pressure switch 280 opens, indicating the pressure of the beverage within the second reservoir 116 is above the operating pressure range; or (2) the fluid level switch 302 opens, indicating that the beverage level within the first reservoir 112 is not sufficiently high to continue supplying beverage to the second reservoir 116.

In operation, the bottle 108 is placed in the inverted position shown in FIGS. 2-5. Referring to FIG. 1, at that time, beverage will fill the first reservoir 112, as discussed above. This filled status is indicated to the relay 310 by the fluid level switch 302 as described above, and the relay will switch the power switch 274 to connect the power switch power line 272 to the pressure switch power line 275. The second reservoir 116 may initially contain no beverage, so that the gas within the gas

chamber **258** presses the barrier **254** against the sides and bottom of the tank so that the beverage chamber **256** has substantially no volume as shown in **FIG. 6**. In this state where the second reservoir **116** has no beverage or if its beverage level is low then its pressure is also low. This low beverage quantity and pressure status is

5 indicated by the pressure switch **280** closing, and thereby connecting the pump **114** to the power switch power line **272** via the pressure switch power line **275** and the power switch **274**. The pump **114** is thereby operated to pump beverage from the first reservoir **112** to the beverage chamber **256** of the second reservoir **116**. As the pump **114** increases the quantity of beverage in the beverage chamber **256**, the

10 pressure in the beverage chamber **256** also increases. The pressure of the beverage presses against and displaces the barrier **254** so that the beverage chamber **256** expands to accommodate the increasing quantity of beverage as shown in **FIGS. 7-8**. The pump **114** continues pumping beverage from the first reservoir **112** to the beverage chamber **256** of the second reservoir **116** until the pressure within the

15 beverage chamber rises above the operating pressure range. At that point, the pressure switch **280** opens, thereby disconnecting the pump **114** from the power switch power line **272** and deactivating the pump.

Because the dispenser **118** is connected to the pressurized beverage chamber **256**, pressurized beverage is supplied to the dispenser **118**. The beverage may be

20 automatically or manually dispensed from the dispenser **118** by opening the dispenser valve **266**. As the beverage is dispensed from the dispenser **118**, the quantity of beverage within the beverage chamber **256** decreases. The pressure within the beverage chamber **256** also decreases and the barrier **254** contracts the beverage chamber **256**. This contraction may continue during several uses of the

25 dispenser **118** without the pump **114** being operated. Thus, users of the dispenser **118** are not annoyed by the constant noise of the pump **114** as they use the dispenser **118**, making use of the dispenser **118** a more pleasant experience.

When the pressure within the beverage chamber **256** of the second reservoir **116** drops below the operating range, then the pressure switch **280** closes again.

30 This will again operate the pump **114** so long as sufficient beverage remains within the first reservoir **112** as indicated by the fluid level switch **302** being closed. This cycle of beverage being supplied from the expandable beverage chamber **256** and the pump **114** operating periodically to supply beverage to the beverage chamber

256 continues so long as the first reservoir 112 contains sufficient beverage. When the beverage supply system 100 has emptied the bottle 108, the bottle will, of course, no longer supply beverage to the first reservoir 112, and the beverage level of the first reservoir 112 will drop until the first reservoir no longer contains  
5 sufficient beverage to be pumped to the beverage chamber 256 of the second reservoir. At that time, the float 304 of the fluid level switch 302 will also drop, and the fluid level switch 302 will open. The relay 310 will then switch the power switch 274 from the pressure switch power line 275 to the indicator power line 276. With the pressure switch power line 275 disconnected from the power switch power  
10 line 272, the pump 114 can no longer be operated, even if the pressure switch 280 is closed. With the indicator power line 276 connected to the power switch power line 272, the indicator light 282 will remain on so long as the fluid level within the first reservoir 112 remains low. The indicator light 282 thereby indicates that the bottle 108 is empty and needs to be replaced with a new bottle. When the bottle 108 is  
15 replaced, then operation of the beverage supply system 100 continues as described above.

If the beverage supply system 100 needs to be disconnected from the dispenser 118, the bottle 108 can be removed. The beverage within the system 100 can then be drained by simply opening the dispenser valve 266. The dispenser 118  
20 can then be disconnected. Alternatively, a valve could be included on the dispenser supply line 260. This valve could be closed before disconnecting the dispenser 118.

An alternative embodiment 400 of the beverage supply system in accordance with the present invention is shown in FIGS. 9, 10 and 11. A schematic diagram is shown in FIG. 10. A sectional view is shown in FIG. 9, and a perspective view of  
25 the system 400 is shown in FIG. 11. In this alternative embodiment, the system 400 is designed to accommodate an external source of beverage supply in addition to a bottle supply as in beverage supply system 100. The components and operation of the system 400 are the same as in system 100 described in detail above except for the addition of a provision for connection of the system to a feed from an external  
30 source, such as a reverse osmosis water purification system (not shown) through a port 402 that passes through the wall 132 to a line 404 which connects to a tee fitting 406 in the feed line 232 to the pump 114, and the provision of a switch contact 412 to bypass the float switch 302 as described below.

In FIGS. 9, 10, and 11, the same numbering of components is utilized as in the first embodiment 100 described above except for the additional components added. In particular, a valve 408 is placed between the outlet fitting 216 and the tee 406 in the line 232. This valve 408 remains open whenever the system 400 is  
5 operated as described with reference to system 100. This valve 408 is preferably a solenoid valve, with a hand switch operator handle 409 on the outside of the cabinet, as is shown in FIG. 11, although it may alternatively be a manual valve as well. In this alternative embodiment 400, the bottle water source preferably may be utilized only if the external system is unavailable. This might be desirable, for example, in a  
10 commercial environment or a home environment where the water needs are greater than can be economically handled with single bottles. In such situations, a reverse osmosis water purification system might be in place. The output of this external system is provided as an input to system 400 via port 402. Beverage passes through the port 402, through line 404, tee 406, and into the pump 114 as needed. Should  
15 the external system be taken off line for any reason, a water bottle 108 would be installed, solenoid valve 408 opened via switch 409, and the system 400 operated as above described with reference to system 100. A solenoid stop/check valve 410 in the feed line 404 prevents backflow of bottle water through the port 402 into the external system. In actual operation, the external system may predominate in  
20 supplying the beverage to the pump 114, while a bottle 108 is installed and simply provides either an automatic backup source for the system 400 if valve 408 is chosen appropriately as a solenoid operated stop/check valve, or manual backup source for the system 400 if valve 408 is a hand valve.

In the case where a bottle 108 is not installed in the first reservoir 112 during  
25 normal operation, a circular cap would be installed over the opening into reservoir 112 that engages the annular ridge 190 in the top wall 182. When it is desired to install a bottle 108, the cap would simply be removed and stored inside the housing of the system 400.

Referring now to FIG. 10, a perspective view is shown. Note that valve 408  
30 has a handle 409 protruding through the cabinet front. This handle is the solenoid operator for valve 408. In operation, the valve 408 not only closes off the first reservoir 112 while the external system is supplying beverage to the second reservoir through the pump 114, the control for this valve, the handle 409 on the

front of the unit, has a switch contact 412 that bypasses the float switch 302 so that when a bottle 108 is not installed, the pump 114 will continue to operate as previously described to provide beverage through the external supply to the second chamber 256 being maintained within the desired pressure range.

5           It will be clear that the present invention is well adapted to attain the ends and advantages mentioned as well as those inherent therein. While a presently preferred embodiment has been described for purposes of this disclosure, various changes and modifications may be made which are well within the scope of the present invention.

10           For example, the second reservoir could operate without a solid barrier by having the second reservoir contain a compressed gas that is further compressed by the beverage itself as the second reservoir is filled. Also, the electrical components could be configured in many different ways. In alternative embodiment 400, the valve 408 shown in Figure 10 may be simply replaced with a check valve and a  
15           simple switch provided on the side of the enclosure to bypass the float switch 302 when an external source is operational or engage the float switch 302 when a bottle 108 is installed. Alternatively, the switch contact 412 may be omitted if the valve 408 is closed during external source use and a bottle 108 is installed on the first reservoir 112. The check valves in the system could be replaced with stop/check  
20           valves to ensure isolation capability in case of leaks or other malfunctions, as well as support automatic operation of the system 400 with either bottle or external supply. The placement of the port 402 may be other than the wall 132. It may be located in any location that is convenient for the connection to the reverse osmosis system. The placement of the handle or switch 409 for valve 408 may be other than on the  
25           side 132. This valve actuator may be internal to the enclosure rather than having a handle placed as shown in FIG. 11. Numerous other changes may be made which will readily suggest themselves to those skilled in the art and which are encompassed in the spirit of the invention disclosed and as defined in the appended claims.

### Claims

What is claimed is:

- 5           1. A beverage supply system comprising:  
a beverage container having a bottom outlet;  
a first reservoir connected to the beverage container bottom outlet to receive  
beverage from the beverage container under force of gravity;  
a pump connected to the first reservoir;  
10           a second reservoir connected to the pump, the second reservoir defining an  
expandable beverage chamber, receiving beverage pumped from the first reservoir  
only when a first quantity of beverage in the first reservoir is within a first quantity  
range and a second quantity of beverage in the second reservoir is below a second  
quantity range; and  
15           an external supply port connected between the first reservoir and the pump.
2. The supply system of claim 1, wherein the pump is deactivated if either  
the first quantity of beverage in the first reservoir is below the first quantity range or  
the second quantity of beverage in the second reservoir is above the second quantity  
20 range.
3. The supply system of claim 1, wherein the second reservoir comprises a  
tank containing the second quantity of beverage in the second reservoir and a solid  
barrier within the tank that presses against the second quantity of beverage in the  
25 second reservoir, the barrier and the tank defining the beverage chamber.
4. The supply system of claim 3, wherein the second quantity of beverage  
displaces the barrier as the second quantity of beverage in the second reservoir  
increases.  
30
5. The supply system of claim 4, wherein the barrier is a flexible diaphragm  
within the tank.

6. The supply system of claim 3, wherein the barrier increases a pressure within the beverage chamber in the second reservoir as the second quantity of beverage in the second reservoir increases.

5           7. The supply system of claim 6, further comprising a pressure switch responsive to the pressure within the beverage chamber and operative to deactivate the pump when the second quantity of beverage is above the second quantity range.

10           8. The supply system of claim 7, further comprising a fluid level switch within the first reservoir, the fluid level switch operative in response to a beverage level in the first reservoir.

15           9. The supply system of claim 1, wherein the pump, the first reservoir, and the second reservoir are positioned in an enclosed space defined by a housing that supports the beverage container.

          10. The supply system of claim 9, wherein the housing comprises a unitary member.

20           11. The supply system of claim 10, wherein the unitary member comprises a polymer material.

25           12. The supply system of claim 11, wherein the housing includes a door selectively providing access to the enclosed space, the door comprising the polymer material.

30           13. The supply system of claim 1, further including an indicator light that indicates when the first quantity of beverage within the first reservoir is below the first quantity range.

          14. A beverage supply system comprising:  
          a first reservoir adapted to receive beverage from a beverage container under force of gravity;

a pump connected to the first reservoir;  
an external port connected to the pump for supplying beverage to the pump;  
and

a second reservoir connected to the pump, the second reservoir comprising a  
5 solid barrier adapted to press against a second quantity of beverage within the  
second reservoir as the second quantity of beverage within the second reservoir  
displaces the barrier to produce a pressure within the second quantity of beverage  
within the second reservoir; and

10 wherein the second reservoir is adapted to supply beverage to a beverage  
dispenser without the pump being operated; and

wherein the pump is activated to pump beverage either from the first  
reservoir to the second reservoir when a first quantity of beverage in the first  
reservoir is within a first quantity range and the second quantity of beverage in the  
second reservoir is below a second quantity range or from the external port if  
15 beverage is available through the external port.

15. The supply system of claim 14, wherein the pump is deactivated if either  
the first quantity of beverage in the first reservoir is below the first quantity range or  
the second quantity of beverage in the second reservoir is above the second quantity  
20 range when beverage is unavailable through the external port.

16. The supply system of claim 14, wherein the second reservoir comprises  
a tank and the barrier is secured within the tank.

25 17. The supply system of claim 16, wherein the barrier is a flexible  
diaphragm.

18. The supply system of claim 17, wherein the barrier increases the  
pressure within the second quantity of beverage in the second reservoir as the second  
30 quantity of beverage in the second reservoir increases.

19. The supply system of claim 18, further comprising a pressure switch  
responsive to the pressure within the second quantity of beverage in the second



reservoir and operative to deactivate the pump when the second quantity of beverage in the second reservoir is above the second quantity range.

20. The supply system of claim 14, wherein the pump, the first reservoir,  
5 and the second reservoir are positioned in an enclosed space defined by a housing that supports the beverage container.

21. The supply system of claim 20, wherein the housing comprises a unitary  
10 polymer member defining the enclosed space and a door spanning an opening in the unitary polymer member.

22. The supply system of claim 14, further including an indicator light that  
15 indicates when the first quantity of beverage within the first reservoir is below the first quantity range.

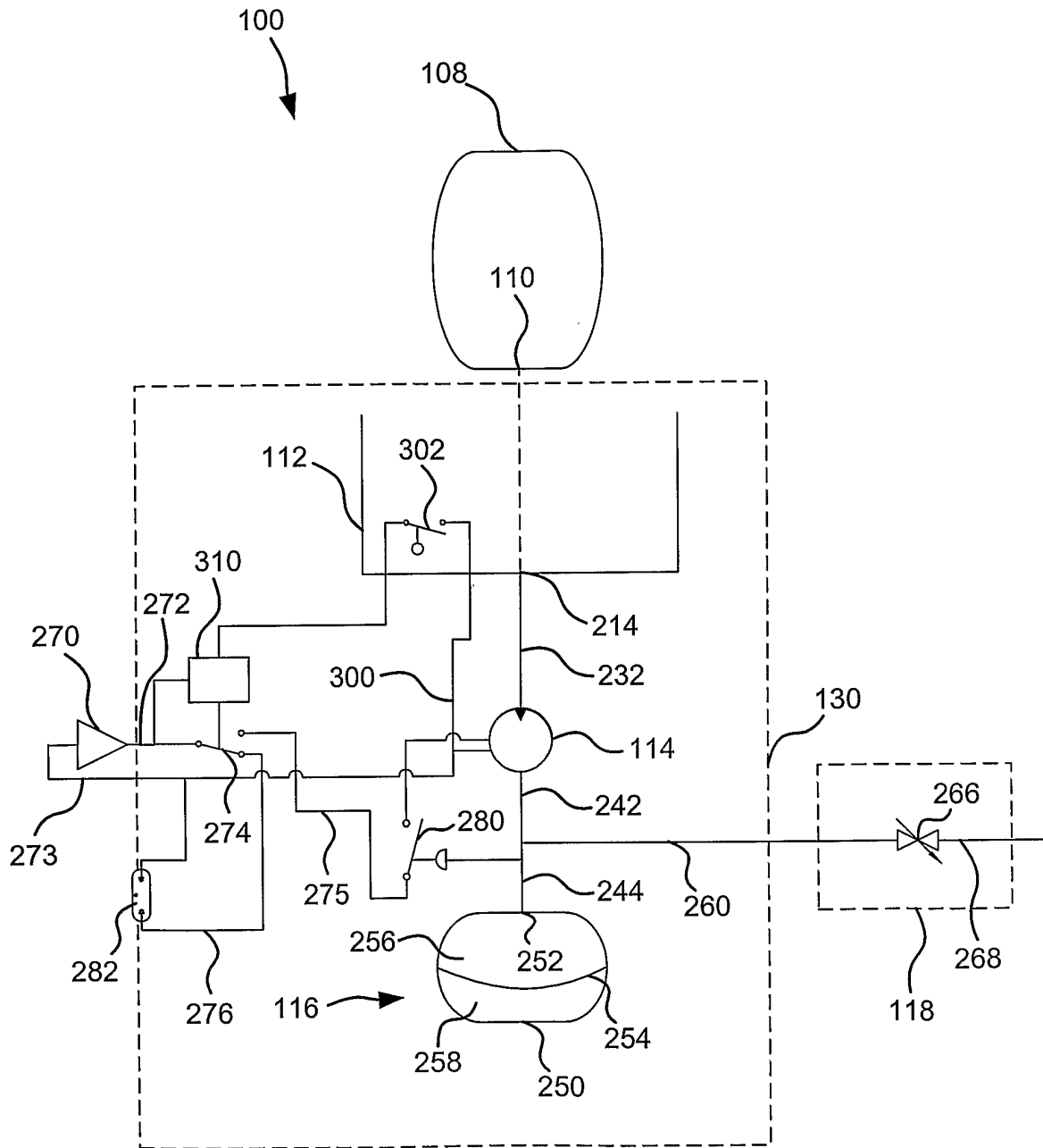

FIG. 1

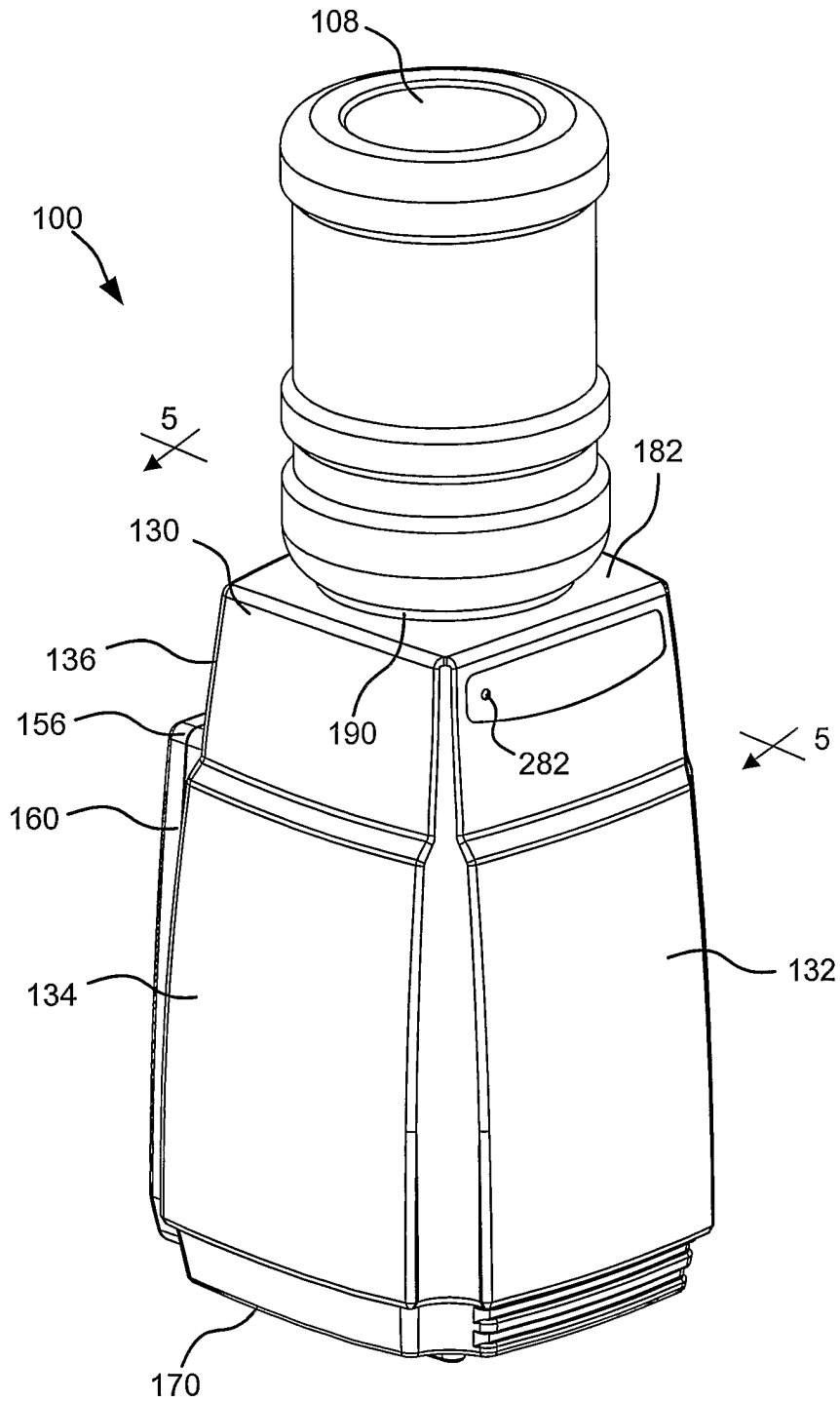

FIG. 2

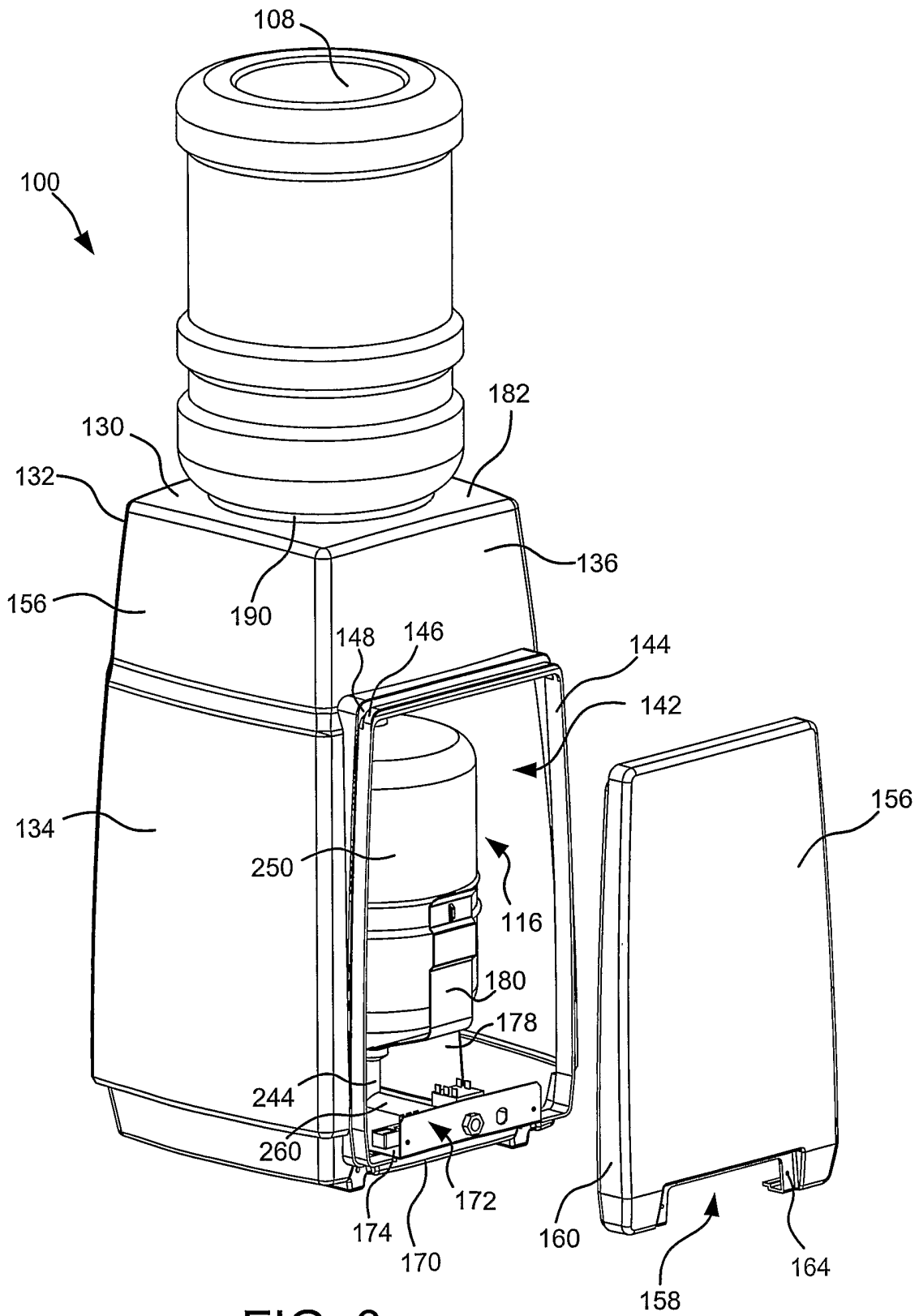

FIG. 3

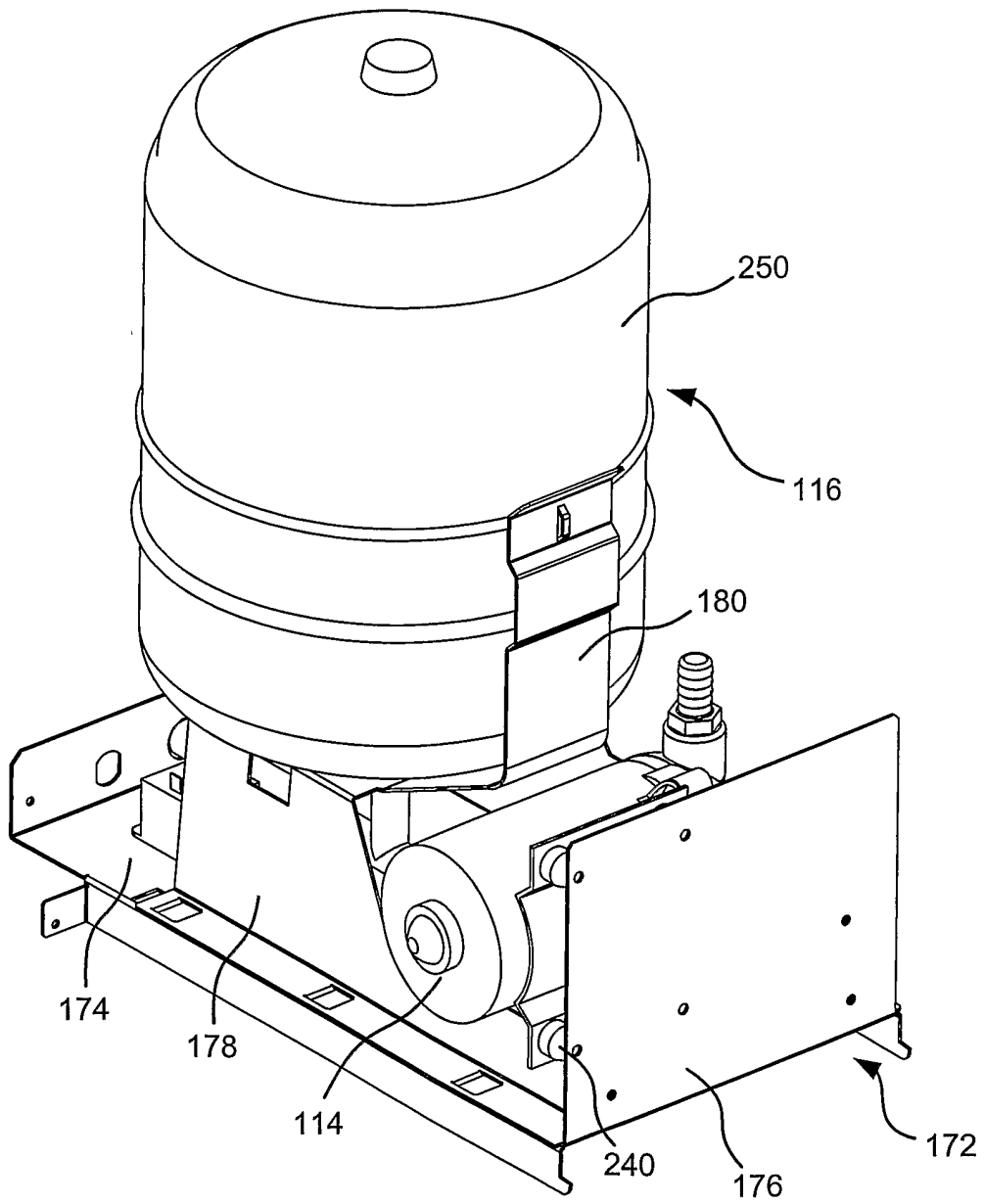

FIG. 4

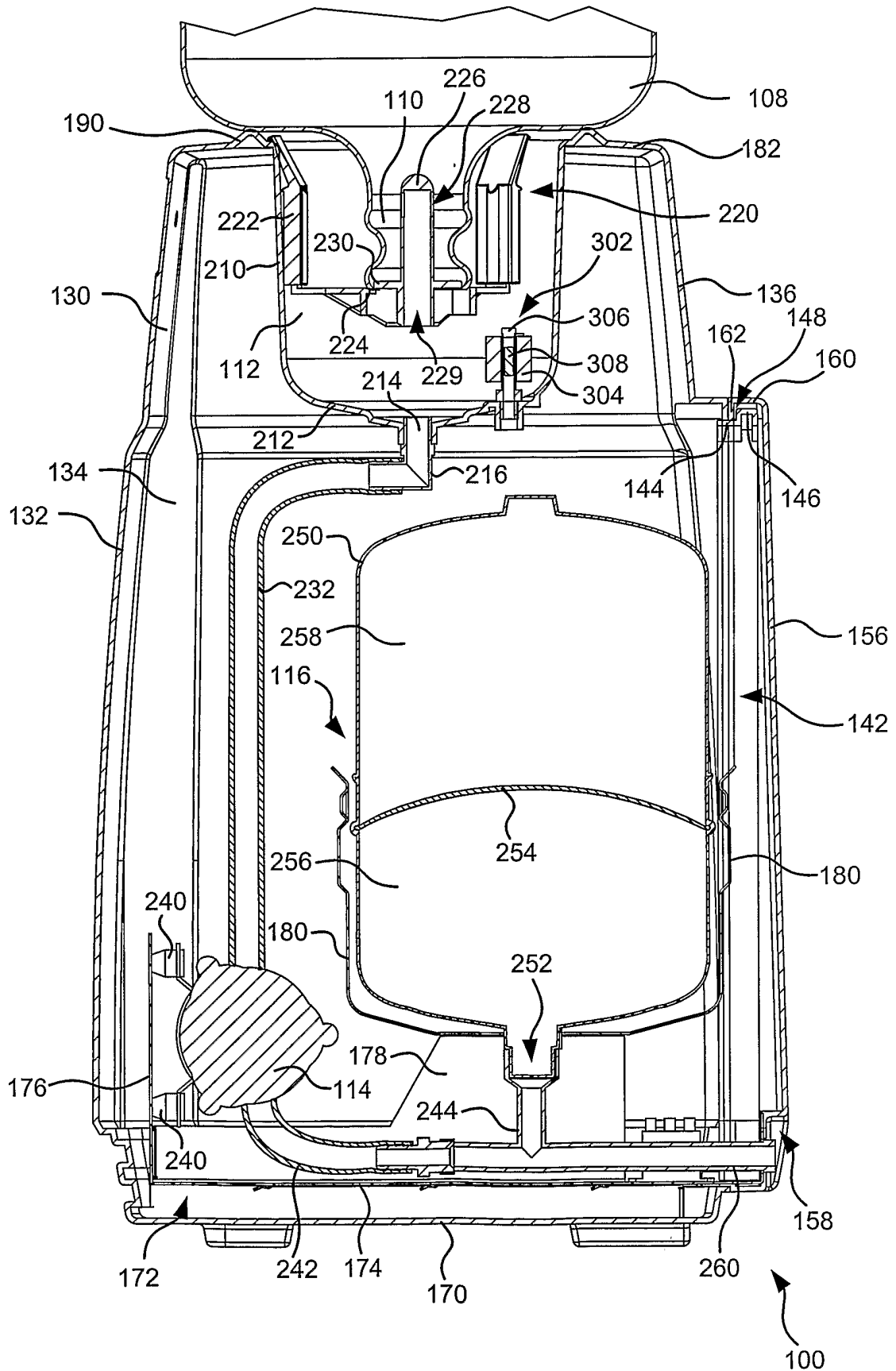
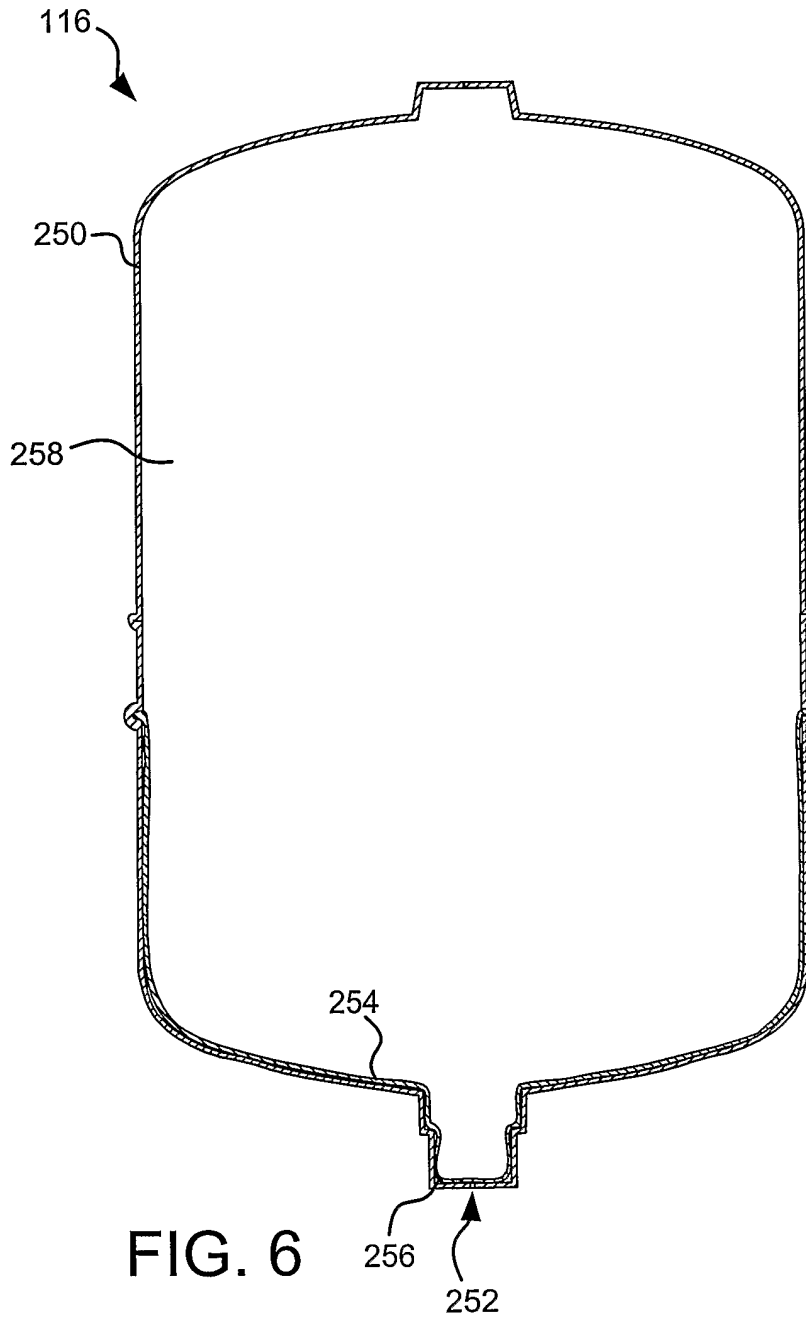

FIG. 5



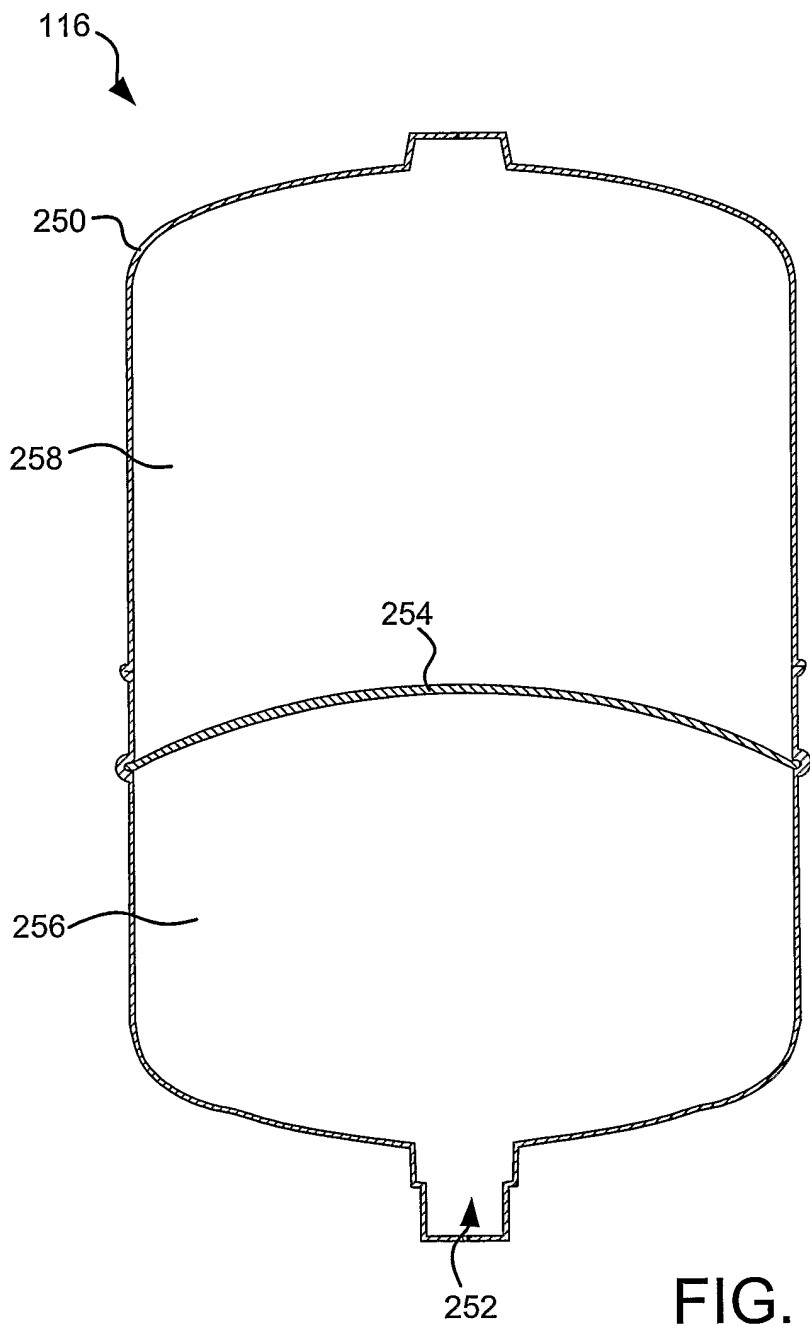

FIG. 7



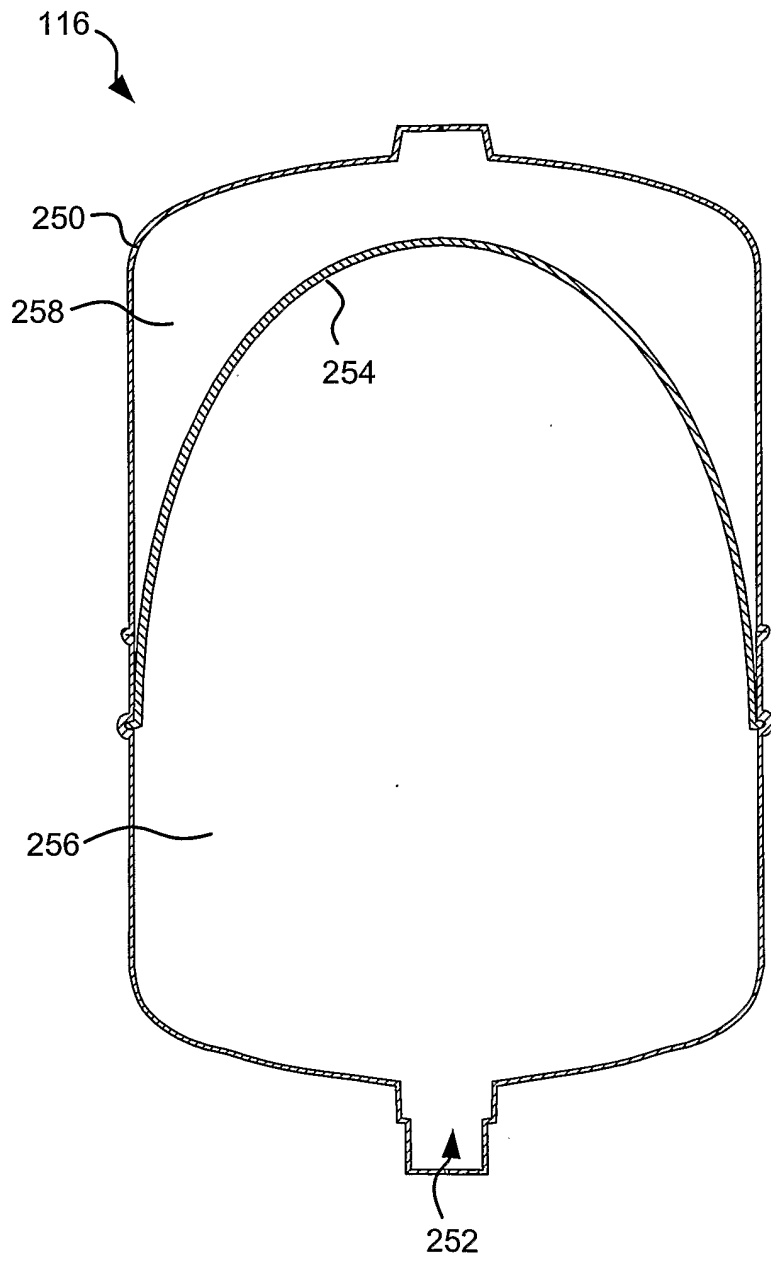

FIG. 8

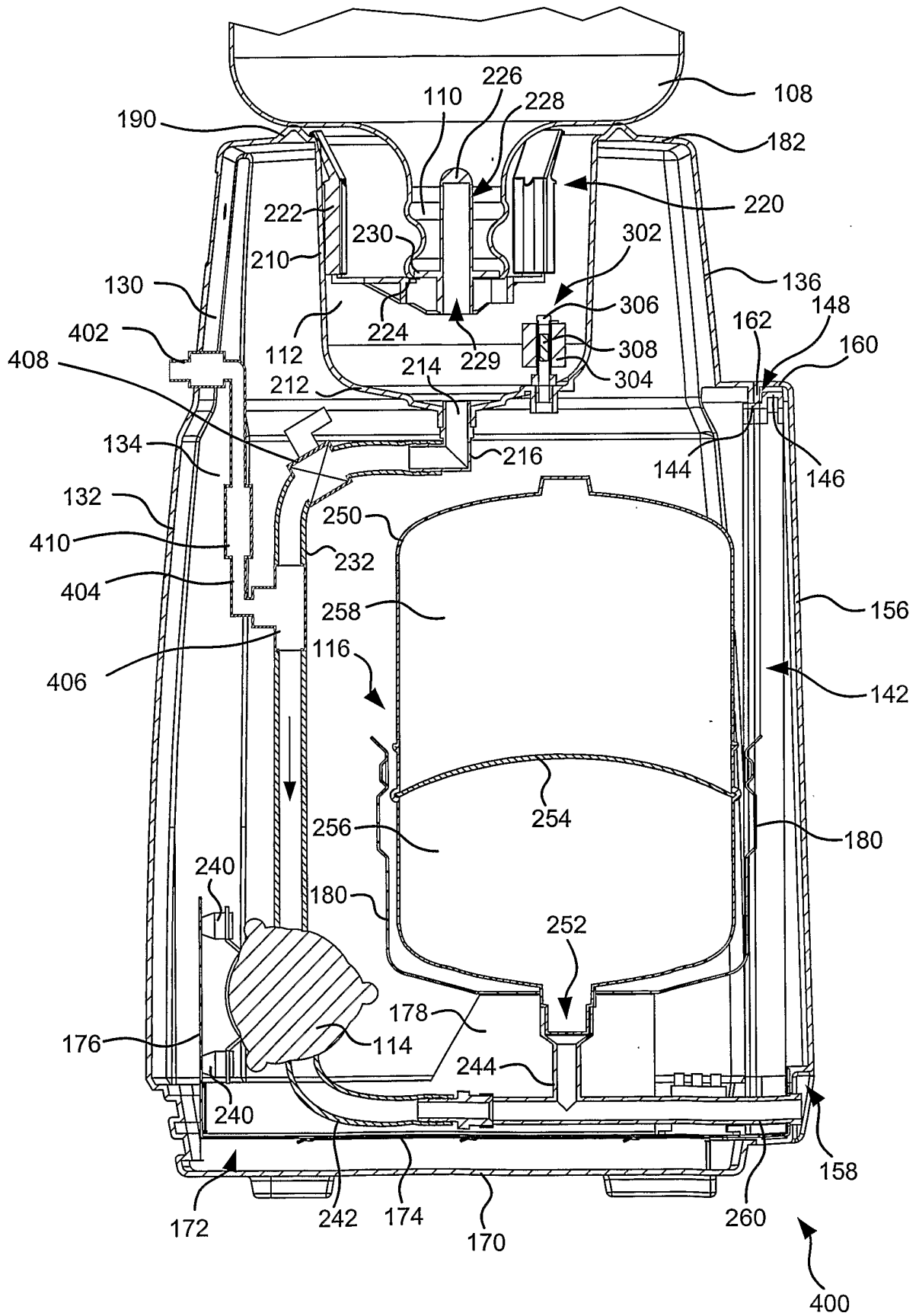

FIG. 9

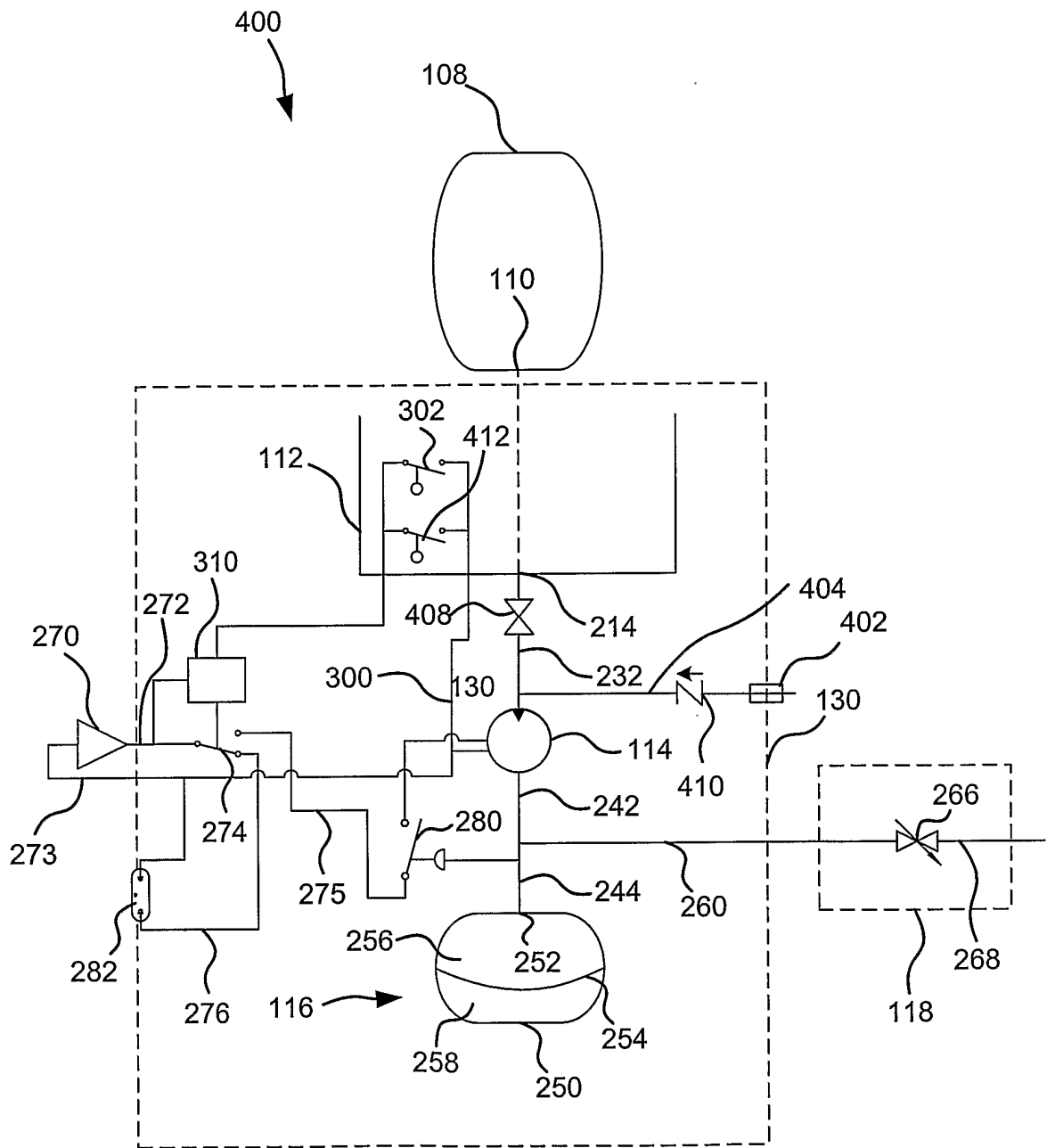

FIG. 10

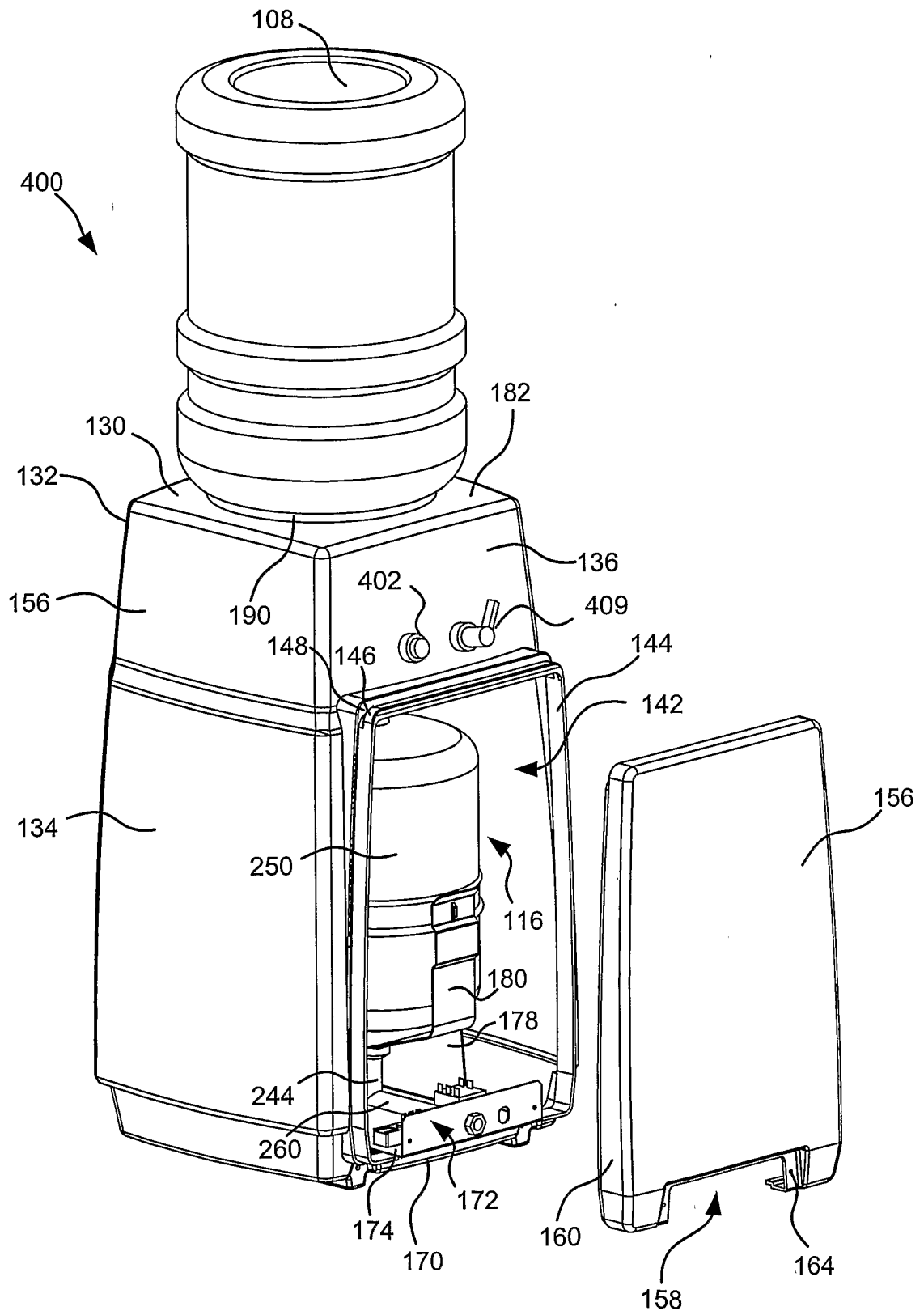

FIG. 11