

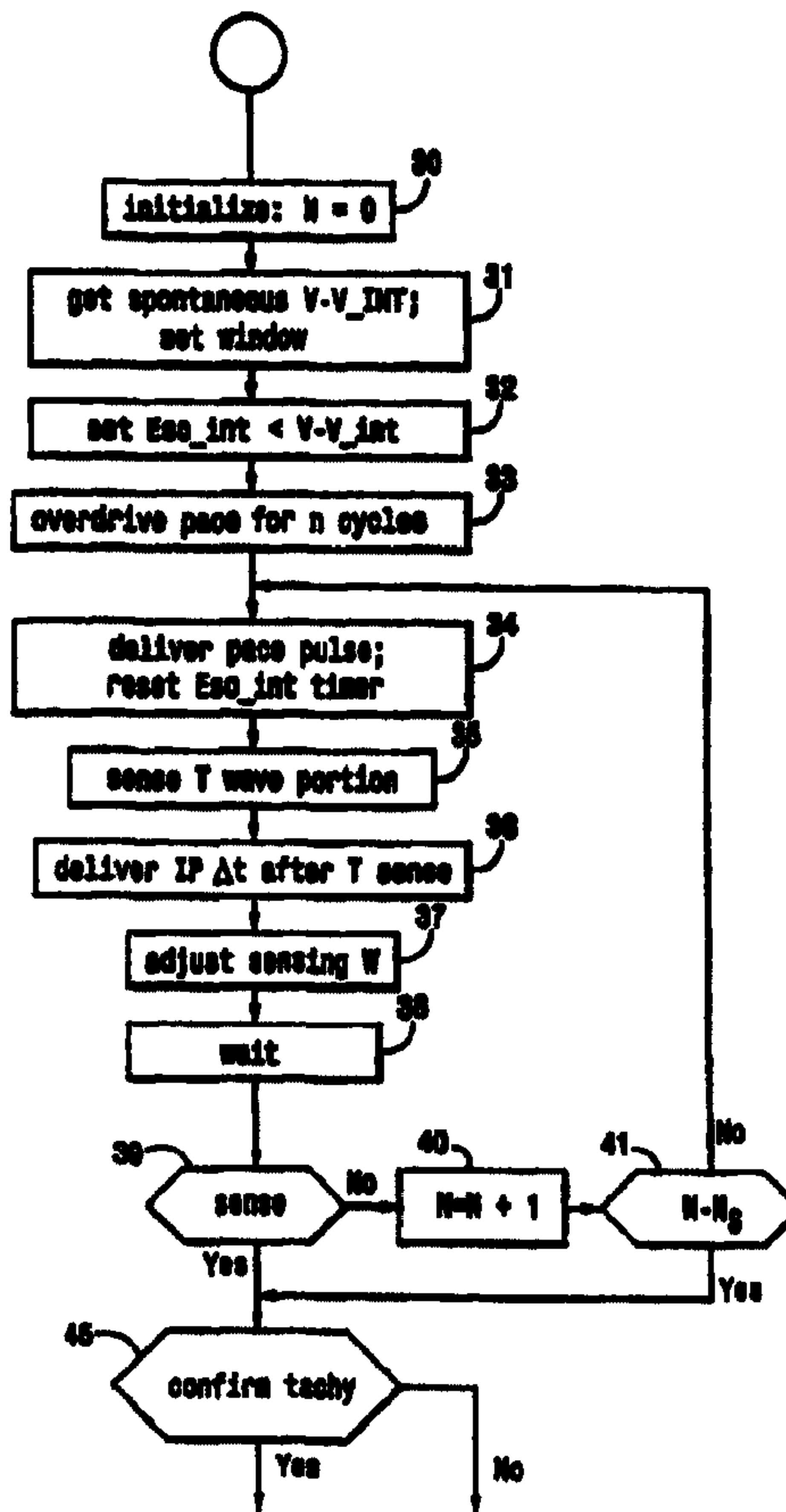

(86) Date de dépôt PCT/PCT Filing Date: 1999/01/26
 (87) Date publication PCT/PCT Publication Date: 1999/07/29
 (45) Date de délivrance/Issue Date: 2004/05/04
 (85) Entrée phase nationale/National Entry: 2000/07/20
 (86) N° demande PCT/PCT Application No.: EP 1999/000519
 (87) N° publication PCT/PCT Publication No.: 1999/037362
 (30) Priorités/Priorities: 1998/01/27 (09/014,378) US;
 1998/01/27 (09/014,178) US

(51) Cl.Int.⁶/Int.Cl.⁶ A61N 1/38
 (72) Inventeurs/Inventors:
 THOMPSON, DAVID L., US;
 WESTENDORP, HENDRIKUS A., NL;
 BEGEMANN, MALCOLM J.S., NL;
 DEN DULK, KAREL, NL;
 LEERSSEN, HENNY M., NL;
 ZEIJLEMAKER, VOLKERT A., NL
 (73) Propriétaire/Owner:
 VITATRON MEDICAL, B.V., NL
 (74) Agent: MCFADDEN, FINCHAM

(54) Titre : SYSTEME INDUCTEUR DE TACHYCARDIE RECOURANT A LA DETECTION DE L'ONDE T DE CHAMP PROCHE
 (54) Title: SYSTEM FOR INDUCING TACHYCARDIA UTILIZING NEAR FIELD T-WAVE SENSING



(57) Abrégé/Abstract:

A system and method are provided for inducing ventricular tachycardia in a patient to enable testing to determine the optimum parameters for anti-tachycardia stimulation. The implantable device provides for overdrive pacing of the heart for a short

(57) Abrégé(suite)/Abstract(continued):

sequence, followed by delivery of a series of pulse pairs. Each pulse pair has a first stimulus pulse delivered at the same or similar overdrive rate, and an inducing pulse which is delivered in timed relation to the evoked T-wave, preferably during the falling edge portion of the T-wave. In this way, each cycle the inducing pulse is timed for efficaciously inducing tachycardia. The timing of the inducing pulse is enhanced by near field sensing of the T-wave at about the location where the pulses are delivered, preferably using bipolar sensing and/or sense circuitry designed to recover the signal with an optimum time response. In one preferred embodiment, near field sensing is enabled by use of an FDC circuit. In another preferred embodiment, near field sensing is provided by a pacing lead having bipolar electrodes where the ring electrode is spaced less than 1 mm proximal to the tip electrode.

PCT

WORLD INTELLECTUAL PROPERTY ORGANIZATION
International Bureau

INTERNATIONAL APPLICATION PUBLISHED UNDER THE PATENT COOPERATION TREATY (PCT)

(51) International Patent Classification ⁶ : A61N 1/38	A1	(11) International Publication Number: WO 99/37362 (43) International Publication Date: 29 July 1999 (29.07.99)
(21) International Application Number: PCT/EP99/00519 (22) International Filing Date: 26 January 1999 (26.01.99) (30) Priority Data: 09/014,178 27 January 1998 (27.01.98) US 09/014,378 27 January 1998 (27.01.98) US (71) Applicant: VITATRON MEDICAL, B.V. [NL/NL]; Kanaalweg 24, NL-6951 AB Dieren (NL). (72) Inventors: THOMPSON, David, L.; 1660 Onandaga Street N.E., Fridley, MN 55432 (US). WESTENDORP, Hendrikus, A.; Braamkamp 385, NL-7206 HT Zutphen (NL). BEGEMANN, Malcolm, J., S.; Biesdelselaan 12A, NL-6881 CG Velp (NL). DEN DULK, Karel; Lantaarnstraat 9-D, NL-6211 KX Maastricht (NL). LEERSSEN, Henny, M.; Eikenhoven 11, NL-6225 GV Maastricht (NL). ZEIJLEMAKER, Volkert, A.; Wachtendonckstraat 22, NL-6371 VW Landgraaf (NL). (74) Agent: EBBINGHAUS, D.; Von Föner Ebbinghaus Finck, Postfach 95 01 60, D-81517 München (DE).	(81) Designated States: CA, JP, European patent (AT, BE, CH, CY, DE, DK, ES, FI, FR, GB, GR, IE, IT, LU, MC, NL, PT, SE). Published <i>With international search report.</i> <i>Before the expiration of the time limit for amending the claims and to be republished in the event of the receipt of amendments.</i>	

(54) Title: SYSTEM FOR INDUCING TACHYCARDIA UTILIZING NEAR FIELD T-WAVE SENSING**(57) Abstract**

A system and method are provided for inducing ventricular tachycardia in a patient to enable testing to determine the optimum parameters for anti-tachycardia stimulation. The implantable device provides for overdrive pacing of the heart for a short sequence, followed by delivery of a series of pulse pairs. Each pulse pair has a first stimulus pulse delivered at the same or similar overdrive rate, and an inducing pulse which is delivered in timed relation to the evoked T-wave, preferably during the falling edge portion of the T-wave. In this way, each cycle the inducing pulse is timed for efficaciously inducing tachycardia. The timing of the inducing pulse is enhanced by near field sensing of the T-wave at about the location where the pulses are delivered, preferably using bipolar sensing and/or sense circuitry designed to recover the signal with an optimum time response. In one preferred embodiment, near field sensing is enabled by use of an FDC circuit. In another preferred embodiment, near field sensing is provided by a pacing lead having bipolar electrodes where the ring electrode is spaced less than 1 mm proximal to the tip electrode.

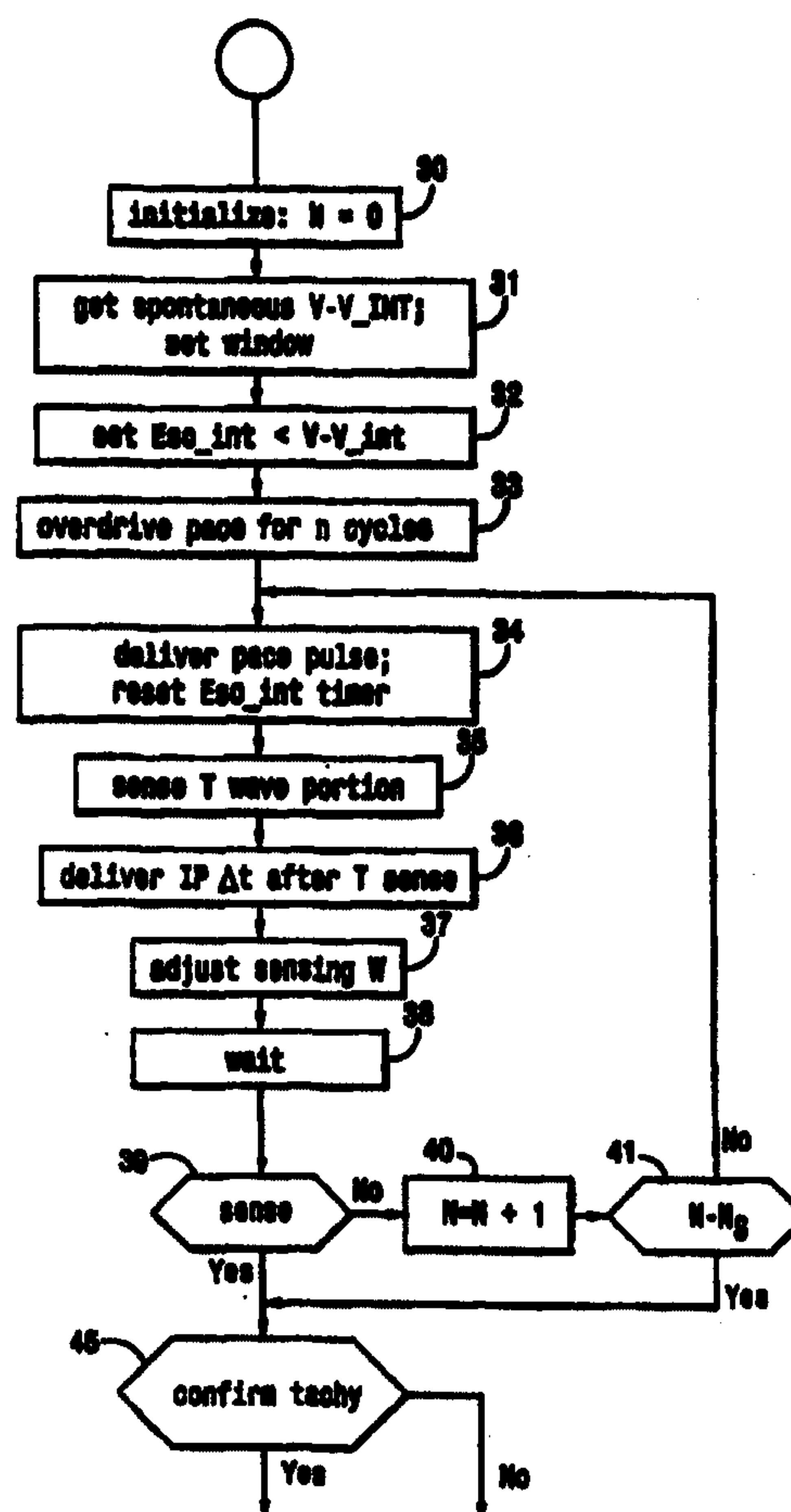

**SYSTEM FOR INDUCING TACHYCARDIA
UTILIZING NEAR FIELD T-WAVE SENSING**

5 This invention relates to cardiac stimulus systems which have a
cardioversion capacity and, more particularly, to such cardiac systems which have the
further capability of inducing ventricular tachycardia or fibrillation in a patient so that
cardioversion parameters can be tested and set.

BACKGROUND OF THE INVENTION

10 The treatment of abnormally and physiologically dangerous high
cardiac rate conditions, i.e., tachycardia and fibrillation, has become very important,
and is the subject of considerable development. For example, modern implantable
cardiac pacemakers can be provided with an anti-tachycardia feature, whereby the
implantable device senses the occurrence of tachycardia, and responds by delivering
one or more stimuli in a pattern designed to eliminate the dangerous high rate.
15 Likewise, implantable defibrillators are designed to determine the occurrence of
fibrillation, and to respond automatically with one or more defibrillation pulses. In
this specification, the reference to abnormally high rates, or high rate conditions,
incorporates the range of abnormal conditions, through all tachycardia rates up to and
including fibrillation. Thus, the term tachycardia as used herein embraces the range of
20 abnormally high rates, up to and including fibrillation. The treatment of such
conditions, i.e., anti-tachycardia treatment or defibrillation, is referred to generally as
cardioversion. The devices which can provide such cardioversion treatment can be
specifically designed for a given treatment, i.e., defibrillators, or can be devices
which combine pacing functions and one or more types of cardioversion treatment.

25 When implanting such an implantable device which provides for
cardioversion, it is necessary to test the device operationally, and set the stimulus
parameters so as to ensure reliable treatment. Thus, for a pacemaker having a feature
of terminating ventricular tachycardia (VT), it is important to test at time of implant to
determine that the prescribed pattern of anti-tachycardia stimulus pulses is delivered
30 with the optimal parameters to control and terminate the VT for the patient receiving

the implant. In order to carry out such a test, it is necessary to first induce the VT (or other high rate condition), and then set the anti-tachycardia stimulus parameters, e.g., number of pulses, timing and energy, for optimal termination of the VT. The aim of this invention is to provide the device with an improved and more reliable capability of inducing such a high rate abnormal condition, for test purposes.

It is known that tachycardia or fibrillation can be stopped, or terminated by delivery of stimulus pulses which interfere with the re-entry loop mechanism. Thus, in terminating such a non-physiological condition, a stimulus pulse is delivered shortly after the cardiac refractory period, and before the next expected spontaneous beat. In U.S. Patent 4,390,021, there is disclosed the standard technique of delivering a pair of pulses, each timed with respect to the preceding QRS so as to fall within a "region of susceptibility," in order to break up the tachycardia. The system of the disclosure relies on searching to find the timing which results in break up of tachycardia, i.e., to find the "region of susceptibility." It is mentioned that a similar technique can be used to induce tachycardia, but no specifics are mentioned with regard to the required timing. It is noted that the timing for inducing tachycardia is not necessarily the same, relative to the QRS, as for breaking up tachycardia.

U.S. Patent No. 4,593,695 discloses a successful technique for terminating VT which involves overdriving the ventricle with an early stimulus pulse, detecting the occurrence of the repolarization which is manifested by the T-wave, and then delivering a stimulus which is intended to break up the tachycardia. Since the T-wave is produced by cardiac cell repolarization and thus roughly indicates the end of the refractory period, it is necessary to wait until the T-wave detection in order to deliver a stimulus which can have an effect. Successive such early pulses can be delivered, as necessary to terminate the tachycardia condition. However, this reference gives no guidance concerning inducing tachycardia.

U.S. Patent No. 5,129,392 is specifically directed to a technique of inducing fibrillation by delivery of a high voltage pulse following the refractory period of the heart chamber. The refractory period is disclosed to be determined by getting an average of the stimulus-T interval and delivering the high voltage pulse at a

time based on this average and referenced to a preceding pacing pulse or spontaneous QRS. However, this technique has only about a 60% success rate, which means that often the delivery of a high energy pulse must be repeated. This produces substantial patient discomfort, and causes battery drain and consequent reduction of device longevity. Further, it is our observation that the timing with respect to the T-wave is critical, and accordingly it is desirable to do more than simply deliver an inducing pulse after the some predetermined interval following the QRS or the T-wave.

For an implantable device having an anti-tachycardia feature, it is desirable to be able to induce tachycardia using the vastly lower energy pacing pulses. This is the case whether the device is a pacemaker, or whether it incorporates cardioverting capacity, as with a combined pacemaker-cardioverter-defibrillator ("PCD"). In any case, it is highly desirable to provide the capability of inducing tachycardia by using only pacing-level pulses, to optimize patient comfort and save energy. This means that the tachy-inducing pulses are delivered as a series of smaller energy pulses. Since QT interval varies with rate, the delivery of the first inducing pulse likely has an effect on the following QT interval. The result of delivering a series of pulses is that each cycle the refractory interval may be slightly different, such that use of a fixed interval following the pacing stimulus or sensed QRS is relatively unlikely to be efficient in finding the proper time to induce VT. Accordingly, it is important to be able to determine on a cycle-to-cycle basis the best time to deliver the inducing pulse (or pulse pair). The solution provided by this invention is to look for the occurrence of a T-wave following a QRS which preferably is evoked by a pacing pulse; to determined the T-wave by near field sensing at the location where the pacing pulses are delivered; and to deliver one or more inducing pulses in closely timed relation to a specific portion of the sensed T-wave.

SUMMARY OF THE INVENTION

It is a feature of one embodiment of this invention, in an implantable cardiac stimulating device which includes a feature for breaking up a sensed tachycardia and a feature for inducing such tachycardia, to provide low energy pacing pulses in timed relation to the T-wave portion of ventricular signals evoked by prior pacing pulses, and to accurately detect the T-wave portion with near field sensing of the repolarization at the location where pacing pulses are delivered to the cardiac wall.

The feature of providing a tachycardia-inducing capability is achieved by accurate sensing of a predetermined portion or feature of the T-wave, and delivery of an inducing stimulus pulse to the patient's ventricle directly upon sensing of the T-wave portion. Preferably a series of pacing pulses is delivered at an overdrive rate, with a tachycardia inducing pulse delivered upon sensing of each T-wave which follows an evoked QRS. If an early QRS is sensed before delivery of a next scheduled overdrive pacing pulse, the inducing routine stops and looks for confirmation of tachycardia; if the entire series of pairs of pacing-level stimulus and inducing pulses is delivered, the device then looks for tachycardia, and if no tachycardia is confirmed, the inducing protocol can be repeated.

In the practice of this invention, it is desirable to deliver each inducing pulse while the repolarization signal, e.g., T-wave, is still on its negative, or downward slope, as measured in the area of heart tissue where the pulses are delivered. Consequently, the system of this invention preferably includes a sensing electrode configuration and/or sensing circuitry for optimizing near field sensing.

In accordance with one embodiment of the invention there is provided a system for inducing an abnormally high rate in a patient's heart, comprising: stimulus pulse

4a

means for generating and delivering a series of stimulus pulses at a predetermined rate to a heart chamber of the patient; sensing means for sensing a predetermined portion of each repolarization wave which follows each depolarization wave evoked by a stimulus pulse; and inducing means for triggering the stimulus pulse means to generate an inducing pulse following each sensed predetermined repolarization wave portion, the inducing means comprising timing means for timing each inducing pulse in a predetermined time relation to the repolarization wave portion, whereby a series of inducing pulses are delivered.

In accordance with a further embodiment of the invention there is provided an implantable pacing system, comprising: a pacing pulse generator for generating pacing pulses; a lead with at least one electrode for delivery of pacing pulses at a location of a predetermined one of the patient's heart chambers, the lead having a conductor for conducting the pacing pulses from the generator to the electrode; near field means electrically connected to the electrode for sensing repolarization waves from near the location and for determining the timing of a predetermined portion of each repolarization wave; and control means for controlling the timing of generation of pacing pulses by the generator, the control means having series means for controlling generation of a first series of pacing pulses for evoking heartbeats, and inducing means controlling generation of an inducing pacing pulse as a function of the timing of each repolarization portion evoked by a pacing pulse of said first series.

In accordance with another embodiment of the invention there is provided a system for inducing an abnormally high rate in a patient's ventricle, comprising: pacing pulse means for generating a series of pacing pulses at about a predetermined rate; lead means for delivering the pacing pulses to a location of the ventricle; near field means for obtaining near field T wave signals from near the location, and determining means for determining a falling edge portion of each near field T wave signal; and inducing means

4b

for triggering the pacing pulse means to generate an inducing pulse following each determined falling edge portion, the inducing means comprising timing means for timing an inducing pulse in a predetermined time relation to each near field T wave signal, whereby a series of inducing pulses are delivered to the patient's ventricle.

In accordance with yet another embodiment of the invention there is provided a system for inducing an abnormally high rate in a patient's ventricle, comprising: pacing pulse means for generating a series of pacing pulses at about a predetermined rate; lead means for delivering the pacing pulses to a location of the ventricle and for sensing cardiac signals, the lead means having a tip electrode for positioning at about the location and a ring electrode spaced proximally from the electrode by an inter-electrode distance of less than about 1 mm, whereby near field T wave signals are obtained between the electrodes; and inducing means for triggering the pacing pulse means to generate an inducing pulse following each obtained near field T wave signal, the inducing means comprising timing means for timing an inducing pulse in a predetermined time relation to each near field T wave signal, whereby a series of inducing pulses are delivered to the patient's ventricle.

In one preferred embodiment, atrial repolarization or near field T-wave sensing is provided by a field density clamp (FDC) circuit. In another embodiment, a lead is provided having closely spaced bipolar electrodes, e.g. separated by an interelectrode distance of less than 1 mm, for providing near field sensing. Digital signal processing is used to further enhance the sensed T-wave signal so as to provide a basis for accurate timing of the inducing pulse with respect to the repolarization.

BRIEF DESCRIPTION OF THE DRAWINGS

Fig. 1 is a functional block diagram of an implantable device representative of the devices in which the present invention is embodied; Fig. 1B illustrates a lead having electrodes adapted for unipolar or bipolar pacing and sensing, and also for delivering cardioverting pulses;

Fig. 2A is a timing diagram illustrating the sequence of overdrive pacing pulses and the timing of inducing pulses in accordance with this invention;

Fig. 2B is a timing diagram illustrating the preferred region of the T-wave which is sensed in order to best determine the timing of an tachycardia-inducing pulse in accordance with this invention;

Fig. 2C is a timing diagram illustrating the use of a sensing window for sensing the T-wave signal in accordance with this invention;

Fig. 3 is a flow diagram illustrating the primary steps taken in accordance with this invention for inducing tachycardia.

Fig. 4(a) is a block diagram illustrating the use of a field density clamp circuit with a unipolar lead, for sensing the T-wave; Fig. 4(b) is a block diagram illustrating the use of DSP sensing of a bipolar signal for obtaining the T-wave; Fig. 4(c) is a diagram of a lead having a bipolar electrode arrangement which is particularly adapted for good far field sensing; and Fig. 4(d) shows a surface EKG, and a corresponding intracardial ventricular signal obtained with the lead shown in Fig. 4(c).

DESCRIPTION OF THE PREFERRED EMBODIMENTS

Fig. 1 is a functional block diagram of an implantable pacemaker of the type in which the present invention may be practiced. The disclosed embodiment takes the form of a microprocessor controlled device. However, it is believed that the invention might usefully be practiced in other types of devices, including those employing dedicated digital circuitry, and perhaps even in devices comprised primarily of analog timing and control circuitry. As such, Fig. 1 should be considered exemplary, rather than limiting with regard to the scope of applications of the present invention. While the invention is disclosed as embodied in a pacemaker, it is equally

applicable to incorporation in a cardioverter, or combined cardioverter pacemaker, or even cardioverter defibrillator pacemaker. While the following discussion of Fig. 1 assumes a single chamber ventricular pacing system, it is to be understood that the invention is applicable to dual chamber systems.

5 The primary elements of the apparatus illustrated in Fig. 1 are microprocessor 100, read only memory 102, random access memory 104, a digital controller 106, input and output amplifiers 110 and 108 respectively, and a telemetry/programming unit 120.

10 Read only memory 102 stores the basic programming for the device, including the primary instructions set defining the computations performed to derive the various timing intervals performed by the device. Random access memory 104 serves to store the values of variable control parameters, such as programmed pacing rate, programmed cardioversion and defibrillation intervals, pulse widths, pulse amplitudes, and so forth, which are programmed into the device by the physician.

15 Random access memory also stores derived values, such as the interval defining the timing window for sensing T-waves, as discussed in connection with Fig. 2C. Reading from random access memory 104 and read only memory 102 is controlled by RD-line 146. Writing to random access memory 104 is controlled by WR-Line 148. In response to a signal on RD-Line 146, the contents of random access memory 104 or

20 read only memory 102 designated by the then present information on address bus 124 are placed on data bus 122. Similarly, in response to a signal on WR-line 148, information on data bus 122 is written into random access memory 104 at the address specified by the information on address bus 124.

25 Controller 106 performs all of the basic timing and control functions of the device. Controller 106 includes at least one programmable timing counter, initiated on ventricular contractions, paced or sensed, for timing out intervals thereafter. This timing counter is used to define the escape intervals for overdrive pacing, and the delay interval (if one is used) for timing the triggering of an inducing pulse following a sensed T-wave. It is also anticipated that the controller 106 would

30 also perform the basic timing functions of the pacing, and tachycardia detection

routines performed by the device, in accordance with well known techniques. Controller 106 also triggers output pulses from output stage 108 as discussed below, and it generates interrupts on control bus 132 for cyclically waking microprocessor 100 from its sleep state to allow it to perform the required functions. Output circuit 108 is coupled to electrodes 138 and 140 which are employed both for delivery of pacing pulses and for sensing of cardiac signals. Electrode 138 is typically located on the distal tip end of an endocardial lead and is typically placed in the apex of the right ventricle; for atrial mode pacing, of course, it is placed in the patient's atrium. Electrode 140 is preferably a ring electrode positioned at most a few mm from the tip electrode, for near field sensing. Electrode 142 represents the pacemaker housing, which may be used as the indifferent electrode for selected unipolar pacing and/or sensing operations, as discussed below. Output circuit 108 is controlled by controller 106 through bus 126 to determine the time, amplitude and pulse width of the pulse to be delivered and to determine which electrode pair will be employed to delivery the pulse. Output stage 108 also is used for delivery of the tachycardia-inducing pulses across electrodes 138, 140. In a PCD-type device, it may also be used for delivery of cardioverting pulses between electrodes 134 and can 142. Electrodes 134, 138 and 140 may suitably be provided by a lead such as shown in Fig. 1B, as provided by Medtronic lead Model 6932 (passive fixation) or Model 6936 (active fixation).

Sensing of QRS and T-waves is done by input amplifier circuitry 110, which receives sensed signals from electrodes 138, 140, and/or 142. Signals indicating the occurrences of natural ventricular contractions, and paced ventricular contractions as well as T-waves, are provided to the controller 106 via bus 128. Controller 106 passes data indicative of the occurrence of such ventricular signals to microprocessor 100 via control bus 132, for performance of all necessary calculations, and in particular for timing of the delivery of tachy-inducing pulses in the manner discussed below.

External control of the implanted device is accomplished via telemetry/control block 120, which allows communication between the implanted device and an external programmer, (not shown). Radio communication is typically

employed via antenna 144. Appropriate telemetry/programming systems are disclosed in U.S. Pat. No. 4,401,120, issued to Hartlaub et al., U.S. Pat. No. 4,556,063, issued to Thompson et al., and U.S. Pat. No. 4,550,370, issued to Baker. However, any conventional telemetry/programming circuitry is believed workable in the context of the present invention. Information entering the pacemaker from the programmer is passed to controller 106 via bus 130. Similarly, information from the pacemaker is provided to the telemetry block 120 via bus 130, for transmission to the external programmer.

10 Referring now to Fig. 2A, there is shown a timing diagram illustrating the manner of delivering inducing pulses for inducing tachycardia in accord with this invention. The timing diagram illustrates delivering pulses to the ventricle for inducing VT, but it is to be understood that the invention is also applicable to inducing atrial tachycardia.

15 Starting at the left of the timing diagram of Fig. 2A, there is shown a natural sinus beat existing in the patient, providing a $V-V_{int}$ which is measured by the pacemaker or other implantable device. Following measurement of the $V-V_{int}$, a series of n stimulus pulses are delivered at a rate which is greater than the natural rate, i.e., the escape interval is shorter than the $V-V_{int}$. After delivering n such
20 pulses, where n may be only one or two, or a greater number, a next pacing pulse is delivered at the same escape interval; following this an inducing pulse (designated IP) is delivered, preferably during the falling edge of the T-wave. As seen in Fig. 2B, the falling edge of the T-wave is defined as the downward slope following the maximum (peak) value of the T-wave. The inducing pulse can be delivered immediately, upon
25 detection of the negative-going falling edge, or it can be delivered after timeout of a small time delay (Δt) following the peak, where the delay is calculated to time out during the falling edge portion of the T-wave. As illustrated in Fig. 2A, two such inducing pulses are delivered, following which tachycardia occurs.

30 Referring to Fig. 2C, there is shown a timing diagram illustrating a time window W , which is used to time the operation of a T-wave sense amplifier in a

manner such as disclosed in U.S. Patent No. 4,593,695. The timing window is adjusted after each detected T-wave, such that it tracks the expected time of the T-wave following a delivered stimulus, thereby enabling the sensing amplifier to look for the T-wave falling edge during a specific limited interval each cycle.

Referring now to Fig. 3, there is illustrated a flow diagram representing the primary steps taken in carrying out the routine of this invention for inducing a high rate tachycardia. It is to be understood that the preferred embodiment involves a software routine carried out by the microprocessor 100 and memory 102 or 104, as illustrated in Fig. 1. However, this routine or other equivalent routines can be carried out by other equivalent logic components.

At block 30, the routine is initialized; the number n of initial overdrive pacing pulses is set to a predetermined value, and the number N_s of inducing pulses to be delivered in series is set, e.g., to a value within the range of 1-5, while variable N is set to 0. At 31, the device senses spontaneous heartbeats, and obtains the V-V interval. At 32, the escape interval is set equal to a value less than the V-V interval, so as to overdrive the natural rate. At 33, overdrive pacing pulses are delivered for n cycles, at the overdrive escape interval. Following this, as indicated at 34, a first pace pulse is delivered, again at the overdrive escape interval which has been set, and the escape interval timer is reset. At 35, the selected T-wave portion, preferably the falling edge, is detected. At 36, the inducing pulse is delivered at a predetermined time relative to the T sense. In a preferred embodiment, the inducing pulse is delivered directly upon detection of the falling edge of the T-wave, although the invention may be practiced by first timing out a short delay, Δt . After this, the T sense window W is adjusted as shown at 37, i.e., it is shifted forward/backward relative to the stimulus pulse, to track the T-wave. The device then waits, as illustrated at 38. If the waiting is ended by a sense at block 39, this indicates the occurrence of a spontaneous R wave before timeout of the next escape interval, which could indicate that tachycardia has been induced. The routine then branches to 45, and carries out a procedure for confirming tachycardia in accordance with conventional techniques. If,

following the wait at 38, there is not a sense at 39, but a timeout of the escape interval, the routine increments N by 1, as indicated at 40; if N is found to be equal to N_S at 41, this indicates the series has been completed, and the routine branches to 45. However, if N is not equal to N_S , the routine branches back to 34, and proceeds to deliver the next overdrive pace pulse and following inducing pulse. The routine thus controls the device to deliver a series of inducing pulses, each timed in relation to the T-wave following the last delivered stimulus pulse. If tachycardia is induced before the entire series is delivered, the series is terminated; if following the series, tachycardia has not been induced, a next series can be initiated by an appropriate command from the programmer.

As discussed above, the timing of each inducing pulse in the series of delivered inducing pulses is critical, and must be determined accurately with respect to each T-wave. Thus, after the first delivered inducing pulse, the QT interval during the next cycle may be altered due to the effect of the inducing pulse. Further, it is important to position the inducing pulse on the downward slope, or falling edge of the T-wave. These requirements place additional design burdens on the lead electrode characteristics and the sensing circuitry as used for detecting the T-wave. In order to provide optimum detection of the T-wave and timing of the delivery of the inducing pulse, near field sensing is desired. In other words, it is desired to sense as accurately as possible the repolarization of the heart cells at the location of the tip electrode where the inducing pulse is delivered. Thus, the term embraces any bipolar lead having a tip-to-ring separation substantially less than the conventional bipolar spacing, and in particular less than about 5 mm; or any circuit, e.g., an FDC circuit, that operates to sense the signal substantially as it appears at the cardiac tissue that receives the pacing pulses.

This requirement of near field, or localized sensing, can be achieved with particular benefit by using one of the configurations illustrated in Figs. 4(a), 4(b) and 4(c). In Fig. 4(a), the input circuit 110 comprises an FDC, or field density clamp circuit 52. The field density clamp circuit is disclosed in U.S. Pats. 5,156,149 and 5,233,985, assigned to the same assignee as this invention.

The field density clamp circuit is of advantage in association with a unipolar lead, and is shown having one input connected to ground as illustrated at 142, and the other input connected to tip electrode 138. The FDC circuit acts to essentially clamp the voltage at the tip 138 to that at the indifferent electrode 142, e.g., the pacemaker can, as explained in the above-referenced patents. By this technique, a signal is induced by the FDC circuit which is a highly accurate near field signal representative of the changes in the vicinity of electrode 138. The resulting signal is a narrower, sharper signal, which enables improved timing of the repolarization at the tip electrode. Thus, the combination of an FDC input circuit and a unipolar lead provides a desirable near field T-wave signal for use in connection with this invention. The FDC circuit likewise can be used to advantage for detection of atrial repolarization signals.

It is to be understood that the use of an FDC circuit as part of this invention does not limit the lead design to being unipolar. Thus, a bipolar lead can be employed, e.g., where electrodes 138 and 140 are used for ventricular pacing and R-wave sensing; and a separate FDC sense channel is used for sensing the T-wave between tip electrode 138 and the indifferent electrode (pacemaker can) 142. As shown in Fig. 4(a), FDC circuit 52 and R-wave sense circuit 54 are separate circuits within block 110 (Figure 1); each has filter characteristics and/or window enabling for distinguishing the respective signals portions.

Referring to Fig. 4(b), there is shown an alternate arrangement combining digital signal processing (DSP) circuitry 53 as part of input circuitry 110, with accompanying software, in combination with bipolar sensing from electrodes 138, 140. In this arrangement, ring electrode 140 is suitably close to tip electrode, 138, e.g., less than 10 mm. Such close spacing of the bipolar electrodes yields a sharper near field signal representative of the cell repolarization near the tip electrode 138. For each of the configurations shown in Figs. 4(a) and 4(b) the T-wave is detected as a very narrow, localized signal, such that it is desirable to trigger generation of the inducing pulse virtually immediately upon sensing of the T-wave downslope, or after a small Δt following the T-wave peak.

Fig. 4(c) is a diagram showing the distal end of a lead having an electrode configuration particularly adapted for close, or near field sensing of signals at the location where it is fixed to the heart wall. The electrode may have tines, 139, or any other standard passive or active elements for providing the desired fixation.

5 Also, it may have a porous surface, and the capacity for providing steroid elution, as is well known in the art. However, for purposes of this tachycardia-inducing embodiment, only the electrode configuration is shown. The tip electrode 138-S is of nominal size, e.g., 2-6 mm², and may be made of porous platinum alloy. The ring electrode 140-S has a larger surface, e.g., in the range of 10-36 mm². Importantly, the

10 inter-electrode distance 141 is less than about 1 mm, and preferably less than about 0.5 to .75 mm; and may be reduced to as close to zero as is consistent with the ability to manufacture the lead. The outside of the lead between the two electrodes is a typical casing material which is biocompatible and provides high electrical insulation. Each electrode is connected to a separate conductor, not shown, which runs the length

15 of the lead within casing 146 for providing electrical connections to the pacemaker. By making the electrode spacing less than 1 mm, this electrode configuration provides excellent near field sensing of cardiac signals; it can be used in the atrium for P-wave and atrial repolarization sensing, as well as in the ventricular for R-wave and T-wave sensing. In the specific application of this invention, the T-wave downslope at the site

20 of tip fixation, can be determine by detecting the signal downslope designated DS in Fig. 4(d), which illustrates the sensed near field ventricular intracardial signal compared to the surface ECG. It is seen that this lead provides a distinctive signal which provides a significant improvement for very near-field T-wave detection which, e.g., is important for enhancing the tachy-inducing effectiveness of this invention.

25 The ventricular signal can be inputted to DSP circuitry, as illustrated in Figure 53, for further enhancement of the signal. The electrode arrangement of Fig. 4(c) can likewise be used in the atrium, and has been found to reliably sense P-waves, and also atrial repolarization signals with the absence of any significant far field sensing of R-waves.

The near field sensing embodiments as disclosed herein are particularly suited for the system of this invention, and for use in inducing tachycardia in the atrium or the ventricle. However, they are also useful particularly for obtaining other normally difficult-to-sense cardiac signals, such as atrial repolarizations, and for use
5 in establishing highly accurate timing relative to any sensed cardiac signal. Thus, the near field sensing embodiments are useful in any cardiac application which involves accurate timing of a next pulse relative to a preceding atrial or ventricular depolarization or repolarization.

It is to be noted that the system and method of this invention involve
10 delivery of regular pacing pulses, and thus avoid the need for generating high energy cardioversion or defibrillation-type pulses. Suitably the inducing pulses delivered in accordance with this invention are approximately double the pacing threshold value. For each delivered inducing pulse of the programmed series of pulses, the standard level inducing pulses are delivered in very closely timed relation to cell repolarization
15 in the vicinity of the electrode or electrodes used to deliver the pulses.

CLAIMS:

1. A system for inducing an abnormally high rate in a patient's heart, comprising:
 - stimulus pulse means for generating and delivering a series of stimulus pulses at a predetermined rate to a heart chamber of said patient,
 - sensing means for sensing a predetermined portion of each repolarization wave which follows each depolarization wave evoked by a said stimulus pulse, and
 - inducing means for triggering said stimulus pulse means to generate an inducing pulse following each said sensed predetermined repolarization wave portion, said inducing means comprising timing means for timing each said inducing pulse in a predetermined time relation to said repolarization wave portion, whereby a series of inducing pulses are delivered.
2. The system as described in claim 1, further comprising means operative before delivery of said series of stimulus pulses for controlling said stimulus pulse means to generate pacing signals at a rate higher than the patient's spontaneous depolarization rate, whereby said stimulus pulse means delivers a series of pacing pulses which overdrive said chamber of said patient's heart.
3. The system as described in claim 1 or 2, wherein said stimulus pulse means comprises series means for generating a series of 1 to 5 pairs of pulses, each said pair comprising a said stimulus pulse and a said inducing pulse.
4. The system as described in any one of claims 1 to 3, wherein said inducing means comprises means for generating each said inducing pulse immediately upon the sensing of a said repolarization wave portion.

5. The system as described in any one of claims 1 to 3, wherein said inducing means comprises means for generating each said inducing pulse after a predetermined short time delay following the sensing of said repolarization wave portion.

5 6. The system as described in any one of claims 1-5, wherein said stimulus pulse means, said sensing means and said inducing means comprise components of an implantable stimulator.

10 7. The system as described in any one of claims 1 to 6, further comprising confirmation means for confirming when a tachycardia has been induced.

15 8. The system as described in claim 7, comprising rate means for sensing said patient's spontaneous depolarization rate, and wherein said control means has rate control means for setting the rate of said stimulus pulses just higher than said spontaneous depolarization rate, and wherein said confirmation means has means for identifying tachycardia when a spontaneous depolarization is sensed before a said stimulus pulse is due to be delivered.

20 9. The system as described in claim 8, further comprising means responsive to a spontaneous depolarization which is sensed before a next said stimulus pulse is due to be delivered, for inhibiting delivery of a next said stimulus pulse.

25 10. The system as described in any one of claims 1 to 6, comprising means operative after said series of stimulus pulses has been delivered for confirming whether tachycardia has been induced.

30 11. The system as described in any one of claims 1-10, wherein said heart chamber is a ventricle, and said sensing means comprises means for sensing T waves and for sensing a predetermined portion of each sensed T wave.

12. The system as described in claim 1, wherein said stimulus pulse means comprises a lead with at least one electrode for delivery of stimulus pulses at a location of a predetermined one of the patient's heart chambers, said lead having a conductor for conducting said pacing pulses from said generator to said electrode and wherein said sensing means comprises near field means electrically connected to said electrode for sensing repolarization waves from near said location and for determining the timing of a portion of each said repolarization wave.

13. The system as described in claim 12, wherein said heart chamber is a ventricle, and said near field means has means for sensing T waves and for determining the timing of a predetermined portion of each sensed T wave.

14. The system as described in claim 12, wherein said near field means comprises an FDC circuit with an input connected to said at least one electrode, and said lead is a unipolar lead and said one electrode is a tip electrode.

15. The system as described in claim 12, wherein said lead is a bipolar lead and said at least one electrode is a tip electrode, said lead having a ring electrode proximal to said tip electrode, the spacing between said tip and ring electrodes being less than about 0.75 mm.

16. The system as described in claim 15, wherein said tip electrode has a surface area of 2-6 square mm, and said ring electrode has a surface area greater than 10 square mm.

17. An implantable pacing system, comprising:
a pacing pulse generator for generating pacing pulses;
a lead with at least one electrode for delivery of pacing pulses at a location of a predetermined one of the patient's heart chambers, said lead having a conductor for conducting said pacing pulses from said generator to said electrode;
near field means electrically connected to said electrode for sensing repolarization waves from near said location and for determining the timing of a predetermined portion of each said repolarization wave; and
control means for controlling the timing of generation of pacing pulses by said generator, said control means having series means for controlling generation of a first series of pacing pulses for evoking heartbeats, said inducing means controlling generation of an inducing pacing pulse as a function of the timing of each said repolarization portion evoked by a pacing pulse of said first series.
18. The system as described in claim 17, wherein said heart chamber is a ventricle, and said near field means has means for sensing T waves and for determining the timing of a predetermined portion of each sensed T wave.
19. The system as described in claim 17 or 18, wherein said inducing means comprises increment means for controlling the timing of generation of a next inducing pace pulse after a predetermined time increment following the time of a said wave portion.
20. The system as described in claim 17, wherein said near field means comprises an FDC circuit with an input connected to said at least one electrode, and said lead is a unipolar lead and said one electrode is a tip electrode.

21. The system as described in any one of claims 17 to 19, wherein said lead is a bipolar lead and said at least one electrode is a tip electrode, said lead having a ring electrode proximal to said tip electrode, the spacing between said tip and ring electrodes being less than about 0.75 mm.

22. The system as described in claim 21, wherein said tip electrode has a surface area of 2-6 square mm, and said ring electrode has a surface area greater than 10 square mm.

23. A system for inducing an abnormally high rate in a patient's ventricle, comprising:

 pacing pulse means for generating a series of pacing pulses at about a predetermined rate;

 lead means for delivering said pacing pulses to a location of said ventricle;

 near field means for obtaining near field T wave signals from near said location, and determining means for determining a falling edge portion of each said near field T wave signal; and

 inducing means for triggering said pacing pulse means to generate an inducing pulse following each said determined falling edge portion, said inducing means comprising timing means for timing an inducing pulse in a predetermined time relation to each said near field T wave signal, whereby a series of inducing pulses are delivered to said patient's ventricle.

24. The system as described in claim 23, comprising rate means for controlling said pacing pulse generator to deliver said series of pacing pulses at a rate greater than said patient's spontaneous rate.

25. The system as described in claim 23 or 24, wherein said lead means comprises a tip electrode, an indifferent electrode located at a distance from said tip electrode, and an FDC circuit is connected in a unipolar mode to receive sensed signals between said tip electrode and said indifferent electrode.

26. The system as described in claim 23, comprising series means for controlling said pacing pulse generator to deliver series of 1-5 pacing pulses and respective inducing pulses.

27. The system as described in claim 26, comprising energy control means for controlling said pacing pulse generated to generate said inducing pulses with an energy level no greater than about twice the patient pacing threshold.

28. The system as described in claim 23, wherein said inducing means comprises means for generating each said inducing pulse immediately upon determining said T wave falling edge portion.

29. The system as described in claim 23, wherein said inducing means comprises means for generating each said inducing pulse after a predetermined time delay following a determined T wave falling edge portion.

30. A system for inducing an abnormally high rate in a patient's ventricle, comprising:

pacing pulse means for generating a series of pacing pulses at about a predetermined rate;

lead means for delivering said pacing pulses to a location of said ventricle and for

sensing cardiac signals, said lead means having a tip electrode for positioning at about said location and a ring electrode spaced proximally from said electrode by an inter-electrode distance of less than about 1 mm, whereby near field T wave signals are obtained between said electrodes; and

inducing means for triggering said pacing pulse means to generate an inducing pulse following each said obtained near field T wave signal, said inducing means comprising timing means for timing an inducing pulse in a predetermined time relation to each said near field T wave signal, whereby a series of inducing pulses are delivered to said patient's ventricle.

31. The system as described in claim 30, comprising rate means for controlling said pacing pulse generator to deliver said series of pacing pulses at a rate greater than said patient's spontaneous rate.

32. The system as described in claim 30 or 31, wherein said tip electrode has a surface area of no more than about 6-8 square mm, and said ring electrode has a surface area of greater than 20 square mm

33. The system as described in claim 30, comprising series means for controlling said pacing pulse generator to deliver a series of 1-5 pacing pulses and respective inducing pulses.

34. The system as described in any one of claims 30 to 33, comprising energy control means for controlling said pacing pulse generated to generate said inducing pulses with an energy level no greater than about twice the patient pacing threshold.

35. The system as described in claim 30, wherein said inducing means

comprises means for generating each said inducing pulse immediately upon obtaining said near field T wave signal.

36. The system as described in claim 30, wherein said near field means comprises means for determining the time of occurrence of a predetermined portion of a said near field T wave signal, and wherein said inducing means comprises means for generating each said inducing pulse after a predetermined time delay following said occurrence.

37. The system as described in any one of claims 30 to 36, wherein said inter-electrode distance is less than about 0.75 mm.

FIG. 1

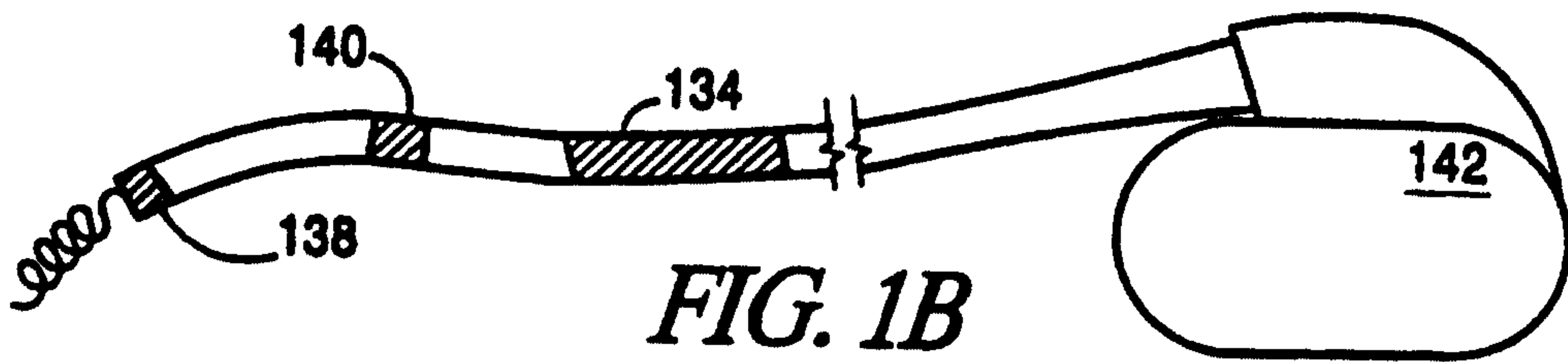
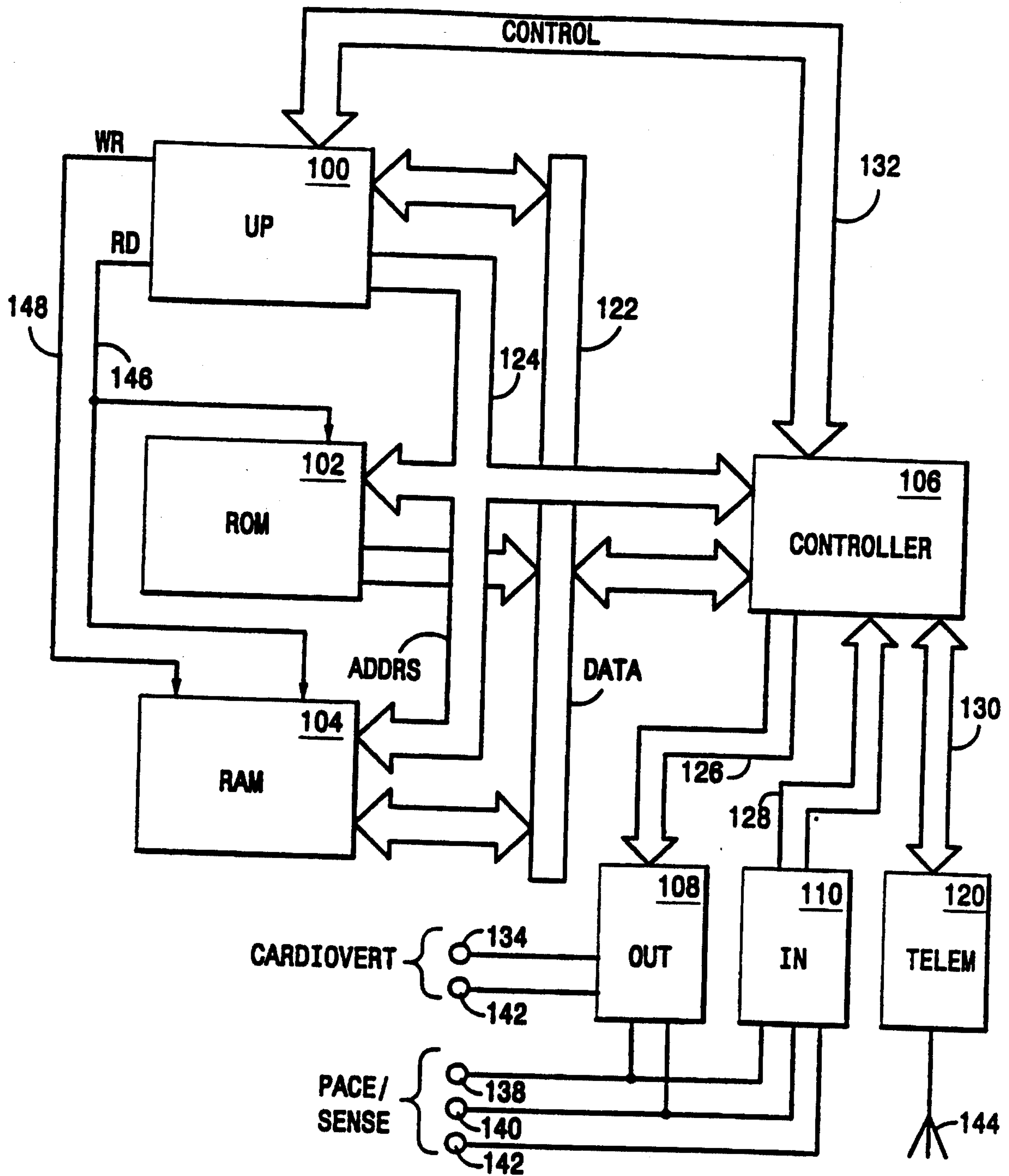

FIG. 1B

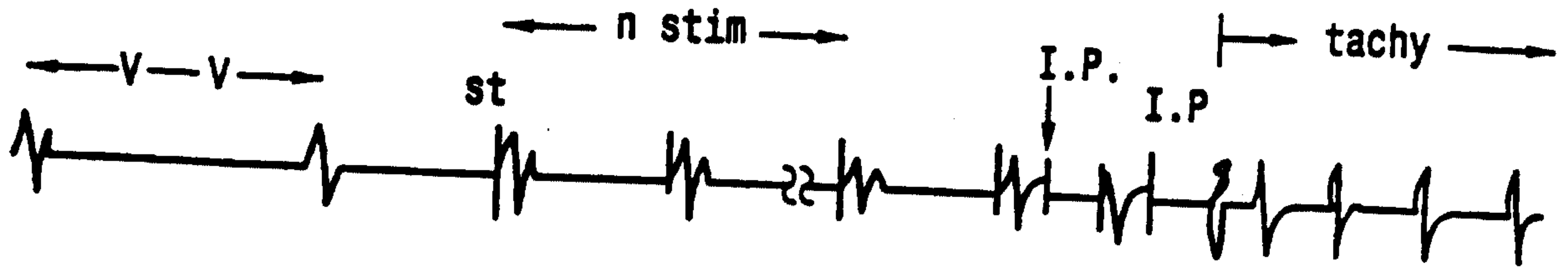

FIG. 2A

FIG. 2B

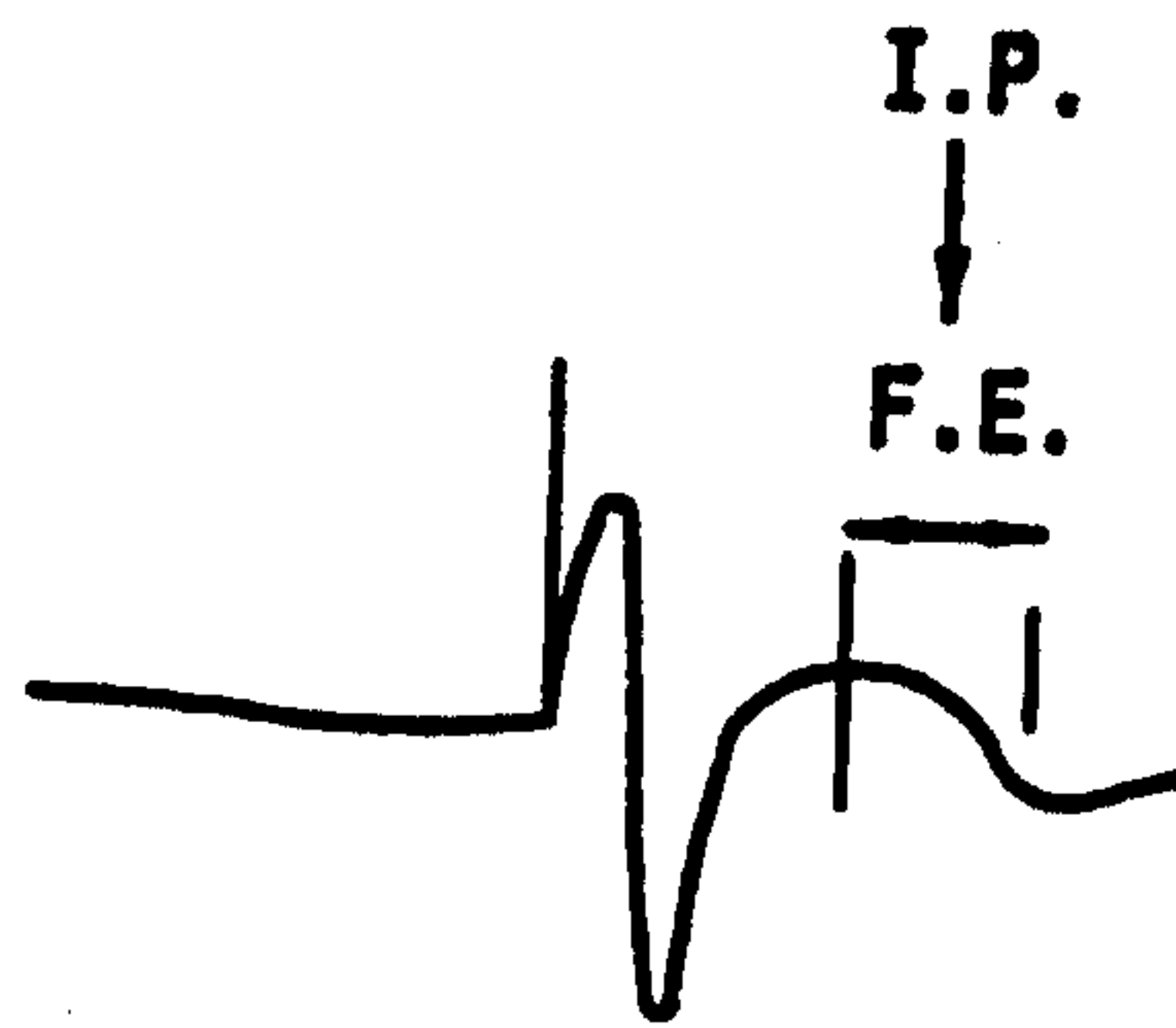

FIG. 2C

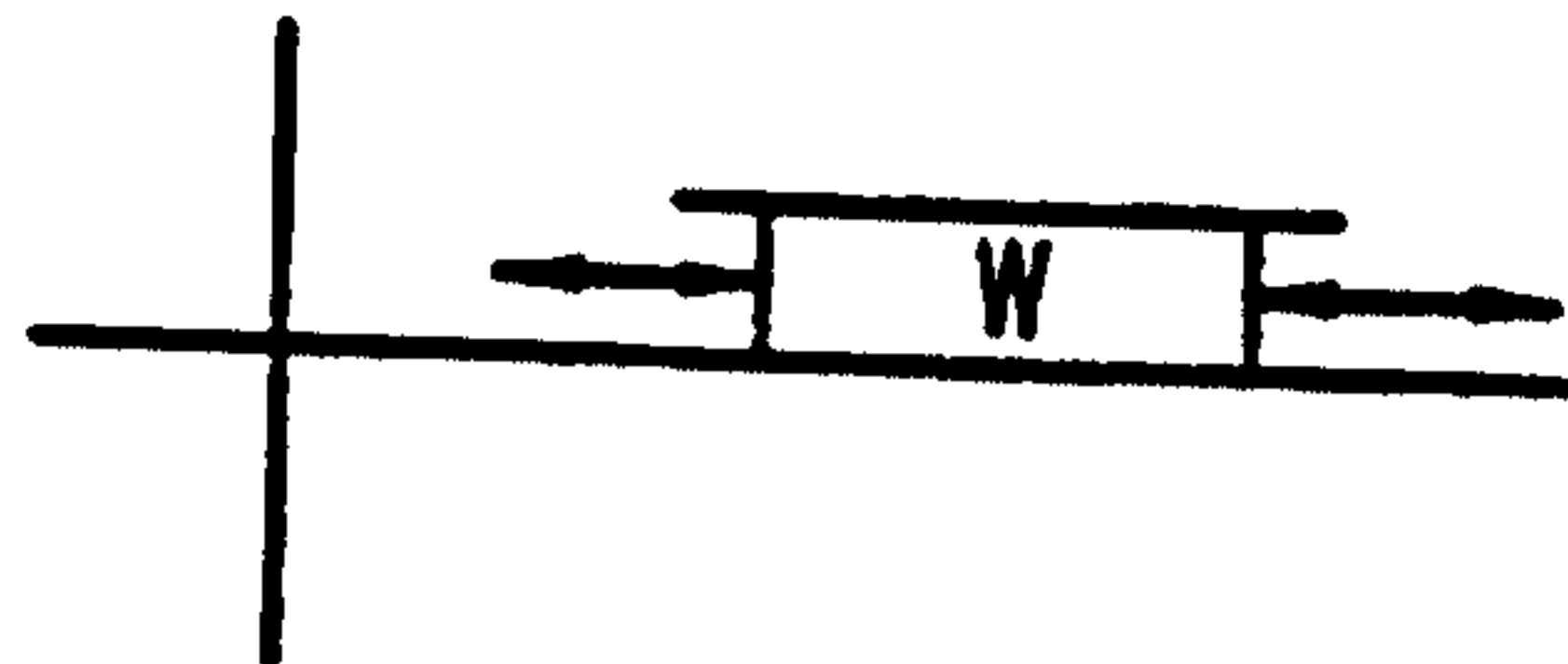
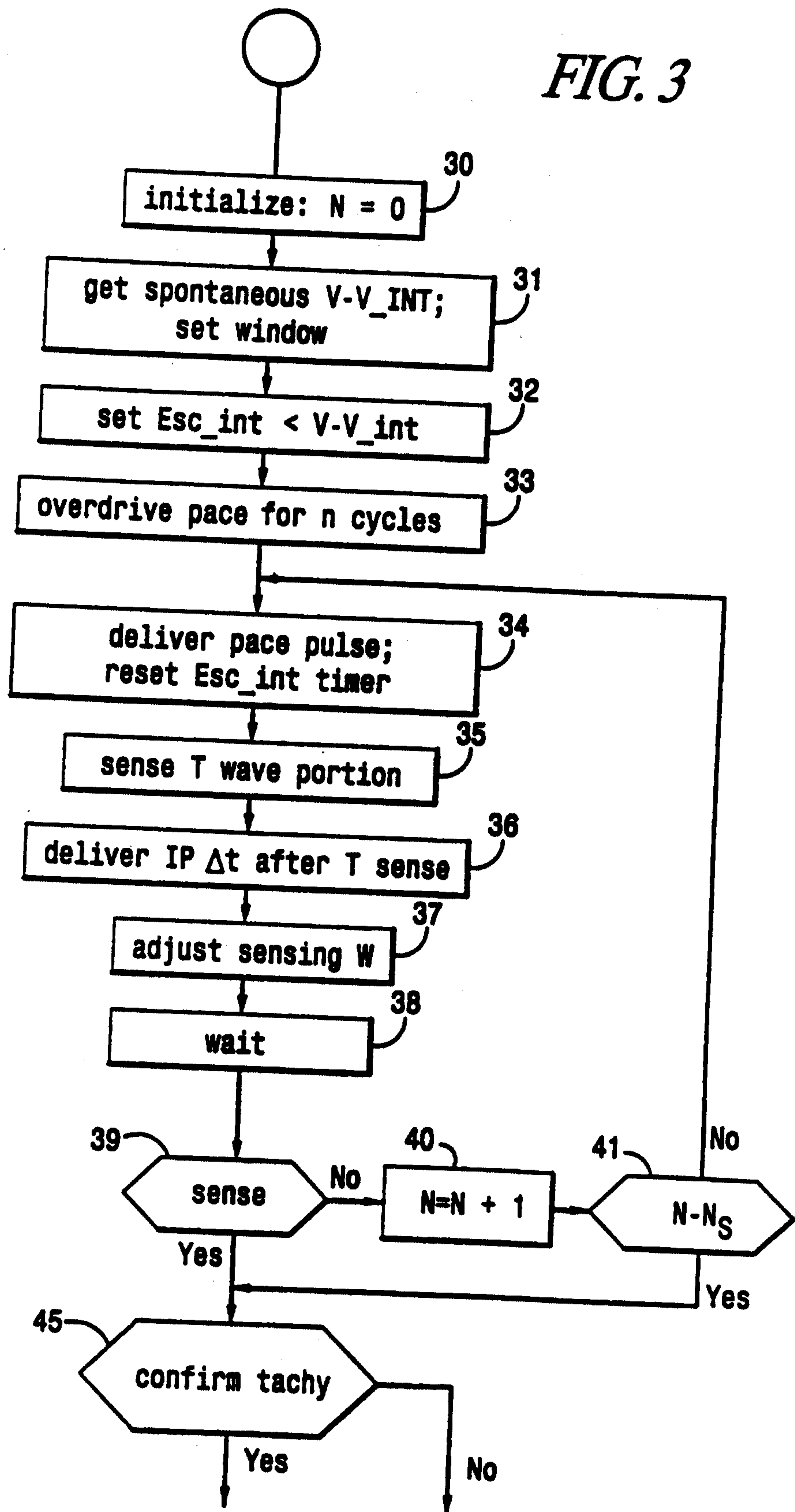
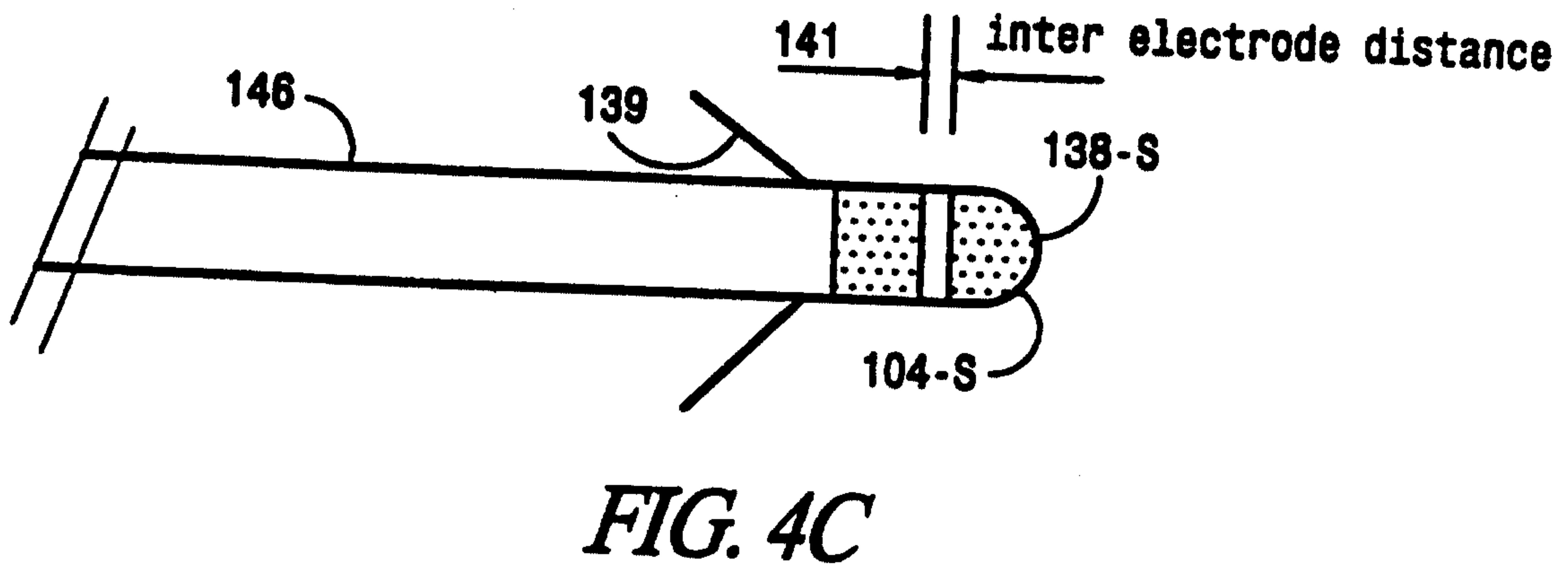
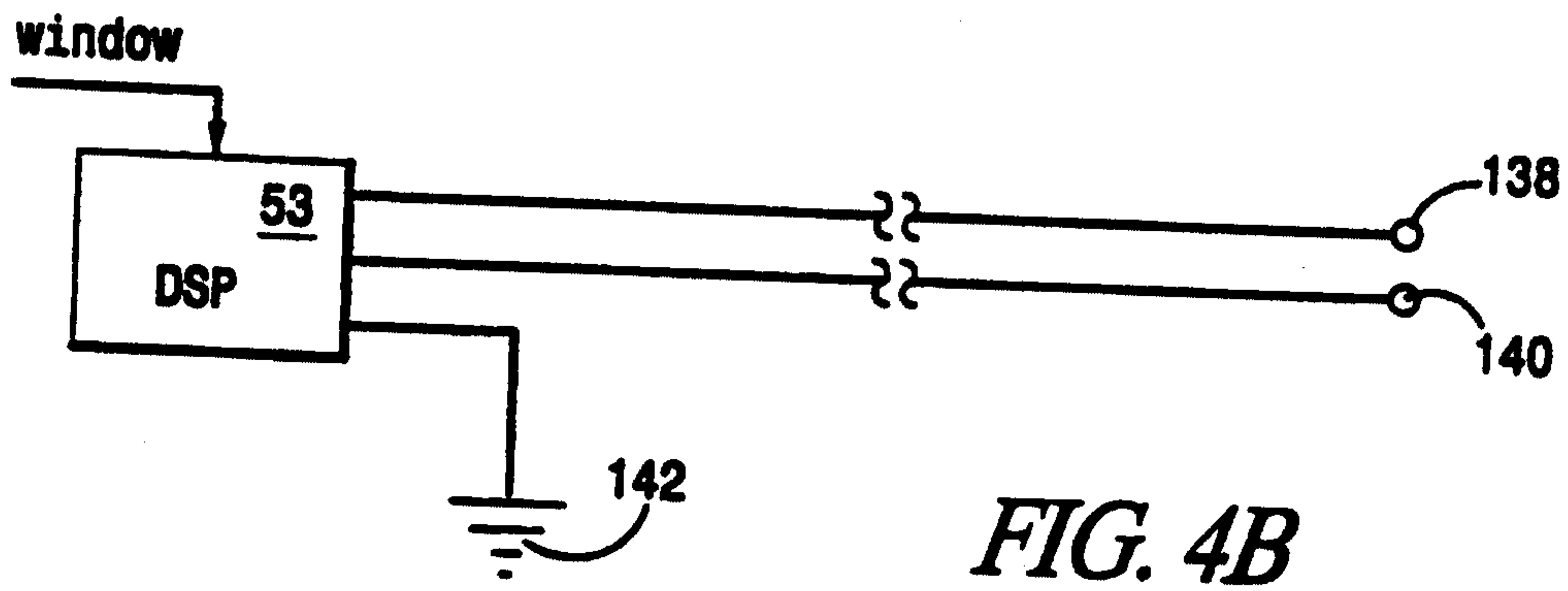
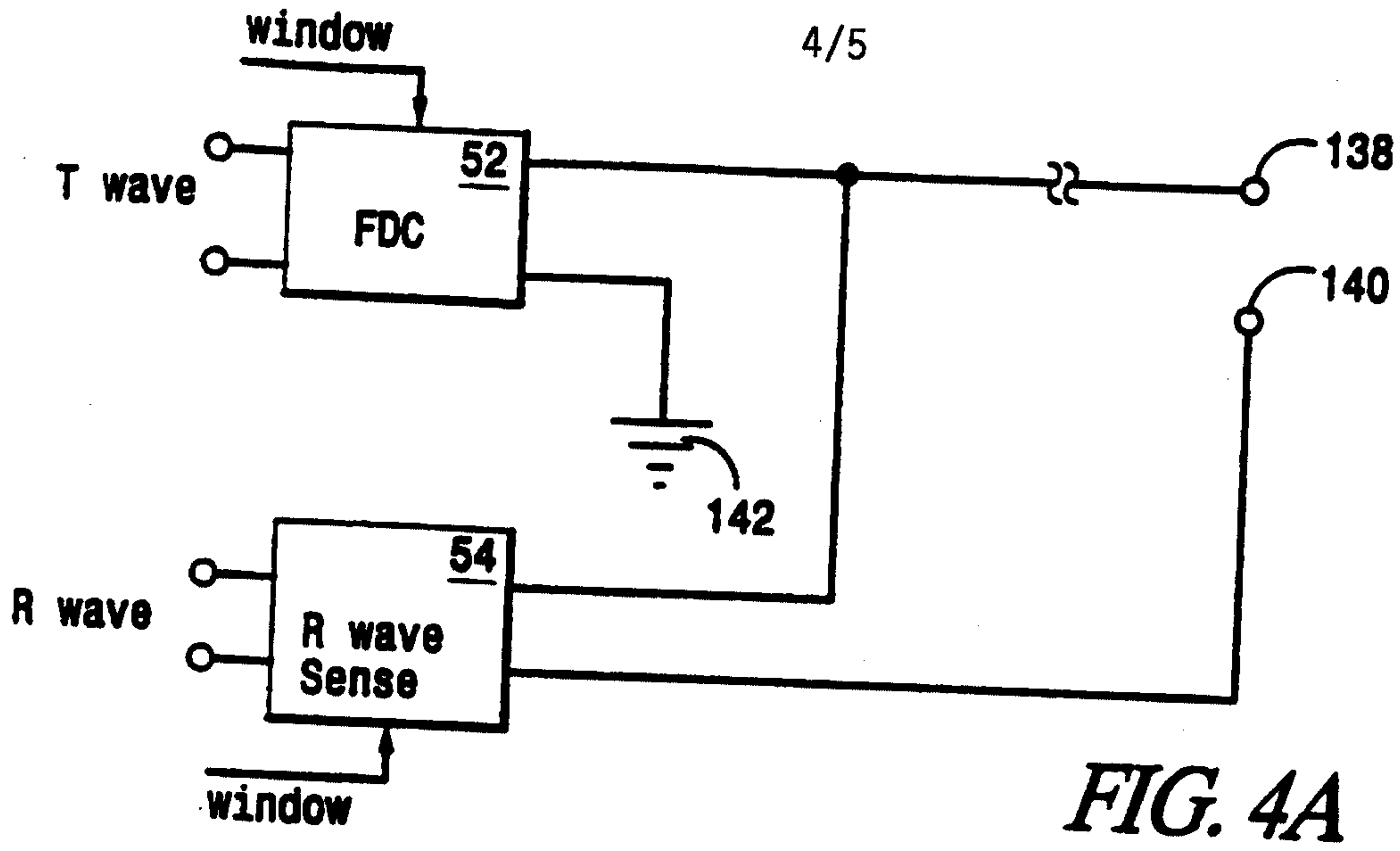

FIG. 3





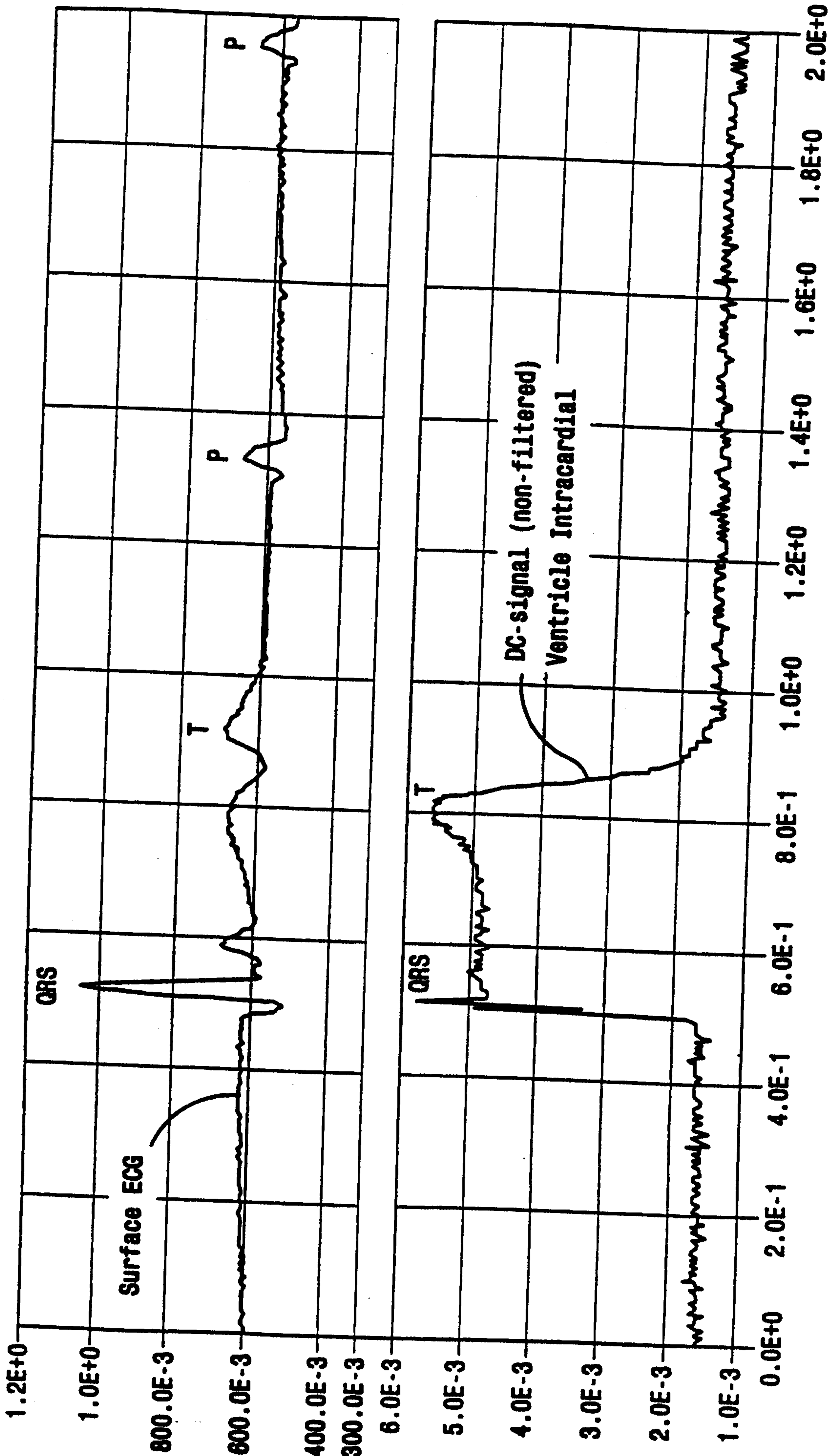

FIG. 4D

