



US 20100088859A1

(19) **United States**

(12) **Patent Application Publication**
Derscheid et al.

(10) **Pub. No.: US 2010/0088859 A1**

(43) **Pub. Date: Apr. 15, 2010**

(54) **WRAPPING MATERIAL WITH FASTENER**

Publication Classification

(75) Inventors: **Daniel Eric Derscheid**, Hendrick, IA (US); **Hagai Paz**, Ha' Emek (IL); **Yair Efrati**, Ha' Emek (IL); **Henry Dennis Anstey**, Ottumwa, IA (US)

(51) **Int. Cl.**
B65D 63/00 (2006.01)

(52) **U.S. Cl.** **24/16 R**

Correspondence Address:

**LERNER, DAVID, LITTENBERG,
KRUMHOLZ & MENTLIK
600 SOUTH AVENUE WEST
WESTFIELD, NJ 07090 (US)**

(57) **ABSTRACT**

A wrapping material for wrapping an item about its circumference having a plurality of wrapping portions forming a continuous roll. Each wrapping portion has a length that is greater than the circumference of an item to be wrapped with a width that is transverse to its length. Each of the wrapping portions include at least one fastener secured in an area there such that the continuous roll includes a plurality of serially disposed fasteners that are spaced from one another along the continuous roll. Each fastener includes a plurality of engaging elements for engaging a plurality of fiber elements of an underlying or overlying segment of a respective wrapping portion during a wrapping cycle. With this arrangement, the tail end of a respective wrapping portion will be secured by the plurality of engaging elements to the underlying or overlying segment at the end of a wrapping cycle.

(73) Assignee: **Tama Plastic Industry**, Ha' Emek (IL)

(21) Appl. No.: **12/653,363**

(22) Filed: **Dec. 11, 2009**

Related U.S. Application Data

(62) Division of application No. 11/288,113, filed on Nov. 29, 2005, now Pat. No. 7,636,987.

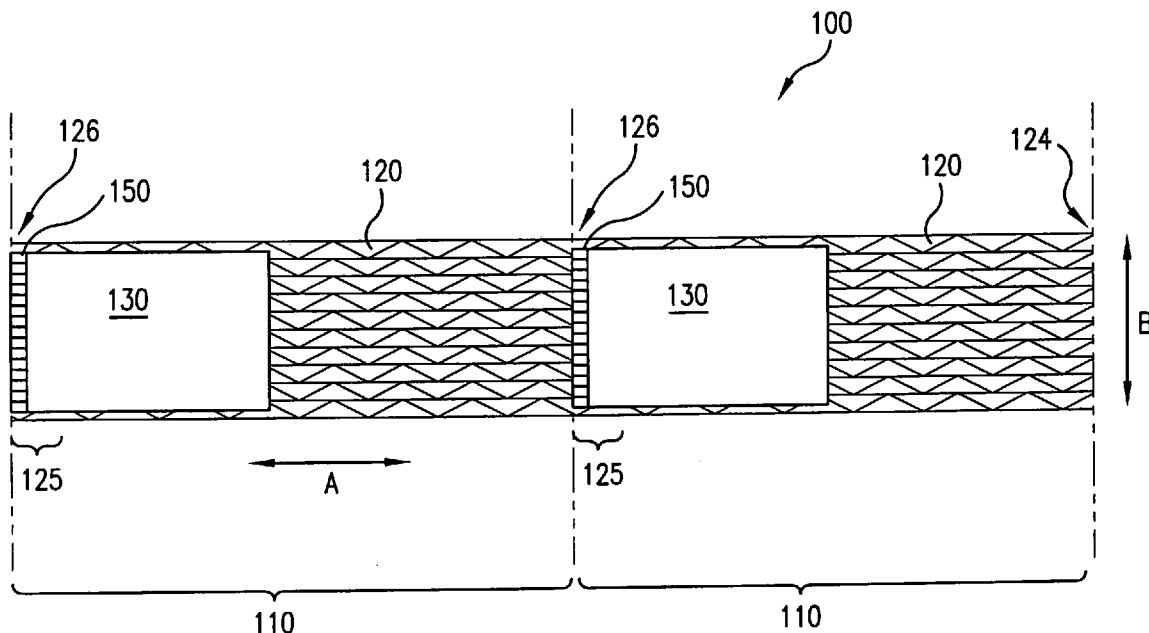

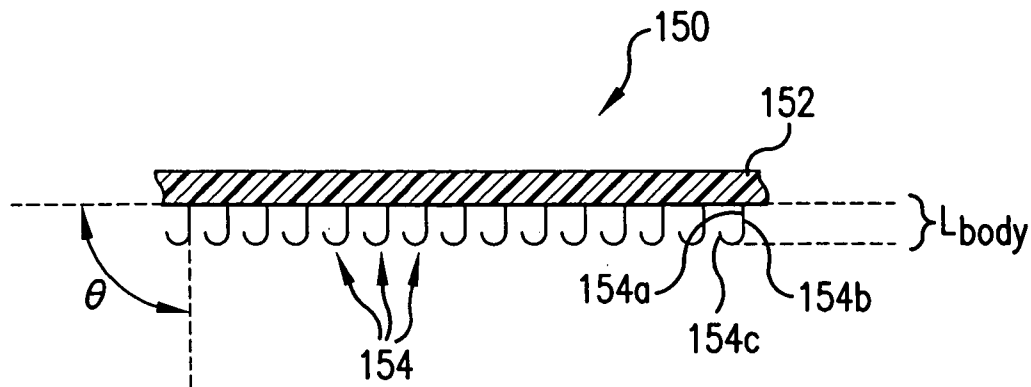

FIG. 1 A

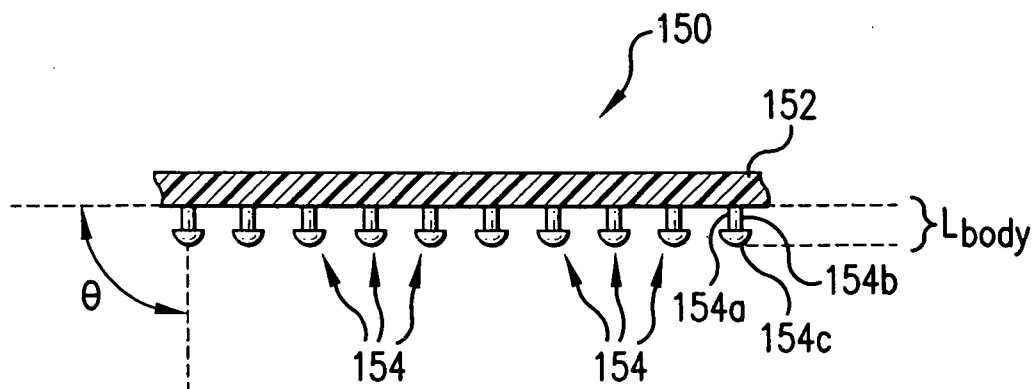

FIG. 1 B

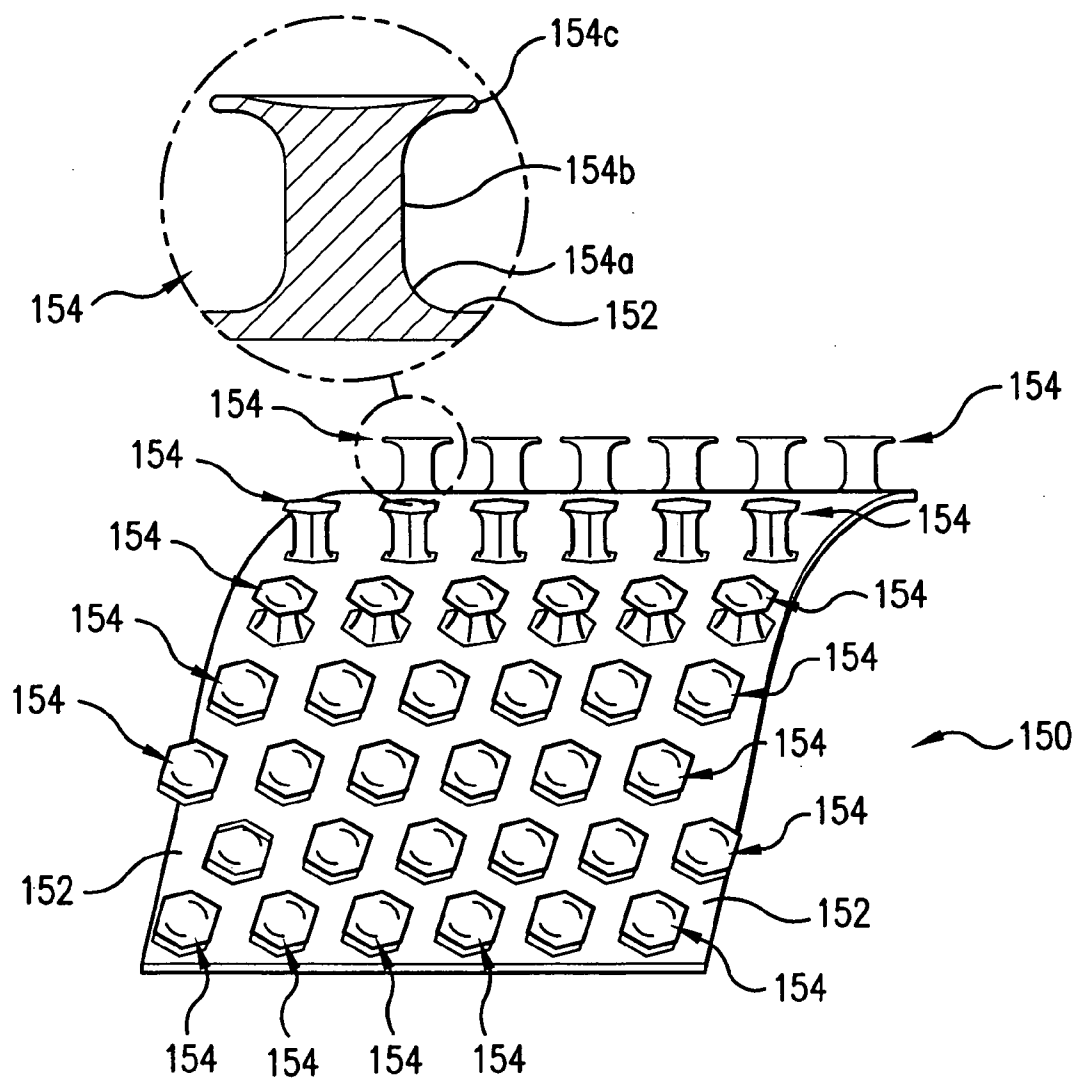

FIG. 1C

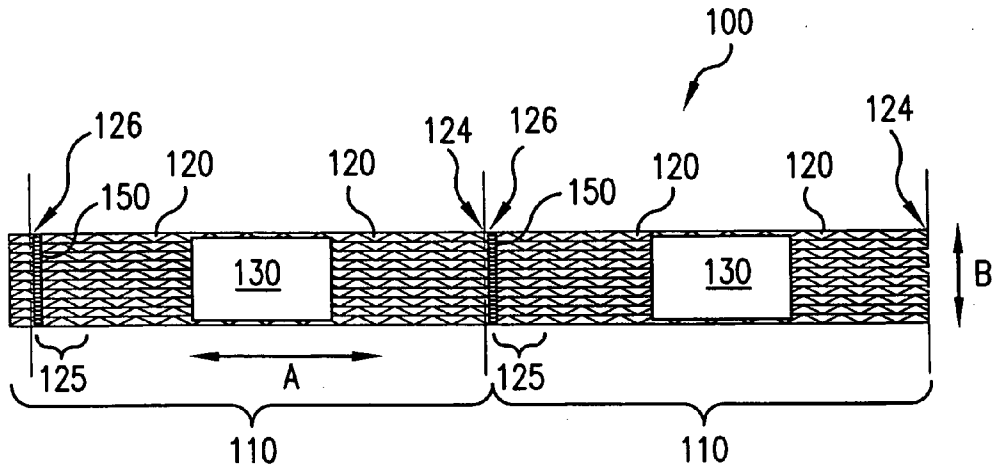

FIG.2A

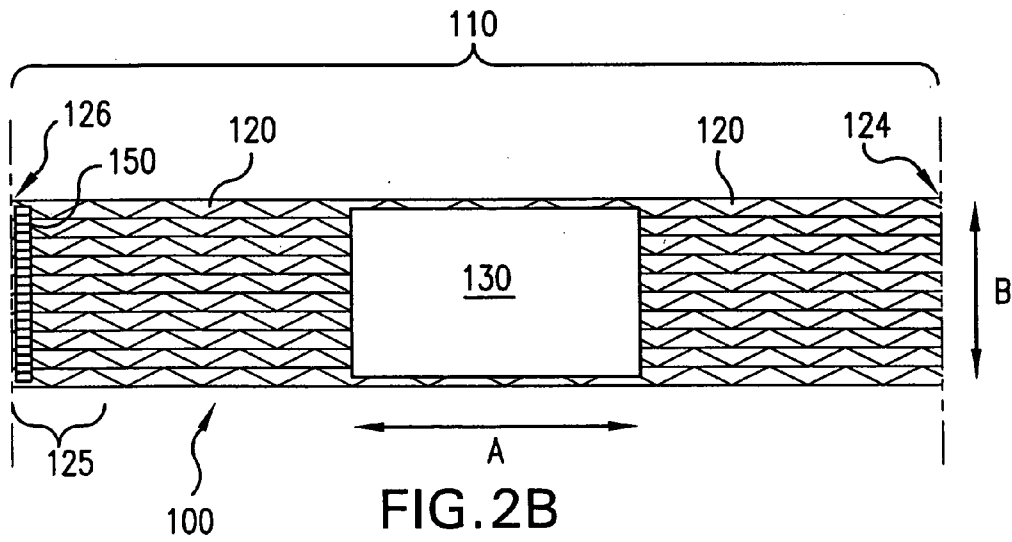

FIG.2B

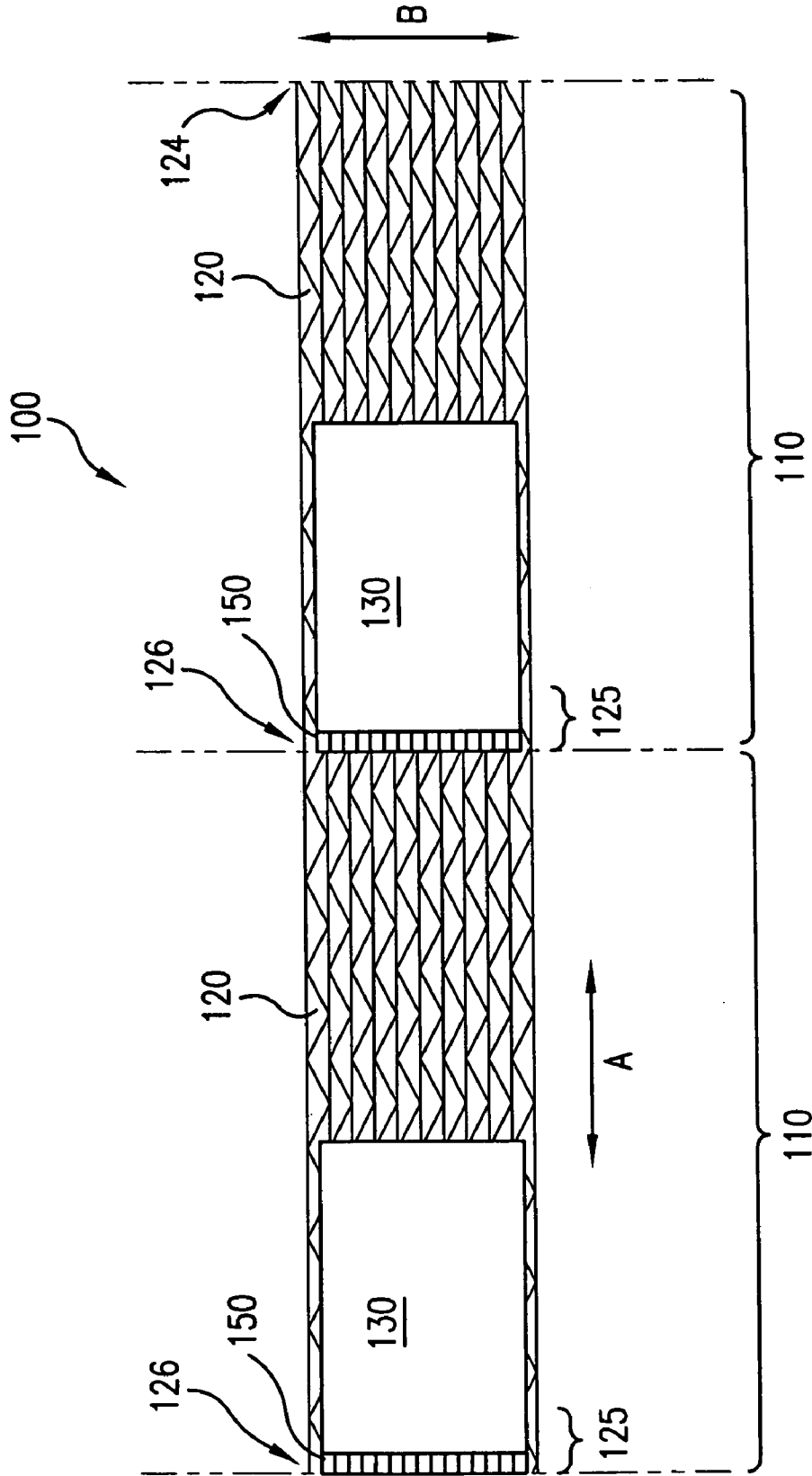

FIG. 2C

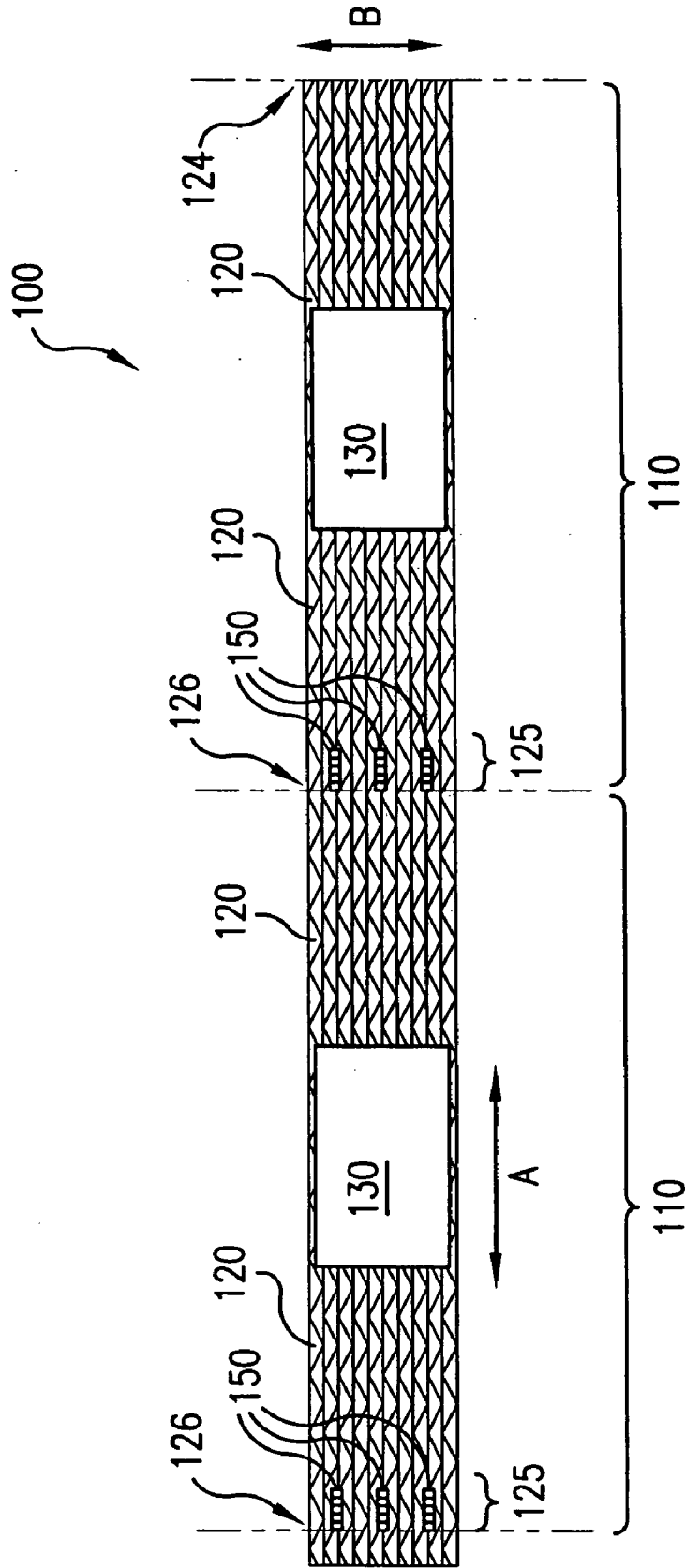

FIG. 3A

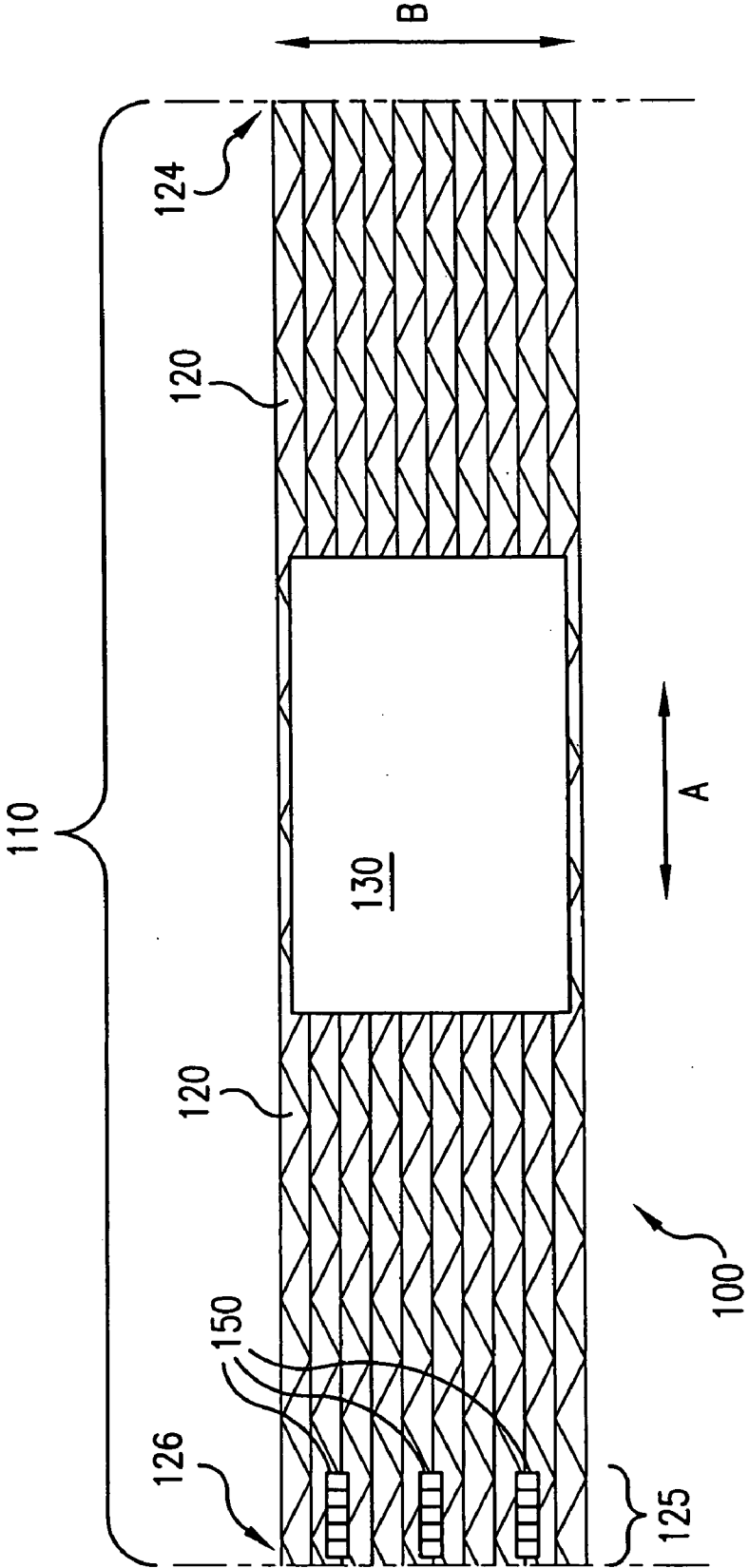

FIG.3B

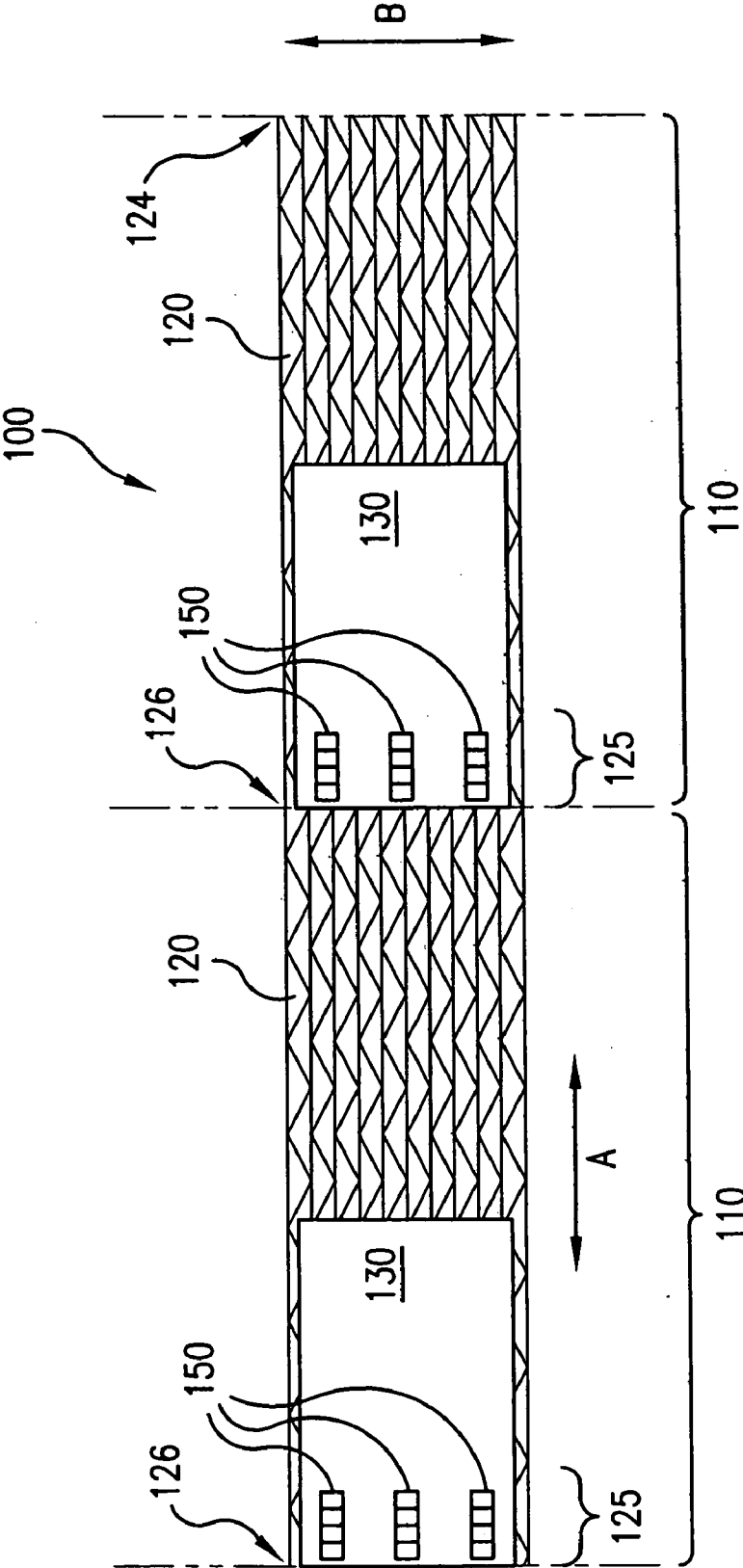

FIG.3C

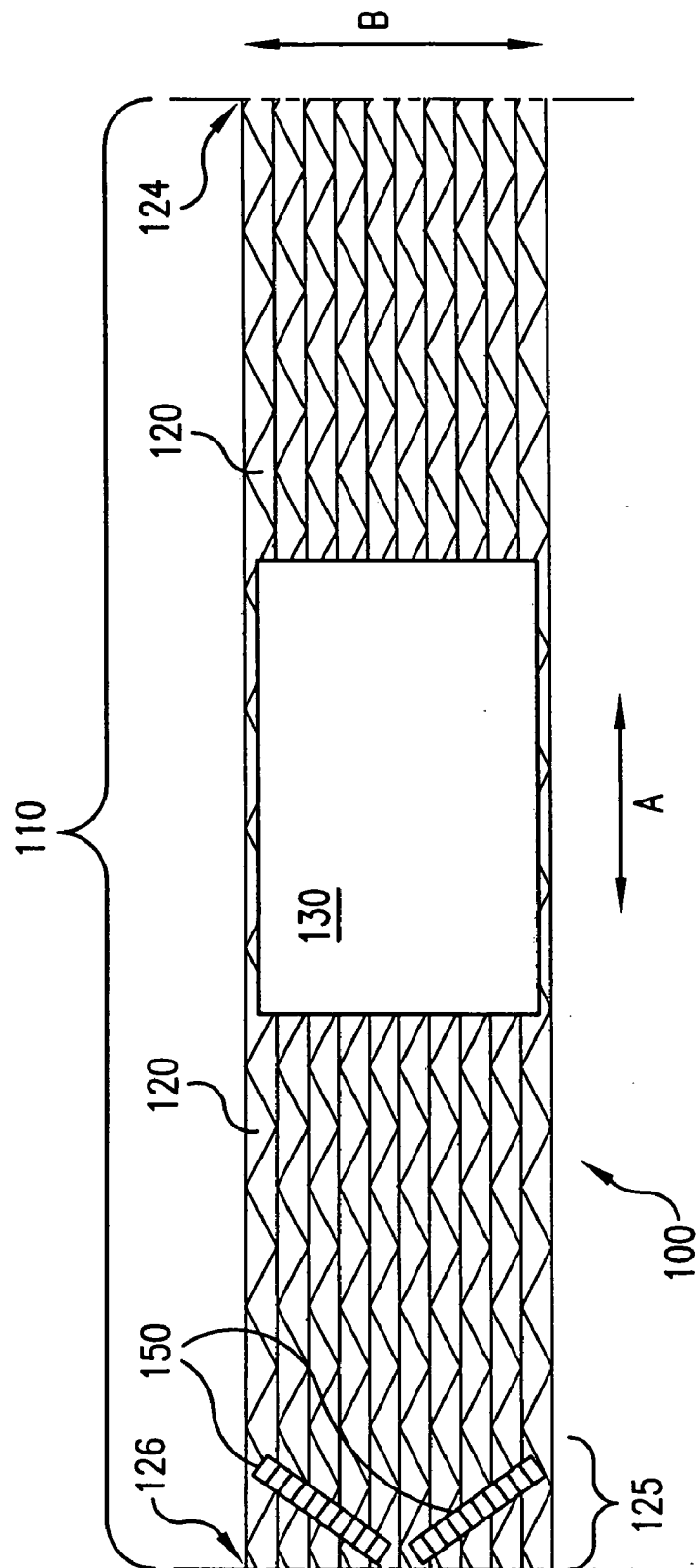

FIG.4

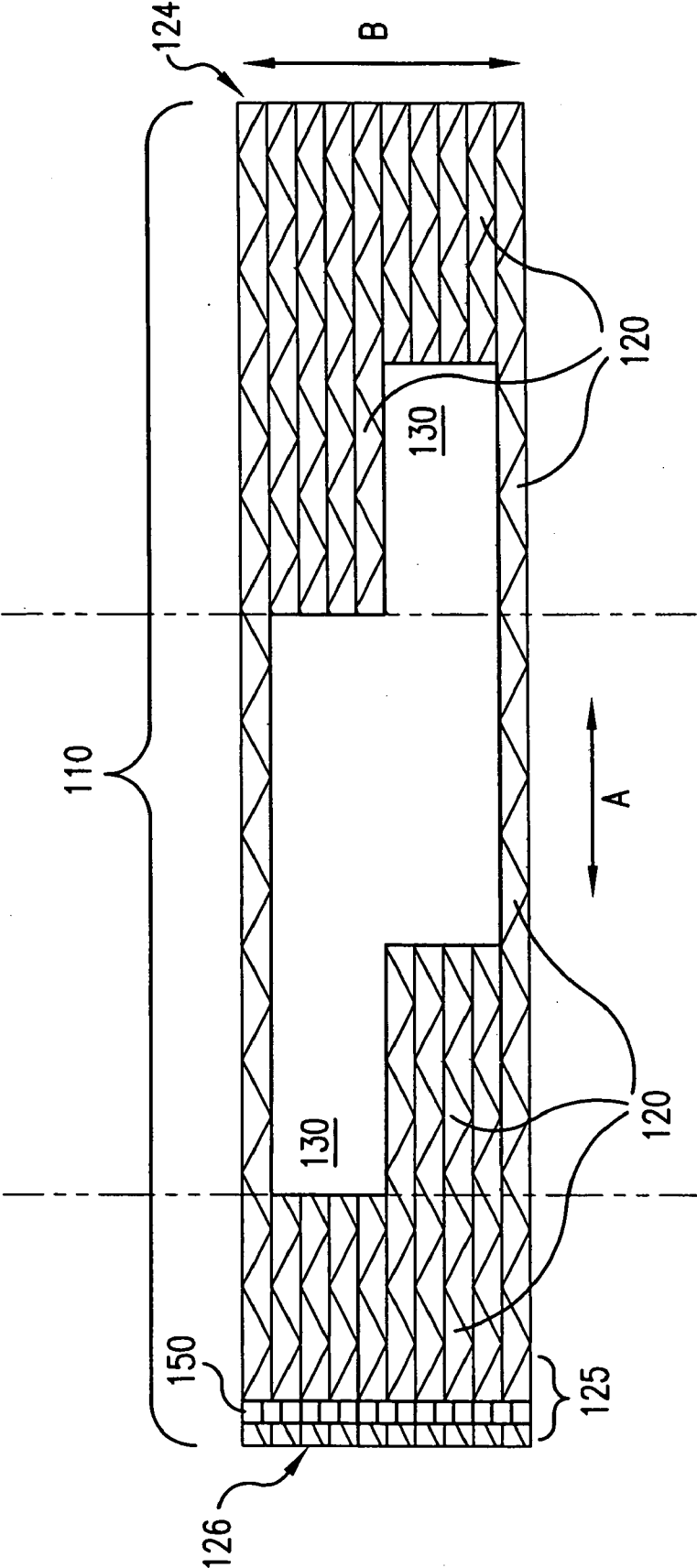

FIG.5

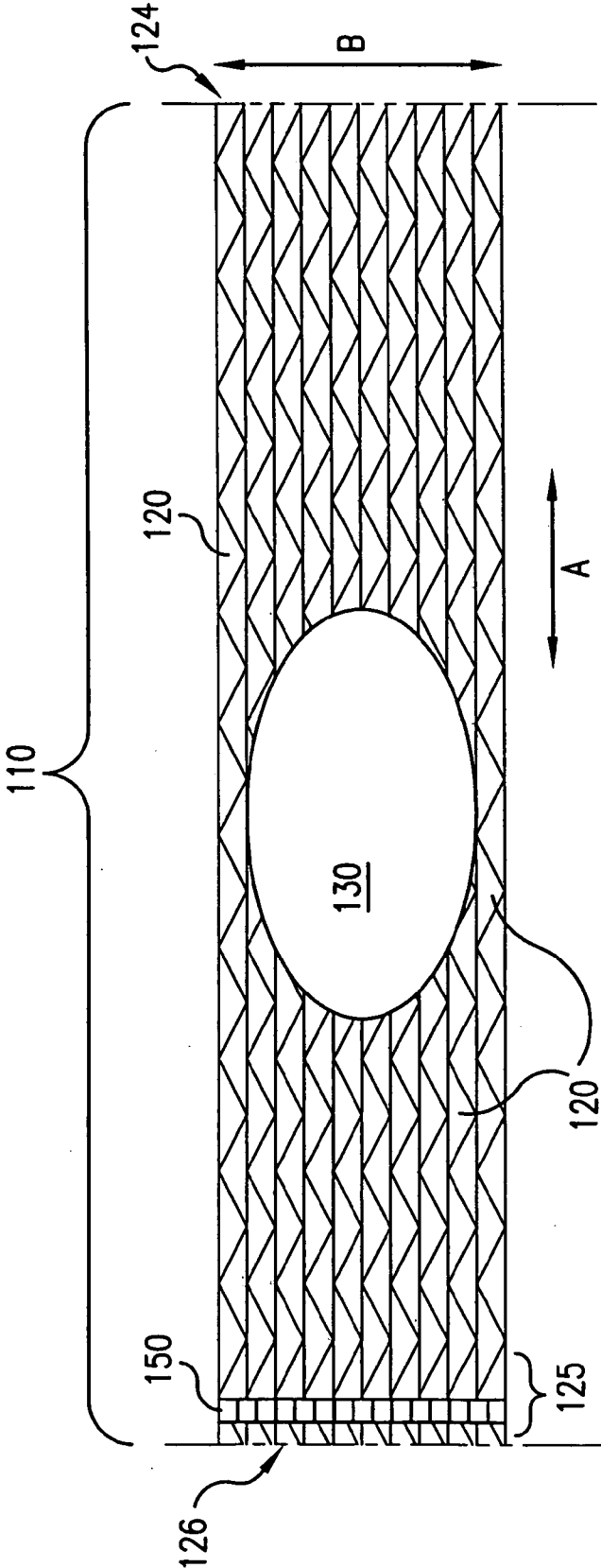

FIG. 6

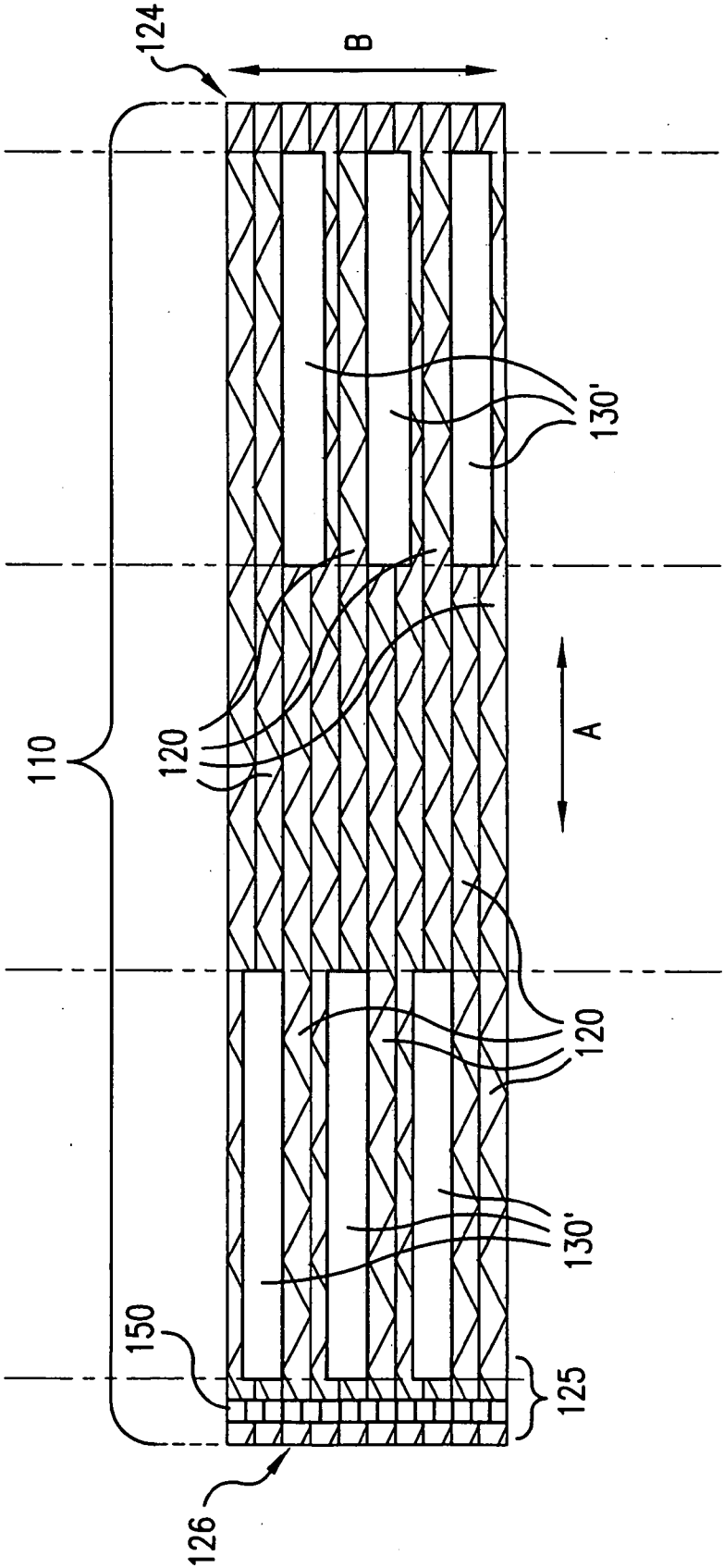

FIG. 7

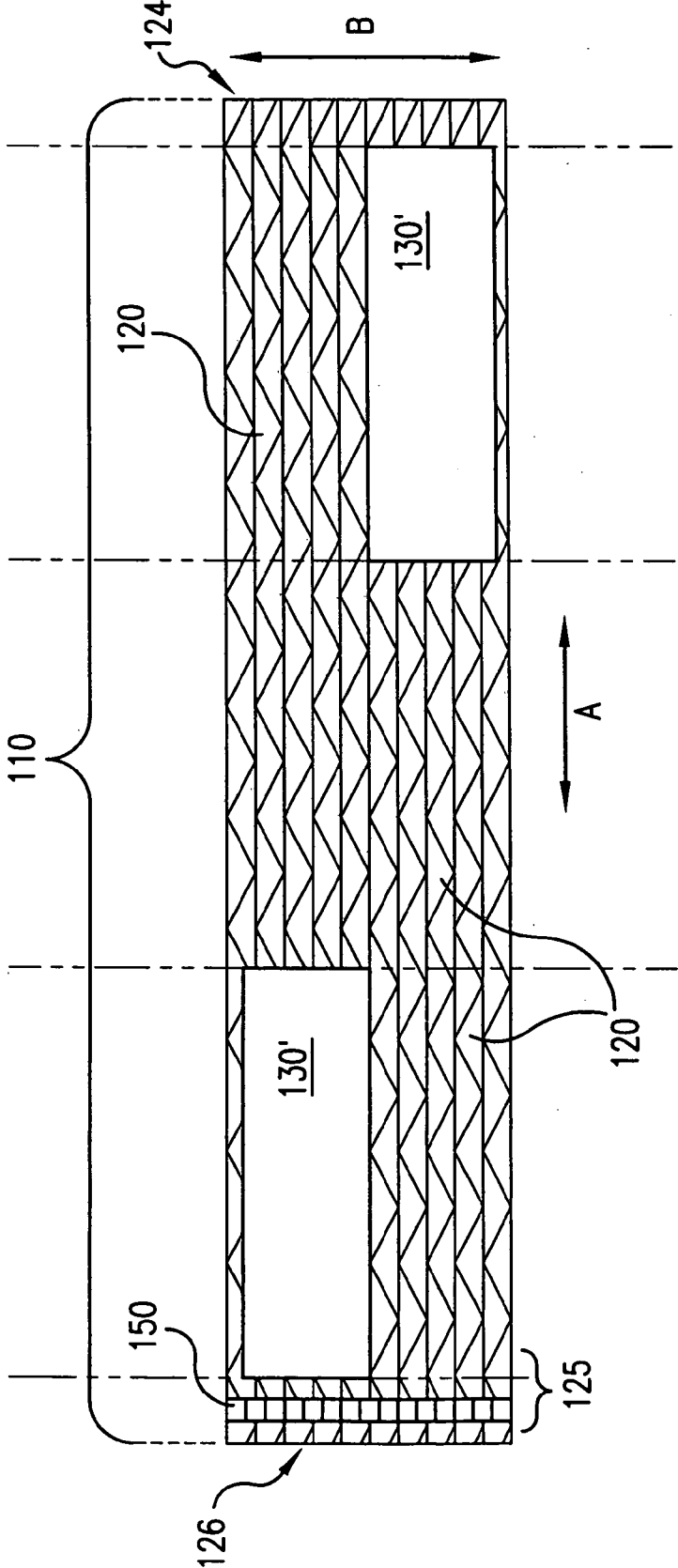

FIG.8

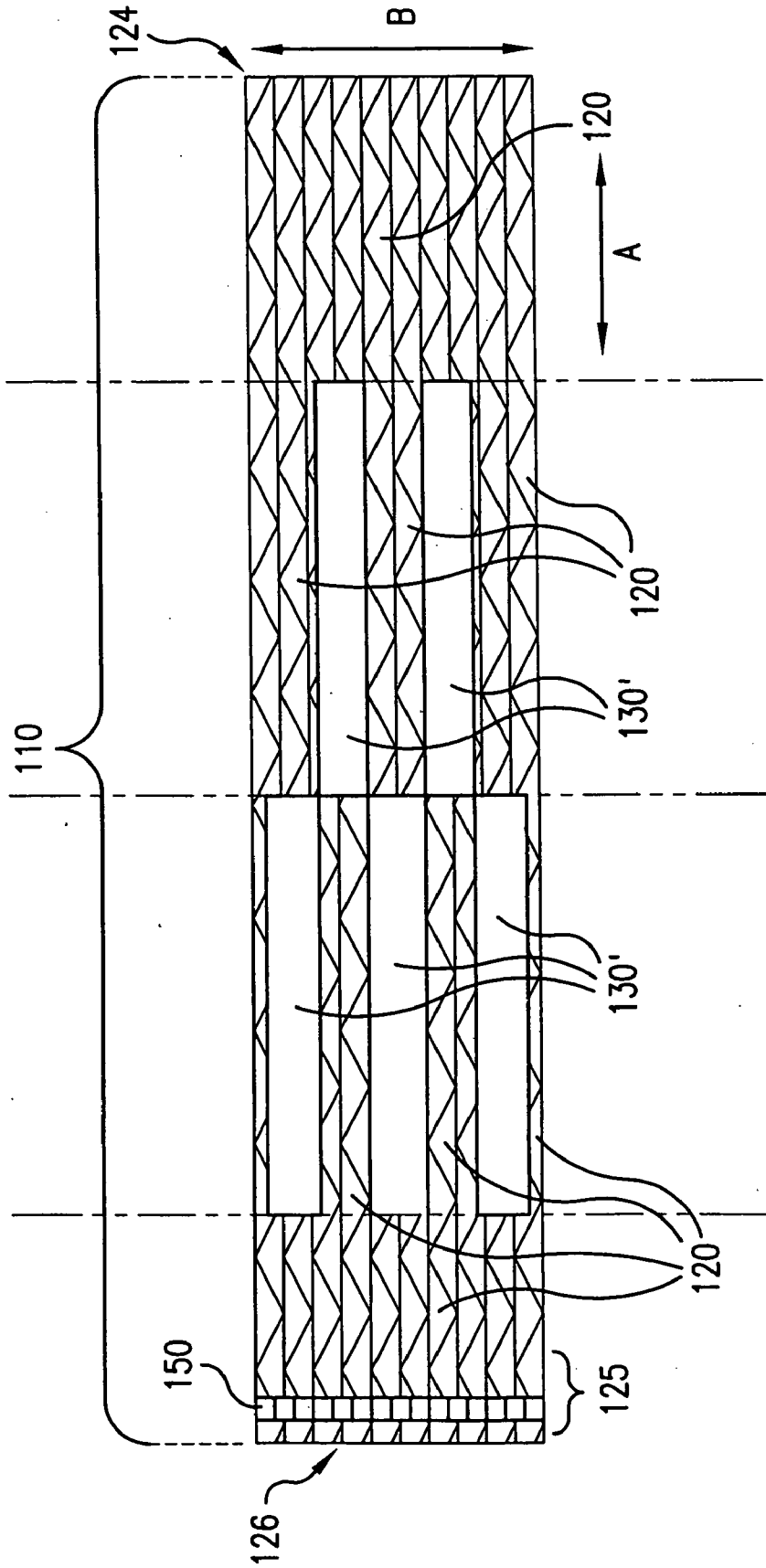

FIG. 9

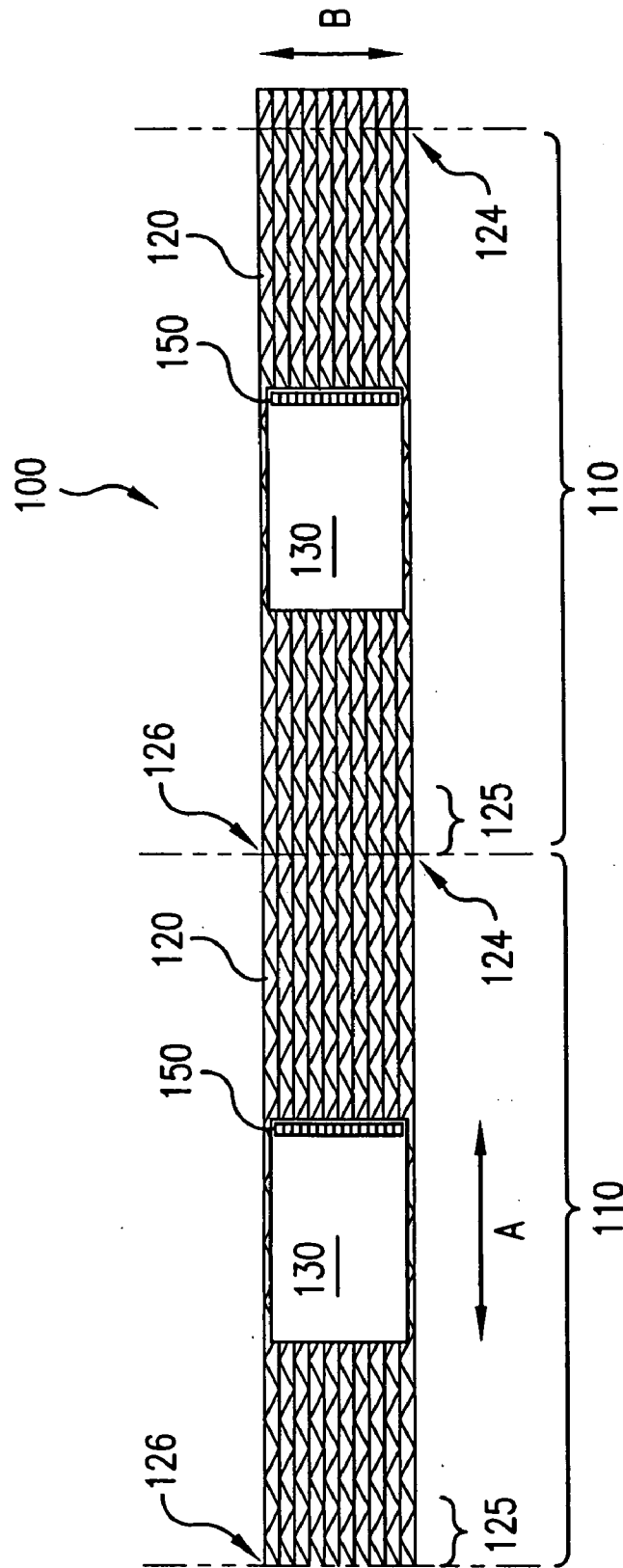

FIG. 10

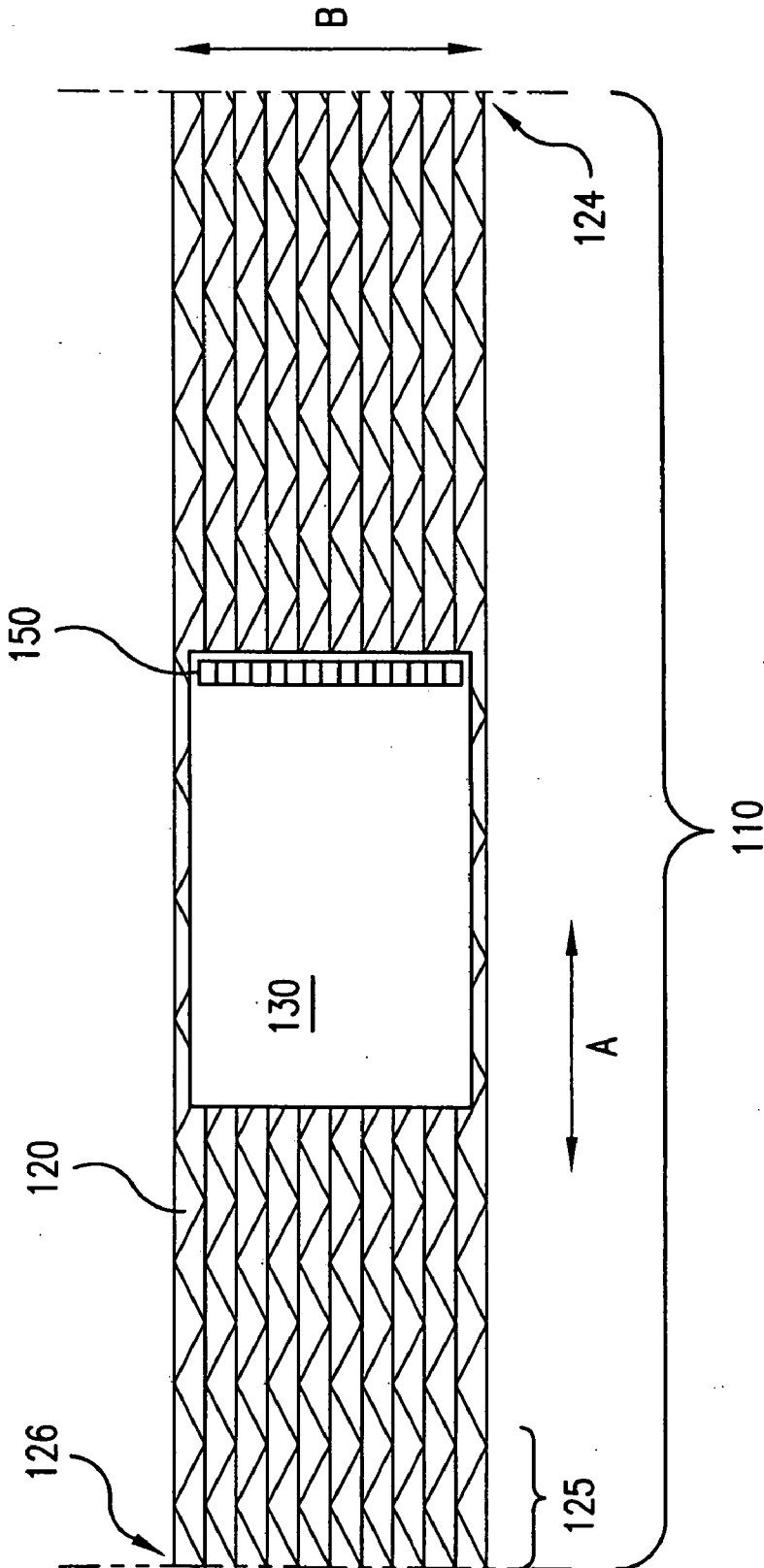

FIG.11A

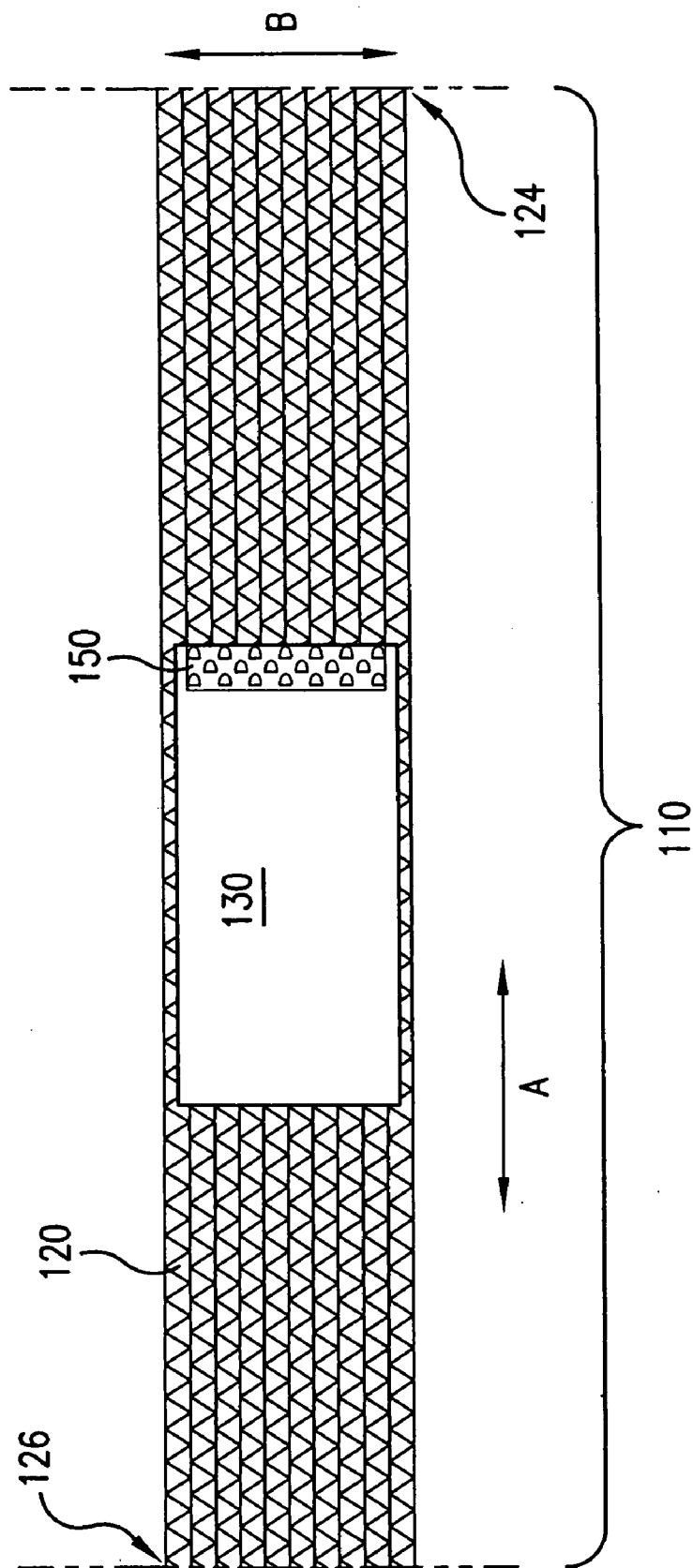

FIG. 11B

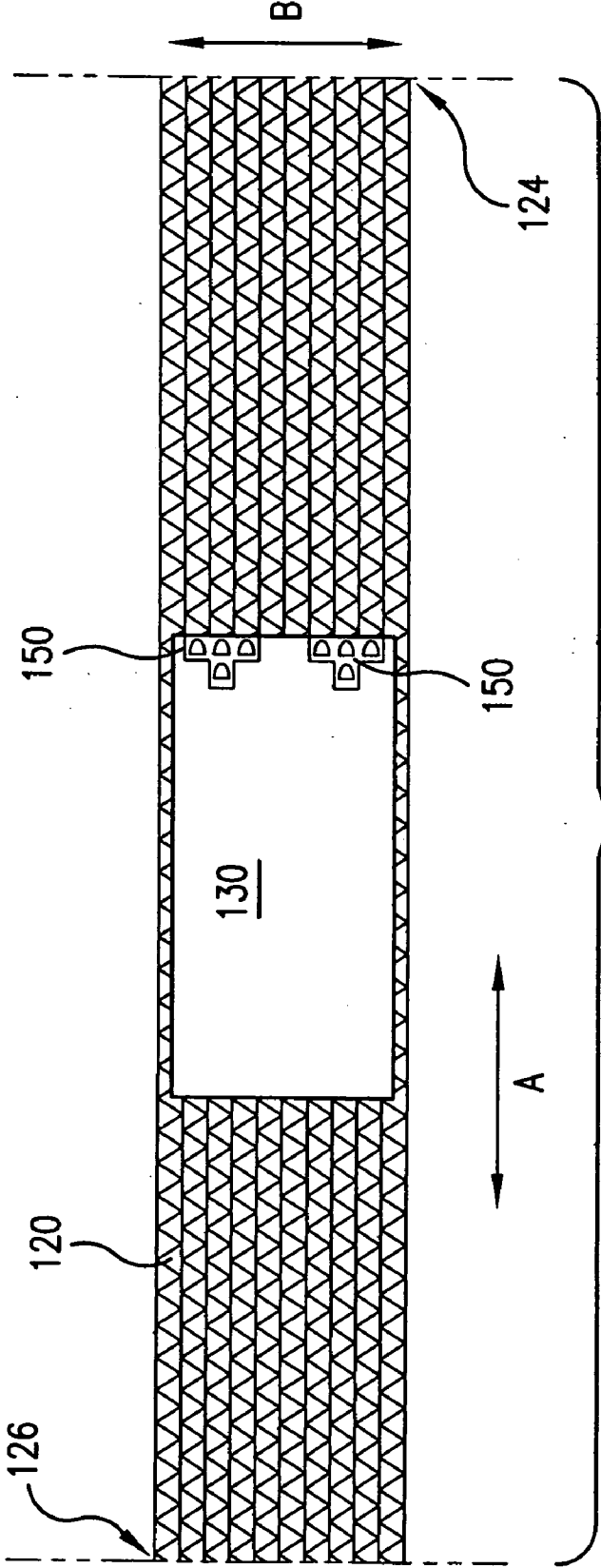

FIG.11C

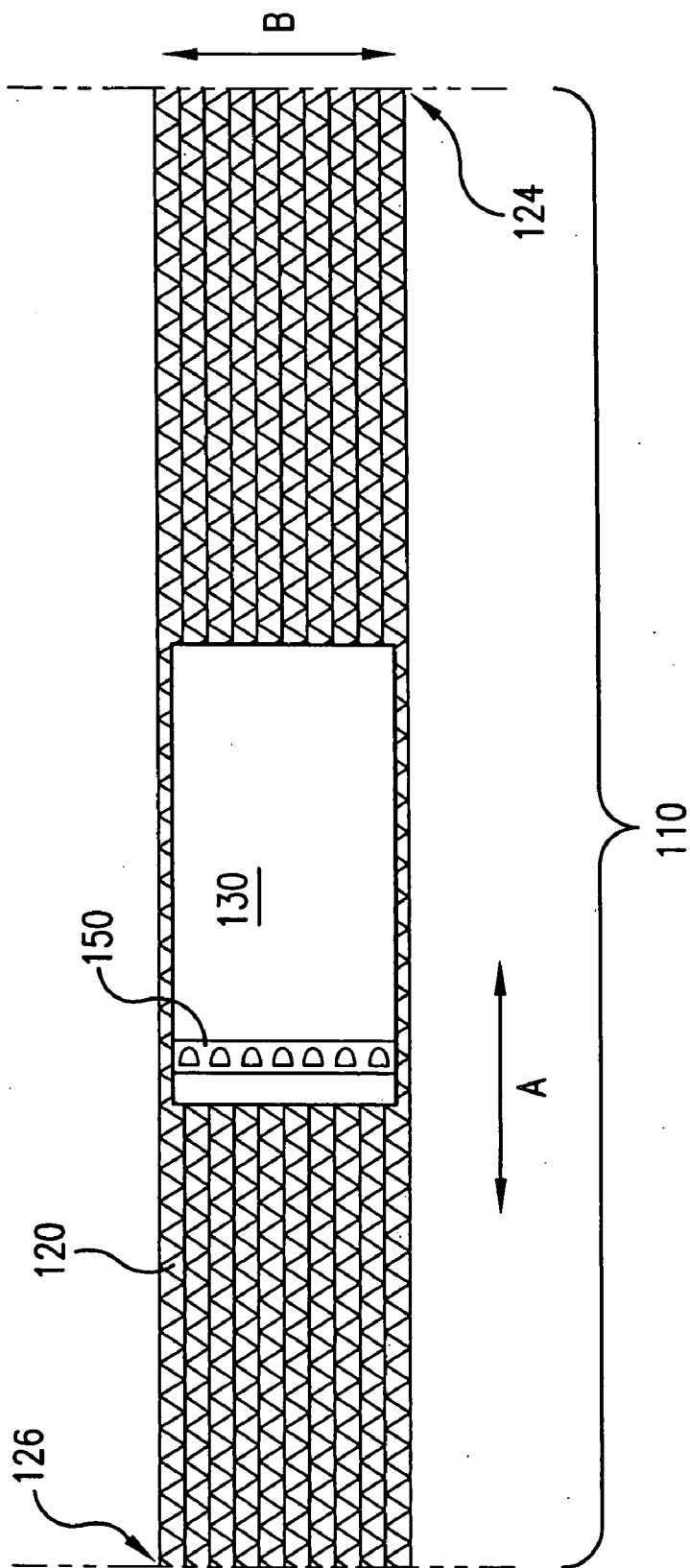

FIG. 11D

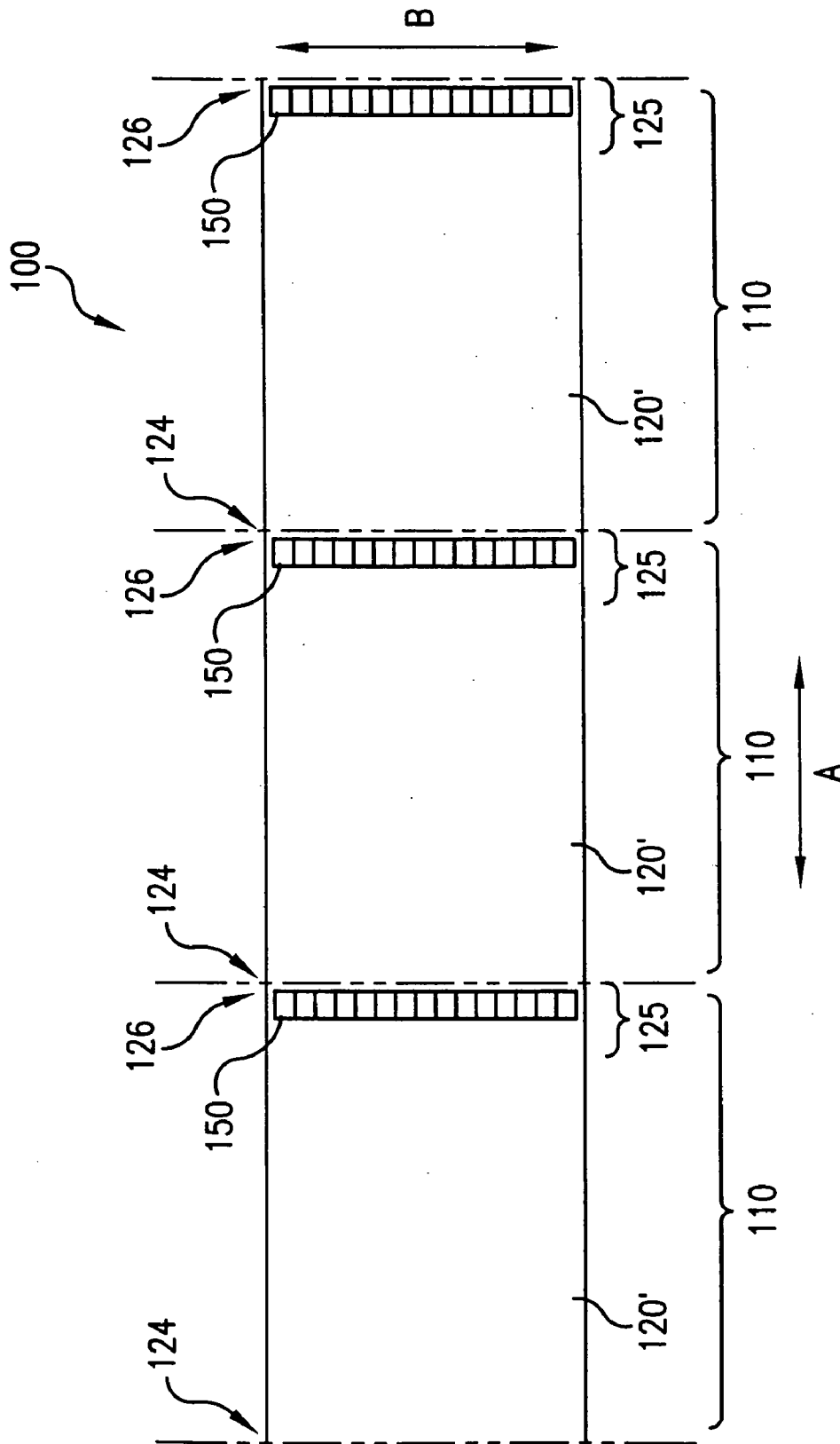

FIG. 12

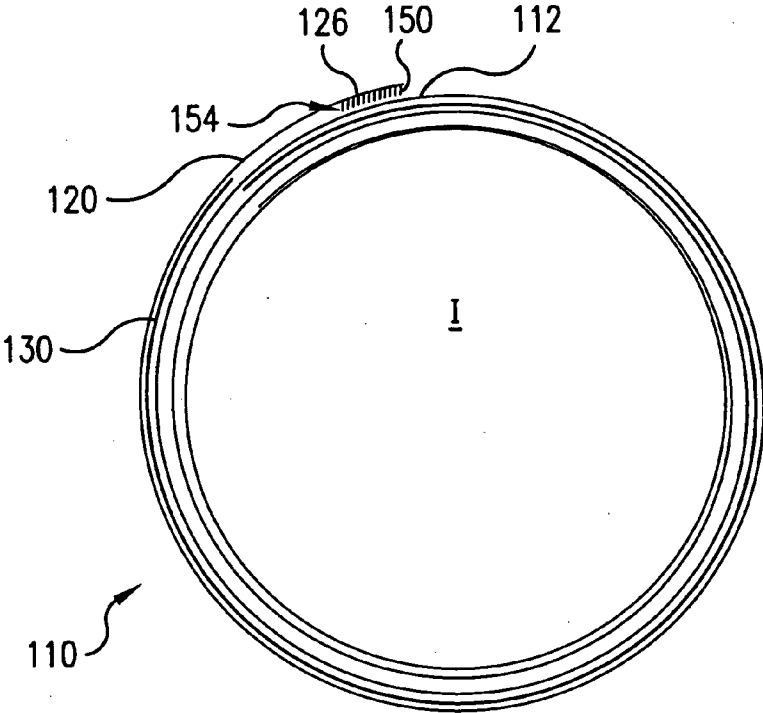

FIG. 13A

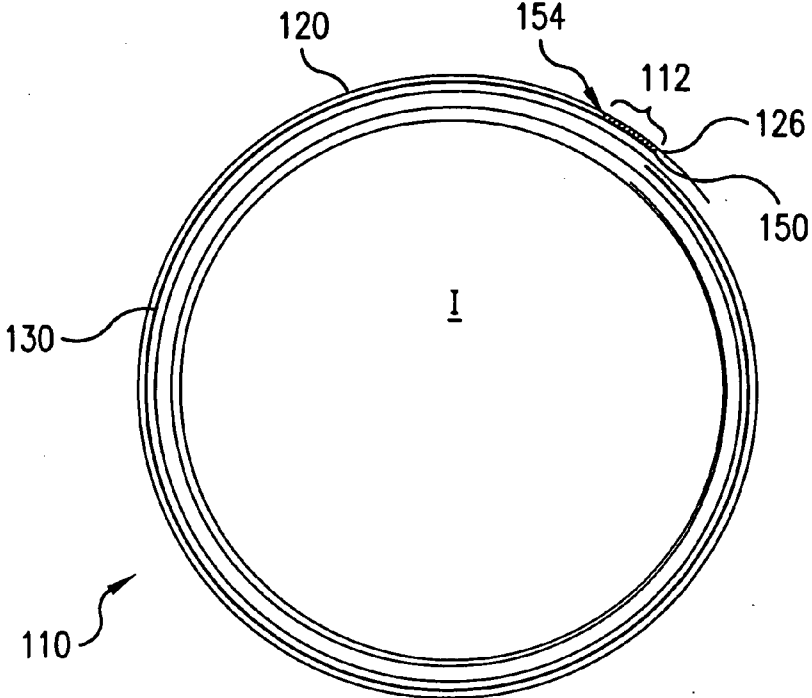

FIG. 13B

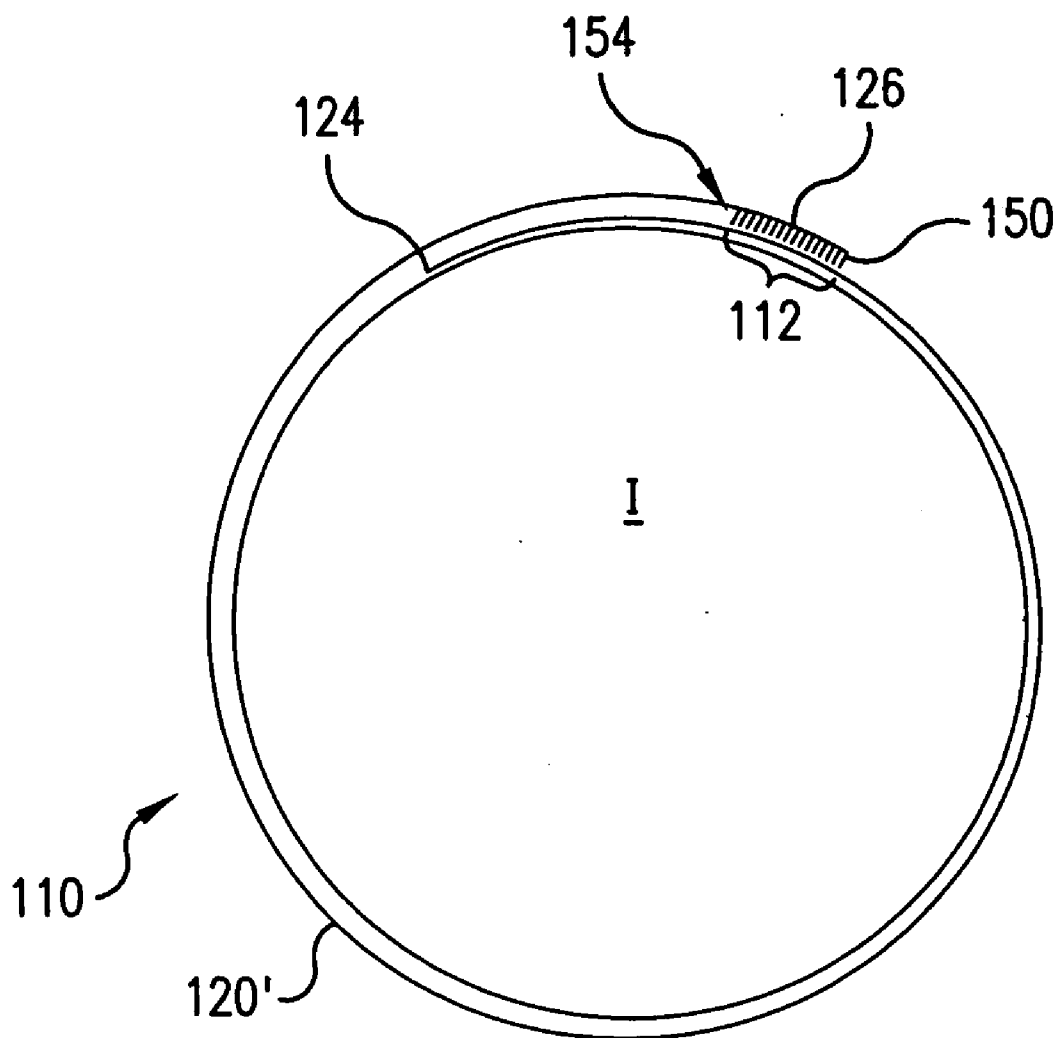

FIG. 13C

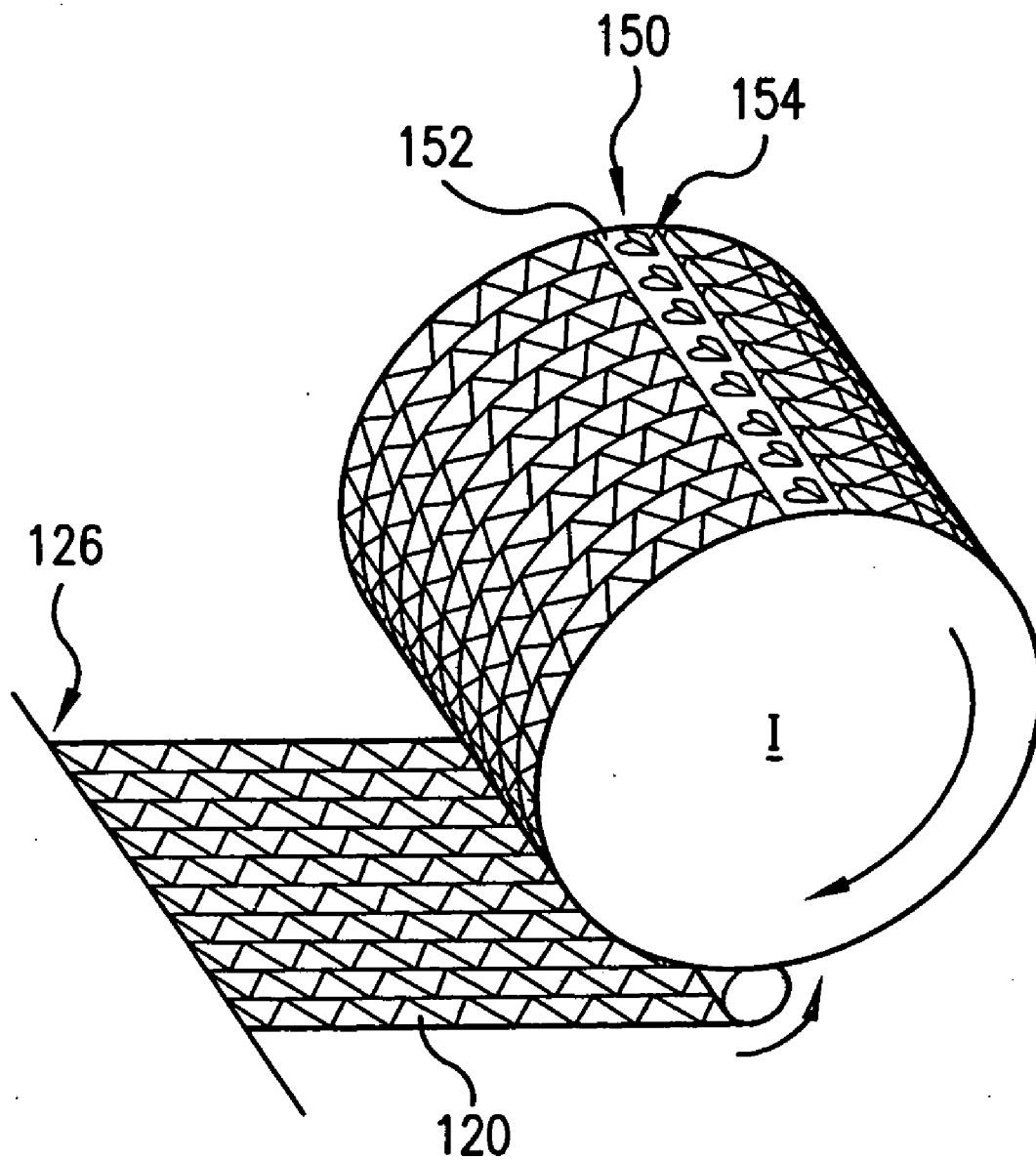

FIG. 13D

WRAPPING MATERIAL WITH FASTENER

CROSS REFERENCE TO RELATED APPLICATIONS

[0001] This application is a divisional of U.S. patent application Ser. No. 11/288,113, filed Nov. 29, 2005, which claims the benefit of U.S. patent application Ser. No. 10/517,172 filed May 1, 2007 as a National Stage entry of PCT/IB2004/003475 filed Oct. 22, 2004, the subject matter of each of the preceding applications, are hereby incorporated by reference in their entirety herein.

FIELD OF THE INVENTION

[0002] The present invention relates to a variety of wrapping materials, and in particular, wrapping materials incorporating a fastener, which secures the tail end of the wrapping material to the fibers of an underlying portion of the wrapping material at the conclusion of a wrapping cycle.

BACKGROUND OF THE INVENTION

[0003] The use of balers for baling agricultural crops into “round” bales (referring to a generally cylindrically shaped bale having a generally round cross-section) has become increasingly common in recent years, replacing the old system of baling square bales that were secured by different types of twine or metal wire. The first round-balers also used various types of twines to secure the bale, however, over the years different types of netting have been used. The use of netting, and in particular, knitted Raschel netting, has become more and more common. Raschel netting is a knitted netting that typically is made from polymeric material and includes a plurality of equally spaced longitudinal ribbons known as “franzes” and a plurality of intervening zigzag ribbons known as “schusses.” However, the netting used, including Raschel knitted netting, is primarily open, with the franzes and schusses only making up a small percentage of the surface area of the bale and does not protect the bales from rain.

[0004] Plastic film wrap, including “sticky film” wrap has been used to wrap whole bales or portions of bales, with the goal of protecting a bale from rain.

[0005] However, the use of impermeable plastic film wrap does not allow moisture already within a baled crop to escape there from, since it is bound by an impermeable plastic layer. Since the inherent moisture level in baled crops may be on the order of one or more dozen percent of weight of the crop (for example, in baled hay), this bound-in humidity easily promotes spoilage of the baled crop.

[0006] Moreover, when such plastic film has been used in existing netting systems, typically only a portion of the bale was covered, leaving part of the circumference unwrapped and exposed to rain and/or to moisture from the ground on which the bale is resting. If the entire bale was wrapped with plastic film, then internal moisture could not escape. Likewise, any excess moisture gained by the crop from exposure to weather also promoted spoilage of the baled crop. Since bales are often left in a field, exposed to weather for a year or more, cumulative rain and/or ground moisture penetration may be significant, as may be the resultant crop spoilage.

[0007] Another disadvantage of using plastic film as a bale wrap has been that the film does not, itself, grasp onto a bale or underlying film layer, and thus a “sticky” portion had to be incorporated to prevent unraveling of the bale. However, use of such sticky film, even if only a small amount, was difficult

to feed into a baler. Reasons for this include that, in the process of loading the film and wrapping a bale, the sticky film stuck to elements of the machine as well, making use of these materials difficult. In order to solve the problem of sticky film sticking to a baling apparatus itself, significant alterations to the baling apparatus had to have been made, often proving not to be cost-effective. The use of VELCRO, or VELCRO-type fasteners for wrapping and closing containers are known, as shown by U.S. Pat. No. 5,732,531 to de Silva et al., EP 0 608 871 A2 to de Silva, and Published UK Patent Application GB 2 221 841 A to Pentith.

[0008] Other known wrapping and closing containers, fasteners, and/or balers are also shown by the following (1) U.S. Pat. Nos. 1,331,367, 1,557,881; 1,452,100; 2,539,725; 3,056,245; 3,120,727; 3,138,841; 3,623,485; 3,654,049; 3,733,769; 3,797,650; 3,816,6700; 4,157,754; 4,318,264; 4,333,602; 4,505,424; 4,556,167; 4,679,851; 4,628,709; 4,703,605; 4,753,182; 4,775,310; 4,901,855; 5,012,631; 5,111,931; 5,152,125; 5,457,855; 6,443,187; 5,732,531; 6,453,805; and 6,425,322, (2) U.S. Patent Application Publication: 2004/0121108, and (3) foreign patent documents: FR 398 606; DE 35 25 294 A1; EP 0 233 471 A1; EP 0 324 577 A1; GB 2 221 841; WO 90/08708; CA 739.282; EP 1 369 516 A1 DE 198 33 554 A1; GB 2 348 633 A; and EP 1 321 028 A1.

SUMMARY OF THE INVENTION

[0009] With the foregoing in mind, the wrapping materials of the present invention provide a solution to the problems noted above in the prior art.

[0010] In accordance with an aspect of the present invention, a fastener, i.e., at least one fastener is attached to a woven or non-woven wrapping material. Upon wrapping an item, each fastener cooperates with fiber elements of an underlying or overlying segment of the wrapping material to engage, lock, hold, or otherwise fasten the wrapping material tightly around the circumference of the item being wrapped with the tail end of the wrapping material being secured to the corresponding overlying or underlying segment of the wrapping material.

[0011] Each fastener preferably includes, for example, a plurality of small “J”, mushroom, or finger shaped engaging elements, although other shapes may be used. Each of these engaging elements include an engaging element body having an engaging element base at one end and terminating at an engaging element free end for engaging, catching, grabbing, locking, holding, or otherwise fastening to the fiber elements of a corresponding underlying or overlying segment of the wrapping material. The engaging element body, from its base to its free end, extends, at angle relative to a fastener base, a length that is sufficient to allow the free end to engage, catch, grab, lock, hold, or otherwise fasten into fibers of the underlying or overlying segment of the wrapping material at the conclusion of a wrapping cycle.

[0012] Each fastener may be positioned anywhere along the length of the wrapping portion that allows each fastener to carry out its intended function. In some embodiments, for example, the fastener may be positioned near the tail end area of each wrapping portion of the wrapping material. In other embodiments the fastener may be positioned near the central region of each wrapping portion of the wrapping material. Still, other embodiments may include the fastener positioned near the leading end or other areas of each wrapping portion of the wrapping material.

[0013] Each fastener may also be positionally oriented on the wrapping material within an angular range of substantially parallel to the length direction of each wrapping portion to substantially transverse to the length direction of each wrapping portion. With these arrangements, a wide variety of continuous and/or discontinuous areas of connection between each fastener and their respective underlying or overlying segment of wrapping material may be realized that would allow fine tuning of the connection force and connection area to specific uses, items to be wrapped, and environmental conditions, just to name a few.

[0014] The wrapping material of the present invention may be fabricated, for example, from at least one continuous wrapping component, which may be in the form of either a continuous, single wrapping component or a continuous, composite wrapping component. The wrapping material of the present invention may also be fabricated from at least one of the aforementioned continuous wrapping components in combination with at least one discontinuous wrapping component, which is different from the continuous component. The wrapping material is preferably provided in roll form and comprises a plurality of end-to-end connected wrapping portions each having at least one fastener associated therewith. Each fastener may be formed, for example, as either a single fastener component or a plurality of co-acting, discontinuous fastener components. The at least one continuous wrapping component is preferably made from a woven or non-woven material and has a width substantially equal to the width of the item to be wrapped and a length sufficient for covering at least the circumference of the item to be wrapped. The at least one discontinuous wrapping component is preferably made from a breathable polymeric material having a width substantially equal to the width of the item being wrapped and a length for covering at least a part of the circumference of the item being wrapped. In embodiments where the wrapping material is fabricated from one of the aforementioned continuous wrapping components and without the discontinuous wrapping component, the continuous wrapping component may, preferably, be made from the same, or similar, breathable polymeric material as the at least one discontinuous wrapping component used in other embodiments.

[0015] The forgoing specific objects and advantages of the invention are illustrative of those that can be achieved by the present invention and are not intended to be exhaustive or limiting of the possible advantages that can be realized. Thus, these and other objects and advantages of this invention will be apparent from the description herein or can be learned from practicing the invention, both as embodied herein or as modified in view of any variation that may be apparent to those skilled in the art.

BRIEF DESCRIPTION OF THE DRAWINGS

[0016] FIGS. 1A and 1B are cross-sectional views of hook-type fasteners according to the present invention;

[0017] FIGS. 1C and 1D are perspective views of the hook-type fastener according to the present invention;

[0018] FIGS. 2A-12 are various top views of the wrapping material in accordance to the present invention;

[0019] FIGS. 13A-C are cross-sectional views of the wrapping material loosely wrapped around the circumference of an item according to various embodiments of the present invention.

[0020] FIG. 13D is a perspective view of the wrapping material during a wrapping cycle according to an embodiment of the present invention.

DETAILED DESCRIPTION OF THE INVENTION

[0021] The invention will now be described with reference to FIGS. 1-13, and the corresponding non-limiting examples. Like reference characters and designations throughout the figures refer to like elements.

[0022] As generally shown throughout FIGS. 2A-13D, the present invention includes a wrapping material 100 having at least one wrapping portion 110 incorporating at least one fastener 150 for securing both the wrapping portion 110 and the tail end 126 thereof in place around a wrapped item I. The wrapping material 100 may form a continuous roll of wrapping material 100 made from a plurality of wrapping portions 110, at least two being shown in FIGS. 2A, 2C, 3A, 3C, 10, and 12. Alternatively, the roll of wrapping material 100 may also be formed from a plurality of wrapping portions 110 connected end-to-end to one another, i.e., either end-to-end as a single continuous web or end-to-end as a plurality of sequential discontinuous segments secured to one another at respective ends.

[0023] Disposed on each of the wrapping portions 110 is at least one fastener 150 in the form of a strip, or a collection of strip segments, such that the continuous roll of wrapping material 100 has a plurality of fasteners 150 serially disposed in an area of each of the plurality of wrapping portions and spaced from one another. Each wrapping portion 110 includes a fastener 150 within that area. As shown in FIGS. 2A-9 and 13A, for example, each fastener 150 may be disposed in the vicinity 125 of the tail end 126 of each wrapping portion 100. Alternatively, as shown in FIGS. 10 and 11A-D, each fastener 150 may also be disposed in an interior region of each wrapping portion 110 that is remote from both the leading end 124 and the tail end 126. With either arrangement, each fastener 150, upon wrapping an item I, will engage, catch, grab, lock, hold, or otherwise fasten into the fiber elements of the underlying or overlying portion 112 of the wrapping portion 110, thereby securing the wrapping portion around the item I as well as the tail end 126 to the underlying or overlying portion 112.

[0024] As shown in FIGS. 1A-1D, each fastener 150 include a fastener base 152 and a plurality of small "J" shaped, or mushroom shaped, or finger shaped engaging elements 154. Each of the plurality of engaging elements 154 are secured to the fastener base 152 at a respective engaging element base 154a. Each engaging element 154 extends away from the fastener base 152, at a general angle .theta. in a range of about 15 degrees to about 90 degrees, relative to the fastener base 152, along at least a portion of an engaging element body 154b at a length L.sub.body. The length L.sub.body of the engaging element 154b, for the embodiments shown in FIGS. 1A-1C, is within a general range of about 0.1 mm to about 10 mm, preferably, in a range of about 0.1 mm to about 1 mm, and more preferably, in a range of about 0.1 mm to about 0.5 mm, and terminating in the free end 154c. The length L.sub.body of the engaging element body 154b, for the embodiment shown in FIG. 1D, is within a general range of about 3 mm to about 20 mm, and more preferably, in a range of about 8 mm to about 12 mm. For the FIG. 1D embodiment, the length L.sub.base of the engaging element base 154a is also in a range of about 3 mm to about 20 mm, and more preferably, in a range of about 8 mm to about 12 mm. With the

embodiment shown in FIGS. 1A-1C, the engaging elements **154** extend from the fastener base **152** generally at an angle of about 90 degrees relative to the fastener base, although the angle θ can vary. With the embodiment shown in FIG. 1D, each of the engaging elements **154**, preferably, extends away from the fastener base **152** at an angle θ , in a range of about 15 degrees to about 45 degrees. The length of the engaging element base **154a** for the embodiments of FIGS. 1A-1C, however, is substantially the thickness, or diameter, of the engaging element body near the fastener base **152**. FIG. 1A shows the engaging elements **154** as a "J" shape. FIGS. 1B and 1C shows the engaging elements **154** as having a mushroom shape. It should be understood that the engaging elements **154** may be of any shape that allows them to sufficiently carry out their intended function of grasping the fiber elements of an underlying or overlying portion **112** of the wrapping material **100** to secure both the wrapping portion **110** around a wrapped item **I** and the tail end **126** to the underlying or overlying portion **112**. Each fastener **150** may be disposed either near the tail end **126** or within an interior region of each wrapping portion **110** of the wrapping material **100** and positioned in any angular orientation relative to either the length direction, shown as arrow **A** in FIGS. 2A-12, of the wrapping material **100** or the width direction, shown as arrow **B** in FIGS. 2A-12, of the wrapping material **100**. Upon completion of a wrapping cycle, a wrapping portion **110**, which is wrapped around the item **I** in a self-overlapping manner, as shown in FIGS. 13A-D, is secured to itself via the engaging, grabbing, locking, or fastening, interaction of the small engaging elements **154** with the fiber elements of a respective underlying or overlying segment **112** of the wrapping portion **110**. The engaging action of the plurality of engaging elements **154** fasten, lock, grab, or otherwise secure the tail end **126** of each wrapping portion **110** securely in place as well as securing the wrapping portion **110**, itself, tightly around the circumference of the wrapped item **I**.

[0025] In the embodiments shown in FIGS. 2A-11D and 13A-13C, the wrapping material **100** is formed as composite wrapping material **100** that includes a continuous netting component **120**, a discontinuous, breathable material component **130**, and at least one fastener **150**. The netting **120** of the wrapping material **100** is preferably woven and may, preferably, take the form of a single continuous web of netting. Ideally, a suitable netting material may be any woven, preferably unraveling resistant, material with sufficient longitudinal (length direction **A**) and lateral (width direction **B**) strength to hold the wrapping material **100** in place around an item to be wrapped, and that allows attachment, via an adhesive or other suitable connection means, of the breathable material panels **130** and the fasteners **150** with minimal difficulty.

[0026] The breathable material **130** may include a non-woven material or film, such as, for example, fused polyethylene material (e.g., Tyvek®), SMS (styrene/alpha-methylstyrene), spun bound materials, melt blown material, micro perforated film, multi-layer breathable sheets, or the like. Each of the breathable material component **130** allow water vapor to escape from the wrapped item, and prevents condensation or moisture from getting to the wrapped item **I** from the outside. The breathable material components **130** may be formed into a plurality of discontinuous panels, though at least two such panels **130** are illustrated in FIGS. 2A, 2C, 3A, 3C, and 10, it should be understood that any number of such panels **130** are adhered to the continuous web of netting **120**

in a substantially repeating pattern throughout its length. The breathable material panels **130** are spaced along the continuous netting material **120** at pre-selected intervals, which relate to a circumference of an item **I** to be wrapped. The overall width of the breathable materials **130** is substantially equal to a width of the item **I** to be wrapped. The breathable panels **130** may be secured to the netting component **120**, via any suitable adhesive, at any desired location. FIGS. 2A-4 show the breathable panels **130** positioned approximately in the central area of each wrapping portion **110**, although the breathable panels **130** may be positioned any where along the length of the wrapping portion **110**. FIGS. 2C and 3C show the breathable panels **130** in an alternative arrangement, in which the breathable panels **130** are positioned near the tail end **126** of each wrapping portion **110** of the wrapping material **100**.

[0027] As shown in FIGS. 2A-6, 10, and 11A-D, each breathable panel **130** may comprise a single sheet of breathable material having various geometrical shapes. The shape of the breathable panel **130**, as shown in FIGS. 2A-4, 10, and 1A-D may be generally rectangular, whereas the breathable panel **130** may also be made in various other shapes, such as, for example, the shapes shown in FIGS. 5 and 6. Further, the breathable panel **130** may also be made from a collection, or plurality, of smaller breathable sub-panels **130'**, such as, for example, the sub-panels **130'** shown in FIGS. 7-9. When wrapped around an item **I**, the sub-panels **130'** of the wrapping portion **110**, collectively co-act with one another to form a breathable panel **130** having a width and length as previously discussed. It should be noted that any of the single panels **130** can be substituted with a plurality of sub-panels **130'** that, which wrapped around an item **I** co-act together to form a single panel. In arrangements utilizing sub-panels **130'**, each fastener **150** used therewith may take the form of the previously described single continuous fastener strip or plurality of discontinuous fastener strip segments, which may also be disposed on either, or both, of the continuous component **120** and/or the discontinuous components **130** and/or **130'** of the composite wrapping material **100**.

[0028] As shown in FIG. 12, the wrapping material **100** is fabricated from a continuous, single or composite wrapping component **120'**, which does not include the use of the discontinuous wrapping components **130**, **130'**, as utilized in the embodiments of FIGS. 2A-11D. In this embodiment, the continuous wrapping component **120'** is formed from either a continuous, single sheet or a plurality of discontinuous sheets secured together end-to-end to form a continuous composite wrapping components **120'**. Regardless of whether the continuous wrapping components **120'** is utilized as a continuous, single wrapping component or a continuous, composite wrapping components, each wrapping portion **110**, nonetheless, includes a fastener **150** in the same manner as previously discussed with respect to the other embodiments or further discussed hereinafter.

[0029] The fasteners **150**, as shown throughout the figures, may be positioned (1) in the vicinity **125** of the trailing end **126**, (2) remote from the leading edge **124** and the trailing edge **126** of each wrapping portion **110**; or (3) in the vicinity of the leading edge **124**. The fastener base **152** of each fastener **150** is secured by any suitable means, such as, for example, an adhesive, to the single continuous component **120'** of the wrapping material **100**, as shown in FIGS. 12 and 13D, or to either one or both of the continuous component **120** and the discontinuous component **130**, or sub-components

130', as shown in FIGS. 2A-11 and 13A-D. Each fastener **150** may also be positionally oriented on the wrapping material **100** within an angular range from substantially parallel to either of the length direction (arrow A) or width direction (arrow B) of the wrapping material **100** to substantially transverse to the length direction (arrow A) or width direction (arrow B) of the wrapping material **100**. With these arrangements, a wide variety of continuous and discontinuous areas of connection between each fastener **150** and the respective underlying or overlying segments **112** of the wrapping material **100** may be realized that would allow for fine tuning of the connection force and connection area to specific uses, items to be wrapped, and environmental conditions, to name a few. As the item I is being wrapped the plurality of engaging elements **154** will mesh, engage, or interact with the fiber elements of any underlying or overlying segment **112** of the wrapping material **100**, thereby locking the tail end **126** in place and securing the wrapping portion **110** around the circumference of the wrapped item I. It should also be noted that when sub-panels **130'** are utilized, a collection of fasteners **150** may also be disposed and positioned thereon in the same manner discussed above.

[0030] FIGS. 13A-C illustrate cross-sectional and perspective views of a wrapped item I in accordance with various embodiments of the invention, which, for the sake of understanding, show wrapping portions **110** loosely wrapped around an item I. FIG. 13D, on the other hand, illustrates a perspective view of a wrapped item I near the end of a wrapping cycle. As shown in FIGS. 13A and 13B, when the breathable material, or discontinuous components, **130** is, or are, mounted on a face of the netting material, or continuous component, **120** is placed against the item I, what is essentially a first layer of netting will contact the item I at a first level. This contacting netting corresponds to a first wrapping layer and may comprise slightly more or less than one complete circumference of a wrapping, as desired, around the item I. Above this layer is the discontinuous breathable material component **130**, **130'** forming a second wrapping layer, and above the second layer a third layer of netting material **120** is formed from a continuation of the same continuous netting material component **120** that formed the first wrapping layer. Each fastener **150**, which has, for example, been attached to either the continuous component **120** or discontinuous component **130**, **130'**, will be pressed into contact, or otherwise interact, with an underlying or overlying segment **112**, as shown in FIGS. 13A and 13B, of the continuous netting material components **120**. It is this contact that allows the plurality of engaging elements **154** of each fastener **150** to engage, catch, grab, lock, hold, or otherwise fasten the fiber elements of the underlying or overlying segment **112** of the wrapping material **100**. The interaction between the plurality of small engaging elements with the fiber elements of the respective underlying or overlying segments **112** allows the fasteners **150** to engage, catch, grab, lock, hold, or otherwise fasten the wrapping material **100**, as a whole, tightly around the wrapped item I with the tail end **126** secured as previously discussed.

[0031] With specific regard to the embodiment shown in FIG. 13D, the wrapping material **100** specifically utilizes the fastener **150** shown in FIG. 1D, the finger-like engaging elements **154** are sufficiently resilient so as to raise above the engaging element base **152** to engage, catch, grab, lock, hold, or otherwise fasten to the fibers of the wrapping material component **110** in place around the item I. As discussed

above, each of finger-like engaging element bodies **154b**, as shown in FIG. 1D, are angled away from the fastener base **152** at an angle θ . in a preferred range of about 15 degrees to about 45 degrees.

[0032] As shown in FIG. 12, the wrapping portion **110** is comprised of the single breathable material **120** that may comprise slightly more than one complete circumference of a wrapping, as desired, around the item I to allow for fastener interaction with an underlying or overlying segment **112**. Each fastener **150**, which has, for example, been attached thereto, preferably in either (1) in the vicinity **125** of the trailing end **126**, as shown in FIGS. 12 and 13D, or (2) remote from the leading edge **124** and the trailing edge **126**, not shown, of each wrapping portion **120'**, will be pressed into contact with an underlying or overlying segment **112** of the single continuous breathable component **120'**. Just as in the composite wrapping material **100** of other embodiments, such contact allows the plurality of engaging elements **154** of each fastener **150** to engage the fiber elements of the underlying or overlying segment **112** of the wrapping material **100**. The interaction between the plurality of engaging elements with the fiber elements of the respective underlying or overlying segments **112**, allows the fasteners **150** to engage, lock, hold, or otherwise fasten the wrapping material **100**, as a whole, tightly around the wrapped item I with the tail end **126** secured as previously discussed.

[0033] It should be emphasized that the wrapping material of the present invention is not limited only to the specific material or specific dimensions, and has applications for preparation of all wrapping material, taking into consideration the desirable qualities of each material and the purposes for which the items are being wrapped.

[0034] Although illustrative embodiments have been described herein in detail, it should be noted and understood that the descriptions and drawings have been provided for purposes of illustration only and that other variations both in form and detail can be added thereupon without departing from the spirit and scope of the invention. The terms and expressions have been used as terms of description and not terms of limitation. There is no limitation to use the terms or expressions to exclude any equivalents of features shown and described or portions thereof.

1. A bale wrapping for use in an automated baling apparatus for the forming and securing of agricultural produce into a substantially cylindrically-shaped bale, said bale wrapping comprising:

a wrapping material having a length dimension at least equal to the circumference of a bale to be wrapped and a width dimension substantially equal to the width dimension of a bale to be wrapped;

wherein, the bale wrapping material:

- (a) is sufficiently liquid impermeable to provide the circumferential extremity of the agricultural produce with a water impervious barrier between the wrapped agricultural produce and bale exterior surface;
- (b) possesses a stiffness sufficient to ensure that the bale wrapping travels intact into and through the automated baling apparatus; and
- (c) possesses sufficient strength to secure and maintain the integrity of the bale.

2. The bale wrapping of claim 1, further comprising a fastener for securing a wrapped bale, said fastener adapted to attach a first portion of the bale wrapping to a second portion of the bale wrapping.

3. The bale wrapping of claim 2, wherein said first portion is a tail portion of the bale wrapping.

4. The bale wrapping of claim 2, wherein said fastener is one of J-shaped and mushroom-shaped.

5. The bale wrapping of claim 1, wherein the agricultural produce is cotton.

6. The bale wrapping of claim 1, wherein said bale wrapping is vapor permeable.

7. The bale wrapping of claim 1, wherein its length is greater than its width.

8. The bale wrapping of claim 1, wherein said bale wrapping is capable of preventing undesirable unraveling after securing the agricultural produce into a substantially cylindrical bale.

9. The bale wrapping of claim 1, further comprising indicators to permit the bale to be seen from a distance.

10. A baled agricultural product in which agricultural produce is formed and secured by a wrapping material, said product comprising:

a wrapping material having a length dimension at least equal to the circumference of the bale and a width dimension substantially equal to the width dimension of the bale;

agricultural produce formed into a substantially cylindrical shape with its circumferential extremity covered by the wrapping material and its two opposite substantially circular sides substantially uncovered by the bale wrapping;

wherein the wrapping material that covers the circumferential extremity of the produce, secures the bale, possesses sufficient strength to maintain the integrity of the bale, maintains the agricultural produce in a compressed state, and provides the circumferential extremity of the agricultural produce with a water impermeable barrier from the exterior surface of the bale wrapping.

11. The baled agricultural product of claim 10, wherein said wrapping material further comprises a fastener for securing the wrapped bale, said fastener adapted to attach a first portion of the wrapping material to a second portion of the wrapping material.

12. The baled agricultural product of claim 11, wherein said first portion of the wrapping material is a tail portion of the wrapping material.

13. The baled agricultural product of claim 11, wherein said fastener is one of J-shaped and mushroom-shaped.

14. The baled agricultural product of claim 10, wherein the agricultural produce is cotton.

15. The baled agricultural product of claim 10, wherein said wrapping material is water impermeable and vapor permeable and said wrapping material provides the circumferential extremity of the agricultural produce with a covering that is water impermeable and vapor permeable.

16. The baled agricultural product of claim 10, wherein said wrapping material secures said agricultural product in part by preventing its undesirable unraveling.

17. The baled agricultural product of claim 10, further comprising indicators to permit the bale to be seen from a distance.

18. The baled agricultural product of claim 10 wherein said wrapping material possesses a stiffness sufficient to ensure that the bale can withstand the operation of an automated baler.

19. A roll of bale wrappings suited for forming and securing agricultural produce into a plurality of substantially cylindrically-shaped bales through the use of an automated baling apparatus, the roll comprising:

a plurality of bale wrapping portions, each bale wrapping portion having a length dimension at least equal to the circumference of each bale to be formed and secured and a width dimension approximately equal to the width of each bale to be formed and secured, said plurality of bale wrapping portions being serially connected and rolled to form said roll;

wherein each bale wrapping portion for covering the circumferential extremity of the agricultural produce is water impermeable to provide the circumferential extremity of the baled produce with a water impermeable barrier from the bale wrapping exterior surface;

and wherein said the bale wrapping portions possess a stiffness sufficient to ensure that each bale wrapping portion travels intact into and through an automated baling apparatus.

20. The roll of bale wrappings of claim 19, wherein each bale wrapping further comprises a fastener for securing a wrapped bale, said fastener adapted to attach a first portion of the bale wrapping to a second portion of the bale wrapping.

21. The roll of bale wrappings of claim 20, wherein said first portion is a tail portion of each of the bale wrappings.

22. The roll of bale wrappings of claim 20, wherein said fasteners are one of J-shaped and mushroom-shaped.

23. The roll of bale wrappings of claim 19, wherein the agricultural produce is cotton.

24. The roll of bale wrappings of claim 19, wherein each of said bale wrapping portions is water impermeable and vapor permeable.

25. The roll of bale wrappings of claim 19, wherein each of said bale wrapping portions secures said agricultural produce in part by preventing undesirable unraveling of the bale wrapping portion.

26. The roll of bale wrappings of claim 19, wherein each bale wrapping portion further comprises indicators to permit the wrapped bale to be seen from a distance.

27. The roll of bale wrappings of claim 19, wherein each of said bale wrapping portions has sufficient longitudinal strength to secure the substantially cylindrically-shaped bale of agricultural produce.

* * * * *