



INTERNATIONAL APPLICATION PUBLISHED UNDER THE PATENT COOPERATION TREATY (PCT)

<p>(51) International Patent Classification ⁶ : B01D 29/11, 46/24, 39/16</p>	<p>A1</p>	<p>(11) International Publication Number: WO 96/36415 (43) International Publication Date: 21 November 1996 (21.11.96)</p>
<p>(21) International Application Number: PCT/US96/06632 (22) International Filing Date: 9 May 1996 (09.05.96) (30) Priority Data: 08/443,635 18 May 1995 (18.05.95) US (71) Applicant: PARKER-HANNIFIN CORPORATION [US/US]; 17325 Euclid Avenue, Cleveland, OH 44112 (US). (72) Inventors: FALL, Ronald, E.; 10125 Gilford Avenue, Indianapolis, IN 46280 (US). JAFARABADI, Mehrdad; 7199 Johnson Court, Brownsburg, IN 46112 (US). RUDDOCK, John, M.; 141 West 161 Street, Westfield, IN 46074 (US). (74) Agent: HUNTER, Christopher, H.; Parker-Hannifin Corporation, 17325 Euclid Avenue, Cleveland, OH 44112 (US).</p>		<p>(81) Designated States: JP, European patent (AT, BE, CH, DE, DK, ES, FI, FR, GB, GR, IE, IT, LU, MC, NL, PT, SE). Published With international search report.</p>

(54) Title: COMPOUND LAYER RESIN BONDED FILTER CARTRIDGE

(57) Abstract

A hollow, cylindrical, resin-bonded filter cartridge (9) has an inner filter media (13) with a graded density which decreases (becomes more porous) in the radial direction from the inner surface (15) to the outer surface (16). An outer strip (14) of filter media is then wound in a spiral or helix around the inner filter media (13). The outer filter media (14) has uniform density and is wound with adjacent windings abutting one another such that a continuous groove or channel (27) is provided along the length of the cartridge (9). The groove or channel (27) provides a greater effective surface area on the outer surface of the filter cartridge. The outer strip (14) of filter media preferably comprises a lengthwise-extending body panel (18) with a pair of leaves (20) extending along either edge of the body panel (18). The leaves (20) are folded against the lower surface (21) of the outer filter media (14) to provide a multi-layer outer filter media structure.

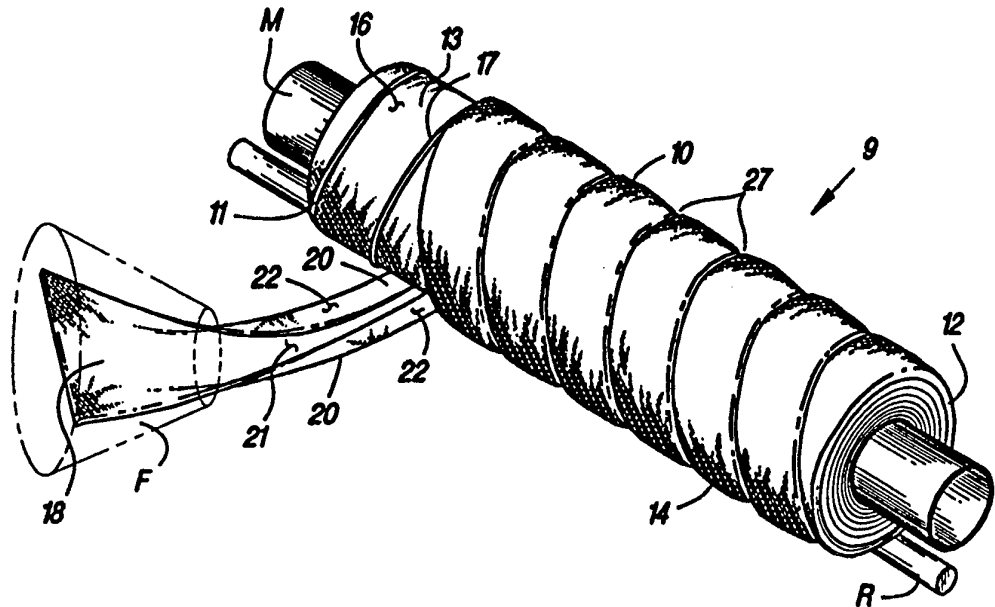

The groove or channel (27) provides a greater effective surface area on the outer surface of the filter cartridge. The outer strip (14) of filter media preferably comprises a lengthwise-extending body panel (18) with a pair of leaves (20) extending along either edge of the body panel (18). The leaves (20) are folded against the lower surface (21) of the outer filter media (14) to provide a multi-layer outer filter media structure.

FOR THE PURPOSES OF INFORMATION ONLY

Codes used to identify States party to the PCT on the front pages of pamphlets publishing international applications under the PCT.

AM	Armenia	GB	United Kingdom	MW	Malawi
AT	Austria	GE	Georgia	MX	Mexico
AU	Australia	GN	Guinea	NE	Niger
BB	Barbados	GR	Greece	NL	Netherlands
BE	Belgium	HU	Hungary	NO	Norway
BF	Burkina Faso	IE	Ireland	NZ	New Zealand
BG	Bulgaria	IT	Italy	PL	Poland
BJ	Benin	JP	Japan	PT	Portugal
BR	Brazil	KE	Kenya	RO	Romania
BY	Belarus	KG	Kyrgystan	RU	Russian Federation
CA	Canada	KP	Democratic People's Republic of Korea	SD	Sudan
CF	Central African Republic	KR	Republic of Korea	SE	Sweden
CG	Congo	KZ	Kazakhstan	SG	Singapore
CH	Switzerland	LI	Liechtenstein	SI	Slovenia
CI	Côte d'Ivoire	LK	Sri Lanka	SK	Slovakia
CM	Cameroon	LR	Liberia	SN	Senegal
CN	China	LT	Lithuania	SZ	Swaziland
CS	Czechoslovakia	LU	Luxembourg	TD	Chad
CZ	Czech Republic	LV	Latvia	TG	Togo
DE	Germany	MC	Monaco	TJ	Tajikistan
DK	Denmark	MD	Republic of Moldova	TT	Trinidad and Tobago
EE	Estonia	MG	Madagascar	UA	Ukraine
ES	Spain	ML	Mali	UG	Uganda
FI	Finland	MN	Mongolia	US	United States of America
FR	France	MR	Mauritania	UZ	Uzbekistan
GA	Gabon			VN	Viet Nam

Title of Invention

**COMPOUND LAYER RESIN
BONDED FILTER CARTRIDGE****FIELD OF THE INVENTION**

5 The present invention relates generally to filter cartridges and methods for making filter cartridges.

BACKGROUND OF THE INVENTION

10 Filter cartridges which are porous, hollow, cylindrical, resin-bonded structures are known in the art for high temperature and/or high strength applications. Particulate matter is entrapped within the pores of the filter media in the cartridge as fluid or gas flows radially inward or radially outward through the media. Various filter media structures have been developed in an attempt to provide an efficient, low-cost and long-lasting filter cartridge. One known filter media structure has a stepped or graded density in the radial direction through the filter cartridge. The density of the filter media increases in the direction of fluid flow (radially inward or radially outward) to trap the larger particulate matter in the more porous (less dense) areas, while the smaller particulate matter is retained in the less porous (more dense) areas. Such filter cartridges are preferable to a single, high density filter cartridge because larger particulate matter contacting the surface of a high density filter may completely plug or fill the small spaces or voids in the media. Such filter media structures are shown in U.S. Patent Nos. 5,122,270; 3,347,391; 4,661,132; 5,269,921; 3,450,632; 4,240,864; 5,340,479; 4,731,184; 4,629,474; 3,399,516; 4,111,815; and 3,347,391.

20 The filter media for such cartridges can be formed in many different ways, for example the media can be blown as fibers onto a spinning mandrel, or the media can be formed in a mat, such as by a needling machine. In the latter case, the mat can be wound around the mandrel in a single winding, or built-up in a number of windings. Harwood, et al., U.S. Patent No.

5,039,413 describes a multi-layer filter cartridge wherein a mat of filter media is wound in a strip around the cartridge such that each individual winding overlaps onto an adjacent winding at least 50% of the width of the wrap. The overlapping of the windings is provided for strengthening the filter cartridge.

5 It is also known to increase the exposed surface area of a filter cartridge by pleating (see e.g., U.S. Patent No. 4,731,184 and U.S. Patent No. 5,252,207) or by cutting into the exterior surface of the filter media so as to form circumferential grooves (see e.g., U.S. Patent No. 3,347,391). Increasing the exposed surface area of a filter cartridge can increase the useful life of the cartridge because the cartridge can collect and retain a larger amount of large particulate matter. The above techniques of pleating and cutting, however, can require additional manufacturing steps which can increase the overall cost of the filter cartridge, while the technique of cutting can also waste material.

10 It is therefore believed that there is a demand in the industry for an efficient, low-cost and long-lasting filter cartridge which i) does not require additional manufacturing steps such as cutting or pleating to increase the exposed surface area of the cartridge, and ii) does not waste material during manufacture.

SUMMARY OF THE INVENTION

The present invention provides a novel and unique structure for an efficient, low-cost and long-lasting filter cartridge, and a method for making the filter cartridge.

20 The filter cartridge includes an inner, tubular, depth-type filter media preferably formed from needled mat material. The inner filter media is impregnated with a resin for strength and is wound around a mandrel in a plurality of windings to an appropriate diameter. The wound mat of inner filter media has a density which decreases (becomes more porous) in the radial direction from the inner surface to the outer surface. The density of the inner filter media can be controlled by compression rollers as the inner filter media is being wound around the mandrel. A polyester

wire or string can be wound around the inner filter media to retain the inner filter media on the mandrel.

An outer filter media is then disposed around the inner filter media. The outer filter media is preferably a needled-fibrous mat material in strip or ribbon form. The outer strip of filter media preferably has a uniform density which is significantly greater (more porous) than the inner filter media such that the outer filter media acts as a pre-filter. The outer filter media is also preferably formed with a lengthwise-extending body panel and a pair of leaves extending along either edge of the panel. The leaves are folded against the lower (inner) surface of the outer filter media to provide a multi-layer outer filter media structure.

The outer filter media is spirally or helically wrapped around the inner filter media. The outer filter media is preferably wrapped in a single layer around the inner filter media such that the edges of adjacent windings abut each other. A continuous groove or channel is provided between the adjacent windings of the outer filter media because of the multi-layered structure of the outer filter media. The groove or channel provides a greater effective surface area for particle entrapment along the length of the filter cartridge. The ends of outer layer of filter media can be secured to the inner filter media in an appropriate manner, for example with an adhesive.

The present invention as described above provides an efficient, low-cost and long-lasting filter cartridge which does not require additional manufacturing steps (such as pleating or cutting) to increase the exposed surface area of the cartridge, and does not waste material during manufacture.

Other features and advantages of the present invention will become further apparent upon reviewing the following description and accompanying drawings.

BRIEF DESCRIPTION OF THE DRAWINGS

Figure 1 is a perspective view of a filter cartridge constructed according to the principles of the present invention;

4

Figure 2 is an end view of the filter cartridge of Figure 1;

Figure 3 is a partially assembled view of the filter cartridge of Figure 1; and

Figure 4 is a sectional view of the filter cartridge of Figure 1 taken substantially along the plane described by the lines 4-4 of Figure 1; and

5 Figure 5 is a schematic illustration of the method for manufacturing the filter cartridge of Figure 1.

DETAILED DESCRIPTION OF THE PREFERRED EMBODIMENT

10 Referring to the drawings, and initially to Figures 1-4, a filter cartridge constructed according to the principles of the present invention is indicated generally at 9. The filter cartridge 9 has a tubular or cylindrical body 10 with opposite flat end faces 11, 12. The dimensions of the filter cartridge (inner and outer diameter, length, etc.) can vary depending upon the particular application as should be apparent to those skilled in the art upon reading the following description of the invention.

15 The filter cartridge 9 includes an inner filter media wrap 13 and an outer filter media wrap 14. As can best be seen in Figure 2, the inner filter media 13 is a depth-type filter media such that particles are retained throughout the thickness of the media. The inner filter media has a graded density which varies from the inner surface 15 to the outer surface 16 of the inner media. Preferably, the inner filter media has a density which is greater (less porous) toward the inner surface and is less (more porous) toward the outer surface. The density of the inner filter media
20 preferably varies in a uniform manner radially outward from the inner surface to the outer surface, although the variation in density can be tailored for the particular application (e.g., the density can be stepped, exponential, etc.).

25 The inner filter media 13 is preferably formed from a conventional material. One preferred material for the inner filter media is an acrylic, however, other appropriate materials include polymers, such as polyester, polyamide, polyvinyl chloride or polyacrylonitrile; or

polyolefins such as polyethylene or polypropylene. Other less preferred materials include wool, esparto, yucca, cellulose, glass, rayon or admixtures thereof. Methods for manufacturing the inner filter media material into an appropriate porous structure are also conventional and well-known to those skilled in the art. One preferred method is to form a needled-fibrous mat of material. The mat can be formed by a needling machine which weaves the fibers into a matrix.

The inner filter media is preferably impregnated with a heat-fusible resin to impart strength and rigidity to the media such that the media can withstand high temperatures and pressures, and to waterproof the fibers. The resin employed in the inner filter media is also conventional, and can be a thermosetting resin such as water-based phenol formaldehyde condensation products, urea formaldehyde condensation products, or melamine resins. Thermoplastic resins such as polystyrene may also be used. The methods for impregnating fibers with resin are also conventional and well-known to those skilled in the art. One preferred method of impregnating the inner filter media is to pass the mat through a pair of transfer rollers in a nip coater, although another appropriate method is to dip-coat the mat. The inner filter media is then located in a pre-cure oven until the inner filter media has a relatively stable form, but has a certain amount of flexibility.

The mat is then cut to an appropriate length and wound around a mandrel "M" (Fig. 3) by automated machinery into a multi-layer tubular form. Preferably, three outside compression rollers are used to direct the mat around the mandrel. The rollers vary the density in the mat and control the diameter of the inner filter media by varying the compression on the mat. As indicated previously, the rollers preferably provide a wound mat with a density which is maximum at the inner surface and decreases (becomes more porous) radially outward from the inner surface to the outer surface. The number of layers of inner filter media wound around the mandrel can vary depending upon the initial thickness of the inner filter media, the amount of compression provided by the rollers on the mat, and the desired overall diameter of the filter cartridge.

After the inner filter media is wound onto the mandrel, a string or wire 17 (e.g., a polyester or acrylic tire cord) can be wrapped around the inner filter media to hold it temporarily on the mandrel. Alternatively, adhesive can be applied along the free edges of the inner filter media to hold the inner filter media together.

5 The outer filter media wrap 14 is then disposed around the inner filter media 13. The outer filter media can also be formed of the same needled-fibrous mat material as the inner filter media, and can be resin impregnated in the same manner as described previously. Preferably the density (porosity) of the outer filter media is uniform and is significantly greater than the density of the inner filter media. As an example, the density of the inner filter media might vary from
10 about $5\mu\text{m}$ at the inside diameter to $75\mu\text{m}$ at the outside diameter, while the density of the outer filter media layer might be at least $125\mu\text{m}$. The outer filter media thereby is designed to act as a pre-filter for the inner filter media. As with the inner filter media, the density of the outer filter media can be chosen depending upon the particular application.

 The outer filter media preferably comprises a lengthwise-extending body panel 18 having
15 a pair of leaves 20 along either edge of the body panel. The leaves 20 are folded lengthwise against the inner (lower) surface 21 of the main body panel 18 to create a strip or ribbon form. Preferably, the leaves 20 of the outer filter media are each about half the width of the main body panel 18 such that when the leaves are folded inwardly, an outer filter media structure is provided with substantially two complete layers (see e.g., Figure 4). The leaves can be folded as the outer
20 filter media layer is disposed around the inner filter media layer such as by feeding the outer filter media through a funnel "F" to impart a C-shaped form to the strip.

 Preferably, the outer filter media 14 is wound in a helical or spiral fashion in a single layer along the length of the cartridge, as illustrated in Figure 3. Winding equipment (e.g., funnel F) is positioned substantially perpendicular to the axis of the mandrel and traverses the length of the cartridge in a single pass. A roller "R" then compresses the strip of outer filter media as it is being
25 applied to the inner filter media to provide a substantially flat outer filter media structure. When

the outer filter media is wrapped around the inner filter media, the inwardly-directed surface 22 of the leaves 20 is in surface-to-surface contact with the outer surface 16 of the inner filter media 12. The ends of the outer filter media strip can then be secured to the inner filter media such as by a hot melt adhesive or other appropriate means.

5 The outer filter media is wound in such a manner that the edges of the individual windings abut each other along the length of the filter cartridges, as best shown in Figure 4. In so doing, a thin V or U-shaped groove or channel 27 is provided between the individual windings continuously along the length of the filter cartridge at the interface locations between the windings. The groove or channel 27 is caused by the rounded edge structure of each winding formed as a
10 result of the multi-layered outer filter media structure. The groove or channel extends part-way through the outer filter media structure. Alternatively, the outer filter media can be wound in such a manner that a space is provided between adjacent windings and the groove or channel exposes the inner filter media 12. In either case, the groove or channel provides a greater effective surface
15 area on the exterior surface of the cartridge.

15 The filter cartridge is then given a final cure to set the resin in the inner and outer filter media. The final cure also causes the windings of the outer filter media (if they are abutting each other) to adhere to one another along their side edges to form a strong integral outer layer. The cartridge is then removed from the mandrel and sheared or cut to an appropriate length, if
20 necessary, to provide the flat end surfaces.

20 A schematic illustration of a portion of the machinery for forming the filter cartridge of the present invention is shown in Figure 5. The inner filter media is provided in mat form on roll
25 30, and passed through a cutter/splicer 32 and resin-coater 34. The resin-impregnated mat is then pre-cured in oven 36 and cut to an appropriate length by cutter 38. The cut mat is then fed through a mat winder 40 and wound around a mandrel 41 to an appropriate diameter. Mat winder
30 40 can introduce a wire or string to hold the inner filter media on the mandrel.

After the inner filter media 13 is wound around mandrel 41, the strip of outer filter media 14 is unwound from roll 42 and fed through winding equipment 49 (e.g., the funnel) to wrap the inner filter media on the mandrel. The funnel traverses the length of the filter cartridge as it applies the spiral or helical winding of outer filter media material. The outer filter media is then cut as appropriate and attached (such as with adhesive) at its ends to the inner filter media. The filter cartridge is then removed from the mandrel, cut to an appropriate length, and given a final cure.

The filter cartridge described above provides a greater effective surface area along the outer surface of the filter cartridge by virtue of the exterior channel or groove along the windings on the cartridge. Fluid flowing through the cartridge is generally drawn to the groove or channel because of the less flow resistance in this area. As the filter media in the groove or channel becomes filled with particulate matter, the fluid begins to flow primarily through the body portion of the outer filter media. The increased surface area on the cartridge increases the service life of the cartridge and is provided without additional manufacturing steps such as pleating or cutting, and without wasting outer filter media material. Further, the outer filter media, being of a larger porous structure, traps larger particulate matter, which thereby also extends the life of the filter cartridge. The wrapping of the inner filter media with a spiral or helical layer of outer filter media further improves the strength of the filter cartridge by tightly retaining the layers of the filter cartridge. The diameter of the filter cartridge can also be carefully controlled by compression rollers such that post-grinding of the cartridge is not necessary.

The assembled filter cartridge described above can then be further integrated into a filter assembly. The structure of the filter assembly can vary depending upon the particular application, and is not described herein for sake of brevity. As should be apparent from the above, the filter cartridge of the present invention is intended to be used where the contaminated fluid or gas passes radially inward through the filter cartridge to take advantage of the porous structure of the outer

pre-filtration layer, the increased filter area provided by the continuous groove or channel in the outer layer, and the varying density in the inner filter media.

Thus, described above, the present invention provides an efficient, low-cost and long-lasting filter cartridge which does not require additional manufacturing steps to increase the exposed surface area, and which does not waste material during manufacture. The principles, preferred embodiments and modes of operation of the present invention have been described in the foregoing specification. The invention which is intended to be protected herein should not, however, be construed as limited to the particular form described as it is to be regarded as illustrative rather than restrictive. Variations and changes may be made by those skilled in the art without departing from the scope and spirit of the invention as set forth in the appended claims.

CLAIMS**WHAT IS CLAIMED IS:**

- 1 1. A hollow cylindrical filter cartridge 9 characterized as having an inner wrap 13 of depth
2 filter media and an outer wrap 14 of filter media in the form of a strip 18 surrounding the inner
3 wrap of filter media in a plurality of spiral or helical windings, said plurality of windings of said
4 strip 18 defining a groove or channel 27 along the exterior of the cartridge which increases the
5 overall surface area of the filter cartridge 9.

- 1 2. The cartridge as in claim 1, characterized in that said outer wrap 14 of filter media is
2 wrapped with adjacent windings of said strip abutting each other along the edges of the windings,
3 and said groove or channel 27 extends continuously along the length of the cartridge.

- 1 3. The cartridge as in claim 2, characterized in that said inner wrap 13 of filter media has
2 an outer surface 16, and said outer wrap 14 of filter media has an inner surface 22, and said inner
3 surface 22 of said outer wrap 14 of filter media is disposed in surface-to-surface contact with said
4 outer surface 16 of said inner wrap 13 of filter media around the entire circumference of the
5 cartridge 9.

- 1 4. The cartridge as in claim 3, characterized in that said inner wrap 13 of filter media is
2 formed from fibrous mat material with a density which varies from an inner surface 15 to the outer
3 surface 16 across the thickness of the inner wrap 13.

- 1 5. The cartridge as in claim 4, characterized in that said outer wrap 13 of filter media is also
2 formed from fibrous mat material and has a generally uniform density throughout the thickness of
3 the outer wrap.

4 6. The cartridge as in claim 5, characterized in that said outer wrap 13 of filter media is
5 formed from fibrous mat material with a density which is less than the minimum density of the
6 inner filter media wrap 13.

1 7. The cartridge as in claim 1, further characterized as having a string or wire 17 tightly
2 surrounding said inner wrap 13 and retaining said inner wrap 13 in tubular form.

1 8. The cartridge as in claim 1, further characterized in that the outer wrap 14 of filter media
2 has a main body panel 18 and a pair of leaves 20 along either edge of the main body panel 18, each
3 of said leaves 20 being folded lengthwise against a surface 21 of the main body panel 18 such that
4 the outer wrap 14 is a multi-layered structure.

1 9. A hollow cylindrical filter cartridge 9 having an inner wrap 13 of filter media in the form
2 of a tube and an outer wrap 14 of filter media surrounding the inner wrap of filter media,
3 characterized in that said outer wrap 14 of filter material extends in a helical or spiral winding
4 along the length of the inner filter media 13 and said outer wrap 14 of filter media has a
5 lengthwise-extending main body panel 18 with an integral leaf 20 extending lengthwise along at
6 least one edge of the main body panel 18, said leaf 20 being folded lengthwise against a surface
7 21 of the main body panel 18 to form a multi-layered structure.

1 10. The cartridge as in claim 9, characterized in that a first leaf 20 extends along a first edge
2 of the main body panel 18 and is folded lengthwise against the surface 21, a second leaf 20 extends
3 along a second edge of the main body panel 18 and is also folded lengthwise against the surface
4 21, and each of said leaves 20 has a width which is about half the width of the main body panel
5 18.

1 11. A method for forming a hollow cylindrical filter cartridge 9, characterized as including
2 the steps of:

- 3 i) providing an inner wrap 13 of depth filter media in tubular form, and
4 ii) wrapping a strip of an outer filter media 14 around the inner filter media 13, said outer
5 filter media 13 being wrapped such that a groove or channel 27 is provided between adjacent
6 windings of the strip to provide increased surface area on the exterior of the filter cartridge 9.

1 12. The method as in claim 11, characterized in that said outer filter media 14 is spirally or
2 helically wrapped in a single layer around the inner filter media 13 such that the groove or channel
3 27 is provided continuously along the length of the filter cartridge.

1 13. The method as in claim 12, characterized in that said outer filter media 14 is wrapped such
2 that the edges of adjacent windings abut one another.

1 14. The method as in claim 13, characterized in that the inner wrap 13 is wrapped around a
2 mandrel "M" and the density of the inner wrap 13 is at a maximum along the mandrel and
3 decreases radially outward away from the mandrel.

1 15. The method as in claim 14, characterized in that the inner wrap 13 is compressed by rollers
2 "R" around the mandrel "M" as the inner wrap 13 is being wrapped so as to increase the porosity
3 of the inner wrap 13 in the radially outward direction.

1 16. The method as in claim 11, characterized in that the outer wrap 14 of filter media is in the
2 form of a strip with a main body panel 18 and a pair of leaves 20 along either edge of the body
3 panel, and that said leaves are folded lengthwise against a surface 21 of the main body panel 18
4 to form a multi-layered structure as the outer filter media 14 is wrapped around the inner filter
5 media 13.

1 17. The method as in claim 11, characterized in that a string or wire 17 is wrapped tightly
2 around said inner filter media 13 to retain said inner filter media 13 in tubular form.

1/2

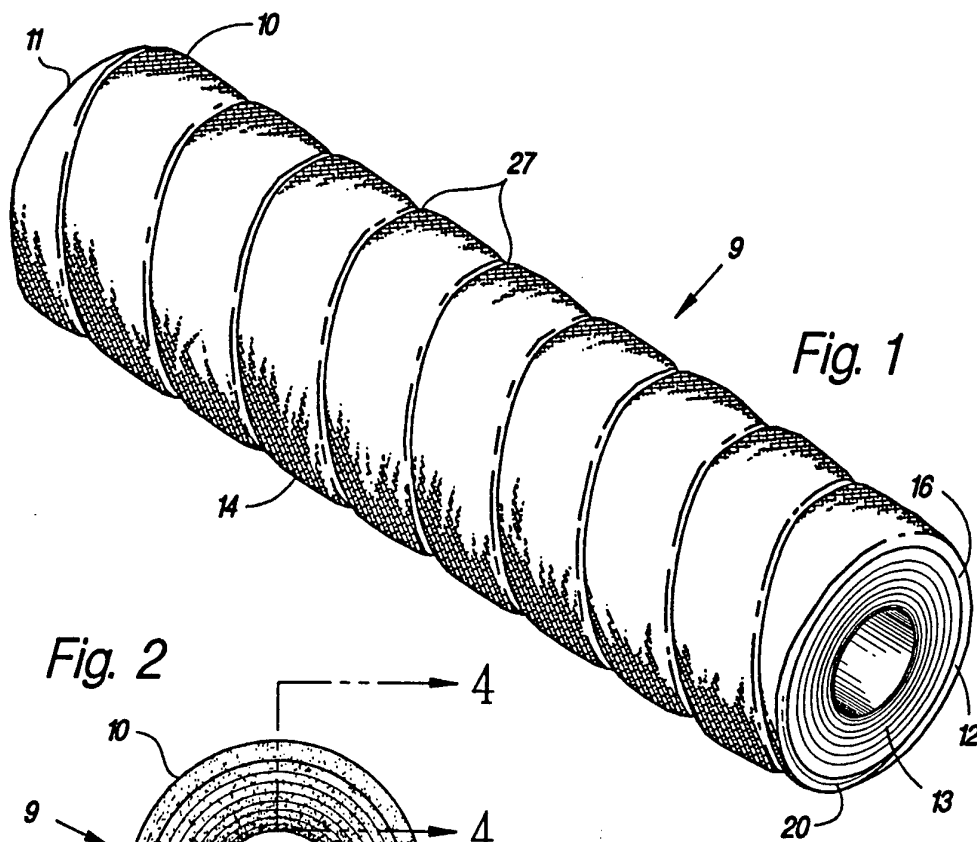

Fig. 1

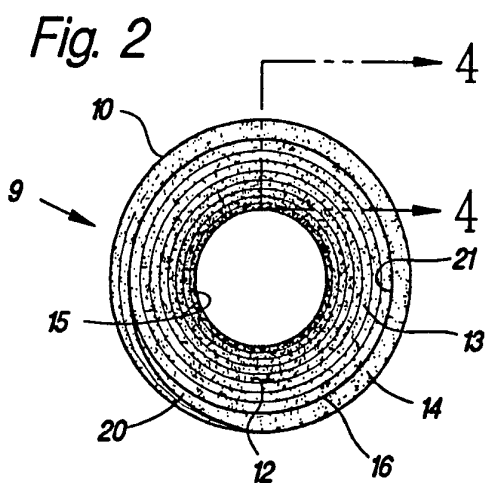

Fig. 2

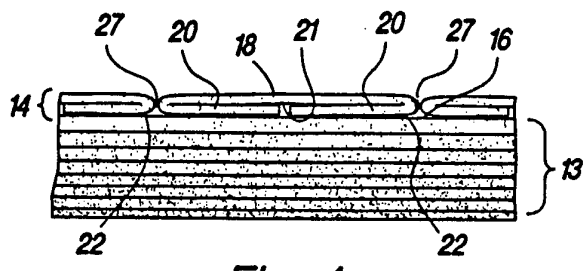

Fig. 4

2/2

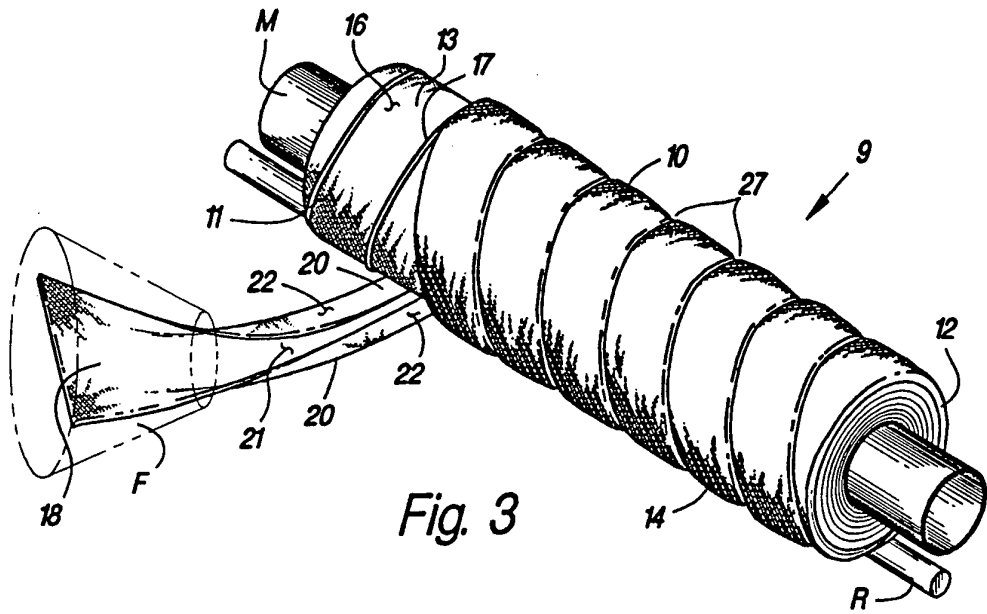

Fig. 3

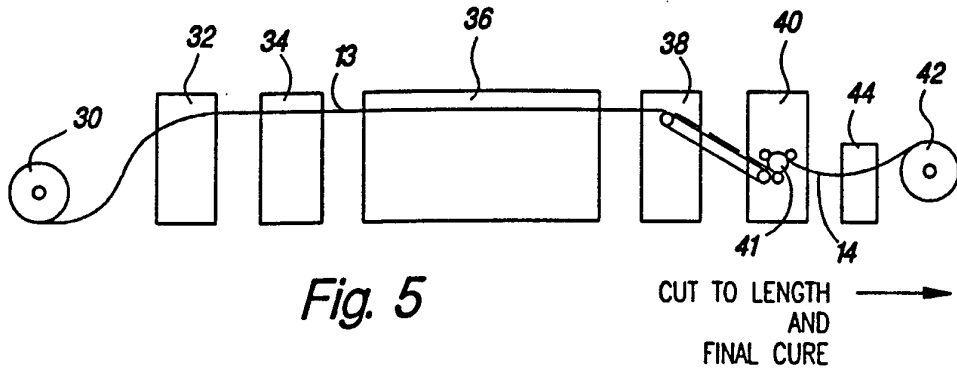

Fig. 5

CUT TO LENGTH
AND
FINAL CURE

INTERNATIONAL SEARCH REPORT

International Application No

PCT/US 96/06632

A. CLASSIFICATION OF SUBJECT MATTER
 IPC 6 B01D29/11 B01D46/24 B01D39/16

According to International Patent Classification (IPC) or to both national classification and IPC

B. FIELDS SEARCHED

Minimum documentation searched (classification system followed by classification symbols)

IPC 6 B01D

Documentation searched other than minimum documentation to the extent that such documents are included in the fields searched

Electronic data base consulted during the international search (name of data base and, where practical, search terms used)

C. DOCUMENTS CONSIDERED TO BE RELEVANT

Category *	Citation of document, with indication, where appropriate, of the relevant passages	Relevant to claim No.
A	GB,A,2 267 656 (PALL CORPORATION) 15 December 1993 see page 8, line 31 - line 36; claims 1-6,16-19 ---	1
A	DE,U,92 07 015 (SEITZ-FILTER-WERKE GMBH & CO) 1 October 1992 see page 18; figures ---	1
A	EP,A,0 458 049 (LACO S.A.) 27 November 1991 see figures ---	1
A	PATENT ABSTRACTS OF JAPAN vol. 94, no. 010 & JP,A,06 297605 (MIYAGAWA ROLLER KK), 25 October 1994, see abstract -----	1

Further documents are listed in the continuation of box C.

Patent family members are listed in annex.

* Special categories of cited documents :

- *A* document defining the general state of the art which is not considered to be of particular relevance
- *E* earlier document but published on or after the international filing date
- *L* document which may throw doubts on priority claim(s) or which is cited to establish the publication date of another citation or other special reason (as specified)
- *O* document referring to an oral disclosure, use, exhibition or other means
- *P* document published prior to the international filing date but later than the priority date claimed

- *T* later document published after the international filing date or priority date and not in conflict with the application but cited to understand the principle or theory underlying the invention
- *X* document of particular relevance; the claimed invention cannot be considered novel or cannot be considered to involve an inventive step when the document is taken alone
- *Y* document of particular relevance; the claimed invention cannot be considered to involve an inventive step when the document is combined with one or more other such documents, such combination being obvious to a person skilled in the art.
- *&* document member of the same patent family

Date of the actual completion of the international search

5 August 1996

Date of mailing of the international search report

- 9. 08. 96

Name and mailing address of the ISA

European Patent Office, P.B. 5818 Patentlaan 2
 NL - 2280 HV Rijswijk
 Tel. (+ 31-70) 340-2040, Tx. 31 651 epo nl,
 Fax (+ 31-70) 340-3016

Authorized officer

Van Belleghem, W

INTERNATIONAL SEARCH REPORT

Information on patent family members

International Application No

PCT/US 96/06632

Patent document cited in search report	Publication date	Patent family member(s)	Publication date
GB-A-2267656	15-12-93	US-A- 5290446	01-03-94
		CA-A, C 2076158	11-12-93
		CN-A- 1087024	25-05-94
		DE-A- 4319261	16-12-93
		FR-A- 2692163	17-12-93
		IT-B- 1260657	22-04-96
		JP-A- 6063316	08-03-94

DE-U-9207015	20-08-92	NONE	

EP-A-458049	27-11-91	DE-A- 4016743	28-11-91
		DE-A- 4030844	09-04-92
		JP-A- 5133497	28-05-93
