



US00D987566S

(12) **United States Design Patent**  
**Zhang et al.**

(10) **Patent No.:** **US D987,566 S**

(45) **Date of Patent:** **\*\* May 30, 2023**

(54) **BASE STATION FOR CLEANING ROBOT**

D867,987 S \* 11/2019 Mi ..... D13/108  
D897,949 S \* 10/2020 Pearce ..... D13/108  
D908,993 S \* 1/2021 Li ..... D32/31

(Continued)

(71) Applicant: **BEIJING XIAOMI MOBILE SOFTWARE CO., LTD.**, Beijing (CN)

(72) Inventors: **Lei Zhang**, Beijing (CN); **Chunyang Dou**, Beijing (CN); **Guangsheng Zhang**, Beijing (CN)

**FOREIGN PATENT DOCUMENTS**

CN 305054031 S 3/2019  
CN 306098532 S 10/2020  
JP 1698204 S 10/2021

(73) Assignee: **BEIJING XIAOMI MOBILE SOFTWARE CO., LTD.**, Beijing (CN)

**OTHER PUBLICATIONS**

(\*\*) Term: **15 Years**

“Shark Robot”. Found online Jan. 10, 2022 at amazon.com. Reference dated Nov. 17, 2019. Retrieved from [https://www.amazon.com/Shark-R1001AE-Self-Empty-Connected-Capacity/dp/B07S864GPW/ref=asc\\_df\\_B07S864GPW/?th=1](https://www.amazon.com/Shark-R1001AE-Self-Empty-Connected-Capacity/dp/B07S864GPW/ref=asc_df_B07S864GPW/?th=1). (Year: 2019).\*

(Continued)

(21) Appl. No.: **35/512,957**

(22) Filed: **Aug. 6, 2021**

*Primary Examiner* — Kendra Leslie Hamilton  
*Assistant Examiner* — Amanda Christensen  
(74) *Attorney, Agent, or Firm* — Amster, Rothstein & Ebenstein LLP

(80) **Hague Agreement Data**

Int. Filing Date: **Aug. 6, 2021**  
Int. Reg. No.: **DM/217237**  
Int. Reg. Date: **Aug. 6, 2021**  
Int. Reg. Pub. Date: **Nov. 19, 2021**

(30) **Foreign Application Priority Data**

Feb. 7, 2021 (CN) ..... 202130093201.1

(51) **LOC (14) Cl.** ..... **13-02**

(52) **U.S. Cl.**  
USPC ..... **D13/108; D32/31**

(58) **Field of Classification Search**  
USPC ..... D13/103, 107, 108, 118, 119, 183; D14/432, 433, 434, 439, 447; D32/25, D32/30, 31; D34/7  
CPC ..... A47L 11/33; A47L 11/4013; H02J 7/0049; H01R 24/00  
See application file for complete search history.

(57) **CLAIM**

The ornamental design for a base station for a cleaning robot, as shown and described.

(56) **References Cited**

**U.S. PATENT DOCUMENTS**

D817,874 S \* 5/2018 Tsai ..... D13/108  
10,383,499 B2 \* 8/2019 Fox ..... B25J 19/005

**DESCRIPTION**

**1.1** is a front view of a first embodiment of a base station for cleaning robot;  
**1.2** is a back view of the first embodiment;  
**1.3** is a left view of the first embodiment;  
**1.4** is a right view of the first embodiment;  
**1.5** is a top view of the first embodiment;  
**1.6** is a bottom view of the first embodiment;  
**1.7** is a perspective view of the first embodiment;  
**2.1** is a front perspective view of a second embodiment of base station for cleaning robot; and  
**2.2** is a back perspective view of the second embodiment.

(Continued)

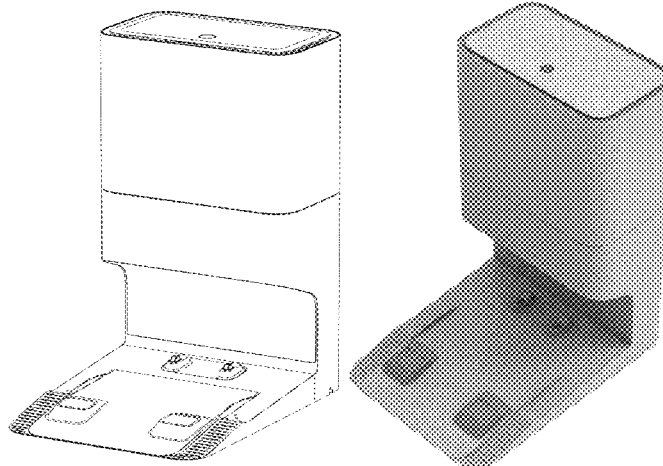

In the reproductions, the broken lines depict portions of the base station for a cleaning robot that form no part of the claimed design.

**1 Claim, 9 Drawing Sheets**

(56)

**References Cited**

U.S. PATENT DOCUMENTS

D924,522 S \* 7/2021 Jang ..... D34/7  
D930,580 S \* 9/2021 Sexton ..... D13/108  
D939,436 S \* 12/2021 Chei ..... D32/31  
D946,519 S \* 3/2022 Gao ..... D13/108  
D948,822 S \* 4/2022 Kim ..... D32/31  
2016/0183752 A1 \* 6/2016 Morin ..... A47L 9/009  
15/340.1  
2020/0069139 A1 \* 3/2020 Johnson ..... A47L 9/149  
2020/0405107 A1 \* 12/2020 Na ..... A47L 5/22

OTHER PUBLICATIONS

“Roomba i7”. Found online Jan. 10, 2022 at slashgear.com. Reference dated Sep. 6, 2018. Retrieved from <https://www.slashgear.com/irobots-self-emptying-roomba-i7-fixes-robot-vacuums-big-headache-06544635/>. (Year: 2018).\*

“Bissell CrossWave Vacuum”. Found online May 18, 2022 at youtube.com. Reference dated May 3, 2019. Retrieved from <https://www.youtube.com/watch?v=Ehsir8IUDBk>. (Year: 2019).\*

Taiwanese Notice of Allowance dated Nov. 4, 2021 in connection with Taiwanese Application No. 110304088.

Japanese Patent Office Application No. 2021-502290 First Office Action dated Aug. 19, 2022.

\* cited by examiner

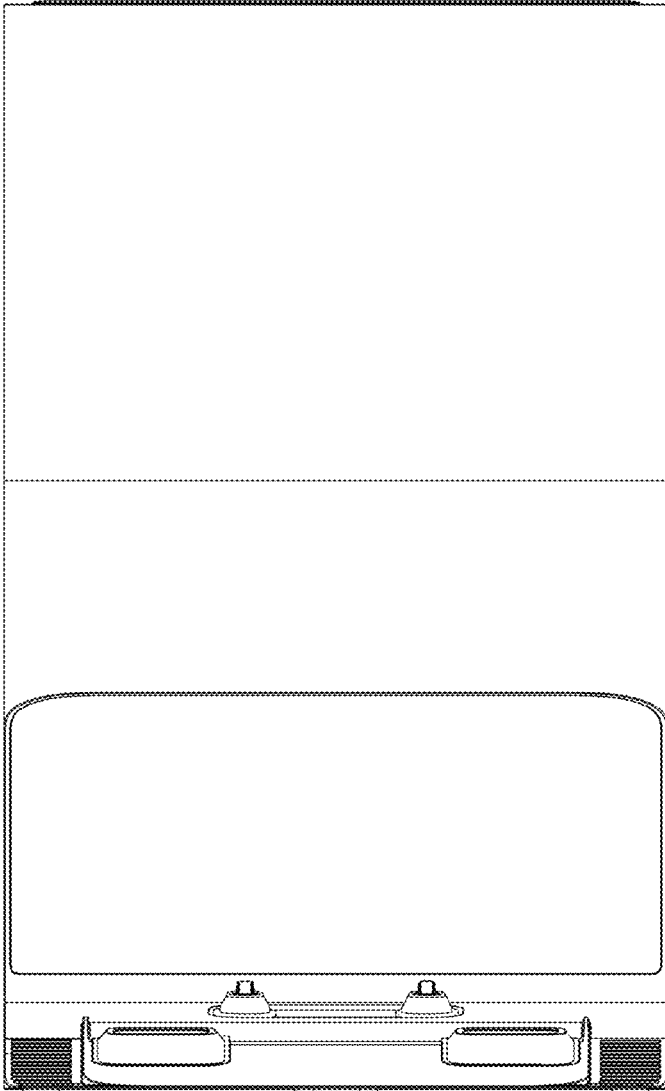

1.1

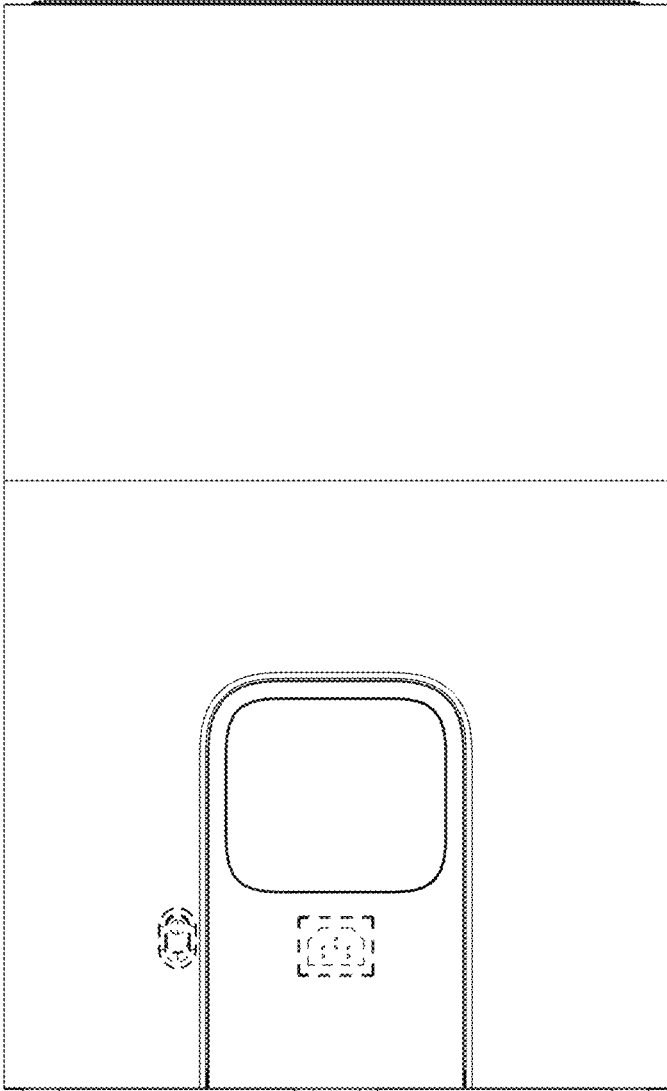

1.2

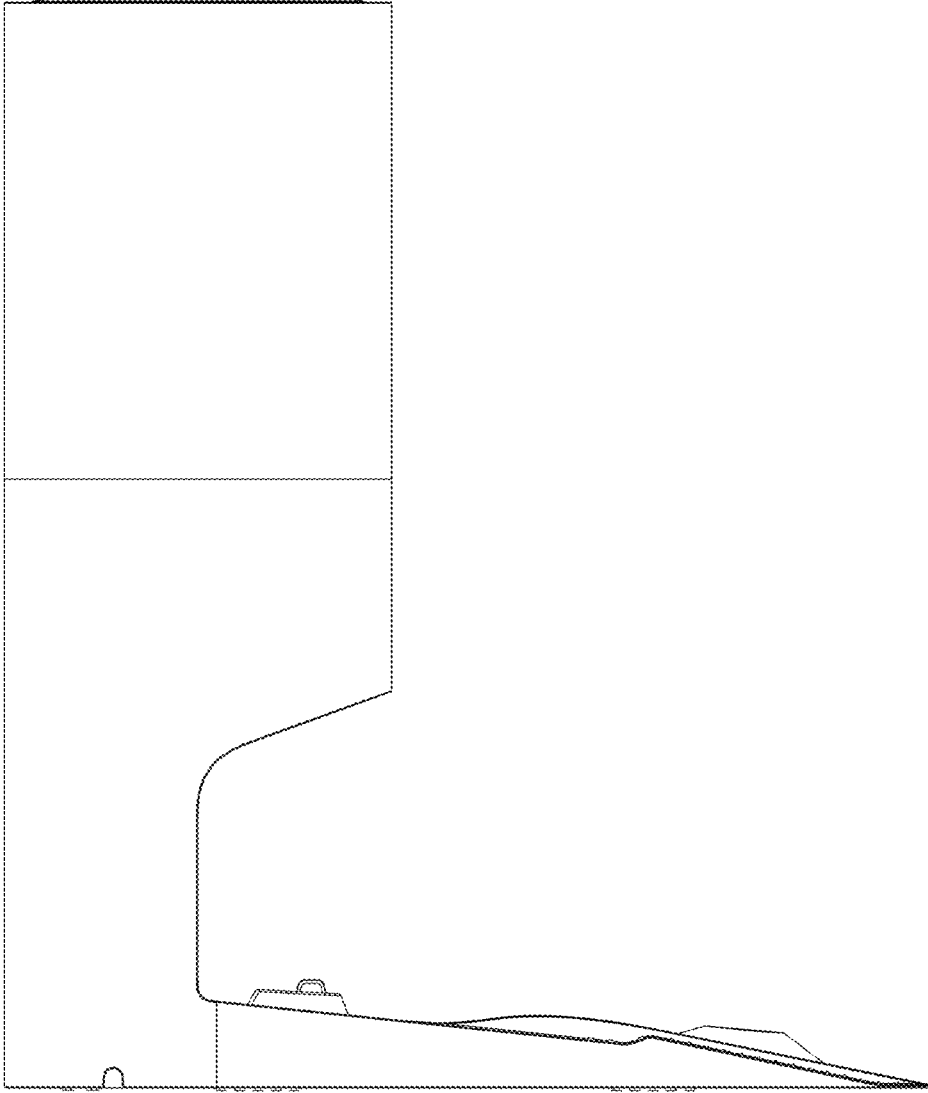

1.3

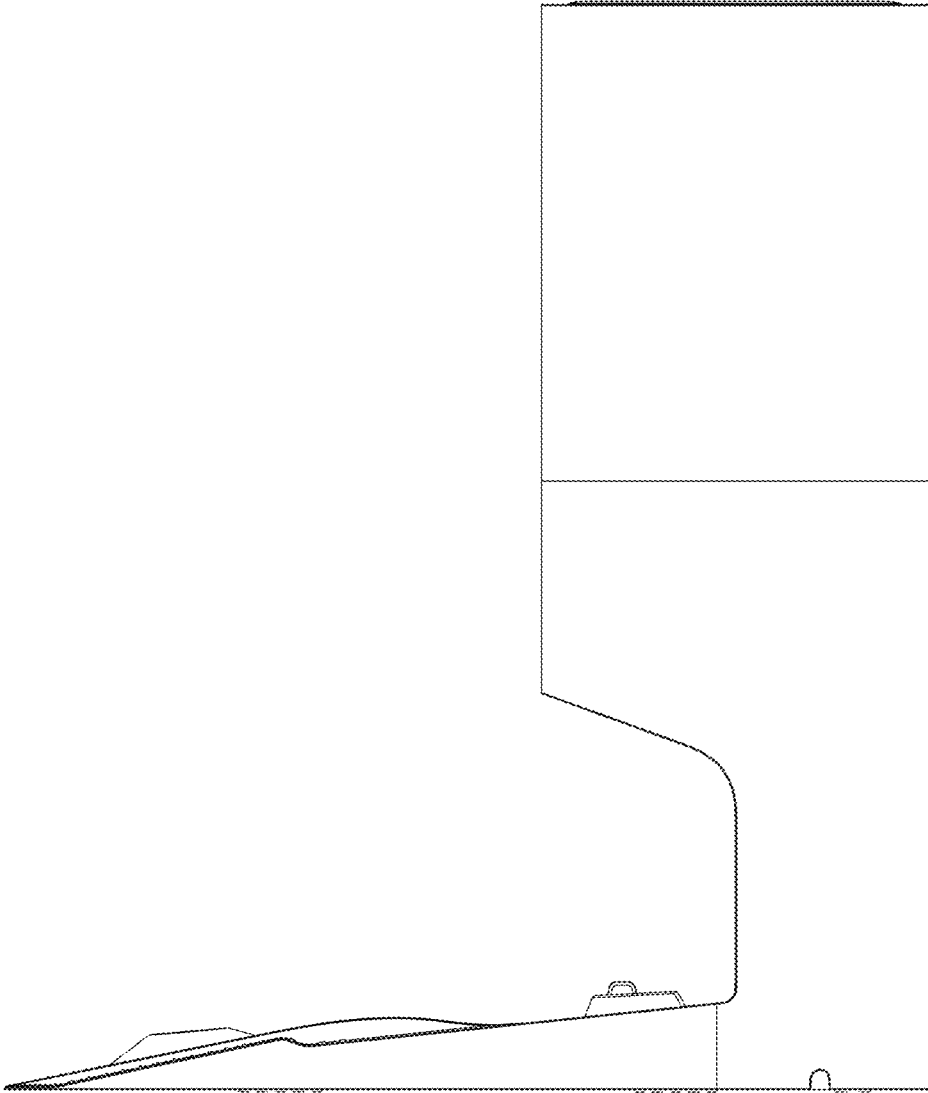

1.4

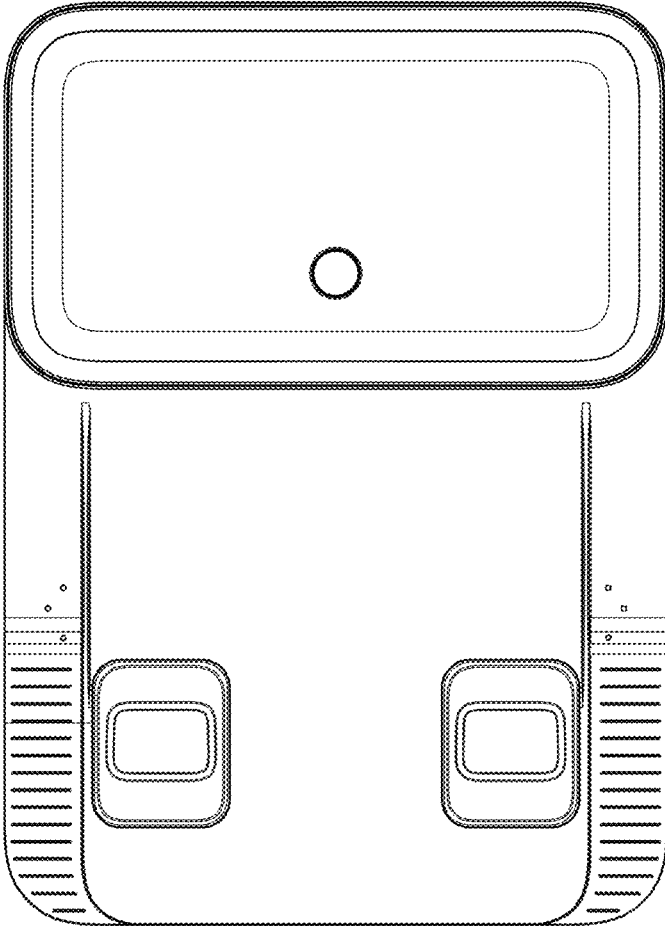

1.5

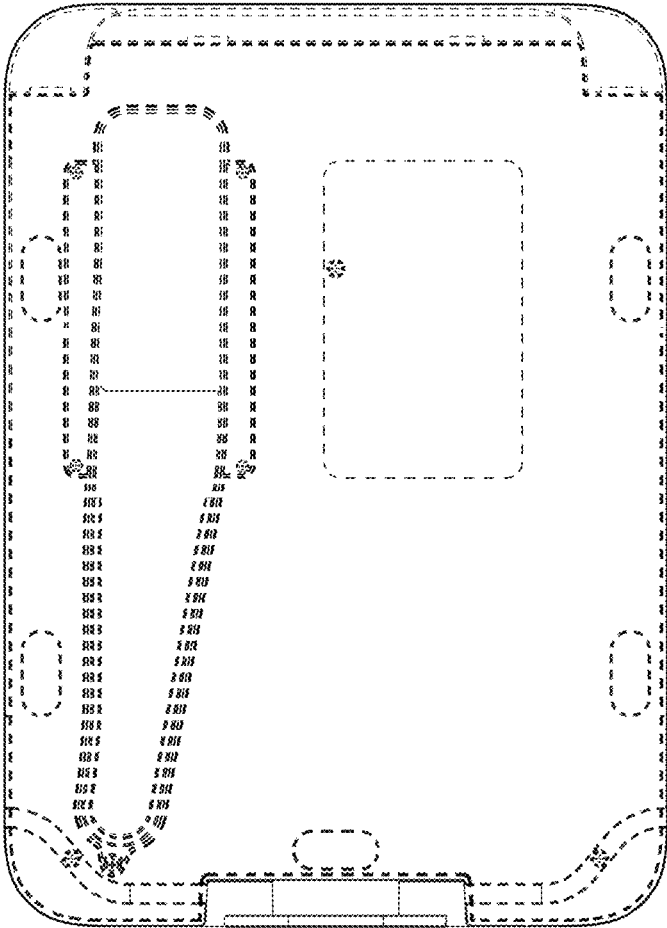

1.6



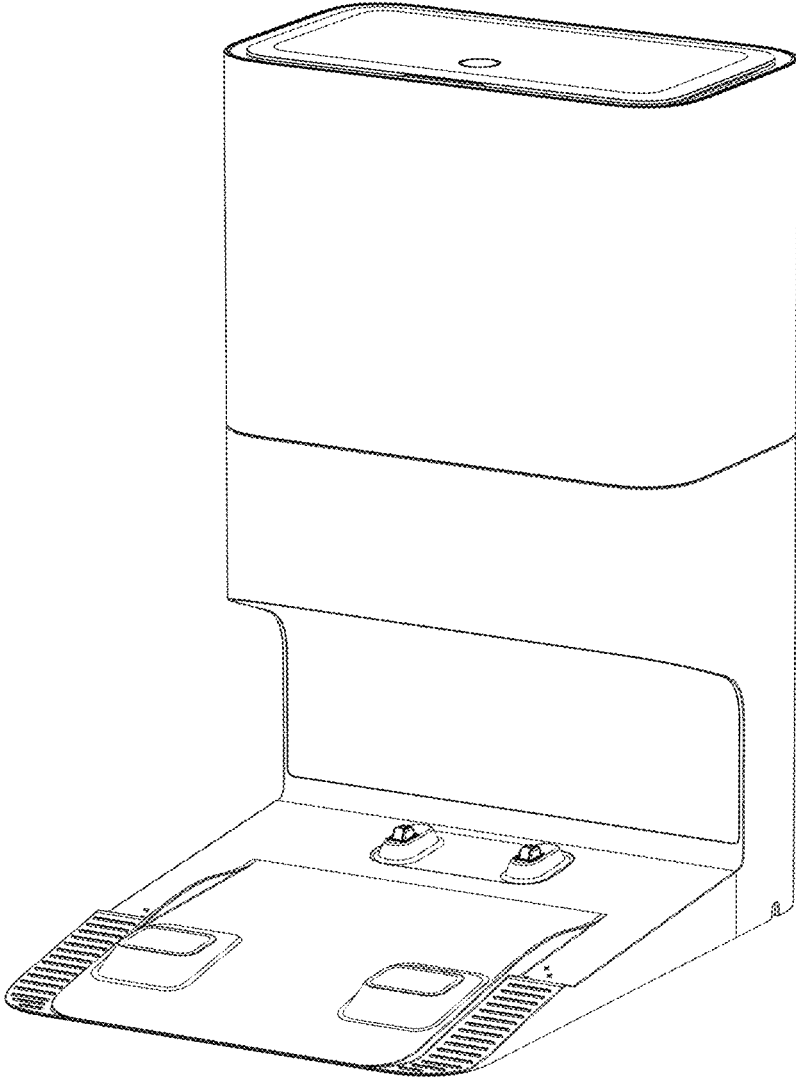

1.7



2.1



2.2