

Aug. 30, 1966

ZENICHI NAKANO

3,270,174

OPERATING MECHANISMS OF AIR-FILLED AIR-BREAK CIRCUIT BREAKERS

Filed Oct. 7, 1964

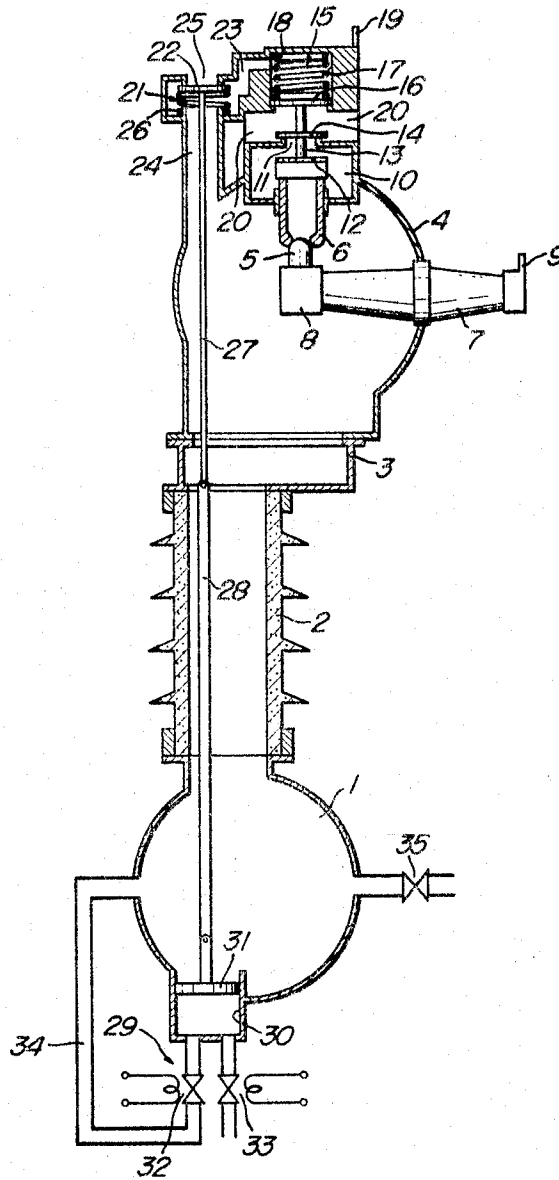

INVENTOR

ZENICHI NAKANO

BY *Paul M. Craig, Jr.*

ATTORNEY

1

3,270,174

## OPERATING MECHANISMS OF AIR-FILLED AIR-BREAK CIRCUIT BREAKERS

Zenichi Nakano, Hitachi-shi, Japan, assignor to Hitachi, Ltd., Tokyo, Japan, a corporation of Japan

Filed Oct. 7, 1964, Ser. No. 402,154

1 Claim. (Cl. 200-148)

This invention relates to improvements in or relating to operating mechanisms of air-filled air-break circuit breakers in which at least a pair of relatively movable contact devices are arranged in a chamber normally filled with high pressure air, and actuated by a driving device disposed behind the movable contact device, the driving device being mechanically operated from a piston device disposed in the portion of the circuit breaker that is at the ground potential.

An object of the present invention is to provide an operating mechanism of the kind specified, in which the operating rod connecting the driving device for movable contact with the piston device is always under tensile stress during operation, whereby the operating mechanism is remarkably simplified.

Another object of the present invention is to provide an operating mechanism of the kind specified, in which the operating rod of insulating material is disposed in a chamber filled with air under high pressure for preventing lowering of its insulating strength against creeping discharge.

A further object of the present invention is to provide an operating mechanism of the kind specified, which is of very small mechanical inertia for enabling relatively high speed operation of the circuit breaker.

There are other objects and particularities of the present invention, which will be made obvious from the following detailed description of the invention with reference to the accompanying drawing, in which the single figure shows a longitudinal sectional elevation of a circuit breaker embodying the invention.

As is well-known, in conventional gas-filled type circuit breakers, the operating force is transmitted by a link mechanism disposed in a chamber filled with an arc-extinguishing gas, which link mechanism is necessarily under compressive stress during its operation in one or other sense, circuit-opening or closing operation. Consequently, the operating mechanism or the operating rod should be of a sufficient rigidity not to be deformed or distorted under the compressive stress, and as a result, the operating mechanism cannot be made small size beyond a certain extent. However, according to the present invention, the operating rod is always under tensile stress either in circuit-opening or circuit-closing operation, and the operating mechanism is remarkably simplified with very small mechanical inertia, enabling operation at highly increased speed.

Referring to the drawing, the circuit breaker shown comprises an air reservoir 1 maintained at the ground potential, and filled with air under high pressure. On the air reservoir 1, a supporting insulator tube 2 is disposed upstanding, serving also as a connection tube communicating with the air reservoir 1. A hollow platform 3 is mounted on the top of insulator tube 2 for supporting a breaker tank 4 mounted thereon in communication with the air reservoir 1. Consequently, the breaker tank 4 is filled with air under pressure same with that in the air reservoir 1. In the tank 4, a pair of relatively movable contacts 5 and 6 are disposed. The stationary contact 5 is mounted on a support 8 secured to the inner end of an insulating bushing 7 passing through the wall of breaker tank 4 with air-tightness, and electrically connected with a terminal member 9 secured to the outer end of the insulating bushing 7. The movable contact

2

6 is of a nozzle shape and vertically slidable with respect to a movable-contact casing 10 formed on the upper portion of breaker tank 4. The movable contact 6 carries at the top end a valve plate 12 for closing a valve opening 11 from underside, the valve opening 11 being for communicating the casing 10 with an exhaust port 20. The movable contact 6 also carries thereon an upstanding valve stem 13 on which is mounted another valve plate 14 for closing the valve opening 11 from upsideside. The upper end of valve stem 13 is connected with an actuating piston 16 in a cylinder 17 constituting a driving device 15. A compression spring 18 is disposed in the cylinder 17, for serving as a bumper in the circuit opening operation. An external terminal member 19 is formed at the top of the driving device casing. Between the driving device 15 and the movable contact casing 10 is formed the exhaust port 20 in communication with the casing 10 through the valve opening 11 which is closed by the valve plate 14 when the circuit breaker is closed as shown.

For controlling supply of compressed air to the driving cylinder 17 from the breaker tank 4, a receiver valve device 21 is provided. The receiver valve comprises a valve plate 22, which, in one position shown in the drawing, establishes communication from the breaker tank 4, through an upstanding passage tube 24, and an air port 23, to the chamber of driving cylinder 17 above the piston 16, while, in the other position, it closes the top opening of passage tube 24, and connects the air port 23 to the atmosphere through an exhaust opening 25. The valve device 21 is provided with a compression spring 26 for biasing the valve plate 22 to close the exhaust opening 25. The valve plate 22 is fixed to the top end of an operating rod 27 of insulating material, which extends vertically through the passage tube 24, breaker tank 4 and the hollow platform 3, and is pivotally connected to an insulating link 28 at the lower end. The link 28 also extends vertically through the hollow insulator 2 and air reservoir 1, and the lower end thereof is mechanically connected to a piston 31 of transmitter device 29. The transmitter piston 31 is operable in a cylinder 30 formed integral with the air reservoir 1 and opening thereinto. The chamber in the transmitter cylinder 30 below the piston 31, that is, the chamber opposite to the air reservoir side, is connected to a circuit-closing electromagnetic valve 32 and a circuit-opening electromagnetic valve 33. The circuit-closing valve 32 controls supply of compressed air from the air reservoir 1 through a pipe 34 to the chamber of cylinder 30 below the piston 31. The air reservoir 1 is fed with compressed air through a feed valve 35.

When the circuit breaker is in the closed position as shown in the figure of drawing, the circuit closing electromagnetic valve 32 is in open position, in which the chamber of transmitter cylinder 30 below the piston 31 is in communication with the air reservoir 1, and the compressed air supplied therefrom makes the opposing forces acting on the transmitter piston 31 balanced, and the spring 26 and the differential air force acting on the valve plate 22 hold the receiver valve device 21 in the position in which the exhaust opening 25 is closed and the air port 23 is communicated to the breaker tank 4. Air under high pressure is thus supplied to the upper chamber of the driving cylinder 17 to drive the piston 16 downwards for pressing the movable contact 6 against the stationary contact 5, and at the same time, for closing the valve opening 11 from upsideside by the valve plate 14. In order that there is assured of a predetermined and most effective contact pressure between contacts 5 and 6 at the above-mentioned position, a suitable and adjustable spring means may be provided in the contact support 8 as is well-known. In the closed

3

position of the circuit breaker, current flows from the terminal 19, through the conducting portions of the casing 10, contacts 6 and 5, and the conductor of the insulating bushing 7, to the terminal 9.

For opening the circuit, the closing electromagnetic valve 32 is closed and the opening electromagnetic valve 33 is opened, whereupon the lowerside chamber of transmitter cylinder 30 is disconnected from the air reservoir 1 and connected to the atmosphere. The differential air pressure acting on the transmitter piston 31 drives the same downwardly. This driving force is so designed that it is considerably larger than the upward force acting on the receiver valve plate 22 by virtue of the spring 25 and the air pressure acting underside the valve plate. The valve plate 22 is thus actuated to close the top opening of the passage tube 24 and connect the air port 23 to the exhaust port 22. Thereupon, the upperside chamber of driving cylinder 17 is connected to the atmosphere, and the upward differential air pressure acting on the valve plate 14 drives the movable contact 6 upwardly to open the circuit. The electric arc drawn between the contacts 5 and 6 is extinguished by a high speed flow of compressed air from the breaker chamber 4 through the nozzle of movable contact 6, the valve opening 11 now opened, and the exhaust port 20.

The upward movement of movable contact 6 is decelerated by the spring 18 and stopped by the valve plate 12 coming to close the valve opening 11 from underside. Thereupon, the valve plate 12 is held thereat by the differential air pressure, and the insulation between contacts 5 and 6 is maintained by the high pressure air in the breaker tank 4.

According to the present invention, the transmitter piston device 29 disposed at the lower portion of the circuit breaker which is at the ground potential, and the receiver valve device 21 are mechanically connected together by the insulating operating rod 27 and the insulating connecting link 28 extending through the air feed tube 24, breaker tank 4, insulator 2 and air reservoir 1. As a result, the creepage insulating strength of operating rod 27 and connecting link 28 is maintained high by the high pressure air in the air reservoir 1 and breaker tank 4. In general, the air used in the reservoir 1 and tank 4 is of very low humidity, so that deterioration of insulation is little. By reason of the fact that the receiver valve device 21 and the transmitter

4

piston device 29 are mechanically connected together, the movement of transmitter piston device is transmitted direct to the receiver valve device, with least time lag, resulting in high speed operation of the circuit breaker.

Further, according to the present invention, the insulating rod and link mechanically connecting the transmitter piston 31 with the receiver valve element 22 is always under tensile stress only during both opening and closing operations of the circuit breaker, and consequently, the insulating rod 27 and link 28 may be of very small cross-section, since in general, the tensile strengths of insulating materials are far larger than their compressive strength. Consequently, the mechanical inertia of the whole operating mechanism can be made very small, enabling high speed operation of the circuit breaker.

What is claimed is:

An operating mechanism of air-filled air-break circuit breaker, comprising relatively movable contact devices disposed in a chamber normally filled with high pressure air and insulated from the ground, and a driving device disposed adjacent to said contact devices for actuating the same to open and close by charging and exhausting of high-pressure air to said driving device, characterized by further comprising a receiver valve arranged adjacent to said driving device and having a valve element which makes charging of air under pressure to said driving device at one position and exhausting of air therefrom at the other position, a high-pressure air reservoir at the ground potential, a transmitter piston device associated with said air reservoir and controlled by an electromagnetic valve, an air feed tube for supplying air under pressure to said driving device from said chamber of high pressure air, a hollow insulator connecting said chamber with said air reservoir, and an operating means of insulating material mechanically connecting said receiver valve element to said transmitter piston device, and extending through said air feed tube, said chamber of high pressure air, said hollow insulator and said air reservoir, said operating means being always under tensile stress during both circuit opening and closing operations.

No references cited.

ROBERT K. SCHAEFER, *Primary Examiner.*