

(21) Application No: 0522630.3  
(22) Date of Filing: 07.11.2005  
(30) Priority Data:  
(31) 0520891 (32) 14.10.2005 (33) GB  
(31) 0522133 (32) 31.10.2005

(51) INT CL:  
F03B 13/26 (2006.01)  
(52) UK CL (Edition X ):  
F1S S28A  
(56) Documents Cited:  
GB 2348249 A EP 1604107 A1  
JP 550072665 A  
(58) Field of Search:  
UK CL (Edition X ) F1S  
INT CL F03B  
Other: Online: WPI, EPODOC

(71) Applicant(s):  
Tidal Generation Limited  
(Incorporated in the United Kingdom)  
7 Dowry Square, BRISTOL, BS8 4SH,  
United Kingdom

(72) Inventor(s):  
George James Gibberd  
Christopher Shane Huxley-Reynard

(74) Agent and/or Address for Service:  
Tidal Generation Limited  
7 Dowry Square, BRISTOL, BS8 4SH,  
United Kingdom

(54) Abstract Title: Flow alignment device for tidal generating apparatus

(57) A submerged horizontal axis axial flow turbine (1) and (2) designed to generate electricity from water currents is mounted to a fixed rigid support structure (3) by means of a horizontal axis hinging device (4) and (5). The distributions of buoyancy (B) and mass (C) are arranged to cause the turbine to assume a substantially vertical orientation at slack water. When the water current begins to flow the turbine leans over to the downstream side of the support structure, pivoting about the horizontal axis hinging device. Once the turbine begins to generate it maintains a substantially horizontal orientation under the rotor thrust load. When the current changes direction the turbine flips over vertically about the horizontal axis hinging device, to face the other direction.

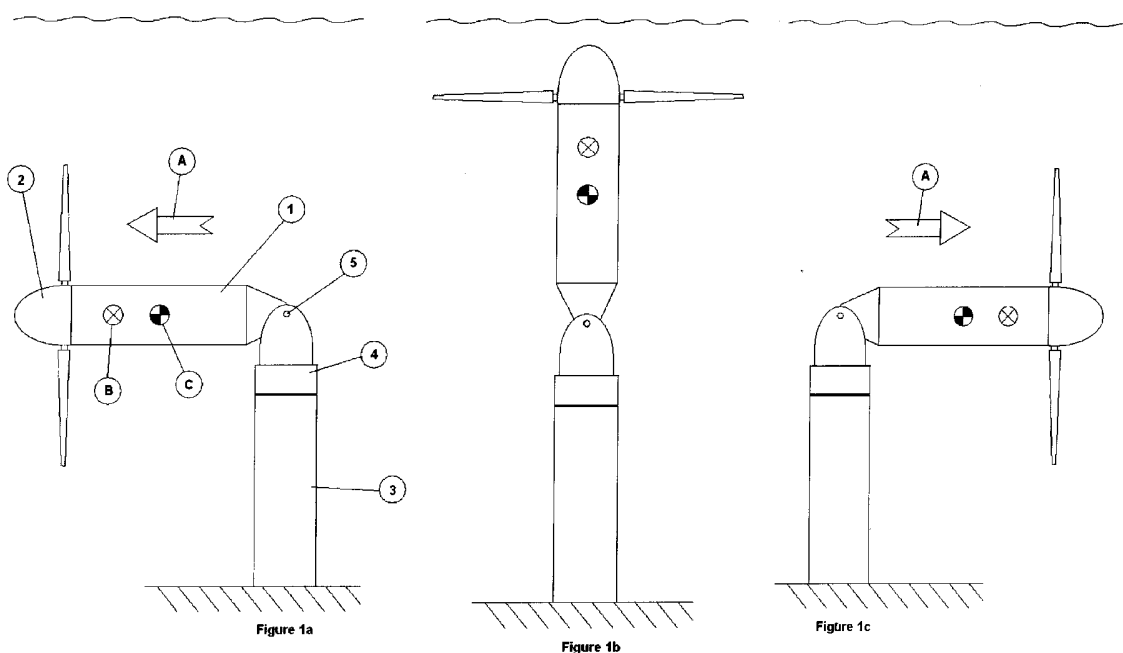

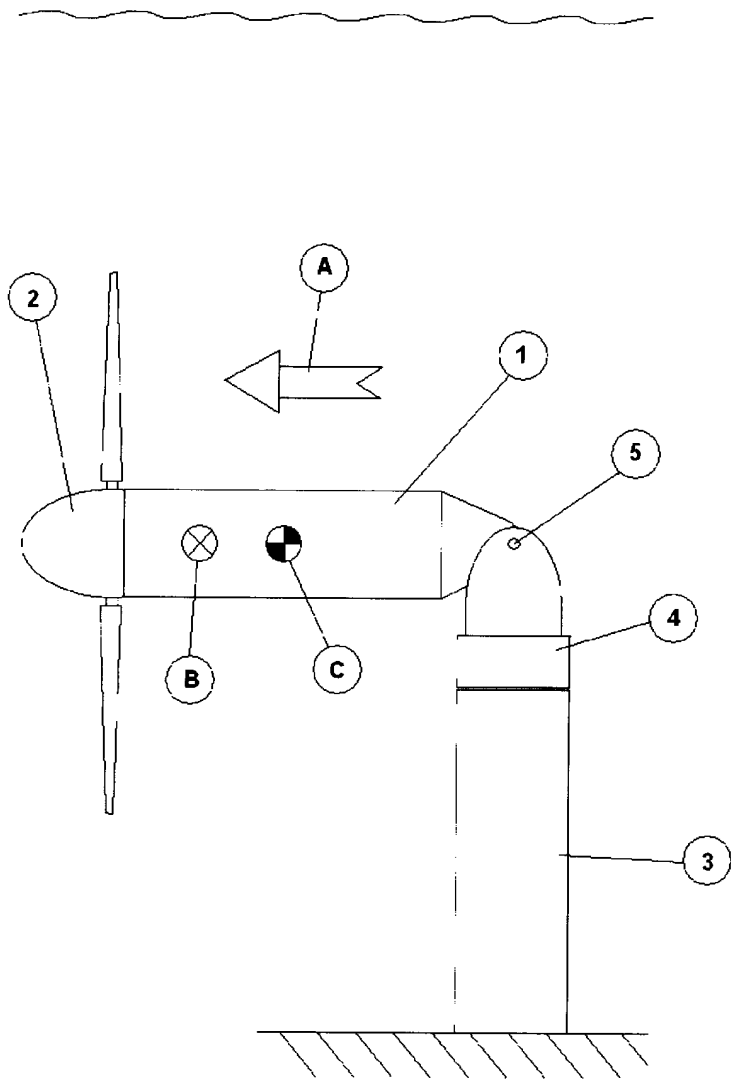

Figure 1a

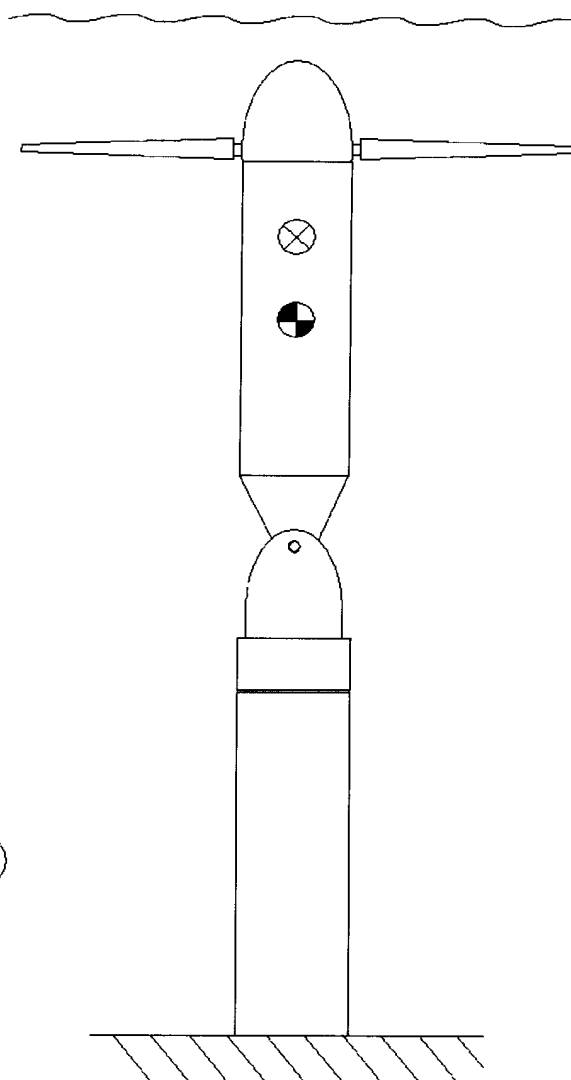

Figure 1b

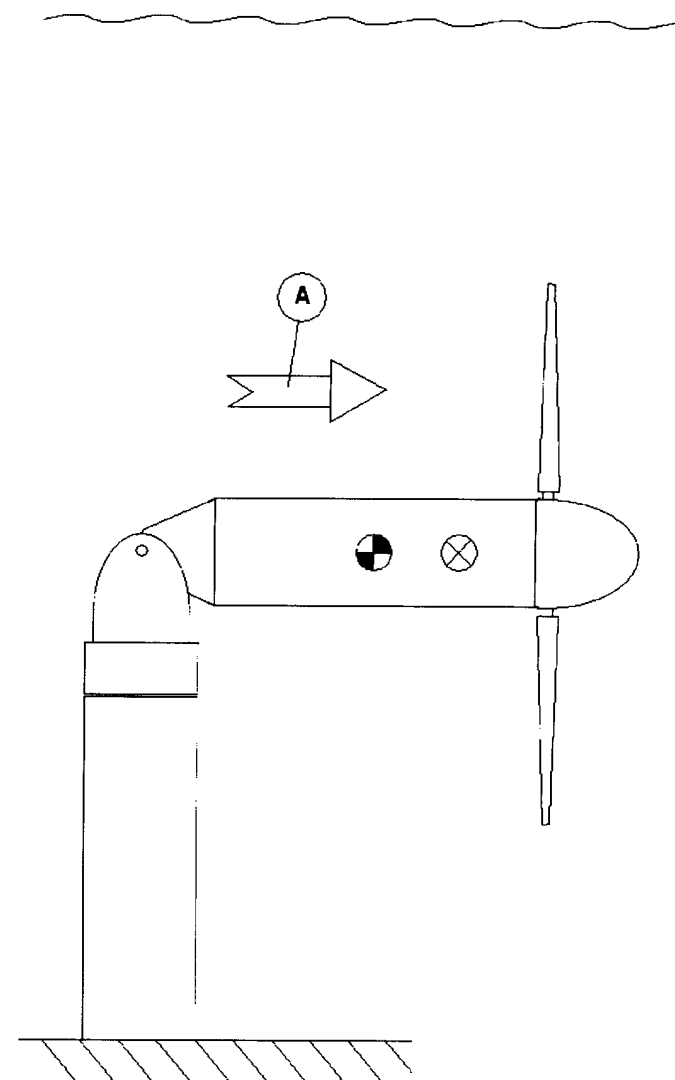

Figure 1c

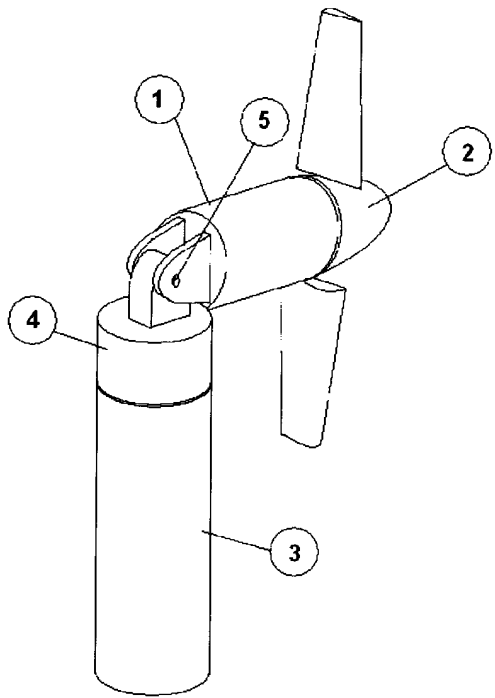

Figure 2

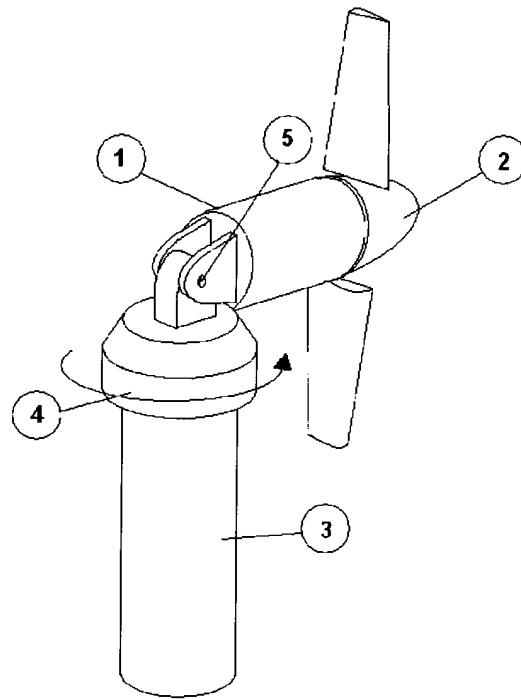

Figure 3

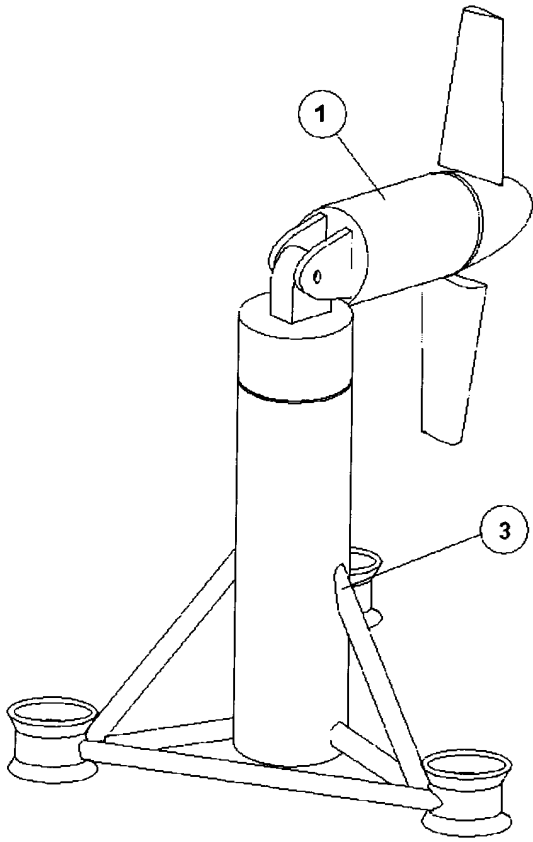

Figure 4

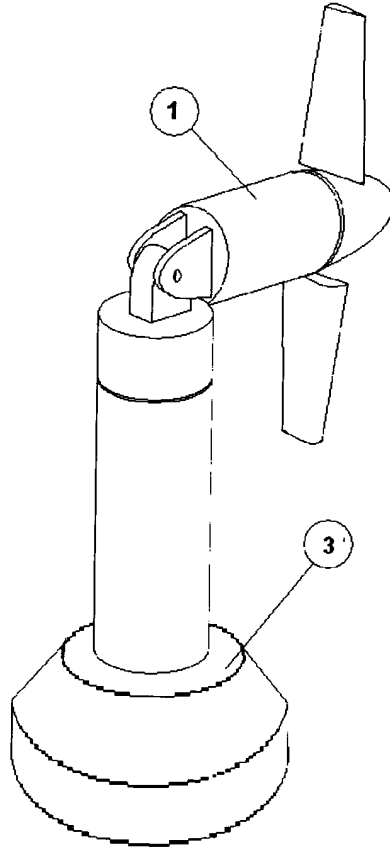

Figure 5

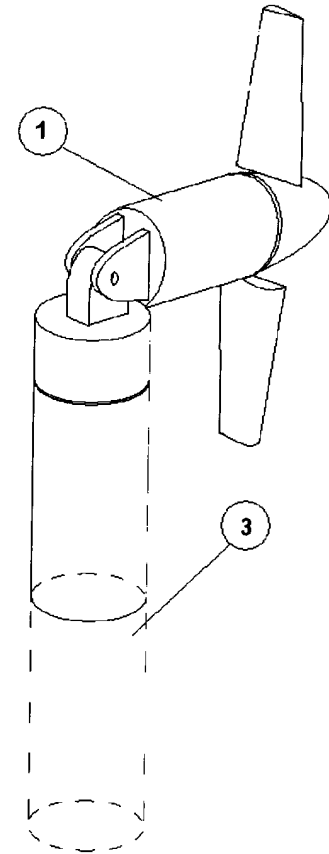

Figure 6

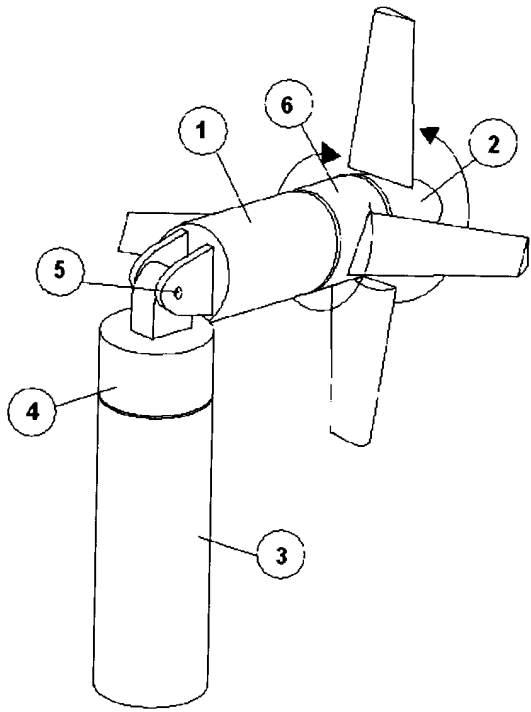

Figure 7

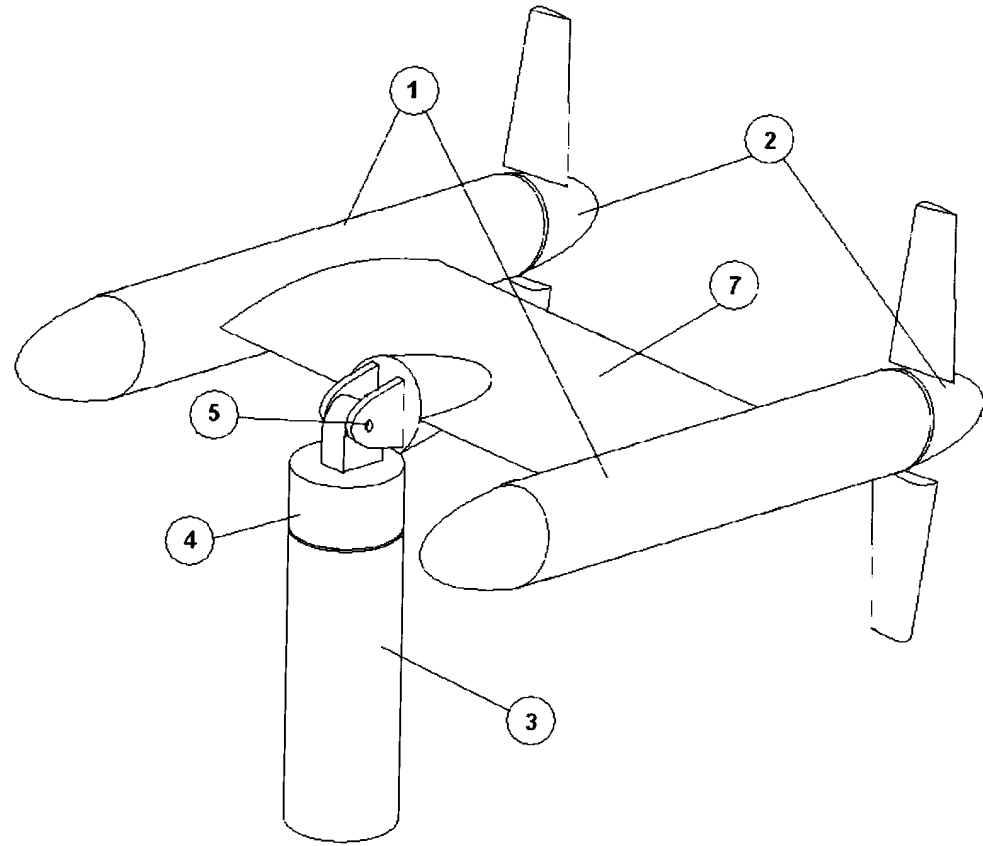

Figure 8



## **A flow alignment device for water current power generating apparatus**

### **Background**

This invention relates to the design of apparatus for extracting energy from water currents and converting it into electricity. Specifically it relates to means by which such apparatus can generate in bi-directional currents such as those seen during a flood / ebb tidal cycle.

Many designs of water current generating device have been proposed. The key technical requirements for all these devices are:

- An efficient prime mover to extract energy from the flow
- A secure means of attaching the prime mover to the seabed or riverbed
- A means to allow it to generate in different water current flow directions
- A means to limit the power output in strong water currents to avoid overloading
- Ability to survive extreme weather conditions (principally wave induced loading)
- High reliability
- Good maintainability achieved through ease and safety of access to the machine

In the majority of cases where water currents can be exploited to generate power, the current flow is bi-directional, as dictated by the directions of the flood and ebb tides. The relative mean directions of flood and ebb current flow are not necessarily exactly 180deg apart as might be expected, but may in fact vary by several tens of degrees due to the local seabed bathymetry, the tidal regime, etc. In addition the instantaneous direction of current flow may vary slightly throughout the course of a flood or an ebb tide.

The way in which bi-directional current flow is catered for in the design of any water current power generating apparatus has a very significant impact on the rest of the machine design. In the marine environment, the issue of overall machine reliability is particularly important to designing a cost effective machine.

Amongst the wide range of prime mover energy extraction devices that have been proposed, the horizontal axis axial flow rotor is widely accepted as the most efficient device. This invention describes a method to allow such a rotor to generate in bi-directional water currents.

## Prior Art

Proposed methods that allow a horizontal axis rotor to generate in a bi-directional current include.

- *Yawing rotor about a vertical axis.* This is the technique used by the wind industry where there is a requirement for the rotor to face the wind blowing from any direction. The scheme requires a yaw bearing capable of transmitting the turbine thrust, torque, pitch and yaw forces/moments to the support structure, as well as a means of driving this yaw bearing around to align the rotor with the flow. In the case of a water current turbine a passively driven yawing system is conceivable using a low friction yaw bearing, but an active yaw drive is probably required to overcome bearing friction. This active yaw drive is a source of added complexity and potential unreliability. To prevent the main electrical cables between the rotor and the support structure from excessive twisting, either yaw position stops or an electrical slipring unit are required. The position stops attract shock loading and the slipring unit is another source of complexity and potential unreliability.
- *Fixed rotor with full span pitch control* When the current direction changes each rotor blade is rotated 180deg about its respective lengthwise axis to face the opposite direction. In hydrodynamic terms this has the same effect as yawing the rotor through 180deg. Although this works best when the flow is purely bi-directional (eg flood and ebb tide 180deg apart), the system will still work reasonably efficiently as long as the two current directions are close to 180deg apart. The principle drawback of such a system is the mechanical and/or electrical complexity of the pitch system. Electrical or hydraulic pitch actuators housed inside the rotor hub are required to provide the 270deg pitch control necessary for the system to work. Since the rotor hub is spinning round, sliprings are required to provide electrical power or hydraulic fluid to these rotor hub actuators. In addition feedback of the blade position to a machine controller must also pass back through these sliprings. The system is therefore complex and has the potential to be unreliable.
- *Fixed rotor employing fixed pitch reverse flow blades* The rotor blade aerofoil section is designed to allow the blades to operate with flow coming from opposite directions without adjusting their pitch or turning the rotor in any way. This can be achieved using a blade aerofoil section profile which is symmetric about both the local blade chord and vertical axes (an example would be a flattened ellipse profile). There will be significant efficiency losses associated with this design of blade section. The system overcomes the potential reliability problems of active pitch control, active yaw and the use of sliprings, but this may not make up for the loss in efficiency.



- *Positively buoyant rotor tethered to seabed:* A fully submerged positively buoyant rotor (or group of rigidly connected rotors) is tethered to the seabed. When the rotors are generating they are supported mid water column by the balancing forces of turbine thrust, buoyancy, and the resultant tension in the mooring tethers. The level of the rotors in the water column changes with the current speed and amount of thrust generated. When the current reverses direction the rotors flip vertically over to point the other direction. The main disadvantage of this system is that the rotor is not supported at a fixed point in the water column. The rotors are free to move up and down with changing water current speed. If there is any significant turbulence or wave induced fluctuations in the current flow, these will cause the apparatus to move around constantly, both vertically and laterally. This unrestricted movement may pose dynamic stability problems and will introduce tugging loads on the seabed moorings. The amount of net buoyancy required to balance the thrust is considerable for a commercial size machine of around 1 mega Watt, and is likely to require a sizeable dedicated pressure rated buoyancy chamber. The tethered mooring arrangement also makes it more difficult to protect electrical power cables running from the turbines to the seabed.
- *Rotor tethered to suspended mooring line:* A fully submerged rotor (or group of rotors) is tethered to a mooring line which spans a channel mid water column. The two ends of this mooring line are anchored into the shore or river bed. The rotor can flip over or under the mooring line on its tether, depending on whether it is arranged to be positively or negatively buoyant. The main disadvantage with this arrangement is that it is very location specific. It requires a steep sided channel to provide suitable anchor points to suspend the mooring line mid water column. The dynamic stability problems are reduced compared to the previous scheme, but not eliminated. If the mooring cable is tight to limit the vertical movement of the rotors, then it will impose very significant loads on its seabed anchors when the rotors are generating.

### Statement of the invention

The present invention seeks to provide a method to enable a water current turbine to generate bi-directionally whilst avoiding so far as possible the disadvantages of prior art.

The invention provides a means of attaching the drive train of a water current generating apparatus to a fixed submerged support structure at the mid water column level, whilst allowing the drive train to flip over vertically through 180deg about a horizontal axis to accommodate a reversal in current flow direction. The invention is a development of a concept already presented in patent application number 0520891.3 "Foundation Structure for Water Current Energy Systems"

The apparatus comprises:

- A fixed submerged rigid support structure which supports the drive train at a constant level mid-water column
- A positively or negatively buoyant water current generating drive train incorporating a horizontal axis rotor and an electrical generator
- A horizontal axis hinging device connecting the drive train with the top of the support structure

When no current is flowing, the drive train naturally sits upright with the plane of the rotor facing vertically upwards by virtue of the drive train's degree of rotational freedom about the hinging device and its distribution of buoyancy relative to its distribution of mass. The drive train may have net positive or negative buoyancy, so long as there is adequate buoyancy concentrated towards the top end to make it sit upright. The residual weight or positive buoyancy force of the drive train is reacted by the hinging device

When the water current begins to flow the drive train will naturally lean over to the downstream side of the support structure, pivoting about the hinging device. The rotor will begin to generate and the thrust force on the rotor, combined with the vertical and lateral restraint provided by the hinge, will maintain the drive train in a stable configuration at a steady position in the water column, even if waves and flow turbulence are present. When the current reverses direction the drive train flips over vertically about the horizontal axis hinge to point in the opposite direction

In a preferred embodiment the hinging device incorporates suitable fittings to allow it to be attached and detached to/from the support structure underwater by a diver or Remotely Operated Vehicle (ROV), or by means of an automatic latching mechanism that requires no external intervention. This has the advantage of allowing the hinging device to be brought to the surface with the drive train for inspection and maintenance.

In a preferred embodiment an additional vertical axis hinging device is incorporated between the horizontal axis hinging device and the support structure. This has the advantage of allowing the drive train orientate itself in yaw with respect to current flow directions that are not exactly 180deg apart, as well as relieving the support structure of rotor induced yawing moments

In a preferred embodiment the vertical axis hinging device proposed above incorporates yaw position stops at a suitable angle either side of the nominal yaw positions on for the two current directions. This has the advantage of preventing the drive train from rotating a whole revolution about the vertical axis and twisting the power cables.

In a preferred embodiment the horizontal (and optionally vertical) axis hinging device comprises one or more plain water lubricated bearings. This has the advantage of minimising the cost of the hinge manufacture and maintenance.

In an alternative arrangement the horizontal (and optionally vertical) axis hinging device comprises one or more rolling element bearings. This has the advantage of reducing the friction and wear of the hinges.

In a preferred embodiment and for the purpose of deploying and retrieving the drive train onto/from the support structure from/to the surface, the proposed alignment device is employed in combination with a winching device. This winching device concept is presented in its general form in a separate patent application number 0522133.8 "A deployment and retrieval apparatus for submerged power generating devices". In this instance a winching device is mounted beneath the drive train on the hinging device. The drive train is positively buoyant and floats on the surface prior to deployment onto the support structure. A tether is paid out from the winching device and attached to the top of the support structure underwater. The winching device pulls the drive train down through the water column onto the support structure, powered by a motor drive unit which may be detachable. The winching device is positioned beneath the hinging device so as to pull directly beneath the centre of buoyancy of the drive train when it is in a vertical orientation, such that the drive train and hinging device maintain a suitable and stable orientation for mating with the support structure. A latching mechanism is incorporated to secure the hinging device to the support structure once they have been mated together. At this point the motor drive unit can be detached if required. The proposed combination of winching device with the alignment device has the advantage of providing an easy means to access the drive train for the purposes of inspection and maintenance. A further advantage of this particular arrangement is that the horizontal axis degree of freedom of the drive train about the hinge makes it easier to mate the hinging device with the support structure.

In a preferred embodiment part of the horizontal axis hinge is hollow to allow electrical, hydraulic or fibre optic cables to be fed through it from the drive train to the support structure. This has the advantage of minimising cable bending each time the device flips over, and offers good protection to the cables from the water current.

In a preferred embodiment the rotor employed is of fixed pitch design, intended to operate in current flow coming from one apparent direction. This has the advantage of improving the efficiency of the machine compared to a fixed pitch reverse flow rotor as identified in prior art, whilst avoiding the use of more complex active pitch devices.

In an alternative arrangement the rotor employed is of variable pitch design, incorporating rotor blades that are capable of pitching about their lengthwise axes. This has the advantage of improving the efficiency and controllability of the machine still further compared to a fixed pitch rotor.

### **Advantages of the invention**

The principle advantage of the invention is the way in which it combines.

- a fixed, stable drive train support platform
- a reliable, passive system to allow bi-directional generation
- an efficient rotor which does not need to be designed for reverse flow

A further advantage is that the horizontal (and optionally vertical axis) degree/s of freedom will relieve the support structure of rotor induced pitch (and yaw) moments respectively

A further advantage is that the hinge (and optionally yaw bearing) can be easily accessed for maintenance when drive train is brought to surface.

### **Detailed description with reference to drawings**

Different versions of the invention will now be described, by way of example and not in any limitative sense, with reference to the accompanying drawings in which;

Figures 1a, b, c are schematic views of the alignment device in operation

Figure 2 is a view of the alignment device in its simplest form

Figure 3 is a view of the alignment device incorporating an additional yawing degree of freedom about a vertical axis

Figure 4 is a view of the alignment device mounted on a tubular framework type support structure.

Figure 5 is a view of the alignment device mounted on a gravity caisson type support structure.

Figure 6 is a view of the alignment device mounted on a submerged driven pile support structure

Figure 7 is a view of the alignment device in combination with a contra-rotating rotor drive train

Figure 8 is a view of the alignment device in combination with multiple adjacent rotor drive trains attached rigidly together.

Figure 9 is a detailed cross sectional view of the alignment device incorporating apparatus for the deployment/retrieval of the drive train as well as several other preferred embodiments

Referring to Figure 1a, the drive train is made up of the main body (1) and the rotor (2). (The generator is housed inside the main body, and there may also be a gearbox to step up the rotational speed of the rotor and a frequency converter to transmit power to the shore electrical grid) The drive train is aligned with the flood current (A) and is lying downstream of the support structure (3) The drive train lies almost horizontally by virtue of the significant thrust force on the rotor. Referring to Figure 1b which corresponds to slack water, the drive train has assumed a substantially vertical orientation due to the amount and distribution of buoyancy centred at (B) relative to the amount and distribution of mass centred at (C). Referring to Figure 1c, the current flow (A) is now coming from the opposite direction and the drive train has flipped over about the horizontal axis hinging device to assume a substantially horizontal orientation facing the other way.

Referring to Figure 2, the drive train comprising the main body (1) and the rotor (2) is attached to the horizontal axis hinging device, made up of a horizontal axis hinge element (5) and a base unit (4) The base unit is fitted to the top of the support structure (3). The drive train is free to pivot about the horizontal hinge.

Referring to Figure 3, the base unit (4) incorporates a yawing degree of rotational freedom about a vertical axis. The support structure is thus relieved of rotor induced yawing moments

Referring to Figure 4, the alignment device is shown mounted on a tubular framework support structure, which could be a tripod. The legs of the tripod would be suitably anchored to the seabed with piles or by other suitable means known by those persons skilled in the art Referring to Figure 5, a ballasted gravity caisson is employed as a support structure foundation. Referring to Figure 6, a single submerged driven tubular pile foundation is used as a support structure. So long as the support structure is fixed and supports the drive train at a constant level in the water column, many types of support structure and foundation can be used The examples shown in Figures 5, 6 and 7 are not intended to be limitative in any sense

Referring to Figure 7, contra-rotating rotors (2) and (6) are mounted on the main body of the drive train (1) to reduce or eliminate the generating torque transmitted to the support structure

Referring to Figure 8, a pair of rotors are mounted adjacent to one another on a structural member (7) which itself pivots about the horizontal hinge (5). It is probably desirable to incorporate a degree of yawing freedom about a vertical axis in this instance similar to the version depicted in Figure 3, though this is not shown in the figure. This is due to the more significant yawing moments that might be generated by a multiple rotor arrangement which would otherwise be transmitted to the support structure,

Referring to Figure 9, the drive train is being deployed onto the support structure after a maintenance outage using a winching device fitted to the base unit of the horizontal axis hinging device. The design of the winching device is the subject of another patent entitled "A deployment and retrieval apparatus for submerged power generating devices". In this instance the drive train consisting of the main body (1) and rotor (2) is positively buoyant, and lies in a vertical orientation at slack water, held in this orientation by the winching device tether (20). The base unit of the horizontal axis hinging device incorporates a vertical axis yaw degree of freedom. This base unit is therefore made up of an upper part (4) and a lower part (8), which yaw relative to each other on plain water lubricated bearings (9) and (10). These bearings are capable of reacting the rotor thrust load and also the positive buoyancy force of the rotor into the support structure. The power (and any other) cables from the generator (11) are passed through one of the hinges (5) so as to reduce cable bending each time the drive train flips over. The cables are coiled inside the base unit in such a way as to allow limited yawing of the drive train without causing damage to these cables. The winching device (12) gathers in the tether (20) whose free end (18) is attached to the top of the support structure (3). The winching device is powered by a detachable motor drive unit (13) with an umbilical running to a surface vessel. The action of powering the winching device pulls the buoyant drive train down through the water column towards the support structure. On first making contact a key on the drive train base unit (14) engages into a guide in the top of the support structure (15). This key orientates the bottom part of the base unit (8) with the top of the support structure about a vertical axis, such that the electrical underwater mate connector (16) and (17) will be suitably aligned when the drive train and support structure finally mate. At this point the bottom part of the base unit (8) latches with the support structure (not shown) and the motor drive unit can be disconnected. The machine is now ready to generate and the electrical power is transmitted back to shore by the seabed cable (19).

## Claims

1. A device for generating energy from water currents comprising  
  
a horizontal axis axial flow drive train incorporating an electrical generator which, when fully submerged and in the absence of any water current flow, takes up a substantially vertical orientation with the axis of rotation of its rotor pointing to the surface by virtue of the appropriate positioning of the turbine's centre of buoyancy relative to the turbine's centre of mass  
  
and a horizontal axis hinge connecting said turbine directly to a fixed rigid support structure in such a way that, under the action of a water current coming from either of two opposing directions, the turbine freely rotates about said hinge to align itself with the oncoming current flow in a substantially horizontal orientation.
2. A device according to claim 1, wherein a vertical axis hinge is incorporated between the horizontal axis hinge and the support structure to provide the turbine with an additional degree of freedom in yaw.
3. A device according to any of the other claims wherein the hinging device can be attached and detached from the support structure under water in order to allow it to be raised to the surface for maintenance with the drive train.
4. A device according to any of the other claims where a winching device mounted on the drive train or on the bottom of the hinging device is used to deploy the drive train onto the support structure.
5. A device according to any of the other claims wherein several contra-rotating rotors are mounted along a common axis are employed
6. A device according to any of the other claims wherein a plurality of adjacent turbines are rigidly connected together, sharing a common horizontal axis hinge connection to the support structure

## Amendments to the claims have been filed as follows

- 10 -

Tidal Generation Limited. GB 0522630.3

### CLAIMS

1. A device for generating energy from water currents comprising
  - 5 (a) a horizontal axis axial flow drive train incorporating an electrical generator which, when fully submerged and in the absence of any water current flow, takes up a substantially vertical orientation with the axis of rotation of its rotor pointing to the surface by virtue of the appropriate positioning of the turbine's centre of buoyancy relative to the turbine's centre of mass
  - 10 (b) and a horizontal axis hinge connecting said turbine directly to a fixed rigid support structure in such a way that, under the action of a water current coming from either of two opposing directions, the turbine freely rotates about said hinge to align itself with the oncoming current flow in a substantially horizontal orientation.
2. A device according to claim 1, wherein a vertical axis hinge is incorporated  
15 between the horizontal axis hinge and the support structure to provide the turbine with an additional degree of freedom in yaw.
3. A device according to any of the other claims wherein the hinging device can be  
20 attached and detached from the support structure under water in order to allow it to be raised to the surface for maintenance with the drive train.
4. A device according to any of the other claims where a winching device mounted  
25 on the drive train or on the bottom of the hinging device is used to deploy the drive train onto the support structure.
5. A device according to any of the other claims wherein several contra-rotating  
rotors are mounted along a common axis are employed
6. A device according to any of the other claims wherein a plurality of adjacent  
30 turbines are rigidly connected together, sharing a common horizontal axis hinge connection to the support structure.
7. A device for generating energy from water currents substantially as hereinbefore described with reference to accompanying drawings.





For Innovation

— 11 —

Application No: GB0522630.3

Examiner: Peter Middleton

Claims searched: 1-6

Date of search: 2 June 2006

### Patents Act 1977: Search Report under Section 17

#### Documents considered to be relevant:

Category	Relevant to claims	Identity of document and passage or figure of particular relevance
X	1-6	JP55072665 A (SAITO KUNIO) see figures and EPODOC abstract: turbine which rotates about horizontal axis to align with water flow
A,E	1-6	EP1604107 A1 (SOIL MACHINE DYNAMICS) turbine is able to rotate about horizontal axis to align with current flow
A	1	GB2348249 A (ARMSTRONG) see figures and abstract: turbine which can rotate about a horizontal axis

#### Categories:

X	Document indicating lack of novelty or inventive step	A	Document indicating technological background and/or state of the art.
Y	Document indicating lack of inventive step if combined with one or more other documents of same category.	P	Document published on or after the declared priority date but before the filing date of this invention.
&	Member of the same patent family	E	Patent document published on or after, but with priority date earlier than, the filing date of this application.

#### Field of Search:

Search of GB, EP, WO & US patent documents classified in the following areas of the UKC<sup>X</sup> :

F1S

Worldwide search of patent documents classified in the following areas of the IPC

F03B

The following online and other databases have been used in the preparation of this search report

Online: WPI, EPODOC