

(19) World Intellectual Property Organization
International Bureau



(43) International Publication Date
27 March 2003 (27.03.2003)

PCT

(10) International Publication Number
WO 03/024590 A1

(51) International Patent Classification⁷: **B01J 23/00**,
23/40, 23/42, 23/58, 23/72, 23/56, 23/44, 23/02, 23/04,
23/70, 23/50, 23/08, 21/04, C23C 4/10, 4/08, B05D 1/04,
5/12

Dublin, OH 43016 (US). **NOMURA, Tadashi** [JP/JP];
687 Imaizumi-cho, Court Izumi C-101, Utsunomiya-shi,
Tochigi 321-0962 (JP). **KIMURA, Eisuke** [JP/US]; 6036
Innovation Drive, Dublin, OH 43016 (US).

(21) International Application Number: PCT/US02/29439

(74) Agent: **BARANOWSKI, Edwin, M.**; Porter Wright Mor-
ris & Arthur LLP, 41 South High Street, Columbus, OH
43215 (US).

(22) International Filing Date:
17 September 2002 (17.09.2002)

(25) Filing Language: English

(81) Designated States (*national*): CA, DE, GB, JP.

(26) Publication Language: English

(84) Designated States (*regional*): European patent (AT, BE,
BG, CH, CY, CZ, DE, DK, EE, ES, FI, FR, GB, GR, IE, IT,
LU, MC, NL, PT, SE, SK, TR).

(30) Priority Data:
09/957,209 20 September 2001 (20.09.2001) US

Declarations under Rule 4.17:

(71) Applicant: **HONDA GIKEN KABUSHIKI KAISHA**
[JP/JP]; N^o. 1-1, Minami-Aoyama 2-chome, Minato-ku,
Tokyo 107-8556 (JP).

- as to the identity of the inventor (Rule 4.17(i)) for all des-ignations
- as to applicant's entitlement to apply for and be granted a patent (Rule 4.17(ii)) for all designations
- as to the applicant's entitlement to claim the priority of the earlier application (Rule 4.17(iii)) for all designations

(71) Applicants and
(72) Inventors: **HE, Ting** [CH/US]; 5794 Norm Street,

[Continued on next page]

(54) Title: SUBSTRATE HAVING CATALYST COMPOSITIONS ON SURFACES OF OPPOSITE SIDES AND METHOD FOR PRODUCING THE SAME

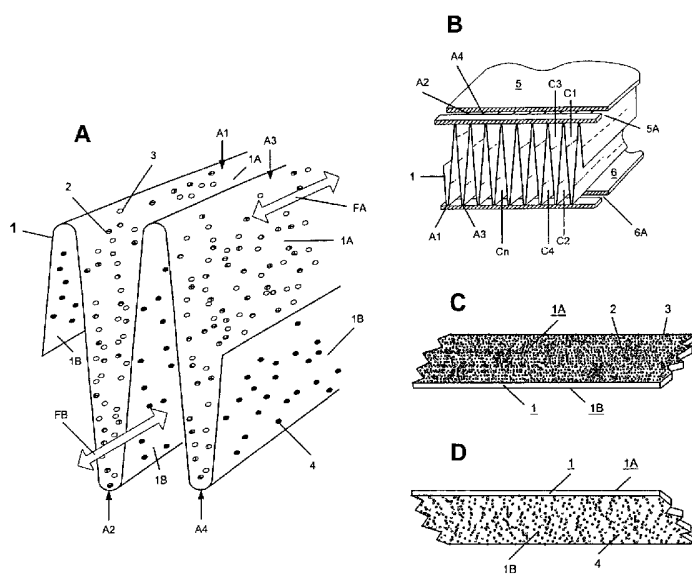

(57) Abstract: A bi-laterally surfaced substrate in which the first surface consists of one or more than one of cerium oxide, aluminum oxide, tin oxide manganese oxide, copper oxide, cobalt oxide, nickel oxide, praseodymium oxide, terbium oxide, ruthenium, rhodium, palladium, silver, iridium, platinum and gold and the second surface consists of one or more than one of ruthenium, rhodium, palladium, silver, iridium, platinum and gold and micro channel micro component reactors including such substrates in a predetermined formed shape and methods for making the same utilizing a thermal spray on one side an physical deposition process on the other side.

WO 03/024590 A1



Published:

— *with international search report*

For two-letter codes and other abbreviations, refer to the "Guidance Notes on Codes and Abbreviations" appearing at the beginning of each regular issue of the PCT Gazette.

TITLE OF INVENTION

SUBSTRATE HAVING CATALYST COMPOSITIONS ON SURFACES OF OPPOSITE SIDES
AND METHOD FOR PRODUCING THE SAME

CROSS-REFERENCE TO RELATED APPLICATIONS

This application is related to co-pending United States application for Letters Patent No. 09/912,223 filed on July 24, 2001, "Substrates With Small Particle Size Metal Oxide and Noble Metal Catalyst Coatings and Thermal Spraying Methods for Producing the Same" and application for Letters Patent No. 09/742,697 filed on December 20, 2000, "Method for Enhancing the Surface of a Substrate and Catalyst Products Produced Thereby," the disclosures of which are hereby incorporated by reference as if set out in full herein.

TECHNICAL FIELD TO WHICH THE INVENTION RELATES

The invention relates to a substrate, such as a metallic thin film or plate, having catalyst compositions on the surfaces of each opposite side of the substrate and methods for applying the catalyst compositions to the opposite sides of the substrate. The invention further relates to catalyst surfaced substrates having predetermined shapes formed for use in micro component reactors.

BACKGROUND ART

Disclosures of processes for the deposition of ceria particles on a substrate include United States Patent No. 5,063,193 to Bedford *et al.* which describes a wash coat of high surface area ceria particles and the preparation thereof in which cerium carbonate is converted to ceria via

SUMMARY OF THE INVENTION

The present invention provides a bi-laterally surfaced (or coated) substrate. A first predetermined surface, such as a catalyst, is first applied to a side of the substrate by a thermal spray; a second predetermined surface, such as the same or a different catalyst, is then applied to the opposite side of the substrate by a physical vapor deposition process, such as electron beam evaporation or a sputtering process. Neither surface is substantially degraded during the bi-lateral surface coating process. After both sides of the substrate are surfaced, the substrate may be physically manipulated or formed into a desired shape without affecting the surface properties of the opposite sides. The invention is particularly useful in the deposition of catalyst materials on surfaces of components used in micro-component reaction chamber assemblies.

In the present invention, a catalyst composition is applied to a first substrate surface by thermal spraying and a catalyst composition is applied to the opposite substrate surface by physical vapor deposition to provide a substrate having high surface area on both sides, coated with minute particles that efficiently promote a predetermined reaction, such as steam reforming or catalytic heating, on either side of the substrate. The preferred use of the substrate is to be formed into a wavy plate separator that defines linear flow micro channels in micro component reactor or heat exchange assemblies, such as are described in co-pending application for United States Letters Patent Serial No. 09/627,267 filed on July 28, 2000 assigned to the same assignee as is this application. Surfaces or coatings, such as

chemical reactions and calcination; United States Patent No. 6,051,528 to Brezny which describes a wash coat created by dissolving cerium carbonate to form cerium acetate which is then treated by spray pyrolysis to form a ceria powder; and United States Patent No. 5,989,648 to Phillips which describes the plasma generation of supported metal catalysts. United States Patent No. 5,453,641 describes V-shaped or tapered micro-channel substrate surfaces and United States Patent No. 5,002,123 also describes V-shaped micro-channels tapered in the direction of flow of fluid through the channel. United States Patent No. 4,777,560 shows a heat sink formed of an integral element of thermally conductive material.

The surfacing of opposite sides of a metallic thin film or plate with a catalyst composition presents numerous difficulties. Disadvantages associated with teachings of the patents referenced above are encountered in the production of micro-channel reactors and heat exchange devices. For example, when a substrate surface is coated with a catalyst by means of thermal gas spraying and the molten coating on the metallic film is cooled by means of vacuum contact with a V-shaped heat sink, providing a coating on the opposite side of a substrate already having one coated surface is not possible with the prior art because of the need for contact with a heat sink. To coat an opposite side of an already coated substrate by thermal spraying is problematic because re-heating occurring during the coating of side two would cause the surface of coated side one of the substrate to melt and puddle, degrading the surface and decreasing the efficiency of the catalyst coating.

alumina, ceria and palladium, are applied to opposite sides of the substrate, which may be planar, or pre-formed into a pre-fold shape by thermal spray and vapor deposition to provide catalytic environments for reactions, such as steam reforming, water-gas-shift and oxidation, in micro component reactors.

A catalyst surface or coating is applied to a first side of the substrate, preferably by a thermal spray process. A plasma can spray materials having very high melting points. Further, the plasma sprayed surfaces achieved in the invention are generally dense, strong and clean. The thermal spray is a continuous, line of sight, directed, melt-spray process in which relatively large catalyst precursor particles (usually 15-200 μm in diameter) are melted and accelerated to high velocities in an environment of one or more than one of a combustion flame, direct current (dc), radio frequency (rf) or dc/rf hybrid non-transferred thermal plasma arc. Molten or semi-molten droplets impinge on the substrate and solidify to form a high surface area coating/surface of minute particles having catalyst properties. The surface is typically an aggregation of minute particulates in a nominal size range distribution where approximately 90% of the surface particles have diameters of less than approximately five microns (5 μm) and preferably less than approximately one micron (1 μm), deposited as a layer on the substrate, generally greater than approximately ten microns (10 μm) thick. The quantity of material deposited on the substrate surface is dependent on the degree/activity of the catalytic properties required for a predetermined application. Typically, the thickness of the catalytic surface will be in the range of from approximately thirty microns (30 μm) to approximately eighty

microns (80 μm) for a micro component micro channel reactor. For other uses, the layer may be thicker, for example, up to one millimeter (1 mm) thick, with the total amount of catalytic material applied to the surface dependent upon interrelated parameters such as surface area, the specific reactant properties and activity required on a surface and fluid flow rates associated with a particular design.

The referenced related applications describe the deposition of metal hydroxides, carbonates and nitrates and other catalyst precursors on a substrate by thermal spray processes on the first side of a substrate. During a line of sight spray process, the precursor materials decompose and oxides, metals and/or mixtures thereof are formed that adhere in a mechanically stable manner to the surface of a thin metal substrate. For example, with hydroxide, carbonate and nitrate metal compositions, the reactions respectively occur in a thermal spray process: a) $\text{Me}(\text{OH})_x \rightarrow \text{MeO}_x + \text{H}_2\text{O}$; b) $\text{Me}(\text{CO}_3)_x \rightarrow \text{MeO}_x + \text{CO}_2$; and c) $\text{Me}(\text{NO}_3)_x \rightarrow \text{MeO}_x + \text{N}_2$. Noble metal compositions are also deposited on the surface from the thermal spray of precursor compositions. In treating the first surface of the substrate, a copper heat sink vacuum system may support and cool the substrate during deposition.

The problem resolved by the present invention is coating the second side, after the first side is coated, while preserving the integrity of the first side surface. The use of physical vapor deposition on one side in a process using a thermal spray of the other side results in a bi-laterally coated member leaving the first surface intact after the second surface is treated, in

which the surfaces on both sides are chemically and/or mechanically bonded to the substrate. The substrate may then be formed into micro channel shapes and the formed member brazed to plates for use in micro component reactors.

The invention is described more fully in the drawings and the following description of the preferred embodiment.

BRIEF DESCRIPTION OF THE DRAWINGS

FIG. 1A is a representation (not to scale) of a shaped and coated thin plate substrate formed into a wavy plate separator for a micro channel separator for a micro component reactor. The opposite sides of the shaped plate are surfaced with different catalysts.

FIG. 1B is a representation (not to scale) of a section of a micro component reactor assembly having upper and lower plates enclosing a thin wavy plate separator forming micro channels on the opposite surface sides thereof. The separator is surfaced on its opposite sides with different catalysts. (The perimeter sides of the enclosure are not shown for reasons of clarity in the figure.)

FIG. 1C is a representation (not to scale) of a section of a coated thin plate with a multiple component catalyst surface on a first side.

FIG. 1D is a representation (not to scale) of a section of a coated thin plate with a single component catalyst surface on a second or opposite side.

FIG. 2A and FIG 2B are representations of alternative thermal spray deposition process for depositing a two (2) component catalyst on a substrate to provide a surfaced substrate such as shown in FIG. 1C,

showing respectively, a flat and a pre-formed substrate maintained on a heat sink during the initial deposition process.

FIG. 3 is a representation of the deposition by electron beam evaporation of a single component coating on a second surface of a substrate to provide a surfaced substrate such as shown in FIG. 1D.

FIG. 4 is a representation of the deposition by plasma sputtering of a single component coating on a second surface of a substrate to provide a surfaced substrate such as shown in FIG. 1D.

FIG. 5 shows in perspective a substrate or shim prior to treatment and shaping in accordance with the invention.

FIG. 5A, FIG. 5B, FIG. 5C and 5D represent cross sections of the sequential shapes encountered in forming a catalyst coated wavy plate separator for a micro channel micro component reactor beginning with a flat plate and using a curvilinear pre-folded shape that is formed into the wavy plate separator in a micro component reactor..

FIG. 6A, FIG. 6B, FIG. 6C and 6D represent sequential shapes encountered in forming a catalyst coated wavy plate separator for a micro channel micro component reactor using an angularly pre-folded shape.

DESCRIPTION OF THE INVENTION AND THE BEST MODE

The present invention provides a bilaterally treated substrate useful, *inter alia*, as an improved separator or wavy plate for a micro channel reactor and a method for treating or providing surfaces on the two opposite sides of a thin film or wavy plate substrate. A substrate is coated on first and second surfaces. The first surface consists of one or more than one of cerium oxide,

aluminum oxide, tin oxide manganese oxide, copper oxide, cobalt oxide, nickel oxide, praseodymium oxide, terbium oxide, ruthenium, rhodium, palladium, silver, iridium, platinum and gold. The second surface consists of one or more than one of ruthenium, rhodium, palladium, silver, iridium, platinum and gold. The first surface comprises particles having a nominal diameter size distribution in which approximately 90% of the particles have a diameter in the approximate range of < 5 microns and preferably < 1 micron; the second surface comprises a coating having a nominal thickness of < 100 nanometers. The base substrate is a thin metallic film, preferably a nickel-based alloy which may be treated flat or with pre-folds having apexes spaced apart a predetermined distance corresponding to the apexes in a folded member that forms channels of a predetermined side separation and depth, such as a separator wavy plate in a micro channel reactor. The folds may be curvilinear or angular. In an example, the first surface consists of a ceria and palladium catalyst and the second/opposite surface consists of a palladium catalyst. Characteristics of the first surface applied to the substrate will typically include a thickness in the nominal range of greater than approximately thirty microns (30 μm) and a porosity of at least 50%. In another example, the second surface has an adhesion quality to the substrate that tolerates a recycling temperature in the range of 1000 °C.

In the method of the invention, opposite surfaces of a substrate are coated with catalysts in a method in which a first surface of the substrate is thermally sprayed with particulates of one or more than one of a metal hydroxide, metal carbonate, or metal nitrate particles and a noble metal,

noble metal hydroxide, noble metal carbonate, or noble metal nitrate to produce a first catalyst composition thereon, and the opposite surface of the substrate is coated by electron beam deposition with one or more than one of ruthenium, rhodium, palladium, silver, iridium, platinum and gold to produce a second catalyst composition thereon. The second surface may be cleaned by an ion-gun in an oxygen atmosphere and in an argon atmosphere prior to deposition. The substrate may be supported upon a substantially rigid heat sink in which the opposite surface of the substrate is in contact with a heat sink during the thermal spraying of the first surface.

When used in the making of a micro channel catalytic device, the substrate is pre-formed with longitudinal folds spaced a predetermined distance apart corresponding to predetermined apexes of micro channels having a predetermined depth. Stamping an initially flat shim, sheet or plate material to produce curvilinear folds such as shown in FIG. 5B is a preferred pre-form method. The first surface of the substrate is thermal sprayed with particulates of one or more than one of a metal hydroxide, metal carbonate, or metal nitrate particles and a noble metal, noble metal hydroxide, noble metal carbonate, or noble metal nitrate to produce a first catalyst composition thereon. The opposite surface of the substrate is coated by electron beam deposition with one or more than one of ruthenium, rhodium, palladium, and silver, iridium, platinum and gold to produce a second catalyst composition thereon. The so surfaced substrate is then squeezed laterally such that the preformed folds of the substrate narrow in the separation distance between adjacent, facing side sections, from their

apexes to form micro channels with a high depth to width aspect ratio. In one aspect, the preformed substrate is supported in contact with a substantially rigid heat sink having an upper surface with a shape corresponding to an underside of the pre-folded substrate during the step of thermal spraying. The opposite side is then surfaced with a catalyst composition. After being so treated, the scored or pre-folded substrate is squeezed from opposite lateral sides to narrow the longitudinal separations between the folds to form a wavy plate separator. Apexes on the opposite sides of the folded/squeezed substrate are brazed to upper and lower plates to form the enclosed channels of a micro reactor assembly. In the method, the first surface may be grit-blasted prior to thermal spraying and the electron beam deposition on the second surface is preferably performed subsequent to the thermal spraying of the first surface.

The present invention provides a first surface catalytic substrate surface comprising a particulate coating of a) one or more than one of cerium, aluminum, tin, manganese, copper, cobalt, nickel, praseodymium or terbium oxide and b) one or more than one of ruthenium, rhodium, palladium, silver, iridium, platinum and gold, characterized as a substantially uniform distribution over the surface of the substrate in which the coating particles are in the nominal diameter size distribution range of < 5 microns, preferably, in the nominal diameter size distribution range of < 2 or 3 microns. Most preferably, the coating particles are in the nominal diameter size distribution range of < 1 micron, namely, 90% of the particles in the distribution have a diameter less than 1 micron. Smaller particle sizes at the

surface optimize the desired catalyst characteristics of the substrate (e.g., enhanced surface area) achieved by the invention. The catalytic surface coating is produced by thermal spraying a mixture of large size particles (e.g., in a nominal size distribution range of > 10 micrometers to 200 micrometers or more, limited by the nozzle spray orifice of the thermal spray) of hydroxides, carbonates or nitrates of the metals, cerium, aluminum, tin, manganese, copper, cobalt, nickel, praseodymium or terbium and the hydroxides, carbonates or nitrates of the noble metals, ruthenium, rhodium, palladium, silver, iridium, platinum and gold onto the substrate.

The first surface is sprayed with metal oxide precursors, preferably cerium carbonate or cerium hydroxide, which become a ceria coating on a metal surface; and a noble metal catalyst, which is deposited on the surface in the same operation. Large particle cerium carbonate is oxidized to cerium oxide, $Ce_2(CO_3)_x \cdot XH_2O \rightarrow Ce_2O_3 + 3CO_2 + XH_2O$. In the presence of air or oxygen, Ce_2O_3 is oxidized to CeO_2 , namely, $Ce_2O_3 + \frac{1}{2}O_2 = 2CeO_2$. After the thermal spraying, if a substantial quantity of Ce_2O_3 is present on the substrate surface, an after-treatment may be applied to achieve the correct phase of CeO_2 . In the process, the large size particles decompose, the water component vaporizes and a ceria/noble metal mixture coating on the substrate surface results.

In an embodiment, a mixture of noble metal component particles are injected into a thermal spray to produce a catalyst coating of metal oxide / noble metal having a nominal particle size diameter distribution in the range of < 5 microns, particularly < 2 or 3 microns, and more preferably < 1 micron

(In the ranges stated herein, a particular distribution includes approximately 90% of the particles within the parameter stated.) on a first surface of a substrate, preferably, a thin metallic film. In an embodiment, the metal oxide / noble metal particulate surface mixture is ceria / palladium. After cooling, the second surface of the substrate is coated, preferably by physical vapor deposition, such as electron-beam evaporation or plasma sputtering, with a noble metal, such as palladium. In an embodiment, the second surface is deposited after the cooling of the first surface. A physical vapor deposition method for the second surface allows the first surface coating to remain intact. The invention provides a two-sided micro-channel with a first surface having a porous, fine particle coating of a mixture of metal oxides and noble metals, having good mechanical adhesion to a substrate surface and stability properties and surface characteristics useful for catalytic reactor applications; and a second surface coated with a noble metal oxidation catalyst for converting hydrocarbons to heat energy.

In an example, the substrate is a chromium - nickel super alloy such as Inconel® is roughened by grit blasting prior to thermal spraying. The substrate may be flat, or preformed in a curvilinear or angular folded accordion-like shape, prior to the thermal spray. The first surface of the substrate is coated with a catalyst by plasma-spray. The coating used in an embodiment is a mixture of ceria and palladium. In an alternate embodiment the noble metal is deposited on the same surface by physical vapor deposition after the deposition of ceria. The substrate is positioned on a copper block by means of a low vacuum. In an embodiment such as shown

in FIG. 2B, the support/cooling block corresponds to the pre-formed shape of the substrate. The block cools the substrate during spraying by means of a coolant system such as by water flow through channels in the support block.

After the thermal spraying, the second (or opposite) side of the substrate is coated with a noble metal, such as ruthenium, rhodium, palladium, silver, iridium, platinum or gold. In an embodiment, palladium is deposited by electron beam evaporation. The second surface is cleaned with an ion-gun using 5 minutes of oxygen and 10 minutes of argon. In one example, the evaporation of palladium by e-beam is at a rate of 1\AA per second and the coatings of palladium may be applied in a thickness of from approximately five nanometers (5 nm) to approximately ninety nanometers (90 nm). The surfaces are sufficiently adhesive to withstand a temperature up to approximately 1000°C . To be optimized for a particular application, the criterion of material cost of a noble metal is balanced with the degree of catalytic activity desired in a particular process environment. With a noble metal, a surface thickness of one hundred nanometers (100 nm) appears to be the economically practical upper limit for a substrate so processed employed as a separator in a micro channel micro component reactor such as described in the above referenced application for United States Letters Patent Serial No. 09/627,267 filed on July 28, 2000.

With reference to the drawings, a shaped and coated thin plate substrate 1 having opposite sides 1A and 1B is shown in FIG. 1A, formed as a wavy plate separator for forming micro channels in a micro component reactor. Apexes of the folds are shown at A1, A2, A3 and A4. The opposite

sides of the shaped plate are surfaced with different catalysts, side 1A, for example, surfaced with a mixture of ceria 2 and palladium 3, and side 1B surfaced with palladium 4. In the reactor, fluid flows FA and FB are introduced on opposite sides 1A and 1B of the separator. FIG. 1B illustrates the wavy plate with apexes A1, A2, A3 and A4 of the folded substrate 1 brazed to upper 5 and lower 6 plates that enclose the opposite sides of the substrate / wavy plate, forming enclosed longitudinally extending micro channels, such as C1, C2, C3, C4, Cn for fluid flows FA and FB. The fluid flows are introduced into or exit from the reactor assembly through lateral orifices 5A and 6A transverse to the micro channels at the front and rear (not shown) of the upper and lower plates enclosing the reactor. FIG. 1C and FIG. 1D illustrate sections of the separator with different particulate coatings (or surfaces) applied to the opposite sides of the substrate. The reference numerals in FIG. 1C and FIG. 1D identify comparable elements identified with the same numerals in FIG. 1A.

FIG. 2A and FIG. 2B are representations of the thermal spray processes (not to scale) in which large size particle precursor materials 8 and 9 are introduced through orifices 21 and 22 into a plasma 20 directed onto the first side surface 11 of a substrate 10 maintained by vacuum 25 on a supporting and complementarily shaped heat sink 15 having a coolant system 26. The plasma spray of the precursor particles 8 and 9, as the substrate is manipulated 10M so that its surface area is exposed to the spray, results in the deposit on the first side surface 11 of a mixture of small size catalyst particles 12. Above referenced application for United States

Letters Patent Serial No. 09/912,223 filed on July 24, 2001 and application for Letters Patent Serial No. 09/742,697 filed on December 20, 2000 describe various methods and variations of the thermal spray process employed to provide a mixture of catalyst particles on a substrate surface.

After the first surface of the substrate is coated, the opposite side surface is coated by a physical deposition method. In FIG. 3, an enclosure 30 interconnected 31 with a vacuum pump provides a vacuum chamber 32 for maintaining the substrate 10, having a first side surface 11 already applied thereon, therein. The substrate 10 is shown in a pre-folded configuration. The chamber also contains electrode 33 and container 34 for holding therein a noble metal material 35 which is vaporized, when a suitable electron beam field is generated between electrode 33 and noble metal 35. The noble metal vapor 36 is directed to the underside 14 of the substrate 10 already having a catalyst 12 deposited thereon.

FIG. 4 illustrates an alternate surfacing method in a vacuum chamber 40 configured similarly to the chamber 32 described above. In the chamber, the substrate 10 is supported such that noble metal vapor 42 created by plasma sputtering from source 41 is deposited on the under/opposite side 14 of substrate 10.

FIG. 5 illustrates a beginning shim, foil or flat plate substrate 50 having opposite first 51 and second 52 surfaces to be treated in accordance with the invention. In an example for use in a typically micro channel micro component reactor assembly, the substrate will be an Inconel[®] metal alloy material approximately one hundred microns (100 μ m) thick, approximately

355 millimeters in length and 60 millimeters in width. FIG. 5A illustrates a cross section of the beginning substrate. The first surface 51 of the substrate may be treated flat or pre-formed. FIG. 5B shows a substrate pre-formed in a curvilinear wave shape by a stamping process with preliminary folds at apexes 53, 54, 55, 56, 57, 50n, *etc.*, forming approximately 45° to 75°, with 60° preferred, angles between the adjacent folded sections.. Each side 51 and 52 of the pre-folded substrate is coated with catalyst material, respectively by thermal spray and physical deposition as described above. The pre-folded substrate is then laterally squeezed to narrow the separations between adjacent folds as determined by the apexes to form micro channel precursors 51c and 52c as shown in FIG. 5C. As shown in FIG. 5D, the squeezed substrate (having a greater width to depth aspect ratio) is then brazed at the apexes to upper plate 58 and lower plate 59 in an enclosure (not shown in the drawing) adapted to form adjacent and separated micro channels for fluid flow in a micro component reactor. See Application for Letters Patent of the United States Serial No. 09/627,267 filed on July 28, 2000, *supra*.

FIG. 6A, FIG. 6B, FIG. 6C and FIG. 6D represent sequential shapes encountered in forming a catalyst coated wavy plate separator for a micro channel micro component reactor using an angularly shaped pre-folded substrate in an alternative to the curvilinear shape shown in FIG. 5B, FIG. 5C and FIG. 5D. In FIG. 6A, an angular shaped wavy plate precursor is formed having apexes 63, 64, 65, 66, 67, 60n, *etc.*, treated to deposit the desired catalyst surfaces on each opposite side, then squeezed as shown in

FIG. 6C to narrow the distances between adjacent folds, and brazed to upper plate 68 and lower plate 69 in the micro component micro channel reactor enclosure to form reactive fluid flow channels. In pre-forming or squeezing the folds, the brittle ceria/metal surface on the substrate does not detach or otherwise deteriorate and the adhesion of both the ceria/metal and noble metal catalysts to the substrate is not adversely affected by the forming or squeezing process

In the invention, a thermally sprayed coating on a first side of a substrate yields a thin layer of a catalyst coating with small particle size and high surface area. In an embodiment, the method is applied to form a catalyst coating on a channel separator element used in a micro-component heat exchanger / reactor unit used in laminar flow reactors for hydrogen production devices employed in conjunction with low power fuel cells in automotive or mobile or other equivalent applications. See United States application for Letters Patent No. 09/627,267 filed on July 28, 2000, entitled "Multi-purpose Micro-channel Micro-component," assigned to the assignee of the present application, the disclosure of which is hereby incorporated by reference.

The overall process of forming such a micro component includes steps from substrate preparation to substrate surface modification to the application of a coating on the first surface by thermal spraying to produce a metal oxide and noble metal catalyst on the substrate. A flat substrate as shown in FIG. 5A or FIG. 6A or a pre-formed substrate, such as the corrugated shim precursor to a wavy plate shown in FIG. 5B and FIG. 6B is

subjected to surface grit blasting or like treatment (before or after the formation of partial folds) The substrate is positioned to receive the thermal spray as shown in FIG. 2A or FIG. 2B, preferably mounted on a heat sink to maintain a low temperature in the substrate material. Catalyst precursors are injected into a thermal spray and oxide/metal oxide/metal catalyst is deposited on the substrate surface by the spray.

The thermal sprayed coating bonds directly with the surface of the substrate. Desirable characteristics, including high porosity, high surface profile and surface area and small particle size, are beneficially achieved in the thermally sprayed coating. A catalyst precursor material, preferably a mixture of multiple materials, in the form of a particulate, powder or granule having a large particle size, for example, in a scale greater than about approximately ten micrometers (10 micro) and up to about several hundred or more micrometers (approximately 200 micro) is thermally sprayed onto the substrate and forms a catalyst coating that bonds to the substrate surface. The coating is formed from decomposition products of the sprayed mixture material and is characterized as a distribution of small size particles, namely in the order of less than approximately five microns (5 μm) in nominal diameter, preferably in the order of less than approximately two microns (2 μm) or three microns (3 μm) in nominal diameter, and more preferably in the order of less than approximately one micron (1 μm) in nominal diameter. Although the substrate may be coated sequentially in multiple layers beginning with a ceria foundation, followed by a further

coating of a catalytic material, such as a noble metal, a mixture of both compositions is preferred to be thermally sprayed in the same operation.

The catalyst formed in the thermal spray process and subsequent treatment, if any, promotes a chemical reaction when a reagent fluid flows through the channels of the micro-component device. One or both surfaces of the wavy plate separator may be treated. In this aspect of the invention, the coatings, and the enhanced surface properties thereof, also assist in the transfer of heat between adjacent channels in the micro-component device. In the invention, large size particles, or a mixture of large size particles comprising a catalyst precursor, are flame sprayed or plasma sprayed onto a substrate to produce a small particle size coating by a pyrolysis process in which heat decomposes the sprayed material. Before thermal spraying, the substrate surface may be enhanced by methods such as grit blasting and/or chemical treatment to improve adhesion of the thermally sprayed coating to the substrate.

After the deposition of the first surface coating, the process continues with the deposition of a second surface coating. The second surface in an embodiment is opposite of the first surface. Physical vapor deposition such as by electron-beam evaporation shown in FIG. 3 or plasma sputtering shown in FIG. 4 is used as a coating method for the second surface to deposit a noble metal, preferably, palladium. Alternatively, the vapor deposition may be accomplished first followed by the thermal spraying the heat sink used in the thermal spray process maintains a relatively low temperature of the substrate such that the metal coating is not likely to be

affected. As a result of this process, squeezing the substrate to form the micro channel precursors produces no brittle areas or flaking of the coatings.

In a typical micro channel micro component for a steam reformer or water-gas-shift reactor, the first side of the substrate forms one set of channels having a surface catalyst for converting fuels to hydrocarbons and the second side of the substrate forms the opposite set of channels having a catalyst surface for oxidizing hydrocarbons to heat energy.

Having described the invention in detail, those skilled in the art will appreciate that, given the present disclosure, modifications may be made to the invention without departing from the spirit of the inventive concept herein described. Rather, it is intended that the scope of the invention be determined by the appended claims.

CLAIMS:

1. A substrate comprising first and second surfaces, the first surface consisting of one or more than one of cerium oxide, aluminum oxide, tin oxide, manganese oxide, copper oxide, cobalt oxide, nickel oxide, praseodymium oxide, terbium oxide, ruthenium, rhodium, palladium, silver, iridium, platinum and gold, the second surface consisting of one or more than one of ruthenium, rhodium, palladium, silver, iridium, platinum and gold.
2. The substrate of claim 1 in which the first surface comprises particles having a nominal diameter size distribution range of < 1 micron.
3. The substrate of claim 1 in which the second surface comprises a coating having a nominal thickness of < 100 nanometers.
4. The substrate of claim 1 or claim 2 or claim 3 comprising a thin metallic film having first and second surfaces.
5. The substrate of claim 4 comprising a nickel-based alloy.
6. The substrate of claim 1 including a plurality of folds.

7. The substrate of claim 6 in which the folds are spaced apart a predetermined distance corresponding to predetermined apexes in a folded member forming channels of a predetermined depth.
8. The substrate of claim 6 in which the folds are curvilinear.
9. The substrate of claim 6 in which the folds are angular.
10. The substrate of claim 6 in which the folds are formed in the substrate by stamping.
11. The substrate of claim 1 in which the first surface consists of ceria and palladium.
12. The substrate of claim 1 in which the second surface consists of palladium.
13. The substrate of claim 1 in which the first surface has a thickness in the nominal range of greater than approximately thirty microns (30 μm).
14. The substrate of claim 1 in which the first surface has a porosity of at least 50%.

15. The substrate of claim 1 in which the adhesion of the second surface tolerates a processing temperature up to approximately 1000 °C.
16. A method of providing different catalyst surfaces on the opposite surface sides of a substrate comprising:
- thermal spraying one surface of the substrate with particulates of one or more than one of a metal hydroxide, metal carbonate, or metal nitrate particles and a noble metal, noble metal hydroxide, noble metal carbonate, or noble metal nitrate to produce a first catalyst composition thereon, and
 - coating a surface of the substrate opposite the one surface by a physical deposition process with one or more than one of ruthenium, rhodium, palladium, silver, iridium, platinum and gold to produce a second catalyst composition thereon.
17. The method of claim 16 in which a surface to be coated by a physical deposition process is cleaned by an ion-gun in an oxygen atmosphere and in an argon atmosphere prior to deposition.
18. The method of claim 16 wherein the substrate is supported upon a substantially rigid heat sink conforming to the shape of the substrate during the thermal spraying of the one surface.

19. The method of claim 16 in which the thermal spraying of the one surface precedes the physical deposition of a metal composition on the surface opposite the one surface.

20. The method of claim 16 in which coating the opposite surface of the substrate by a physical deposition process comprises an electron beam vapor deposition of a noble metal composition.

21. The method of claim 16 in which coating the opposite surface of the substrate by a physical deposition process comprises plasma sputtering a noble metal composition.

22. A method of making a micro channel catalytic device comprising:
pre-forming a substrate with longitudinal folds spaced a predetermined distance apart corresponding to predetermined apexes of micro channels having a predetermined depth;

thermal spraying one surface of the substrate with particulates of one or more than one of a metal hydroxide, metal carbonate, or metal nitrate particles and a noble metal, noble metal hydroxide, noble metal carbonate, or noble metal nitrate to produce a first catalyst composition thereon;

coating the surface of the substrate opposite the one surface by a physical deposition process with one or more than one of ruthenium, rhodium, palladium, silver, iridium, platinum and gold to produce a second catalyst composition thereon.

23. The method of claim 22 for making a micro channel catalytic device further comprising the step of squeezing the substrate laterally such that the preformed folds of the substrate narrow from their apexes to form the micro channels.

24. The method of claim 22 in which the pre-forming of the substrate with longitudinal folds comprises stamping the folds into a sheet material.

25. The method of claim 22 in which the preformed substrate is supported during the step of thermal spraying in contact with a substantially rigid heat sink having an upper surface with a shape corresponding to the supported side of the pre-folded substrate .

26. The method of claim 22 further including brazing the apexes of the folds on each side of the substrate to a plate to form enclosed channels defined by the apexes of the folds.

27. The method of claim 16 or claim 22 in which the one surface is grit-blasted prior to thermal spraying.

28. The method of claim 16 or claim 22 in which the physical deposition of a noble metal on the surface is performed subsequent to the thermal spraying of the one surface.

29. A micro component micro channel catalytic heat exchange device produced in accordance with claim 16 or claim 22.

FIG. 1A

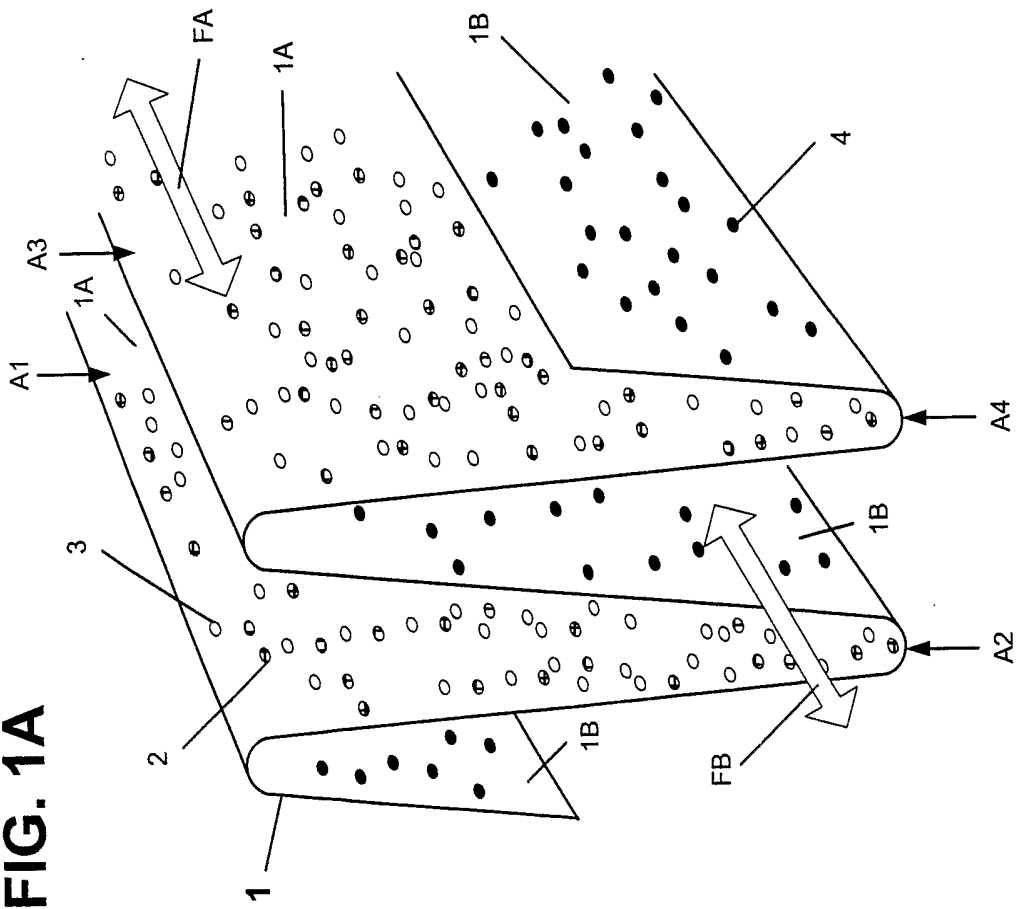
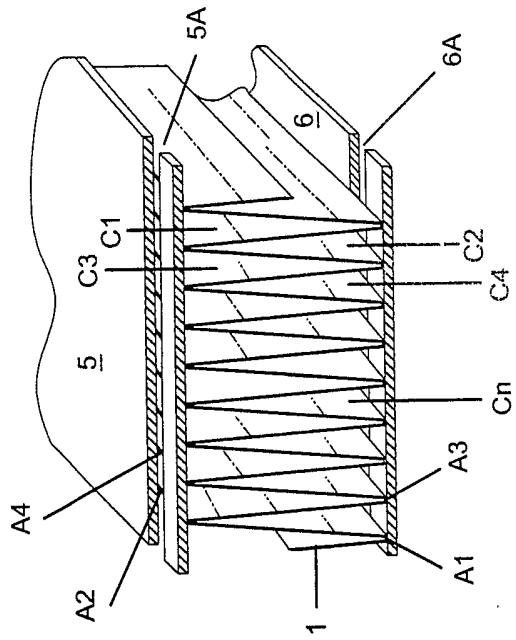
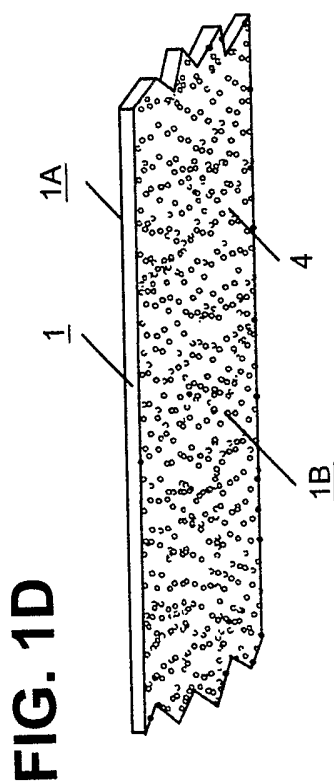
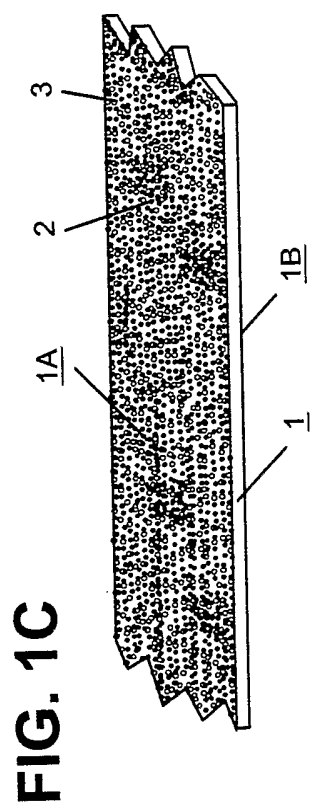

FIG. 1B





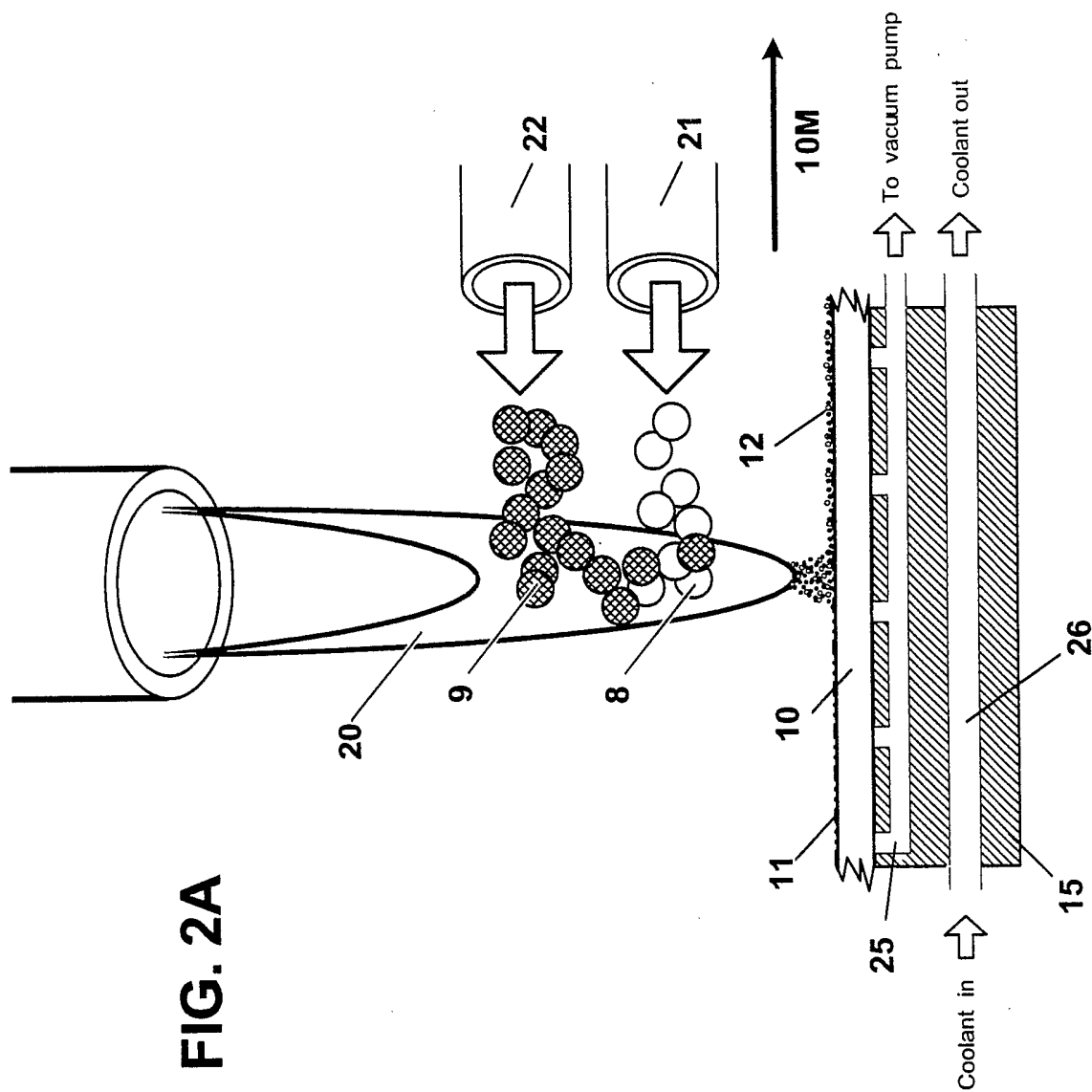
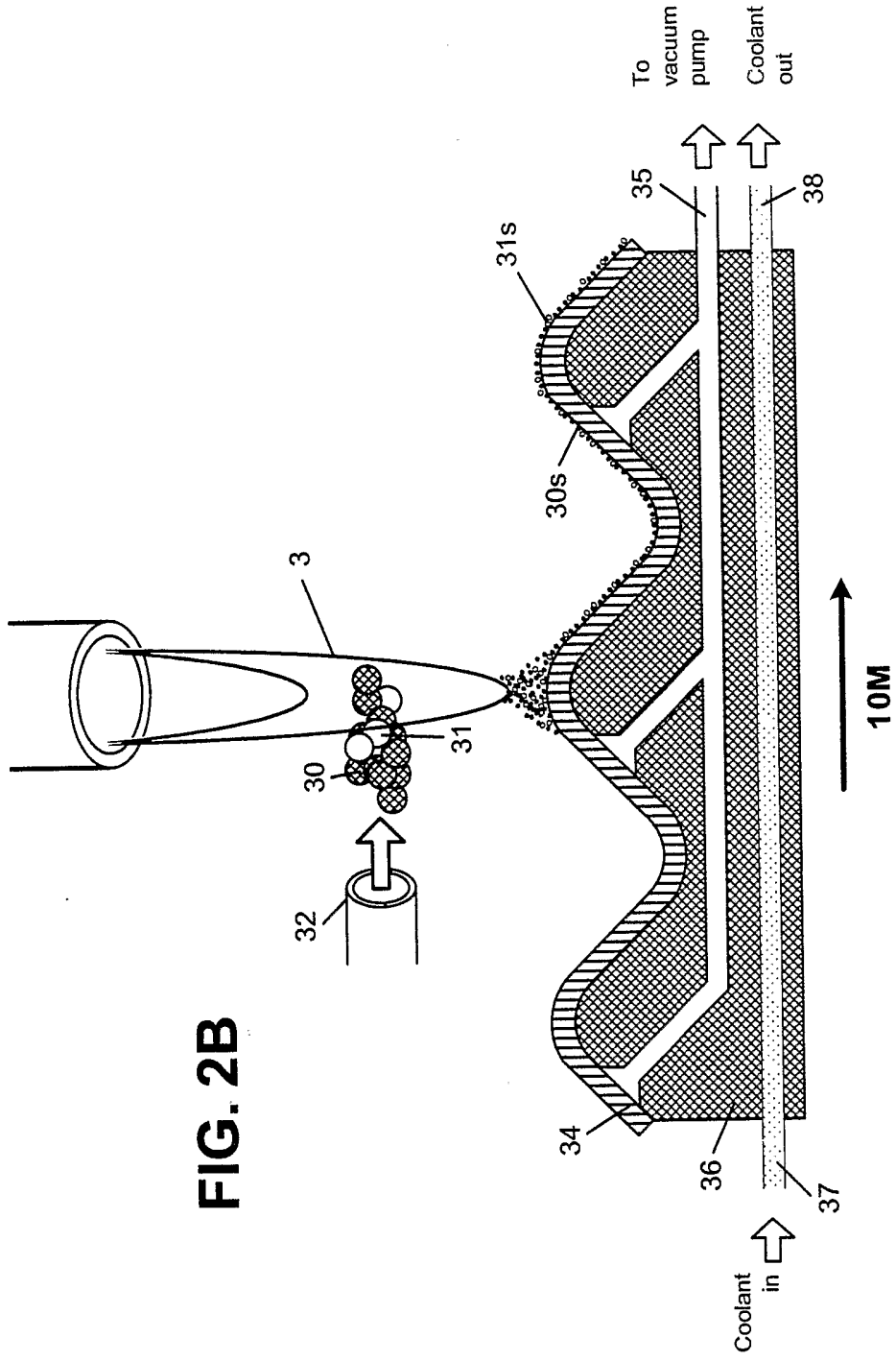
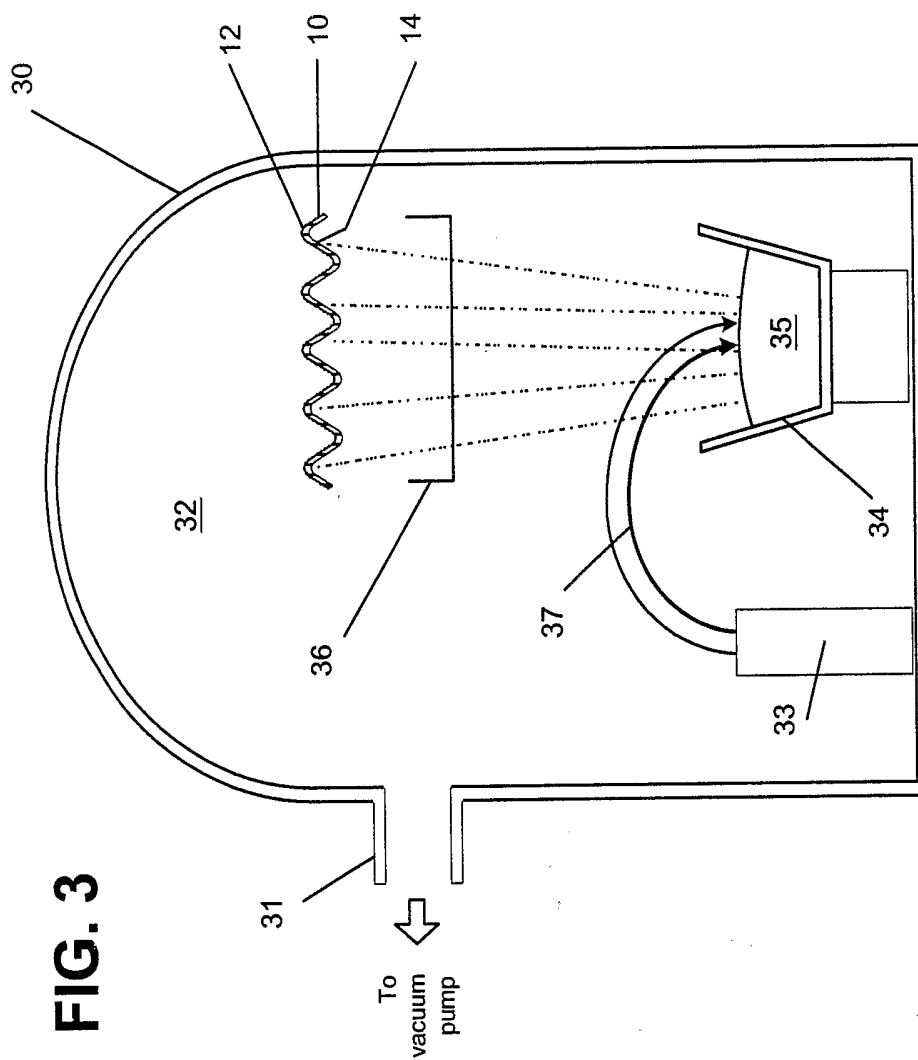

FIG. 2A





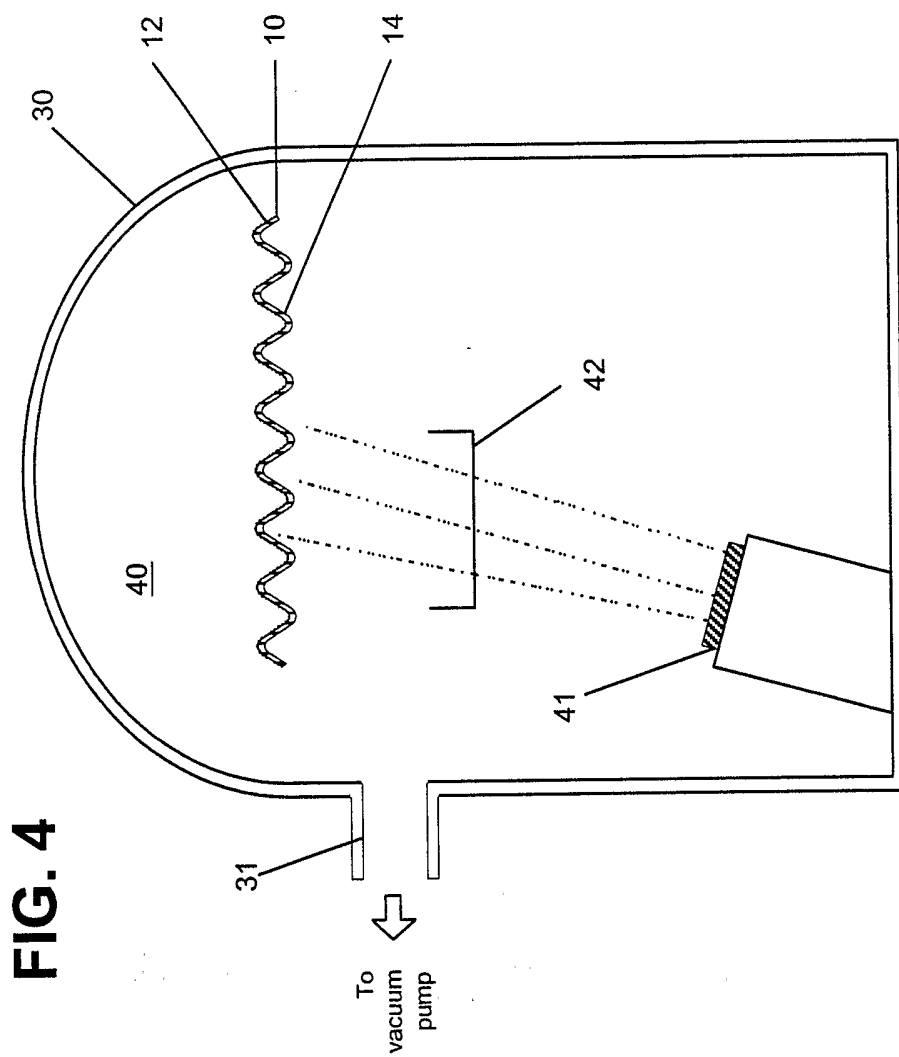

FIG. 4

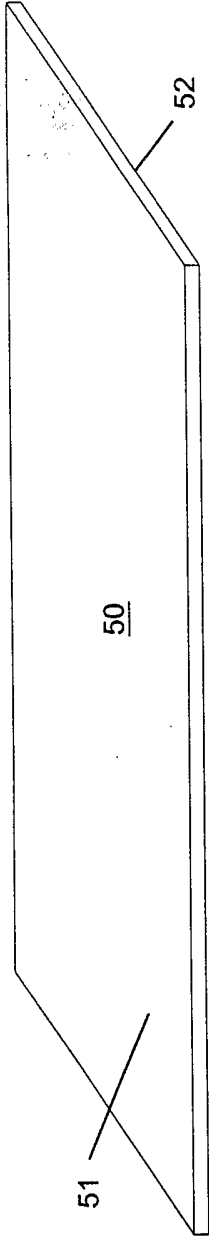

FIG. 5

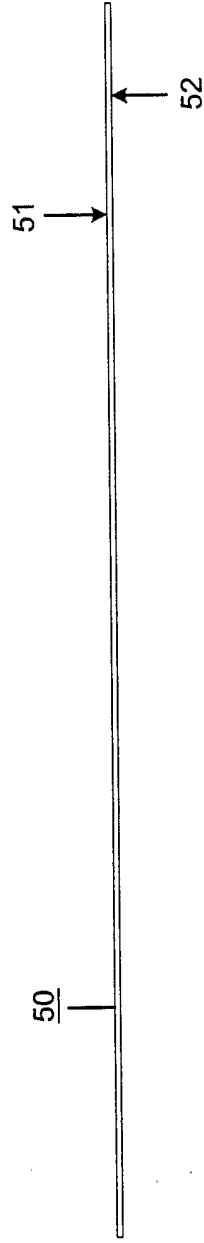

FIG. 5A

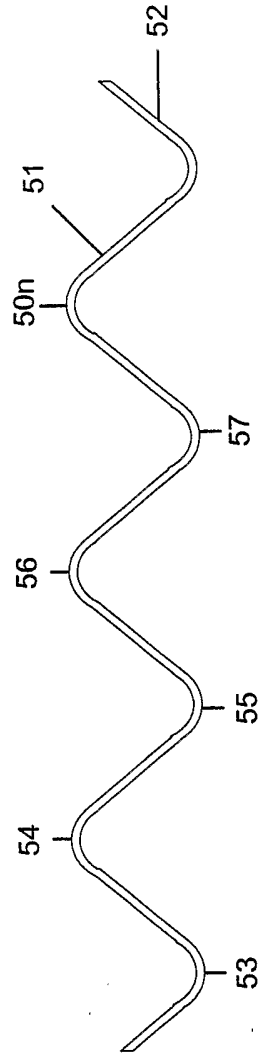

FIG. 5B

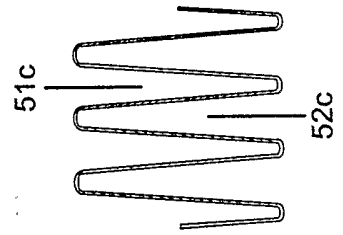

FIG. 5C

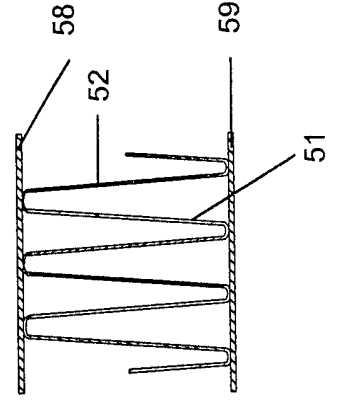

FIG. 5D

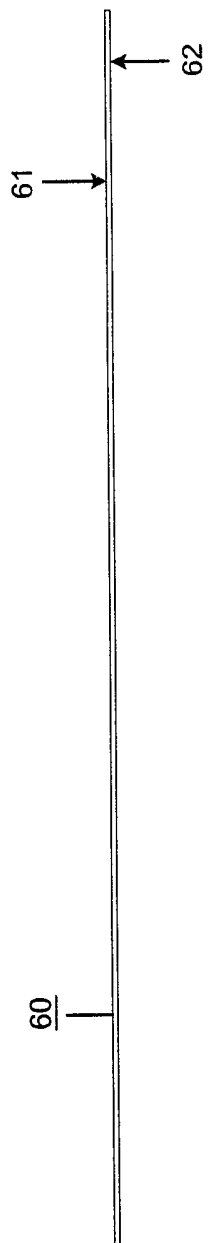

FIG. 6A

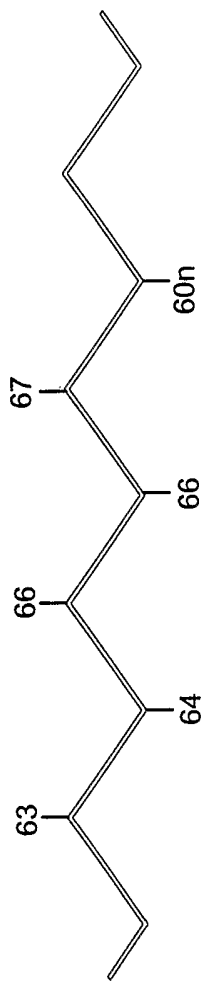

FIG. 6B

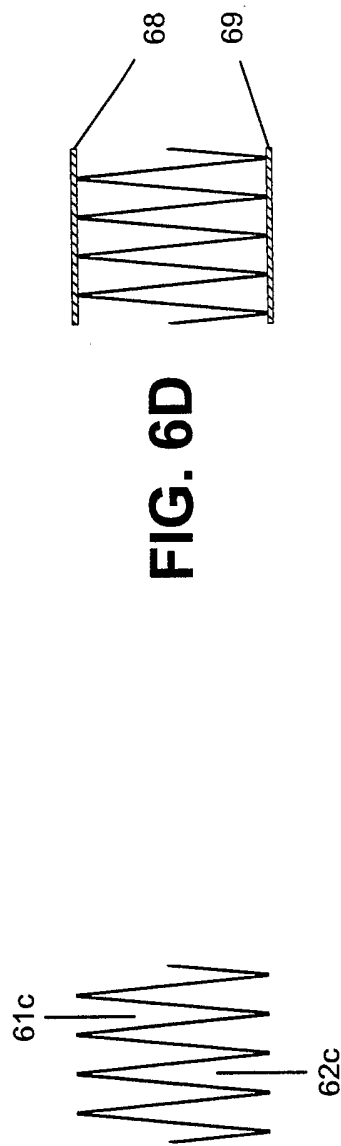



FIG. 6C

FIG. 6D

INTERNATIONAL SEARCH REPORT

International application No.
PCT/US02/29439

A. CLASSIFICATION OF SUBJECT MATTER		
IPC(7) :Please See Extra Sheet. US CL :Please See Extra Sheet. According to International Patent Classification (IPC) or to both national classification and IPC		
B. FIELDS SEARCHED		
Minimum documentation searched (classification system followed by classification symbols) U.S. : Please See Extra Sheet.		
Documentation searched other than minimum documentation to the extent that such documents are included in the fields searched		
Electronic data base consulted during the international search (name of data base and, where practicable, search terms used)		
C. DOCUMENTS CONSIDERED TO BE RELEVANT		
Category*	Citation of document, with indication, where appropriate, of the relevant passages	Relevant to claim No.
X	US 6,183,543 A (BUXBUAM) 06 February 2001, see entire document.	1, 5-7, 10, & 12
Y	US 5,958,440 A (BURRELL et al) 28 September 1999, see entire document.	1-29
A	US 4,968,529 A (HAMAMURA et al) 06 November 1990, see entire document.	1-29
A	US 3,935,351 A (FRANZ) 27 January 1976, see entire document.	1-29
A	US 3,944,440 A (FRANZ) 16 March 1976, see entire document.	1-29
A	US 5,770,255 A (BURRELL et al) 23 June 1998, see entire document.	1-29
<input checked="" type="checkbox"/> Further documents are listed in the continuation of Box C. <input type="checkbox"/> See patent family annex.		
* "A" "E" "L" "O" "P"	Special categories of cited documents: document defining the general state of the art which is not considered to be of particular relevance earlier document published on or after the international filing date document which may throw doubts on priority claim(s) or which is cited to establish the publication date of another citation or other special reason (as specified) document referring to an oral disclosure, use, exhibition or other means document published prior to the international filing date but later than the priority date claimed	"T" later document published after the international filing date or priority date and not in conflict with the application but cited to understand the principle or theory underlying the invention "X" document of particular relevance; the claimed invention cannot be considered novel or cannot be considered to involve an inventive step when the document is taken alone "Y" document of particular relevance; the claimed invention cannot be considered to involve an inventive step when the document is combined with one or more other such documents, such combination being obvious to a person skilled in the art "&" document member of the same patent family
Date of the actual completion of the international search 18 DECEMBER 2002		Date of mailing of the international search report 09 JAN 2003
Name and mailing address of the ISA/US Commissioner of Patents and Trademarks Box PCT Washington, D.C. 20231 Facsimile No. (703) 305-3230		Authorized officer CAM NGUYEN  Telephone No. (703) 308-0661

INTERNATIONAL SEARCH REPORT

International application No.
PCT/US02/29439

C (Continuation). DOCUMENTS CONSIDERED TO BE RELEVANT		
Category*	Citation of document, with indication, where appropriate, of the relevant passages	Relevant to claim No.
A	US 5,786,031 A (RETALLICK et al) 28 July 1998, see entire document.	1-29
A	US 5,250,105 A (GOMES et al) 05 October 1993, see entire document.	1-29
A	US 5,250,489 A (DALLA BETTA et al) 05 October 1993, see entire document.	1-29
A	US 5,466,651 A (PFEFFERLE) 14 November 1995, see entire document.	1-29

INTERNATIONAL SEARCH REPORT

International application No.
PCT/US02/29489

A. CLASSIFICATION OF SUBJECT MATTER:

IPC (7):

B01J 23/00, 23/40, 23/42, 23/58, 23/72, 23/56, 23/44, 23/02, 23/04, 23/70, 23/50, 23/08, 21/04; C23C 4/10, 4/08;
B05D 1/04, 5/12.

A. CLASSIFICATION OF SUBJECT MATTER:

US CL :

502/325, 326, 327, 330, 331, 332, 333, 334, 335, 337, 339, 344, 345, 346, 347, 348, 352, 355, 439; 427/453, 456, 471,
123, 124, 125, 126.6.

B. FIELDS SEARCHED

Minimum documentation searched

Classification System: U.S.

502/325, 326, 327, 330, 331, 332, 333, 334, 335, 337, 339, 344, 345, 346, 347, 348, 352, 355, 439; 427/453, 456, 471,
123, 124, 125, 126.6.