

(12) STANDARD PATENT
(19) AUSTRALIAN PATENT OFFICE

(11) Application No. **AU 2014218319 B2**

(54) Title
Paint container

(51) International Patent Classification(s)
B44D 3/12 (2006.01) **B65D 23/06** (2006.01)

(21) Application No: **2014218319** (22) Date of Filing: **2014.02.13**

(87) WIPO No: **WO14/124488**

(30) Priority Data

| | | |
|-------------------|-------------------|--------------|
| (31) Number | (32) Date | (33) Country |
| 2013900468 | 2013.02.14 | AU |

(43) Publication Date: **2014.08.21**

(44) Accepted Journal Date: **2017.04.27**

(71) Applicant(s)
Allen Patrick Zimdahl

(72) Inventor(s)
Zimdahl, Allen Patrick;Khoury, Edward Joseph

(74) Agent / Attorney
Armour IP, PO Box 3099, Broadway Nedlands, WA, 6009, AU

(56) Related Art
US 332043 A
US 4279355 A



- (51) International Patent Classification:
B44D 3/12 (2006.01) *B65D 23/06* (2006.01)
- (21) International Application Number:
PCT/AU2014/000116
- (22) International Filing Date:
13 February 2014 (13.02.2014)
- (25) Filing Language: English
- (26) Publication Language: English
- (30) Priority Data:
2013900468 14 February 2013 (14.02.2013) AU
- (72) Inventor; and
- (71) Applicant : **ZIMDAHL, Allen Patrick** [AU/AU]; 610 Hill Rd, Parkerville, Western Australia 6081 (AU).
- (72) Inventor: **KHOURY, Edward Joseph**; 19 Scoutler Way, Bateman, Western Australia 6150 (AU).
- (74) Agent: **HOLLIDAY, Neal Joseph**; c/- Armour IP, PO Box 3099, Broadway Nedlands, Western Australia 6009 (AU).
- (81) Designated States (unless otherwise indicated, for every kind of national protection available): AE, AG, AL, AM,

AO, AT, AU, AZ, BA, BB, BG, BH, BN, BR, BW, BY, BZ, CA, CH, CL, CN, CO, CR, CU, CZ, DE, DK, DM, DO, DZ, EC, EE, EG, ES, FI, GB, GD, GE, GH, GM, GT, HN, HR, HU, ID, IL, IN, IR, IS, JP, KE, KG, KN, KP, KR, KZ, LA, LC, LK, LR, LS, LT, LU, LY, MA, MD, ME, MG, MK, MN, MW, MX, MY, MZ, NA, NG, NI, NO, NZ, OM, PA, PE, PG, PH, PL, PT, QA, RO, RS, RU, RW, SA, SC, SD, SE, SG, SK, SL, SM, ST, SV, SY, TH, TJ, TM, TN, TR, TT, TZ, UA, UG, US, UZ, VC, VN, ZA, ZM, ZW.

- (84) Designated States (unless otherwise indicated, for every kind of regional protection available): ARIPO (BW, GH, GM, KE, LR, LS, MW, MZ, NA, RW, SD, SL, SZ, TZ, UG, ZM, ZW), Eurasian (AM, AZ, BY, KG, KZ, RU, TJ, TM), European (AL, AT, BE, BG, CH, CY, CZ, DE, DK, EE, ES, FI, FR, GB, GR, HR, HU, IE, IS, IT, LT, LU, LV, MC, MK, MT, NL, NO, PL, PT, RO, RS, SE, SI, SK, SM, TR), OAPI (BF, BJ, CF, CG, CI, CM, GA, GN, GQ, GW, KM, ML, MR, NE, SN, TD, TG).

Published:

— with international search report (Art. 21(3))

(54) Title: PAINT CONTAINER

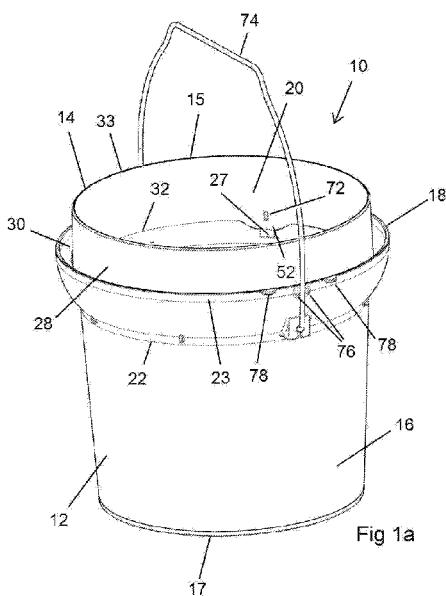

(57) Abstract: A paint container (10) comprising a main body (12) for receiving paint wherein the main body comprises a side wall (16) and an outwardly tapering rim portion (18) at an upper end of the side wall (16). A tubular member (14) is provided, a lower end of which is receivable within the rim portion (18). First connectors (26) are provided on an outer surface of the tubular member (14) and second connectors (27) are provided on an inner surface (30) of the rim portion (18). Each of the first connectors (26) engages with a corresponding one of the second connectors (27) such that the tubular member (14) is supported within the rim portion (18) to define an annular aperture between the lower end of the tubular member (14) and the main body (12) of the paint container (10).

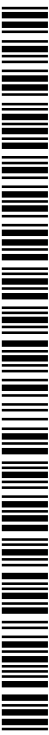

“PAINT CONTAINER”**Field of the Invention**

5 [001] The present invention relates to a container to be used for holding paint while painting.

Background to the Invention

10 [002] When painting with a brush, it is common to pour paint from a tin into a smaller container which can be carried around. While painting, the sides of the brush are often wiped on the edges of the container, in order to remove excess paint. While the aim is that this excess paint runs back into the inside of the container, there is often some amount of paint which ends up flowing down the outside of the container. This can therefore result in paint spills, through drips or from the outside of the container contacting nearby objects or the ground.

15 [003] Paint containers having a channel around the rim to collect the paint that runs outside the rim have been proposed. Such containers include holes in the channel so that paint can run back into the inside of the container. These holes may however become blocked over time. Also, the arrangement can be difficult to clean due to the spaces in which paint may collect during use.

20 [004] The present invention relates to an improved paint container aimed at overcoming, at least in part, the abovementioned problems.

Summary of the Invention

25 [005] According to one aspect of the present invention there is provided a paint container comprising:

a main body for receiving paint, the main body comprising a side wall and an outwardly tapering rim portion at an upper end of the side wall, the rim portion defining an opening into which paint can be poured;

a tubular member, a lower end of which is receivable within the rim portion;

30 first connectors provided on an outer surface of the tubular member; and

second connectors provided on an inner surface of the outwardly tapering rim portion;

wherein one of the first or second connectors comprises a protruding portion including a vertical channel therein, wherein the protruding portion protrudes
5 into the opening defined by the rim portion, and the other of the first or second connector comprises a projection extending vertically such that the projections are received into ends of the channels as the tubular member is moved downwardly into the rim portion such that the tubular member is supported within the rim portion to define an annular aperture between the lower end of
10 the tubular member and the main body of the paint container.

[006] Preferably the first connectors engage with the second connectors by movement of the tubular member towards the main body in a direction perpendicular to a central longitudinal axis of the main body.

[007] In a preferred embodiment, the first connectors each comprise a
15 protruding portion including a vertical channel therein open at a lower end and the second connectors each comprise projections extending vertically upward such that the projections are received into lower ends of the channels as the tubular member is moved downwardly into the rim portion.

[008] Preferably the projections include lugs on sides thereof adjacent the
20 central longitudinal axis of the main body and the tubular member is provided with corresponding holes located within each of the channels such that the lugs engage into the holes to locate the tubular member relative to the main body.

[009] In a further embodiment, the second connectors each comprise a
25 protruding portion including a vertical channel therein open at an upper end and the second connectors each comprise projections extending downward such that the projections are received into upper ends of the channels as the tubular member is moved downwardly into the rim portion.

[010] Preferably the projections extend downwardly from an associated cover
30 portion, the cover portions comprising a planar member extending outwardly from the outer surface of the tubular member such that the cover member extends over the upper end of the channel.

[011] In a preferred embodiment, the main body comprises a cylindrical vessel and the tubular member comprises a cylindrical member having a diameter such that the cylindrical member can be received in the opening defined by the rim portion.

5 [012] In a preferred embodiment, the rim portion tapers outwardly from adjacent a lower end thereof to the adjacent an upper end thereof to a greater degree than the taper of the cylindrical side wall.

[013] Preferably the cylindrical member is of the same diameter as that of the main body adjacent the rim portion.

10 [014] Preferably an outer diameter of the main body adjacent the lower end is less than an inner diameter of the cylindrical member such that multiple paint containers may be placed in a stacked configuration.

[015] In a preferred embodiment, the cylindrical member is received within the rim portion such that the lower end of the cylindrical member is located adjacent
15 the lower end of the rim portion and an upper end of the cylindrical member is located above the upper end of the rim portion.

[016] Preferably the first and second connectors are located at equal angular spacings around the tubular member and the rim portion.

[017] In one embodiment, a handle is provided being connectable to the main
20 body of the paint container and the rim portion is provided with securing members on outer sides thereof to engage with the handle such that the handle may be supported in one or more angular positions relative to the main body.

[018] The securing members preferably include a pair of first protrusions located adjacent the upper edge of the rim portion above the connection
25 between the handle and the rim portion such that the handle may be engaged between the first pair of protrusions to locate the handle in a vertical position.

[019] A pair of second protrusions may be provided, one on either side of the pair of first protrusions, such that the handle engages with either of the second protrusions to hold the handle at an angle between vertical and horizontal.

Brief Description of the Drawings

- 5 [020] The invention will now be described, by way of example, with reference to the following drawings, in which:
- [021] Figure 1a is an upper perspective view of a paint container in accordance with the present invention;
- [022] Figure 1b in an upper perspective view of the paint container of Figure 1a with the handle is an angled position;
- 10 [023] Figure 2a is top view of the paint container of Figure 1;
- [024] Figure 2b is a cross sectional view of the paint container of Figure 2a through the line B-B;
- [025] Figure 3a is an exploded view of the paint container of Figure 1;
- [026] Figure 3b is an upper perspective view of a plurality of the paint
15 containers of Figure 1 in a stacked configuration;
- [027] Figure 4a is an upper perspective view of a second embodiment of a paint container in accordance with the present invention;
- [028] Figure 4b is a top view of the paint container of Figure 4a;
- [029] Figure 5 is an exploded view of the paint container of Figure 4;
- 20 [030] Figure 6a is a side view of the paint container of Figure 4;
- [031] Figure 6b is a cross sectional view of the paint container of Figure 6a through the line B-B;
- [032] Figure 7 is a close up view of Detail D of Figure 6b;
- [033] Figure 8 is a side view of a plurality of the paint containers of Figure 4 in
25 a stacked configuration;
- [034] Figure 9 is an exploded view of a third embodiment of a paint container in accordance with the present invention;
- [035] Figure 10 is an upper perspective view of a fourth embodiment of a paint container in accordance with the present invention;
- 30 [036] Figure 11a is a top view of the paint container of Figure 10;
- [037] Figure 11b is a further upper perspective view of the paint container of Figure 10;
- [038] Figure 12a is a side view of the paint container of Figure 10;

[039] Figure 12b is a close up view of the connection between the tubular member and the main body of the paint container of Figure 12a through the line B-B;

5 [040] Figure 13a is a top view of a fifth embodiment of a paint container in accordance with the present invention;

[041] Figure 13b is an upper perspective view of the paint container of Figure 13a;

[042] Figure 14a is a side view of the paint container of Figure 13; and

10 [043] Figure 14b is a close up view of the connection between the tubular member and the main body of the paint container of Figure 14a through the line B-B.

Detailed Description of Preferred Embodiments

[044] Referring to Figures, there is shown a paint container 10 comprising a
15 main body 12 and a tubular member 14. The main body 12 in the embodiment shown is a generally cylindrical vessel being closed at a lower end thereof. The main body 12 comprises a cylindrical side wall 16 having a base wall 17 extending across a lower end thereof and a rim portion 18 at an upper end thereof. The side wall 16 may include a slight tapered shape such that the
20 diameter thereof adjacent the base wall 17 is less than the diameter adjacent the upper end thereof. The rim portion 18 defines an opening 20 into which paint can be poured for use when painting with a brush.

[045] The rim portion 18 of the main body 12 tapers outwardly from a lower end 22 thereof to an upper end 23 thereof such that cross sections of the rim
25 portion 18 taken perpendicular to the longitudinal axis of the main body 12 increase in area from the lower end 22 to the upper end 23. The rim portion 18 tapers outwardly from adjacent the lower end 22 to the upper end 23 to a greater degree than the taper of the side wall 16.

[046] The tubular member 14 in the embodiment shown comprises a
30 cylindrical member 15 having a diameter such that the cylindrical member 15 can be received in the opening 20 defined by the rim portion 18. The cylindrical

member 15 is received within the rim portion 18 such that a lower end 32 of the cylindrical member 15 is located adjacent the lower end 22 of the rim portion 18 and an upper end 33 of the cylindrical member 15 is located above the upper end 23 of the rim portion 18.

5 [047] The lower end 32 of the cylindrical member 15 is supported such that an annular aperture is defined between the cylindrical member 15 and the rim portion 18.

10 [048] The cylindrical member 15 is separate from the main body 12 and is attachable to the main body 12. The cylindrical member 15 is supported relative to the rim portion 18 by a plurality of first connectors 26 located around an outer surface 28 of the cylindrical member 15 and a plurality of second connectors 27 located around an inner surface 30 of the rim portion 18. The second connectors 27 are provided at locations such that each of the first connectors 26 can be engaged with a corresponding second connector 27 when the
15 cylindrical member 15 is inserted into the rim portion 18 of the main body 12.

[049] The first connectors 26 engage with the second connectors 27 by movement of the cylindrical member 15 towards the main body 12 parallel to a central longitudinal axis of the main body 12.

20 [050] In the embodiment of Figures 1 to 3, the first connectors 26 comprise female connectors and the second connectors 27 comprise male connectors. The first connectors 26 therefore include openings into which the second connectors 27 are received by movement of the cylindrical member 15 towards the main body 12 such that the cylindrical member 15 is supported relative to the main body 12.

25 [051] The first connectors 26 each comprise a protruding portion extending from the outer surface 28 of the cylindrical member 15 including a channel 36 therein. The protruding portions are located at equal angular spacings around the periphery of the cylindrical member 15. The channels 36 extend parallel to the central longitudinal axis of the cylindrical member 15 and include open lower
30 ends. The second connectors 27 each comprise projections 37 located at equal angular spacings around the inner surface 30 of the rim portion 18. The

projections 37 extend vertically upward such that the projections 37 extend parallel to the central longitudinal axis of the main body 12. The projections 37 are located such that the projections 37 may be received into lower ends of the channels 36 as the cylindrical member 15 is moved downwardly into the rim portion 18.

[052] The projections 37 are provided with lugs 70 on sides thereof adjacent the central longitudinal axis of the main body 12 of the paint container 10. The cylindrical member 15 is provided with corresponding holes 72 located within each of the channels 36 such that the holes 72 extend from the outer surface 28 of the cylindrical member 15 to an inner surface thereof. When the projections 37 are received in the channels 36, the lugs 70 engage into the holes 72 to locate the cylindrical member 15 relative to the main body 12 of the paint container 10.

[053] The lower edge of the cylindrical member 15 includes a plurality of the extending portions 52. Each of the extending portions 52 extend downwardly below the lower edge 33 of the cylindrical member 15. Each of the first connectors 26 is located on one of the extending portions 52.

[054] A handle 74 is provided being connectable to the main body 12 of the paint container 10 such that the paint container 10 may be supported by the handle 74. The handle 74 comprises a curved elongate member having opposed ends thereof secured to the outer surface of the main body 12 adjacent the lower end 22 of the rim portion 18.

[055] The rim portion 18 is provided with securing members on outer sides thereof to engage with the handle 74 such that the handle 74 may be supported in one or more angular positions relative to the main body 12. In the embodiment shown, the securing members include a pair of first protrusions 76 located adjacent the upper edge 23 of the rim portion 18 above the connection between the handle 74 and the rim portion 18. The handle 74 may be rotated such that the handle 74 engages between the first pair of protrusions 76 to locate the handle 74 in a vertical position (as shown in Figure 1a). A pair of second protrusions 78 is also provided, one on either side of the pair of first

protrusions 76. The handle 74 engages with either of the second protrusions 78 to hold the handle 74 at an angle between vertical and horizontal (as can be seen in Figure 1b).

[056] In use, the cylindrical member 15 is supported within the rim portion 18 to define the annular aperture between the cylindrical member 15 and the main body 12. As the upper end 33 of the cylindrical member 15 extends above the upper end 23 of the rim portion 18, excess paint can be removed from a paint brush by wiping across the upper end 33 of the cylindrical member 15. Paint will run down the inner surface of the cylindrical member 15 and back into the main body 12. The cylindrical member 15 is dimensioned to be of the same diameter as that of the main body 12 adjacent the rim portion 18 to allow paint to run directly down the inside wall of the main body 12.

[057] Any paint running down the outer surface of the cylindrical member 15 will simply pass through the annular aperture back into the main body 12. As this aperture is annular in shape extending around the entire rim portion 18, there is reduced chance of paint obstructing the aperture. As the cylindrical member 15 is a separate element, it may be removed from the main body 12 by disconnection of the first and second connectors 26 and 27 to allow easy cleaning of both itself and the main body 12.

[058] The outer diameter of the main body 12 adjacent the lower end is less than the inner diameter of the cylindrical member 15. Multiple paint containers 10 may therefore be placed in a stacked configuration, as shown in Figures 3b and 8, for transport and/or storage.

[059] Figures 4 to 8 show a second embodiment of a paint container 10 in accordance with the present invention. The paint container of Figures 4 to 8 is similar to the paint container 10 of Figures 1 to 3 and like reference numerals are used to denote like parts.

[060] In the embodiment of Figures 4 to 8, the second connectors 27 each comprise protruding portions defining a channel 36 being open at an upper end thereof. Each of the first connectors 26 comprises a projection 37 which can be received downwardly into the channel 36. Each projection 37 extends

downwardly from an associated cover portion 38. Each cover portion 38 comprises a planar member extending outwardly from the outer surface 28 of the cylindrical member 15. The projections 37 extend downwardly from a lower surface of the cover portion 38 such that a gap exists between the projection 37 and the outer surface of the cylindrical member 15. The cover portion 38 is provided such that it extends over the upper end of the channel 36 to prevent paint running into the channel 36.

[061] The channels 36 and the projections 37 are generally rectangular in cross sectional shape. Also, each channel 36 is provided with a rib 40 which engages with a distal end of the cover portion 38 when the cylindrical member 15 is in place. The ribs 40 engage with the cover portions 38 to secure the cylindrical member 15.

[062] Figure 9 shows a third embodiment of a paint container 10 in accordance with the present invention. The paint container 10 of Figure 9 is similar to the embodiment of Figures 4 to 8 and like reference numerals are used to denote like parts. The paint container 10 of Figure 9 includes cut out portions 60 in the lower end 32 of the cylindrical member 15. The cut out portions 60 in the embodiment shown are provided on opposed sides of the cylindrical member 15 and are arcuate in shape. The cut out portions 60 are provided to allow additional space for paint to be poured back out of the paint container 10 into a paint tin.

[063] Figures 10 to 12 show a fourth embodiment of a paint container 10 in accordance with the present invention. The paint container 10 of Figures 10 to 12 is similar to the embodiment of Figures 4 to 8 and like reference numerals are used to denote like parts. The first and second connectors 26 and 27 of the fourth embodiment comprise projections 37 and channels 36 respectively but differ from the second embodiment in shape. In the embodiment of Figures 10 to 12, the first connectors 26 each comprise a projection 37 having a T-shaped cross section. A base portion 41 of the projection 36 is received through a slot provided in the channel 36 and an end portion 42 is received within the channel 36 to retain the cylindrical member 15.

[064] Figures 13 and 14 show a fifth embodiment of a paint container 10 in accordance with the present invention. The paint container 10 of Figures 13 and 14 is similar to the previous embodiments and like reference numerals are used to denote like parts. The first connectors 26 comprise projections 37 and the second connectors 27 include channels 36, however different configurations for the first and second connectors 26 and 27 are provided. The projections 37 are generally planar, however the channels 36 do not include the slots. Instead, the projections 37 include a recess 44 to be received over the edge of the channel 36. Also, outer surfaces of the channels 36 include tabs 46 provided to engage into corresponding slots 47 provided in the cylindrical member 15, to hold the cylindrical member 15 in place.

[065] In the embodiment of Figures 13 and 14, the upper end of the cylindrical member 15 also includes a lip 50 (as seen in Figure 13b). This lip 50 is provided to increase the likelihood that paint removed from a brush will flow into the cylindrical member 15.

[066] It will be readily apparent to persons skilled in the relevant arts that various modifications and improvements may be made to the foregoing embodiments, in addition to those already described, without departing from the basic inventive concepts of the present invention.

Claims

5

1. A paint container comprising:

a main body for receiving paint, the main body comprising a side wall and an outwardly tapering rim portion at an upper end of the side wall, the rim portion defining an opening into which paint can be poured;

10

a tubular member, a lower end of which is receivable within the rim portion;

first connectors provided on an outer surface of the tubular member; and

second connectors provided on an inner surface of the outwardly tapering rim portion;

15

wherein one of the first or second connectors comprises a protruding portion

including a vertical channel therein, wherein the protruding portion protrudes

into the opening defined by the rim portion and the other of the other of the first

or second connector comprises a projection extending vertically such that the

projections are received into ends of the channels as the tubular member is

moved downwardly into the rim portion such that the tubular member is

20

supported within the rim portion to define an annular aperture between the lower end of the tubular member and the main body of the paint container.

2. A paint container in accordance with claim 1, wherein the first connectors

engage with the second connectors by movement of the tubular member

towards the main body in a direction perpendicular to a central longitudinal axis

25

of the main body.

3. A paint container in accordance with claim 2, wherein the first connectors

each comprise the protruding portion including the vertical channel therein

being open at a lower end and the second connectors each comprise the

projections extending vertically upward such that the projections are received

30

into lower ends of the channels as the tubular member is moved downwardly into the rim portion.

4. A paint container in accordance with claim 3, wherein the projections include lugs on sides thereof adjacent the central longitudinal axis of the main body and the tubular member is provided with corresponding holes located within each of the channels such that the lugs engage into the holes to locate the tubular member relative to the main body.
5. A paint container in accordance with claim 2, wherein the second connectors each comprise the protruding portion including the vertical channel therein being open at an upper end and the second connectors each comprise the projections extending downward such that the projections are received into upper ends of the channels as the tubular member is moved downwardly into the rim portion.
6. A paint container in accordance with claim 5, wherein the projections extend downwardly from an associated cover portion, the cover portions comprising a planar member extending outwardly from the outer surface of the tubular member such that the cover member extends over the upper end of the channel.
7. A paint container in accordance with any one of the preceding claims, wherein the main body comprises a cylindrical vessel and the tubular member comprises a cylindrical member having a diameter such that the cylindrical member can be received in the opening defined by the rim portion.
8. A paint container in accordance with claim 7, wherein the rim portion tapers outwardly from adjacent a lower end thereof to the adjacent an upper end thereof to a greater degree than the taper of the cylindrical side wall.
9. A paint container in accordance with claim 8, wherein the cylindrical member is of the same diameter as that of the main body adjacent the rim portion.
10. A paint container in accordance with any one of the preceding claims, wherein an outer diameter of the main body adjacent the lower end is less than an inner diameter of the cylindrical member such that multiple paint containers may be placed in a stacked configuration.

5 11. A paint container in accordance with any one of claims 7 to 10, wherein the cylindrical member is received within the rim portion such that the lower end of the cylindrical member is located adjacent the lower end of the rim portion and an upper end of the cylindrical member is located above the upper end of the rim portion.

12. A paint container in accordance with any one of the preceding claims, wherein the first and second connectors are located at equal angular spacings around the tubular member and the rim portion.

10 13. A paint container in accordance with any one of the preceding claims wherein a handle is provided being connectable to the main body of the paint container and the rim portion is provided with securing members on outer sides thereof to engage with the handle such that the handle may be supported in one or more angular positions relative to the main body.

15 14. A paint container in accordance with claim 13, wherein the securing members include a pair of first protrusions located adjacent the upper edge of the rim portion above the connection between the handle and the rim portion such that the handle may be engaged between the first pair of protrusions to locate the handle in a vertical position.

20 15. A paint container in accordance with claim 14, wherein a pair of second protrusions is provided one on either side of the pair of first protrusions such that the handle engages with either of the second protrusions to hold the handle at an angle between vertical and horizontal.

2 / 14

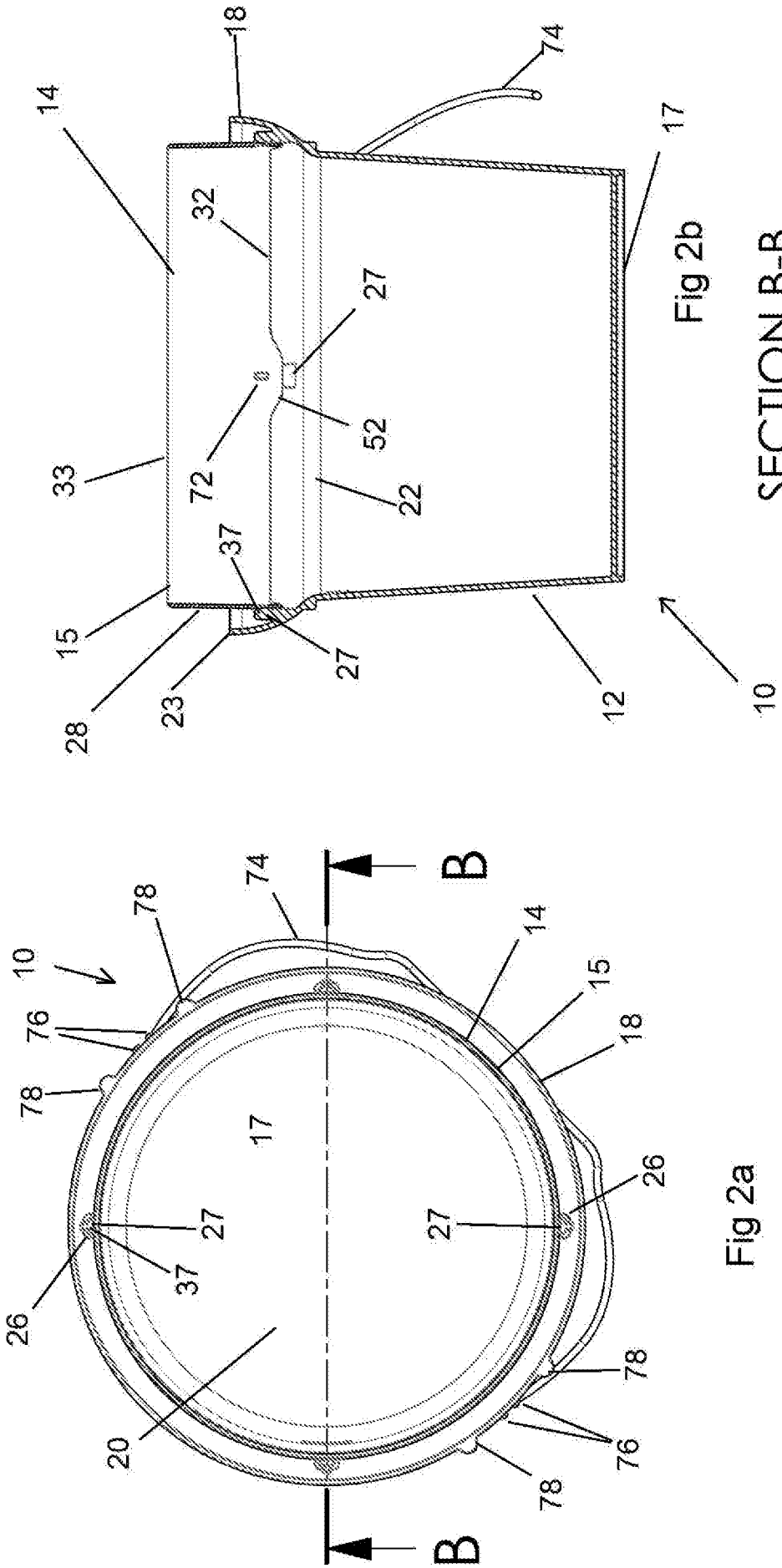
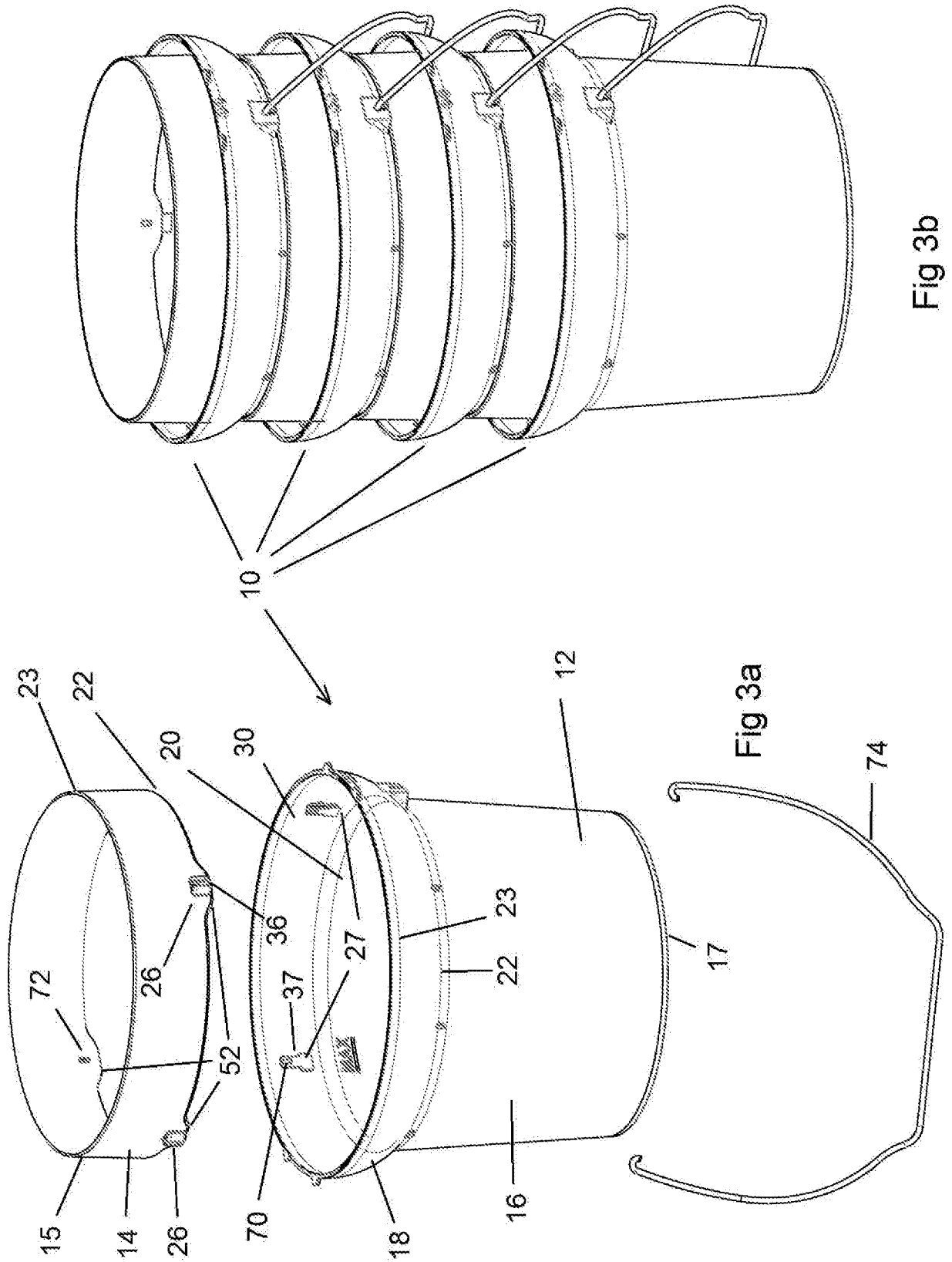

Fig 2b

SECTION B-B

Fig 2a



5 / 14

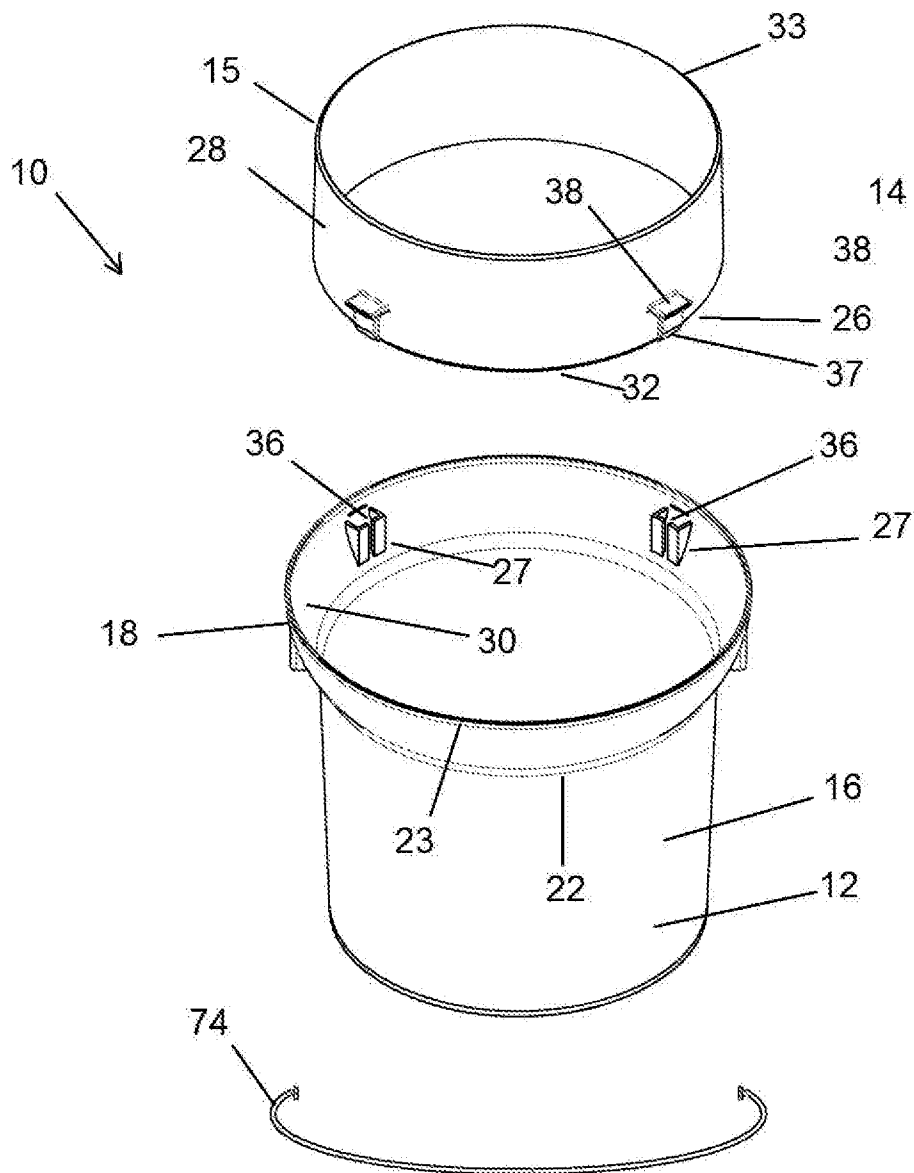

Fig 5

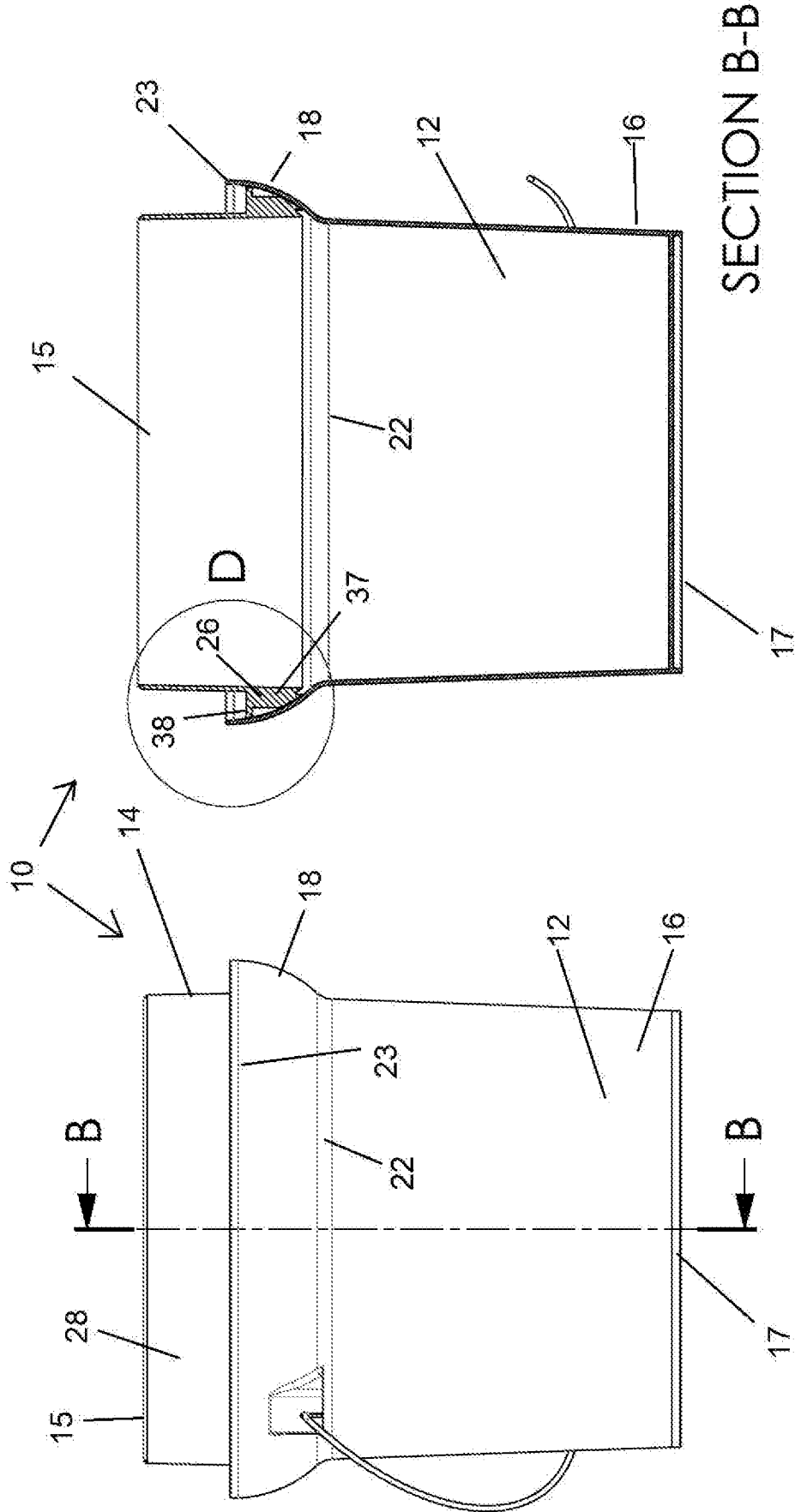
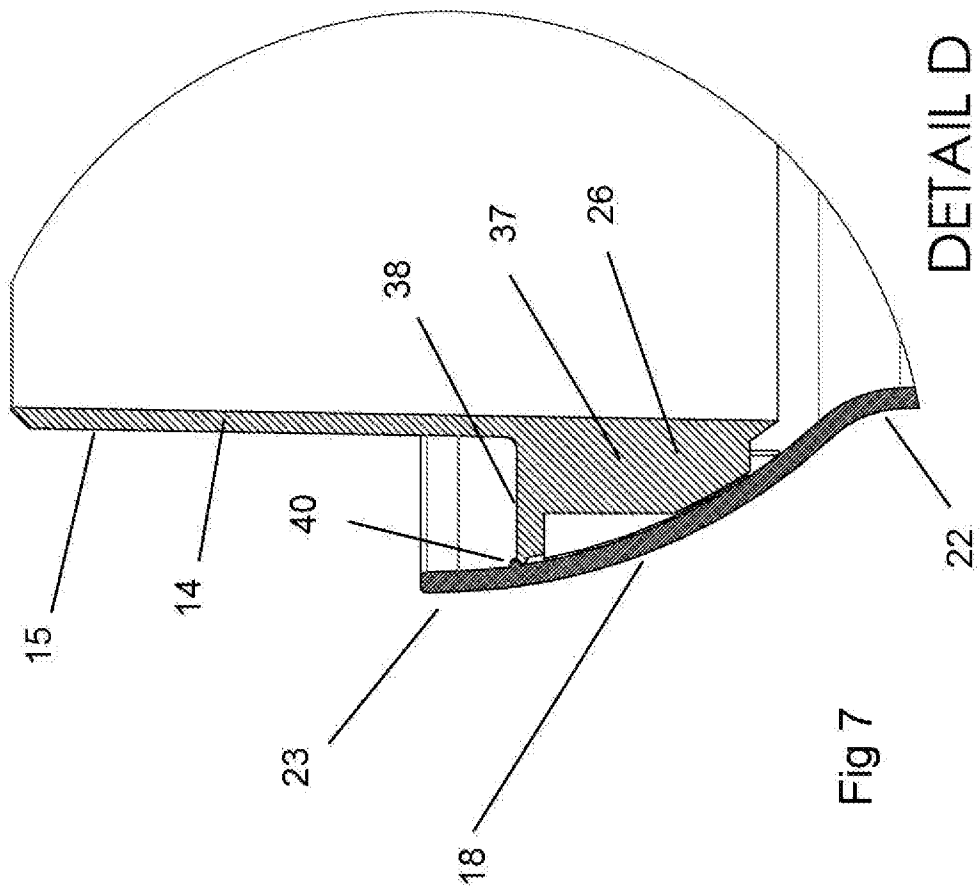

Fig 6b

Fig 6a



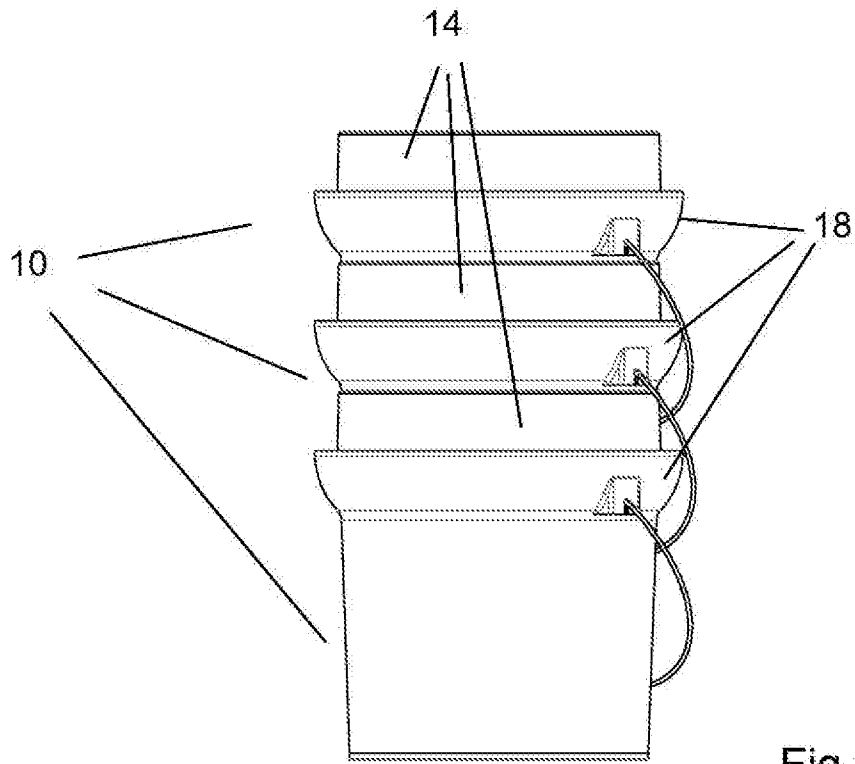

Fig 8

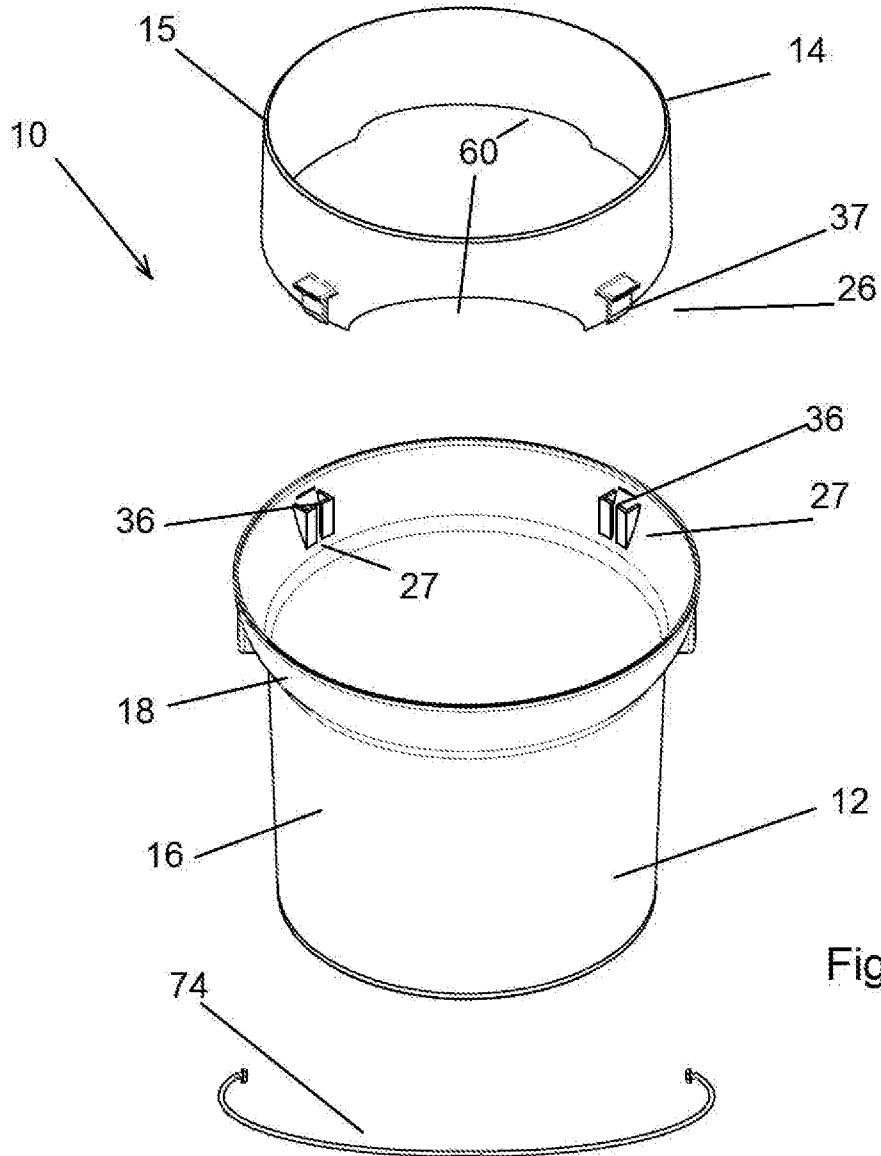

Fig 9

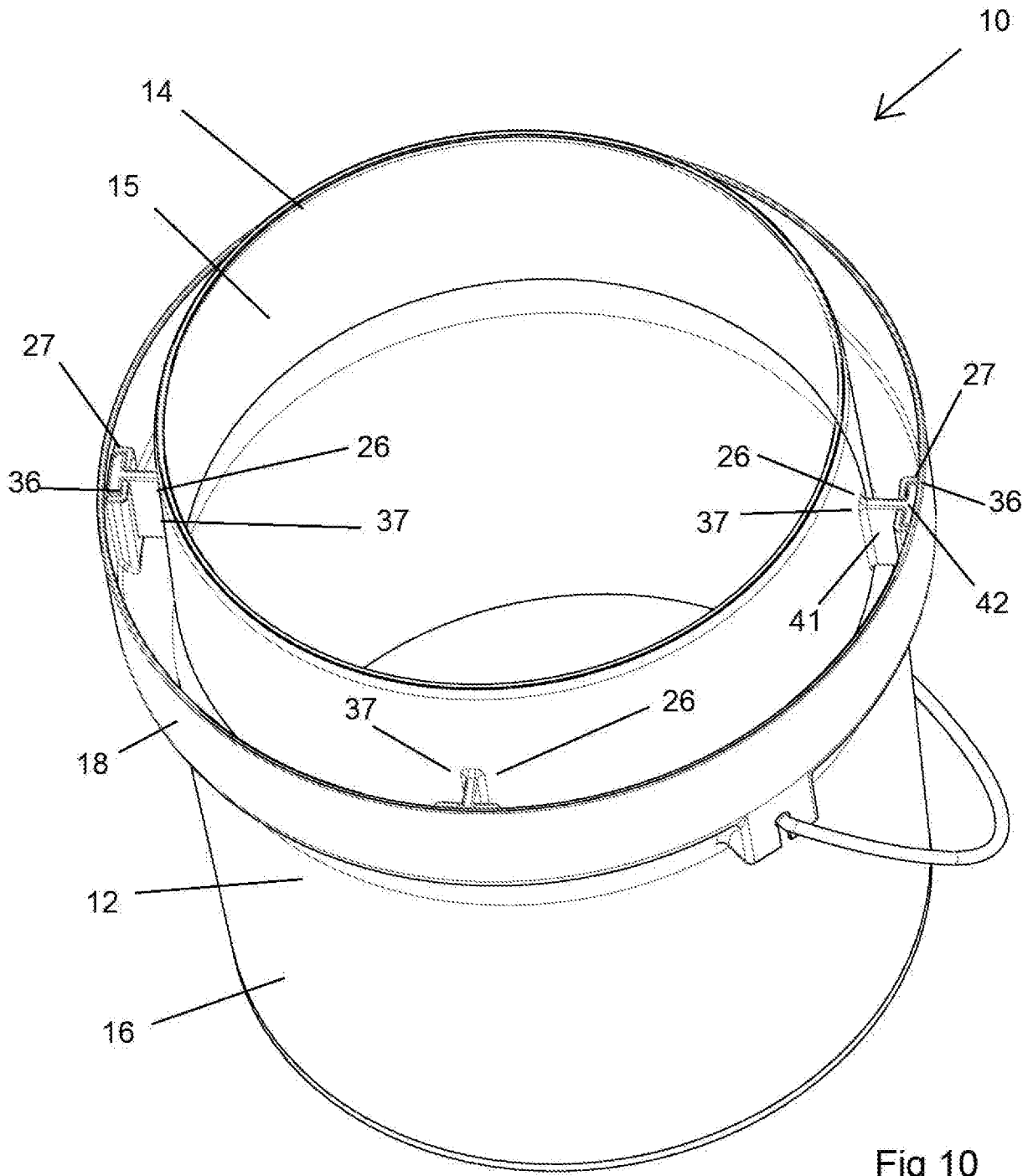

Fig 10

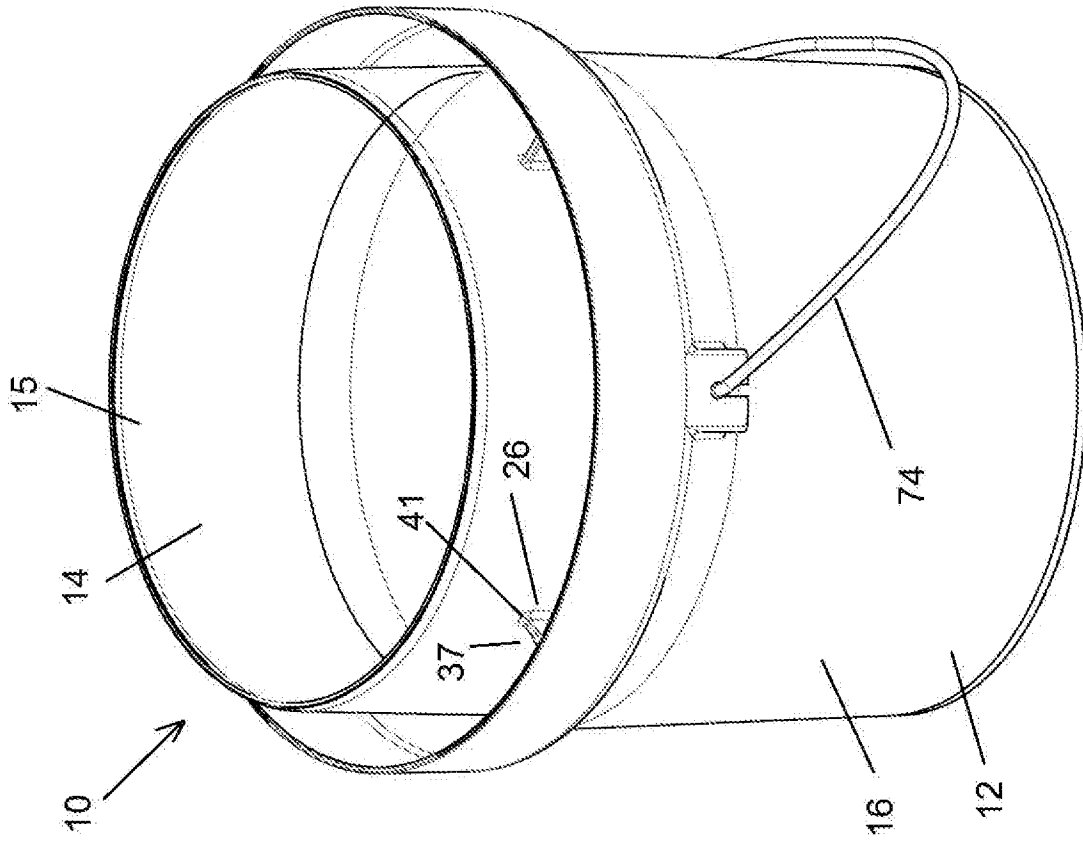

Fig 11b

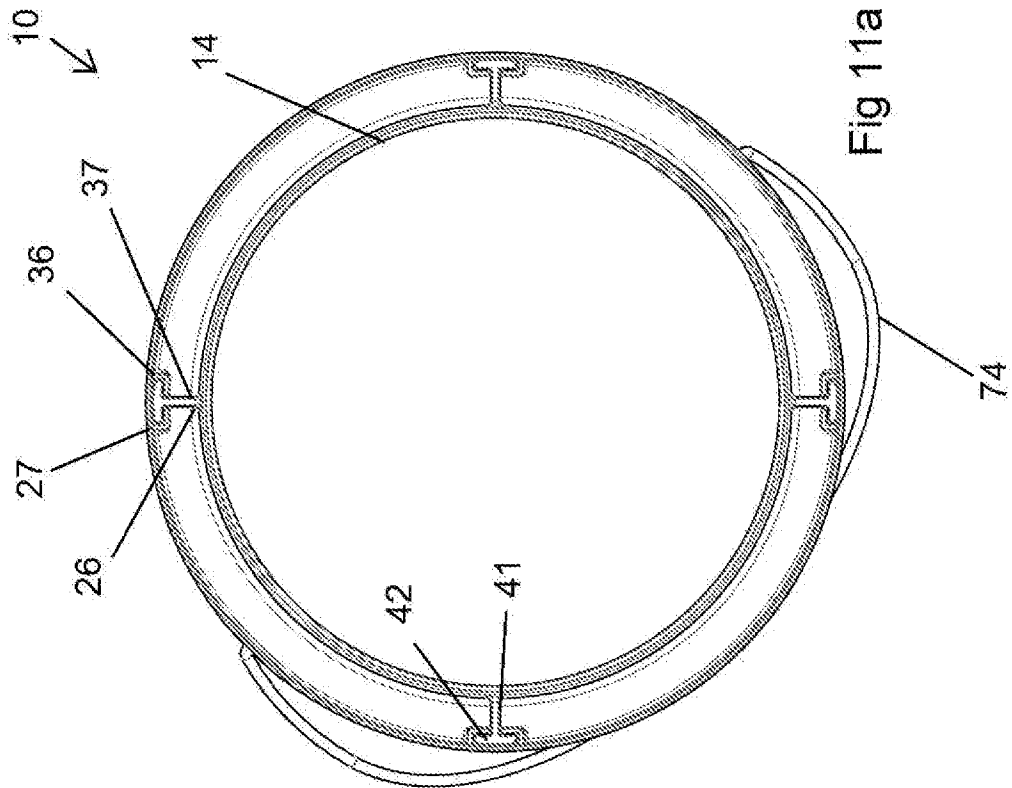

Fig 11a

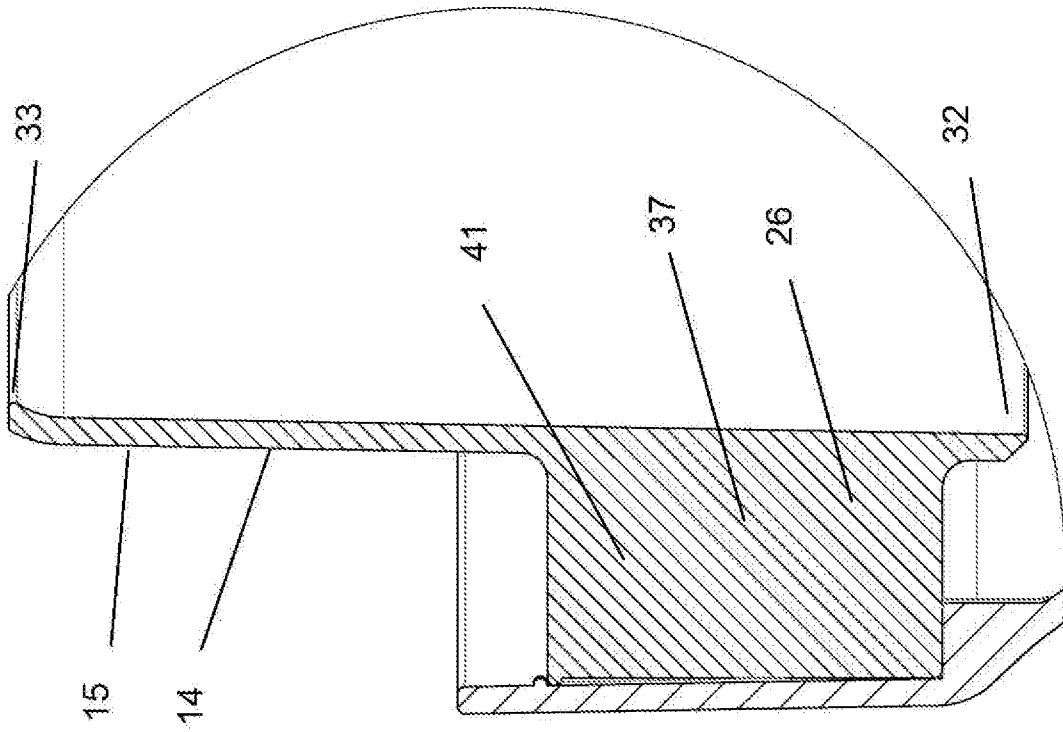

Fig 12b

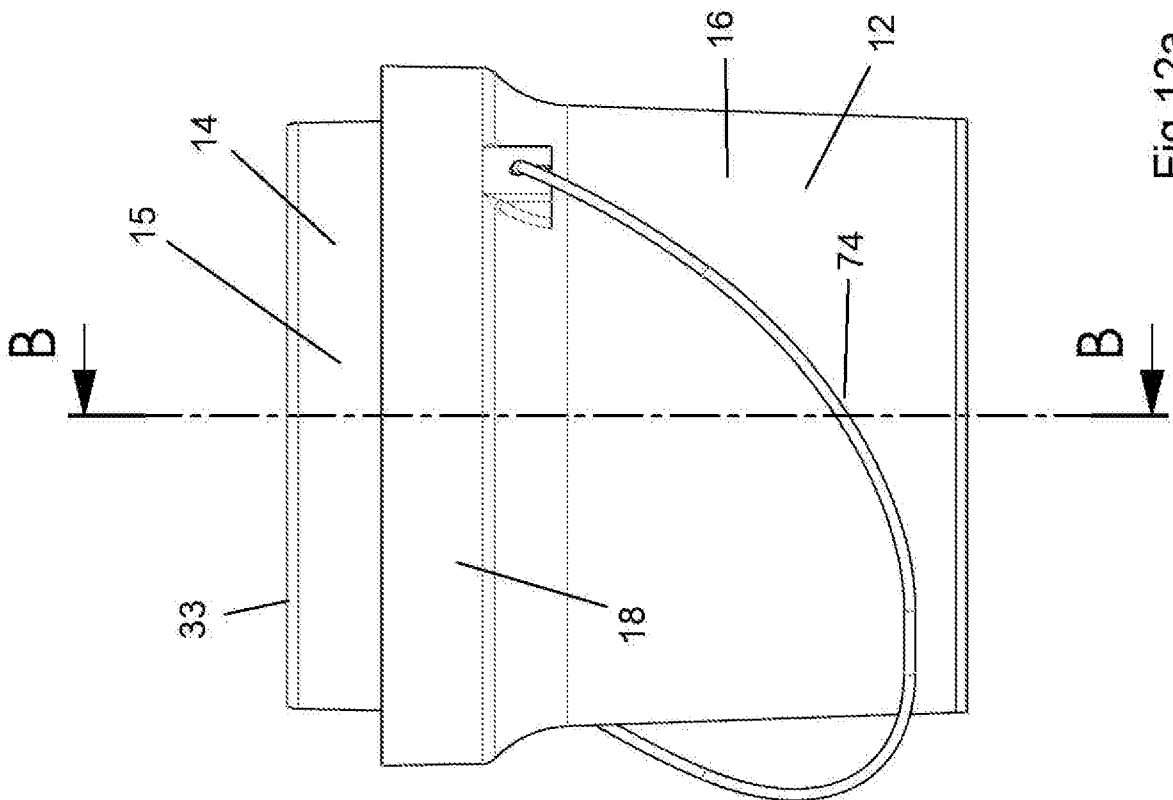

Fig 12a

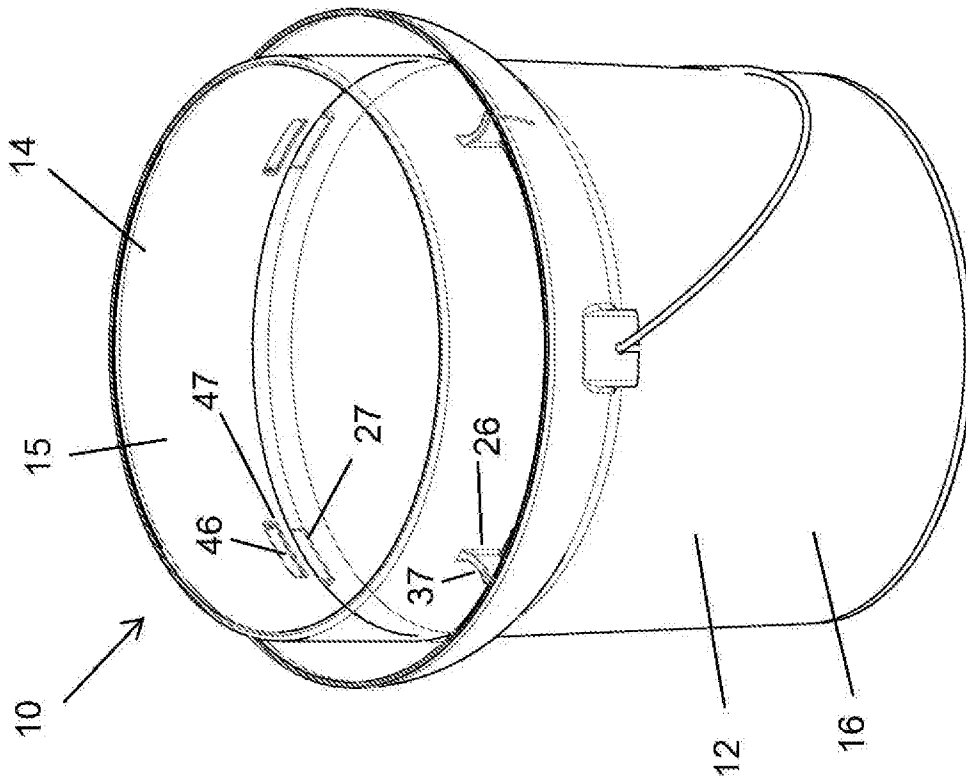

Fig 13b

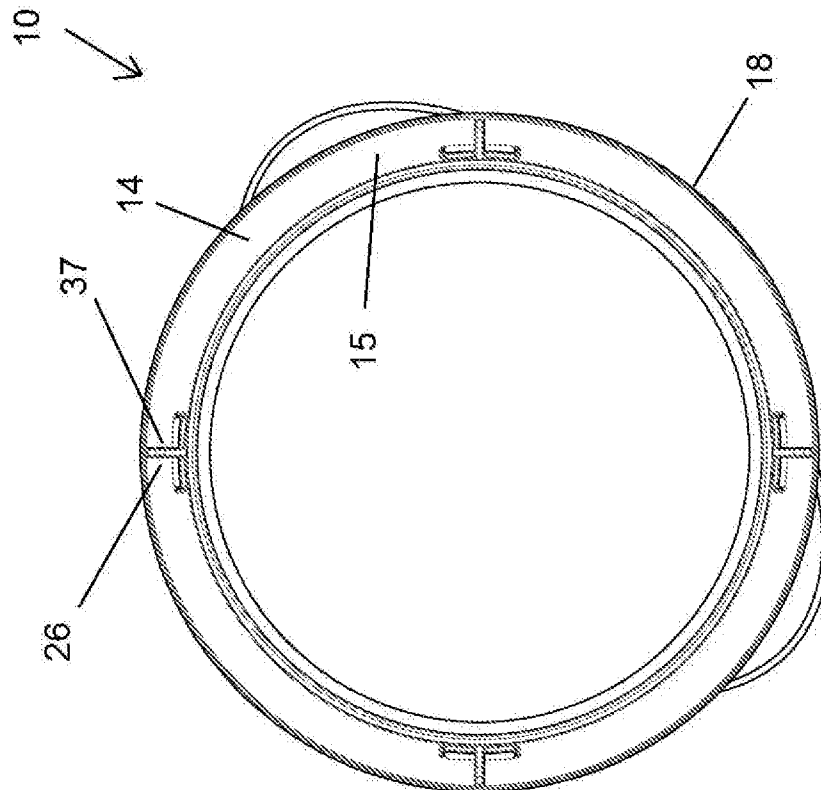

Fig 13a

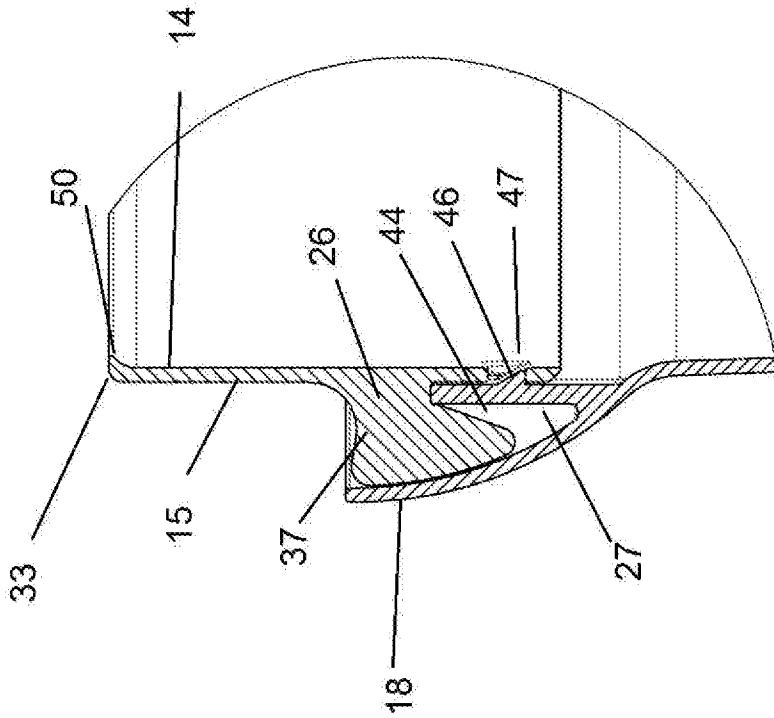

Fig 14b

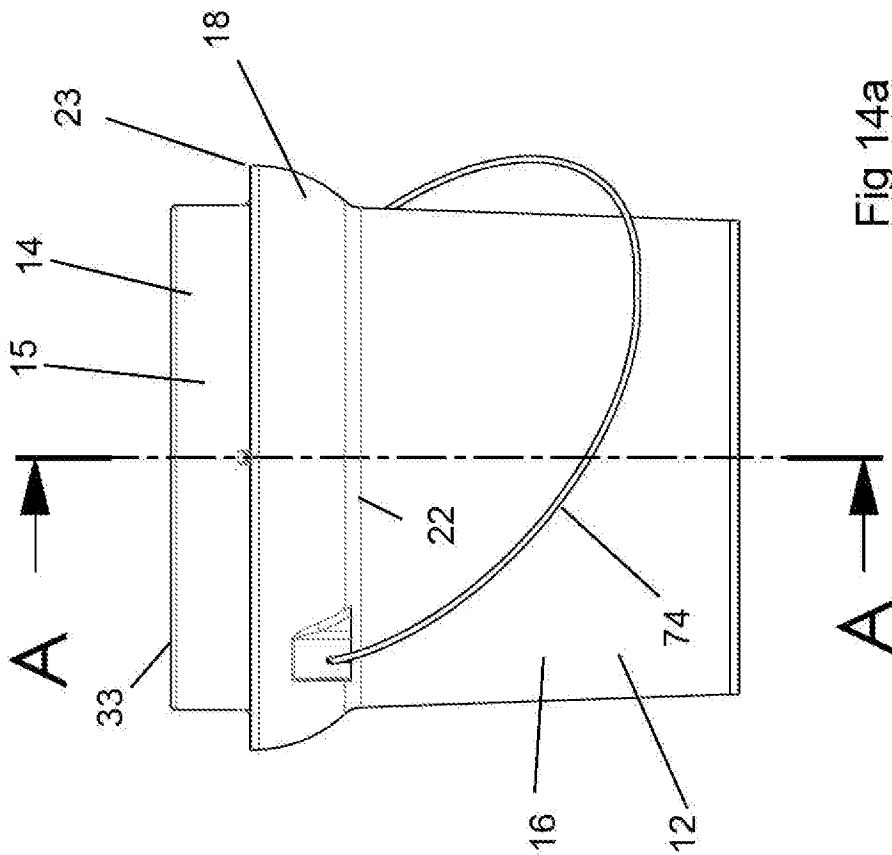

Fig 14a