

(19) World Intellectual Property
Organization
International Bureau



(43) International Publication Date
28 July 2005 (28.07.2005)

PCT

(10) International Publication Number
WO 2005/068288 A1

- (51) International Patent Classification⁷: **B64C 1/12**, B32B 3/12, B64C 1/40 (DE). **OESTEREICH, Wilko** [DE/DE]; Treschkowstr. 13, 28203 Bremen (DE). **REINELT, Thorsten** [DE/DE]; Tempelweg 4, 28816 Stuhr (DE).
- (21) International Application Number: PCT/EP2005/000040 (74) Agent: **KOPF, Korbinian**; Maiwald Patentanwalts GmbH, Elisenhof, Elisenstrasse 3, 80335 München (DE).
- (22) International Filing Date: 5 January 2005 (05.01.2005)
- (25) Filing Language: English (81) Designated States (unless otherwise indicated, for every kind of national protection available): AE, AG, AL, AM, AT, AU, AZ, BA, BB, BG, BR, BW, BY, BZ, CA, CH, CN, CO, CR, CU, CZ, DE, DK, DM, DZ, EC, EE, EG, ES, FI, GB, GD, GE, GH, GM, HR, HU, ID, IL, IN, IS, JP, KE, KG, KP, KR, KZ, LC, LK, LR, LS, LT, LU, LV, MA, MD, MG, MK, MN, MW, MX, MZ, NA, NI, NO, NZ, OM, PG, PH, PL, PT, RO, RU, SC, SD, SE, SG, SK, SL, SY, TJ, TM, TN, TR, TT, TZ, UA, UG, US, UZ, VC, VN, YU, ZA, ZM, ZW.
- (26) Publication Language: English (84) Designated States (unless otherwise indicated, for every kind of regional protection available): ARIPO (BW, GH, GM, KE, LS, MW, MZ, NA, SD, SL, SZ, TZ, UG, ZM, ZW).
- (30) Priority Data: 10 2004 001 080.3 5 January 2004 (05.01.2004) DE
- (71) Applicant (for all designated States except US): **AIRBUS DEUTSCHLAND GMBH** [DE/DE]; Kreetslag 10, 21129 Hamburg (DE).
- (72) Inventors; and (75) Inventors/Applicants (for US only): **MÜLLER, Rainer** [DE/DE]; Emsener Str. 16a, 21224 Rosengarten (DE). **TURANSKI, Peter** [DE/DE]; Kerchfeld 15, 27305 Süstedt

[Continued on next page]

(54) Title: PANEL ARRANGEMENT FOR AN INTERIOR LINING OF A PASSENGER CABIN IN AN AIRCRAFT

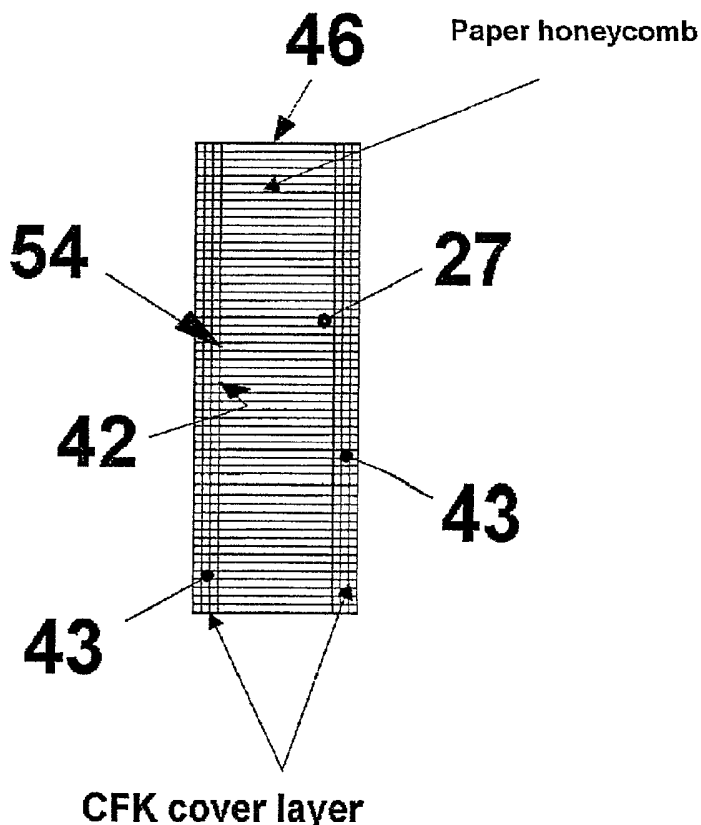

(57) Abstract: The invention relates to an arrangement for lining the interior of a passenger vehicle such as an airplane with several honeycomb panels (22) arranged side by side. Each honeycomb panel (22) comprises at least two fibre-reinforced plastic cover layer (44) glued respectively above and below at least one forming a laminate honeycomb core (46), which laminate is arranged so as to extend parallel to the outer skin of the aircraft and follow the curvature of the outer skin. The honeycomb formation used is made of paper- or aramide honeycomb cores or of a mixed combination of both honeycomb cores types. As an alternative, further fibre-reinforced plastic insulation layers are glued onto the outer surface of the respective cover layer (44) supported above and below the honeycomb formation. Moreover, the layer design of the honeycomb panelling may comprise further honeycomb cores which are additionally stacked on and glued to the honeycomb panel used.

WO 2005/068288 A1



ZW), Eurasian (AM, AZ, BY, KG, KZ, MD, RU, TJ, TM),
European (AT, BE, BG, CH, CY, CZ, DE, DK, EE, ES, FI,
FR, GB, GR, HU, IE, IS, IT, LT, LU, MC, NL, PL, PT, RO,
SE, SI, SK, TR), OAPI (BF, BJ, CF, CG, CI, CM, GA, GN,
GQ, GW, ML, MR, NE, SN, TD, TG).

For two-letter codes and other abbreviations, refer to the "Guidance Notes on Codes and Abbreviations" appearing at the beginning of each regular issue of the PCT Gazette.

Published:

— *with international search report*

FIELD OF THE INVENTION

5 The present invention relates to an interior panelling or interior trim of a vehicle. In particular, the present invention relates to an arrangement for an interior panelling, interior trim or lining of a cabin of an aircraft.

BACKGROUND OF THE INVENTION

10 From the field of aircraft engineering, largely combustible interior panelling is known with which the aircraft fuselage structure is lined near the outer skin of the fuselage. In this arrangement, in a space enclosed by the outer skin and the interior panelling, an insulation system may be installed which is arranged close to said outer skin, as shown in the enclosed Fig. 1.

15

The printed publication WO 00/75012 A1 discloses an aircraft fuselage insulation which is stated to be "fire-resistant". This printed publication discloses an insulation package which is arranged as primary insulation within a space situated between the interior panelling of the fuselage and the outer skin of the fuselage. In this arrangement that insulation package is protected in regions by a foil made of a fire-blocking material, wherein this foil region which acts in a fire-blocking way directly faces the outer skin of the fuselage (in the manner of a protective shield against fire). Furthermore, the printed publication proposes corresponding attachment elements for attaching the fuselage insulation, which elements mostly comprise plastic(s), for example a polyamide.

25

However, in relation to the application of such insulation systems (in aircraft), as far as the type of attachment and design of an insulation package used for insulating the fuselage, and as far as the interior panelling (inner panels), which is stated to be a fire-blocking material, are concerned, it is believed that no important improvements can be detected from the WO 00/75012 A1 with which, in a catastrophic fire, the spread of fire through the aircraft fuselage insulation and through the interior panelling of the aircraft would not only be retarded (impeded) but completely prevented.

35

- 2 -

SUMMARY OF THE INVENTION

According to an exemplary embodiment, an arrangement of an interior panel of an aircraft passenger cabin is provided, with which a space enclosed by the interior panelling and an outer skin of an aircraft is essentially filled.

Such arrangement may provide protection against unforeseen fire situations, in which arrangement the interior panelling may comprise honeycomb panelling made up of a honeycomb formation of several honeycombs arranged side by side.

A honeycomb body on the end of the cross section of the honeycomb body may be supported by and/or glued to a cover layer supported above and below the honeycomb formation such that by means of a top-supported cover layer facing the passenger cabin, and a bottom-supported cover layer facing a space, and a honeycomb body sandwiched between the two cover layers, a layer design of the honeycomb panelling is created, which layer design may be arranged so as to extend parallel to the outer skin and follow the curvature of the outer skin. This combination may comprise the following characteristics, according to which the honeycomb formation used may be made of paper- or aramide honeycombs or of a mixed combination of both honeycomb types, on whose cross section of the honeycomb body to both ends of the honeycomb bodies a CFK cover layer may be positioned, and/or further CFK insulation layers may be glued to the outer surface of the respective cover layer supported above and below the honeycomb formation.

The cover layer may comprise a CFK or GFK; and/or the layer design of the honeycomb panelling may comprise further honeycomb formations which may be additionally stacked on and glued to the honeycomb formation used.

It is believed that an exemplary embodiment of the present invention may provide for an improved arrangement for the interior panelling of a vehicle such as an aircraft, with which interior panelling the fuselage structure, which is situated in close proximity to the outer skin, is almost entirely lined, to such an extent that with it the flames of a seat of fire acting from outside the aircraft environment are largely prevented from entering the cabin space of the aircraft. The design of the interior

- 3 -

panelling and an insulation package attached to it are believed to be suitable for implementing an increase in the fire protection safety of separated interior regions that are situated near a structural outer skin.

- 5 The arrangement according to an exemplary embodiment is believed to prevent the spread of flames acting from outside the aircraft environment, of a source of fire, from penetrating the interior panelling, wherein the design of the interior panelling and the attachment of an insulation package to the interior panelling is implemented in such a way that the cabin region of the aircraft is protected against fire spreading
10 from outside the aircraft environment, and evacuation of the passengers from the vehicle is clearly facilitated.

It is believed that passenger cabins of an aircraft, for example of commercial plane of the type "Boeing" or "Airbus", may thus be constructed so that they are even better
15 protected against fire spreading from outside the aircraft surroundings, as can happen in a catastrophe in the case of an aircraft that has made an emergency landing or may withstand such fire for an extended time.

SHORT DESCRIPTION OF THE DRAWINGS

20 An exemplary embodiment of the invention is described in more detail with reference to the enclosed drawings. The following are shown:

Fig. 1 the arrangement of conventional interior panelling of a commercial
25 plane near the outer skin of the fuselage without showing the installed fuselage insulation;

Fig. 2 conventional fuselage insulation in a commercial plane;

Fig. 3 a (so-called) post-crash fire scenario relating to an aircraft that has
30 made an emergency landing;

Fig. 4 the conventional layer design of interior panelling (comprising a paper
honeycomb structure), which interior panelling (honeycomb
panelling) is not burn-through proof;

- 5 Fig. 5 the layer design of interior panelling (comprising a paper honeycomb structure), which interior panelling (honeycomb panelling) is believed to be burn-through proof or is believed to have improved burn-through characteristics;
- 10 Fig. 6 the layer design of interior panelling (comprising an aramide honeycomb structure), which interior panelling (honeycomb panelling) is believed to be burn-through proof or is believed to have improved burn-through characteristics;;
- 15 Fig. 7 a top view of a honeycomb formation, comprising paper honeycomb, of a layer design of Fig. 4;
- 20 Fig. 8 the layer design of Fig. 4 (modified by comprising a burn-through-proof enclosing foil);
- 25 Fig. 9 the layer design of Fig. 5, expanded by an additional layer design of the same type, of interior panelling (comprising a paper honeycomb structure), which interior panelling (honeycomb panelling) is believed to be burn-through proof or is believed to have improved burn-through characteristics;
- 30 Fig. 9a the layer design of Fig. 4 modified by comprising a burn-through-proof barrier layer;
- Fig. 9b the layer design of Fig. 5 (modified by comprising two burn-through-proof barrier layers; and
- Fig. 10 the layer design of burn-through-proof interior panelling (honeycomb panelling with a paper honeycomb structure) including a burn-through-proof insulation package attached to the interior panelling.

DETAILED DESCRIPTION OF EXEMPLARY EMBODIMENTS

A cabin panelling may be installed which encloses the aircraft cabin almost entirely. During a fire (e.g. a so-called "post-crash fire scenario"; e.g. Fig. 3), due to previous damage or burning-through (melting-through) of the metal outer skin, flames may act
5 on the interior panelling. Thus in the case of a fire associated with an aircraft that has made an emergency landing and is situated on the ground, (ignited) burning kerosene leaking from said aircraft may cause both the aluminium cell of the aircraft structure and the interior insulation to burn through or burn down. Respective burn-through tests on aircraft fuselage structures have shown that within a timeframe of ninety
10 seconds, both the aluminium outer skin (fuselage structure) of a passenger aircraft and the interior insulation (including the interior panelling) may burn through to such an extent that flashbacks into the interior of the passenger cabin may occur. These collected results show that evacuation of all injured and uninjured persons (passengers and aircrew) from the affected aircraft, or intervention by rescue teams
15 of the fire brigade and medical first aid may be simplified or improved if the vehicle's cabin is provided with an improved insulation system, cladding, lining or panelling.

There are insulation systems which essentially comprises a core material which is
20 embedded in an insulation package, wherein the insulation package is enclosed by a plastic foil.

A core- and insulation material that may be used comprises products of the fibre industry, of which products in particular glass fibre materials (glass wool) are in
25 widespread use. This material meets the requirements regarding thermal and acoustic insulation to a very large extent. In order to install (attach) the relatively amorphous semi-finished products to (or near) the aircraft fuselage structure, the insulation package (which is made from these semi-finished products) is enclosed in an enclosing foil. As far as the application of such insulation systems in aircraft
30 engineering is concerned, there are the following disadvantages: insulation systems, which comprise glass wool and single plastic foils are assumed to provide a burn-through time of less than sixty seconds which may be sufficient in some cases and which may be sufficient. In an assumed case of a fire, for example associated with an aircraft on the ground which has made an emergency landing, which case is shown in

the enclosed Fig. 2 (thus) the so-called post-crash fire scenario, burning kerosene may eventually may cause the aluminium cell of the aircraft structure and also the fuselage insulation (interior insulation) of the aircraft to burn through. There may be a desire to extend the burn trough time.

5

Also, it may be desirable that aircraft components are prevented from falling to the floor and endanger the intended evacuation during a fire incident.

10

Fig. 1 shows a cross section of part of a fuselage of a passenger aircraft. It shows the arrangement of interior panelling 20, which is primarily honeycomb panelling 22.

15

This arrangement, shows that the interior panelling 20 is arranged close to the outer skin 33 of the (inner) fuselage structure, which in the installed state together with the outer skin 33 encloses a space 19 within which the fuselage insulation (not shown in Fig. 1) is installed. The further components and elements of the interior outfit and the fuselage structure, which are shown in Fig. 1 and are integrated in an aircraft passenger cabin 21 (as shown in Fig. 1), are not shown for the sake of simplification.

20

The above-mentioned fuselage insulation is shown in Fig. 2.

25

Apart from meeting the actual insulation objectives, said insulation is also to provide protection in those fire situations which unexpectedly occur when an aircraft has made an emergency landing and is situated on the ground, wherein leaking kerosene unexpectedly ignites, wherein the flames of said fire will lick against the aluminium outer skin and thus against the fuselage insulation. Fig. 3 shows such a situation which will be described in detail below.

30

For greater ease of understanding Fig. 2, it should be mentioned by way of an introduction – due to the overview provided – that the structural unit of the aircraft fuselage not only comprises stringers 31 with which all the panels of an outer skin 33 of an aircraft (fuselage) structure 8 are stiffened, but also comprises several ribs 32 which are arranged perpendicular to the longitudinal axis 9 of the aircraft (approximately) at a distance c, and are attached to the stringer 31. Integrated in these ribs 32, on the unattached end is a (so-called) rib carrier 40 which continues on

- 7 -

parallel to the longitudinal axis 9 of the aircraft, wherein the (unattached free) end of the rib carrier 40 (according to this embodiment) is angled perpendicular to the longitudinal axis 9 of the aircraft.

5 Fig. 2 shows the position of an insulation package 3 (with general reference characters) (of the fuselage insulation) on the (near) outer skin 33 of the aircraft. In each instance this insulation package 3 conventionally comprises a field insulation package 17 and a rib insulation package 16, which in the way are both installed separately and are attached near the outer skin 33 or are attached so as to rest against
10 a stringer support surface 31a of the stringer 31 (i.e. in a defined structural zone of the aircraft fuselage structure).

Fig. 2 thus shows that a field insulation package 17 has been placed between the (two) ribs 32, spaced apart at a distance c , near (resting against) an inner area of a panel of the outer skin of the outer skin 33. Furthermore, a rib insulation package 16
15 has been placed onto the rib carrier 40, wherein said rib insulation package 16 is guided so as to be resting on both sides against the longitudinal sides 41 of the ribs. When viewed from the side as shown in Fig. 3, the rib insulation package 16 is guided not only on the so-called front longitudinal side 41 (the right-hand side) of the
20 rib but also on the so-called rear longitudinal side 41 (the left-hand side) of the rib.

These two insulation packages are completely enclosed by a combustible plastic foil. They are arranged within that space 19 (shown in Fig. 1) which is constituted by the (traditionally installed) interior panelling 20 of the aircraft and the panelling of the
25 outer skin 33.

In order to illustrate the situations focused at and believed to be improved in accordance with the present invention, and to further explain an increase in fire protection safety by partitioning off spaces, which spaces include a space 19 enclosed by the outer skin 33 and by interior panelling 19 of the aircraft cabin 21, said space 19 being arranged parallel at a defined distance (transversely to the longitudinal axis of the fuselage 9), (with reference to Fig. 3) a "fire situation" involving an aircraft after an emergency landing will be described in the following which is believed to allow a better understanding of the measures and features of the

present invention. If, in the context of such a (hypothetical) fire situation, referred to as a "post-crash fire scenario" 7, one considers that an emergency situation for passengers and the aircrew will result in a fire in the fuselage, i.e. in the interior of the cabin in the case of an aircraft structure 8 (damaged from the outside) (with a defective outer skin 33) following external mechanical action and a resulting fire acting on the shown aircraft regions due to spillage and ignition of kerosene, then it becomes clear that fire-protection measures have to be provided if the (possibly injured) passengers and flight crew are all as quickly as possible to be evacuated from the passenger area or cabin area to the outside of the aircraft by way of the emergency slide, i.e. within sufficient time.

Below, respective improvements and exemplary embodiments of the present invention are described with reference to Figures 5 to 10.

In order to provide better fire protection safety for separated interior space regions (cabin regions), for example of a passenger aircraft, which interior space regions are situated near the outer skin 33 of the aircraft fuselage, it should be mentioned at this point, in anticipation of Fig. 10, that with a burn-through-proof foil 11 made of a fireproof foil material (as disclosed therein) it is certainly possible to provide effective preventative fire protection to the interior panelling 20, in this case to the interior of an aircraft passenger-cabin 21, against any fire occurring.

This foil 11 will completely enclose a so-called insulation package 55 (fuselage insulation package), which for example results from the integration of a field insulation package 17 and a rib insulation package 18, which (in a way different to the situation in Fig. 2) are now combined as a package, which insulation package 55 is used for insulating the interior of a fuselage in line with the hitherto applied installation technology (installed so as to be supported by the stringer and resting against the ribs and installed near the outer skin 33). Advantageously, the paper honeycomb architecture of the insulation package 55 (fuselage insulation package), from a burn-through-proof barrier layer 58, will extend within the package cross section (the cross section of the insulation) right up to the foil margins, which barrier layer should comprise a material which is highly fireproof, with said material being

sufficiently resistant and/or insensitive to any fire that might occur, and which barrier layer extends without interruption along the stretched length of the package.

As an alternative it would be imaginable that instead of the paper honeycomb 27 of the fuselage insulation package (as shown in Fig. 10) aramide honeycombs 28 (Nomex honeycombs) be used, in which case the arrangement of said barrier layer 58 would not be necessary. The foil enclosure with the proposed burn-through-proof foil 11, which may comprise a flame-rejecting foil material of considerable and long-lasting fireproofness which is resistant and/or insensitive to fire and which prevents any burning-through of the foil wall as a result of the influence of the flaming fire even during prolonged action on the surface area of the foil and prevents the flames licking towards the foil wall area, with the use of aramide honeycombs or some other suitable burn-through-proof honeycomb material as an insulation core material will not always provide the benchmark for expedient implementation of preventative fire protection on the insulation packet 55 (fuselage insulation packet), it will however make a considerable contribution to provide such fire protection.

In addition, said insulation package 55 may comprise a hole-like leadthrough 60 which is congruent with a threaded drill hole 59 drilled in a cover layer 30b (as shown in Figures 5 to 10) arranged in the insulation core material, provided the insulation package 55 is arranged on the bottom-supported outer surface of this cover layer 30b or is aligned with a CFK-insulation layer 45 (possibly supported by said cover layer 30b. The insulation package 55 is attached with a burn-through-proof connection element 61, which for example comprises a plastic of poor thermal conductivity of sufficient strength, or at least comprises such an enclosure, to said bottom-supported GFK cover layer 30b, which connection element 61 is fed through the hole-like leadthrough 60 and can be screwed into the threaded drill hole 59. With this connection element, the presented insulation package 55 will be attached to the interior panelling 20 or to the honeycomb panelling 22 of the interior panelling 20, which will be discussed in detail below.

By providing the proposed foil material of the fuselage insulation package 19 on its own, it will not be possible (it is believed to not be possible) to counter the impending hazards in a (non-foreseeable and non-desired) case of a catastrophic fire

involving an aircraft – for whatever reasons – in order to ward off the threatening hazards of a catastrophic fire. At least one cannot depend on this measure alone if one wishes to implement comprehensive preventative fire protection in the cabin region of an aircraft passenger cabin 21.

5

For this reason, the above-mentioned average person skilled in the art, who knows the state of the art as mentioned in the introduction, thanks to his/her creativity will seek further solutions in order to improve the interior space panelling from the point of view of fire protection.

10

Below, respective solutions (exemplary embodiments) for creating burn-through-proof interior space panels 20 as shown in Figures 5 to (9a and) 9b are proposed to said average person skilled in the art, which solutions, apart from the foil package 55 (attached to the honeycomb panelling 22), said person, since (during a simulated emergency) s/he cannot and will not solely depend on the burn-through-proof foil package 55, will want to principally incorporate into his/her further considerations for implementing preventative fire protection.

15

Fig. 4 shows a (so-called first) honeycomb formation 46 which may be used in the production of honeycomb panels 22 for aircraft construction. The honeycomb formation 46 integrates several paper honeycombs 27, arranged side by side, which (as shown in Fig. 7) are attached (glued) to each other along the circumference. The design of those honeycomb panels 22 is supplemented by (at least) two cover layers 30a, 30b, wherein in each instance one cover layer 30a or 30b is placed onto the cross section of the honeycomb body 27 (made of paper) and onto both ends of the bodies of the honeycombs, and at the location (shown by an arrow) of a point of adhesive bond 54 is attached to the honeycomb body 27. These cover layers 30a, 30b may comprise a combustible GFK material which while satisfying the hitherto specified parameters (strength, noise reduction etc.) has neither fire-blocking nor burn-through-proof qualities. Therefore, honeycomb panelling comprising panel-shaped GFK cover layers 44 and a honeycomb formation 46 of several honeycomb bodies 27 will provide for a fire protection which, however, may be further improved as will be described in the following.

20

25

30

In contrast to the above, honeycomb panelling 22 which has been implemented as shown in Fig. 5 will provide for further improved fire protection parameters. If the GFK cover layers 44 used in the construction of honeycomb panelling 22 according to Fig. 4 are replaced by CFK cover layers 43, one arrives at the proposed solution according to Fig. 5. This solution takes into account that a CFK cover layer 43 (in the same way as the honeycomb formation 48 made of paper honeycombs 27) on both sides of the honeycomb body 23 at the end 42 of the honeycomb body rests against the cross section 29 of the honeycomb body and is glued onto the paper honeycombs 27.

10

As an alternative, honeycomb panelling 22 is proposed which takes into account the exchange of the (first) honeycomb formation 46, integrated from several paper honeycombs 27, as shown in Fig. 4, by a honeycomb formation 46a, integrated from aramide honeycombs 28, as shown in Fig. 6.

15

Honeycomb panelling 22 designed in such a way will also be expedient for implementing preventative fire protection.

Fig. 7 shows the (previously mentioned) honeycomb formation 46 of the honeycomb panelling 22 shown in Fig. 4. This top view clearly shows the honeycomb bodies 23 of a honeycomb body arrangement implemented with the use of paper honeycombs 27. Also shown are the honeycomb body cross section 29 of said arrangement, which cross section is for example hexagonal, and the end 42 of the honeycomb body of the individual paper honeycomb 27. To achieve a further increase in the burn-through-proofness of this honeycomb panelling 22, it is imaginable that instead of the paper honeycombs 27 shown, corresponding aramide honeycombs 28 are used.

The solution according to Fig. 8 also uses honeycomb panelling 22 as shown in Fig. 4 and in addition a foil 11 which is arranged so as to rest flat against the outer surface of a GFK cover layer 44. This foil 11 comprises a fireproof foil material which renders the foil 11 essentially burn-through proof. This foil 11 is glued onto said outer surface by means of a fireproof adhesive. This provided honeycomb panelling 22 too will meet the requirements for implementing effective preventative fire protection in aircraft construction.

30

An arrangement as shown in Fig. 9 efficiently implements the ability of honeycomb panelling 22 which might become exposed to the flames of a fire for an extended period of time to not only hinder burn-through of the panel body, wherein the latter
5 in the most unfavourable case finally (depending on the intensity of the effect of the flames) after a corresponding period of time will nevertheless burn through, but instead will display a burn-through-proof behaviour which will (to the furthest extent possible) entirely preclude flashback through the panel body, provided the installation of said panel body has been carried out in an expert manner.

10

Although the production of this burn-through-proof honeycomb panelling 20 will involve greater expenditure (concerning the use of materials and labour), the desired advantages for the intended purpose and use will outweigh this. This burn-through-proof honeycomb panelling 22 (interior panelling 20) is implemented with a first
15 arrangement 50 which corresponds to the layer structure as shown in Fig. 5; and a second arrangement 51 with an identical layer structure (as shown in Fig. 5).

Accordingly, it is proposed that the first arrangement 50 be arranged with a top-supported and bottom-supported CFK cover layer 43, each resting above and below
20 the honeycomb formation 46 (which comprises paper honeycombs 27), while the second arrangement 51 which has the same layer design is arranged in a laminar way, adjacent to the former, whose adjacent CFK cover layers 43 which are a top-supported cover layer 30a (CFK cover layer 43) of the first arrangement 50, and a bottom-supported cover layer 30b (CFK cover layer 43) of the second arrangement
25 51 or vice versa, are glued together.

Other arrangements (not shown in the Figures) comprising the same layer design (as shown in Fig. 5), which are arranged in a laminar way and adjacent to each other in series, up to a final nth arrangement, are also imaginable (depending on the desired
30 thickness of the integrated honeycomb panelling 22 (interior panelling 20), wherein the cover layers 30a, 30b, which are adjacent to each other and lying one on top of the other, are glued. In this arrangement, the top-supported or bottom-supported cover layer 30a, 30b of the second arrangement 51, is glued on from the cover layer 30a, 30b of the serially following arrangement. To further improve the burn-through

proofness of that proposed honeycomb panelling construction (those proposed honeycomb panel constructions) as shown in Figure 9, it is proposed that instead of honeycomb formations 46 made with the use of paper honeycombs 27, honeycomb formations with aramide honeycombs 28 (Nomex honeycombs) be used instead and the thickness of the respective honeycomb formation 46 [the honeycomb length of the honeycomb bodies 23] (shown in correlation in Fig. 7) and/or that the thickness of the CFK cover layers 43 be varied.

A further option of increasing burn-through proofness is provided with the modification of a layer arrangement as shown in Fig. 5, whose honeycomb panel construction is implemented as shown in Fig. 9b with four honeycomb formations 46, 47, 48, 62 which are arranged in a laminar way side by side, whose adjacent ends 42 of the honeycomb body face each other.

Fig. 9a also shows such honeycomb panelling 22 which comprises two honeycomb formations 46, 47 with paper honeycombs 27. This arrangement comprises two honeycomb formations 46, 47 sandwiched between a burn-through-proof barrier layer 58. The barrier layer 58 comprises a material of a high fireproofness, which material is adequately resistant to and/or insensitive to fire. In this arrangement, this barrier layer is positioned adjacent to the body ends of the paper honeycombs 27, sandwiched between a first and a second honeycomb formation 46, 47, where it is immovably glued into place with a (previously mentioned) adhesive. The GFK cover layers 44 which adjoin the other side of the ends of the bodies of the paper honeycombs 27 too are glued on with the same adhesive.

Returning to the arrangement according to Fig. 9b it should also be added that those four honeycomb formations 46, 47, 48, 62 which comprise paper honeycombs 27 also comprise a barrier layer 49, 52, 53, as shown in Fig. 9, sandwiched between the adjacent honeycomb formations 46, 47 or 47, 48 or 48, 62. These barrier layers 49, 52, 53 are also attached in the way shown in Fig. 9a. In addition, a CFK cover layer 43 is positioned against the outer honeycomb formations 46 and 62 adjacent to the (hitherto) un-glued ends of the honeycomb bodies of the paper honeycombs 27, with said CFK cover layer being attached to the paper honeycombs 27 by gluing.

Accordingly, (as shown in Fig. 9b) the construction of the honeycomb panelling 22, apart from the first (used) CFK barrier layer 49, is additionally supplemented by a second CFK barrier layer 52 as well as by a third CFK barrier layer 53, wherein the stated outer honeycomb formations 46, 62 are facing towards the inner surface
5 (pointed in the direction of the respective end of the paper honeycomb body) of the respective cover layer 30a, 30b and towards the paper honeycombs 27, supported and glued to the latter.

In this arrangement the first and second CFK barrier layer 49, 52 and the third CFK
10 barrier layer 53 are a thick or thin CFK barrier layer. If possible at least one of the three CFK cover layers 49, 52, 53 is thin, wherein the thin CFK barrier layers 49, 52, 53 are made from a burn-through-proof plastic foil. With a view to improving the desired burn-through-proofness of this honeycomb panelling 22, at least one thick CFK barrier layer 53 should be arranged close to the CFK cover layers 43, wherein
15 during installation of the honeycomb panelling it must be ensured that this CFK barrier layer 62 is installed closer to the outer skin 33 (than are the two other CFK barrier layers 49, 52).

Returning to the first explained solution shown in Fig. 10, it should be added that this
20 solution uses honeycomb panelling 22 as shown in Fig. 4, at whose bottom-supported cover layer 30b, which faces the space 19 and thus the outer skin 33 of the aircraft, panel-shaped insulation 56 is arranged, which comprises a burn-through-proof material, for example a CFK material, and is positioned so as to rest flat against said cover layer 30b. Said elongated insulation package 55, which is
25 completely enclosed by the burn-through-proof foil 11, is adjacent to this insulation 56. The bottom-supported GFK cover layer 30b, and if applicable also a burn-through-proof CFK insulation layer (not shown in the Figures), which CFK insulation layer is sandwiched in addition to the insulation 56 and the foil 11 and which is glued to the insulation 56 or to the outer foil surface of the foil 11,
30 comprises/comprise a threaded drill hole 59 which extends perpendicular to the surface of this GFK cover layer 30b. Furthermore, the insulation package 55 comprises a hole-like leadthrough 60 which is congruent to the threaded drill hole 59, provided the insulation package 55 is arranged on the outer surface of the

- 15 -

bottom-supported GFK cover layer 30b, or the burn-through-proof CFK insulation layer 45.

By means of a burn-through-proof connection element 61, the insulation package 55
5 is attached to said bottom-supported GFK cover layer 30b, with said connection element 61 being inserted through the hole-like leadthrough 60 and being screwably attached by rotation in the threaded drill hole 59.

It should be noted that the application of the present invention is not limited to the
10 aircraft industry. The fire insulation systems described above may also be implemented in any vehicles such as cars or busses, but also for any rooms or spaces requiring such protection.

REFERENCE CHARACTERS

	1	Insulation material
	2	Enclosing foil
5	3	Insulation package
	4	First attachment element; insulation pin
	7	Post-crash fire scenario; fire
	8	Aircraft structure
	9	Longitudinal axis of the aircraft
10	11	Burn-through-proof foil
	12	
	13	Second attachment element, truncated-cone body
	15	
	17	Field insulation package
15	18	Rib insulation package
	19	Space
	20	Interior panelling
	21	Aircraft passenger cabin
	22	Honeycomb panelling
20	23	Honeycomb body
	24	Through hole; drill hole
	25	First honeycomb panel
	26	Second honeycomb panel
	27	Paper honeycomb
25	28	Aramide honeycomb (Nomex honeycomb)
	29	Cross section of the honeycomb body
	30	Cover layer
	30a	Cover layer, top supported (facing the passenger cabin 21)
	30b	Cover layer, bottom supported (facing the outer skin 33)
30	31	Stringer
	31a	Stringer support area
	32	Rib
	32a	First rib
	32b	Second rib

	33	Outer skin
	33a	Inner area (of a panel of the outer skin 33)
	40	Rib carrier
	40a	End (of the rib carrier 40)
5	41	Longitudinal side of the rib
	42	End of the honeycomb body
	43	CFK cover layer
	44	GFK cover layer
	45	CFK insulation layer
10	46	First honeycomb formation – with paper honeycombs 27
	46a	Honeycomb formation – with aramide honeycombs 28
	47	Second honeycomb formation
	48	Third honeycomb formation
	49	First CFK barrier layer
15	50	First arrangement
	51	Second arrangement
	52	Second CFK barrier layer
	53	Third CFK barrier layer
	54	Point of adhesive bond
20	55	Insulation package
	56	Burn-through-proof insulation
	57	Non-burn-through-proof insulation
	58	Barrier layer, burn-through-proof
	59	Threaded drill hole
25	60	Leadthrough, hole-like
	61	Connection element, burn-through-proof
	62	Fourth honeycomb formation
	c	Spacing (between the ribs 32a, 32b)

CLAIMS

1. Arrangement of an interior panel of an aircraft passenger cabin, with which a space (19) enclosed by the interior panelling (20) and an outer skin (33) of an aircraft is filled; which arrangement will provide protection against unforeseen fire situations; in which arrangement the interior panelling (20) comprises honeycomb panelling (22) made up of a honeycomb formation (46) of several honeycombs (27, 28) arranged side by side, whose honeycomb body (23) on the end of the cross section (29) of the honeycomb body is supported by and glued to a cover layer (30) supported above and below the honeycomb formation (46) such that by means of a top-supported cover layer (30a) facing the passenger cabin (21), and a bottom-supported cover layer (30b) facing a space (19), and a honeycomb body (23) sandwiched between the two cover layers (30a, 30b) a layer design of the honeycomb panelling (22) is created, which layer design is arranged so as to extend parallel to the outer skin (33) and follow the curvature of the outer skin (33), wherein the combination comprises the following characteristics, according to which the honeycomb formation (46) used is made of paper- or aramide honeycombs (27, 28) or of a mixed combination of both honeycomb types; on whose cross section (29) of the honeycomb body to both ends (42) of the honeycomb bodies a CFK cover layer (43) is positioned; and/or further CFK insulation layers (45) are glued to the outer surface of the respective cover layer (30a, 30b) supported above and below the honeycomb formation (46), which cover layer (30a, 30b) comprises a CFK or GFK; and/or the layer design of the honeycomb panelling (22) comprises further honeycomb formations (47) which are additionally stacked on and glued to the honeycomb formation (46) used.
2. The arrangement of claim 1, wherein a burn-through-proof barrier layer (49) is sandwiched between a honeycomb formation (46) comprising paper honeycombs (27) and a further stacked honeycomb formation (47) which is made from paper honeycombs (27), as well as being sandwiched between further stacked honeycomb formations (48) which are made of paper

honeycomb (27), wherein said burn-through-proof barrier layer (49) is glued onto the adjacent honeycomb formations (46 to 48).

3. The arrangement of claims 1 and 2, wherein a cover layer (30a, 30b) comprising GFK is positioned on the cross section (29) of the honeycomb body of a honeycomb formation (46 to 48) comprising paper honeycombs (27), on both ends (42) of the honeycomb body, wherein said cover layer (30a, 30b) is enclosed by a burn-through-proof foil (11).
4. The arrangement of claim 1, wherein a first arrangement (50) of interior panelling (20) with a CFK cover layer (43) each resting above and below the honeycomb formation (46) used, and a second arrangement (51) of identical design arranged in a laminar way, are adjacent to each other, wherein their adjacent CFK cover layers (43), which are a top-supported cover layer (30a) of the first arrangement (50); and a bottom-supported cover layer (30b) of the second arrangement (51) or vice versa, are glued together.
5. The arrangement of claim 4, wherein further arrangements of the same type, up to a final nth arrangement, are arranged in a laminar way and adjacent to each other in series, wherein the cover layers (30a, 30b) which are adjacent to each other and lying one on top of the other, are glued, wherein the top-supported or bottom-supported cover layer (30a, 30b) of the second arrangement 51 is glued onto a cover layer (30a, 30b) of the serially following arrangement.
6. The arrangement of claims 1 and 3 to 5, wherein in addition a first burn-through-proof CFK insulation layer (45) is glued onto the outer surface of the top-supported and/or the bottom-supported cover layer (30a, 30b) which comprises a second and a third to an nth burn-through-proof CFK insulation layer (45) which ends the layer design of the honeycomb panelling (22) which is glued onto the adjacent support areas of the cover layers (30a, 30b).
7. The arrangement of claim 2, wherein the construction of the honeycomb panelling (22), apart from that first CFK barrier layer (49), is additionally

supplemented by a second CFK barrier layer (52), which is supported towards the inner surface of the respective cover layer (30a, 30b) and towards the paper honeycombs (27) and is glued to the latter.

- 5 8. The arrangement of claim 3, wherein the paper honeycombs (27) of the individual honeycomb formation (46 to 48) have been replaced by aramide honeycombs (Nomex honeycombs).
9. The arrangement of claim 5, wherein the individual CFK insulation layer (45)
10 comprises a thick or thin CFK insulation layer.
10. The arrangement of claim 9, wherein the thin CFK insulation layer (45) comprises a burn-through-proof plastic foil.
- 15 11. The arrangement of claim 7, wherein the first and second CFK barrier layer (49, 52), as well as the further CFK barrier layers (53), comprise a thick or thin CFK barrier layer.
12. The arrangement of claim 11, wherein the further CFK barrier layers (53)
20 comprise a thin CFK barrier layer.
13. The arrangement of one of claims 11 and 12, wherein the thin CFK barrier layers (49, 52, 53) comprise a burn-through-proof plastic foil.
- 25 14. The arrangement of claim 1, wherein a point of adhesive bond (54) of the glued honeycomb panelling elements is implemented using a burn-through-proof adhesive means, preferably a resin, into which various resin components are integrated, or that the point of adhesive bond (54) of the honeycomb panelling elements is embodied under the influence of heat and
30 pressure to which said elements are technologically exposed in an enclosed space.

15. The arrangement of claim 14, wherein the point of adhesive bond (54) of the glued-together honeycomb panelling elements is made non-detachable and burn-through proof through the influence of the flames of a locally acting fire.
- 5 16. The arrangement of claim 3 or 6, wherein an insulation package (55) is arranged on the GFK cover layer (30b) supported below the honeycomb formation (46 to 48) or the burn-through-proof CFK insulation layer (45) whose outer surface faces the outer skin (33), wherein said insulation package (55) comprises burn-through-proof insulation which is enclosed by a burn-through-proof foil (11), or comprises the burn-through-proof insulation (56) 10 or the latter and non-burn-through-proof insulation (57), which are arranged side by side, or comprises the non-burn-through-proof insulation (57) into which a burn-through-proof barrier layer (58) is integrated, wherein the barrier layer extends without interruption through the non-burn-through-proof 15 insulation (57) right to the circumference of the insulation (57).
17. The arrangement of claim 16, wherein the bottom-supported GFK cover layer (30b) and the burn-through-proof CFK insulation layer (48) comprise a threaded drill hole (59) which extends perpendicular to the surface of this 20 GFK cover layer (30b).
18. The arrangement of one of claims 16 and 17, wherein the insulation package (55) comprises a hole-like leadthrough (60) which is congruent with a threaded drill hole (59), provided the insulation package (55) is aligned to the 25 outer surface of the bottom-supported GFK cover layer (30b) or of the burn-through-proof CFK insulation layer (45).
19. The arrangement of one of claims 16 to 18, wherein the insulation package (55) is attached to the bottom-supported GFK cover layer (30b) by means of a 30 burn-through-proof connection element (61) which is fed through the hole-like leadthrough (60) and which can be screwed into the threaded drill hole (59).

20. Insulation system for an outer skin (33) of a vehicle, comprising:
a plurality of honeycombs (27, 28) arranged side by side;
wherein each of the plurality of honeycombs (27, 28) has a
honeycomb body (23) each having both ends;
5 at least two cover layers (30) including a top-supported cover layer
(30a) and a bottom-supported cover layer (30b);
wherein the honeycomb bodies are supported by and glued to the at
least two cover layers (30) such that the top-supported cover layer (30a) is
arranged for facing an interior of the vehicle, and the bottom-supported cover
10 layer (30b) is arranged for facing the outer skin;
wherein the honeycomb bodies (23) are sandwiched between the at
least two cover layers (30a, 30b);
wherein the honeycombs are paper- or aramide honeycombs (27, 28);
a CFK layer;
15 wherein the CFK layer is respectively arranged on both ends of the
honeycomb bodies.
21. The insulation system of claim 20, further comprising:
further CFK insulation layers (45) which are glued to outer surfaces of
20 the at least two cover layers (30a, 30b).
22. The insulation system of one of claims 20 or 21, wherein the at least two
cover layers (30a, 30b) further comprise at least one of a further CFK layer, a
GFK layer, and further honeycomb formations (47) additionally stacked on
25 and glued to the plurality of honeycombs.

PRIOR ART

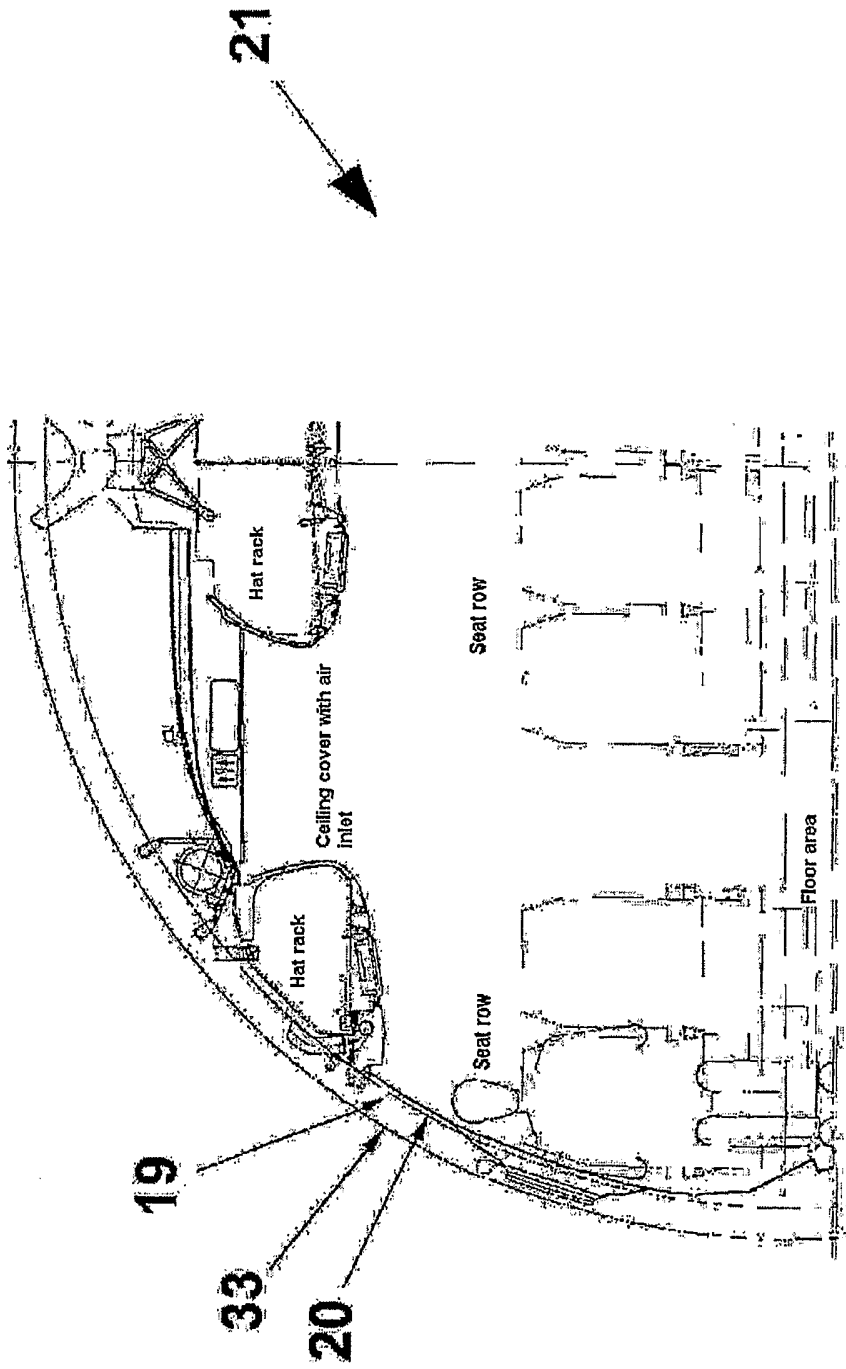

Fig. 1

PRIOR ART

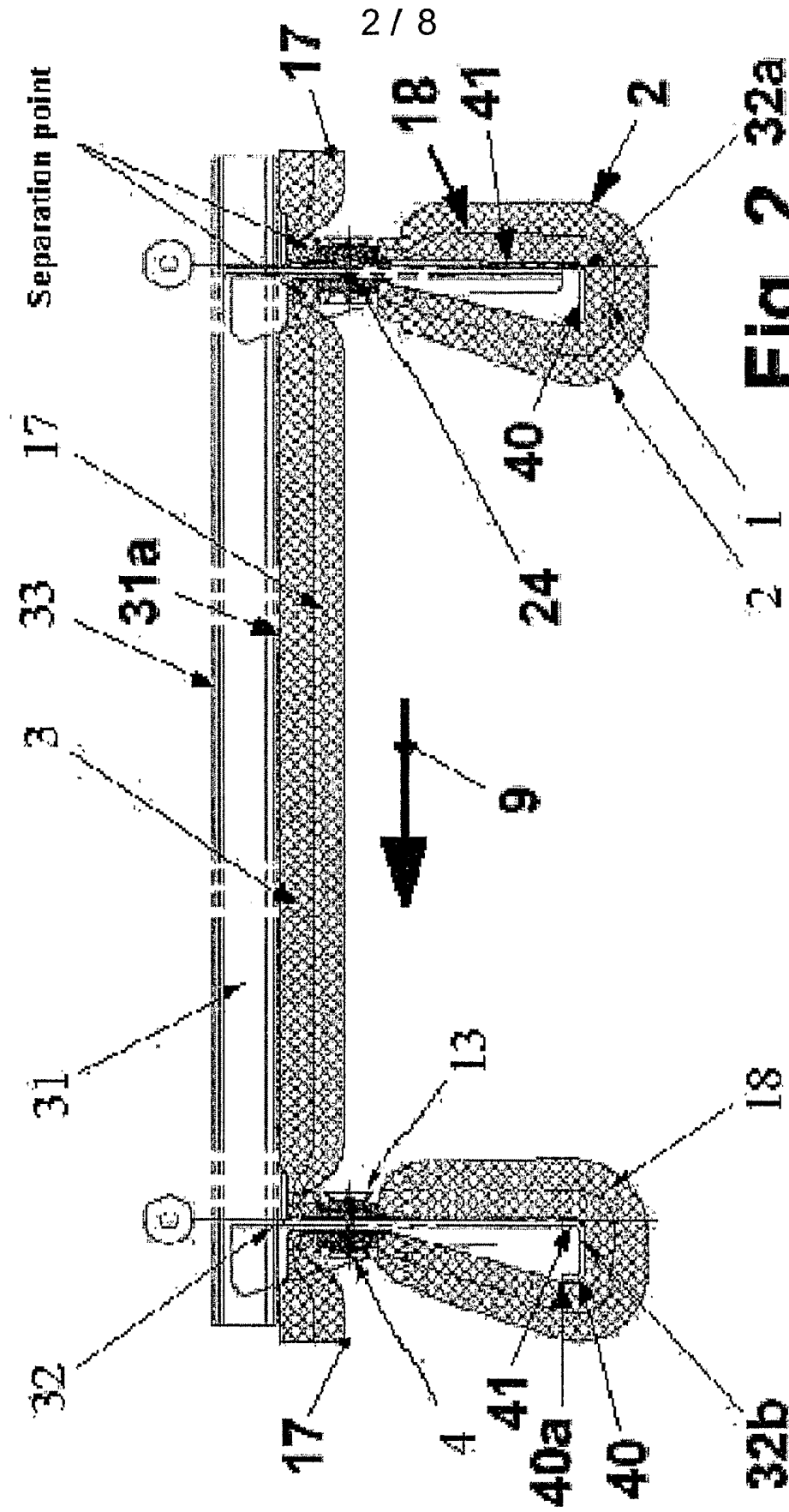

Fig. 2 32a

32b

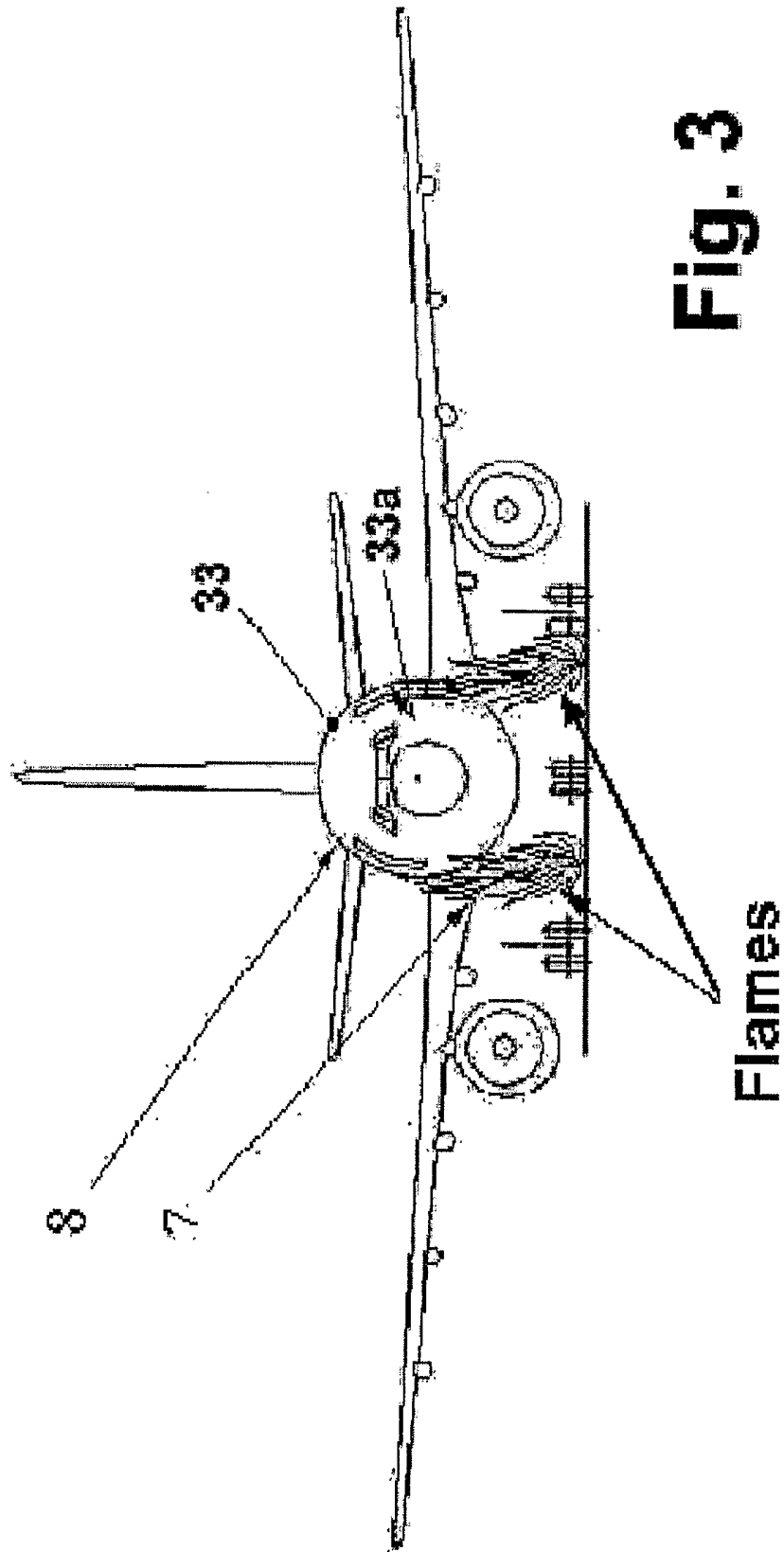

Fig. 3

PRIOR ART

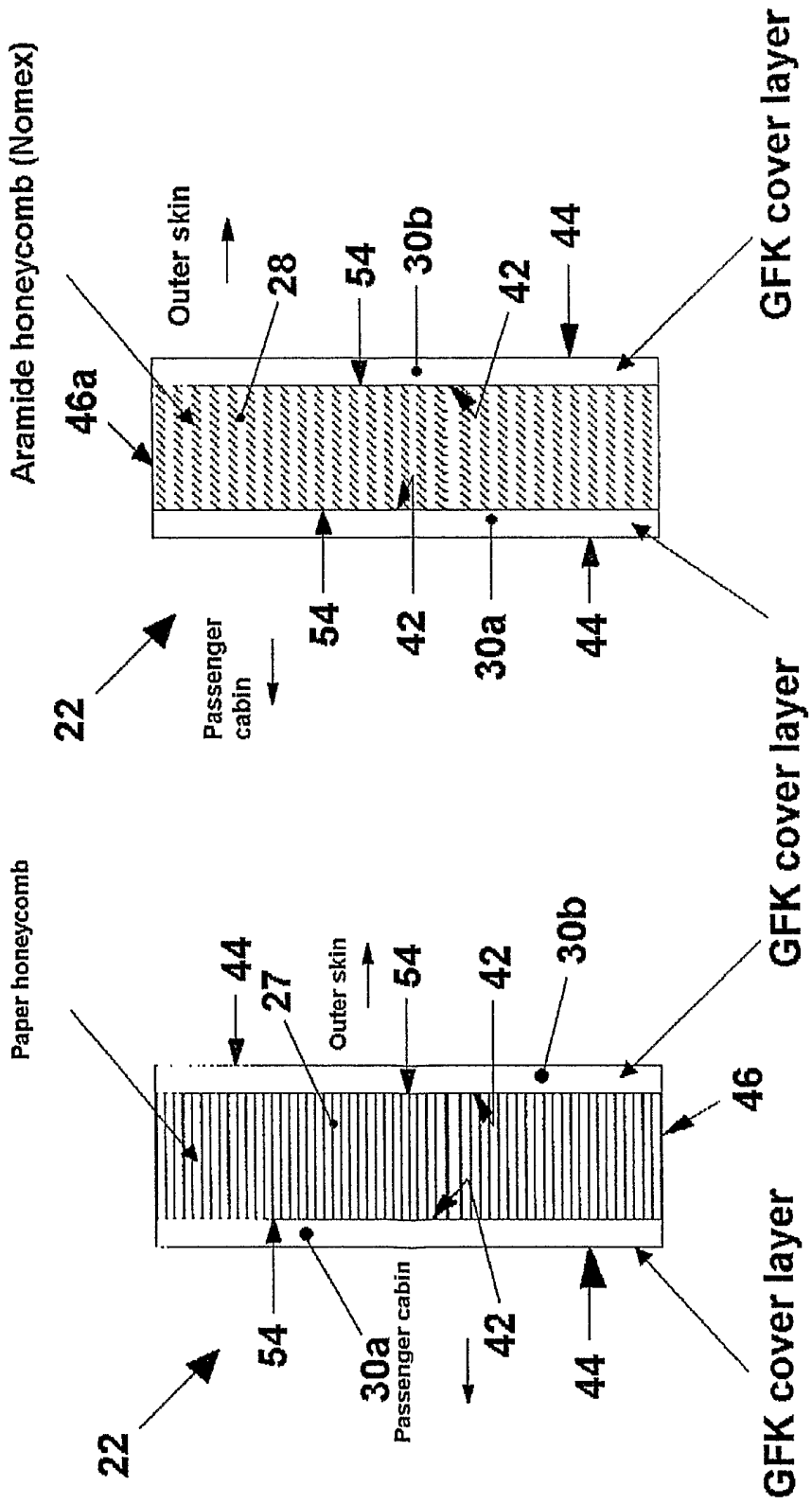
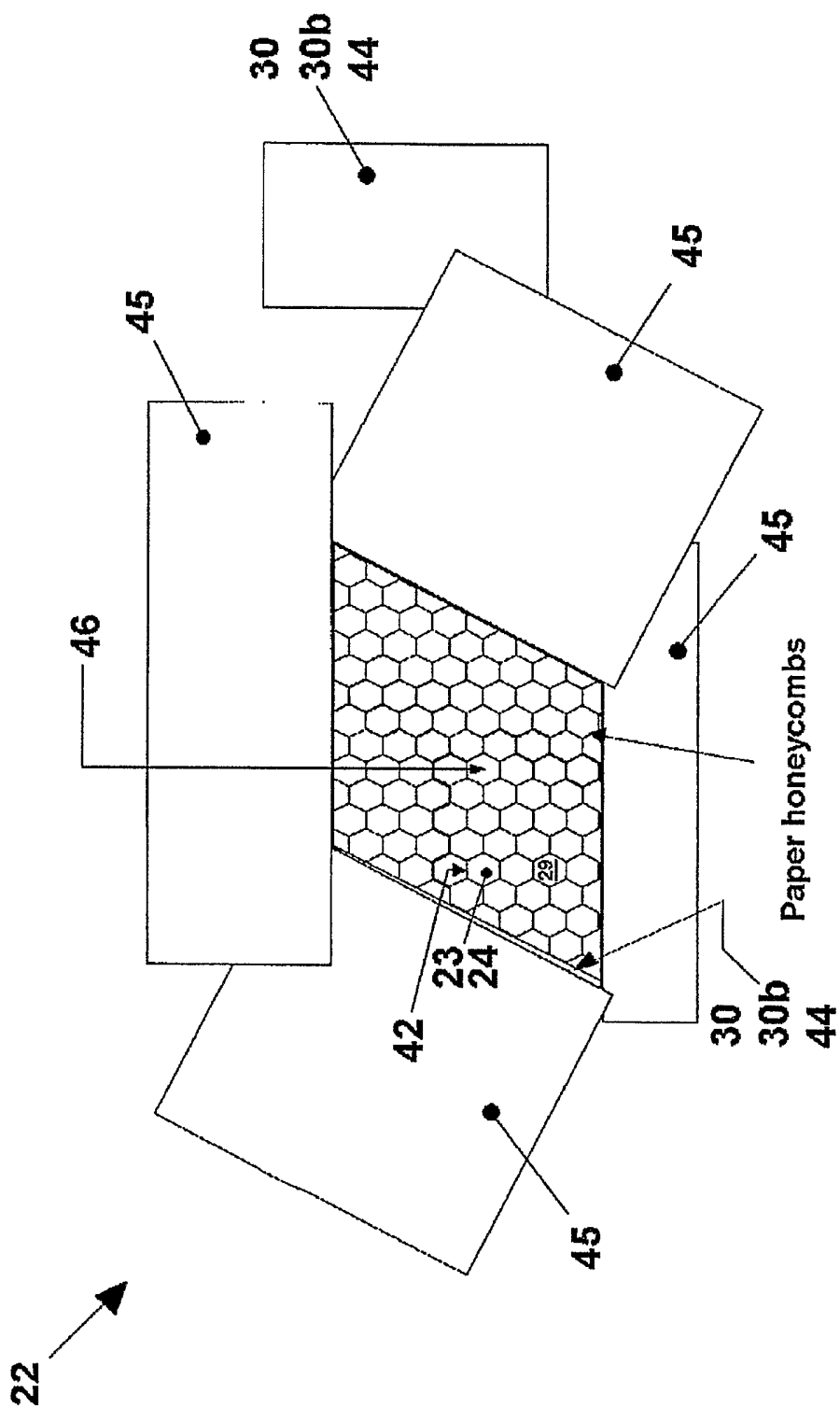

Fig. 4

Fig. 6



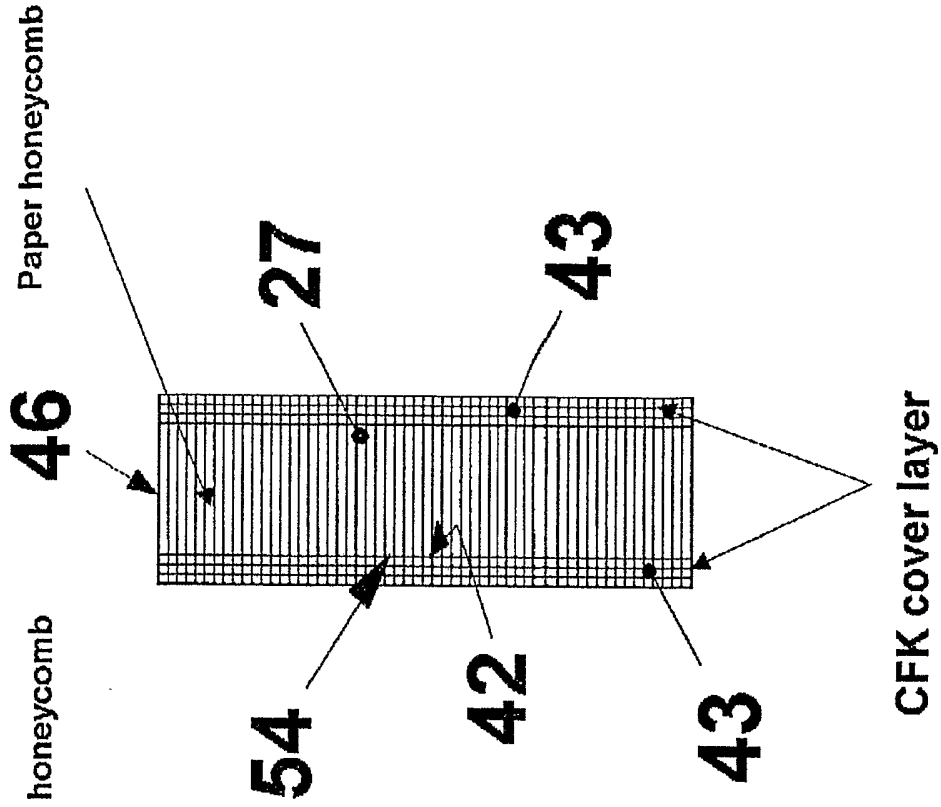

Fig. 5

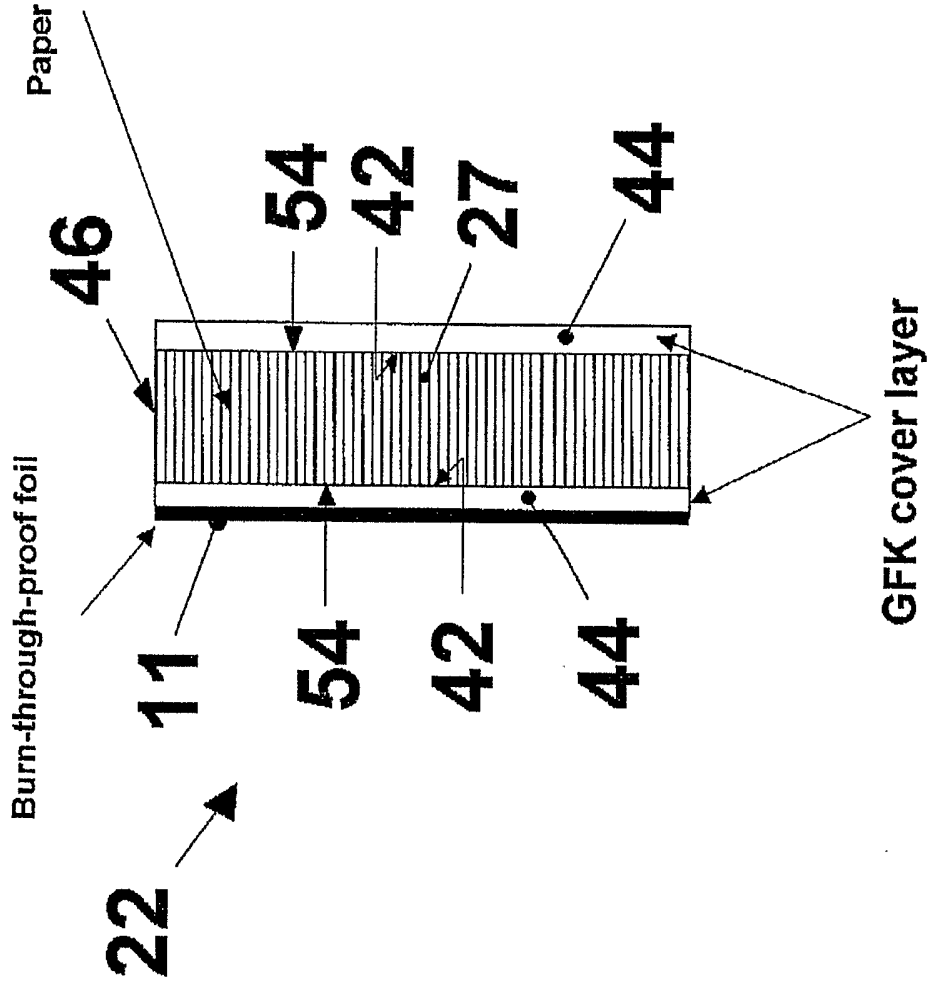

Fig. 8

Fig. 9a

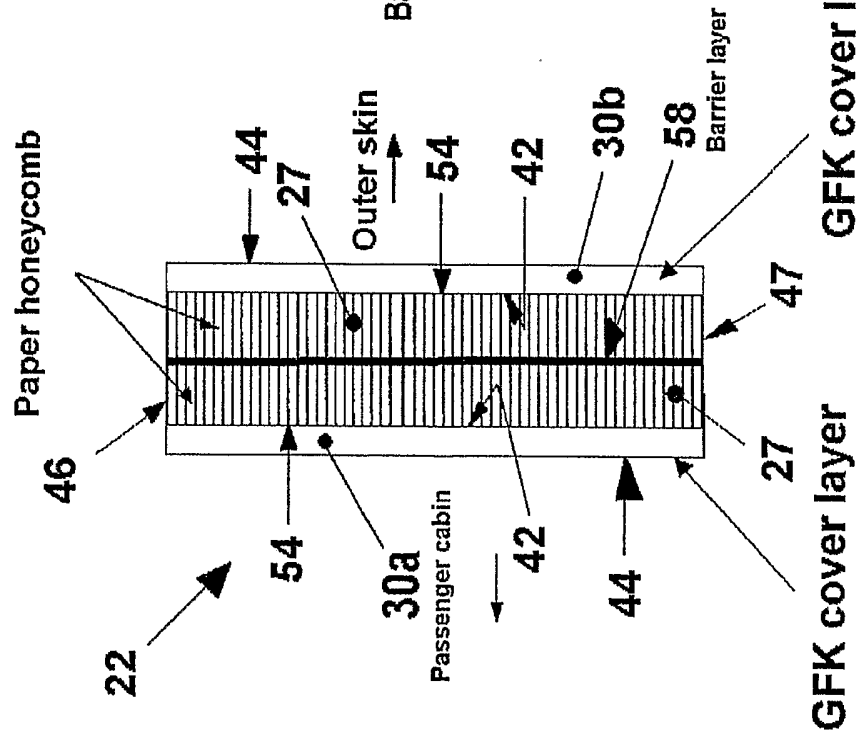

Fig. 9b

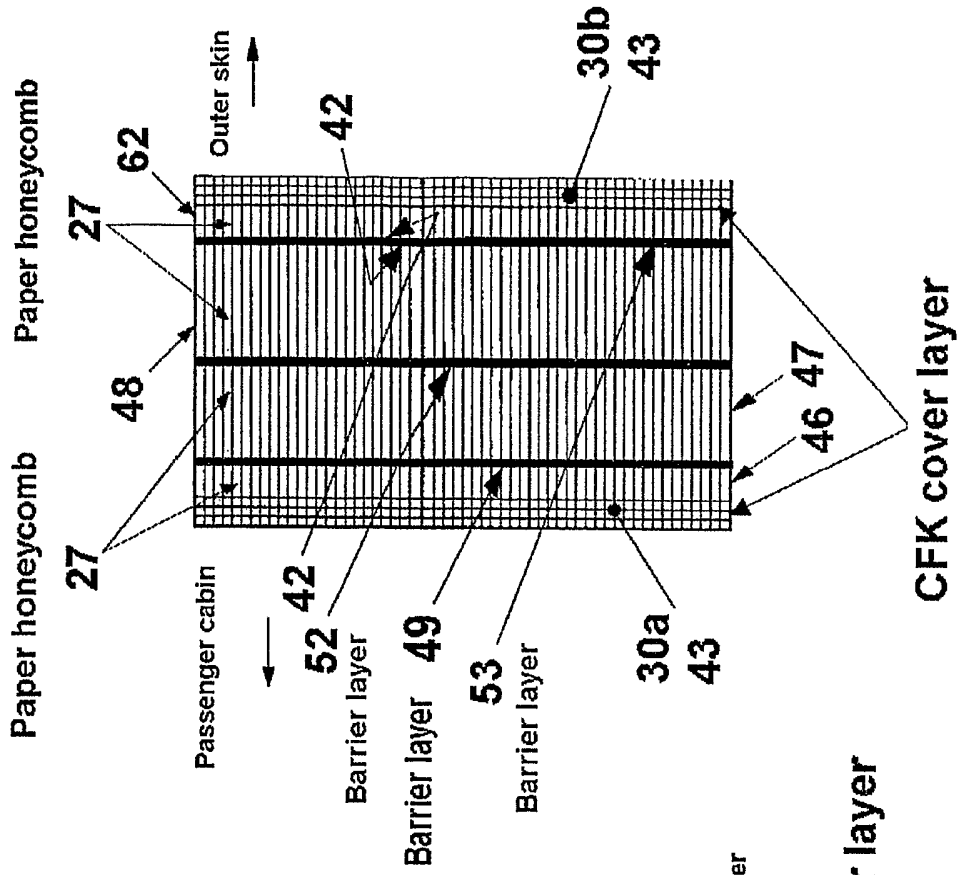

Fig. 10

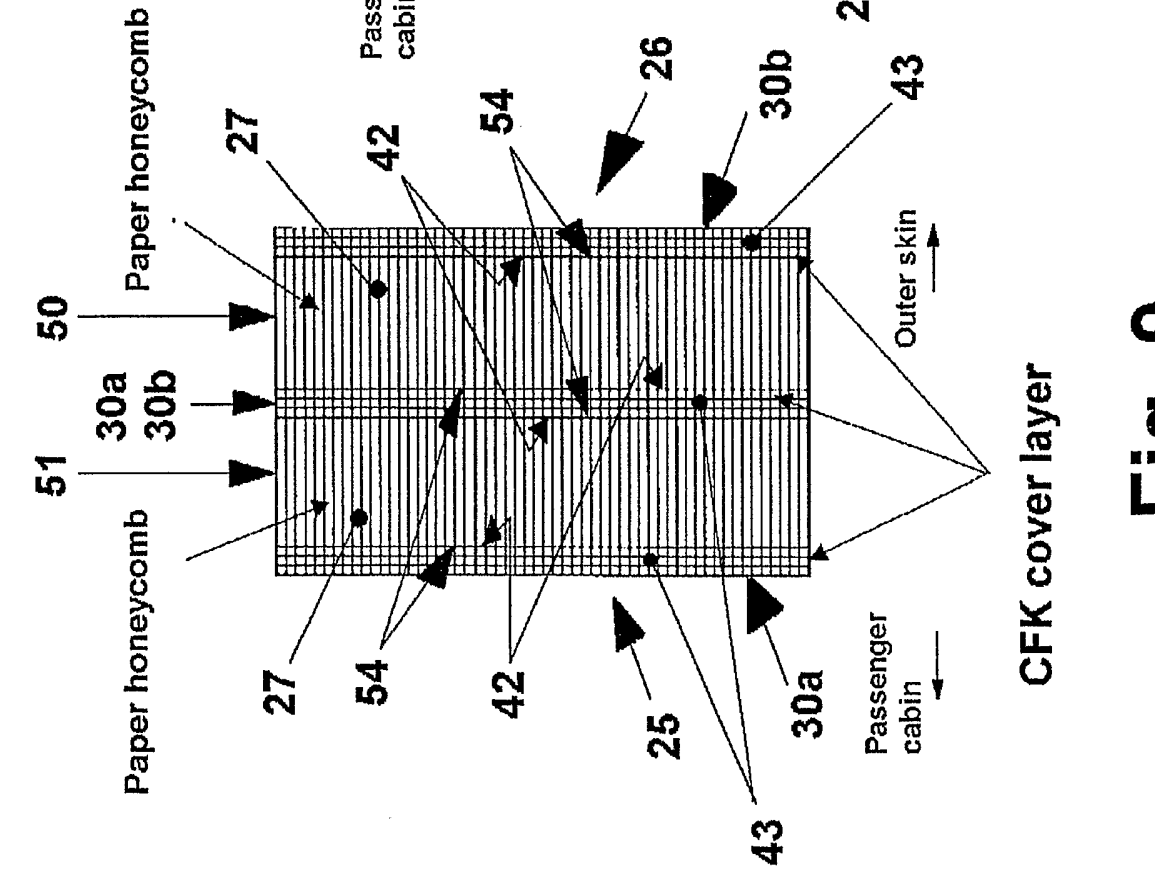
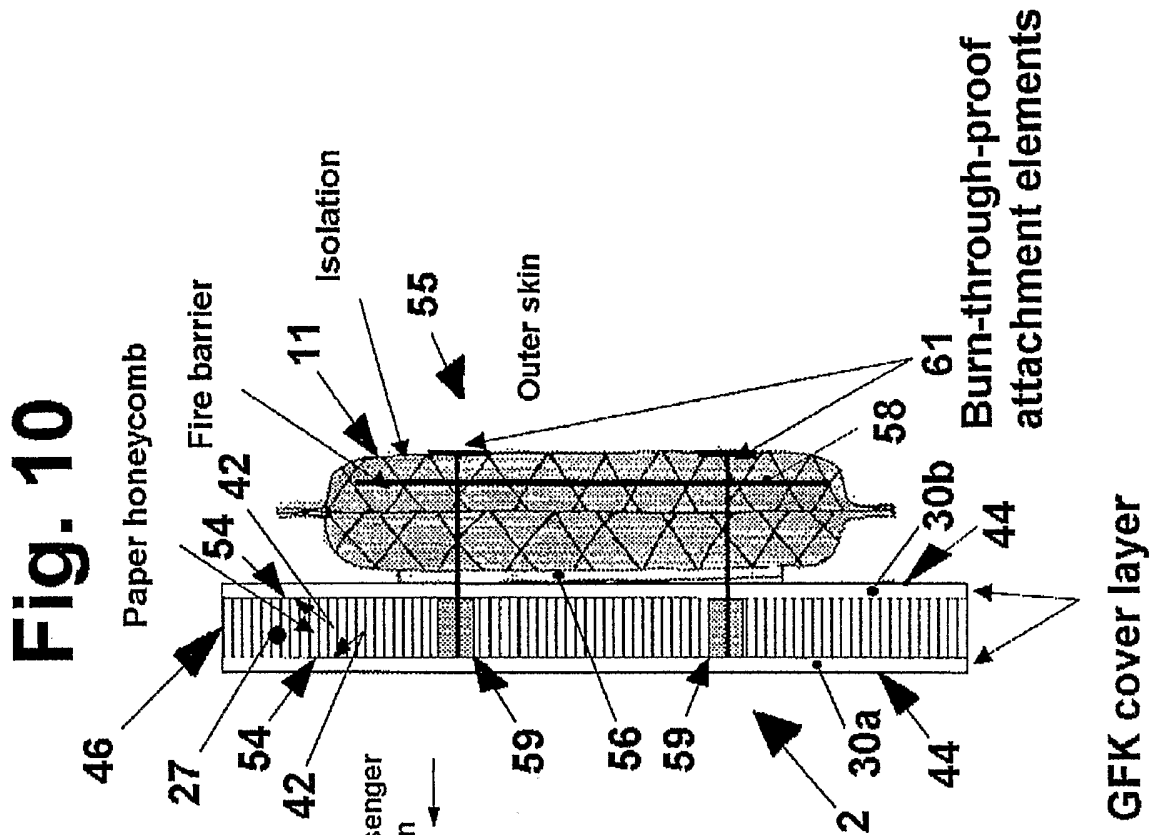

Fig. 9

INTERNATIONAL SEARCH REPORT

International Application No
PCT/EP2005/000040

A. CLASSIFICATION OF SUBJECT MATTER IPC 7 B64C1/12 B32B3/12 B64C1/40				
According to International Patent Classification (IPC) or to both national classification and IPC				
B. FIELDS SEARCHED				
Minimum documentation searched (classification system followed by classification symbols) IPC 7 B64C B32B				
Documentation searched other than minimum documentation to the extent that such documents are included in the fields searched				
Electronic data base consulted during the international search (name of data base and, where practical, search terms used) EPO-Internal, WPI Data, PAJ, COMPENDEX				
C. DOCUMENTS CONSIDERED TO BE RELEVANT				
Category °	Citation of document, with indication, where appropriate, of the relevant passages	Relevant to claim No.		
Y	EP 0 279 620 A (ADVANCED TECHNOLOGY & RESEARCH INC; ATR INTERNATIONAL, INC) 24 August 1988 (1988-08-24) abstract	1,2,4,5, 7-9,11, 12,14, 20-22		
Y	EP 0 624 462 A (CIBA-GEIGY AG) 17 November 1994 (1994-11-17) the whole document	1,2,4,5, 7-9,11, 12,22		
Y	US 4 759 964 A (FISCHER ET AL) 26 July 1988 (1988-07-26) the whole document	20-22		
Y	US 6 511 730 B1 (BLAIR F. DANA ET AL) 28 January 2003 (2003-01-28) abstract	14		
----- -/--				
<input checked="" type="checkbox"/> Further documents are listed in the continuation of box C.				
<input checked="" type="checkbox"/> Patent family members are listed in annex.				
° Special categories of cited documents :				
<table style="width: 100%; border: none;"> <tr> <td style="width: 50%; border: none; vertical-align: top;"> <ul style="list-style-type: none"> *A* document defining the general state of the art which is not considered to be of particular relevance *E* earlier document but published on or after the international filing date *L* document which may throw doubts on priority claim(s) or which is cited to establish the publication date of another citation or other special reason (as specified) *O* document referring to an oral disclosure, use, exhibition or other means *P* document published prior to the international filing date but later than the priority date claimed </td> <td style="width: 50%; border: none; vertical-align: top;"> <ul style="list-style-type: none"> *T* later document published after the international filing date or priority date and not in conflict with the application but cited to understand the principle or theory underlying the invention *X* document of particular relevance; the claimed invention cannot be considered novel or cannot be considered to involve an inventive step when the document is taken alone *Y* document of particular relevance; the claimed invention cannot be considered to involve an inventive step when the document is combined with one or more other such documents, such combination being obvious to a person skilled in the art. *&* document member of the same patent family </td> </tr> </table>			<ul style="list-style-type: none"> *A* document defining the general state of the art which is not considered to be of particular relevance *E* earlier document but published on or after the international filing date *L* document which may throw doubts on priority claim(s) or which is cited to establish the publication date of another citation or other special reason (as specified) *O* document referring to an oral disclosure, use, exhibition or other means *P* document published prior to the international filing date but later than the priority date claimed 	<ul style="list-style-type: none"> *T* later document published after the international filing date or priority date and not in conflict with the application but cited to understand the principle or theory underlying the invention *X* document of particular relevance; the claimed invention cannot be considered novel or cannot be considered to involve an inventive step when the document is taken alone *Y* document of particular relevance; the claimed invention cannot be considered to involve an inventive step when the document is combined with one or more other such documents, such combination being obvious to a person skilled in the art. *&* document member of the same patent family
<ul style="list-style-type: none"> *A* document defining the general state of the art which is not considered to be of particular relevance *E* earlier document but published on or after the international filing date *L* document which may throw doubts on priority claim(s) or which is cited to establish the publication date of another citation or other special reason (as specified) *O* document referring to an oral disclosure, use, exhibition or other means *P* document published prior to the international filing date but later than the priority date claimed 	<ul style="list-style-type: none"> *T* later document published after the international filing date or priority date and not in conflict with the application but cited to understand the principle or theory underlying the invention *X* document of particular relevance; the claimed invention cannot be considered novel or cannot be considered to involve an inventive step when the document is taken alone *Y* document of particular relevance; the claimed invention cannot be considered to involve an inventive step when the document is combined with one or more other such documents, such combination being obvious to a person skilled in the art. *&* document member of the same patent family 			
Date of the actual completion of the international search <p style="text-align: center;">14 April 2005</p>	Date of mailing of the international search report <p style="text-align: center;">21/04/2005</p>			
Name and mailing address of the ISA European Patent Office, P.B. 5818 Patentlaan 2 NL - 2280 HV Rijswijk Tel. (+31-70) 340-2040, Tx. 31 651 epo nl, Fax: (+31-70) 340-3016	Authorized officer <p style="text-align: center;">Calvo De No, R</p>			

INTERNATIONAL SEARCH REPORT

International Application No
PCT/EP2005/000040

C.(Continuation) DOCUMENTS CONSIDERED TO BE RELEVANT		
Category °	Citation of document, with indication, where appropriate, of the relevant passages	Relevant to claim No.
A	EP 1 055 513 A (HEXCEL CORPORATION) 29 November 2000 (2000-11-29) the whole document -----	1,20
A	US 4 299 872 A (MIGUEL ET AL) 10 November 1981 (1981-11-10) the whole document -----	1,20
A	US 3 811 997 A (YUAN E,US) 21 May 1974 (1974-05-21) the whole document -----	1,20
A	US 4 567 076 A (THERRIEN ET AL) 28 January 1986 (1986-01-28) abstract -----	1,20

INTERNATIONAL SEARCH REPORT

Information on patent family members

International Application No

PCT/EP2005/000040

Patent document cited in search report	A	Publication date	Patent family member(s)	Publication date
EP 0279620	A	24-08-1988	US 4799631 A AT 90294 T CA 1316164 C DE 3881539 D1 DE 3881539 T2 EP 0279620 A2	24-01-1989 15-06-1993 13-04-1993 15-07-1993 04-11-1993 24-08-1988
EP 0624462	A	17-11-1994	US 5460864 A CA 2122961 A1 EP 0624462 A1 JP 6328599 A ZA 9403150 A	24-10-1995 08-11-1994 17-11-1994 29-11-1994 07-11-1994
US 4759964	A	26-07-1988	AT 384189 B AT 360983 A DE 3625534 A1 FR 2607442 A1 GB 2197820 A	12-10-1987 15-03-1987 11-02-1988 03-06-1988 02-06-1988
US 6511730	B1	28-01-2003	EP 1055513 A1 AU 3881600 A CA 2372750 A1 EP 1189747 A1 WO 0073055 A1	29-11-2000 18-12-2000 07-12-2000 27-03-2002 07-12-2000
EP 1055513	A	29-11-2000	EP 1055513 A1 AU 3881600 A CA 2372750 A1 EP 1189747 A1 WO 0073055 A1 US 6511730 B1	29-11-2000 18-12-2000 07-12-2000 27-03-2002 07-12-2000 28-01-2003
US 4299872	A	10-11-1981	NONE	
US 3811997	A	21-05-1974	NONE	
US 4567076	A	28-01-1986	NONE	