

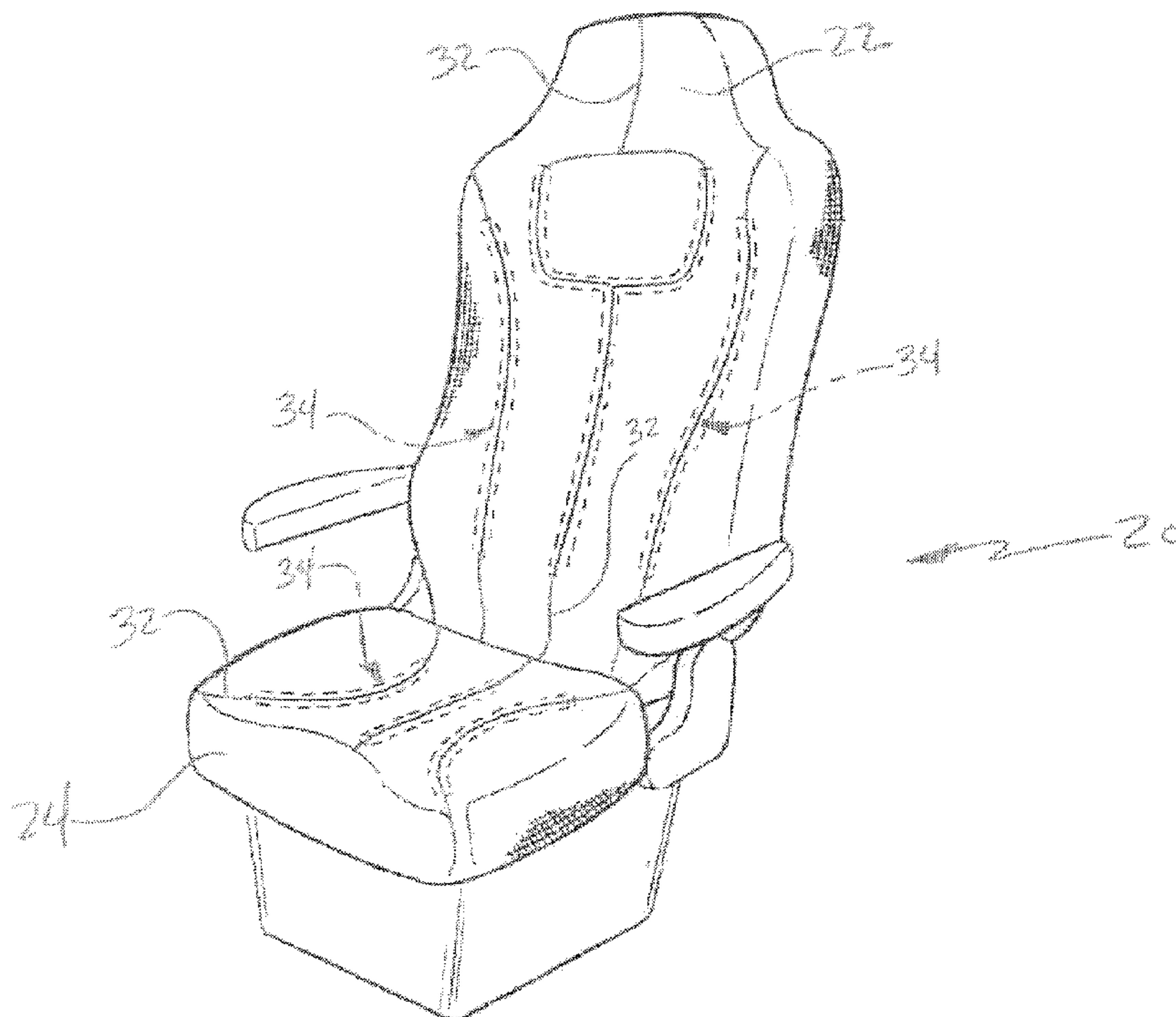

(22) Date de dépôt/Filing Date: 2002/01/21
(41) Mise à la disp. pub./Open to Public Insp.: 2002/07/19
(30) Priorité/Priority: 2001/01/19 (60/262,752) US

(51) Cl.Int.⁷/Int.Cl.⁷ B60N 2/58
(71) Demandeur/Applicant:
INTIER AUTOMOTIVE INC., CA
(72) Inventeurs/Inventors:
STILLER, EDWIN L., US;
WYATT, DANIEL C., US
(74) Agent: IMAI, JEFFREY T.

(54) Titre : ATTACHES POUR SIEGE DE VEHICULE
(54) Title: VEHICLE SEAT FASTENER ASSEMBLY



(57) Abrégé/Abstract:

A fastener assembly for securing a trim cover to a contoured foam pad of a seat. The fastener assembly comprises a restraint portion secured to the trim cover and a locking portion secured to the foam pad. The locking portion includes a plurality of clips for engaging the restraint portion to retain the restraint portion to the locking portion during a mounting of the trim cover over the foam pad. The locking portion also includes alternating bases, supporting the clips, and flexible sections such that the locking portion can be manipulated and conform to the contoured foam pad. The restraint portion further includes a plurality of apertures to provide a visual alignment feature between the restraint portion and the locking portion for properly aligning the trim cover with the foam pad during a mounting of the trim cover over the foam pad.

ABSTRACT OF THE DISCLOSURE

A fastener assembly for securing a trim cover to a contoured foam pad of a seat.

- 5 The fastener assembly comprises a restraint portion secured to the trim cover and a locking portion secured to the foam pad. The locking portion includes a plurality of clips for engaging the restraint portion to retain the restraint portion to the locking portion during a mounting of the trim cover over the foam pad. The locking portion also includes alternating bases, supporting the clips, and flexible sections such that the locking portion
- 10 can be manipulated and conform to the contoured foam pad. The restraint portion further includes a plurality of apertures to provide a visual alignment feature between the restraint portion and the locking portion for properly aligning the trim cover with the foam pad during a mounting of the trim cover over the foam pad.

VEHICLE SEAT FASTENER ASSEMBLY

BACKGROUND OF THE INVENTION

1. Field of the Invention

5 [0001] The subject invention relates to a fastener assembly for a vehicle seat to secure a trim cover to a foam pad.

2. Description of the Prior Art

10 [0002] During the manufacture of automotive seat cushions and seat backs, a trim cover is typically affixed to a foam pad. As appreciated, most seat cushions and seat backs include trenches and other styling lines. Fasteners are usually mounted to the trim cover and foam pad along these style lines to secure the trim cover to the foam pad. These fasteners also act as a locator to assist in correctly positioning the trim cover over the foam pad.

15 [0003] One such fastener for affixing the trim cover to the foam pad utilizes hook and loop fasteners, such as shown in U.S. Patent No. 5,236,243. In particular, the hook fastener is mounted to the trim cover and the loop fastener is mounted to a corresponding area of the foam pad. During installation, the hook fastener is overlaid upon the loop fastener to secure the trim cover to the foam pad. The hook and loop fasteners, however, are expensive and prone to misalignment. In addition, the hook and loop fasteners do not include any type of
20 visual or mechanical alignment devices.

[0004] Another common method, such as shown in U.S. Patent No. 4,865,383, utilizes what is known in the art as hog rings. The hog rings method has a number of preformed wires conforming to the unique contours of the foam pad and small rings or hooks sewn or otherwise mounted to the trim cover. During installation, the rings engage and secure to the wires which in turn secures the trim cover to the foam pad. Although the material to manufacture the rings and wires is inexpensive, the hog ring wires must be custom designed to conform to the various contours of each foam pad. In other words, there are a number of unique wires for both the seat cushion and seat back foam pads of each seat. Further, connecting the hog rings to the wires is a difficult assembly requiring a large effort by the installer. Finally, the hog ring method does not include any type of visual or mechanical alignment device.

[0005] Yet another design of the fasteners includes a plastic base molded into the foam pad and a plastic strip sewn to the trim cover. Examples of these fasteners are shown in U.S. Patent Nos. 3,794,378 and 5,964,017. Either the base or the strip has a locking portion and the other has a retaining portion. During installation of the trim cover over the foam pad, the locking portion engages the retaining portion to secure the trim cover to the foam pad. Although easier to install than the hog rings, these plastic fasteners also have a number of deficiencies. First, the fasteners are relatively stiff and therefore create hard channels in the seat which can be uncomfortable. Secondly, these stiff fasteners can have difficulty conforming to the contours of a seat cushion or seat back. Finally, the plastic fasteners do not include any type of visual or mechanical alignment devices.

[0006] Accordingly, it would be desirable to provide a fastener assembly for a trim cover which is inexpensive to manufacture, can be used on a wide range of foam pad designs, provides a comfortable seating surface, prevents misalignment, and is easy to install.

5

SUMMARY OF THE INVENTION AND ADVANTAGES

[0007] A fastener assembly for securing a trim cover to a contoured foam pad of a seat. The fastener assembly comprises a restraint portion secured to the trim cover and a locking portion secured to the foam pad. The locking portion includes a least one clip for selectively engaging the restraint portion to retain the restraint portion to the locking portion during a mounting of the trim cover over the foam pad. The locking portion further includes at least one base with the base having at least one flexible section such that the locking portion can be manipulated and conform to the contoured foam pad.

[0008] The restraint portion also includes a plurality of apertures formed therein. Preferably, the locking portion includes at plurality of spaced clips. The spaced clips selectively engage and retain the restraint portion and extending into the apertures to provide a visual alignment feature between the restraint portion and the locking portion for properly aligning the trim cover with the foam pad during a mounting of the trim cover over the foam pad.

BRIEF DESCRIPTION OF THE DRAWINGS

[0009] Other advantages of the present invention will be readily appreciated as the same becomes better understood by reference to the following detailed description when considered in connection with the accompanying drawings wherein:

5 [0010] Figure 1 is a perspective view of an automotive seat incorporating a fastener assembly therein;

[0011] Figure 2 is a fragmentary perspective view of the seat further illustrating the fastener assembly;

[0012] Figure 3 is a perspective view of the fastener assembly including a restraint portion
10 and a locking portion with the portions being disengaged;

[0013] Figure 4 is a top view of the fastener assembly illustrating the flexibility of the assembly;

[0014] Figure 5 is a side view of the fastener assembly further illustrating the flexibility of the assembly;

15 [0015] Figure 6 is a perspective of the fastener assembly with the restraint portion engaged with the locking portion;

[0016] Figure 7 is a cross sectional side view of the fastener assembly with the restraint portion disengaged from the locking portion;

[0017] Figure 8 is a cross sectional side view of the fastener assembly with the restraint
20 portion engaged to the locking portion;

[0018] Figure 9 is a perspective view of a molding assembly having contoured ridges;

[0019] Figure 10 is a cross sectional side view of the molding assembly;

[0020] Figure 11 is a cross sectional side view of the molding assembly with the locking portion of the fastener assembly attached thereto.

5 DETAILED DESCRIPTION OF THE PREFERRED EMBODIMENT

[0021] Referring to the Figures, wherein like numerals indicate like or corresponding parts throughout the several views, an automotive seat is generally shown at 20 in Figure 1. The seat 20 includes a seat back 22 and a seat cushion 24. Referring also to Figure 2, both the seat back 22 and seat cushion 24 are formed of a contoured foam pad 26 having
10 a contoured outer surface 28. A trim cover 30 at least partially covers the outer surface 28 of the foam pad 26 as is known in the art. The trim cover 30 is typically a combination of sewn pieces which allow the trim cover 30 to conform to the contours of the foam pad 26. When the trim cover 30 is sewn together this creates seams or styling lines 32 in the trim cover 30. The trim cover 30 may be cloth, vinyl, leather, or the like. In addition, the seat
15 back 22 and seat cushion 24 may be of any suitable design or configuration.

[0022] As shown in Figure 2 and in phantom in Figure 1, a number of fastener assemblies 34 secure the trim cover 30 to the foam pad 26. The fastener assemblies 34 illustrated are examples of one implementation for the subject invention. It should be appreciated that fastener assemblies 34 of the subject invention may be incorporated into any component of
20 the seat 20 in any suitable configuration as is known to those in the seating art. The fastener assemblies 34 of the subject invention are particularly useful for leather trim covers due to

the limited capability of adhering leather to foam pads and for cloth trim covers where the trim cover is not molded in-place or bonded to the foam pad.

[0023] The foam pad 26 has at least one elongated groove 36 formed within the foam pad 26 below the outer surface 28. As discussed in greater detail below, the groove 36 is designed to house the fastener assembly 34 such that the trim cover 30 can be secured to the foam pad 26 along the grooves 36. The grooves 36 also track the styling lines 32 in the trim cover 30. Hence, for example, there are three styling lines 32 in the trim cover 30 for the seat bottom 24. Accordingly, there are preferably three grooves 36 formed in the foam pad 26 of the seat bottom 24. Also, the groove 36 includes a contoured section 38, which defines curves and valleys for the styling lines 32. Preferably, the groove 36 will have multiple contoured sections 38 depending upon the shape, design, and configuration of the foam pads 26 for the seat back 22 and seat bottom 24. Even more preferably, the contoured section 38 of the groove 36 is substantially parallel to the contoured outer surface 28 of the foam pad 26 such that the groove 36 maintains a substantially even depth.

[0024] Referring also to Figures 3 and 6, the fastener assembly 34 is shown in greater detail. In particular, the fastener assembly 34 comprises a restraint portion 40 and a locking portion 42. Figure 3 illustrates the restraint portion 40 disengaged from the locking portion 42 and Figure 6 illustrates the restraint portion 40 engaged with the locking portion 42.

[0025] The locking portion 42 includes at least one clip 44 for selectively engaging the restraint portion 40 to retain the restraint portion 40 to the locking portion 42 during a mounting of the trim cover 30 over the foam pad 26. The clip 44 includes opposing legs 46 with each of the legs 46 having a barb 48.

5 [0026] The locking portion 42 further includes at least one base 50 with the base 50 having at least one flexible section 52 such that the locking portion 42 can be manipulated and conform to the contoured foam pad 26. Preferably, the locking portion 42 includes a plurality of bases 50 and a plurality of flexible sections 52. In addition, the locking portion 42 preferably includes a plurality of clips 44 with at least one clip 44 disposed on
10 each of the bases 50.

[0027] Each of the flexible sections 52 are further defined as a connecting arm 52 with the arm interlinking the bases 50 to form a series of bases 50 and arms 52. The most preferred embodiment of the locking portion 42 includes the series of square bases 50 and rectangular arms 52 extending in an alternating fashion with one of the clips 44 centrally
15 disposed on each of the bases 50. The series of locking portions 42 creates a elongated flexible locking device which can be manipulated and conformed as shown in Figures 4 and 5. In particular, Figure 4 illustrates that the locking portion 42 can easily conform to relatively sharp turns or curves in the grooves 36 and Figure 5 illustrates that the locking portion 42 can conform to rises and valleys in the grooves 36. Hence, the locking portions
20 42 are versatile in conforming to virtually any design or configuration of a complex surface which may be found on a foam pad 26. This greatly improves the flexibility of the design.

It should be appreciated that the locking portion 42 may be of any suitable design or configuration so long as the flexible characteristics of the locking portion 42 are maintained.

[0028] The bases 50, flexible sections 52, and clips 44 are preferably integrally formed of a polymeric material, *i.e.*, polypropylene, such that it may be easily formed and integrated within the foam pad 26.

[0029] The restraint portion 40 includes a plurality of apertures 54 formed therein. Preferably, there is a corresponding aperture 54 in the restraint portion 40 for each clip 44 on the locking portion 42. The apertures 54 provide a visual alignment when the restraint portion 40 is engaged with the plurality of clips 44 for properly aligning the trim cover 30 with the foam pad 26 during a mounting of the trim cover 30 over the foam pad 26. Preferably, the restraint portion 40 includes a flexible fabric 56 having a first end and a distal end with the apertures 54 formed within the flexible fabric 56. The flexible fabric 56 is of a particular material which provides a desired amount of tension force. Hence, any pulling or movement of the trim cover 30 will not rip or tear the fabric. The restraint portion 40 further includes a bulbous member 58 mounted to the distal end of the flexible fabric 56. Preferably, the bulbous member 58 is formed of a polymeric material.

[0030] As best shown in Figures 2, 7, and 8, the restraint portion 40 is sewn or otherwise affixed to the trim cover 30. The restraint portion 40 is preferably sewn into the seam 32 of the trim cover 30. Even more preferably, the first end of the flexible fabric 56 is sewn or otherwise secured to one of the seams 32 of the trim cover 30. The locking portion 42

is integrally molded into the grooves 36 of the foam pad 26 with the clips 44 extending into the groove 36. As appreciated, the locking portion 42 could be mounted to the foam pad 26 by other means such as adhesives or fasteners without deviating from the subject invention.

[0031] As best shown in Figure 8, when the restraint portion 40 is interlocked with the locking portion 42, the apertures 54 within the fabric 56 allow the locking clips 44 to substantially encompass a corresponding portion of the bulbous member 58. Preferably, the fabric 56 and the bulbous member 58 are of a length that correlates to the desired length of the locking portion 42.

[0032] Turning to Figures 9 through 11, a molding device 60 in accordance with the subject invention is shown. The molding device 60 includes an upper mold (not shown) and a lower mold 62 with at least one of the upper and lower 62 molds having a contoured ridge 64. The lower mold 62 illustrated in Figure 9 has three contoured ridges 64, which correspond to the three contoured ridges 64 of the foam pad 26 for the seat cushion 24.

[0033] Figure 10 illustrates a cross sectional view of the lower mold 62 about one of the ridges 64. A retaining flange 66 is mounted to the contoured center ridge 64 and extends upwardly therefrom. As shown in Figure 11, the retaining flange 66 engages the clip 44 of the locking portion 42 to position the locking portion 42 within the molding device 60 and to maintain the clip 44 free of the foam pad 26. A pocket 68 may also be formed within the ridge 64 such that the barbs 48 of the clip 44 extend into the ridge 64.

[0034] The method of forming the foam pad 26 and mounting the trim cover 30 to the foam pad 26 is now discussed in greater detail. Initially, the molding device 60 is free of

foaming material (not shown) which forms the foam pad 26. The locking portion 42 is mounted to at least one of the upper and lower molds 62 such that the locking portion 42 conforms to the contoured ridge 64. Preferably, the locking portion 42 is mounted to the retaining flange 66 such that the locking portion 42 conforms to the contoured ridge 64.

5 Even more preferably, the series of bases 50 and clips 44 are mounted in the molding device 60 with the clips 44 mounted to the retaining flange 66 to conform the entire locking portion 42 to the contoured ridge 64 along a majority of the length of the contoured ridge 64. The clips 44 may be held into position on the retaining flange 66 by frictional forces. In addition, a bead or other projection (not shown) may be provided on
10 the retaining flange 66 to assist in the retention of the clips 44.

[0035] The upper mold closes upon the lower mold 62 and the foaming material is introduced to the molding device 60 as is known in the seat manufacturing art. The foam pad 26 is then formed within the molding device 60. The groove 36 is also formed within the foam pad 26 at the contoured ridge 64 during the forming of the foam pad 26 wherein
15 the groove 36 includes the contoured section 38 or sections. The base 50 of the locking portion 42 is secured to the foam pad 26 within the contoured section 38 of the groove 36 during the forming of the foam pad 26, see Figure 11. It should be appreciated by those skilled in the art that the forming of the groove 36 within the foam pad 26 and the securing of the base 50 of the locking portion 42 to the foam pad 26 occur simultaneously during
20 the step of forming the foam pad 26. With the clips 44 positioned on the retaining flange 66, the clips 44 are protected from unwanted intrusion of foam material. It should be

appreciated that the presence of foam material between the clips 44 could significantly reduce the effective operation of the clips 44.

[0036] During the manufacture of the seat back 22 and seat cushion 24, the foam pad 26 is formed separately from the trim cover 30. Once the pieces of the trim cover 30 have been made, the trim cover 30 is sewn together with the restraint portion 40 being secured to the trim cover 30. As discussed above, the restraint portion 40 can be sewn within the seams or style lines 32 of the trim cover 30.

[0037] The foam pad 26, with the locking portion 42, is then removed from the molding device 60. The trim cover 30 is overlaid onto the foam pad 26 with the seams or style lines 32 being generally aligned with the grooves 36 in the foam pad 26 such that the restraint portions 40 are positioned at least partially within the grooves 36, see Figure 7.

The trim cover 30 is then manipulated and orientated to interlock the restraint portion 40 with the clip 44 of the locking portion 42 to secure the trim cover 30 to the foam pad 26.

Specifically, an installer visually aligns the first aperture 54 of the restraint portion 40 with the first clip 44 on the locking portion 42. Due to the relative positions of the apertures 54 and clips 44, aligning the first aperture 54 and clip 44 automatically aligns all of the apertures 54 and clips 44 as well as the entire fastener assembly 34.

[0038] The installer then pushes downward on the seam or style line 32 which pushes the bulbous member 58 into engagement with the locking clips 44. The legs 46 of the clips 44 deform slightly outward such that the bulbous member 58 may pass between the corresponding barbs 48. As appreciated, the clips 44 are substantially aligned with the

apertures 54 of the flexible fabric 56. Hence, the clips 44 are able to snap back into position such that the barbs 48 will substantially encapsulate the bulbous member 58, see Figure 8.

This procedure is repeated for each seam or style line 32. Accordingly, each of the restraint portions 40 are then engaged with a corresponding locking portion 42. The mechanical
5 engagement of the restraint portions 40 with the locking portions 42 creates a secure engagement between the trim cover 30 and the foam pad 26.

[0039] As discussed above, the fastener assembly 34 also ensures proper alignment of the seams or style lines 32 within the grooves 36 of the foam pad 26 which creates an aesthetically pleasing appearance. Due to the positioning of the fastener assemblies 34 and
10 the apertures 54, the trim cover 30 is correctly positioned onto the foam pad 26 in both horizontal directions as well as the vertical direction. The remaining portions of the trim cover 30 are then secured to the foam pad 26 as is known in the art.

[0040] Obviously, many modifications and variations of the present invention are possible in light of the above teachings and the invention may be practiced otherwise than as
15 specifically described within the scope of the appended claims.

CLAIMS

What is claimed is:

1. A fastener assembly for securing a trim cover to a contoured foam pad of a seat, said fastener assembly comprising;

5 a restraint portion adapted to be secured to the trim cover; and

a locking portion adapted to be secured to the foam pad;

said locking portion including at least one clip for selectively engaging said restraint portion to retain said restraint portion to said locking portion during a mounting of the trim cover over the foam pad; and

10 said locking portion further including at least one base with said base having at least one flexible section such that said locking portion can be manipulated and conform to the contoured foam pad.

2. An assembly as set forth in claim 1 wherein said locking portion further
15 includes a plurality of bases and a plurality of flexible sections.

3. An assembly as set forth in claim 2 wherein said locking portion further includes a plurality of clips with at least one clip 44 disposed on each of said bases.

4. An assembly as set forth in claim 3 wherein each of said flexible sections are further defined as a connecting arm 52 with said arm interlinking said bases to form a series of bases and arms.

5 5. An assembly as set forth in claim 4 wherein said series of bases and arms includes alternating bases and arms with one of said clips disposed on each of said bases.

6. An assembly as set forth in claim 3 wherein each of said clips include opposing legs with said legs having a barb.

10

7. An assembly as set forth in claim 3 wherein said bases, flexible sections, and clips are integrally formed of a polymeric material.

8. An assembly as set forth in claim 3 wherein said restraint portion includes a
15 plurality of apertures formed therein to provide a visual alignment when said restraint portion is engaged with said plurality of clips for properly aligning the trim cover with the foam pad during a mounting of the trim cover over the foam pad.

9. An assembly as set forth in claim 8 wherein said restraint portion includes a
20 flexible fabric having a distal end with said apertures formed within said flexible fabric.

10. An assembly as set forth in claim 9 wherein said restraint portion further includes a bulbous member mounted to said distal end of said flexible fabric.

11. An assembly as set forth in claim 10 wherein said bulbous member is formed
5 of a polymeric material.

12. A seat comprising;

a foam pad having a contoured outer surface;

at least one elongated groove formed within said foam pad below said outer surface;

5 a locking portion secured to said foam pad within said groove;

a trim cover for covering said outer surface of said foam pad; and

a restraint portion secured to said trim cover and adapted to be positioned within said groove when said trim cover overlays said foam pad;

10 said locking portion including at least one clip for selectively engaging said restraint portion to retain said restraint portion to said locking portion during a mounting of said trim cover over said foam pad; and

said locking portion further including at least one base with said base having at least one flexible section such that said locking portion can be manipulated and conform to a configuration of said groove within said foam pad.

15

13. A seat as set forth in claim 12 wherein said locking portion further includes a plurality of bases and a plurality of flexible sections.

14. A seat as set forth in claim 13 wherein said locking portion further includes
20 a plurality of clips with at least one clip disposed on each of said bases.

15. A seat as set forth in claim 14 wherein each of said flexible sections are further defined as a connecting arm with said arm interlinking said bases to form a series of bases and arms.

5 16. A seat as set forth in claim 14 wherein said restraint portion includes a plurality of apertures formed therein to provide a visual alignment when said restraint portion is engaged with plurality of clips for properly aligning the trim cover with the foam pad during a mounting of the trim cover over the foam pad.

10 17. A seat as set forth in claim 12 wherein said groove includes a contoured section.

18. A seat as set forth in claim 17 wherein said contoured section of said groove is substantially parallel to said contoured outer surface of said foam pad.

15 19. A seat as set forth in claim 12 further comprising a mold having a contoured ridge.

20 20. A seat as set forth in claim 19 further including a retaining flange mounted to said contoured ridge and extending upwardly therefrom for engaging said clip of said

locking portion to position said locking portion within said mold and to maintain said clip free of said foam pad.

21. A method of mounting a trim cover to a foam pad of a seat utilizing a fastener assembly having a restraint portion and a locking portion with the locking portion having at least one base and at least one clip wherein the foam pad is formed within a mold having a contoured ridge, said method comprising the steps of:

- 5 securing the restraint portion to the trim cover;
- mounting the locking portion in the mold such that the locking portion conforms to the contoured ridge;
- forming the foam pad within the mold;
- forming at least one groove within the foam pad at the contoured ridge during the
- 10 forming of the foam pad wherein the groove includes at least one contoured section;
- securing the base of the locking portion to the foam pad within at least the contoured section of the groove during the forming of the foam pad;
- overlaying the trim cover over the foam pad with the restraint portion being positioned at least partially within the groove; and
- 15 manipulating the trim cover to interlock the restraint portion with the clip of the locking portion to secure the trim cover to the foam pad.

22. A method as set forth in claim 21 further including the step of removing the foam pad with the locking portion from the mold before overlaying the trim cover over
- 20 the foam pad.

23. A method as set forth in claim 21 further including a retaining flange mounted to said contoured ridge and extending upwardly therefrom and wherein the step of mounting the locking portion is further defined as mounting the locking portion onto the retaining flange such that the locking portion conforms to the contoured ridge.

5

24. A method as set forth in claim 21 wherein the steps of forming at least one groove within the foam pad and securing the base of the locking portion to the foam pad occur simultaneously during the step of forming the foam pad.

10

25. A method as set forth in claim 21 wherein said locking portion includes a plurality of bases each having a corresponding clip with the bases interconnected to each other to form a series of bases and clips having a length substantially equal to a length of the contoured ridge and wherein the step of mounting the locking portion is further defined as mounting the series of bases and clips in the mold to conform to the contoured ridge

15 along a majority of the length of the contoured ridge.

26. A fastener assembly for securing a trim cover to a foam pad of a seat, said fastener assembly comprising;

a restraint portion adapted to be secured to the trim cover;

said restraint portion having a plurality of apertures formed therein; and

5 a locking portion adapted to be secured to the foam pad;

said locking portion including a plurality of spaced clips and at least one base, said spaced clips selectively engaging and retaining said restraint portion, and extending into said apertures to provide a visual alignment feature between said restraint portion and said locking portion for properly aligning the trim cover with the foam pad during a mounting
10 of the trim cover over the foam pad.

27. An assembly as set forth in claim 26 wherein said restraint portion includes a flexible fabric having a distal end with said apertures formed within said flexible fabric.

15 28. An assembly as set forth in claim 27 wherein said restraint portion further includes a bulbous member mounted to said distal end of said flexible fabric.

29. An assembly as set forth in claim 28 wherein said bulbous member is formed of a polymeric material.

20

30. An assembly as set forth in claim 26 wherein said locking portion further includes a plurality of bases with at least one of said clips mounted to each of said bases.

31. An assembly as set forth in claim 30 further including a plurality of flexible
5 sections separating said bases.

32. An assembly as set forth in claim 31 wherein each of said flexible sections are further defined as a connecting arm with said arm interlinking said bases to form a series of bases and arms.
10

33. An assembly as set forth in claim 32 wherein said series of bases and arms include alternating bases and arms.

34. An assembly as set forth in claim 26 wherein each of said clips include
15 opposing legs with said legs having a barb, said barbs of said clips at least partially extending into said apertures of said restraint portion during the mounting of the trim cover over the foam pad.

FIG - 1

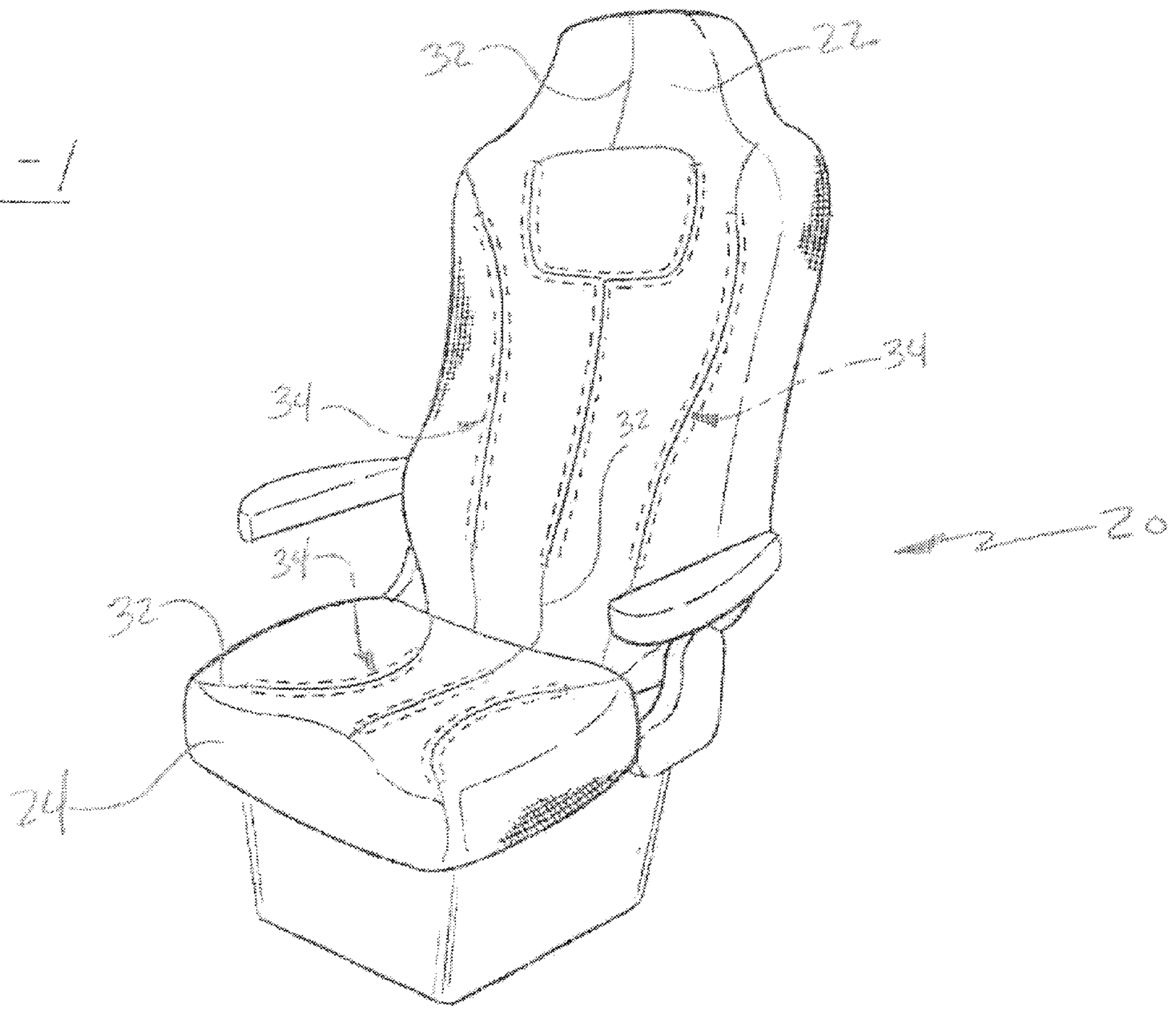
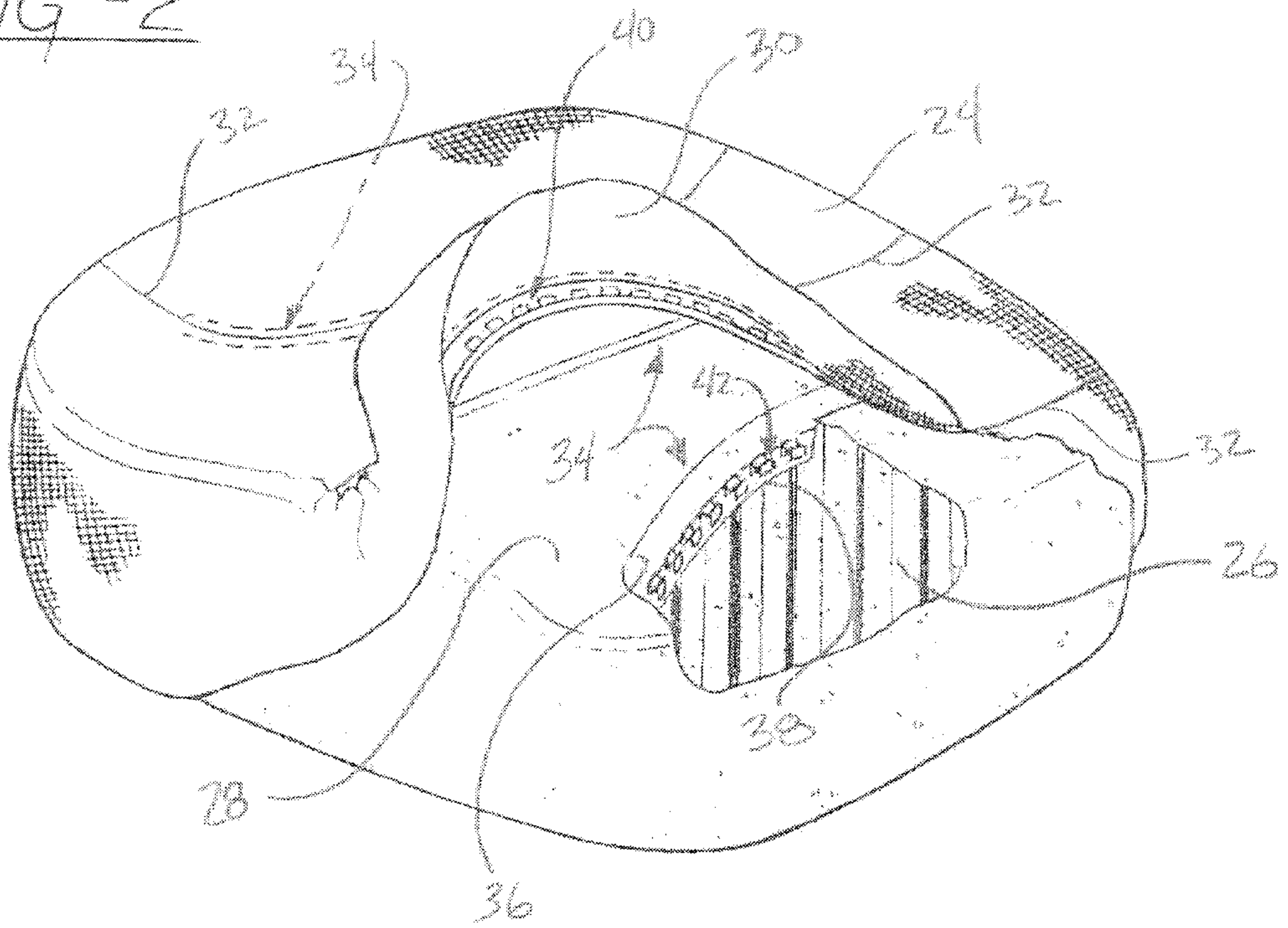

FIG - 2



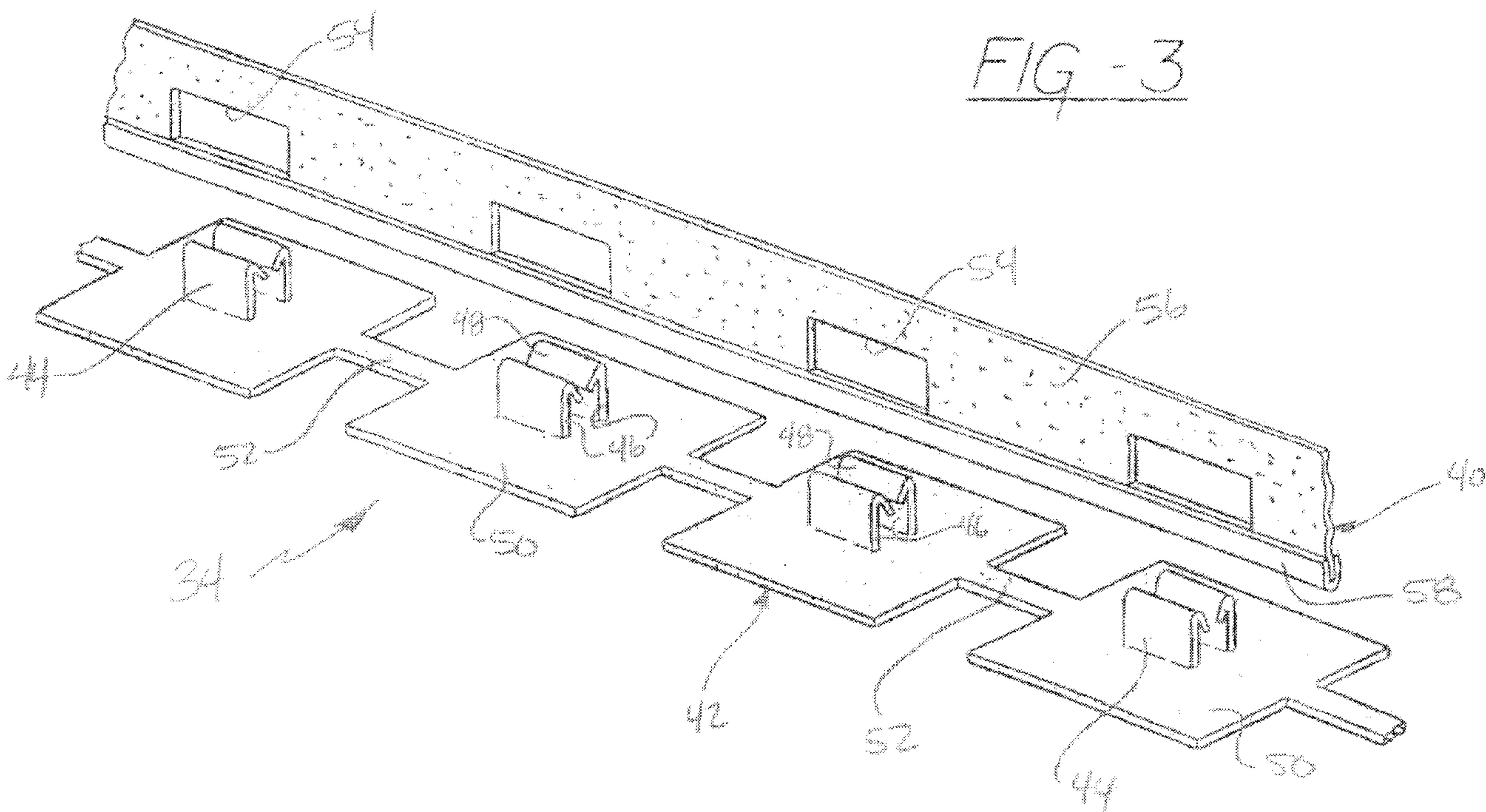

FIG - 4

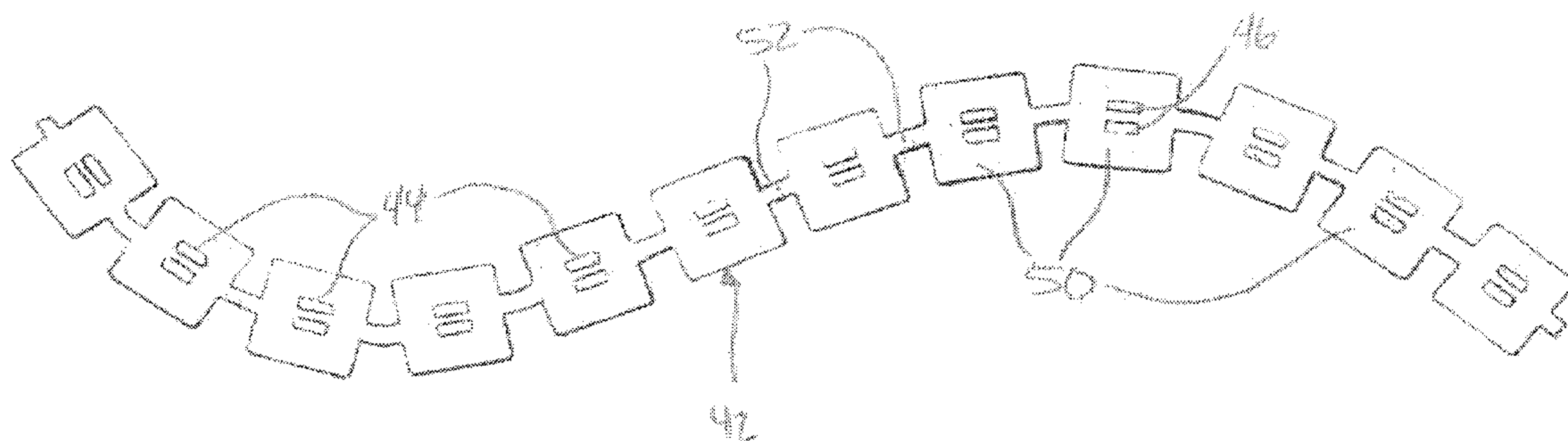
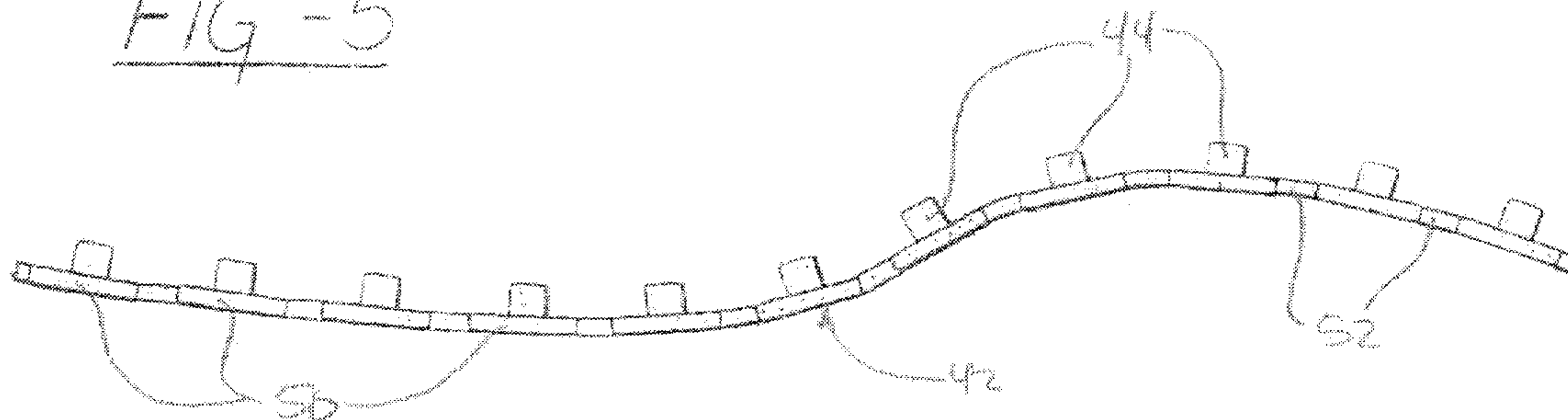

FIG - 5



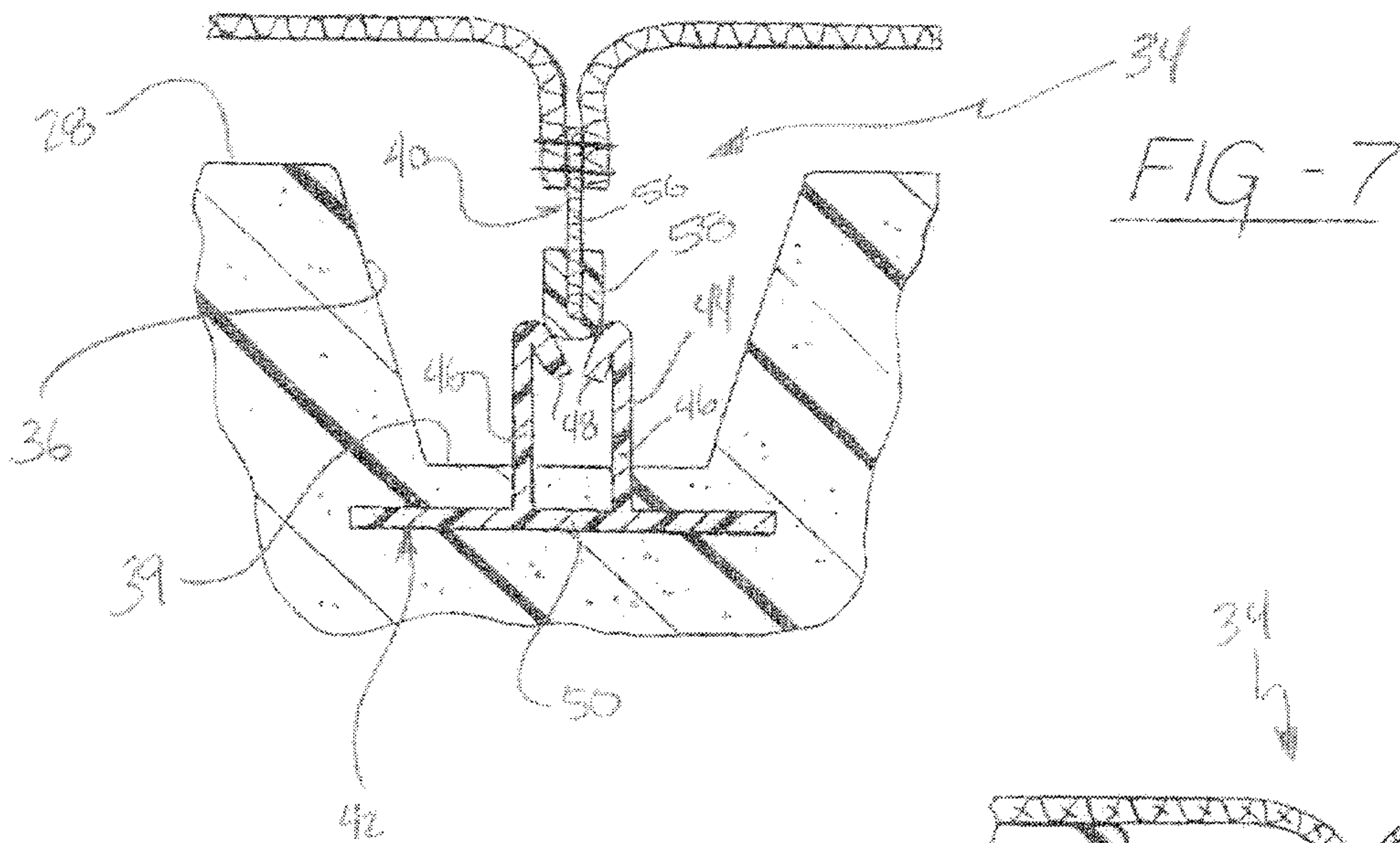
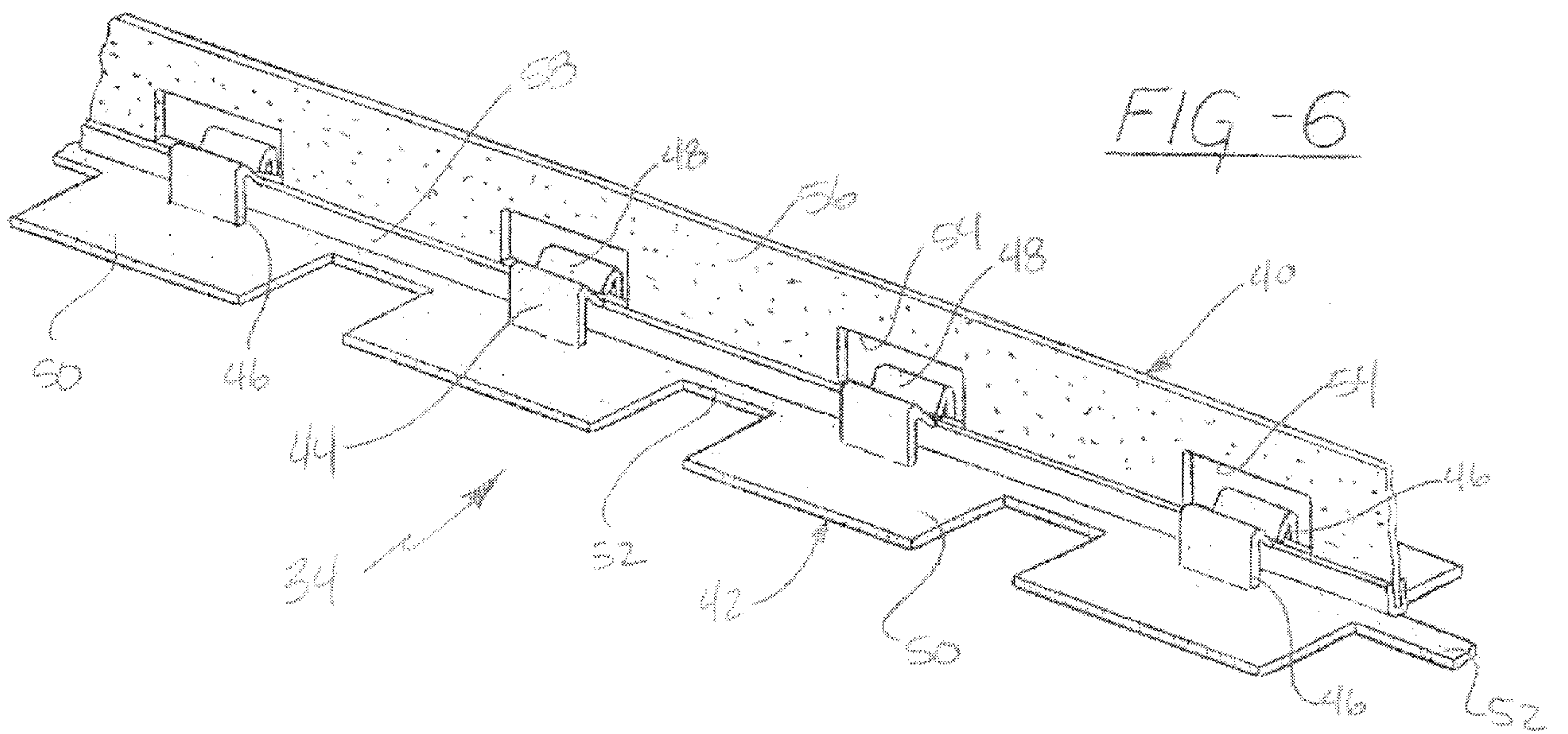
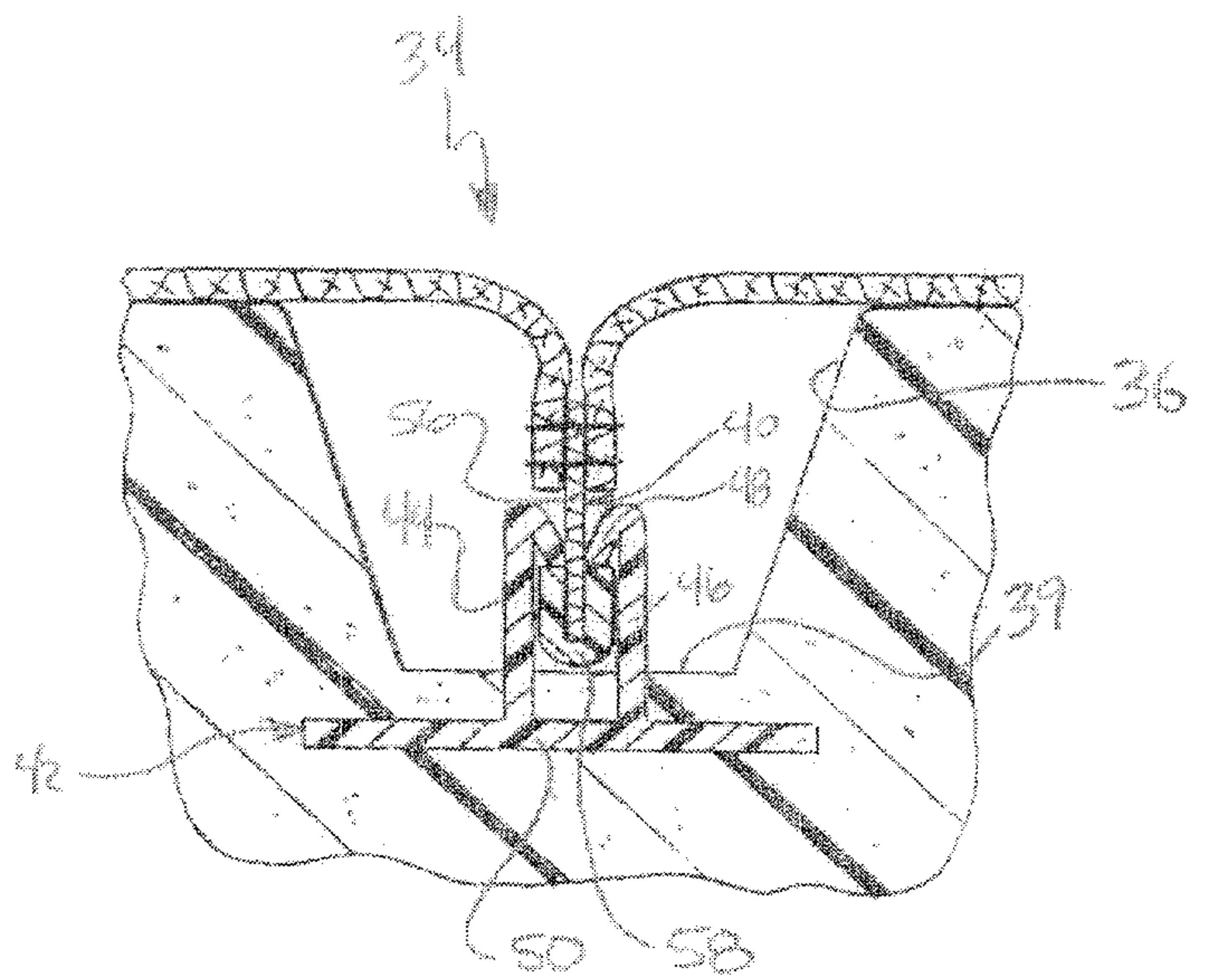

FIG - 8



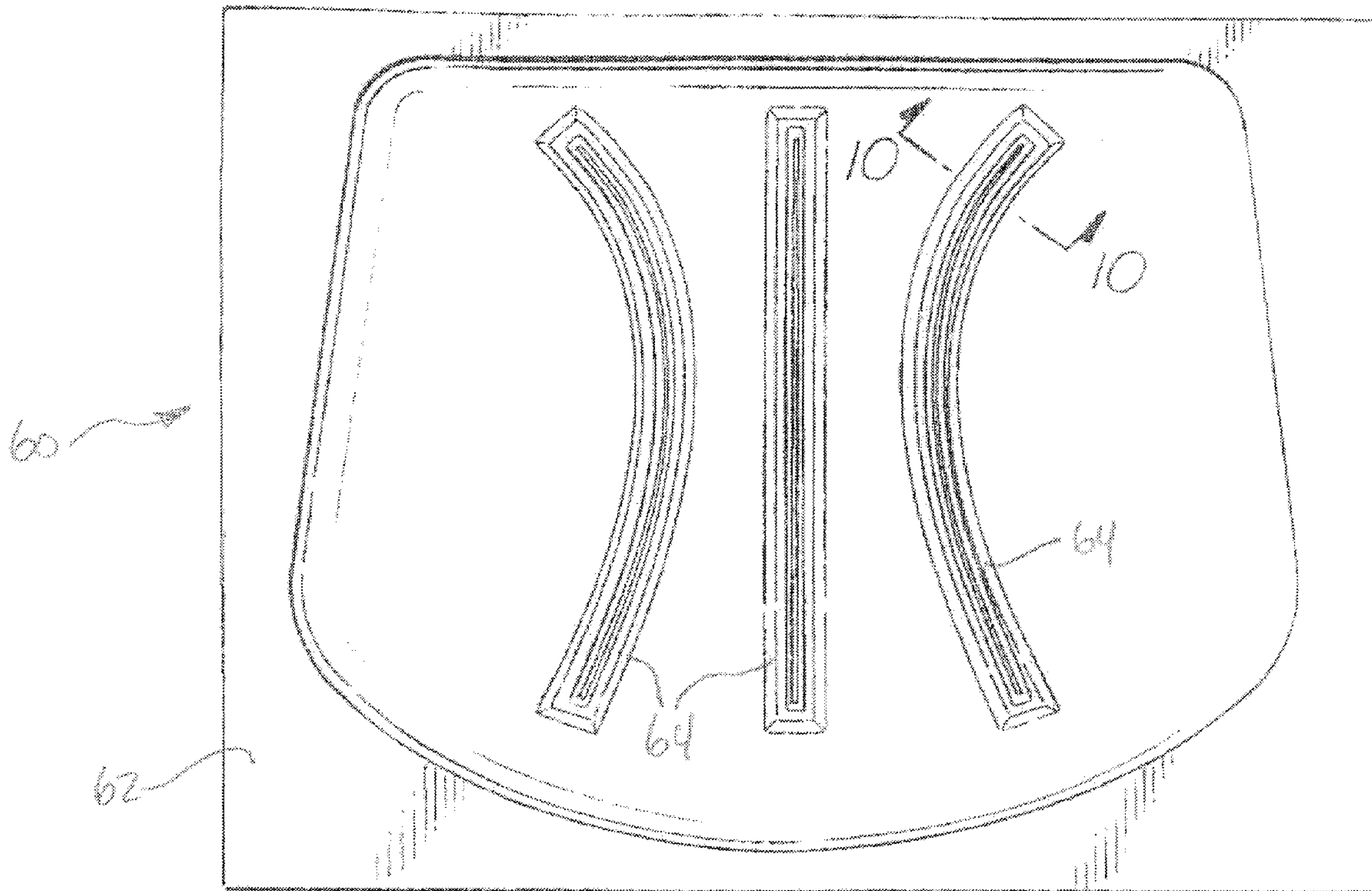

FIG - 9

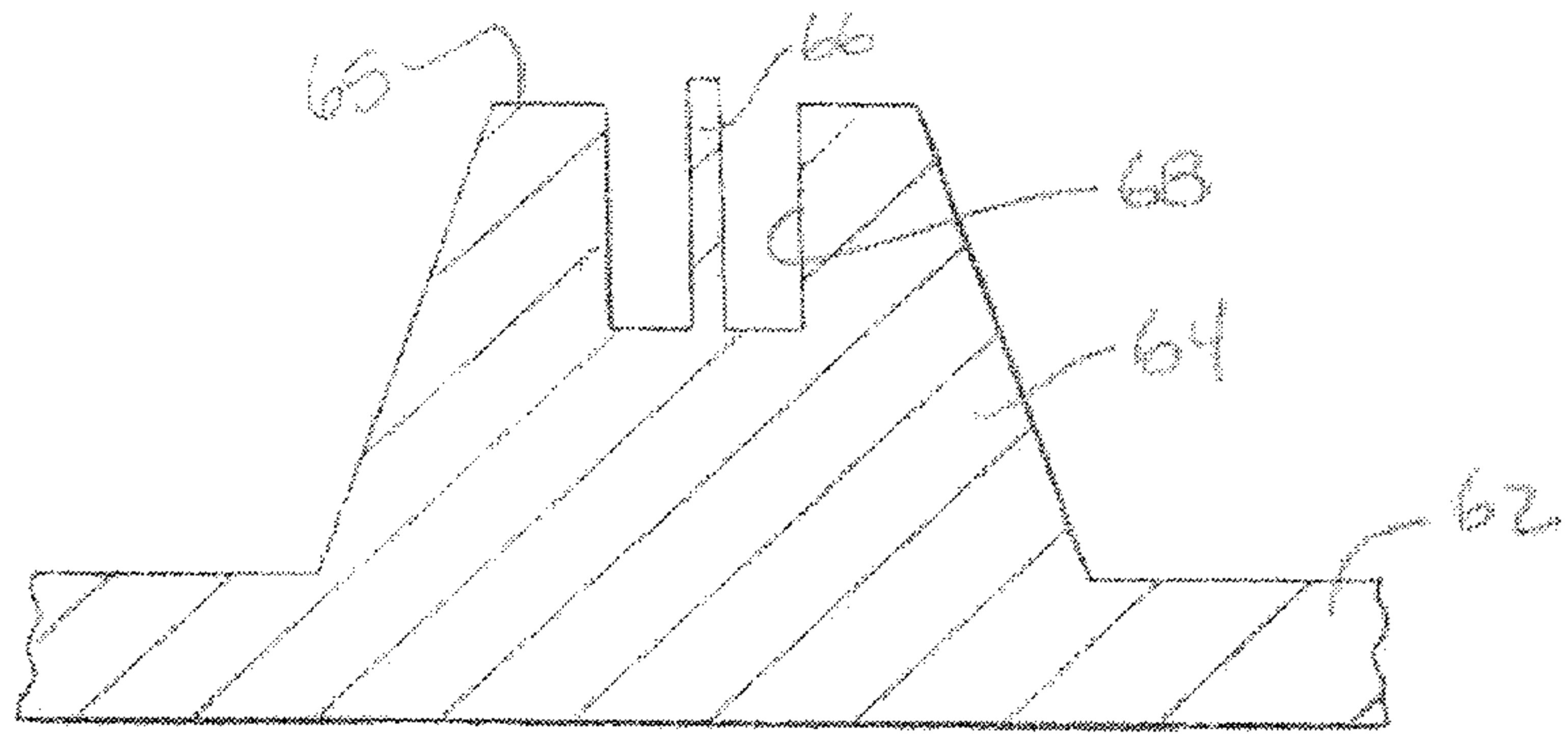

FIG - 10

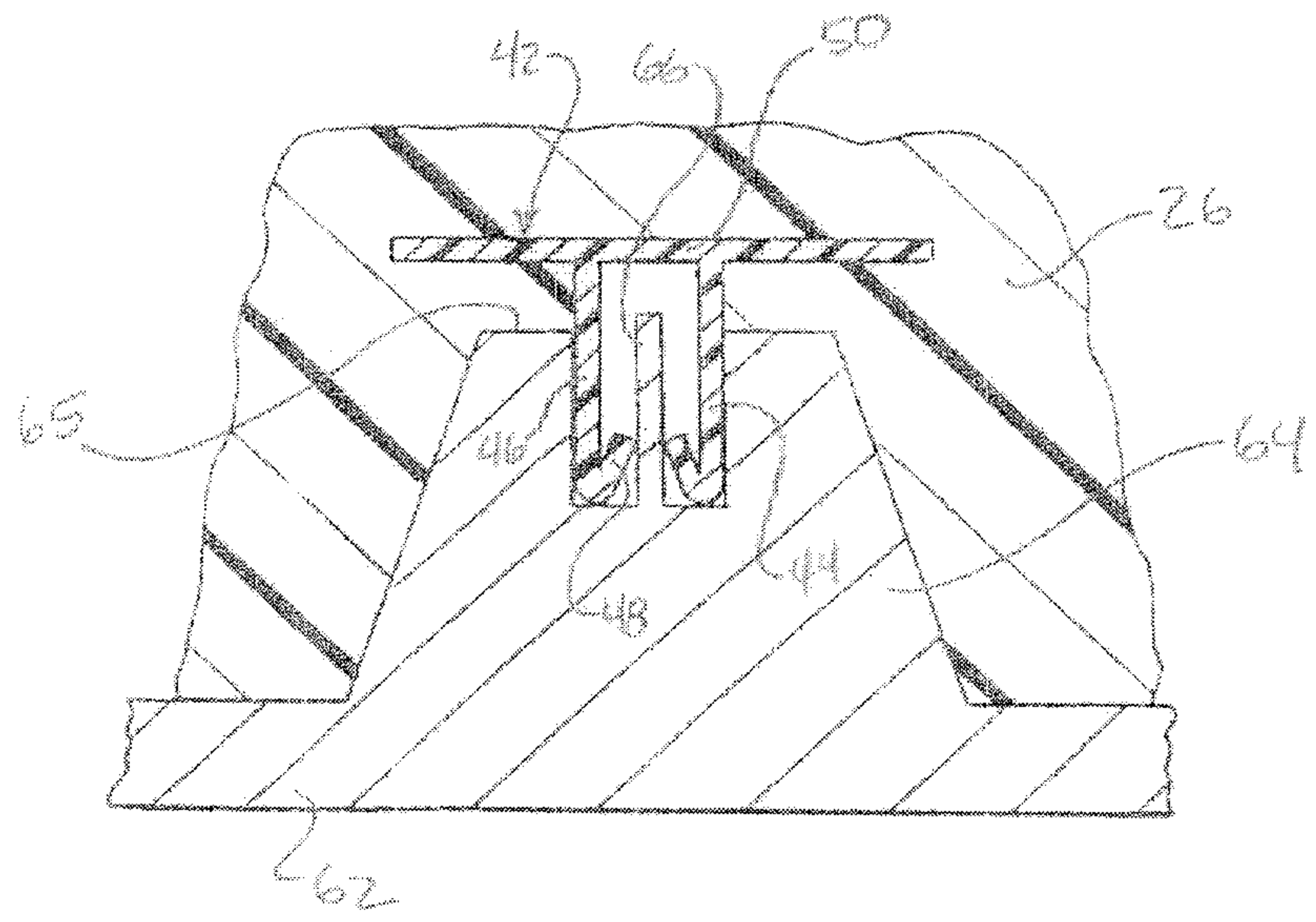

FIG - 11

