

(19)  
(12)

(KR)  
(B1)

(51) 。 Int. Cl.<sup>7</sup>  
B62D 33/02

(45)  
(11)  
(24)

2004 02 14  
10-0418747  
2004 02 03

(21) 10-2000-0076628  
(22) 2000 12 14

(65)  
(43)

10-2002-0046434  
2002 06 21

(73) 231

(72) 1 8-17

(74)  
:

(54)

가

, (10) , (20) (20) (40) (10) ; (22)가 (30) ; (20) ; (10) (21) , (10) 가 가

2a

, , SUT,

1 ,  
2a 가 ,  
2b 2a A-A' ,  
3a 가  
3b 3a B-B' ,

4 5  
< >  
10 : 20 :  
21 : 22 :  
30 : 40 :

(sports utility truck; SUT)

1  
(1) (1) (2)가  
(2)  
가 SUT 가

, SUT 가

가 ; ;

2a 3b 2b 2a A-A' 2a 가  
3a 3a B-B' 3a 가

2a (10) (22)가 (22)가 (21)가 가  
(20)가

(10) (10) (20) (30)가 (30)가  
(10) (11) (20) (20)가 가 가 (20)가 (20)가 (10)가  
(20)가 (11)

가 (10) (30) (20)가 (10)  
(40) (40)가 (22) (22a) (41) (41) 가  
(21) (41) (41) (42) 가  
(42)

2a (21) 2b 2a , 가 (F) (41)가 (22) 가 (21) (20) 가 (40) 가 (42) (30) 90° (22)가 (22) 3a 3b (22a) (20) (10) (22) (22a) (20) (40) 90° (41)가 (22) (20)가 (10) (10)

가 가 가 가 가 SUT

(57)

1.

; ; 가 ; 가 가 ; 가 가 ; 가 가

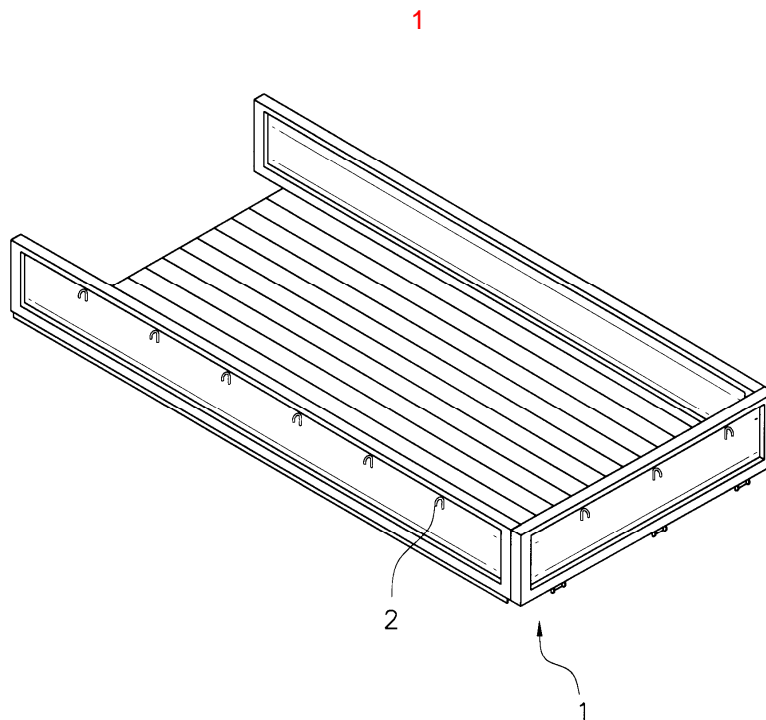

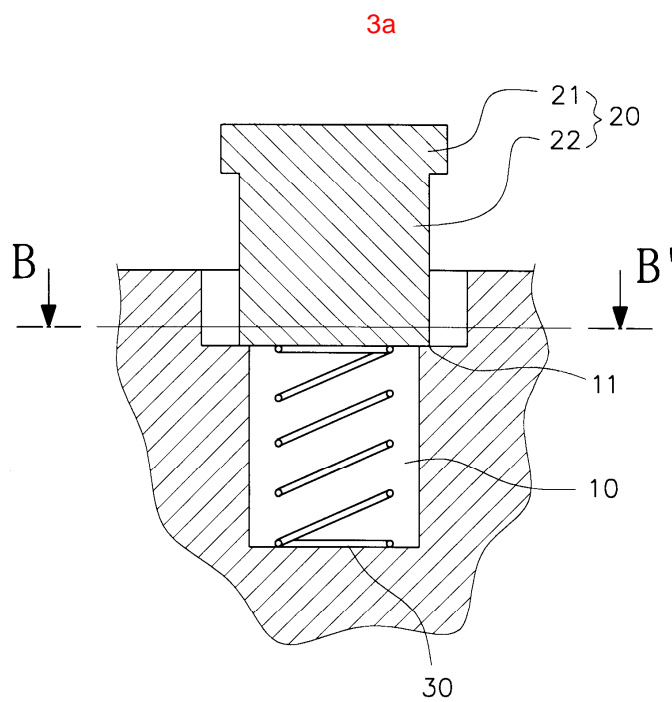
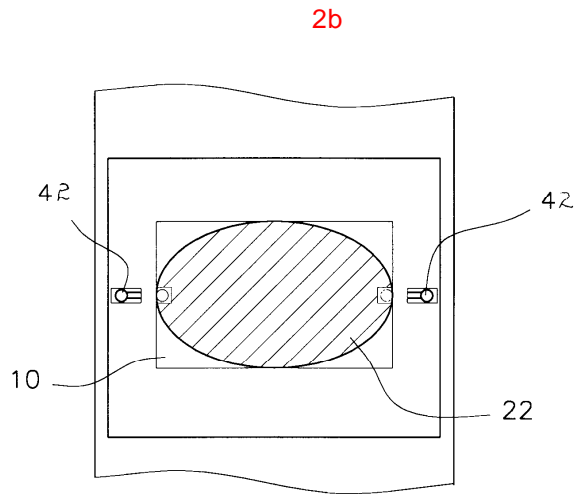
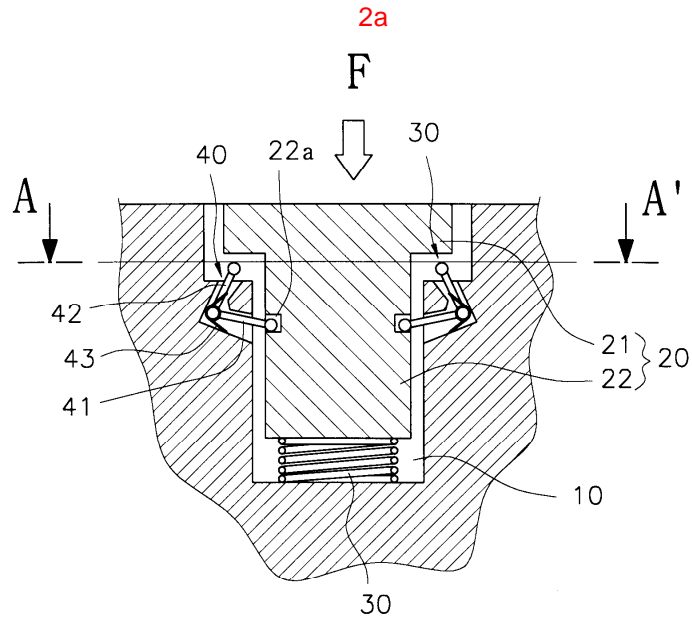

3b

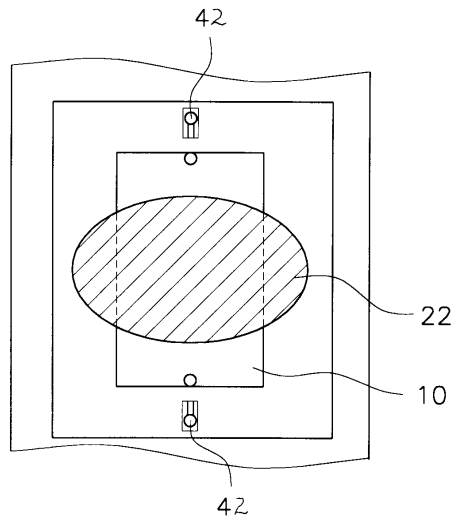

4

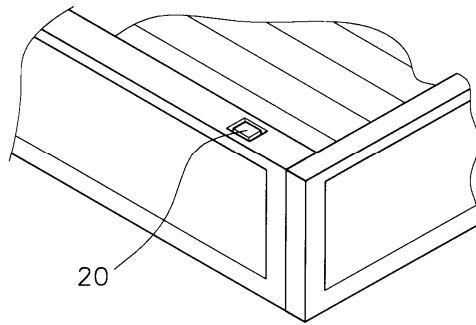

5

