



- (51) International Patent Classification:
G06F 1/16 (2006.01) H04B 1/38 (2006.01)
H04N 5/225 (2006.01)
- (21) International Application Number:
PCT/US2013/029577
- (22) International Filing Date:
7 March 2013 (07.03.2013)
- (25) Filing Language: English
- (26) Publication Language: English
- (30) Priority Data:
61/607,786 7 March 2012 (07.03.2012) US
- (71) Applicant: CAMCADDY, LLC [US/US]; 8595 Pelham Road, Greenville, South Carolina 29615 (US).

- (72) Inventors: SILVA, William A.; 366 Beechwood Drive, Greer, South Carolina 29651 (US). MANESS, Michael H.; 114 Mallard Street, Greenville, South Carolina 29601 (US). CORLEY, Ben S., Jr.; 9 Cape Charles Drive, Greenville, South Carolina 29615 (US).
- (74) Agents: HARDAWAY, John B., III et al.; NEXSEN PRUET LLC, 55 East Camperdown Way, Greenville, South Carolina 29601 (US).
- (81) Designated States (unless otherwise indicated, for every kind of national protection available): AE, AG, AL, AM, AO, AT, AU, AZ, BA, BB, BG, BH, BN, BR, BW, BY, BZ, CA, CH, CL, CN, CO, CR, CU, CZ, DE, DK, DM, DO, DZ, EC, EE, EG, ES, FI, GB, GD, GE, GH, GM, GT, HN, HR, HU, ID, IL, IN, IS, JP, KE, KG, KM, KN, KP, KR, KZ, LA, LC, LK, LR, LS, LT, LU, LY, MA, MD, ME, MG, MK, MN, MW, MX, MY, MZ, NA, NG, NI, NO, NZ, OM, PA, PE, PG, PH, PL, PT, QA, RO, RS, RU,

[Continued on next page]

(54) Title: METHOD AND DEVICE FOR ELEVATING MOBILE DEVICE

(57) Abstract: A method and device for holding an electronic device, such as a suitably-equipped cellular phone, having a video recording feature, or simply a camera, at a desired elevation for filming or photographing. The device includes a frame for holding the electronic device and a vertical support serving as a monopod, such as a golf alignment stick. The frame may be a two-part adjustable frame comprising two interlocking, opposing, L-shaped elements.

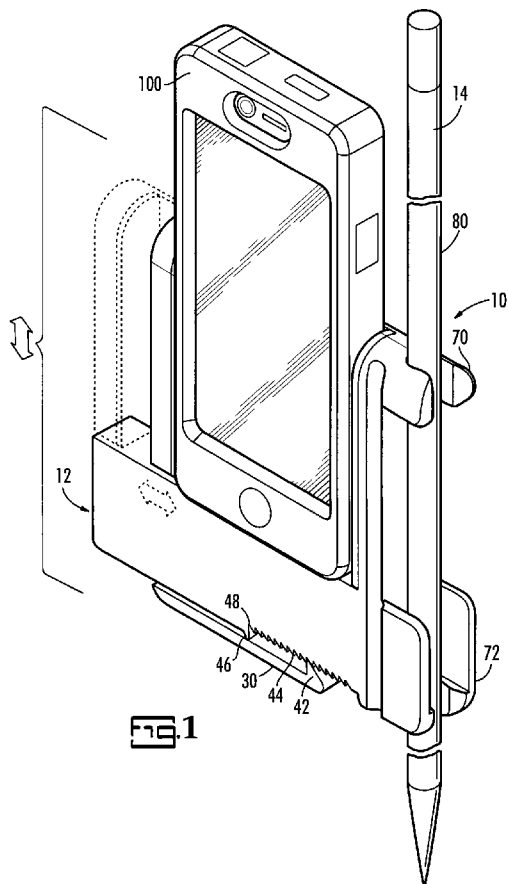

WO 2013/134494 A1



RW, SC, SD, SE, SG, SK, SL, SM, ST, SV, SY, TH, TJ, TM, TN, TR, TT, TZ, UA, UG, US, UZ, VC, VN, ZA, ZM, ZW.

EE, ES, FI, FR, GB, GR, HR, HU, IE, IS, IT, LT, LU, LV, MC, MK, MT, NL, NO, PL, PT, RO, RS, SE, SI, SK, SM, TR), OAPI (BF, BJ, CF, CG, CI, CM, GA, GN, GQ, GW, ML, MR, NE, SN, TD, TG).

(84) Designated States (*unless otherwise indicated, for every kind of regional protection available*): ARIPO (BW, GH, GM, KE, LR, LS, MW, MZ, NA, RW, SD, SL, SZ, TZ, UG, ZM, ZW), Eurasian (AM, AZ, BY, KG, KZ, RU, TJ, TM), European (AL, AT, BE, BG, CH, CY, CZ, DE, DK,

Published:

— *with international search report (Art. 21(3))*

TITLE**METHOD AND DEVICE FOR ELEVATING MOBILE DEVICE****CROSS REFERENCE TO RELATED APPLICATIONS:**

5 [0001] The present application claims the benefit of priority of U.S. Provisional Application No. 61/607786, filed on March 7, 2012, which is incorporated herein in its entirety.

BACKGROUND OF THE INVENTION:

[0002] The present invention relates generally to supports for elevating electronic mobile devices, including video recorders.

10 [0003] Sporting and recreational activities are often filmed or recorded with various devices. Unless one has the assistance of another person in the recording process, devices must be employed to fix and elevate a camera to the proper location to capture the scene or shot.

15 [0004] While various devices may serve the purpose of propping a video recorder at an appropriate distance and location from what is being filmed, these oftentimes can be cumbersome, heavy or inconvenient for the user. Thus, these devices are typically only used when there is a special need or a prescheduled event requiring filming. Having a more compact and convenient device that provides for filming, and particularly, filming in a spontaneous manner is desirable.

20 [0005] Accordingly, there is a need for a convenient support to capture video footage from a desired location.

SUMMARY OF THE INVENTION:

25 [0006] The following presents a simplified summary of the invention in order to provide a basic understanding of some aspects of the invention. This summary is not an extensive overview of the invention. It is not intended to identify key or critical elements of the invention or to delineate the scope of the invention; its sole purpose is to present concepts of the invention in a simplified form as a prelude to the more detailed description that is subsequently presented.

30 [0007] The present invention includes a method and device for holding an electronic device, such as a suitably-equipped cellular phone, having a video recording feature, or simply a camera, at a desired elevation for filming or photographing.

35 [0008] The device includes a frame for holding the electronic device and a vertical support serving as a monopod, such as a golf alignment stick. The frame may be a two-part adjustable frame comprising two interlocking, opposing, L-shaped elements. In such an embodiment, each element has a vertical portion and a horizontal portion. The horizontal portions of the two elements engage each other and lock.

[0009] In operation, the first element of the frame moves with respect to the second element of the frame, and, as it moves, changes the separation distance between the vertical portions of the two elements to a desired separation distance that accommodates the width of the particular video recorder to be used. Adjustment of the separation distance is accomplished by engaging a lock system that may include a lever on one of the two frame elements that is holds the other of the two frame elements at a desired distance from the first element.

[0010] The elevation of the frame may be adjusted through the use of a vertical support that can engage one of the two frame elements. In one embodiment, one frame element includes clips to snap onto the vertical support. The clips and the vertical support are complementary in shape so as to form a snug, snap fit. As used herein, "snap fit" can refer to any friction, force, or swage fit that is achieved by pressing or forcing a male member into a corresponding female member and that does not permanently connect or attach the members.

[0011] The present invention further includes a method for holding and elevating an electronic device for the purpose of recording an event. The method may comprise the steps of: 1) providing a holding frame having a first and second element that interlock; 2) providing a recording device having a width; 3) adjusting the holding frame so that the distance between the first and second elements is greater than the width of the electronic device; 4) placing the recording device between the first and second elements; 5) adjusting the holding frame so that the distance between the first and second elements is such that the recording device is held firmly in place; 6) placing a vertical support in the ground; and 6) connecting the holding frame to a vertical support at a desired elevation.

[0012] A feature of the present invention is the use of an adjustable frame, which effectively holds a recording device and that is also stream lined to avoid obscuring the recording, and light weight for convenient storage and transport by the user.

[0013] Another feature of the present invention is the use of a frame that cooperates with a vertical support that serves as a monopod to adjust the frame at a desired height.

[0014] Other features and their advantages will be readily apparent to those skilled in the arts, techniques and equipment relevant to the present invention from a careful reading of the Detailed Description of Preferred Embodiments, accompanied by the following drawings.

BRIEF DESCRIPTION OF THE DRAWINGS:

[0015] FIG. 1 includes a perspective view of an embodiment of the holding device according to the present invention;

[0016] FIG. 2A includes a perspective view of an embodiment of the holding device according to the present invention;

[0017] FIG. 2B includes a perspective view of an embodiment of the holding device according to the present invention;

5 [0018] FIG. 3 includes a perspective view of an embodiment of the holding device according to the present invention; and

[0019] FIG. 4 includes a side elevation view of an embodiment of the holding device according to the present invention.

DETAILED DISCLOSURE OF THE PREFERRED EMBODIMENT:

10 [0020] The present invention includes a method and device for holding an electronic device, such as a suitably-equipped cellular phone, having a video recording feature, or simply a camera, at a desired elevation for filming or photographing.

[0021] Referring now to the figures, FIGS. 1-4 depict an embodiment of the present invention. The device 10 includes a frame 12 for holding an electronic device
15 100 and a vertical support 14 serving as a monopod.

[0022] The electronic device 100 may be any suitably equipped cellular telephone, or so-called smart phone, or other device with a recording feature that is generally rectangular or square in shape, or that generally has a width and a length, even if possessing rounded edges. Such devices commonly have dimensions ranging from
20 about 100 to 150 mm by about 50 to 70 mm by about 8 to 13 mm in length, width and depth, with other dimensions possible.

[0023] The frame 12 may be a two-part adjustable frame comprising a first and a second frame element, 16 and 18, that are interlocking, opposing, and generally L-shaped. In such an embodiment, each element, 16 and 18, has a vertical portion, 20 and 22, and a horizontal portion, 24 and 26. The horizontal portions, 24 and 26, of the
25 two elements engage each other and lock. Additionally, the horizontal portions, 24 and 26, are slidable with respect to each other.

[0024] In one embodiment shown best in FIG. 4, the horizontal portion 24 of the first frame element 16 may comprise a male sliding member 32 that is coupled to and
30 received by a female sliding member 34. These sliding members, 32 and 34, complement each other in shape and dimension, and allow for movement between frame elements 16 and 18 along the horizontal axis of these elements, while still maintaining them engaged with respect to other axes. For example, the male sliding member 32 may have T-shaped in cross-section, whereas the female sliding member 34 may have a
35 corresponding T-shaped groove that is dimensioned to receive the male sliding member 32 in a manner that allows for lateral movement, but that limits or prevents movement in other directions.

[0025] In operation, the first element 16 of the frame moves with respect to the second element 18 of the frame, and, as it moves, changes the separation distance between the vertical portions, 20 and 22, of the two elements to a desired separation distance that accommodates the width of the particular video recorder 100 to be used.

5 [0026] Adjustment of the separation distance may be accomplished by pressing on a resilient lever 30 integral to or monolithic with the horizontal portion 24 of the first, and slidable, element 16 of the two-part frame, and then sliding the horizontal portion 24 with respect to the second, immovable, horizontal portion 26 of the two-part frame 12. The lever 30 on the first element 24 may be engaged by a tab 40 connected to
10 and extending out from the lever 30. The tab 40 is dimensioned for convenient pressing of the lever 30. For example, the tab 40 may have a surface that is dimensioned to support the end of a human finger for the pressing of the lever.

[0027] Furthermore, the lever 30 may carry a tooth 42 that engages, when it is not being pressed, one of a series of parallel grooves 44, carried on the second element
15 18 and thereby secures the two elements, 16 and 18, in position until the user next presses the lever 30 to disengage the tooth 42 from the particular groove it has been in so that the first element 16 can be moved with respect to the second element 18 and thereby change the separation distance between the vertical portions, 20 and 22, of the two elements.

20 [0028] In one embodiment, the series of parallel grooves 44 includes a first groove 48 having a first wedge-like protrusion 46 that extends out from the bottom surface of the horizontal portion 26 of the second frame element 18, and is generally longer than the adjacent protrusions formed by the series of parallel grooves 44. The wedge 46 is generally V-shaped and serves to engage and stop the lever tooth 42 from
25 moving beyond it unless the lever 30 is forced below and around the wedge 46 by the user.

[0029] The vertical portions, 20 and 24, are sized and shaped to both support the video recorder and yet also to allow the lens on the video recorder to not be obstructed when the recorder is in position on the device. For example, many so-called
30 smart phones have recording capabilities that includes a lens near the upper end of the back of the phone. To accommodate these types of phones, the vertical members, 20 and 24, of the present device 10 may provide lateral support from two sides for the smart phone 100, but may be shorter than the smart phone so that the lens is above them.

[0030] Alternatively, if the smart phone 100 includes a camera that is not
35 affected by the height of the vertical elements, 20 and 24, these elements may be at a height that provides sufficient lateral support and still enables the user to easily grasp the sides of the smart phone 100 for installation and removal from the frame 12.

[0031] Additionally, each of the vertical elements, 20 and 24, may further include a rear wall portion, 52 and 54, that is about perpendicular to a side wall portion, 56 and 58. These walls form corners that receive the corresponding corners of the smart phone device 100, and provide for rear support in addition to lateral support.

5 [0032] The two elements may also include resilient strips, 60 and 62, on their vertical members, 20 and 22, where they engage the video recorder 100 to protect the latter from scratches and from inadvertently pressing buttons that may be on the recorder's sides. The materials for the strips, 60 and 62, may include foamed materials, such as foamed rubber, that are sponge-like and non-abrasive to materials typically
10 employed in the construction of video recording devices, such as smart phones.

[0033] The vertical support 14 may be engageable by the second element 18 of two-part frame 12. In one embodiment, the second element 18 of may have integrally formed, resilient clips, 70 and 72, to snap onto a thin, cylindrical support 80, such as an alignment stick as is often used by golfers to obtain a sense of the variations in the
15 surface of a golfing green. Alternatively, a single clip may be used, or more than two clips may be used. In the embodiment shown in the figures, the use of a first upper clip 70 and a second lower clip 72 may facilitate the insertion and removal of the alignment stick 80 by providing open space there between.

[0034] The alignment stick 80 can be pressed into the ground at a depth
20 sufficient to hold it vertically, and then the present device 10, with a video recorder in position between the first and second elements, 16 and 18, is snapped onto the alignment stick 80 at a suitable elevation. The video recorder is then in position to capture images without being held, the alignment stick 40 serving essentially as a monopod.

25 [0035] The shape and dimension of the clips 70 and 72 complement the shape and dimension of the vertical support 14. For example, if the vertical support is rod-like, such as a golf alignment stick, the clips on the frame include a rounded cavity 82 to receive the stick and to form a snug fit. For example, the clips 70 and 72 may resemble a horse-shoe design having an open side and a rounded closed side.

30 [0036] Optionally, the edges at the insertion area or open side of the clips, 70 and 72, may be beveled to facilitate the insertion and snapping together with the vertical support 14. Additionally, the vertical portion 22 of the second element 18 may include a vertical groove 90 on either or both sides of the vertical portion 22 and adjacent to the clips 70 and 72. The groove 90 may extend the length of the vertical portion 22 and can
35 serve to facilitate the snapping of the vertical support 14 by increasing the flexibility or resilience of the clips 70 and 72.

[0037] Another option for the holding device includes a gripping mound 92, shown in FIGS. 3-4, on the horizontal portion 24 of the first element 16, which may facilitate the adjustment of the frame element with relation to the other frame element 18. Alternatively, the surface of the holding device can be relatively flat and smooth.

5 [0038] The materials employed for the two-part frame may include any suitable material for this type of construction, include a plastic material. Preferably, the material is sturdy, yet light-weight and resilient enough to enable the pressing and clipping actions required to operate the device. Additionally, the features described as forming part of one or the other of the two frame elements may be monolithic, or form part
10 of a single piece, respectively.

[0039] The present invention further includes a method for holding and elevating an electronic device for the purpose of recording an event. The method may comprise the steps of: 1) providing a holding frame having a first and second element that interlock; 2) providing an electronic recording device having a width; 3) adjusting the
15 holding frame so that the distance between the first and second elements is greater than the width of the recording device; 4) placing the recording device between the first and second elements; 5) adjusting the holding frame so that the distance between the first and second elements is such that the recording device is held firmly in place; 6) placing a vertical support in the ground; and 6) connecting the holding frame to a vertical support at
20 a desired elevation.

[0040] Those skilled in the relevant arts will appreciate from the foregoing description of preferred embodiments that substitutions and modification can be made without departing from the spirit and scope of the invention which is defined by the appended claims.

25

WHAT IS CLAIMED IS:

1. A device for holding a video recorder at a desired elevation, comprising:

a holding frame having a first element that interlocks with a second element, wherein each of said first and second elements includes a vertical portion and a horizontal portion, and wherein said first element is movable with respect to said second element such that the separation distance between said vertical portions of said first and second elements accommodates the width of the video recorder being used; and

a vertical support for elevating said holding frame, wherein said holding frame and said vertical support are releasably connected.

2. The device as recited in claim 1, wherein each of said first and second elements are L-shaped.

3. The device as recited in claim 1, wherein said horizontal portion of said first element includes a lever carrying a tooth.

4. The device as recited in claim 3, wherein said horizontal portion of said second element carries a series of parallel grooves, and wherein said tooth engages one of said series of parallel grooves when said lever is not being pressed.

5. The device as recited in claim 4, wherein said series of parallel grooves includes a first wedge that extends out from the bottom surface of said horizontal portion of said second element, and wherein said first wedge restricts the lateral movement of said tooth.

6. The device as recited in claim 3, wherein said lever is connected to a tab that extends out from said lever, and wherein said tab has a surface area that is dimensioned to support the end of a human finger for the pressing of said lever.

7. The device as recited in claim 1, wherein said vertical portion of said second element includes a first resilient clip.

8. The device as recited in claim 7, wherein said vertical support is an alignment stick that is dimensioned for insertion into and snap fit with said first resilient clip.

9. The device as recited in claim 7, wherein said vertical portion of said second element includes a second resilient clip, said alignment stick being dimensioned for insertion into and snap fit with said second resilient clip.

10. The device as recited in claim 9, wherein said first resilient clip and said second resilient clip are spaced sufficiently apart to allow for grasping of said vertical support.

11. The device as recited in claim 9, wherein each of said first and second resilient clips includes beveled edges.

12. The device as recited in claim 9, wherein said vertical portion of said second element includes a first vertical groove adjacent to said first and second clips.

13. The device as recited in claim 12, wherein said vertical portion of said second element includes a second vertical groove on an opposing side of said vertical portion and adjacent to said first and second clips.

5 14. The device as recited in claim 1, wherein each of said vertical portions of said first and second elements includes a side wall that is about perpendicular to a rear wall.

15. The device as recited in claim 14, wherein each of said side walls includes a resilient strip.

10 16. The device as recited in claim 1, wherein said horizontal portion of said first element is coupled to said horizontal portion of said second element through corresponding male and female members, respectively.

17. A device for holding a video recorder at a desired elevation, comprising:
a holding frame having a first element that interlocks with a second element through a lever system, wherein each of said first and second elements includes a vertical portion and a horizontal portion, and wherein said first element is movable with
15 respect to said second element such that the separation distance between said vertical portions of said first and second elements accommodates the width of the video recorder being used.

18. The device as recited in claim 16, further comprising a vertical support, wherein said holding frame and said vertical support are releasably connected by a snap
20 fit, and wherein said lever system comprises:

a lever carrying a tooth that is integral with said horizontal portion of said first element; and

a series of parallel grooves integral with said horizontal portion of said second element, wherein said tooth engages one of said series of parallel grooves when said
25 lever is not being pressed.

19. A method for holding a video recorder at a desired elevation, comprising the steps of:

providing a holding frame having a first element interlocked with a second element, wherein each of said first and second elements includes a vertical portion and a
30 horizontal portion, wherein said first element is movable with respect to said second element such that the separation distance between said vertical portions of said first and second elements can be adjusted; and wherein one of said first and second elements have a clip;

providing a video recorder having a width;

35 placing said video recorder between said vertical portions;

adjusting the separation distance between said vertical portions, wherein the separation distances provides for a secure hold on said video recorder;

providing a vertical support;
fixing said vertical support into the ground; and
snapping said holding frame onto said vertical support at a desired elevation.

20. The method as recited in claim 19, wherein said horizontal portion of said first
5 element includes an integral lever carrying a tooth, wherein said second element has a
series of parallel grooves that are engageable by said tooth, and wherein said adjusting
of the separation distance between said vertical portions is done by pressing on said
lever, moving said first element laterally along said series of parallel grooves, and
engaging said tooth of said lever with one of said series of parallel grooves located at the
10 desired separation distance.

15

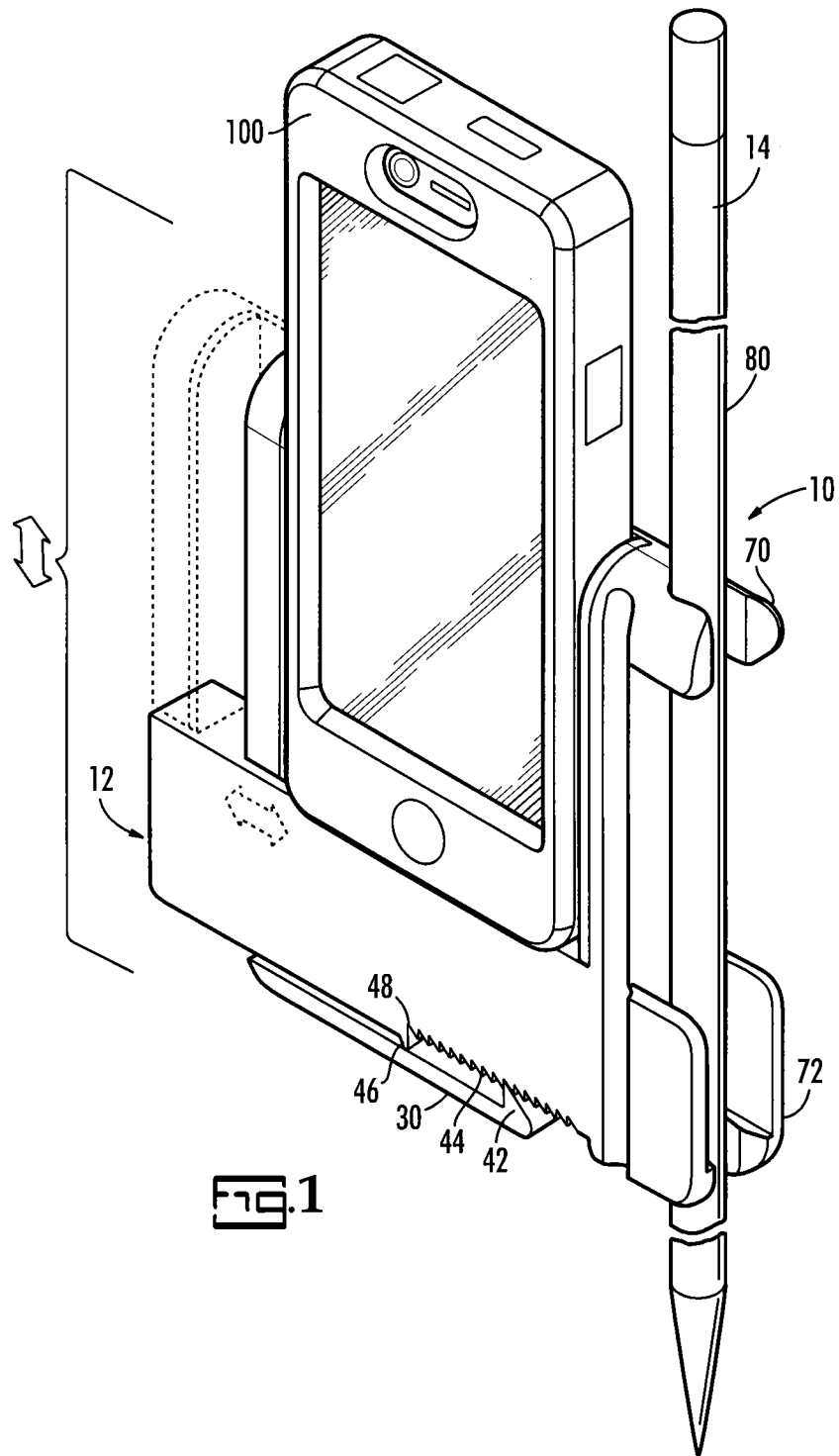

FIG. 1

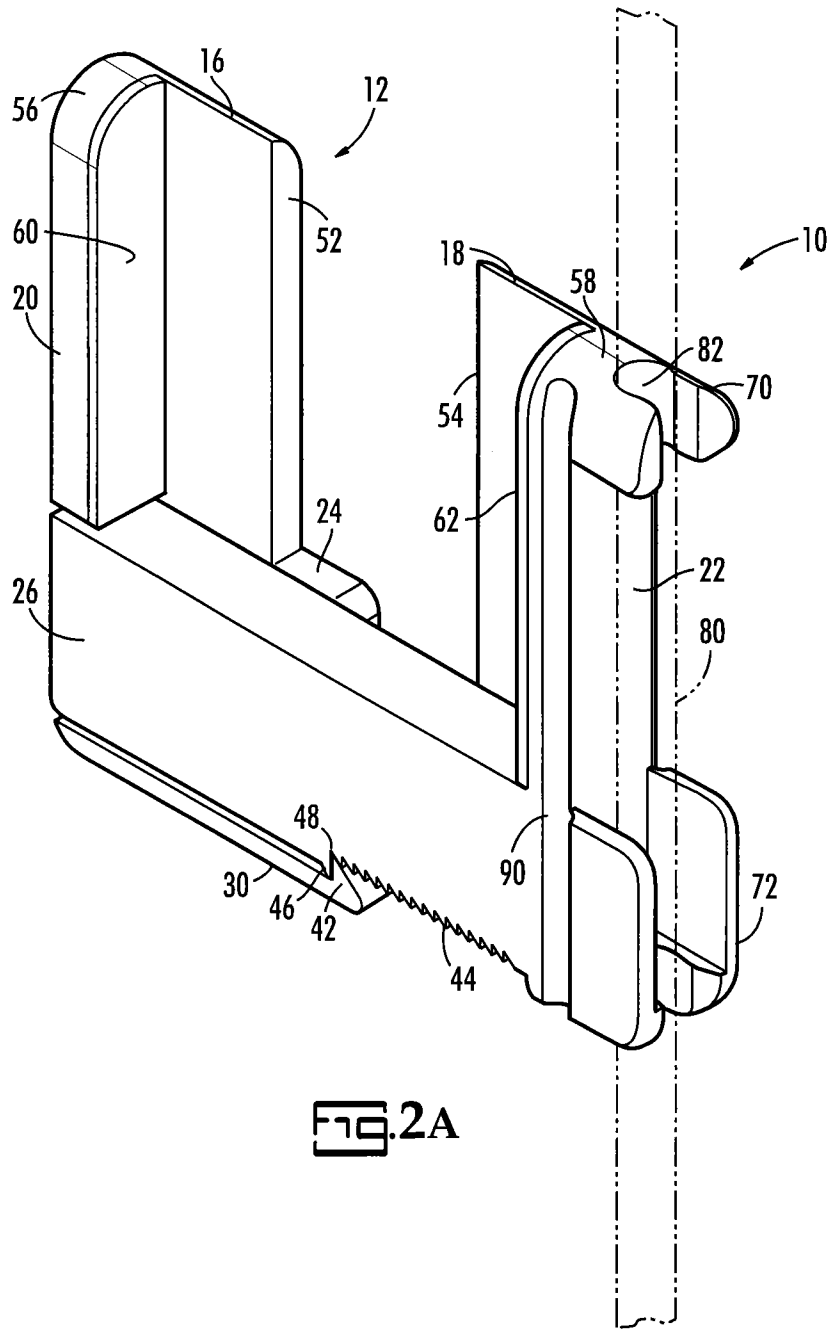
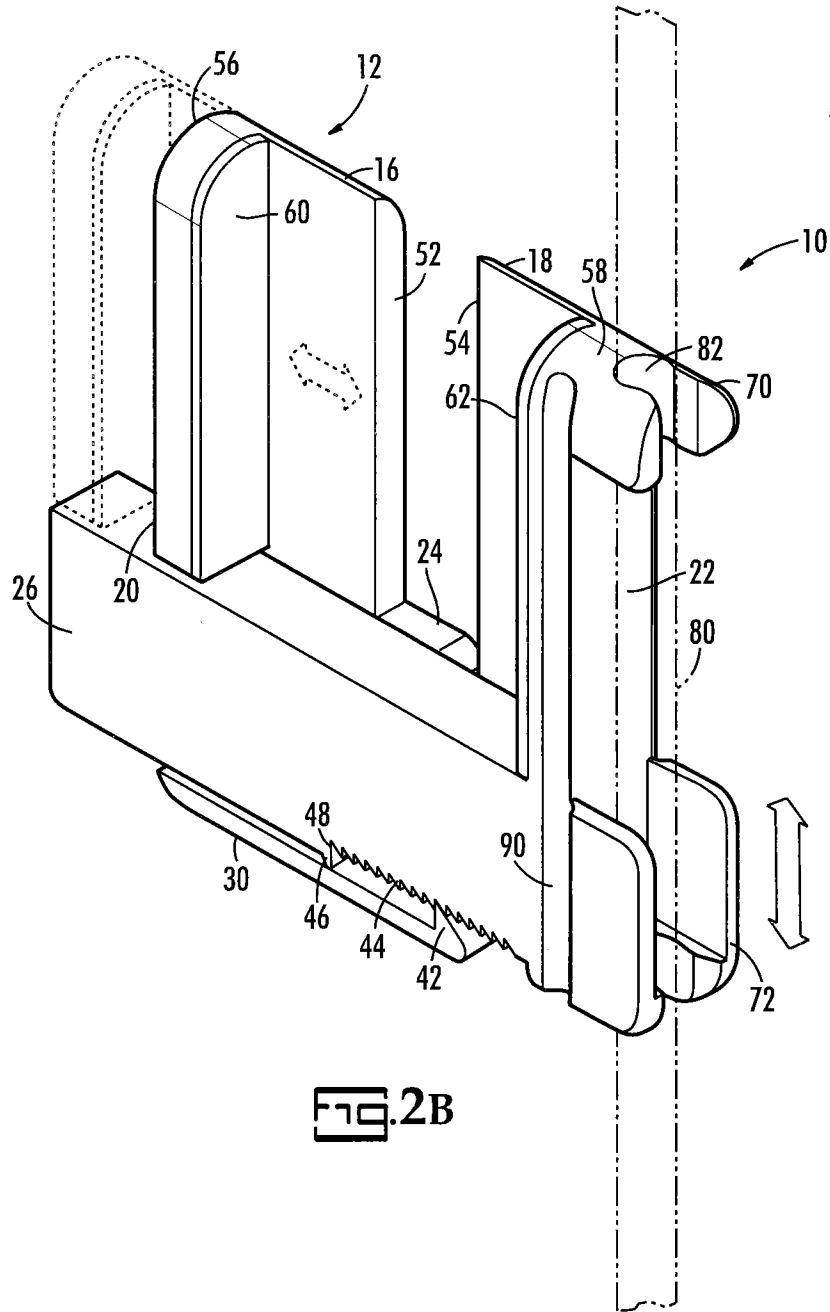
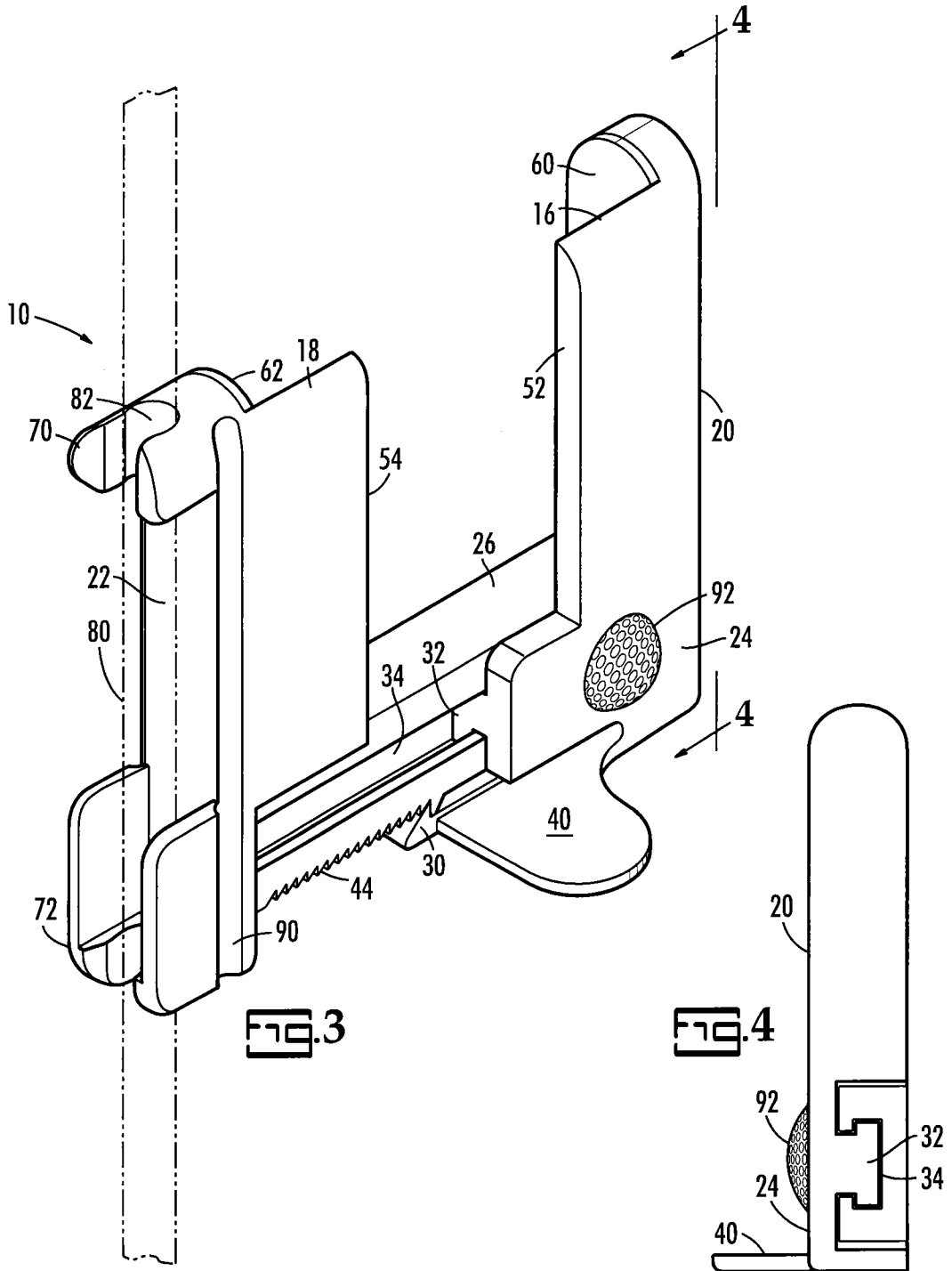

FIG. 2A





A. CLASSIFICATION OF SUBJECT MATTER**G06F 1/16(2006.01)i, H04N 5/225(2006.01)i, H04B 1/38(2006.01)i**

According to International Patent Classification (IPC) or to both national classification and IPC

B. FIELDS SEARCHED

Minimum documentation searched (classification system followed by classification symbols)

G06F 1/16; H04M 1/00; H02J 7/00; G03B 17/00; H04N 5/225; H04B 1/38

Documentation searched other than minimum documentation to the extent that such documents are included in the fields searched

Korean utility models and applications for utility models
Japanese utility models and applications for utility models

Electronic data base consulted during the international search (name of data base and, where practicable, search terms used)

eKOMPASS(KIPO internal) & Keywords: mobile, camcorder, holder, support, tooth, groove, adjustable, rod, clip, ground

C. DOCUMENTS CONSIDERED TO BE RELEVANT

Category*	Citation of document, with indication, where appropriate, of the relevant passages	Relevant to claim No.
X	US 2011-0148352 A1 (YUHUA WANG et al.) 23 June 2011 See paragraphs [0003]-[0017], [0054], [0089]-[0093]; claim 1; and figures 1(a)-1(e).	17
Y		1-6, 14-16
A		7-13, 18-20
Y	US 2011-0091195 A1 (JEFFREY M. GOLDBERG et al.) 21 April 2011 See paragraphs [0001], [0033]-[0043], [0048]-[0051]; and figure 4.	1-6, 14-16
A	US 2008-0234013 A1 (HENRYK BURY) 25 September 2008 See paragraphs [0003], [0010], [0032]-[0033], [0037]-[0038], [0040].	1-20
A	US 2008-0107413 A1 (DARRIN MOORE et al.) 08 May 2008 See paragraphs [0002]-[0004], [0024]-[0029], [0036], [0042].	1-20
A	US 2008-0226284 A1 (ROMAN COPPOLA) 18 September 2008 See paragraphs [0004]-[0008], [0012], [0032]-[0038], [0047].	1-20

 Further documents are listed in the continuation of Box C. See patent family annex.

* Special categories of cited documents:

"A" document defining the general state of the art which is not considered to be of particular relevance

"E" earlier application or patent but published on or after the international filing date

"L" document which may throw doubts on priority claim(s) or which is cited to establish the publication date of citation or other special reason (as specified)

"O" document referring to an oral disclosure, use, exhibition or other means

"P" document published prior to the international filing date but later than the priority date claimed

"T" later document published after the international filing date or priority date and not in conflict with the application but cited to understand the principle or theory underlying the invention

"X" document of particular relevance; the claimed invention cannot be considered novel or cannot be considered to involve an inventive step when the document is taken alone

"Y" document of particular relevance; the claimed invention cannot be considered to involve an inventive step when the document is combined with one or more other such documents, such combination being obvious to a person skilled in the art

"&" document member of the same patent family

Date of the actual completion of the international search

26 June 2013 (26.06.2013)

Date of mailing of the international search report

27 June 2013 (27.06.2013)

Name and mailing address of the ISA/KR



Korean Intellectual Property Office
189 Cheongsa-ro, Seo-gu, Daejeon Metropolitan City,
302-701, Republic of Korea

Facsimile No. 82-42-472-7140

Authorized officer

KIM, Byoung Sung

Telephone No. 82-42-481-8403



INTERNATIONAL SEARCH REPORT

Information on patent family members

International application No.

PCT/US2013/029577

Patent document cited in search report	Publication date	Patent family member(s)	Publication date
US 2011-0148352 A1	23.06.2011	CN 201252539 Y WO 2010-028541 A1	03.06.2009 18.03.2010
US 2011-0091195 A1	21.04.2011	US 8348527 B2	08.01.2013
US 2008-0234013 A1	25.09.2008	AT 452506 T DE 602007003804 D1 EP 1973313 A1 EP 1973313 B1 US 7920905 B2	15.01.2010 28.01.2010 24.09.2008 16.12.2009 05.04.2011
US 2008-0107413 A1	08.05.2008	US 2008-0107412 A1	08.05.2008
US 2008-0226284 A1	18.09.2008	US 2006-0233544 A1 US 2010-0098405 A1 US 7628552 B2 US 8021059 B2	19.10.2006 22.04.2010 08.12.2009 20.09.2011