



US 20180310682A1

(19) **United States**

(12) **Patent Application Publication**
LAW et al.

(10) **Pub. No.: US 2018/0310682 A1**

(43) **Pub. Date: Nov. 1, 2018**

(54) **SUITCASES**

Publication Classification

(71) Applicant: **MAGMATIC LIMITED**, Bristol (GB)

(51) **Int. Cl.**
A45C 13/02 (2006.01)
A45C 5/03 (2006.01)
A45C 5/14 (2006.01)
A45C 7/00 (2006.01)

(72) Inventors: **Robert LAW**, BRISTOL (GB); **Joe ALLUM**, BRISTOL (GB)

(52) **U.S. Cl.**
CPC *A45C 13/02* (2013.01); *A45C 5/03* (2013.01); *A45C 2013/267* (2013.01); *A45C 7/0045* (2013.01); *A45C 5/14* (2013.01)

(73) Assignee: **MAGMATIC LIMITED**, Bristol (GB)

(21) Appl. No.: **15/772,330**

(22) PCT Filed: **Oct. 19, 2016**

(57) **ABSTRACT**

(86) PCT No.: **PCT/GB2016/053256**

§ 371 (c)(1),

(2) Date: **Apr. 30, 2018**

A suitcase is described which has a novel construction that allows for a light, yet spacious piece of luggage that is sufficiently strong to act as an occasional seat. In one aspect, a removable storage box is provided in an upper portion of the suitcase, and in another aspect two pairs of wheels are provided in a lower portion of the suitcase. An example of the suitcase combines the storage box with the wheels arrangement.

(30) **Foreign Application Priority Data**

Oct. 30, 2015 (GB) 1519193.5

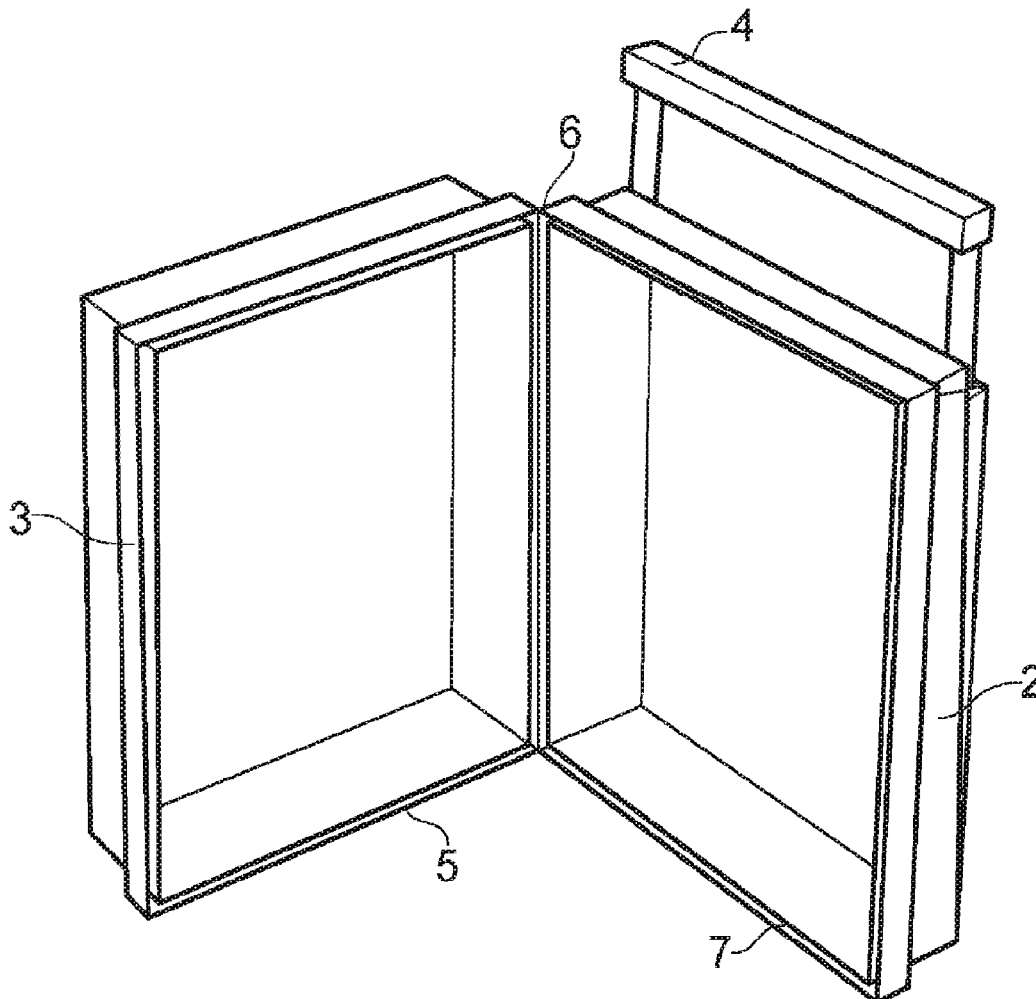

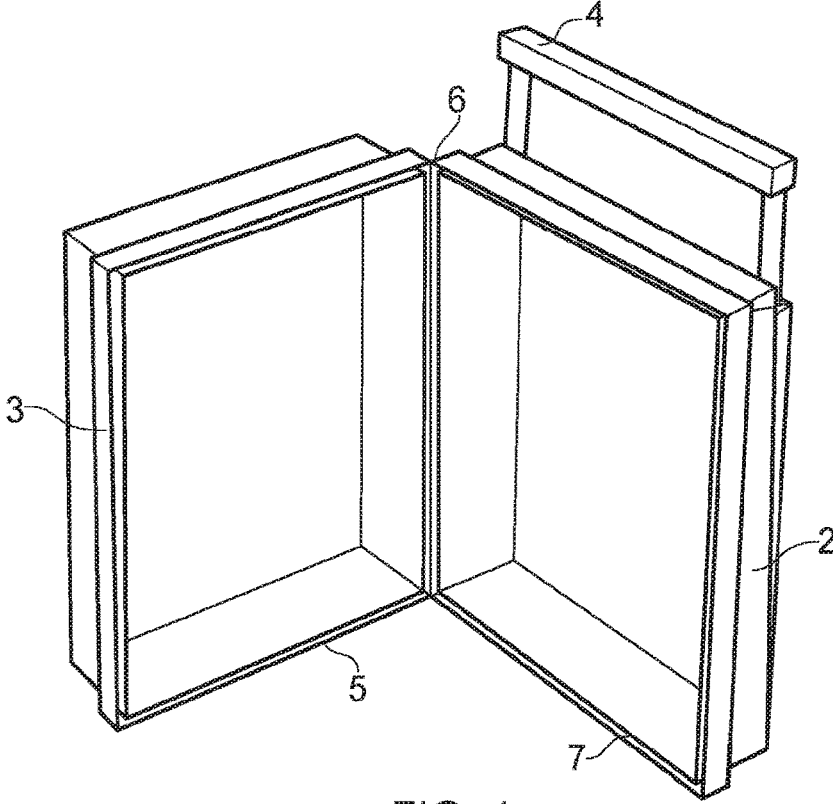

FIG. 1

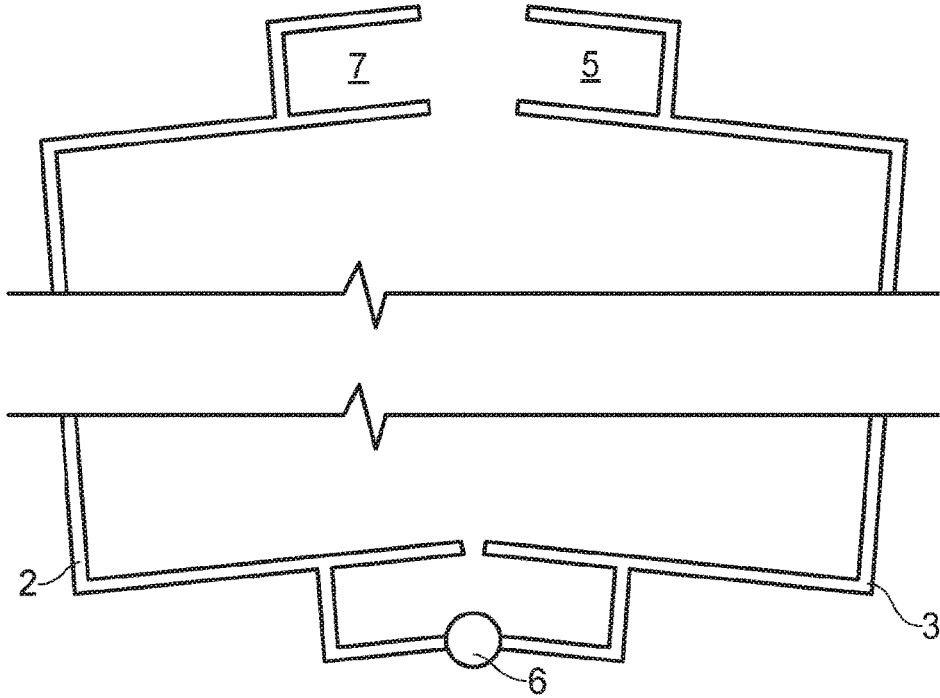

FIG. 2

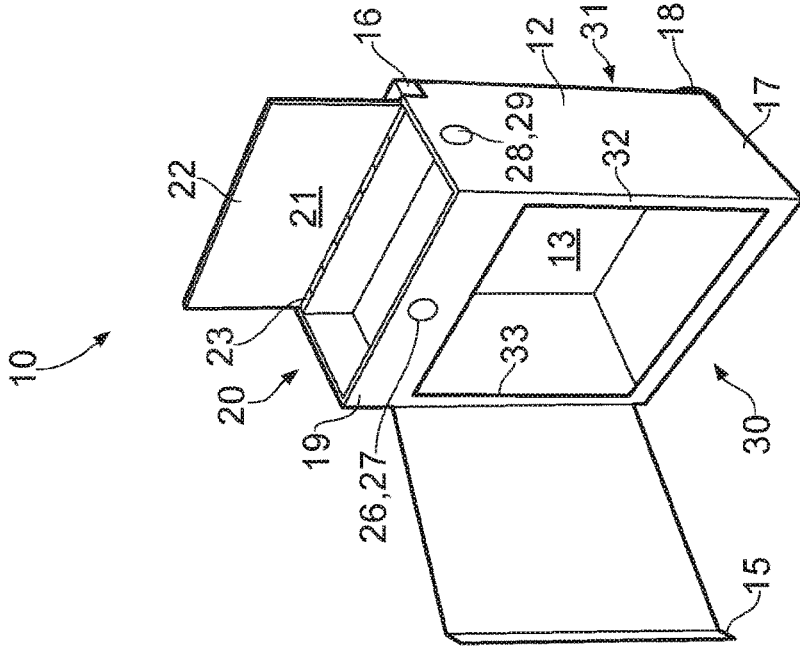

FIG. 3

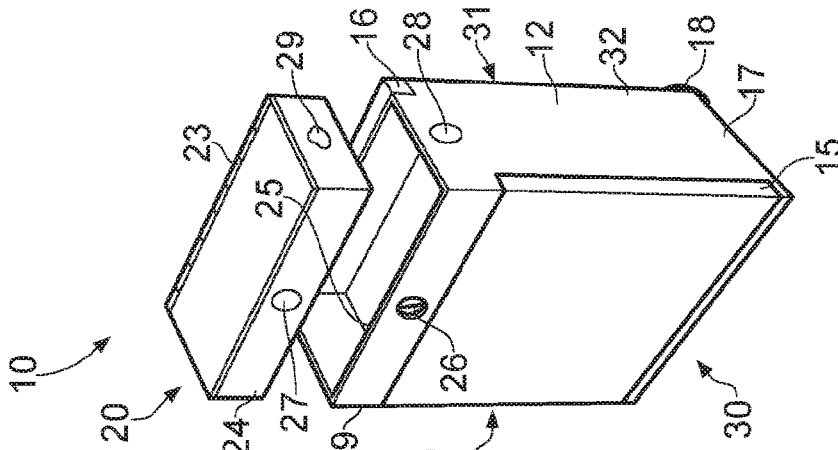

FIG. 4

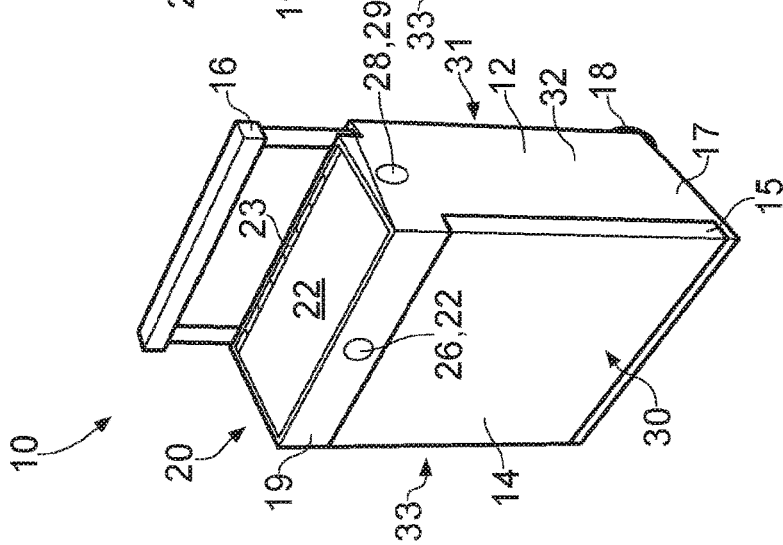

FIG. 5

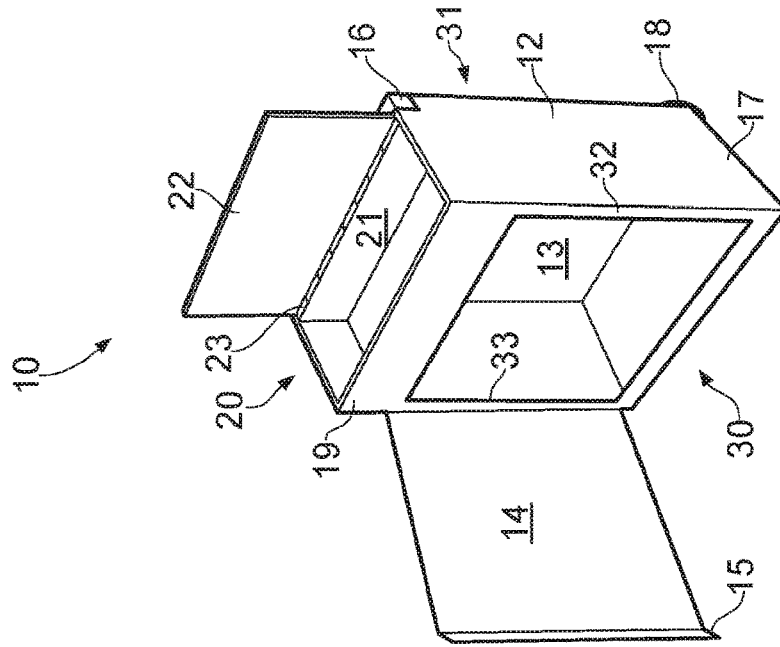

FIG. 6

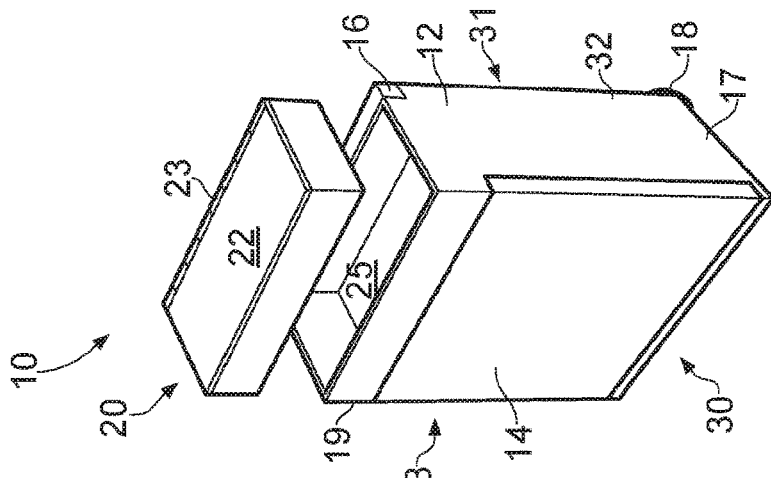

FIG. 7

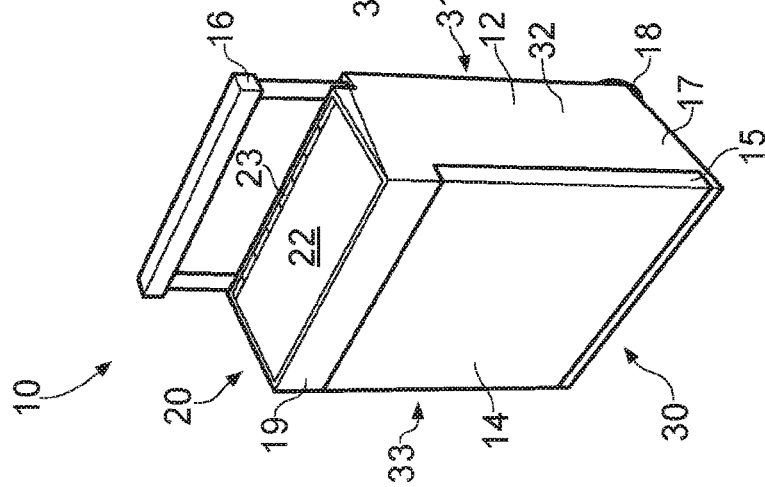

FIG. 8

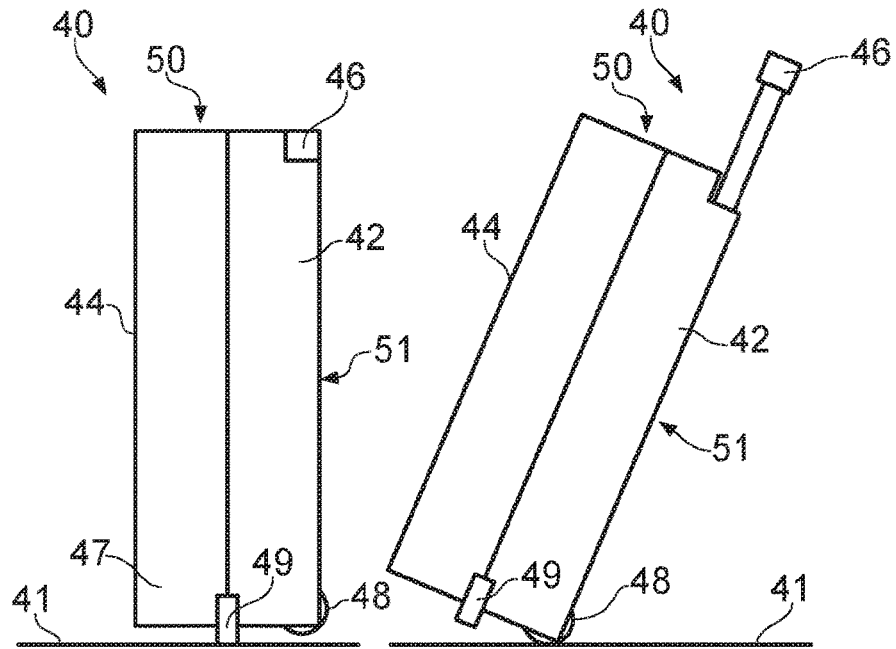

FIG. 9

FIG. 10

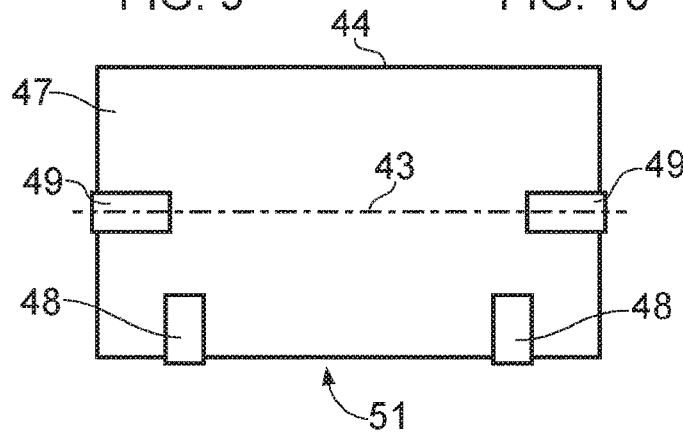

FIG. 11

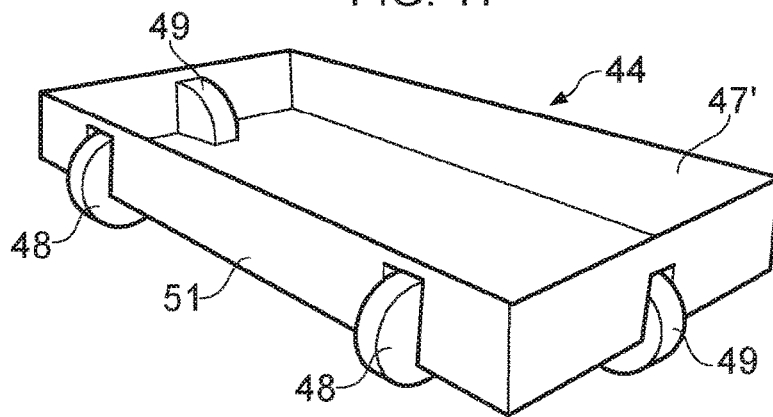

FIG. 12

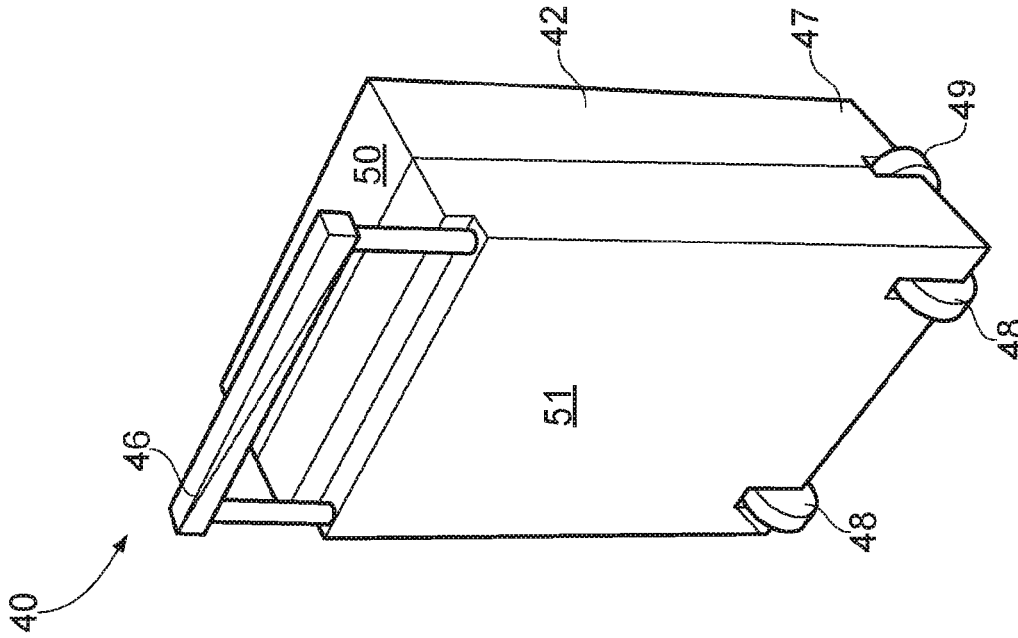

FIG. 14

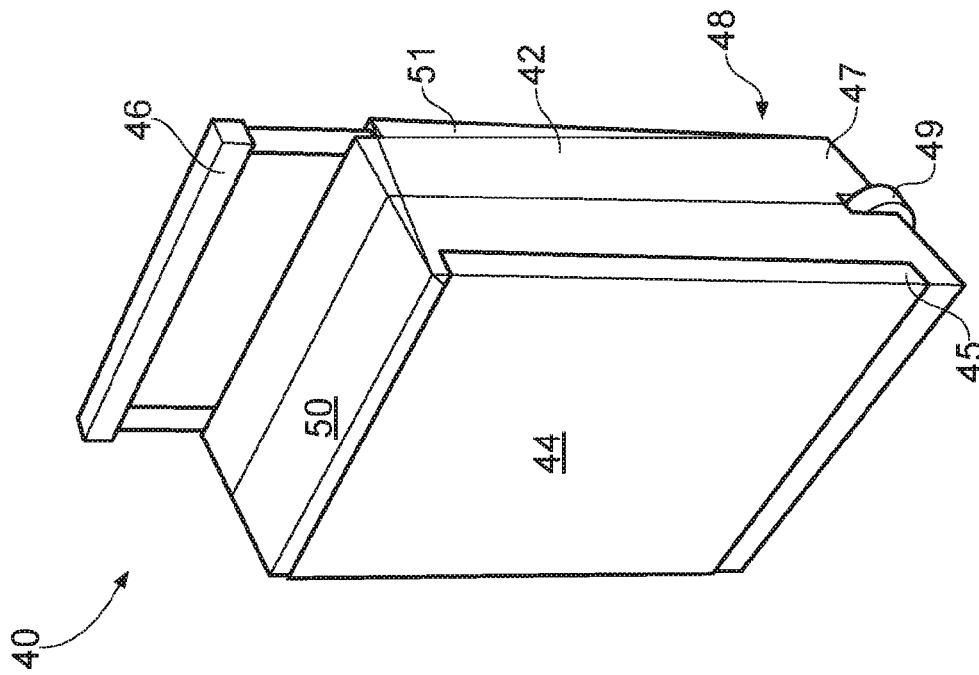

FIG. 13

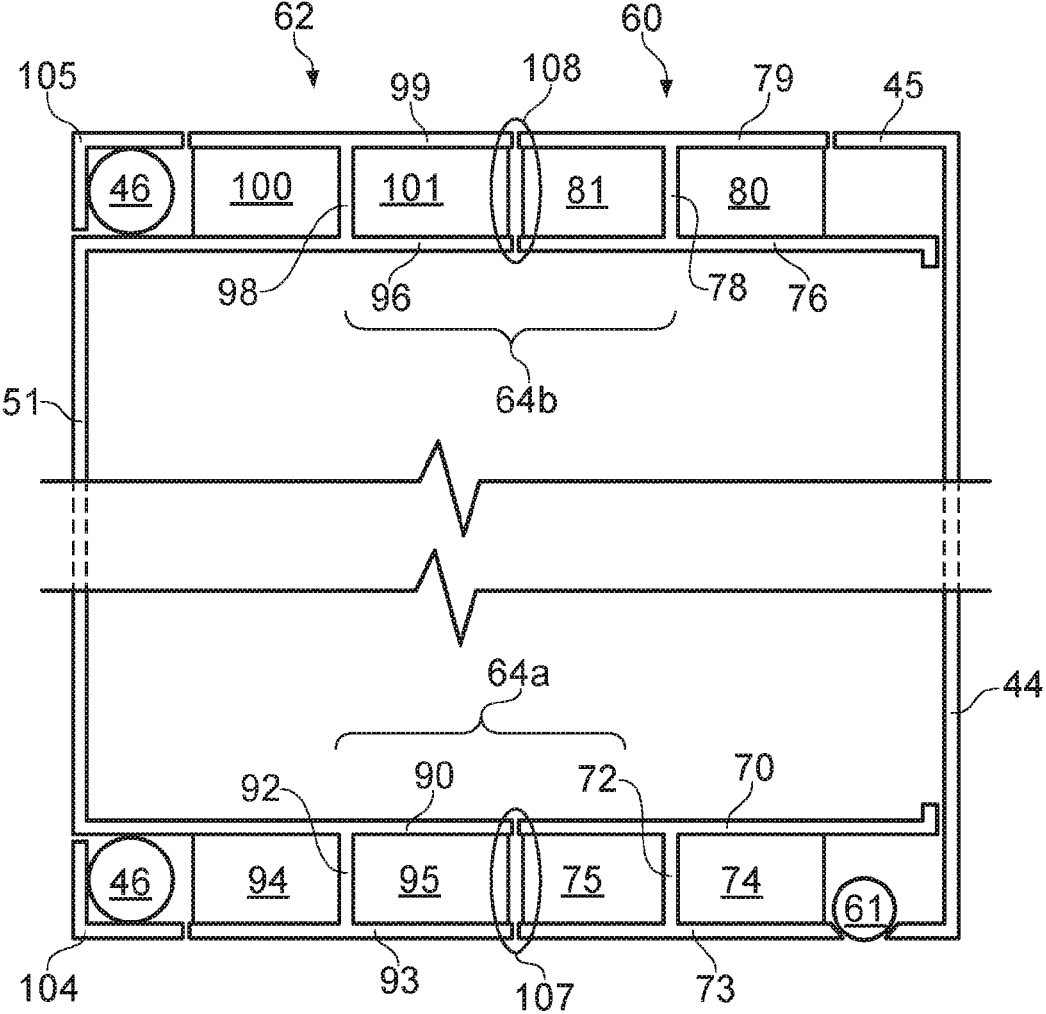

FIG. 17

SUITCASES

[0001] The present invention relates to suitcases.

BACKGROUND OF THE INVENTION

[0002] Suitcases are well known and well used. Existing suitcases, such as that shown in FIGS. 1 and 2 of the accompanying drawings, typically comprise two thin shell body portions 2, 3 that are held together by a releasable closure device, such as a zip, located along respective edge regions 5, 7 of the body portions 2, 3. The two shell body portions 2, 3 are also attached to one another by a hinge 6, which allows the portions to be opened. The body portions 2, 3 each define a hollow volume, which forms part of the inner volume of the suitcase 1. Such suitcases may include additional inner components that divide up the inner volume. In order to access the inner volume of the suitcase 1, the closure device is opened, and the body portions 2, 3 moved apart from one another by rotation about the hinge 6. When the suitcase 1 is in the open position, the thin shell nature of the body portions 2 and 3 means that the structural integrity of the suitcase is lost.

[0003] Other existing designs of suitcase have a single body portion that defines a hollow inner volume. A planar door portion is then provided to allow access to the inner volume of the suitcase. However, such designs have similar drawback to the ones mentioned above.

[0004] Many suitcases are provided with a pair of wheels that extends from a lower edge region of the body of the suitcase, in order to allow a user to cant over the suitcase and pull the suitcase along a ground surface on the wheels. Some suitcases are provided with four wheels which project from a lower surface of the suitcase, and which allow the suitcase to be moved around in an upright position. These wheels are mounted in units for rotation about the lower surface, such that the wheels themselves are able to roll in any direction for the assistance of the user.

[0005] As discussed, such existing suitcases do have drawbacks. For example, the thin shell construction renders the suitcase lacking in structural integrity. In order to overcome this problem, known suitcases make use of thicker and, therefore, heavier material. The wheels mounted on the lower surface of the suitcase are unwieldy, do not integrate well into the suitcase, and contribute to an increased overall size of the suitcase, without increasing the available storage space. Furthermore, existing designs of suitcase do not enable access to the inner volume without the need to open the suitcase fully. Some existing suitcases provide outer pockets, and some provide the ability to attach an additional pouch to the outside of the suitcase. However, such designs are not ideal, since the external pockets are not removable, and an additional storage pouch adds to the outer shape of the suitcase.

[0006] It is, therefore, desirable to provide a suitcase that improves on the existing designs and constructions.

SUMMARY OF THE INVENTION

[0007] According to one aspect of the present invention there is provided a suitcase comprising a case body having a lower portion defining a lower face of the suitcase; an upper portion spaced apart from the lower portion and defining an upper face of the suitcase; first and second side portions which extend from respective ends of the lower portion to respective ends of the upper portion; a rear portion

which extends from a rear edge of the lower portion to a rear edge of the upper portion, and from a rear edge of the first side to a rear edge of the second side, and which provides a rear face of the suitcase; front portion which extends from a front edge of the lower portion to a front edge of the upper portion, and from a front edge of the first side to a front edge of the second side, such that the lower and upper portions, the first and second sides, and the front and rear portions define an inner volume therein, the front portion defining an access aperture therethrough, thereby providing access to the inner volume; and a closure member mounted on the case body and having a first position in which the closure member closes the access aperture, and a second position in which the access aperture is open; and a storage box that defines a storage volume therein, the storage box being releasably located in the upper portion of the suitcase, and being removable from the upper portion of the suitcase when the closure member is in the first position.

[0008] In one example, the storage box includes a storage box body defining the storage volume, and a lid portion having a closed configuration in which the storage volume is closed, and an open configuration in which the storage volume is open. The lid may be rotatably attached to the storage box body.

[0009] The lid may be adapted to seal against the storage box body in the closed configuration, thereby substantially to prevent ingress of water into the storage volume of the storage box. In one example, the lid and storage box body provide releasable engagement means operable to retain the lid in the closed configuration. The engagement means are preferably provided on an outer surface of the storage box body and on the lid.

[0010] The lid of the storage box may be adapted to provide a seat surface for a user. In one example, the lid includes strengthening features, which may be provided by a plurality of spaced apart rib features that extend from an underside surface of the lid into the storage volume when the lid is in the closed configuration.

[0011] Retaining means for retaining the storage box in the upper portion of the case body may be provided. Such retaining means may include a resiliently biased member.

[0012] Locking means for locking the storage box in the upper portion of the case body may be provided. Such locking means may include a resiliently biased member.

[0013] According to another aspect of the present invention, there is provided a suitcase comprising a case body having a lower portion defining a lower face of the suitcase; an upper portion spaced apart from the lower portion and defining an upper face of the suitcase; first and second side portions which extend from respective ends of the lower portion to respective ends of the upper portion; a rear portion which extends from a rear edge of the lower portion to a rear edge of the upper portion, and from a rear edge of the first side to a rear edge of the second side, and which provides a rear face of the suitcase; front portion which extends from a front edge of the lower portion to a front edge of the upper portion, and from a front edge of the first side to a front edge of the second side, such that the lower and upper portions, the first and second sides, and the front and rear portions define an inner volume therein, the front portion defining an access aperture therethrough, thereby providing access to the inner volume; and a closure member mounted on the case body and having a first position in which the closure member closes the access aperture, and a second position in

which the access aperture is open; and a pair of trolley wheels attached to the lower portion of the case body for rotation about a first axis which extends substantially parallel to the rear face of the suitcase; and a pair of inline wheels attached to the lower portion of the case body for rotation about respective second and third axes each of which extends substantially perpendicular to the first axis, wherein the trolley wheels extend outwardly from the rear face of the suitcase, and the inline wheels extend outwardly from the lower face of the suitcase.

[0014] In one example, the inline wheels are located substantially centrally on the lower portion.

[0015] Such a suitcase preferably has a first position in which the trolley wheels engage a surface, and in which the inline wheels are spaced from that surface, and a second position in which the inline wheels engage a surface, and in which the trolley wheels are spaced apart from that surface. Such a suitcase may have an intermediate position in which neither the trolley wheels nor the inline wheels engage a surface, or may have an intermediate position in which the trolley wheels and the inline wheels engage a surface.

[0016] The lower portion may be integrated with the side portions and/or front and/or rear portions. Alternatively, the lower portion may be removable from the side portions, and/or front and/or rear portions.

[0017] According to another aspect of the present invention, there is provided a suitcase that includes the storage box of the first aspect, and the wheel arrangement of the second aspect.

[0018] A suitcase according to any of the above aspects of the present invention may include first and second side portions that include a side portion component comprising an elongate planar side member which extends from the lower portion to the upper portion and from the rear portion to the front portion; an elongate planar surface member which extends substantially parallel to the side member from the lower portion to the upper portion, and at least partially between the rear and front portions; an elongate web which extends between the side member and the surface member, at least partially between the lower and upper portions.

BRIEF DESCRIPTION OF THE DRAWINGS

[0019] FIG. 1 is a schematic perspective view of a previously considered suitcase;

[0020] FIG. 2 is a schematic cross-sectional view of the suitcase of FIG. 1;

[0021] FIG. 3 is a schematic perspective view of a first version of an embodiment of a first aspect of the present invention in a first configuration;

[0022] FIG. 4 is a schematic perspective view of the embodiment of FIG. 3 in a second configuration;

[0023] FIG. 5 is a schematic perspective view of the embodiment of FIG. 3 in a third configuration;

[0024] FIG. 6 is a schematic perspective view of second version of the embodiment of FIG. 3 in the first configuration;

[0025] FIG. 7 is a schematic perspective view of the embodiment of FIG. 6 in a second configuration;

[0026] FIG. 8 is a schematic perspective view of the embodiment of FIG. 6 in a third configuration;

[0027] FIG. 9 is a schematic side view of an embodiment of a second aspect of the present invention in a first configuration;

[0028] FIG. 10 is a schematic side view of the embodiment of FIG. 9 in a second configuration;

[0029] FIG. 11 is a schematic underside plan view of the embodiment of FIG. 9;

[0030] FIG. 12 is a schematic rear perspective view of a lower part of the embodiment of FIGS. 9 and 10;

[0031] FIG. 13 is a schematic front perspective view of a first version of the embodiment of FIG. 9;

[0032] FIG. 14 is a schematic rear perspective view of the first version of the embodiment of FIG. 9;

[0033] FIG. 15 is a schematic front perspective view of a second version of the embodiment of FIG. 9;

[0034] FIG. 16 is a schematic rear perspective view of the second version of the embodiment of FIG. 9; and

[0035] FIG. 17 illustrates an example construction of the embodiments of the present invention.

DETAILED DESCRIPTION OF THE PREFERRED EMBODIMENTS

[0036] FIGS. 3, 4 and 5 illustrate a first version of a suitcase 10 embodying a first aspect of the present invention in respective configurations. The suitcase 10 comprises a case body 12 which encloses an inner volume 13. The case body 12 has a lower portion 17, and an upper portion 19 which is spaced apart from the lower portion 17. Substantially planar front, rear and first and second side portions 30, 31, 32 and 33 extend from the lower portion 17 to the upper portion 19 and define therein the inner volume 13 of the suitcase 10. The front portion 30 defines an access aperture, through which access to the inner volume 13 is possible.

[0037] The case body 12 is provided with a closure member 14 to a front side of the case body. The closure member is rotatably attached to one of the first and second side portions 32 and 33 and is releasably engageable, via an engagement portion 15, with the other of the side portions 33 and 32. The closure member 14 is shown in a closed configuration in FIGS. 3 and 4, and in an open configuration in FIG. 5. The arrangement of the closure member 14 allows the suitcase 10 to be opened whilst in an upright position.

[0038] An extendable handle 16 is provided, and is extendable from the rear portion 31 of the case body 12. In FIG. 3, the extendable handle 16 is shown in a partially extended, deployed configuration. In FIGS. 4 and 5, the handle 16 is shown in a stowed position.

[0039] A pair of trolley wheels 18 are mounted on the lower portion 17. The trolley wheels 18 are arranged for rotation about an axis substantially parallel to the plane of the rear portion 31. The wheels 18 enable the suitcase to be pulled along the ground by the user, preferably using the handle 16.

[0040] A removable storage box 20 is provided in the upper portion 19 of the case body 12. The upper storage box 20 has a storage box body 24 which defines a storage volume 21. The storage volume 21 is closed by a lid 22, which is hinged to the storage box 20 using a hinge member 23. The lid 22 is shown in a closed configuration in FIGS. 3 and 4, and in an open configuration in FIG. 5.

[0041] Preferably, the lid 22 forms a substantially watertight seal with the storage box body 24, so as to resist water ingress into the storage volume 21 of the storage box body 24. In a preferred example, the lid 22 and storage box body 24 are provided with releasable engagement means for holding the lid in the closed configuration. Preferably, the engagement means are provided on an outer surface of the

storage box body and a corresponding surface of the lid 22, so that the substantially watertight seal is not compromised by the engagement means.

[0042] In one example, the lid includes strengthening features, which may be provided by a plurality of spaced apart rib features that extend from an underside surface of the lid into the storage volume when the lid is in the closed configuration.

[0043] As illustrated in FIG. 4, the storage box 20 is removable from the upper portion 19 of the case body 12. The storage box body 24 is locatable in a corresponding receiving zone 25 define in the upper portion 19 of the case body 12. FIG. 3 shows the storage box in place in the receiving zone 25, in a closed configuration with the lid 22 closed. FIG. 4 shows the storage box 20 removed from the receiving zone 25, also in a closed configuration with the lid 22 closed. FIG. 5 shows the storage box 20 in place in the receiving zone 25 in an open configuration with the lid 22 open. It will be appreciated that the lid 22 may be opened when the storage box is located in the receiving zone 25, or when removed from the receiving zone 25.

[0044] The storage box 20 and upper portion 19 include a lock mechanism 26, 27 and a retaining means 28, 29 which serve to lock and retain the storage box 20 in the upper portion 19 of the case body 12. The lock mechanism comprises a locking protrusion 27, and a locking aperture 26 in the upper portion 19, through which the locking protrusion extends when the storage box is in place in the receiving zone 25. The locking protrusion 27 has a locked position in which the protrusion extends out of the storage box body 24, such that it is able to engage with a side of the locking aperture 26 to prevent the removal of the storage box 20 from the receiving zone 25. The locking protrusion can be locked in the locked position, and can be unlocked to allow the protrusion 27 to be moved to a second position in which the protrusion does not engage with the side of the locking aperture 26. The locking protrusion 27 is preferably resiliently biased with respect to the storage box body 24, such that the locking protrusion 27 returns to the locking position when released by the user.

[0045] The retaining means comprises a retaining protrusion 29 located on the storage box body 24, and a retaining aperture 28 in the upper portion 19, through which the retaining protrusion 29 extends when the storage box is in place in the receiving zone 25. The retaining protrusion 27 has a retaining position in which the protrusion extends out of the storage box body 24, such that it is able to engage with a side of the retaining aperture 28 to prevent the removal of the storage box 20 from the receiving zone 25. The retaining protrusion is movable by the user into the storage box body 24 to a position in which the retaining protrusion 29 does not engage with the side of the retaining aperture 28. The retaining protrusion is preferably resiliently biased with respect to the storage box body 24, such that the retaining protrusion 29 returns to the retaining position when released by the user.

[0046] In order to remove the storage box 20 from the upper portion 19 of the case body 12, the user unlocks the locking protrusion 27, and depresses the protrusion 27 into the storage box body 24. The retaining protrusion 29 is also disengaged from the upper portion 19 of the case body. The storage box can then be removed from the upper portion of the case body 12, as shown in FIG. 4.

[0047] The storage box 20 is integrated within the overall outline of the suitcase 10. The storage box 20 is removable from the suitcase 10 without the need to open the suitcase 10, thereby providing the user with increased utility. In addition, the upper surface of the storage box 20 can provide a seating surface for the user.

[0048] FIGS. 6 to 8 illustrate a second version of a suitcase 10 embodying a first aspect of the present invention in respective configurations. As in FIGS. 3 to 5, the suitcase 10 comprises a case body 12 which encloses an inner volume 13. The case body 12 has a lower portion 17, and an upper portion 19 which is spaced apart from the lower portion 17. Substantially planar front, rear and first and second side portions 30, 31, 32 and 33 extend from the lower portion 17 to the upper portion 19 and define therein the inner volume 13 of the suitcase 10. The front portion 30 defines an access aperture, through which access to the inner volume 13 is possible.

[0049] The case body 12 is provided with a closure member 14 to a front side of the case body. The closure member is rotatably attached to one of the first and second side portions 32 and 33 and is releasably engageable, via an engagement portion 15, with the other of the side portions 33 and 32. The closure member 14 is shown in a closed configuration in FIGS. 3 and 4, and in an open configuration in FIG. 5. The arrangement of the closure member 14 allows the suitcase 10 to be opened whilst in an upright position.

[0050] An extendable handle 16 is provided, and is extendable from the rear portion 31 of the case body 12. In FIG. 3, the extendable handle 6 is shown in a partially extended, deployed configuration. In FIGS. 4 and 5, the handle 16 is shown in a stowed position.

[0051] A pair of trolley wheels 18 are mounted on the lower portion 17. The trolley wheels 18 are arranged for rotation about an axis substantially parallel to the plane of the rear portion 31. The wheels 18 enable the suitcase to be pulled along the ground by the user, preferably using the handle 16.

[0052] A removable storage box 20 is provided in the upper portion 19 of the case body 12. The upper storage box 20 has a storage box body 24 which defines a storage volume 21. The storage volume 21 is closed by a lid 22, which is hinged to the storage box 20 using a hinge member 23. The lid 22 is shown in a closed configuration in FIGS. 3 and 4, and in an open configuration in FIG. 5.

[0053] Preferably, the lid 22 forms a substantially watertight seal with the storage box body 24, so as to resist water ingress into the storage volume 21 of the storage box body 24.

[0054] As illustrated in FIG. 4, the storage box 20 is removable from the upper portion 19 of the case body 12. The storage box body 24 is locatable in a corresponding receiving zone 25 define in the upper portion 19 of the case body 12. FIG. 3 shows the storage box in place in the receiving zone 25, in a closed configuration with the lid 22 closed. FIG. 4 shows the storage box 20 removed from the receiving zone 25, also in a closed configuration with the lid 22 closed. FIG. 5 shows the storage box 20 in place in the receiving zone 25 in an open configuration with the lid 22 open. It will be appreciated that the lid 22 may be opened when the storage box is located in the receiving zone 25, or when removed from the receiving zone 25.

[0055] In contrast with the first version, the second version of the suitcase embodying the first aspect of the present

invention does not include locking or retaining means. In the second version, the storage box 20 is simply removable from the upper portion 19, and is retained in the upper portion 19 by a friction fit of the storage box body 24 in the upper portion 19 of the case body 12.

[0056] As in the first version, the storage box 20 is integrated within the overall outline of the suitcase. The storage box 20 is removable from the suitcase 10 without the need to open the suitcase 10, thereby providing the user with increased utility. In addition, the upper surface of the storage box 20 can provide a seating surface for the user.

[0057] FIGS. 9 to 16 illustrate schematically a second suitcase 40 embodying another aspect of the present invention. FIG. 9 shows a side view in a first configuration, FIG. 10 shows a side view in a second configuration, and FIG. 11 shows an underside plan view of the third suitcase 40. FIG. 12 shows a perspective view of a lower portion 47 of the second suitcase 40. FIGS. 13 and 14 show front and rear perspective views of a first version of the second suitcase 40 respectively, and FIGS. 15 and 16 show front and rear perspective views of a second version of the second suitcase 40 respectively.

[0058] The second suitcase 40 comprises a case body 42, a closure member 44, and an extendable handle 46. The case body 42 defines an inner volume, accessible by way of an access aperture on a front face of the case body 42. The closure member 44 serves to close the aperture, and can be opened in which the aperture is open to allow access to the inner volume of the suitcase. The extendable handle 46 is located in the case body 42 and is movable between a stowed position (FIG. 9) and a deployed position (FIG. 10).

[0059] The case body 42 has a lower portion 47, and an upper portion 49 which is spaced apart from the lower portion 47. Substantially planar front, rear and first and second side portions extend from the lower portion 47 to the upper portion 49 and define therein the inner volume of the second suitcase 40.

[0060] A pair of trolley wheels 48 is mounted on a rear region of the lower portion 47. The trolley wheels are arranged to rotate about an axis which is substantially parallel to the plane of the rear portion of the case body 42. The axis of rotation of the trolley wheels 48 is substantially parallel to the centre line of the second suitcase 40, the centre line 43 running from one side portion to the other side portion of the case body 42.

[0061] A pair of inline wheels 49 is mounted on the lower portion 47. Each of the inline wheels 49 is mounted for rotation about an axis which is substantially perpendicular to the axis of rotation of the trolley wheels 48. The inline wheels 49 are located substantially centrally on the lower portion 47, substantially along the centre line 43 that extends from the first side portion to the second side portion.

[0062] In a first, upright, position (as shown in FIG. 9), the inline wheels 49 engage the ground 41, and the trolley wheels 48 are clear of the ground 41. In this upright position, the user is able to roll the suitcase 40 along the ground in a direction parallel to the centre line 43 of the suitcase body. The trolley wheels 38 do not interfere with this movement. The user may sit on the upper surface 50 of the suitcase 40, and propel themselves along the ground 41 on the inline wheels 49.

[0063] In a second, inclined, position (as shown in FIG. 10), the trolley wheels 48 engage the ground 41, and the inline wheels 49 are clear of the ground 41. In this position,

the user is able to move the suitcase 40 along the ground 41, preferably using the handle 46, in a conventional trolley manner.

[0064] In one example suitcase, there is an intermediate position in which neither the trolley wheels 48 nor the inline wheels 49 engage the ground 41. In this intermediate position, all or part of a lower rear edge region of the suitcase 40 engages the ground 41.

[0065] In another example suitcase, there is an intermediate position between the first and second positions in which both the trolley wheels 48 and the inline wheels 49 engage the ground. In this intermediate position, the suitcase 40 is prevented from rolling across the ground 41, since the wheels 48 and 49 are arranged to rotate in mutually exclusive substantially perpendicular directions.

[0066] The lower portion 47 may be integral with the case body 42, as shown in the example of FIGS. 9, 10, 13 and 14, or may be a separate removable component 47' as shown in FIG. 12. A second version of the second suitcase 40 using this separate lower portion 47' is shown in FIGS. 15 and 16. The lower portion 47' may be removed to facilitate the removal, repair and/or replacement of the wheels 48 and 49.

[0067] A preferred construction of the first and second suitcase 10 and 40 is illustrated in FIG. 17.

[0068] FIG. 17 illustrates a cross-sectional view of a suitcase, and shows a preferred construction of the suitcase. The suitcase comprises first and second body portions 60 and 62 that provide the suitcase with the necessary strength and rigidity. As will be described in more detail below, the first and second body portions 60 and 62 provide first and second side portions 64a and 64b each of which has an I-beam construction, having a double wall structure interconnected by one or more strengthening webs and ribs. The first and second body portions 60 and 62 also provide lower and upper portions which extend between respective lower end regions and upper end regions of the first and second side portions 60 and 62. This construction also provides suitable locations for the extendable handle 46 and for a hinge 61 of the closure member 44.

[0069] The first side portion 64a of the first body portion 60 comprises an elongate planar inner member 70. The inner member 70 extends from the upper portion to the lower portion of the first body portion 60. An elongate planar outer member 73 extends substantially parallel to the inner member 70, and is spaced apart from that inner member 70. The outer member 73 extends from the upper portion to the lower portion of the first body portion 60, and forms the outer side surface of the case body 11.

[0070] In order to provide the required strength and rigidity for the suitcase 10, the outer member 73 is attached to the inner member 70 by a substantially planar elongate web 72 that extends substantially perpendicularly to each of the inner member 70 and outer surface member 73.

[0071] In one example, the web 72 extends along the complete length of the side member 70 from the upper portion to the lower portion of the first body portion 60. In other examples, the web 72 extends partially along the inner member 70.

[0072] As shown, in a preferred example, a plurality of ribs 74 and 75 also join the inner member 70 to the outer member 73. Respective pluralities of such ribs 74 and 75 extend to first and second sides of the web 72, substantially perpendicularly to the web 72, and to the inner and outer members 70 and 73. The ribs 74 and 75 are spaced apart

from one another along the length of the web 72. Any appropriate number of ribs can be provided.

[0073] Similarly, to the first side portion 64a, the second side portion 64b comprises an elongate planar inner member 76. The inner member 76 extends from the upper portion to the lower portion of the first body portion 60. An elongate planar outer member 79 extends substantially parallel to the inner member 76, and is spaced apart from that inner member 76. The outer member 79 extends from the upper portion to the lower portion of the first body portion 60, and forms the outer side surface of the case body 11.

[0074] In order to provide the required strength and rigidity for the suitcase 10, the outer member 79 is attached to the inner member 76 by a substantially planar elongate web 78 that extends substantially perpendicularly to each of the inner member 76 and outer surface member 79. In one example, the web 78 extends along the complete length of the side member 76 from the upper portion to the lower portion of the first body portion 60. In other examples, the web 78 extends partially along the inner member 76.

[0075] As shown, in a preferred example, a plurality of ribs 80 and 81 also join the inner member 76 to the outer member 79. Respective pluralities of such ribs 80 and 81 extend to first and second sides of the web 78, substantially perpendicularly to the web 78, and to the inner and outer members 76 and 79. The ribs 80 and 81 are spaced apart from one another along the length of the web 78. Any appropriate number of ribs can be provided.

[0076] The first body portion 60 is preferably moulded as a single component using a plastics material and an injection moulding technique. The construction of the first body portion 60 is able to provide a strong and rigid component for the suitcase.

[0077] The hinge 61 for the closure member 44 is provided adjacent the inner and outer members 70 and 73 of the first side portion 64a of the first body portion 60. The hinge 61 is an elongate member which extends at least partially along the front edge corner region of the first side member 64a. The hinge 61 thereby serves to close at least partially an open front edge region of the second side portion 64a of the first body portion 60.

[0078] The second side portion 64b of the first body portion 60 provides a location for the engagement portion 45 of the closure member 44 to engage when the closure member 19a is in the closed configuration. An appropriate catch or receiving/engagement means may be provided to hold the engagement portion 45 in place, and hence hold the closure member 19a in the closed configuration. The engagement portion 45 of the closure member 44 also serves to close at least partially an open front edge region of the second side portion 64b of the first body portion 61.

[0079] The second body portion 62 is constructed in a similar manner to the first body portion 60. The first side portion 64a of the second body portion 62 comprises an elongate planar inner member 90. The inner member 90 extends from the upper portion to the lower portion of the first body portion 62. An elongate planar outer member 97 extends substantially parallel to the inner member 90, and is spaced apart from that inner member 90. The outer member 97 extends from the upper portion to the lower portion of the second body portion 62, and forms part of the outer side surface of the case body 11.

[0080] In order to provide the required strength and rigidity for the suitcase 10, the outer member 97 is attached to the

inner member 90 by a substantially planar elongate web 92 that extends substantially perpendicularly to each of the inner member 90 and outer member 93. In one example, the web 92 extends along the complete length of the side member 90 from the upper portion to the lower portion of the second body portion 62. In other examples, the web 92 extends partially along the inner member 90.

[0081] As shown, in a preferred example, a plurality of ribs 94 and 95 also join the inner member 90 to the outer member 93. Respective pluralities of such ribs 94 and 95 extend to first and second sides of the web 92, substantially perpendicularly to the web 92, and to the inner and outer members 90 and 93. The ribs 94 and 95 are spaced apart from one another along the length of the web 92. Any appropriate number of ribs can be provided.

[0082] Similarly, to the first side portion 64a, the second side portion 64b comprises an elongate planar inner member 96. The inner member 96 extends from the upper portion to the lower portion of the second body portion 62. An elongate planar outer member 99 extends substantially parallel to the inner member 96, and is spaced apart from that inner member 96. The outer member 99 extends from the upper portion to the lower portion of the second body portion 62, and forms part of the outer side surface of the case body 11.

[0083] In order to provide the required strength and rigidity for the suitcase 10, the outer member 99 is attached to the inner member 96 by a substantially planar elongate web 98 that extends substantially perpendicularly to each of the inner member 96 and outer surface member 99. In one example, the web 98 extends along the complete length of the side member 96 from the upper portion to the lower portion of the second body portion 62. In other examples, the web 98 extends partially along the inner member 96.

[0084] As shown, in a preferred example, a plurality of ribs 100 and 101 also join the inner member 96 to the outer member 99. Respective pluralities of such ribs 100 and 101 extend to first and second sides of the web 98, substantially perpendicularly to the web 98, and to the inner and outer members 96 and 99. The ribs 100 and 101 are spaced apart from one another along the length of the web 98. Any appropriate number of ribs can be provided.

[0085] The second body portion 62 is preferably moulded as a single component using a plastics material and an injection moulding technique. The construction of the second body portion 62 is able to provide a strong and rigid component for the suitcase 10. The second body portion 62 also includes the rear closure face 91.

[0086] The first and second side portions 64a and 64b of the second body portion provide a fitting location for the extendable handle 46. A pair of cover portions 104 and 105 may be provided in order to enclose the shafts of the extendable handle. Each cover portion may be welded or bonded to the inner member and to the outer member, so as to completely enclose an associated shaft of the extendable handle 46. The shafts of the extendable handle 46 also serve to cover open end regions of the first and second side portions 64a and 64b to the rear of the suitcase.

[0087] In order to complete suitcase 10, the first and second body portions 60 and 62 are bonded together, such that respective edges of the inner members 70 and 76, outer members 73 and 79, and ribs 75 and 81 of the first body portion 60 are connected to corresponding respective edges of the inner members 90 and 96, outer members 93 and 99 and ribs 95 and 101 of the second body portion 62 in

bonding regions **107** and **108**. The components may be bonded using adhesive, an ultrasonic bonding method, or any other suitable technique. The bonding regions **107** and **108** preferably extend along the complete length of the first and second side portions **64a** and **64b**, and along the length of the upper and lower portions **18c** and **18d**.

[0088] In an alternative embodiment, the first body portion **60** provides the complete side portions **64a** and **64b**, and upper and lower portions, with the second body portion providing only the rear closure face **51**. In another alternative embodiment, the first body portion **60** provides the complete side portions **64a** and **64b**, and upper and lower portions, and includes the rear closure face **19b**. In another alternative embodiment, the second body portion provides the complete side portions **64a** and **64b**, and upper and lower portions.

1. A suitcase comprising:
 - a case body having:
 - a lower portion defining a lower face of the suitcase;
 - an upper portion spaced apart from the lower portion and defining an upper face of the suitcase;
 - first and second side portions which extend from respective ends of the lower portion to respective ends of the upper portion;
 - a rear portion which extends from a rear edge of the lower portion to a rear edge of the upper portion, and from a rear edge of the first side to a rear edge of the second side, and which provides a rear face of the suitcase;
 - front portion which extends from a front edge of the lower portion to a front edge of the upper portion, and from a front edge of the first side to a front edge of the second side, such that the lower and upper portions, the first and second sides, and the front and rear portions define an inner volume therein, the front portion defining an access aperture therethrough, thereby providing access to the inner volume; and
 - a closure member mounted on the case body and having a first position in which the closure member closes the access aperture, and a second position in which the access aperture is open; and
 - a storage box that defines a storage volume therein, the storage box being releasably located in the upper portion of the suitcase, and being removable from the upper portion of the suitcase when the closure member is in the first position, and retaining means for retaining the storage box in the upper portion of the case body, the retaining means including a resiliently biased member.
2. A suitcase as claimed in claim 1, wherein the storage box includes a storage box body defining the storage volume, and a lid portion having a closed configuration in which the storage volume is closed, and an open configuration in which the storage volume is open.
3. A suitcase as claimed in claim 1, wherein the storage box includes a storage box body defining the storage volume, and a lid portion having a closed configuration in which the storage volume is closed, and an open configuration in which the storage volume is open, and wherein the lid is rotatably attached to the storage box body.
4. A suitcase as claimed in claim 1, wherein the storage box includes a storage box body defining the storage volume, and a lid portion having a closed configuration in which the storage volume is closed, and an open configuration in which the storage volume is open, and wherein the

lid is adapted to seal against the storage box body in the closed configuration, thereby substantially to prevent ingress of water into the storage volume of the storage box.

5. A suitcase as claimed in claim 1, wherein the storage box includes a storage box body defining the storage volume, and a lid portion having a closed configuration in which the storage volume is closed, and an open configuration in which the storage volume is open, and wherein the lid is adapted to seal against the storage box body in the closed configuration, thereby substantially to prevent ingress of water into the storage volume of the storage box, and wherein the lid and storage box body provide releasable engagement means operable to retain the lid in the closed configuration.

6. A suitcase as claimed in claim 1, wherein the storage box includes a storage box body defining the storage volume, and a lid portion having a closed configuration in which the storage volume is closed, and an open configuration in which the storage volume is open, and wherein the lid is adapted to seal against the storage box body in the closed configuration, thereby substantially to prevent ingress of water into the storage volume of the storage box, and wherein the lid and storage box body provide releasable engagement means operable to retain the lid in the closed configuration, and wherein the engagement means are provided on an outer surface of the storage box body and on the lid.

7. A suitcase as claimed in claim 1, wherein the lid of the storage box is adapted to provide a seat surface for a user.

8. A suitcase as claimed in claim 7, wherein the lid of the storage box is adapted to provide a seat surface for a user, and wherein the lid includes strengthening features.

9. A suitcase as claimed in claim 8, wherein the lid of the storage box is adapted to provide a seat surface for a user, and wherein the lid includes strengthening features provided by a plurality of spaced apart rib features that extend from an underside surface of the lid into the storage volume when the lid is in the closed configuration.

10. A suitcase as claimed in claim 1, further comprising locking means for locking the storage box in the upper portion of the case body.

11. A suitcase as claimed in claim 1, further comprising locking means for locking the storage box in the upper portion of the case body, wherein locking means includes a resiliently biased member.

12. A suitcase comprising:

- a case body having:
 - a lower portion defining a lower face of the suitcase;
 - an upper portion spaced apart from the lower portion and defining an upper face of the suitcase;
- first and second side portions which extend from respective ends of the lower portion to respective ends of the upper portion;
- a rear portion which extends from a rear edge of the lower portion to a rear edge of the upper portion, and from a rear edge of the first side to a rear edge of the second side, and which provides a rear face of the suitcase;
- front portion which extends from a front edge of the lower portion to a front edge of the upper portion, and from a front edge of the first side to a front edge of the second side, such that the lower and upper portions, the first and second sides, and the front and rear portions define

an inner volume therein, the front portion defining an access aperture therethrough, thereby providing access to the inner volume; and

a closure member mounted on the case body and having a first position in which the closure member closes the access aperture, and a second position in which the access aperture is open; and

a pair of trolley wheels attached to the lower portion of the case body for rotation about a first axis which extends substantially parallel to the rear face of the suitcase; and

a pair of inline wheels attached to the lower portion of the case body for rotation about respective second and third axes which are substantially parallel to one another, and each of which extends substantially perpendicular to the first axis,

wherein the trolley wheels extend outwardly from the rear face of the suitcase, and the in line wheels extends outwardly from the lower face of the suitcase, wherein the second and third axes are spaced apart along the lower portion in a direction parallel to the first axis, and wherein the inline wheels are located substantially centrally on the lower portion.

13. A suitcase as claimed in claim 12, wherein the suitcase has a first position in which the trolley wheels engage a surface, and in which the inline wheels are spaced from that surface, a second position in which the inline wheels engage a surface, and in which the trolley wheels are spaced apart from that surface.

14. A suitcase as claimed in claim 12, wherein the suitcase has a first position in which the trolley wheels engage a surface, and in which the inline wheels are spaced from that surface, a second position in which the inline wheels engage a surface, and in which the trolley wheels are spaced apart from that surface, and wherein the suitcase has an intermediate position in which neither the trolley wheels nor the inline wheels engage a surface.

15. A suitcase as claimed in claim 12, wherein the suitcase has a first position in which the trolley wheels engage a surface, and in which the inline wheels are spaced from that surface, a second position in which the inline wheels engage a surface, and in which the trolley wheels are spaced apart from that surface, and wherein the suitcase has an intermediate position in which the trolley wheels and the inline wheels engage a surface.

16. A suitcase as claimed in claim 12, further comprising: a storage box that defines a storage volume therein, the storage box being releasably located in the upper portion of the suitcase, and being removable from the upper portion of the suitcase when the closure member is in the first position.

17. A suitcase as claimed in claim 12, further comprising a storage box that defines a storage volume therein, the storage box being releasably located in the upper portion of the suitcase, and being removable from the upper portion of the suitcase when the closure member is in the first position, wherein the storage box includes a storage box body defining the storage volume, and a lid portion having a closed configuration in which the storage volume is closed, and an open configuration in which the storage volume is open.

18. A suitcase as claimed in claim 12, further comprising a storage box that defines a storage volume therein, the storage box being releasably located in the upper portion of the suitcase, and being removable from the upper portion of

the suitcase when the closure member is in the first position, wherein the storage box includes a storage box body defining the storage volume, and a lid portion having a closed configuration in which the storage volume is closed, and an open configuration in which the storage volume is open, wherein the lid is rotatably attached to the storage box body.

19. A suitcase as claimed in claim 12, further comprising a storage box that defines a storage volume therein, the storage box being releasably located in the upper portion of the suitcase, and being removable from the upper portion of the suitcase when the closure member is in the first position, wherein the storage box includes a storage box body defining the storage volume, and a lid portion having a closed configuration in which the storage volume is closed, and an open configuration in which the storage volume is open, wherein the lid is rotatably attached to the storage box body, wherein the lid is adapted to seal against the storage box body in the closed configuration, thereby substantially to prevent ingress of water into the storage volume of the storage box.

20. A suitcase as claimed in claim 12, further comprising a storage box that defines a storage volume therein, the storage box being releasably located in the upper portion of the suitcase, and being removable from the upper portion of the suitcase when the closure member is in the first position, wherein the storage box includes a storage box body defining the storage volume, and a lid portion having a closed configuration in which the storage volume is closed, and an open configuration in which the storage volume is open, wherein the lid of the storage box is adapted to provide a seat surface for a user.

21. A suitcase as claimed in claim 12, further comprising a storage box that defines a storage volume therein, the storage box being releasably located in the upper portion of the suitcase, and being removable from the upper portion of the suitcase when the closure member is in the first position, wherein the storage box includes a storage box body defining the storage volume, and a lid portion having a closed configuration in which the storage volume is closed, and an open configuration in which the storage volume is open, the suitcase further comprising retaining means for retaining the storage box in the upper portion of the case body.

22. A suitcase as claimed in claim 12, further comprising a storage box that defines a storage volume therein, the storage box being releasably located in the upper portion of the suitcase, and being removable from the upper portion of the suitcase when the closure member is in the first position, wherein the storage box includes a storage box body defining the storage volume, and a lid portion having a closed configuration in which the storage volume is closed, and an open configuration in which the storage volume is open, the suitcase further comprising retaining means for retaining the storage box in the upper portion of the case body, wherein retaining means includes a resiliently biased member.

23. A suitcase as claimed in claim 12, further comprising a storage box that defines a storage volume therein, the storage box being releasably located in the upper portion of the suitcase, and being removable from the upper portion of the suitcase when the closure member is in the first position, wherein the storage box includes a storage box body defining the storage volume, and a lid portion having a closed configuration in which the storage volume is closed, and an open configuration in which the storage volume is open, the

suitcase further comprising locking means for locking the storage box in the upper portion of the case body.

24. A suitcase as claimed in claim **12**, further comprising a storage box that defines a storage volume therein, the storage box being releasably located in the upper portion of the suitcase, and being removable from the upper portion of the suitcase when the closure member is in the first position, wherein the storage box includes a storage box body defining the storage volume, and a lid portion having a closed configuration in which the storage volume is closed, and an open configuration in which the storage volume is open, the suitcase further comprising locking means for locking the storage box in the upper portion of the case body, wherein locking means includes a resiliently biased member.

25. A suitcase as claimed in claim **1**, wherein the lower portion is integrated with the side portions and/or front and/or rear portions.

26. A suitcase as claimed in claim **1**, wherein the lower portion is removable from the side portions, and/or front and/or rear portions.

27. A suitcase as claimed in claim **12**, wherein the lower portion is integrated with the side portions and/or front and/or rear portions.

28. A suitcase as claimed in claim **12**, wherein the lower portion is removable from the side portions, and/or front and/or rear portions.

* * * * *