

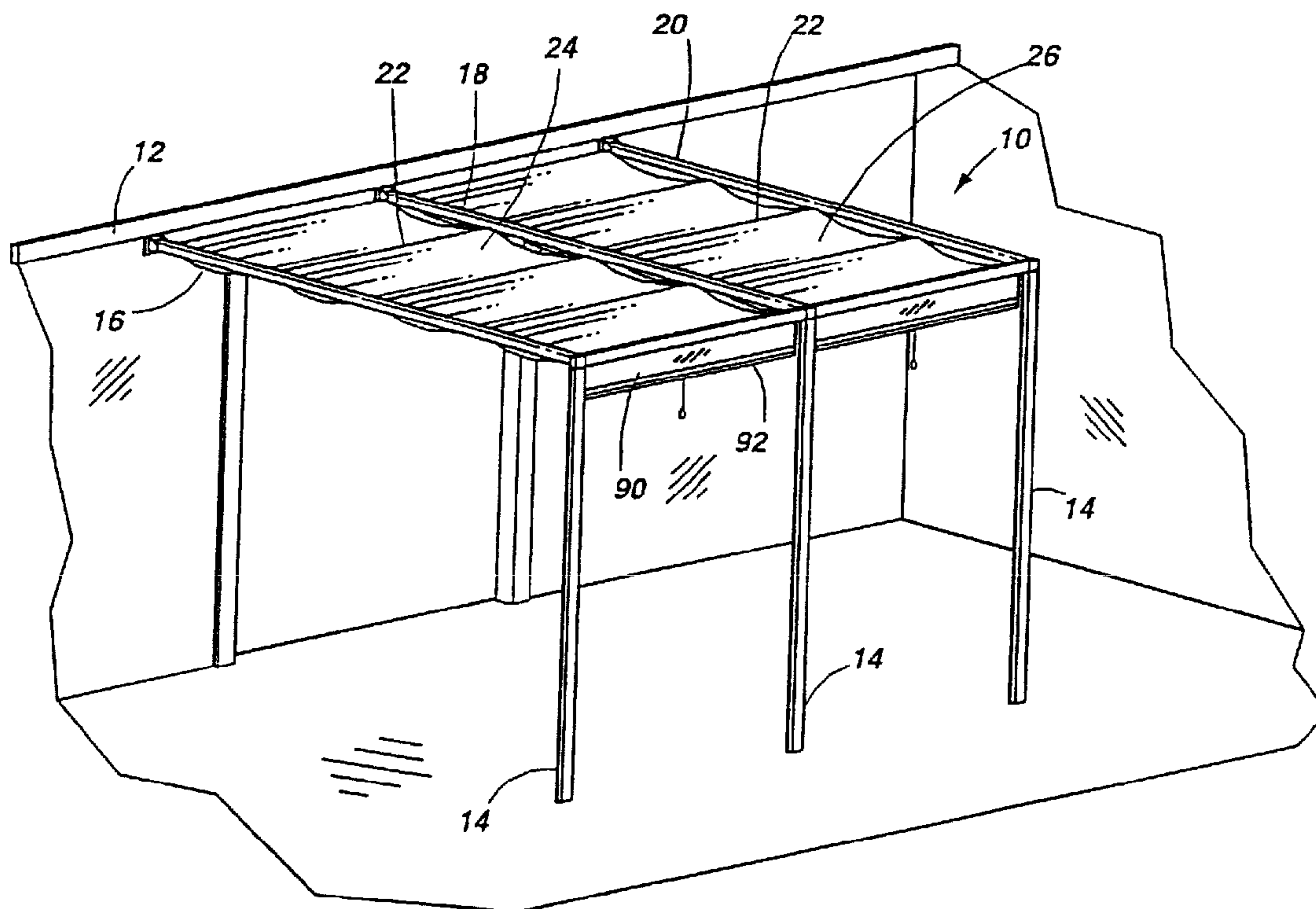

(86) Date de dépôt PCT/PCT Filing Date: 1998/01/09
 (87) Date publication PCT/PCT Publication Date: 1998/07/23
 (45) Date de délivrance/Issue Date: 2006/06/06
 (85) Entrée phase nationale/National Entry: 1999/07/15
 (86) N° demande PCT/PCT Application No.: US 1998/000650
 (87) N° publication PCT/PCT Publication No.: 1998/031912
 (30) Priorité/Priority: 1997/01/15 (US08/784,256)

(51) Cl.Int./Int.Cl. *E06B 3/94* (2006.01),
E04F 10/06 (2006.01), *E04F 10/02* (2006.01),
E06B 9/262 (2006.01)
 (72) Inventeurs/Inventors:
 WILLIAMS, MARVIN E., US;
 TARTARON, JOSEPH R., US
 (73) Propriétaire/Owner:
 SHADETREE SYSTEMS LLC, US
 (74) Agent: RICHES, MCKENZIE & HERBERT LLP

(54) Titre : STRUCTURE POUR ABRI PARE-SOLEIL
 (54) Title: CANOPY STRUCTURE FOR SUN SHADE



(57) **Abrégé/Abstract:**

A shade canopy structure (10) has several substantially parallel, but laterally spaced rafter members (16, 18, 20), each rafter member (16, 18, 20) having longitudinally extending tracks (30, 32) on its laterally opposite sides. The rafters define a plurality of laterally spaced openings. A plurality of cross beams (22) extend laterally between adjacent rafter members (16, 18, 20) and have their ends engaged in the track (30, 32) for sliding along the track. This forces a plurality of laterally spaced tiers of cross beams (22) for each of the laterally spaced openings. A plurality of flexible, laterally spaced opaque sheets (24, 26), each are extendible along one of the laterally spaced openings and each is attached to a tier of cross beams (22) at spaced locations along the sheet (24, 26) so that each sheet (24, 26) may be independently drawn to an extended position and releasably latched in an extended position, or manually withdrawn to a retracted position.

PCT

WORLD INTELLECTUAL PROPERTY ORGANIZATION
International Bureau

INTERNATIONAL APPLICATION PUBLISHED UNDER THE PATENT COOPERATION TREATY (PCT)

<p>(51) International Patent Classification ⁶ : E06B 3/94</p>	A1	<p>(11) International Publication Number: WO 98/31912</p> <p>(43) International Publication Date: 23 July 1998 (23.07.98)</p>
<p>(21) International Application Number: PCT/US98/00650</p> <p>(22) International Filing Date: 9 January 1998 (09.01.98)</p> <p>(30) Priority Data: 08/784,256 15 January 1997 (15.01.97) US</p> <p>(71) Applicant: MARVINGARDENS, LTD. [US/US]; 6393 Busch Boulevard, Columbus, OH 43229 (US).</p> <p>(72) Inventors: WILLIAMS, Marvin, E.; 1318 Brairmeadow Drive, Columbus, OH 43215 (US). TARTARON, Joseph, R.; 1441 Haines Avenue, Columbus, OH 43212 (US).</p> <p>(74) Agent: FOSTER, Frank, H.; Kremblas, Foster, Millard & Pollick, 7632 Slate Ridge Boulevard, Reynoldsburg, OH 43068 (US).</p>		<p>(81) Designated States: AL, AM, AT, AU, AZ, BA, BB, BG, BR, BY, CA, CH, CN, CU, CZ, DE, DK, EE, ES, FI, GB, GE, GH, GM, GW, HU, ID, IL, IS, JP, KE, KG, KP, KR, KZ, LC, LK, LR, LS, LT, LU, LV, MD, MG, MK, MN, MW, MX, NO, NZ, PL, PT, RO, RU, SD, SE, SG, SI, SK, SL, TJ, TM, TR, TT, UA, UG, UZ, VN, YU, ZW, ARIPO patent (GH, GM, KE, LS, MW, SD, SZ, UG, ZW), Eurasian patent (AM, AZ, BY, KG, KZ, MD, RU, TJ, TM), European patent (AT, BE, CH, DE, DK, ES, FI, FR, GB, GR, IE, IT, LU, MC, NL, PT, SE), OAPI patent (BF, BJ, CF, CG, CI, CM, GA, GN, ML, MR, NE, SN, TD, TG).</p> <p>Published <i>With international search report.</i></p>

(54) Title: CANOPY STRUCTURE FOR SUN SHADE

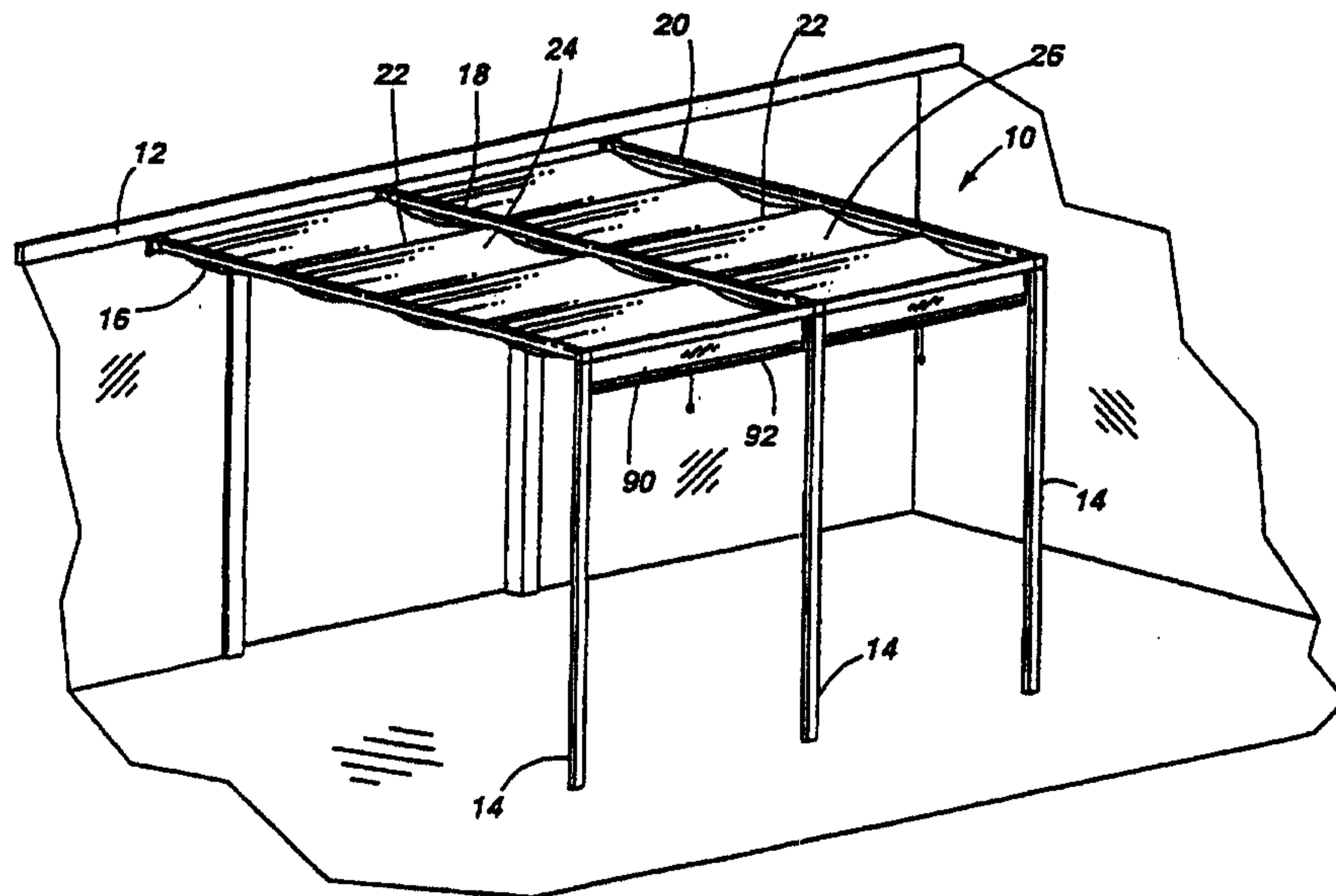

(57) Abstract

A shade canopy structure (10) has several substantially parallel, but laterally spaced rafter members (16, 18, 20), each rafter member (16, 18, 20) having longitudinally extending tracks (30, 32) on its laterally opposite sides. The rafters define a plurality of laterally spaced openings. A plurality of cross beams (22) extend laterally between adjacent rafter members (16, 18, 20) and have their ends engaged in the track (30, 32) for sliding along the track. This forms a plurality of laterally spaced tiers of cross beams (22) for each of the laterally spaced openings. A plurality of flexible, laterally spaced opaque sheets (24, 26), each are extendible along one of the laterally spaced openings and each is attached to a tier of cross beams (22) at spaced locations along the sheet (24, 26) so that each sheet (24, 26) may be independently drawn to an extended position and releasably latched in an extended position, or manually withdrawn to a retracted position.

TITLE: CANOPY STRUCTURE FOR SUN SHADE

Technical Field

5 This invention relates generally to building structures, and more particularly relates to an inexpensive sun shading structure for use over patios, decks, porches, and the like.

Background Art

10 For human health, as well as human comfort, it is desirable to provide a sun shade above many outdoor living and recreational areas. Such areas include the porches of apartments and condominiums, decks, areas near swimming pools, outdoor restaurants, and other outdoor commercial areas. In warm seasons and in warm climates, on cloudless days, the bright sunlight can make an outdoor area extremely uncomfortable or uninhabitable, particularly where the area has a southern or western exposure. Although trees and other vegetation can provide natural shade, in many areas, particularly areas of recent construction, such vegetation is too small to provide practical shade.

20 There are a variety of products readily available which attempt to solve this problem. Most, however, are expensive because they include sophisticated mechanisms to enable them to be completely retracted for providing overhead exposure

25

on non-sunny days. The sophisticated mechanical mechanisms typically require precise alignment and adjustment, and require expensive maintenance if they become misaligned. Most prior art overhead shading structures have only a limited or no ability to permit the user to fully or only partially retract selected portions in order to tailor the shaded area to the user's needs at a specific time of day and sun position. Some prior art structures require that a contractor be employed to construct a wooden overhead support structure. There are also considerably less expensive shade structures, but these are permanent awnings or metallic roofs which cannot be moved to accommodate different weather conditions. Essentially all of these prior art systems require the employment of a contractor or experienced installation professional in order to insure that they are properly installed. This, however, increases the cost of such units.

As a consequence, there is a need for a shade canopy structure which combines the features of being inexpensive, yet strong and sturdy, while also being sufficiently simple and easy to install that it can be installed by do-it-yourself home owners. There is also a need for a canopy which permits the user to tailor the shape and size of the shade area to accommodate the user's layout of furniture and other objects for any desired sun and weather conditions. There is also a need for a canopy shade structure which does not require custom manufacturing, but rather is capable of being constructed from standard components in multiple, modular units so that it can be inexpensively custom fit to essentially any size outdoor area of human habitation. There is also a need for a shade canopy

structure which can be very simply and easily manually retracted or extended without requiring complicated mechanisms for winding the shade fabric on a roll and unwinding it.

5 The prior art illustrates a variety of door and window shading structures having spaced crossbars attached along a ribbon of fabric, with the crossbars sliding in a track on each side of the door or window. Such structures are shown, for
10 example, in U.S. Patents 4,647,488; 4,776,379; 5,379,823; and 5,503,210. These devices extend between opposite door sides, to span across a single opening required for a door.

 U.S. Patent 5,026,109 shows a similar concept
15 applied to cover the cargo bin portion of a truck. That structure utilizes a rope and pulley mechanism for retracting and extending the cover. U.S. Patent 1,713,452 shows similar concepts applied to a single window shade.

20 U.S. Patent 1,106,624 shows a partial shade system for orchards which relies upon a plurality of side-by-side ribbons, each ribbon being an at least partially transparent fabric, which is supported by horizontally stretched ropes and rolled up on the
25 ends. While this system allows a selectable contouring of the shaded area, it also requires rolling mechanisms and intermediate ropes to hold it down between the posts. Furthermore, its shade has intermittent, unshaded areas between the fabric
30 ribbons and the tensioning of the support ropes causes the vertical posts to be pulled toward the center, and eventually become tilted in a non-vertical, unsightly orientation.

Brief Disclosure Of Invention

The invention is a canopy structure comprising at least three substantially parallel, laterally spaced rafter members which form a plurality of laterally spaced openings. Each rafter member has a pair of longitudinally extending tracks on laterally opposite sides of the rafter member. A plurality of movable cross beams extend laterally between adjacent rafter members, and each cross beam has a track engaging member attached to each end, which is slidable along the track. In this manner, the invention forms a plurality of laterally spaced tiers of cross beams. Each tier of cross beams includes a flexible, opaque sheet between and extending longitudinally along the rafters. Each sheet is attached to the cross beams at spaced locations along the sheet. Preferably, there are end locks near each end of the rafter members which engage the endmost cross beams when the flexible sheets are fully extended. The end locks retain the endmost cross beams in position to retain the sheets in an outstretched tension, rather than permitting them to droop in large pleats between the cross beams. The end lock at one end may be permanently attached to the endmost cross beam at one end, while the end lock at the opposite end is releasable so that the sheets may be retracted by the user or automatically released in high wind conditions. The invention also includes several other preferred structural features.

In one aspect, the present invention provides a canopy comprising: a) at least three, substantially parallel, laterally spaced rafter members forming a plurality of laterally spaced openings between the rafter members, each rafter member having longitudinally extending tracks on laterally opposite sides; (b) a plurality of movable cross beams extending laterally between adjacent rafter members, each cross beam having a track engaging member attached to each end and slidable along the track; (c) a plurality of flexible, laterally spaced opaque sheets between and

4a

extending longitudinally along the rafters, each sheet attached to the cross beam at spaced locations along the sheet; and (d) an end lock near at least one end of each track for retaining an endmost cross beam in position when the sheet to which the cross beam is attached is tensioned to straighten the sheet.

In another aspect, the present invention provides a canopy comprising: (a) at least three, substantially parallel, laterally spaced rafter members forming a plurality of laterally spaced openings between the rafter members, each rafter member having longitudinally extending tracks on laterally opposite sides; (b) a plurality of movable cross beams extending laterally between adjacent rafter members, each cross beam having a track-engaging member attached to each end and slidable along the track wherein each cross beam is tubular and each track-engaging member comprises; (i) a sleeve having a finger portion frictionally engaging the interior end of a tubular beam, a bore parallel to the tubular beam, an annular shoulder extending beyond the periphery of the tubular beam, and an overhang extending over an end of the channel-shaped sheet clamp; (ii) a wheel at the lateral, outer end of the sleeve; and (iii) an elongated axle attached to the wheel and extending through the hole, the axle being freely, axially slidably through the bore of the sleeve, the axle having an enlarged interior end for retaining the axle in the bore; and (c) a plurality of flexible, laterally spaced opaque sheets between and extending longitudinally along the rafters, each sheet attached to the crossbeam at spaced locations along the sheet.

Brief Description Of Drawings

Fig. 1 is a view in perspective of an embodiment of the invention.

Fig. 2 is an exploded view in perspective

illustrating the rigid frame members of the present invention.

Fig. 3 is a view in perspective similar to Fig. 2 illustrating an alternative embodiment of the rafter member of Fig. 2 for extending the rafter member.

Fig. 4 is an exploded view in perspective illustrating the cooperation of the rafter members, cross beams, sheet material, and track engaging member of the present invention.

Fig. 5 is a view in vertical section taken substantially along the line 5-5 of Fig. 4, illustrating the cooperative engagement of the rafter member, the cross beam and its track engaging member.

Fig. 6 is a view in perspective of the sleeve component of the track engaging structures.

Fig. 7 is a view in perspective of a fixed end lock.

Fig. 8 is a view in perspective of an edge member for clamping to the end of each opaque sheet.

Fig. 9 is a view in perspective showing a releasable end lock mounted to the track of a rafter member.

Fig. 10 is a view in perspective of the end lock of Fig. 9.

Fig. 11 is a view in perspective of an edge member having alternative ball detents for seating in sockets formed at the end of the rafter members.

Fig. 12 is a view in perspective of an extender having a socket.

In describing the preferred embodiment of the invention which is illustrated in the drawings, specific terminology will be resorted to for the

sake of clarity. However, it is not intended that the invention be limited to the specific terms so selected and it is to be understood that each specific term includes all technical equivalents which operate in a similar manner to accomplish a similar purpose.

Detailed Description

Fig. 1 illustrates a canopy 10 embodying the present invention and mounted at one end to a building structure 12 and at its opposite end to vertical support posts 14. The frame portion of the canopy includes at least three substantially parallel, laterally spaced rafter members 16, 18 and 20, which are secured to the building structure 12 and to the posts 14. A plurality of movable cross beams 22 extend laterally between adjacent rafter members. Attached to each tier of cross beams, between each adjacent pair of rafter members, is a flexible opaque sheet, such as sheets 24 and 26, attached to the cross beams 22 at spaced intervals along the sheets 24 and 26. These laterally spaced sheets 24 and 26 provide the protective shade or sunscreen.

Fig. 2 shows details of the rigid frame structure of the present invention. Each rafter member, such as the rafter member 16, has longitudinally extending tracks 30 and 32, extending on laterally opposite sides of the rafter member 16. The preferred frame members, and particularly the rafter members, are each formed in a unitary construction of extruded aluminum. The tracks 30 and 32 engage the ends of adjacent sheet-supporting cross beams. The preferred rafter member is also formed with a utility track 34 along its underside

to support unrelated items, such as lighting and lighting wires, plants or other decorations. The tracks for supporting the cross beams may alternatively be located along the bottom surface of the rafter member 16 on laterally opposite sides of the bottom portion of the rafter member, although this is not preferred.

The rafter member 16 is preferably connected in a hinged or pivotal manner at each of its ends. For example, the rafter member 16 is hingedly attached to a wall surface bracket 36 by a bolt or pin 38 so the rafter member can pivot relative to the bracket. The opposite end is connected to a frame joining bracket 40 for pivotal movement by the pin 42 extending through ears 44 and holes 46 at the end of rafter member 16.

This pivotal connection permits the canopy to be mounted at a slope inclined to horizontal at the precise angle which is both desired by the user and accommodates the building structure to which it is mounted. A fixed cross beam 48 provides lateral rigidity for supporting the rafter members and presents a finished end appearance. The fixed cross beam 48 is also provided with a utility track on its opposite sides, such as utility track 49, and one on the opposite side (not visible). Similar utility tracks 51 and 53 are additionally provided on opposite sides of the posts 14. These utility tracks allow for future support of lighting, flower pots and other decorative items, as well as shades, valences or other accessories.

Fig. 3 illustrates an alternative structure for mounting the building structure end of the rafter member 16. This alternative uses an extender 50 which is pivotally mounted to the bracket 52 by a

pin 54. The extender 50 is slidable within the rafter member 16 and is secured to it by a screw (not shown) engaged in aligned holes in the underside of the rafter member 16 and the extender 50. This permits the end of the rafter member 16 to be spaced from the building in order to accommodate variations in the contour of the building structure to which the rafter members are to be attached.

Figs. 4 and 5 illustrate the rafter member 16 and the cross beam structures which engage it. The preferred cross beam 22 is a metal or plastic tube. Each end of each cross beam 22 has a track engaging member 60. The track engaging member includes a sleeve 62, which is also illustrated in more detail in Fig. 6. The sleeve 62 has a finger portion 64 which frictionally engages the interior end of the tubular cross beam 22. A bore 66 parallel to the tubular beam, and preferably coaxial with it, is formed through the finger portion 64. The sleeve 62 also has an annular shoulder 68 extending radially beyond the periphery of the tubular cross beam 22 and an overhang 70 which is backturned to extend over an end of a channel-shaped sheet clamp 72.

The sheet clamp 72 attaches the sheet 24 to the cross beam 22. Each sheet clamp 72 is a resilient, channel-shaped clamp which partially surrounds a cross beam and resiliently clamps the sheet between the cross beam and the clamp. Preferably the cross beam 22 is a cylindrical tube and the channel-shaped clamp is a partial tube of larger radius. The clamp 72 extends matingly more than 180° around the cylindrical, peripheral surface of the cross beam 22 so that the clamp will be resiliently expanded outwardly when forced over the sheet 24 and cross beam 22. This removably but snugly holds the sheet

in position on the cross beam. The inside diameter of the clamp 72 is approximately the same as the outside diameter of the tubular cross beam 22. Preferably the clamp 72 is provided with a longitudinal, protruding ridge 74 which seats in a corresponding slot 76 in the sleeve 62 for properly aligning the clamp 72 and preventing it from sliding rotationally around the cross beam 22.

The track engaging member further includes a wheel 80 located at the outer end of the sleeve 62 for engagement within the track 30. The wheel 80 is mounted to an axle 82 which extends through the hole 66 in the sleeve 60. Although the wheel can be journalled to the axle in a conventional structure, preferably the wheel 80 is formed as a unitary body along with the axle 82, and is molded synthetic resin such as glass filled nylon. The diameter of the axle 82 is made sufficiently smaller than the sleeve bore 66 so that the axle is free to both rotate within and slide axially or laterally with respect to the sleeve 62. The axle 82 is provided with an enlarged interior end 84 for retaining the axle in the bore. However, the axle is made sufficiently long that it can slide a considerable distance, for example 2 inches, within the sleeve 60. This lateral sliding of the axle assures that the wheel will not bind in the tracks, even when the cross beams 22 are located at a substantial oblique angle to a perpendicular extending between the rafter members. This also prevents binding in the event that the spacing of the rafter members is not uniform with the result that the rafter members depart significantly from perfectly parallel.

Preferably the interior end of the axle comprises a plurality of interiorly extending

fingers 86 and 88 and two fingers behind them which are hidden from view by them. Each finger has an outwardly extending, enlarged portion with an inclined end, each of which forms a segment of the enlargement 84 so that collectively they form the enlarged interior end of the axle. These fingers can conveniently be constructed by forming radial slots perpendicular to each other and extending axially into the end of the axle 82. In this manner the fingers are resiliently flexible and can deform inwardly to permit insertion of the axle 82 into the bore 66.

It is desirable that each sheet extend beyond the endmost cross beam so that the end will hang down and form an end curtain 90. The end curtain not only provides some vertical shading, but more importantly extends down to within convenient reach of a user. The end edge of the end curtain 90 is preferably provided with an edge member 92, illustrated in more detail in Fig. 8, which extends laterally across the end of the sheet 24 and is clamped to it to provide a hand grip. The edge member 92 has a finished appearance and distributes the tensile forces exerted on the end of the sheet 24 when the sheet is manually pulled into an extended or retracted position by the user.

It is desirable that each opaque sheet be anchored near one end of each rafter member, preferably the end nearest the building structure, when the canopy of the present invention is attached to such a building structure. For this purpose, a fixed end lock is illustrated in Fig. 7. The fixed end lock has an axle portion 100, similar to the axle 82 of Fig. 5, but instead of having a wheel has a rectangular slide 102 which slides along the track

and is fixed in position by a screw or other fastener, tightened through a threaded bore 104. This fixed end lock permits one endmost cross beam of each tier of cross beams to be slid into the
5 desired position at which the screw through an end lock at each end of the cross beam is tightened to retain each endmost cross beam in position. This screw can later be loosened to permit subsequent readjustment.

10 It is similarly desirable that the opposite endmost cross beams which are furthest from the building structure be held in position when the sheets are fully extended so that the sheets will extend between the cross beams in relatively shallow
15 waves, rather than deep, large pleats, and so that the sheets remain extended. To accomplish this, a releasable end lock 110, illustrated in Figs. 9 and 10, is mounted near at least one end of each track for retaining the endmost cross beam in the extended
20 position when the sheet to which the cross beam is attached is tensioned to straighten the sheet. This releasable end lock 110, illustrated in Figs. 9 and 10, has a channel formed between upstanding legs 112 and 114, which engage the exterior side of the track
25 32, and leg 116 which engages the interior side of track 32. The end lock 110 is adjustably positioned during installation and then retained in position by tightening down a screw 118, threadedly engaged in a bore through the releasable end lock 110 and
30 seating against the bottom of the track 32 in the same manner as the fixed end lock of Fig. 7 is anchored in position.

35 The end of the endmost cross beam is releasably held in the releasable end lock 110 by seating within a U-shaped channel, formed by a rigid leg

120, and a resilient leg 122 of spring material. The resilient leg 122 has an upturned detente portion 124 for engaging and retaining the cross beam and a ramp portion 126 which allows a cross beam to be forced into the channel, deflecting the resilient finger 122 until the cross beam seats in the bottom of the channel.

Preferably the resilience or spring constant of the resilient member 122 is selected to permit comfortable insertion by a user, to retain the sheet in position in normal wind conditions, and to permit the sheet to be withdrawn by larger forces exerted by more extreme wind conditions which could potentially damage the sheet material.

Preferably a second releasable end lock is also positioned near the fixed end lock at the opposite end of each track. The second releasable end lock permits the user to releasably latch the endmost cross beam of each sheet in a fully retracted position.

Figs. 11 and 12 illustrate alternative ball detents mounted to the ends of an edge member which is clamped to the end of an end curtain 136. The purpose of the detents 130 and 132 is to provide a first latch member which permits the entire opaque sheet to be drawn to its fully retracted position and the end curtain 136 to be pulled underneath all the pleats formed between the cross beams and then latched in position to form a supporting sling. The edge member can be pulled snugly against the pleats to support them in a raised position and the edge member is then held in that position by seating the detents of the edge member in a second latch member preferably formed by sockets mounted near the end of the rafter member. This feature holds the pleats at

a higher elevation so they do not obstruct any pivoting doors which might be located on the building structure below the end of the installed canopy 10 and provides a more aesthetic appearance.

5 Fig. 12 shows a socket 138 formed or mounted at the end of an extender 140 constructed similarly to the extender 50 illustrated in Fig. 3 and attached to a rafter member in the same manner. The socket 138 forms a cradle which receives and supports the
10 ball detent 130 and therefore the end edge member and end curtain attached to it. Of course, other attachment structures can be used to attach the edge member and suitable sockets or other attachment structures can alternatively be mounted directly to
15 the rafter members, for example by mounting them to the tracks formed on the rafter members.

The cross beams and the sheets mounted to them are freely slidable along the tracks of the rafter members. Therefore at least one of the cross beams
20 must be anchored to the track or at least one of the ends of each track must be blocked to prevent the sheets from being slid out the end of the track. The end locks perform this function.

The rafter members and their tracks can be
25 formed either in a curved contour or can be formed as a rafter having two linear components intersecting at an angle. This allows more end shade by creating a side or end curtain effect.

Embodiments of the present invention are
30 inexpensive to purchase and install because they utilize no sophisticated mechanisms, requiring no winding or rolling of the sheet material. To extend or retract the sheets, the user simply reaches up and grasps the edge member 92, which may
35 additionally be provided with a handle, and draws

each entire sheet, along with its attached cross beams, to whatever extension the user wishes. The user may position the sheet at any intermediate position or may draw it to a fully extended position and lock it in place into the releasable end locks.

5 An additional advantage of the present invention is that the sheet material requires no sewing or stitching and therefore eliminates these potentially expensive manual labor steps. Unlike other shade systems, embodiments of the present invention can utilize a sheet material of a standard width and does not require a plurality of ribbons of fabric or other sheet-like material to be sewn together or to be sewn to other supporting structures.

10 While certain preferred embodiments of the present invention have been disclosed in detail, it is to be understood that various modifications may be adopted without departing from the spirit of the invention or scope of the following claims.

20

CLAIMS

1. A canopy comprising:

a) at least three, substantially parallel, laterally spaced rafter members forming a plurality of laterally spaced openings between the rafter members, each rafter member having longitudinally extending tracks on laterally opposite sides;

(b) a plurality of movable cross beams extending laterally between adjacent rafter members, each cross beam having a track engaging member attached to each end and slidable along the track;

(c) a plurality of flexible, laterally spaced opaque sheets between and extending longitudinally along the rafters, each sheet attached to the cross beam at spaced locations along the sheet; and

(d) an end lock near at least one end of each track for retaining an endmost cross beam in position when the sheet to which the cross beam is attached is tensioned to straighten the sheet.

2. A canopy in accordance with claim 1 wherein the end lock is releasable in response to potentially destructive tension for providing wind damage protection.

3. A canopy in accordance with claim 1 wherein the previously recited end lock is fixed and a second, releasable end lock is mounted at the opposite end of each track and is releasable in response to potentially destructive tension for providing wind damage protection.

4. A canopy in accordance with any one of claims 1 to 3 wherein each track-engaging member comprises a rotatable wheel at the end of each cross beam mounted to an axle and which is axially slidable within the cross beam.

5. A canopy in accordance with any one of claims 1 to 3 wherein the sheets are attached to the cross beams by resilient, channel-shaped clamps, each clamp partially surrounding a cross beam and resiliently clamping a sheet between the cross beam and the clamp.
6. A canopy in accordance with claim 5 wherein each cross beam is tubular and each track-engaging member comprises:
- (a) a sleeve having a finger portion frictionally engaging the interior end of a tubular beam, a bore parallel to the tubular beam, an annular shoulder extending beyond the periphery of the tubular beam, and an overhang extending over an end of the channel-shaped sheet clamp;
 - (b) a wheel at the lateral, outer end of the sleeve; and
 - (c) an elongated axle attached to the wheel and extending through the hole, the axle being freely, axially slidably through the bore of the sleeve, the axle having an enlarged interior end for retaining the axle in the bore.
7. A canopy in accordance with claim 6 wherein the interior end of the axle comprises a plurality of interiorly extending fingers, each finger having an outwardly extending enlarged portion to collectively form the enlarged interior end of the axle, each finger being resiliently flexible to deform inwardly to permit insertion of the axle through the bore.
8. A canopy in accordance, with claim 1 further comprising hinged mounting brackets connected to the longitudinally opposite ends of the rafter members for pivotally mounting the rafter members to vertical supports.
9. A canopy in accordance with claim 1 or claim 8 wherein the sheet extends beyond an endmost cross beam and an end

edge member is attached laterally across the end of the sheet for hanging freely downwardly below the rafter members.

10. A canopy in accordance with claim 9 wherein a first latch member is formed near the ends of the edge member and a second latch member is mounted near an end of the rafter member for removably supporting the edge member and the curtain portion beneath and supporting pleats of the opaque sheet.

11. A canopy in accordance with claim 10 wherein the first latch member is a detent and the second latch member is a socket for removably receiving the detent.

12. A canopy in accordance with claim 11 wherein the detent is a ball detent.

13. A canopy comprising:

(a) at least three, substantially parallel, laterally spaced rafter members forming a plurality of laterally spaced openings between the rafter members, each rafter member having longitudinally extending tracks on laterally opposite sides;

(b) a plurality of movable cross beams extending laterally between adjacent rafter members, each cross beam having a track-engaging member attached to each end and slidable along the track wherein each cross beam is tubular and each track-engaging member comprises;

(i) a sleeve having a finger portion frictionally engaging the interior end of a tubular beam, a bore parallel to the tubular beam, an annular shoulder extending beyond the periphery of the tubular beam, and an overhang extending over an end of the channel-shaped sheet clamp;

(ii) a wheel at the lateral, outer end of the sleeve; and

(iii) an elongated axle attached to the wheel and extending through the hole, the axle being freely, axially slidably through the bore of the sleeve, the axle having an enlarged interior end for retaining the axle in the bore; and

(c) a plurality of flexible, laterally spaced opaque sheets between and extending longitudinally along the rafters, each sheet attached to the crossbeam at spaced locations along the sheet.

14. A canopy in accordance with claim 13 wherein the interior end of the axle comprises a plurality of interiorly extending fingers, each finger having an outwardly extending enlarged portion to collectively form the enlarged interior end of the axle, each finger being resiliently flexible to deform inwardly to permit insertion of the axle through the bore.

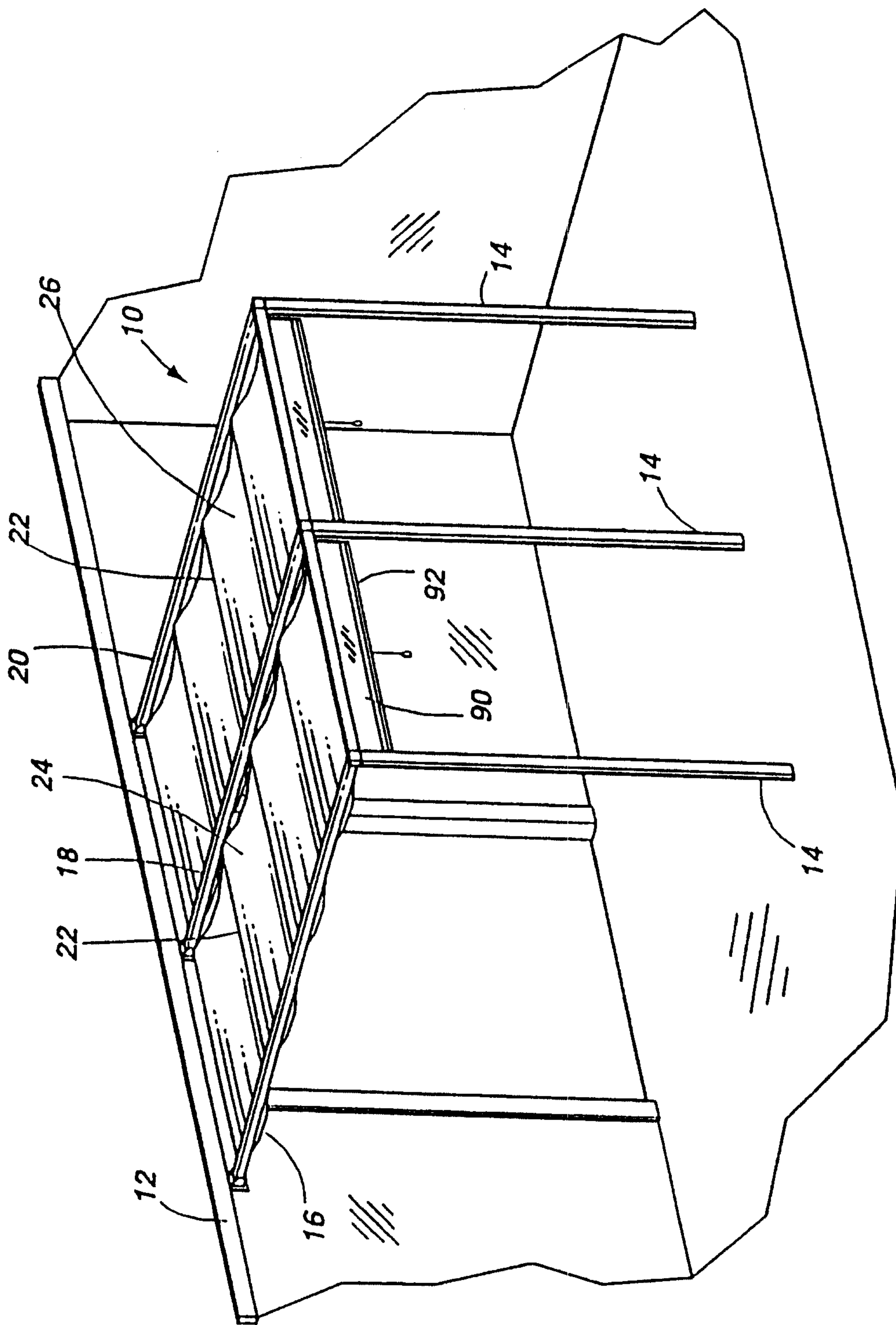

Fig. 1

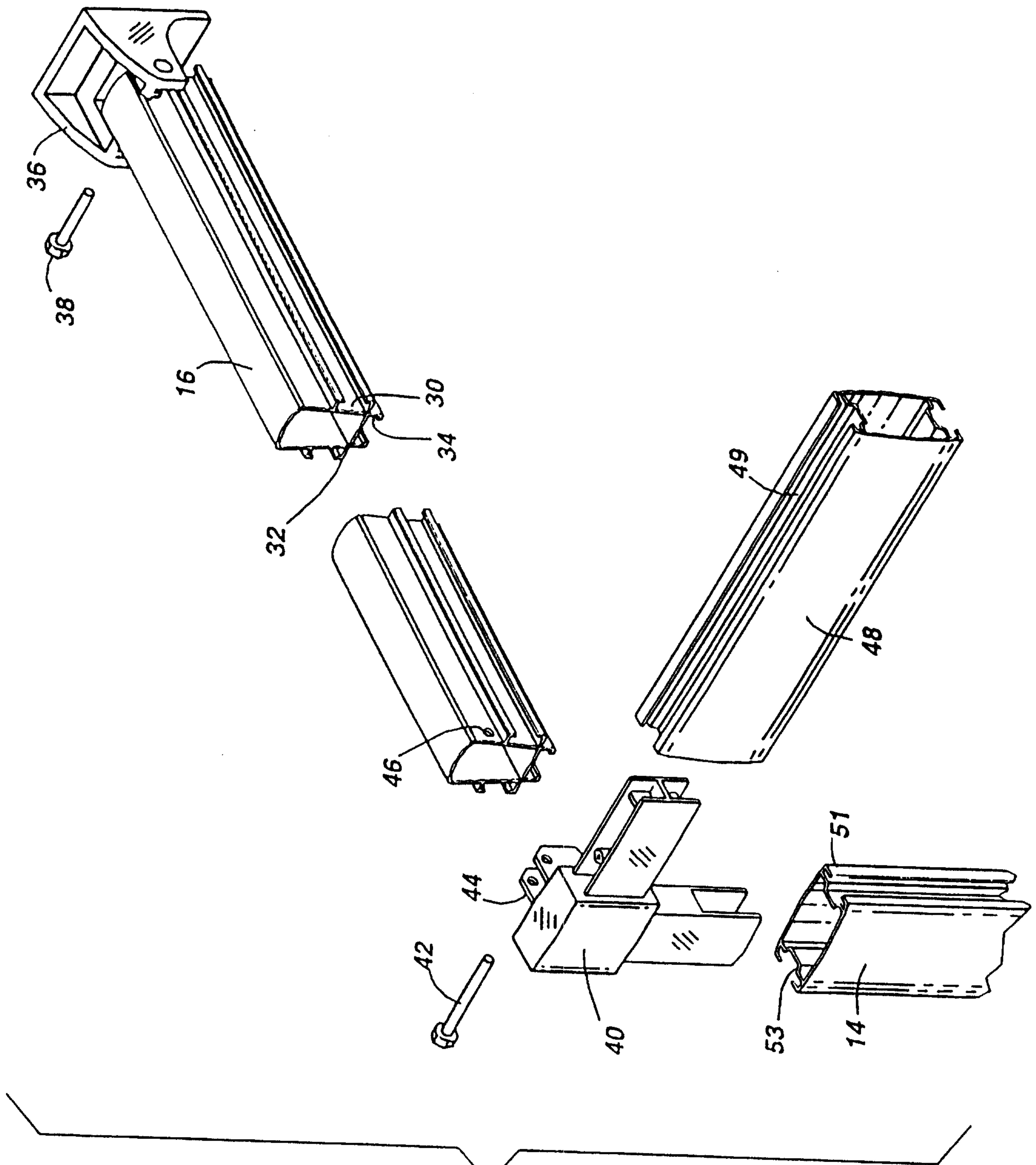

Fig. 2

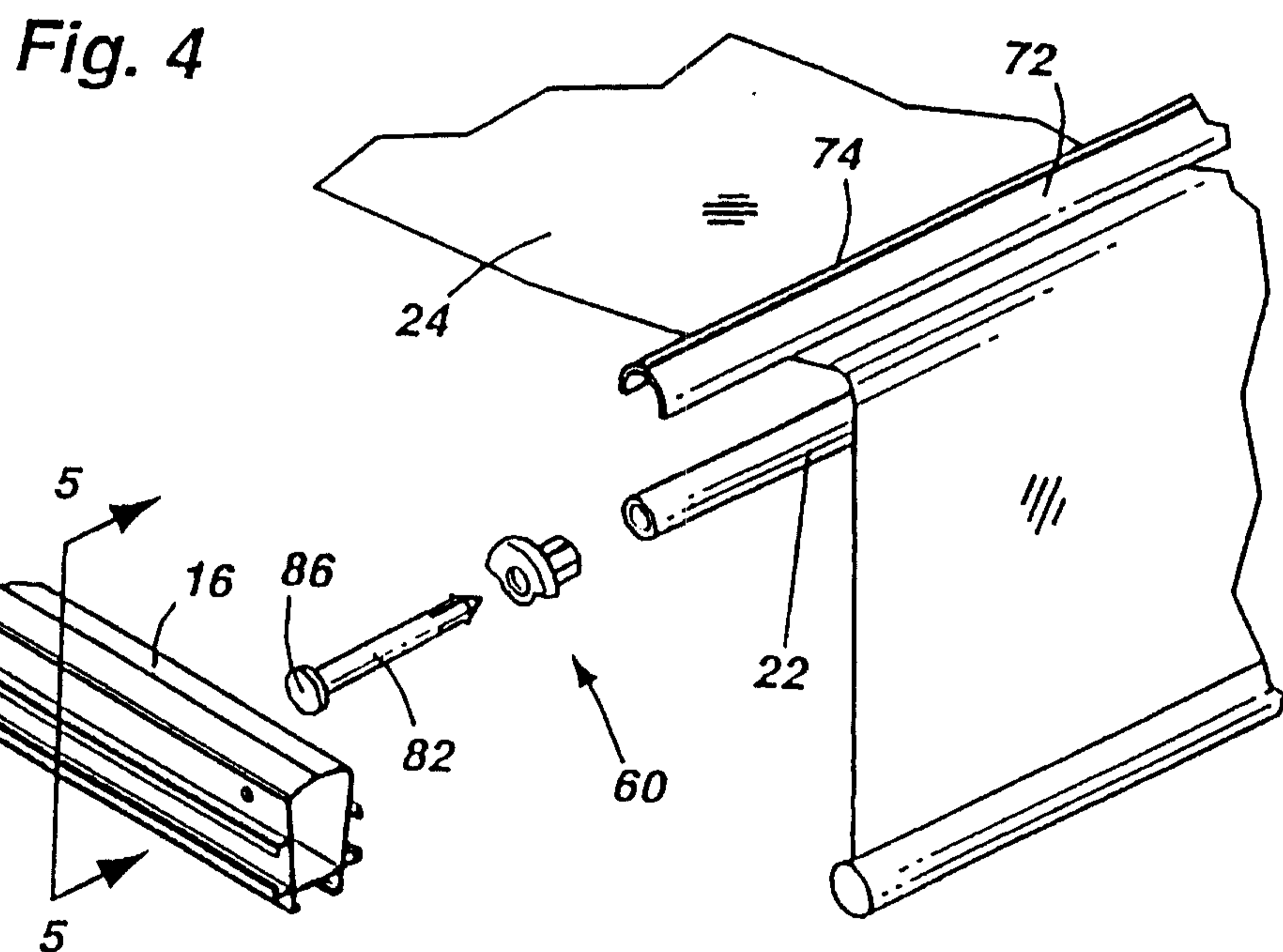
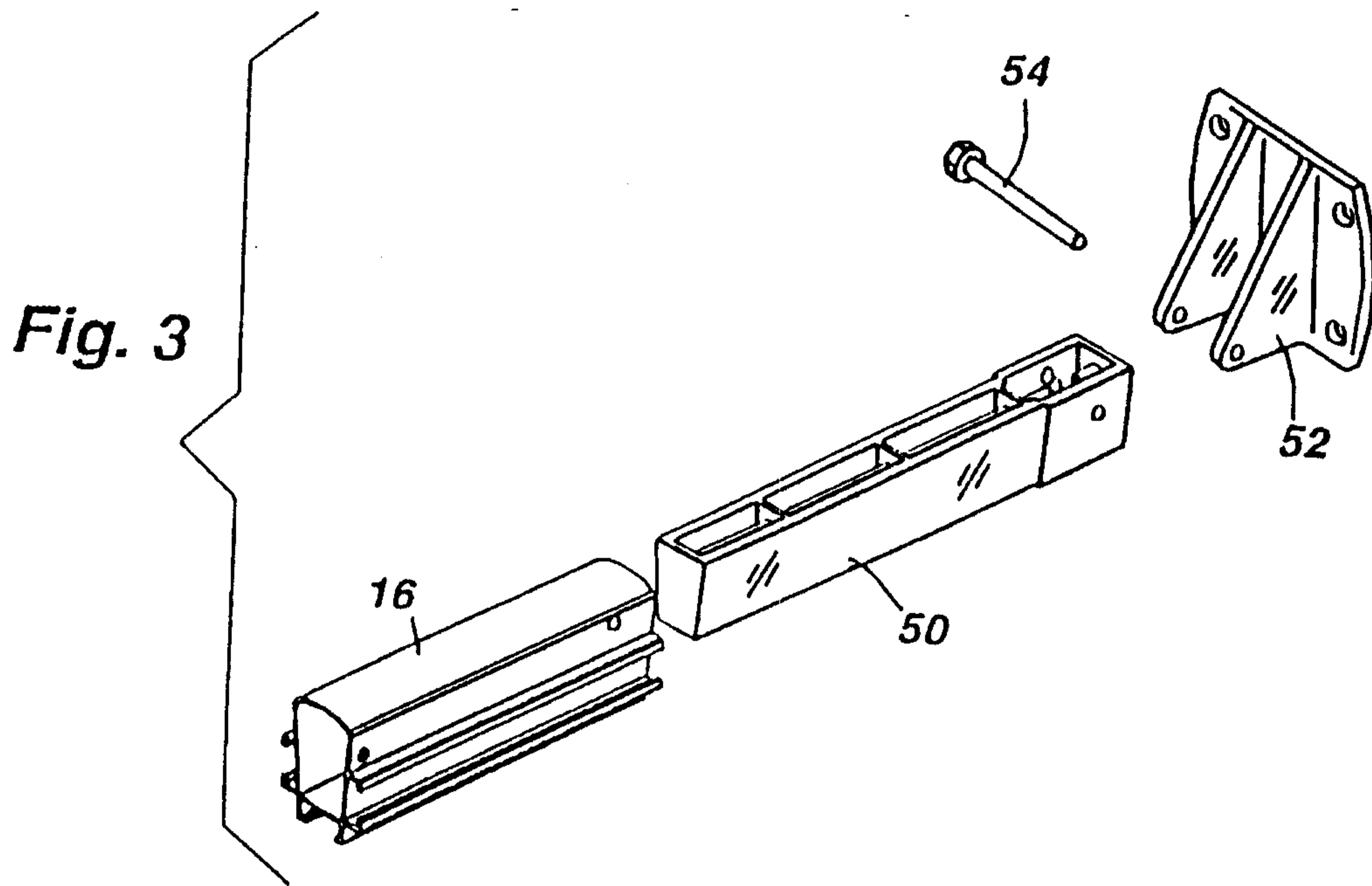

Fig. 5

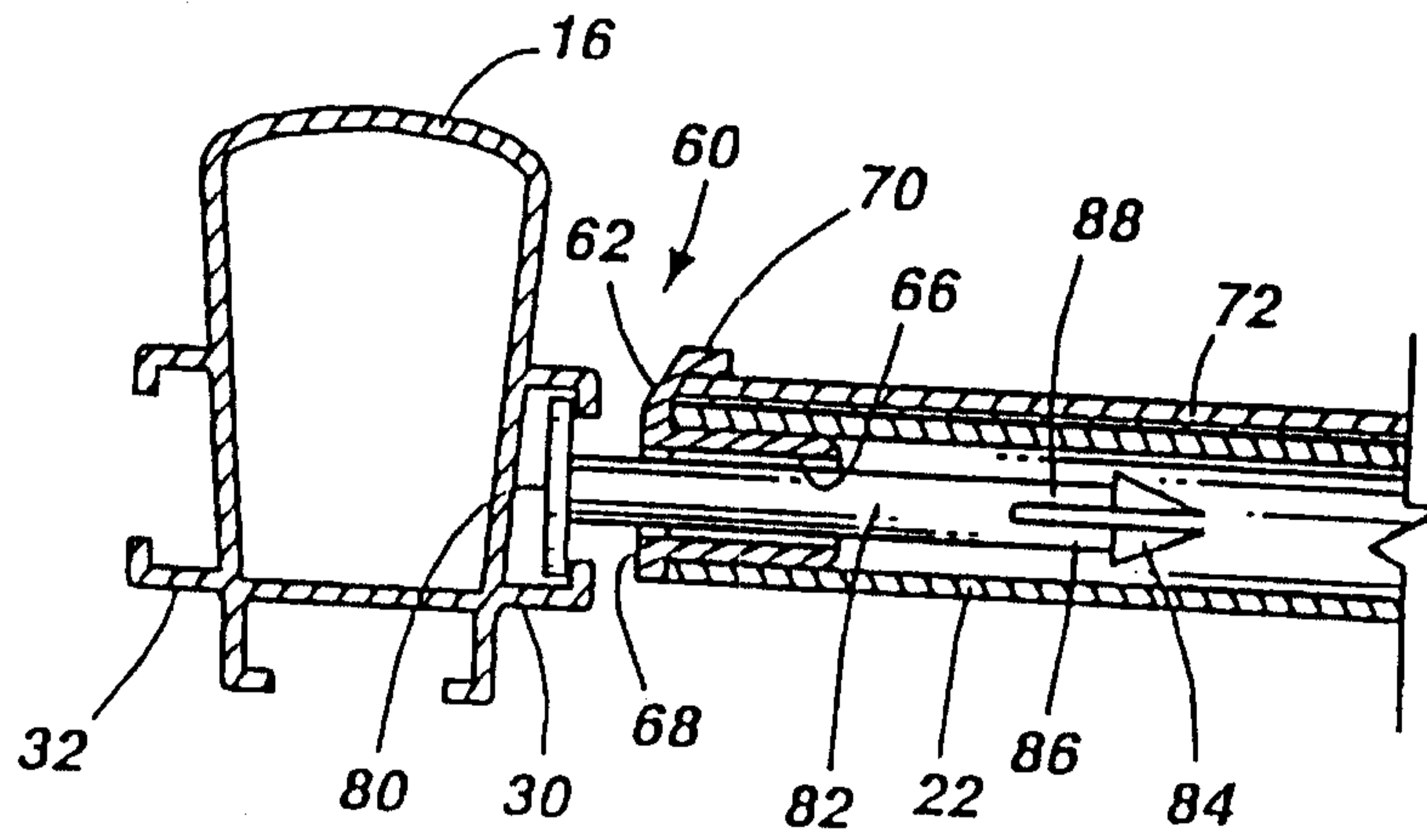

Fig. 6

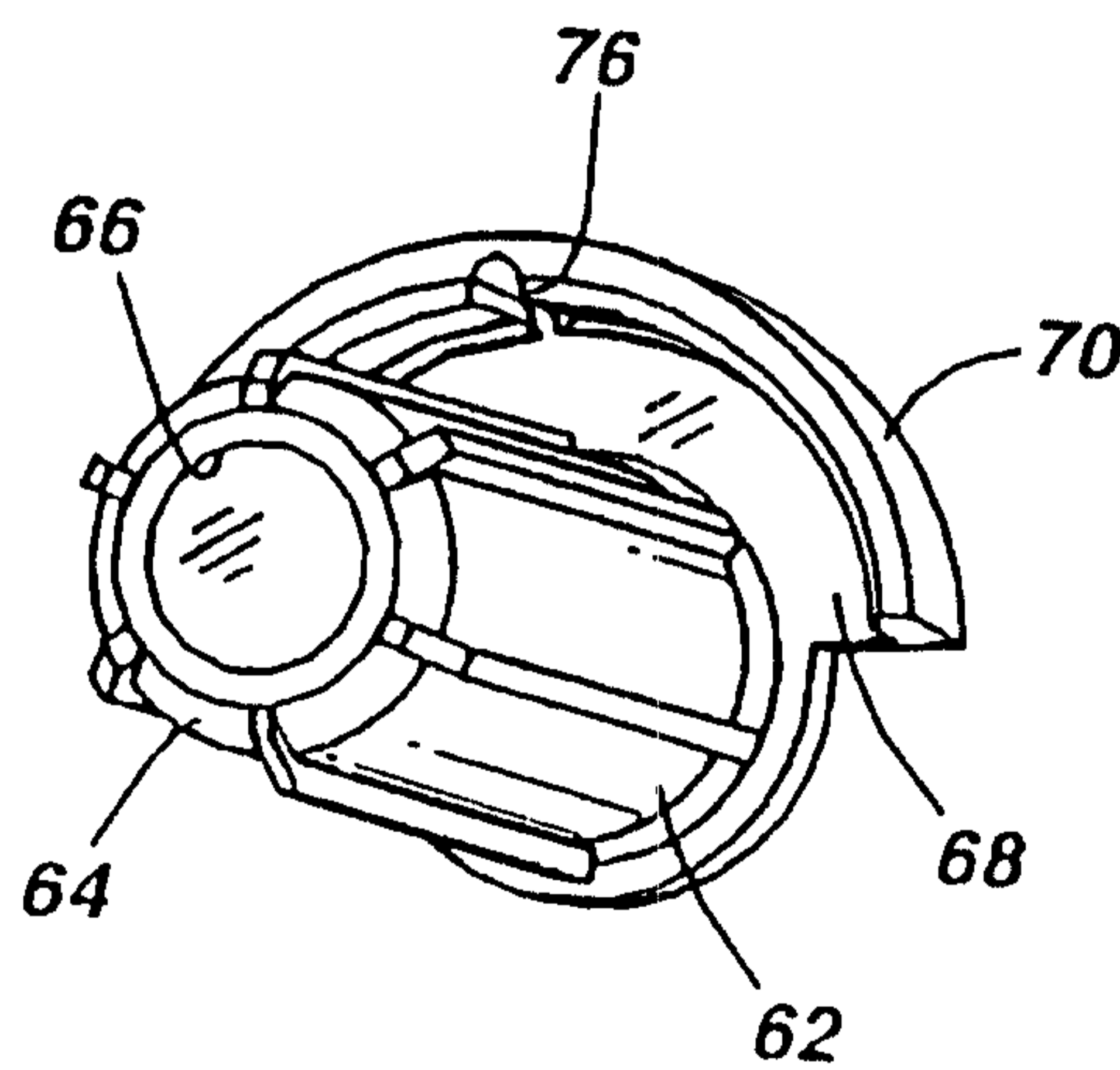

Fig. 7

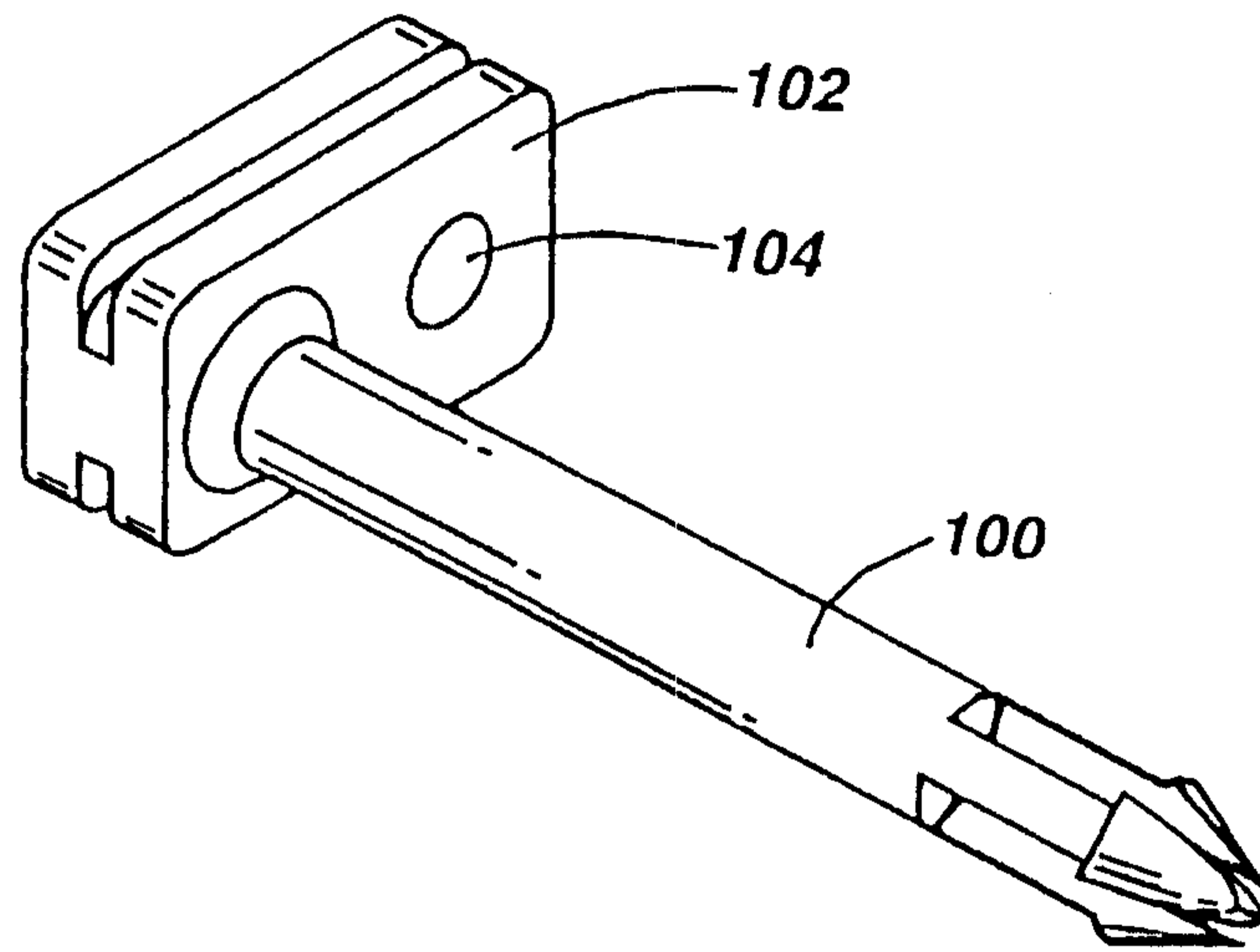

Fig. 8

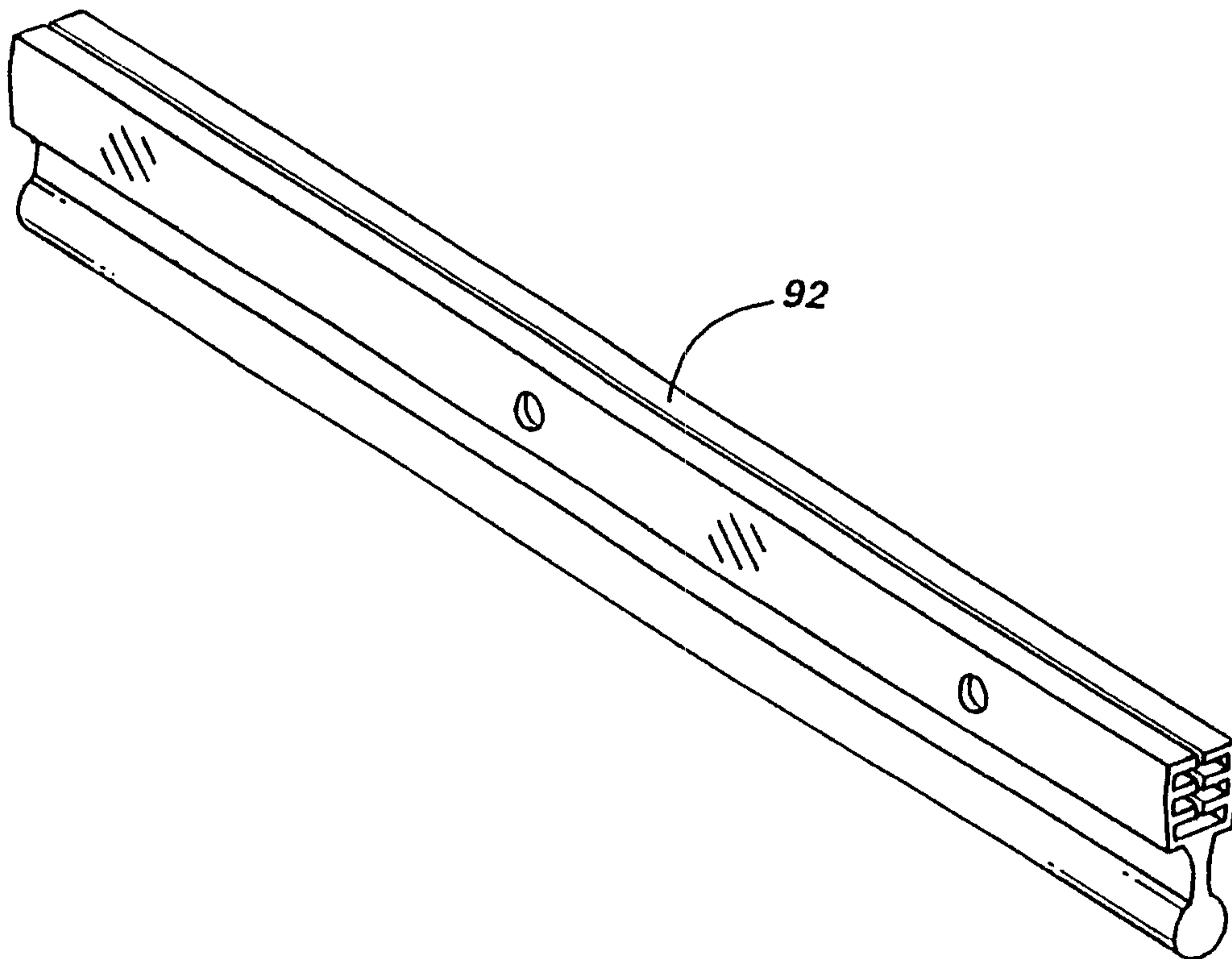

Fig. 9

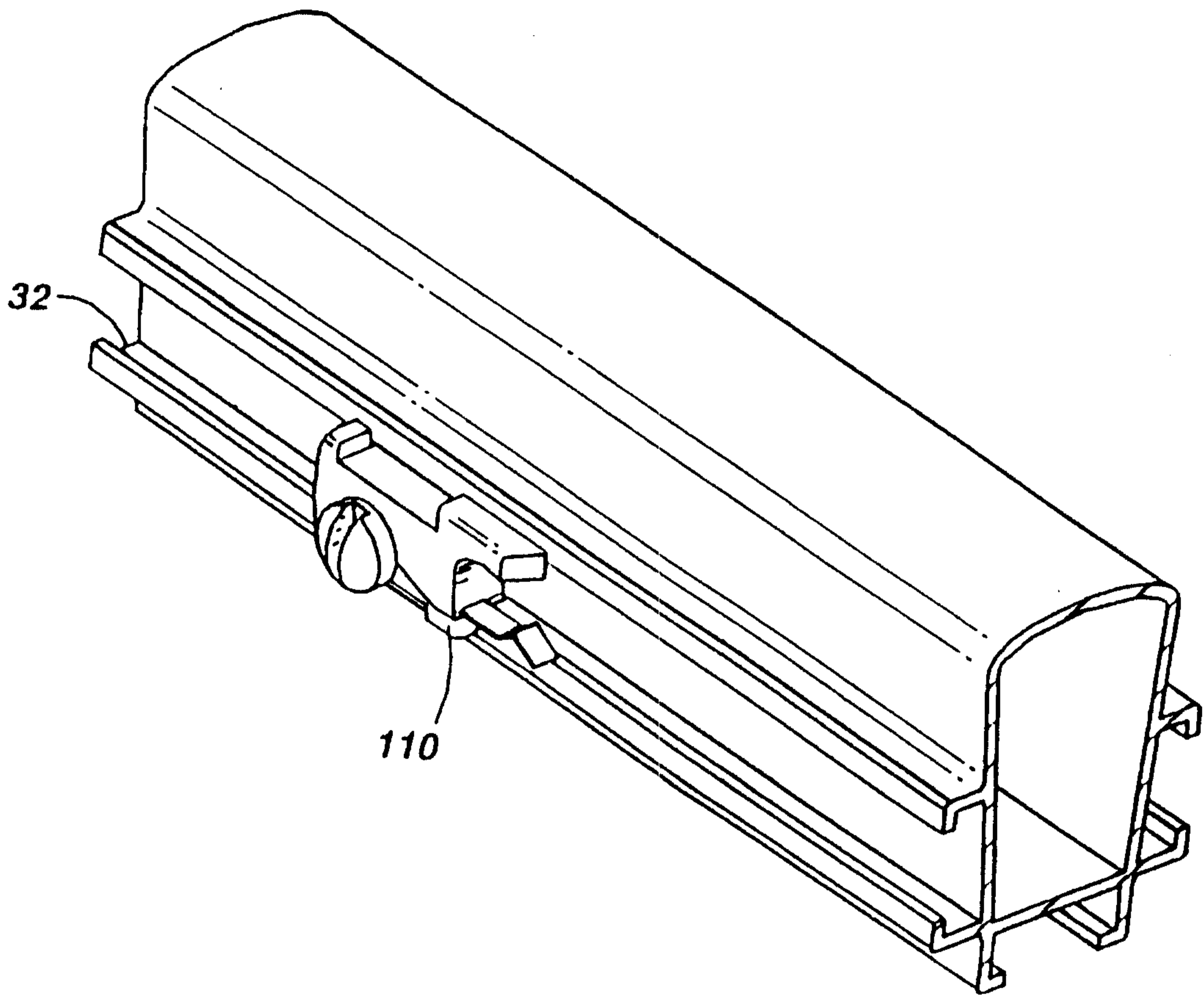

Fig. 10

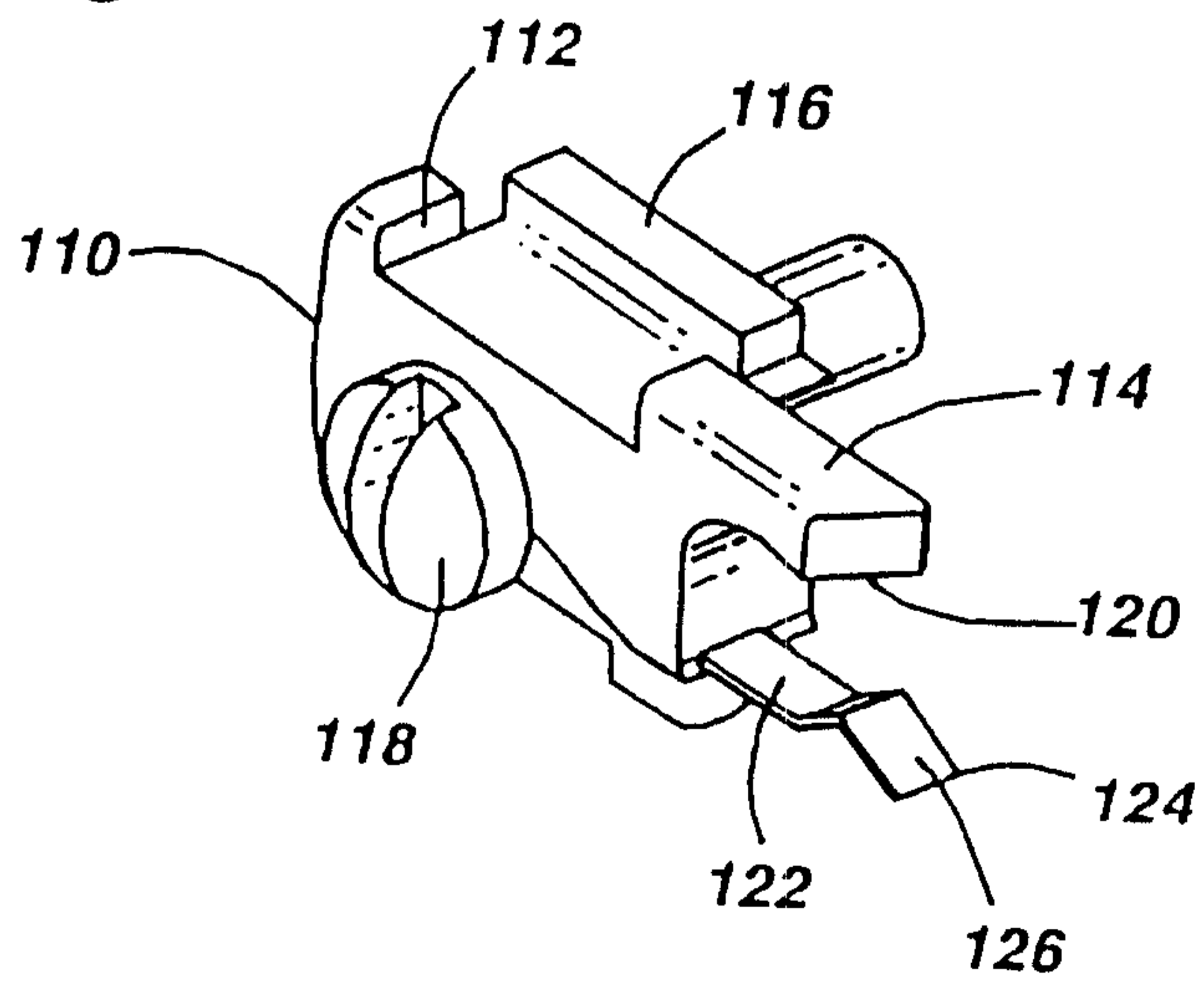

Fig. 11

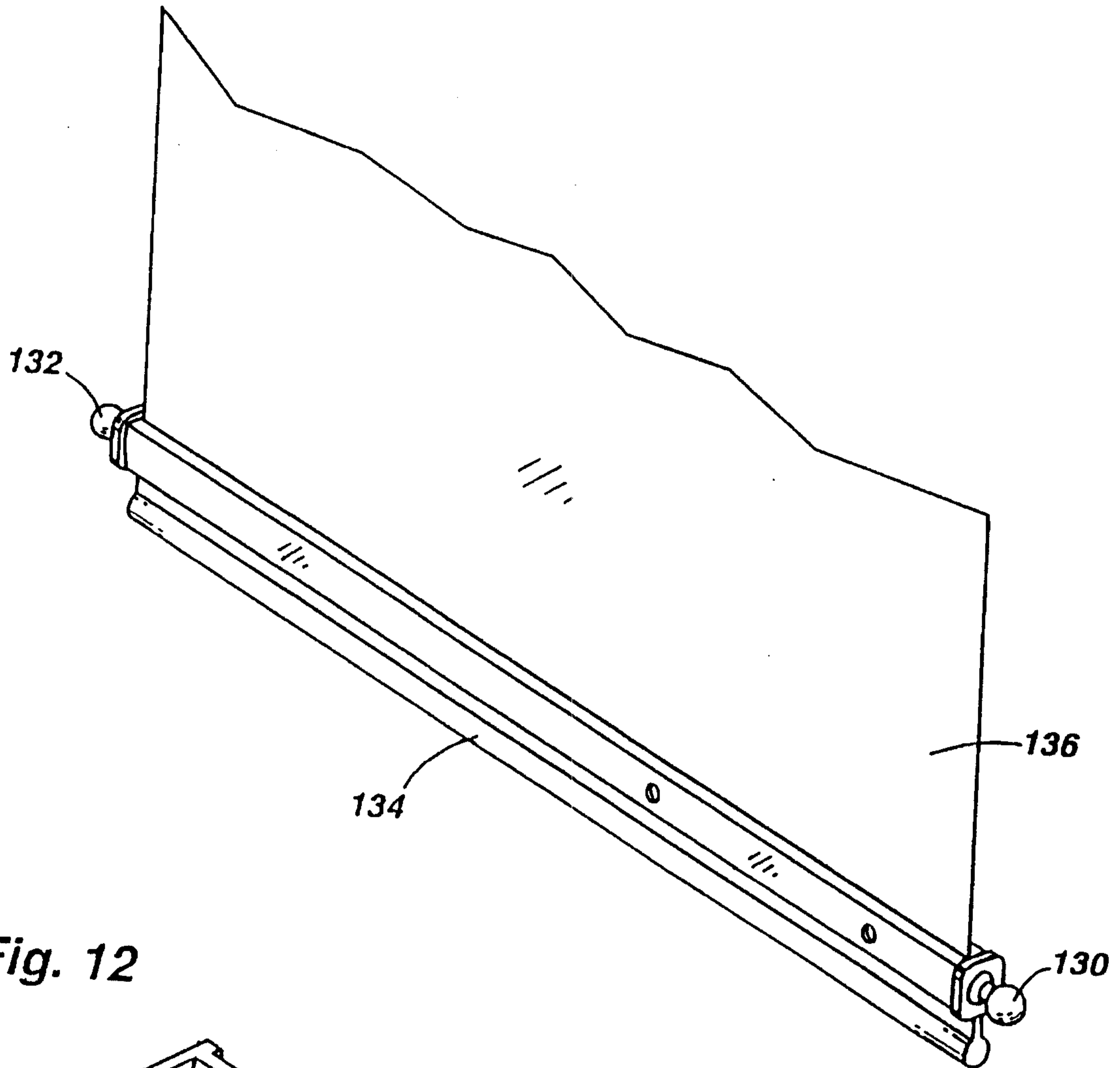

Fig. 12

