



US 20220175890A1

(19) **United States**

(12) **Patent Application Publication**
IMRAN

(10) **Pub. No.: US 2022/0175890 A1**

(43) **Pub. Date: Jun. 9, 2022**

(54) **THERAPEUTIC AGENT PREPARATIONS FOR DELIVERY INTO A LUMEN OF THE INTESTINAL TRACT USING A SWALLOWABLE DRUG DELIVERY DEVICE**

Publication Classification

(51) **Int. Cl.**
A61K 38/27 (2006.01)
A61M 25/10 (2006.01)
A61K 9/00 (2006.01)
A61K 9/48 (2006.01)

(52) **U.S. Cl.**
 CPC *A61K 38/27* (2013.01); *A61M 25/10* (2013.01); *A61L 27/54* (2013.01); *A61K 9/4808* (2013.01); *A61K 9/0053* (2013.01)

(71) Applicant: **Rani Therapeutics, LLC**, San Jose, CA (US)

(72) Inventor: **Mir IMRAN**, Los Altos Hills, CA (US)

(73) Assignee: **Rani Therapeutics, LLC**, San Jose, CA (US)

(21) Appl. No.: **17/552,325**

(22) Filed: **Dec. 15, 2021**

(57) **ABSTRACT**

Related U.S. Application Data

(63) Continuation of application No. 16/405,909, filed on May 7, 2019, now Pat. No. 11,229,684, which is a continuation of application No. 15/824,976, filed on Nov. 28, 2017, now Pat. No. 10,335,463, which is a continuation of application No. 13/538,793, filed on Jun. 29, 2012, now Pat. No. 9,861,683, which is a continuation-in-part of application No. 12/978,164, filed on Dec. 23, 2010, now Pat. No. 8,759,284, which is a continuation-in-part of application No. 12/978,233, filed on Dec. 23, 2010, now Pat. No. 8,721,620, which is a continuation-in-part of application No. 12/978,301, filed on Dec. 23, 2010, now Pat. No. 8,562,589.

(60) Provisional application No. 61/571,641, filed on Jun. 29, 2011, provisional application No. 61/571,632, filed on Jun. 29, 2011.

Embodiments of the invention provide swallowable devices, preparations and methods for delivering drugs and other therapeutic agents within the GI tract. Many embodiments provide a swallowable device for delivering the agents. Particular embodiments provide a swallowable device such as a capsule for delivering drugs into the intestinal wall or other GI lumen. Embodiments also provide various drug preparations that are configured to be contained within the capsule, advanced from the capsule into the intestinal wall and degrade to release the drug into the bloodstream to produce a therapeutic effect. The preparation can be operably coupled to delivery means having a first configuration where the preparation is contained in the capsule and a second configuration where the preparation is advanced out of the capsule into the intestinal wall. Embodiments of the invention are particularly useful for the delivery of drugs which are poorly absorbed, tolerated and/or degraded within the GI tract.

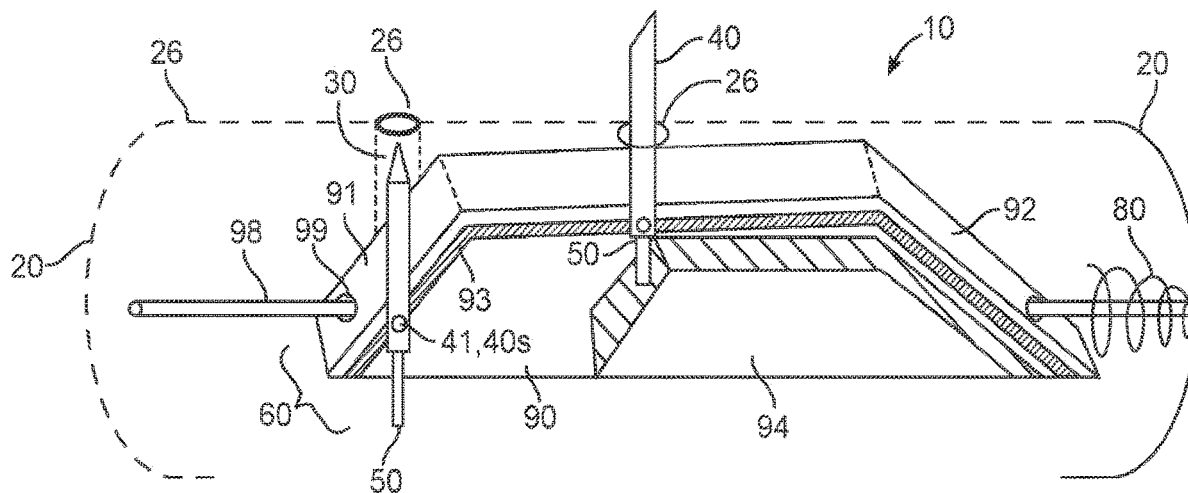

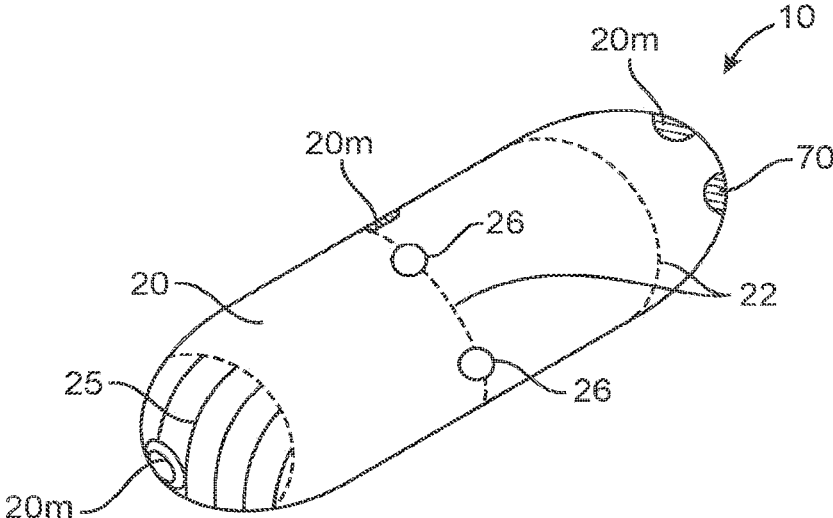

FIG. 1a

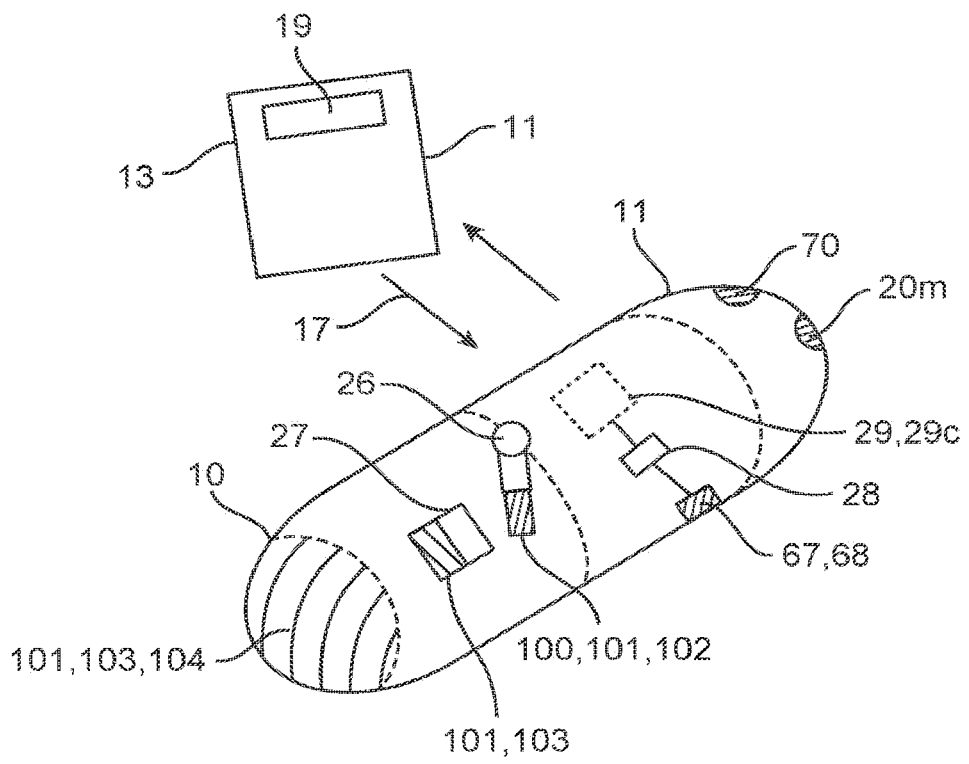

FIG. 1b

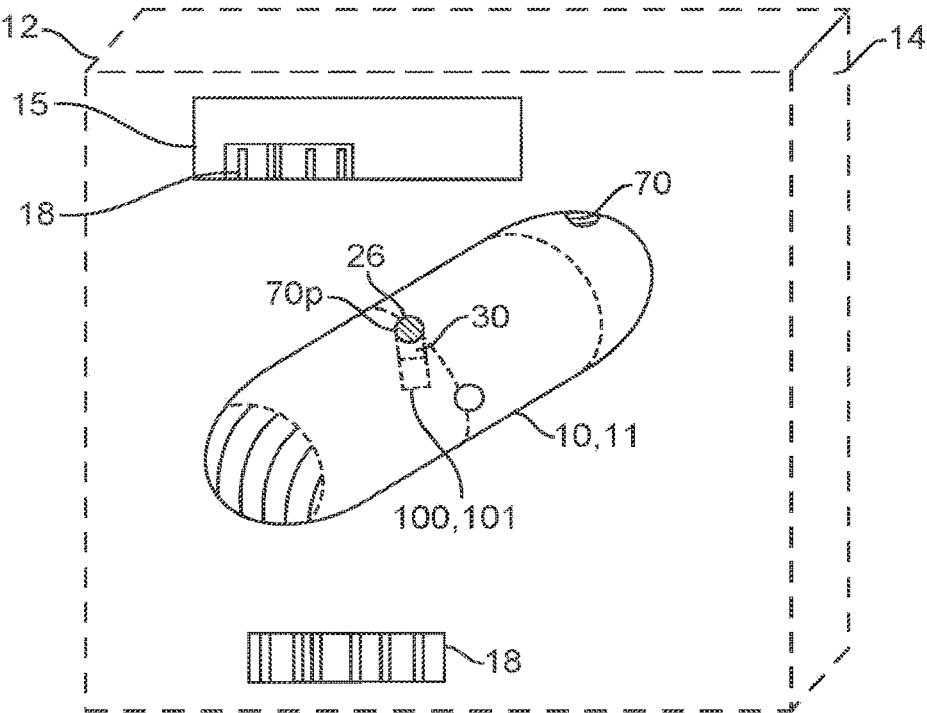

FIG. 1c

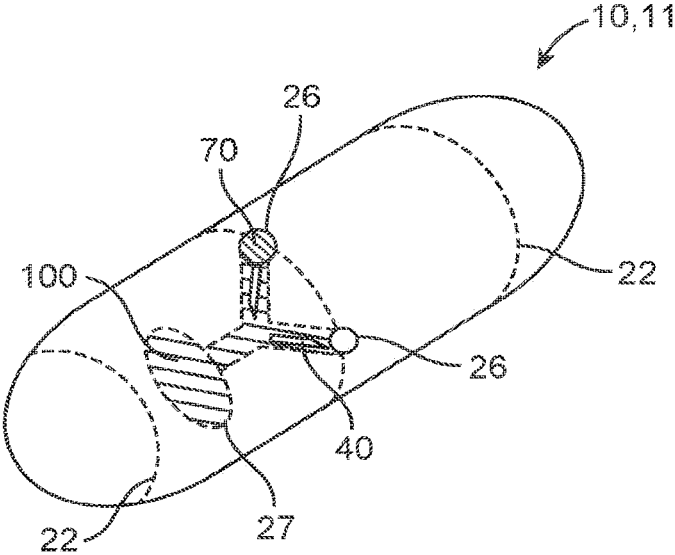

FIG. 1d

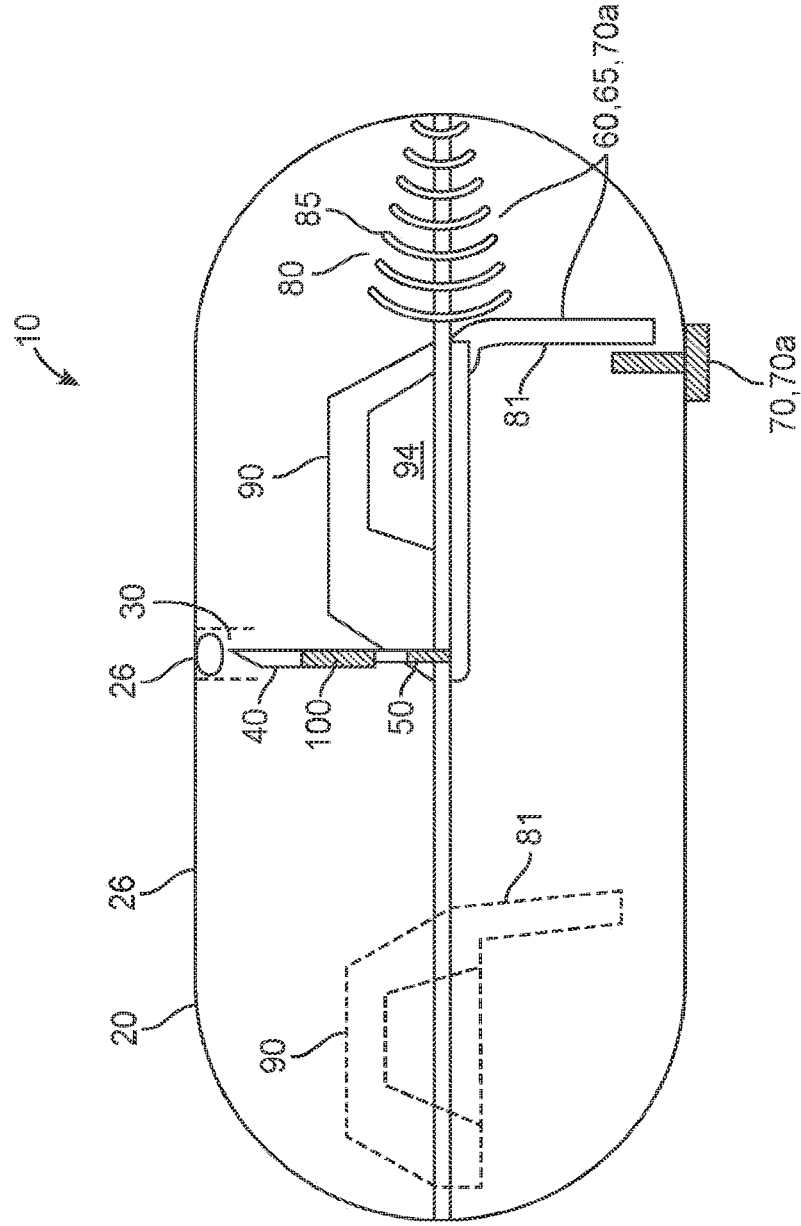

FIG. 2

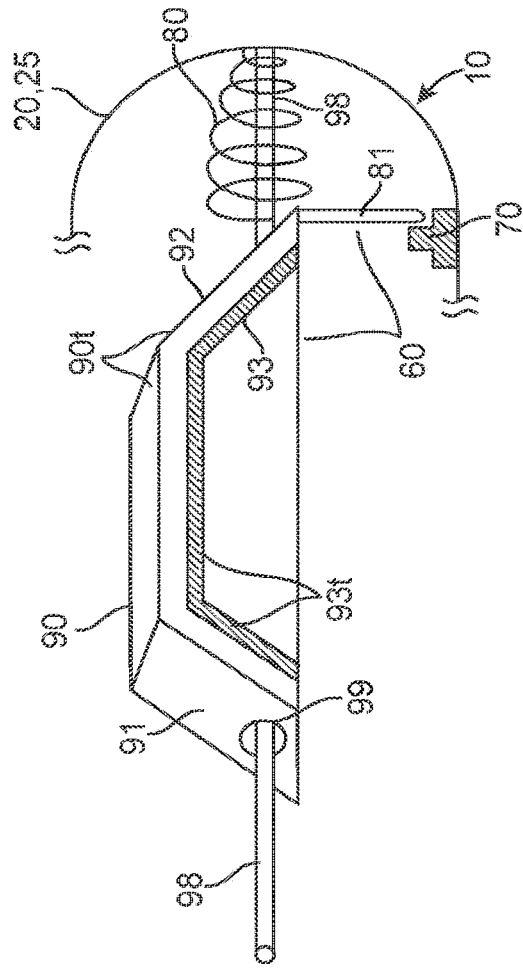

FIG. 3

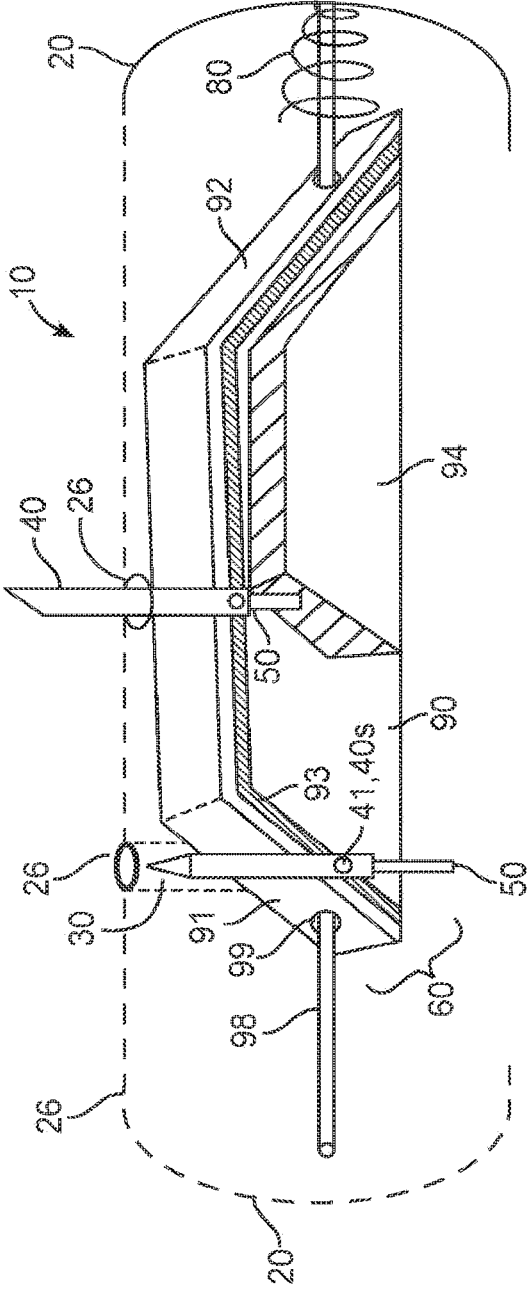

FIG. 4

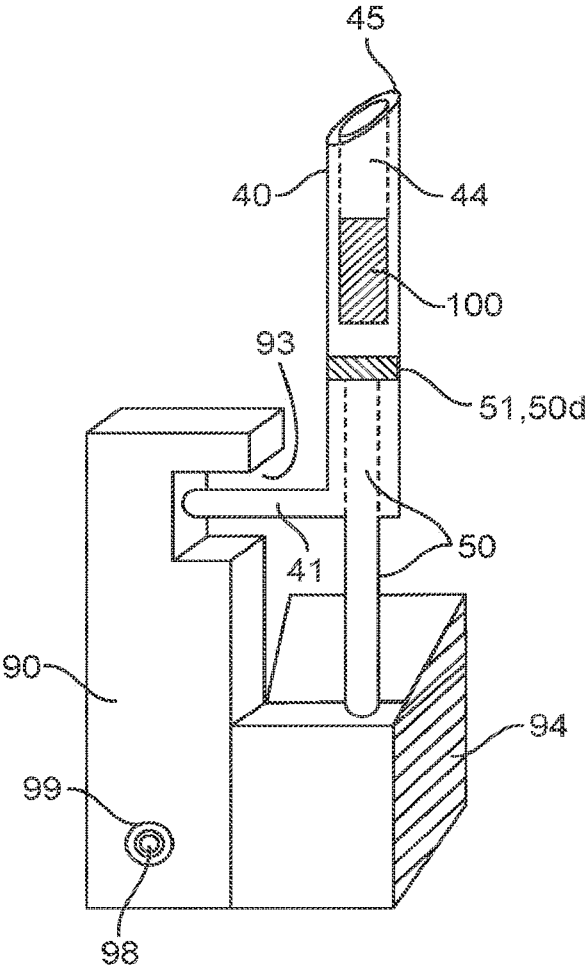

FIG. 5

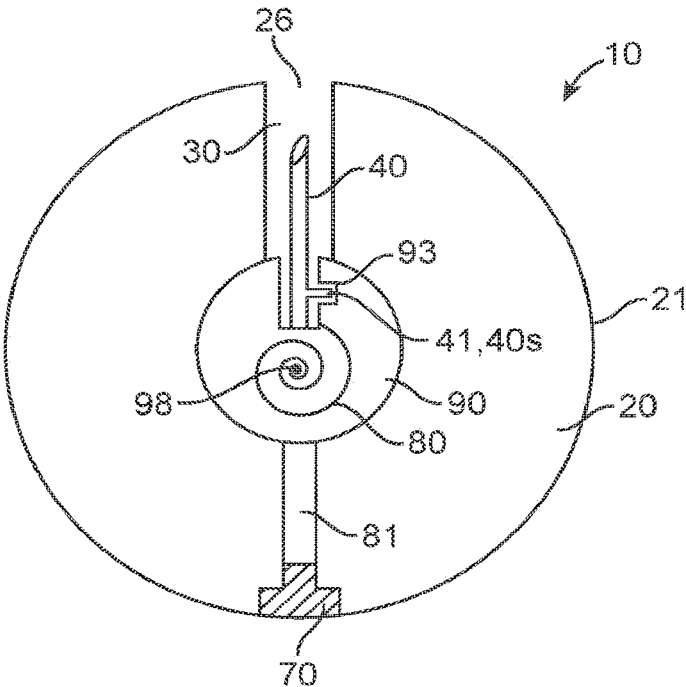

FIG. 6

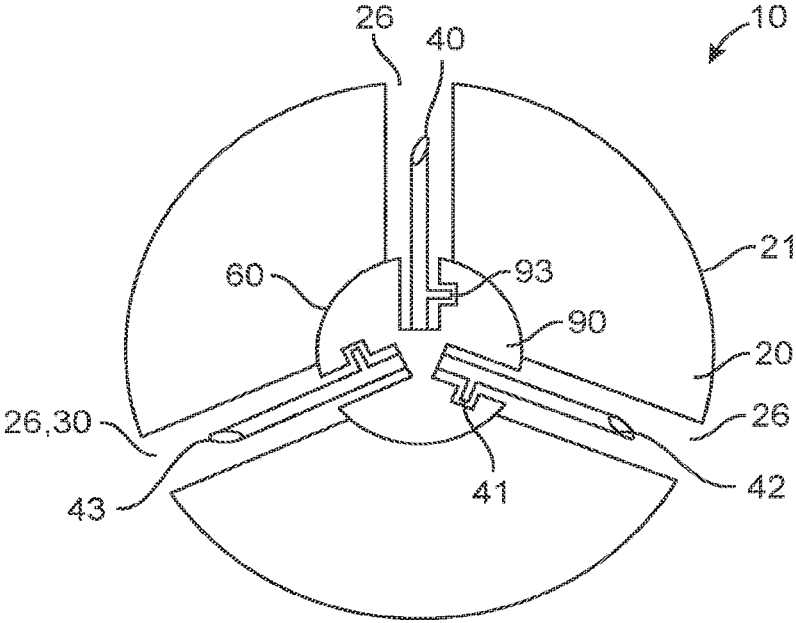

FIG. 7a

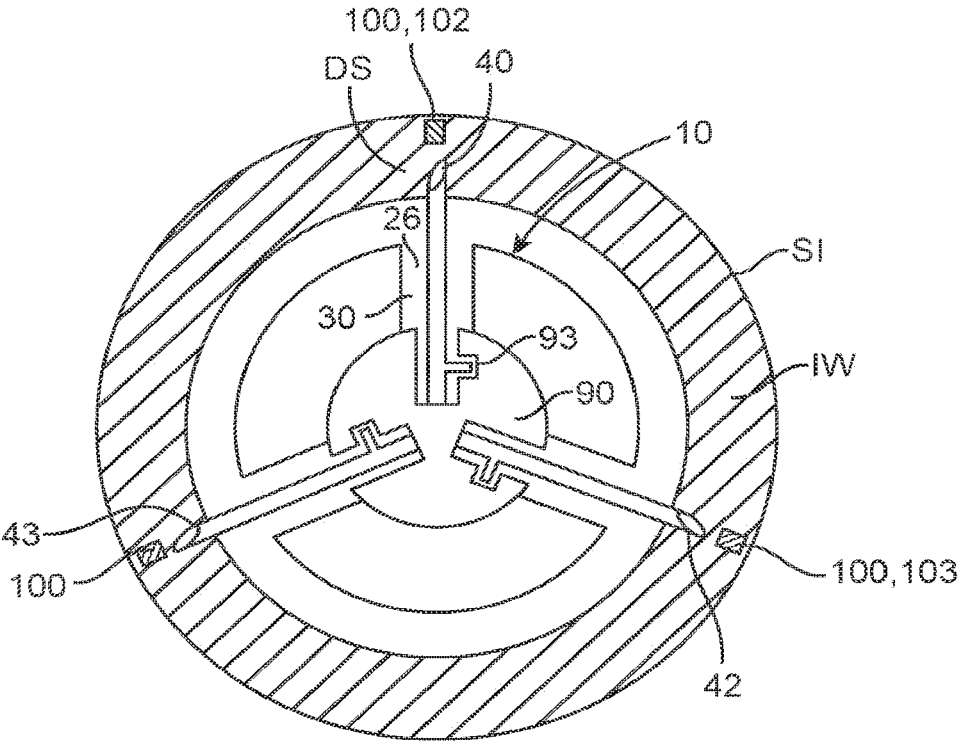

FIG. 7b

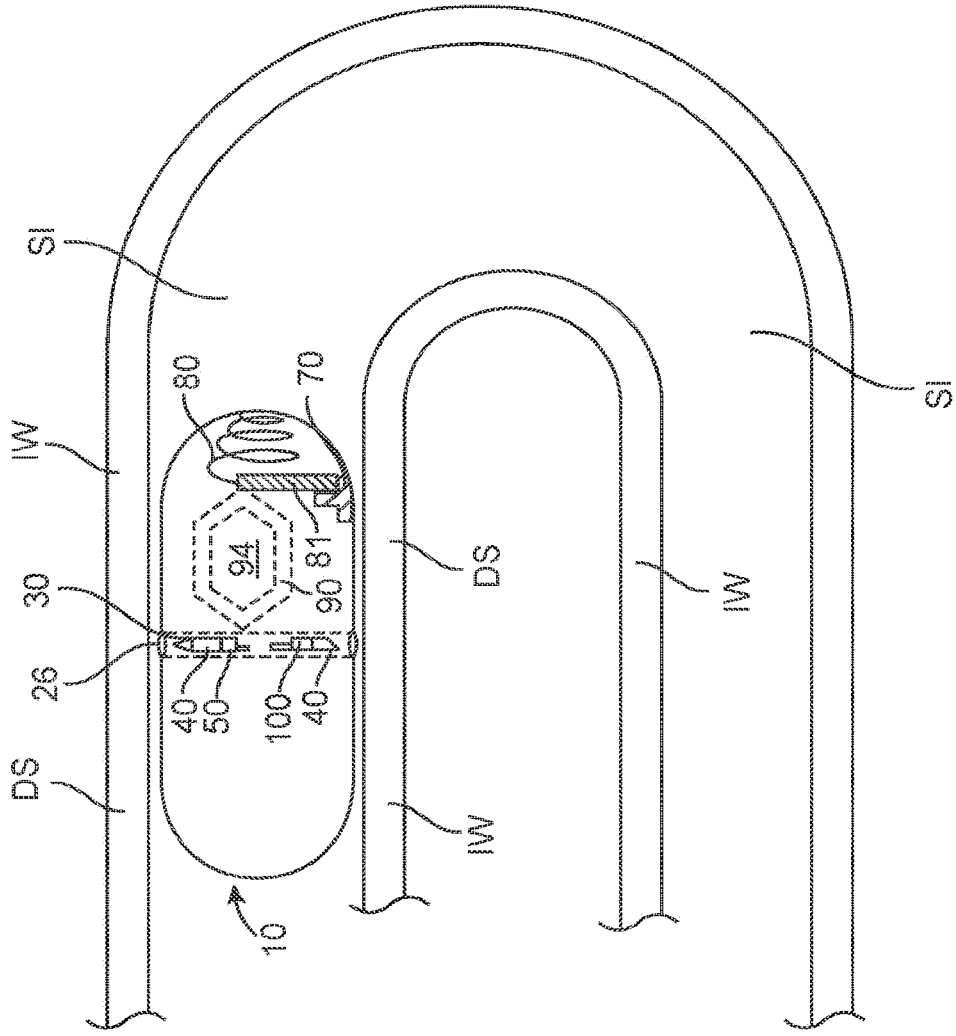

FIG. 8a

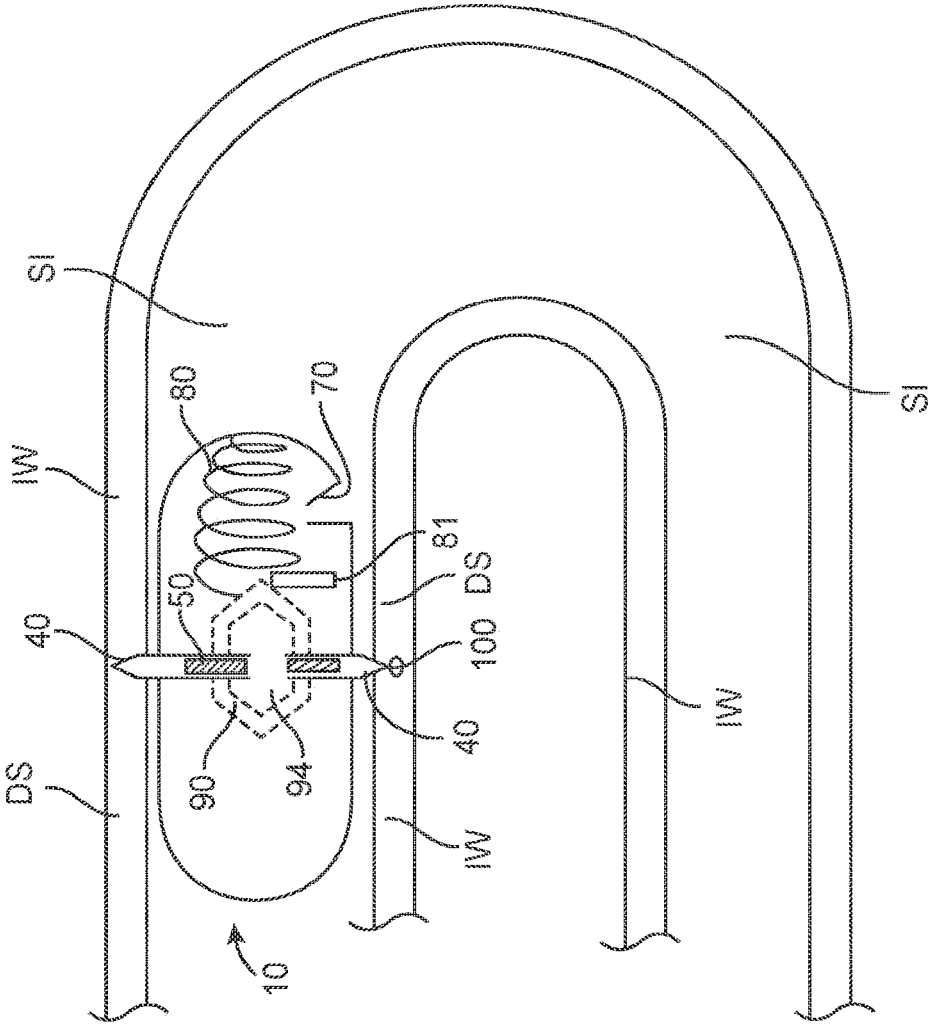

FIG. 8b

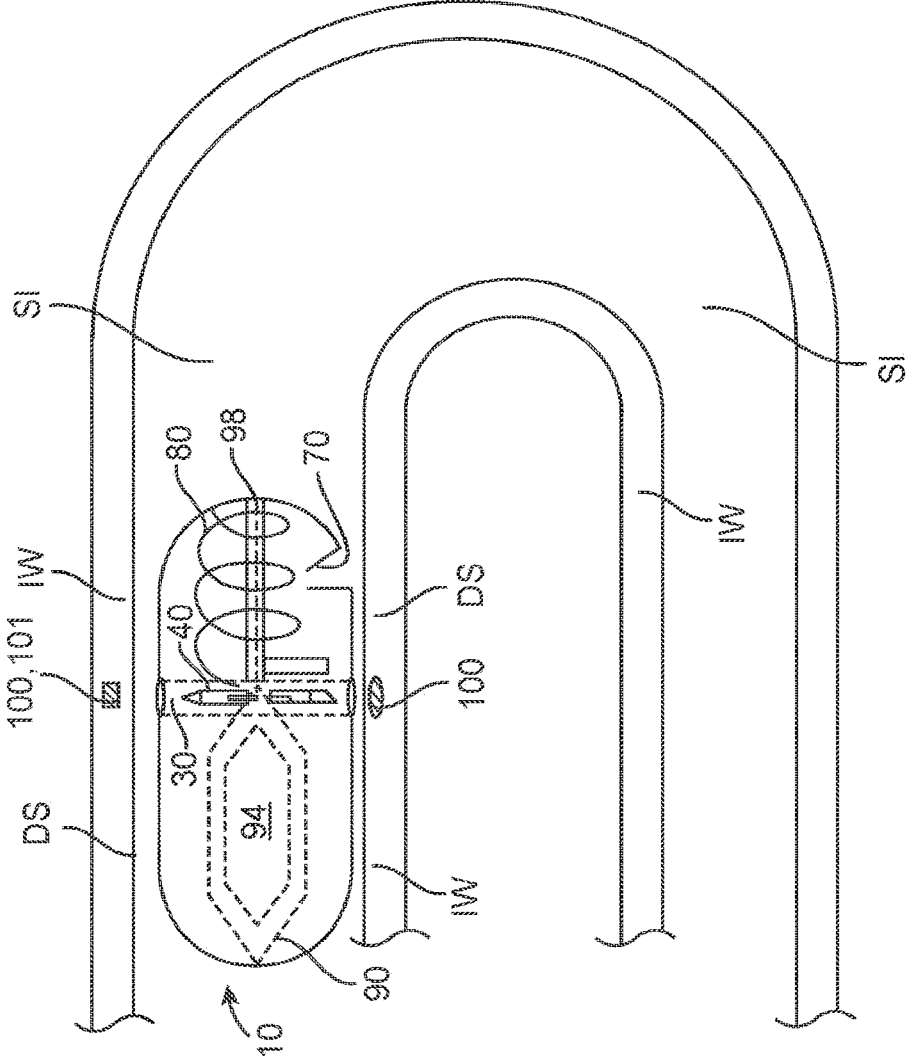

FIG. 8c

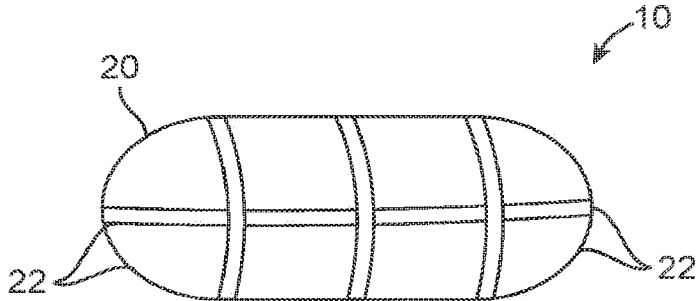

FIG. 9a

↓ Deglutition

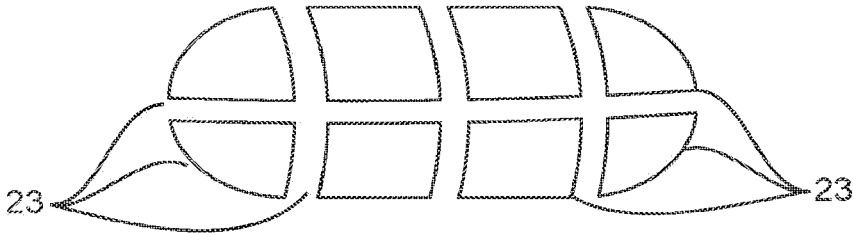

FIG. 9b

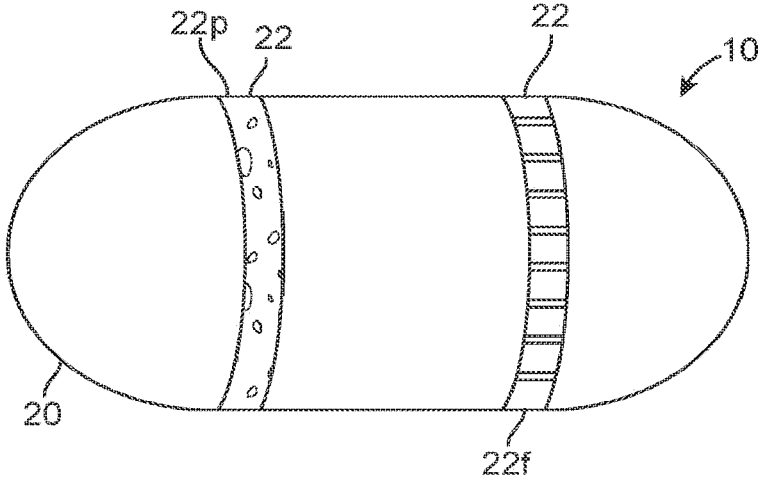

FIG. 10

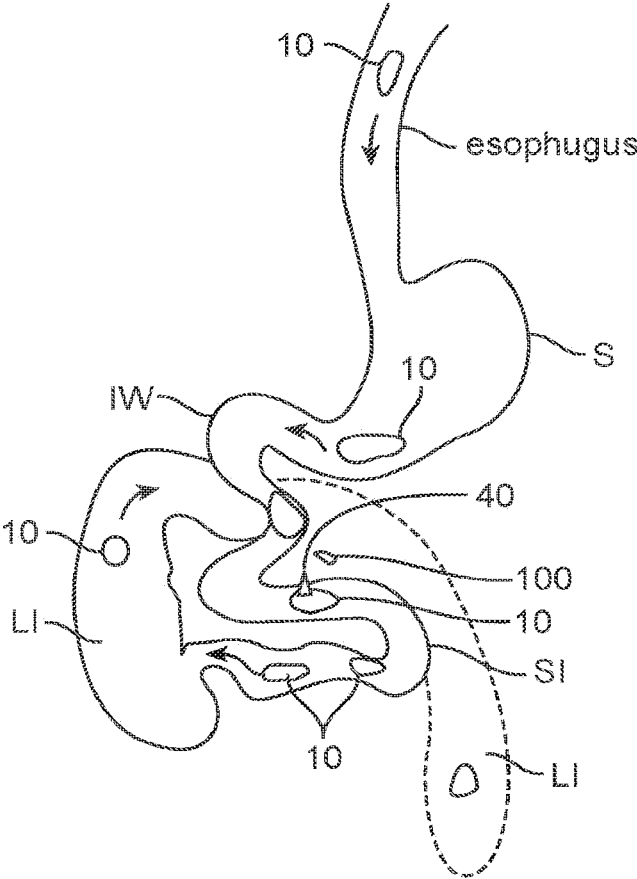

FIG. 11

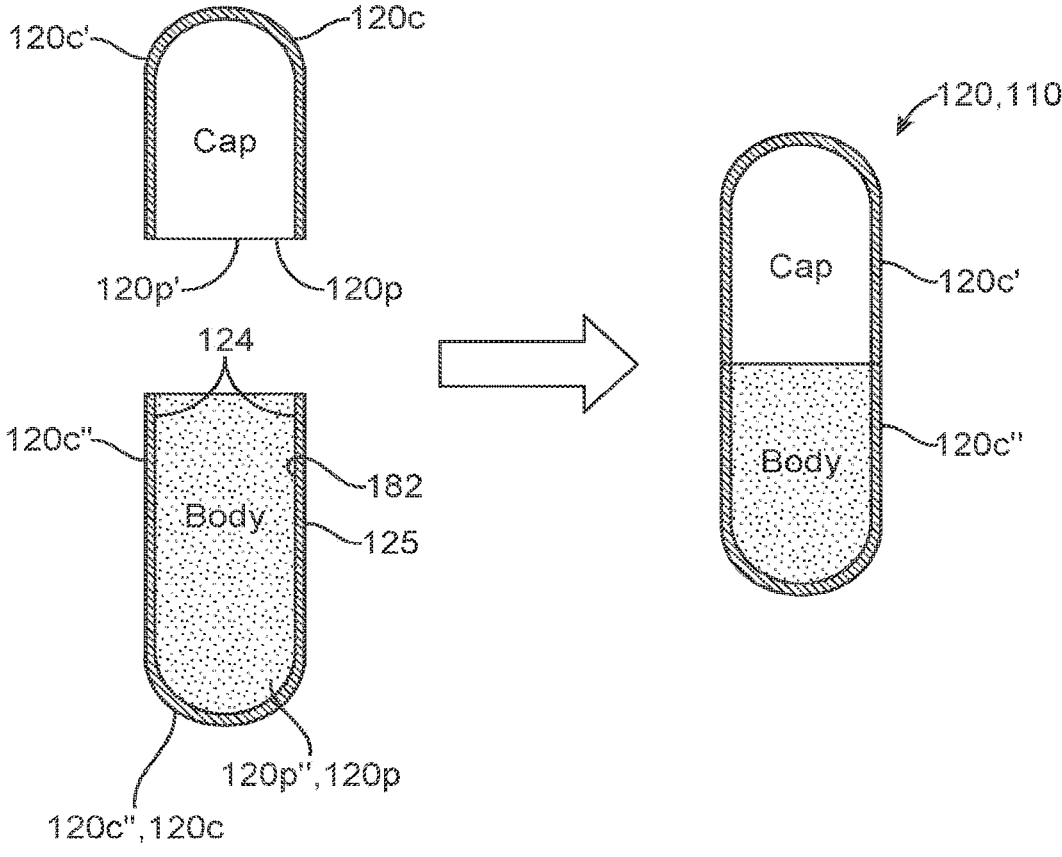

FIG. 12a

FIG. 12b

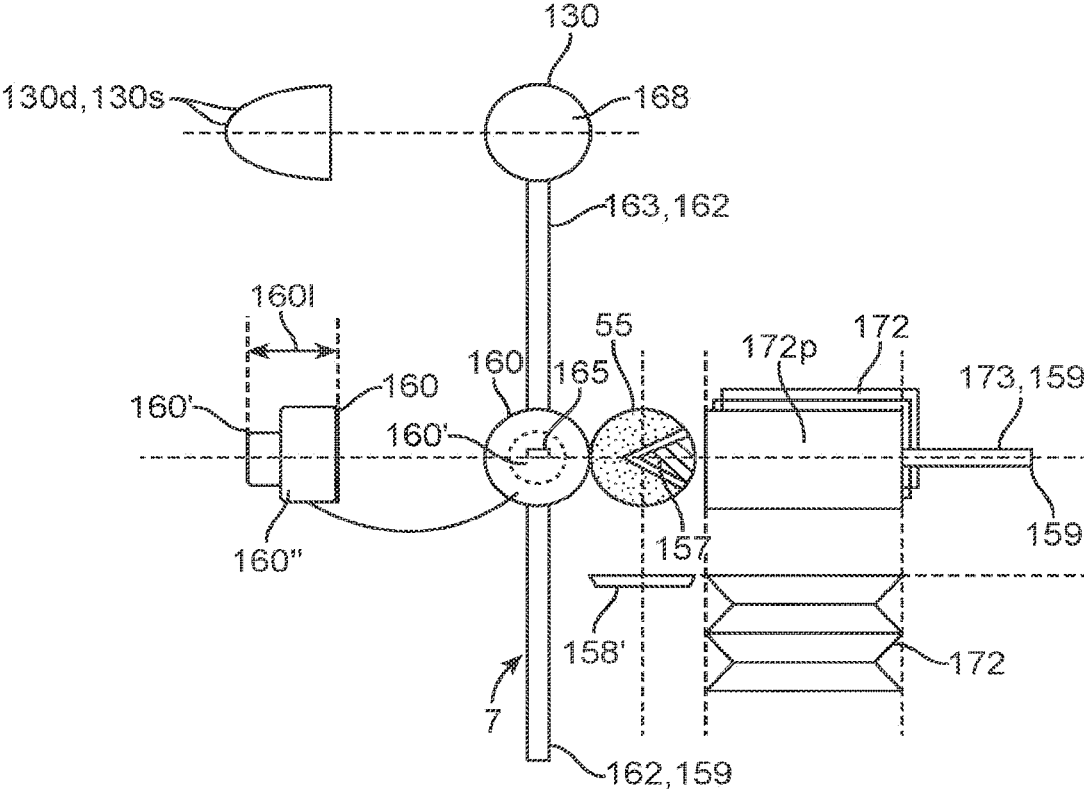

FIG. 13a

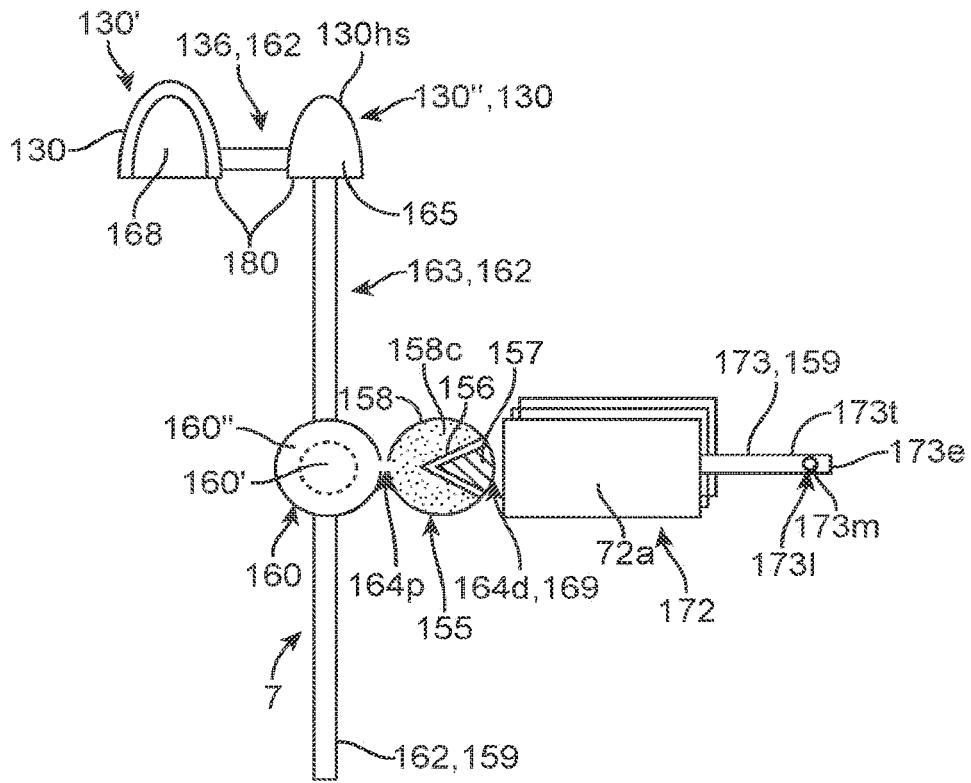

FIG. 13b

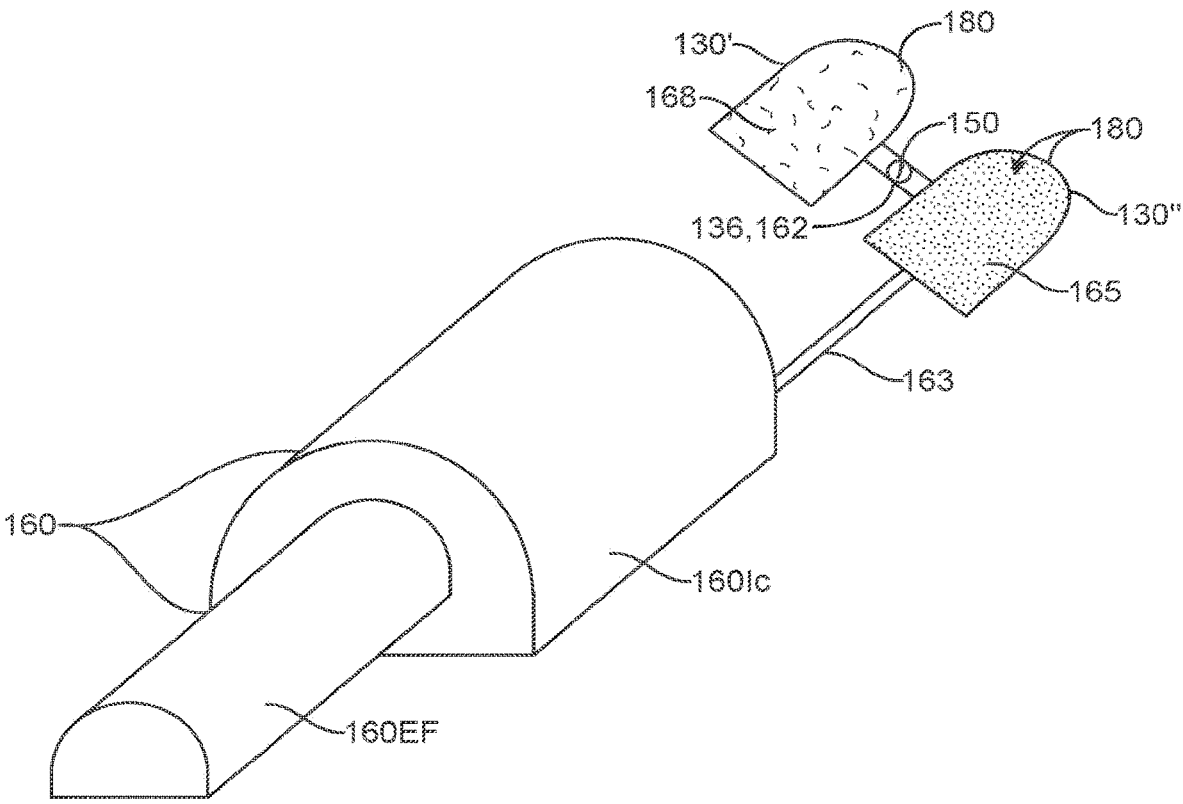

FIG. 13c

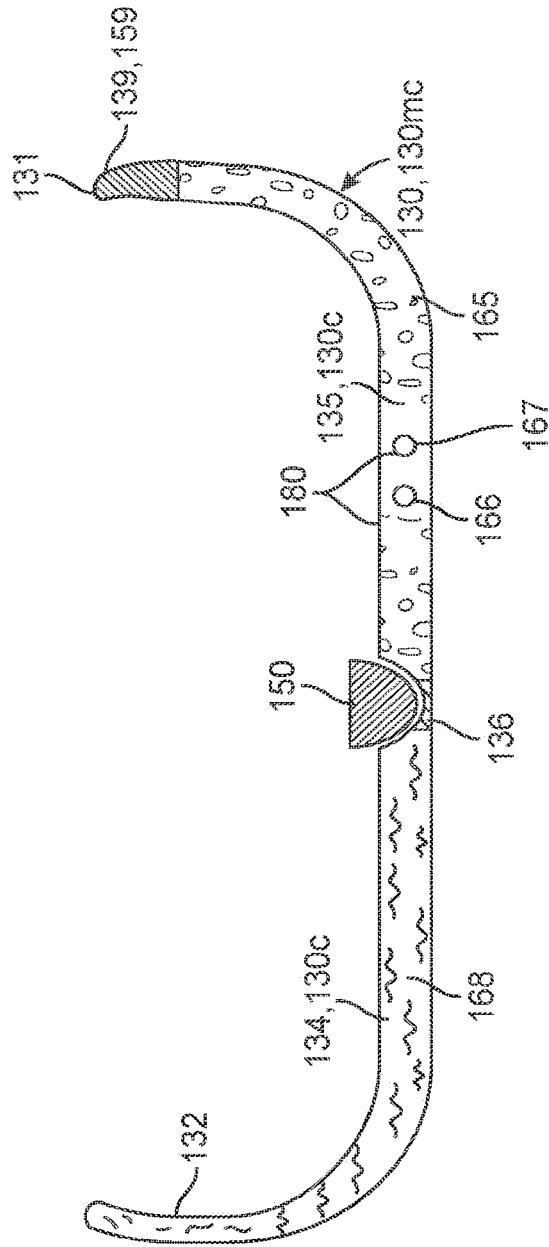

FIG. 14a

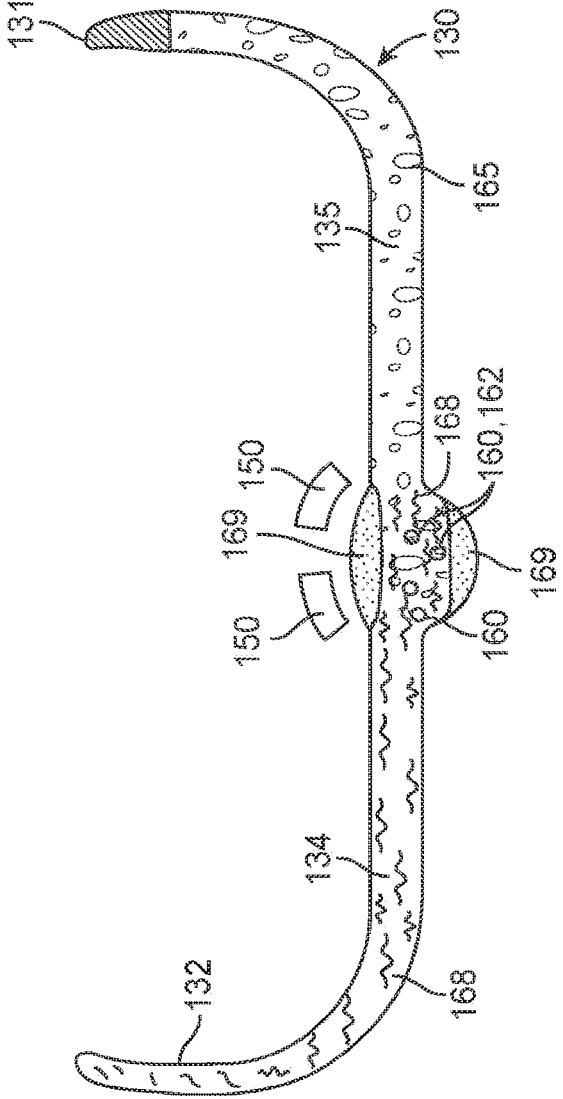

FIG. 14b

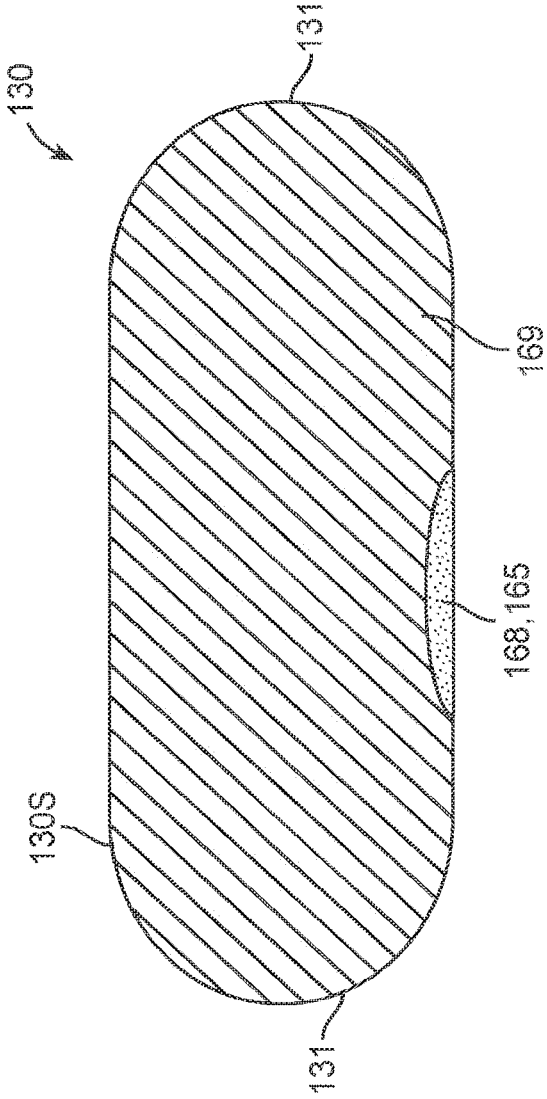

FIG. 14C

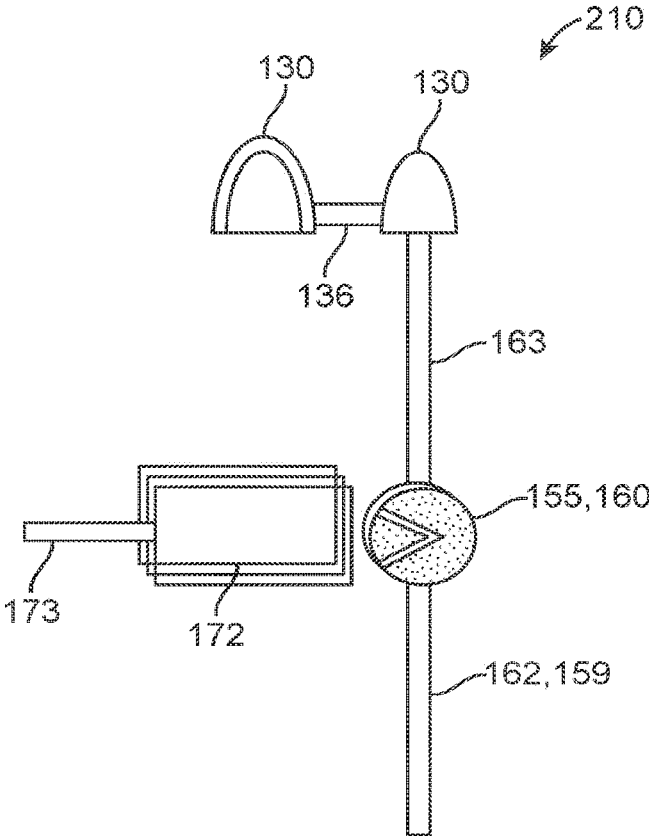

FIG. 15a

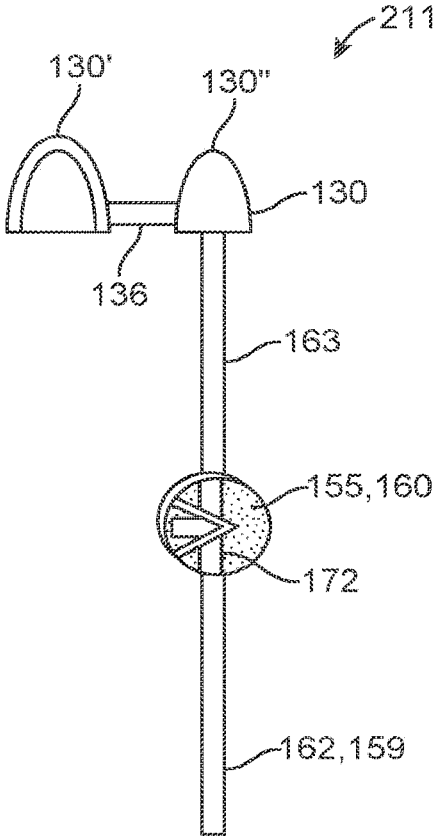

FIG. 15b

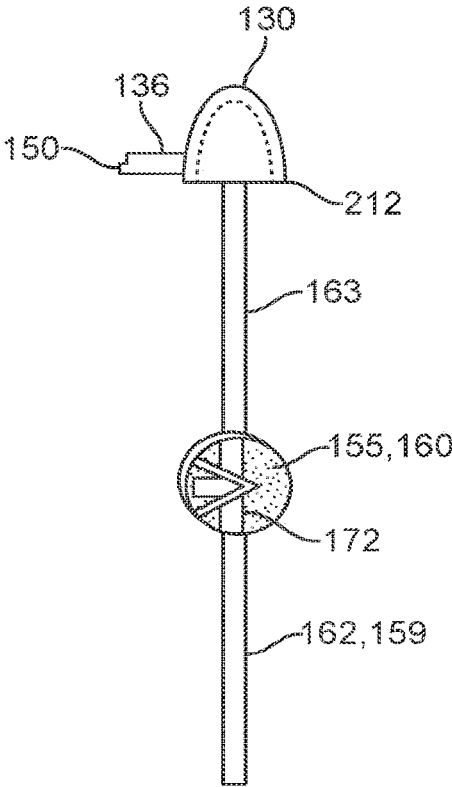

FIG. 15c

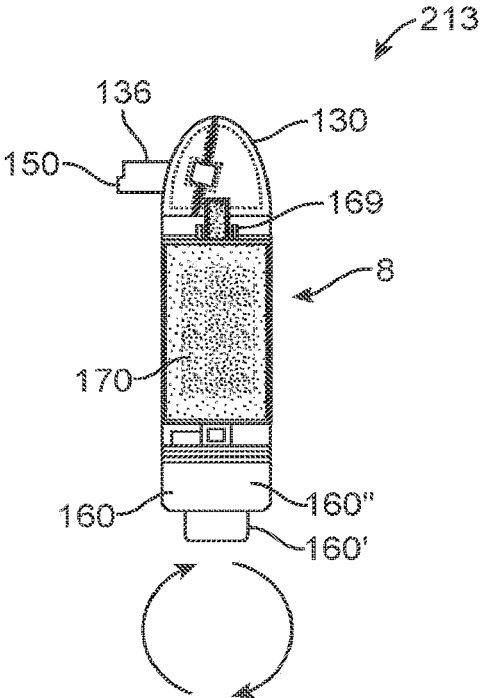

FIG. 15d

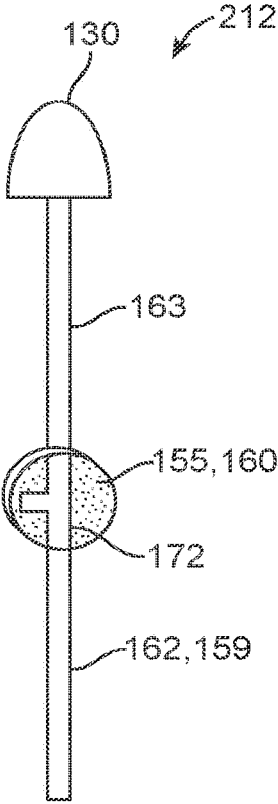

FIG. 15e

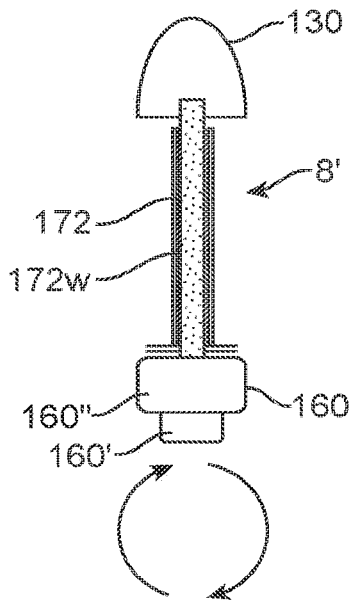

FIG. 15f

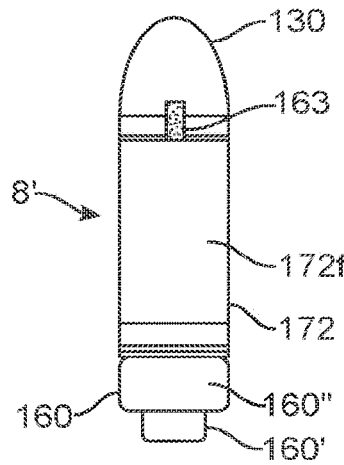

FIG. 15g

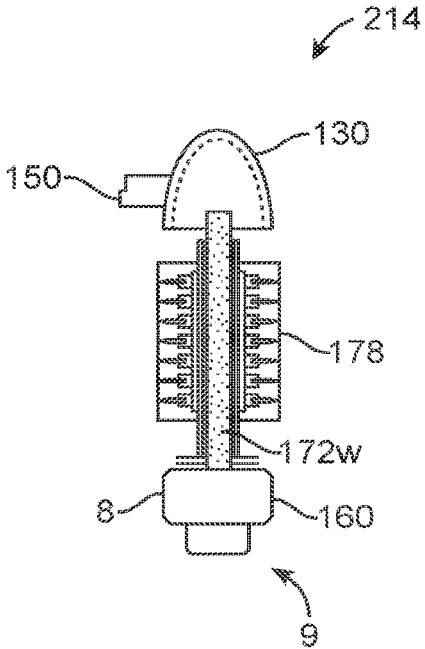

FIG. 16a

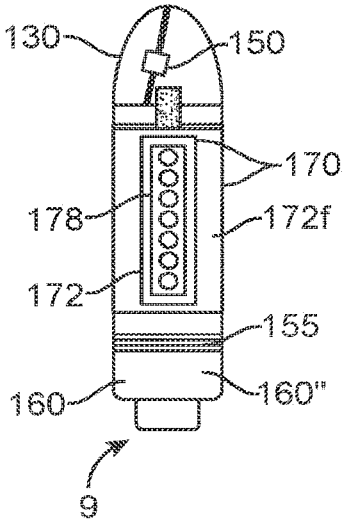

FIG. 16b

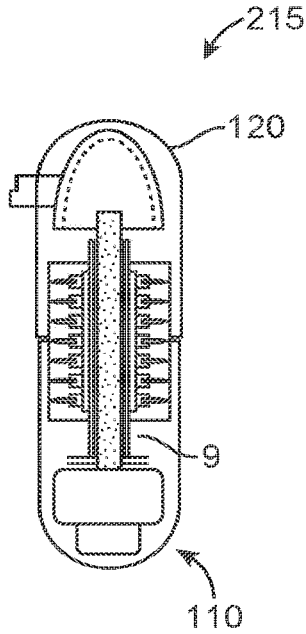

FIG. 17a

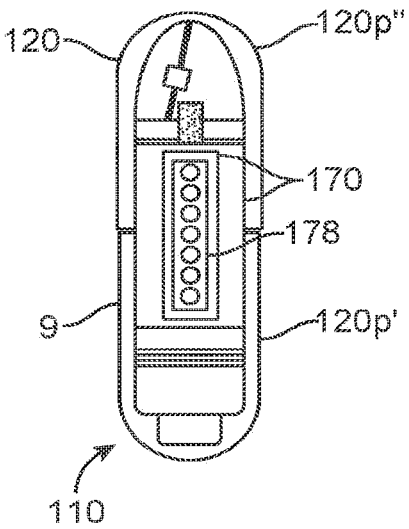

FIG. 17b

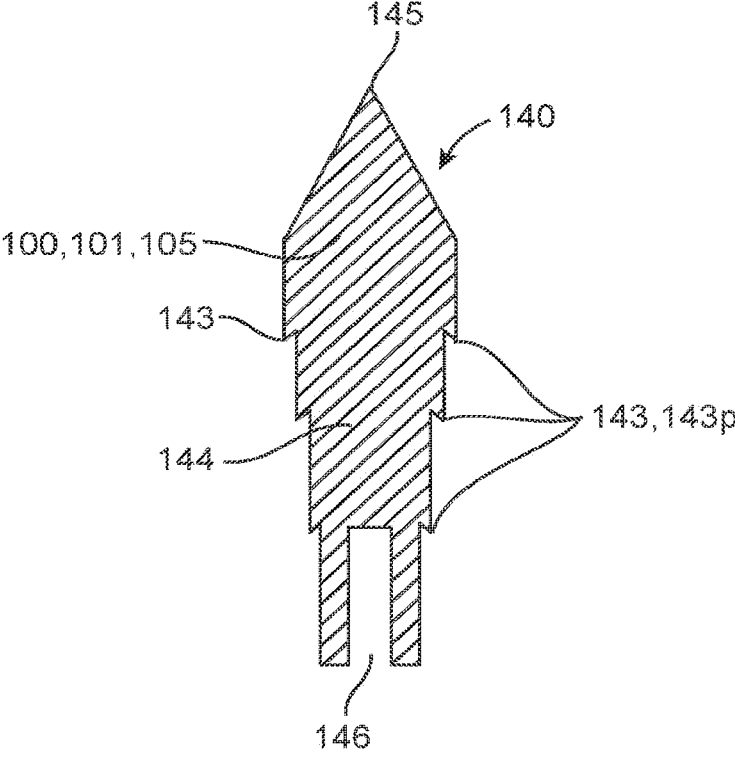

FIG. 18a

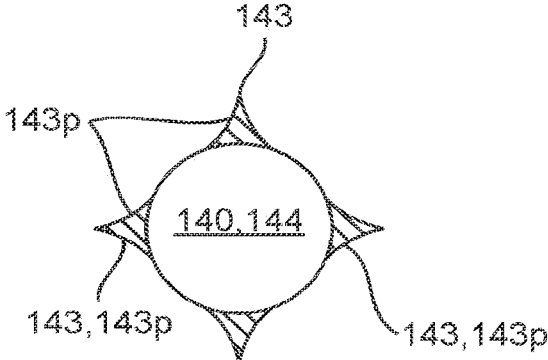

FIG. 18b

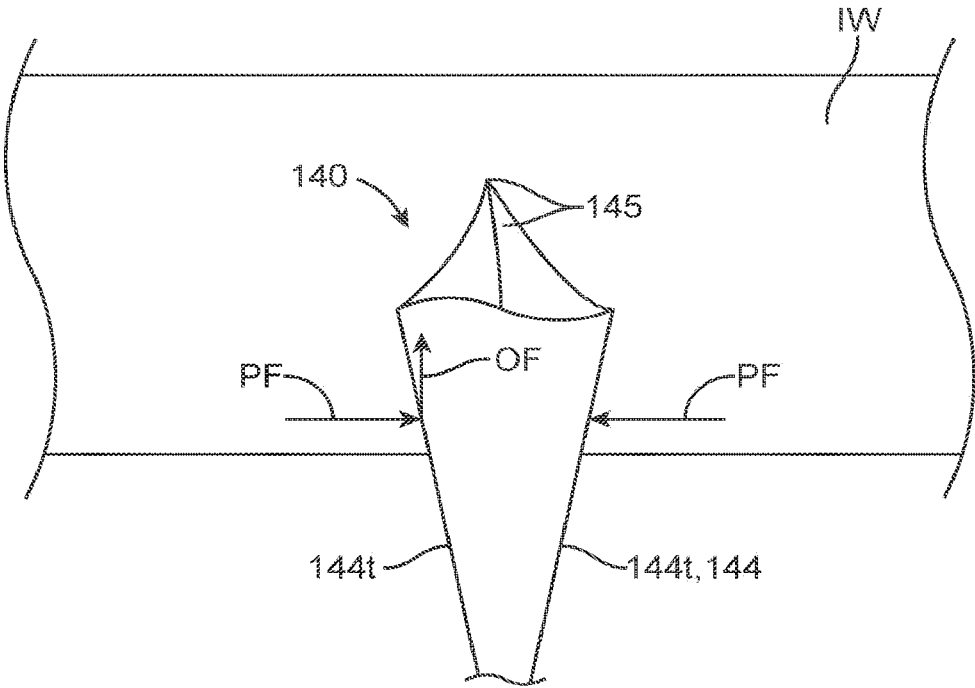

FIG. 18c

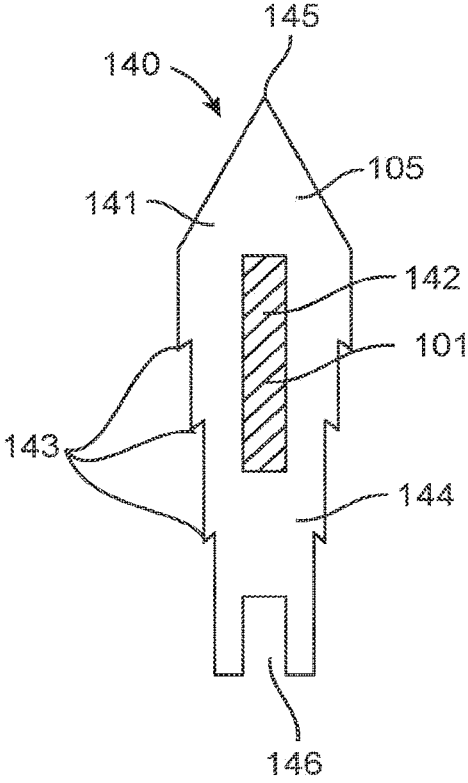

FIG. 18d

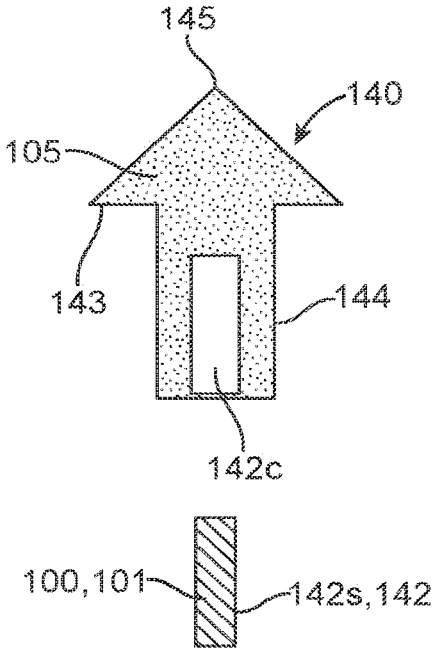

FIG. 18e

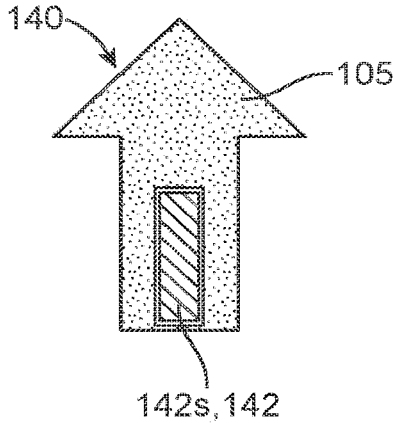

FIG. 18f

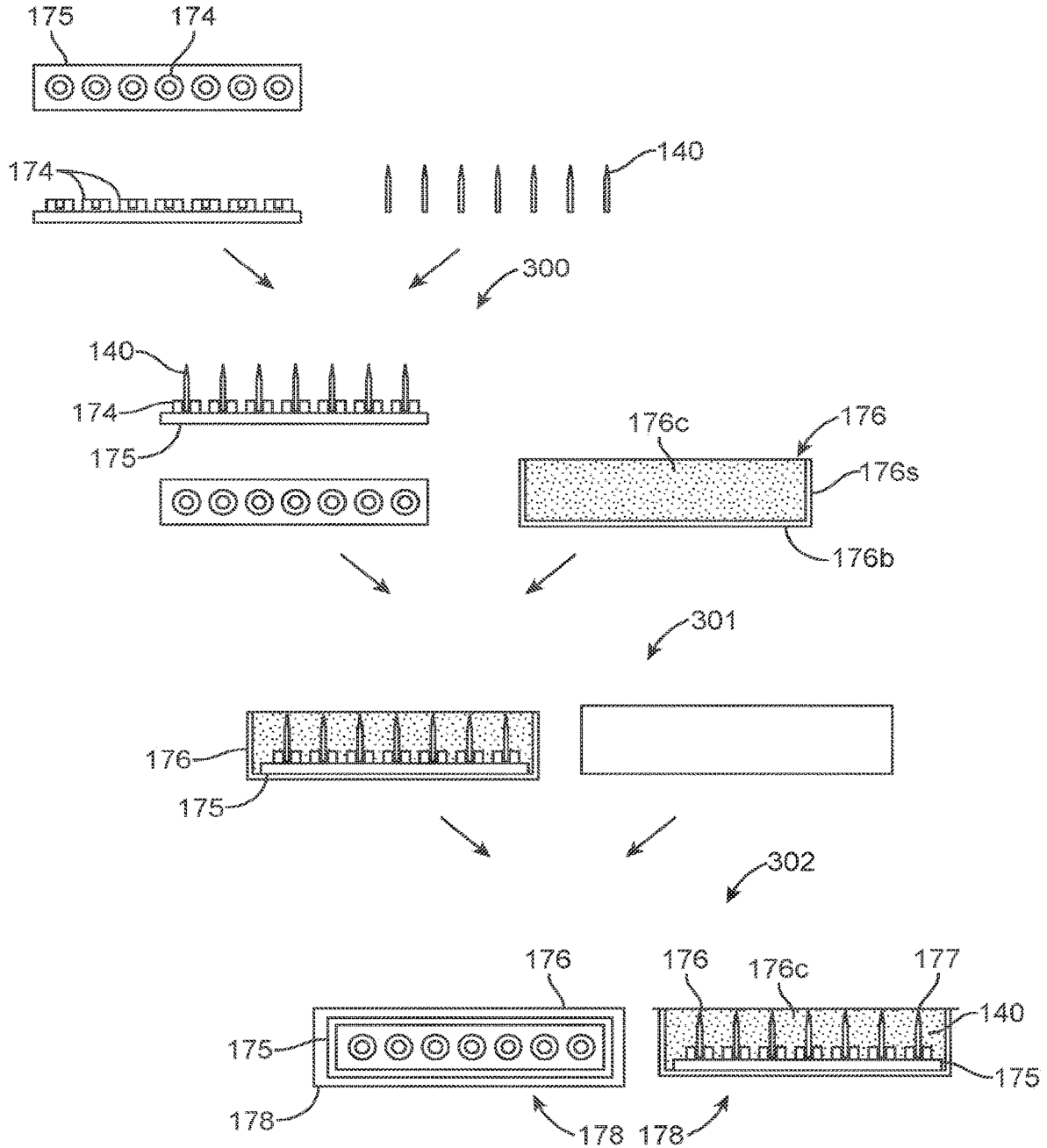

FIG. 19

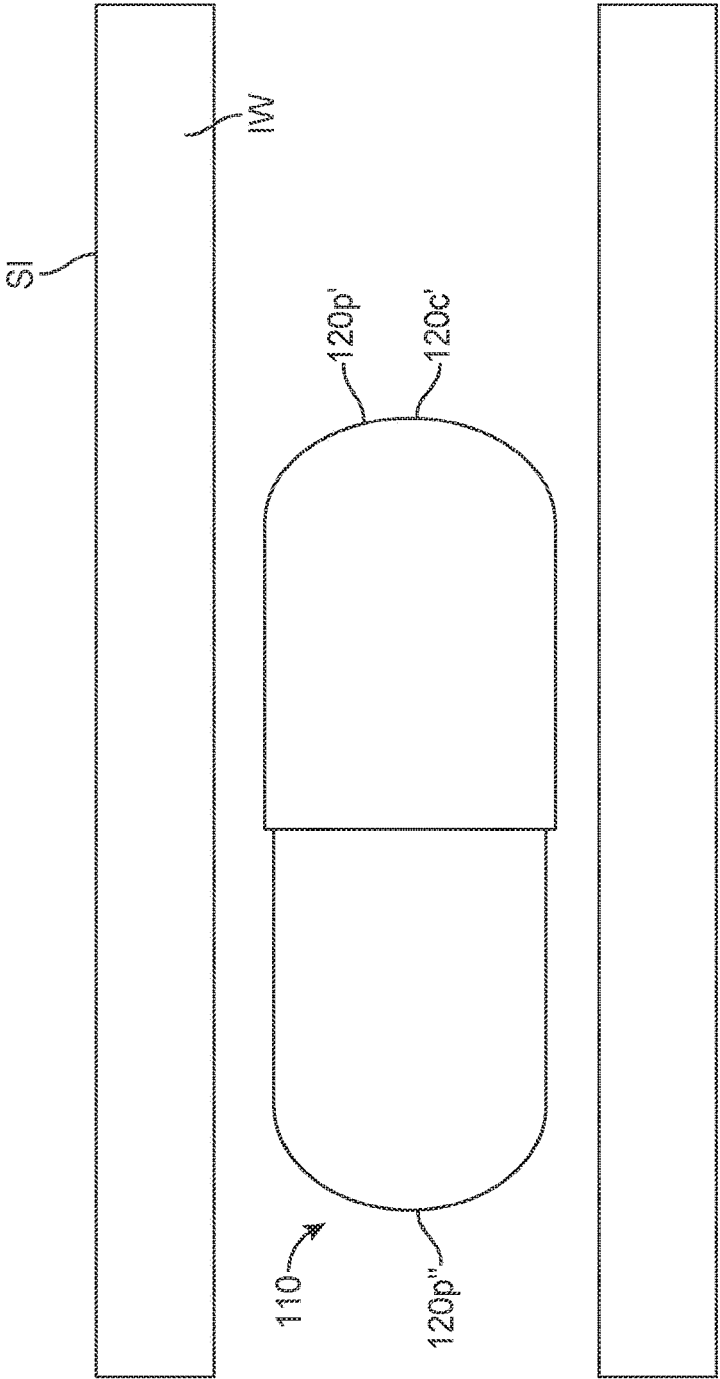

FIG. 20a

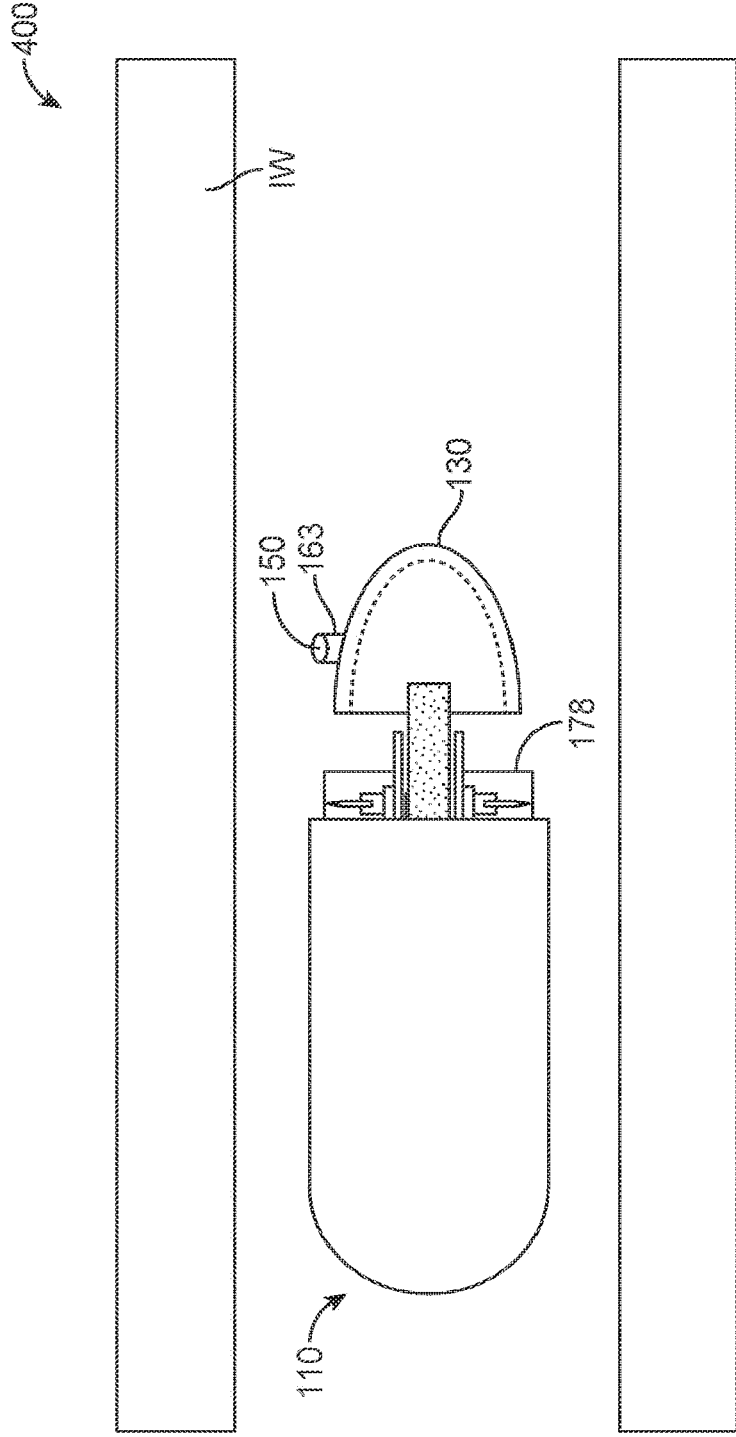

FIG. 20b

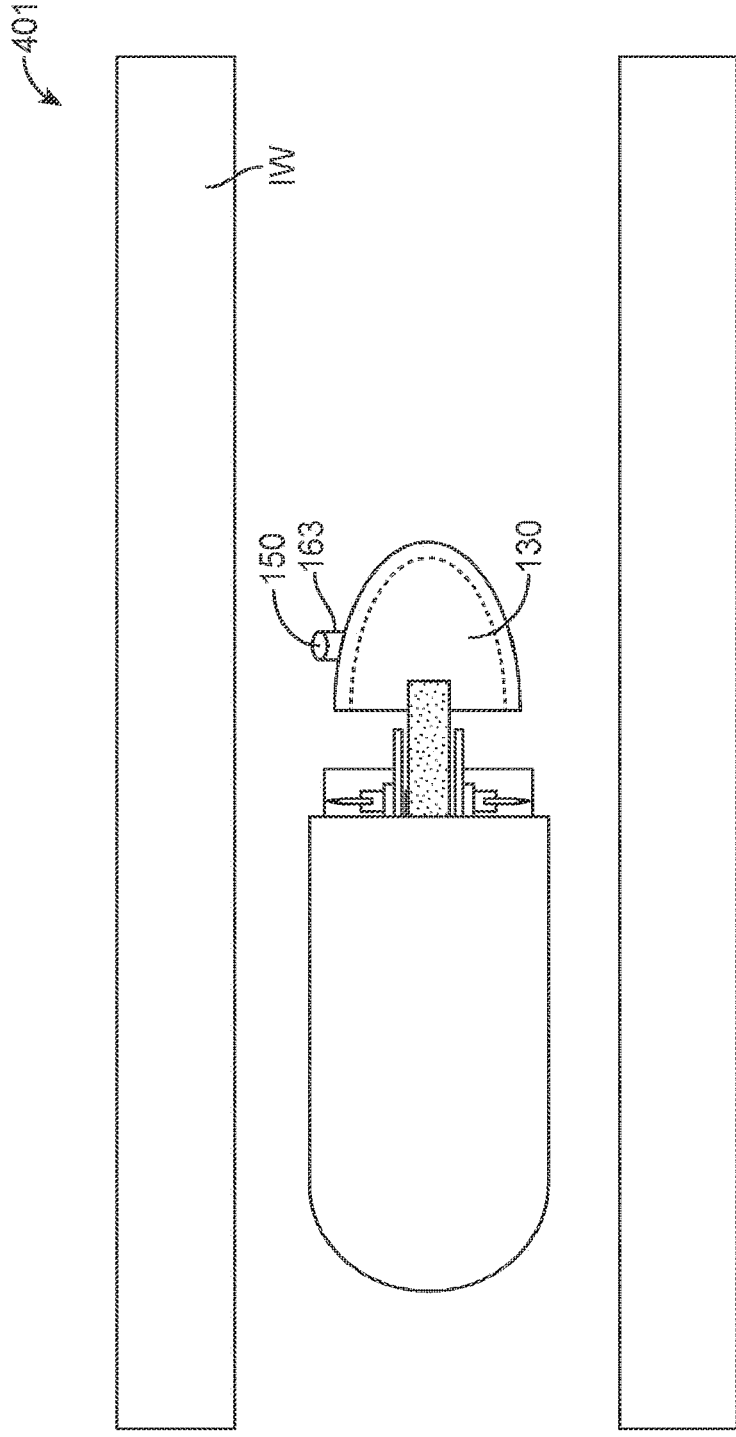

FIG. 20c

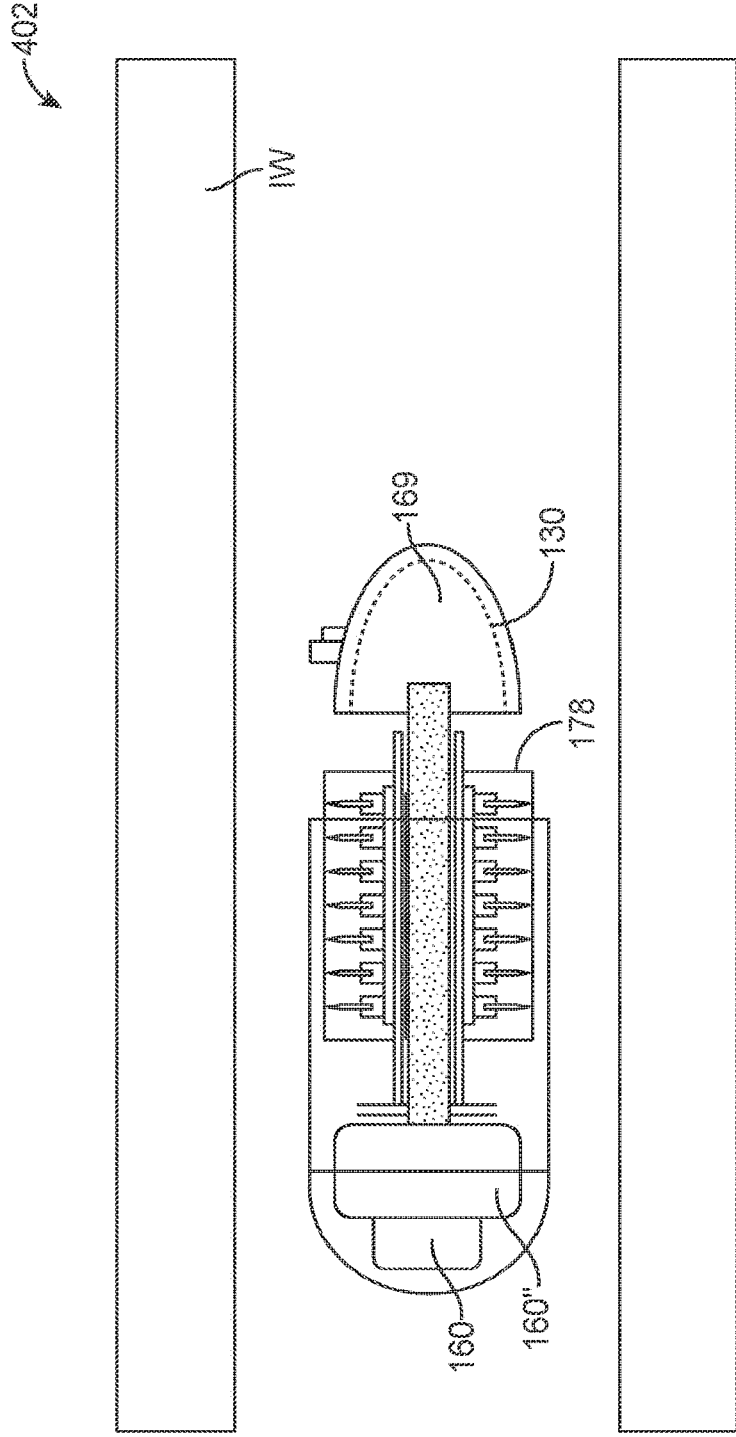

FIG. 20d

403

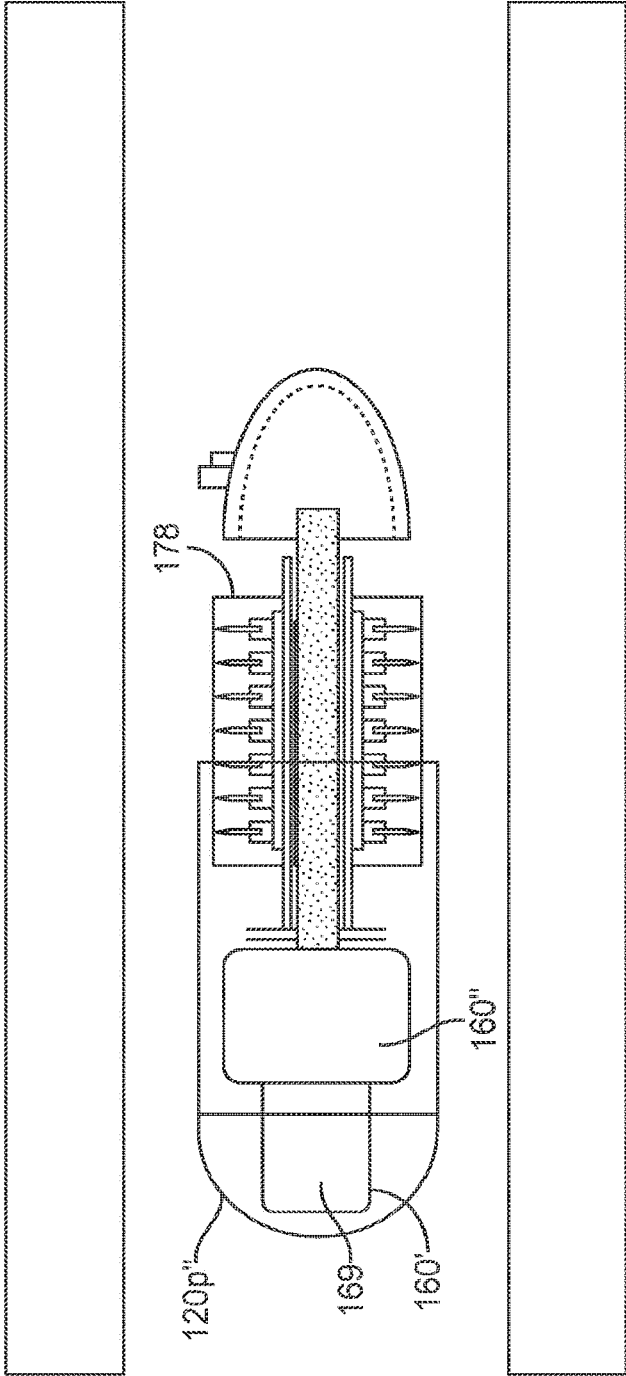

FIG. 20e

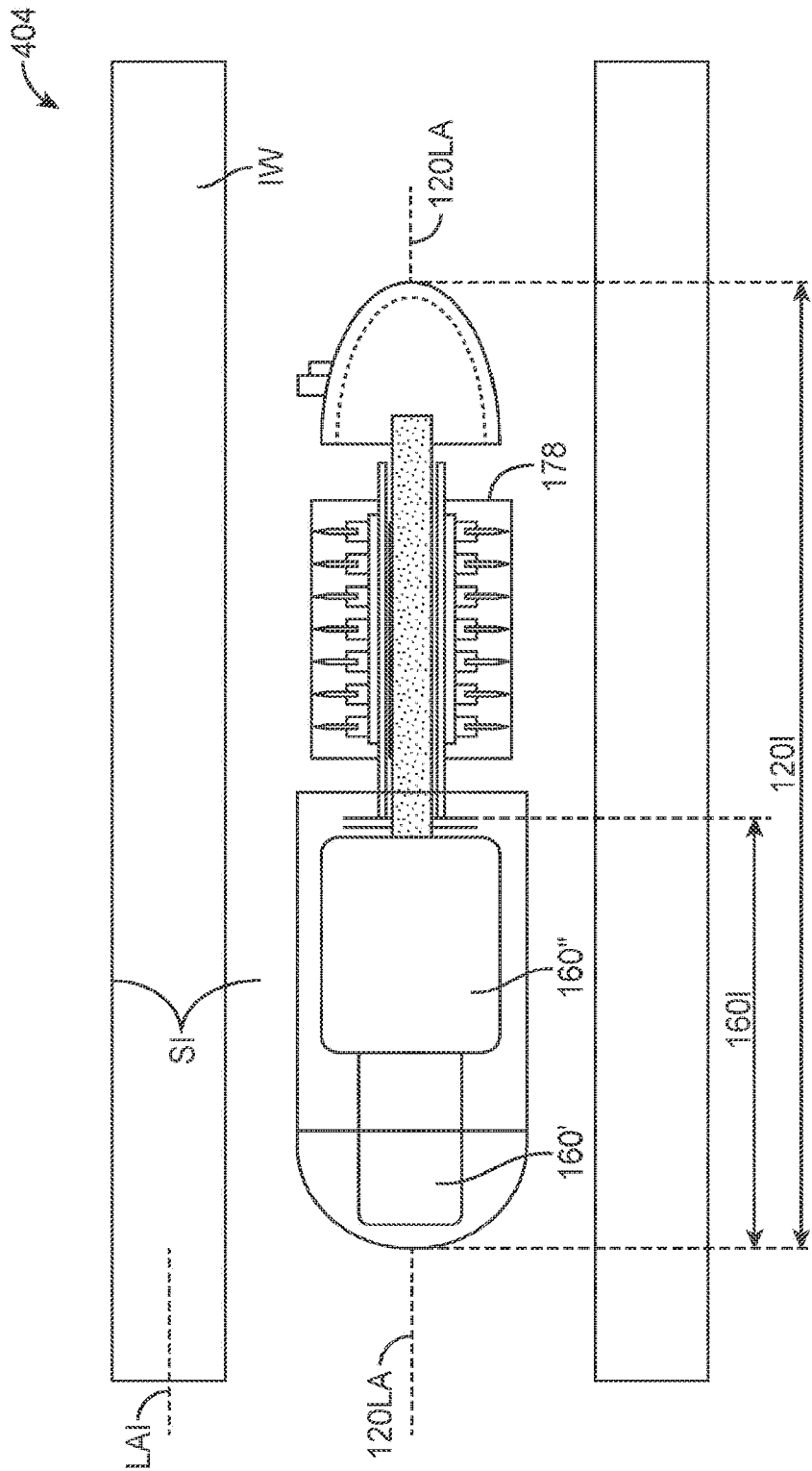

FIG. 20f

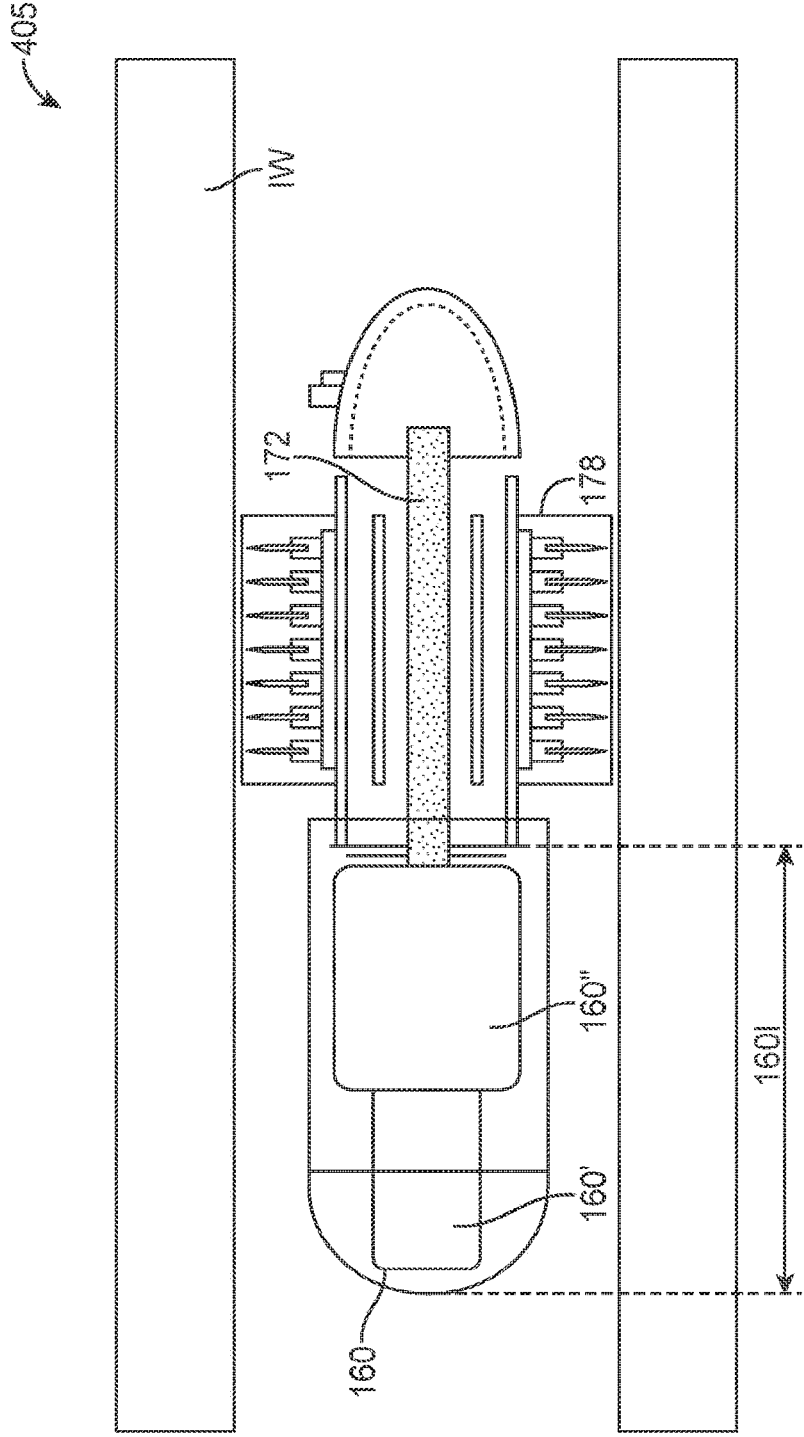

FIG. 20g

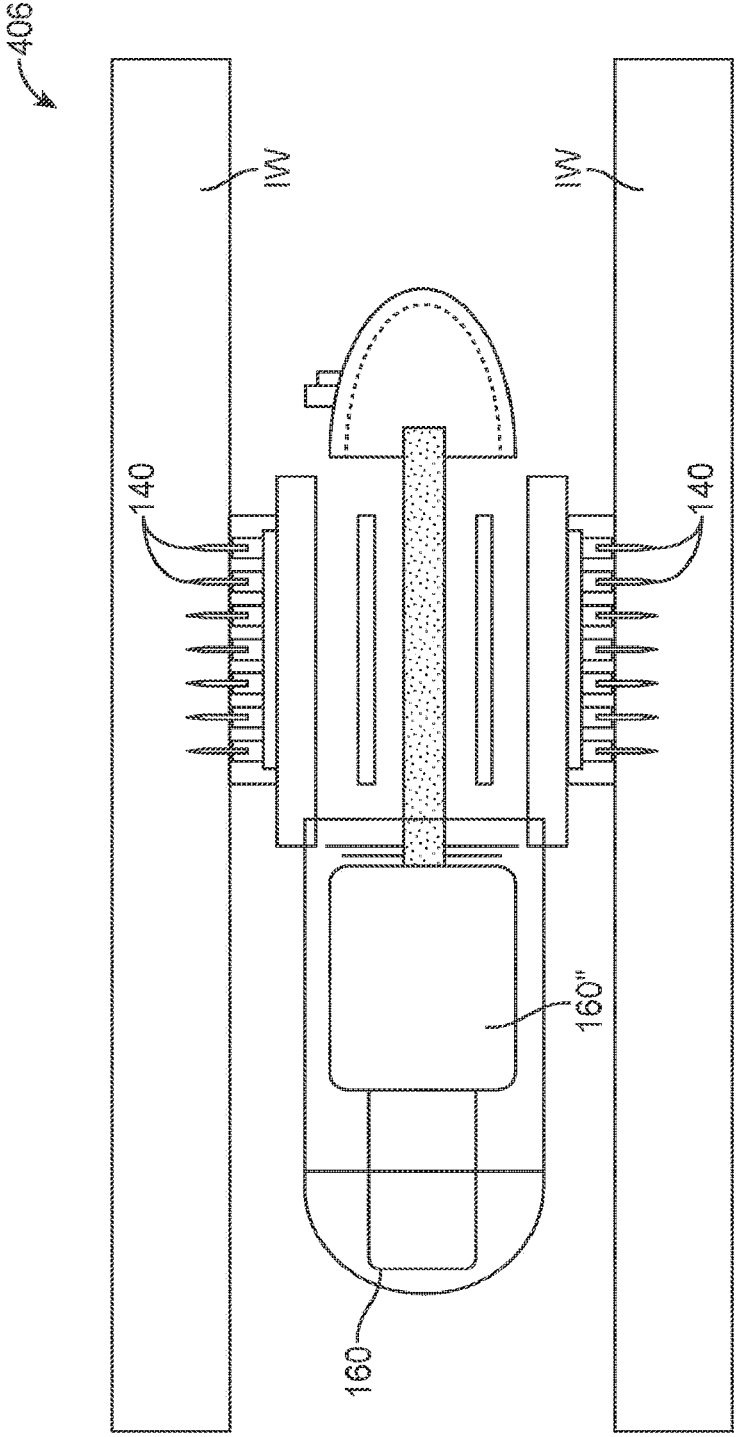

FIG. 20h

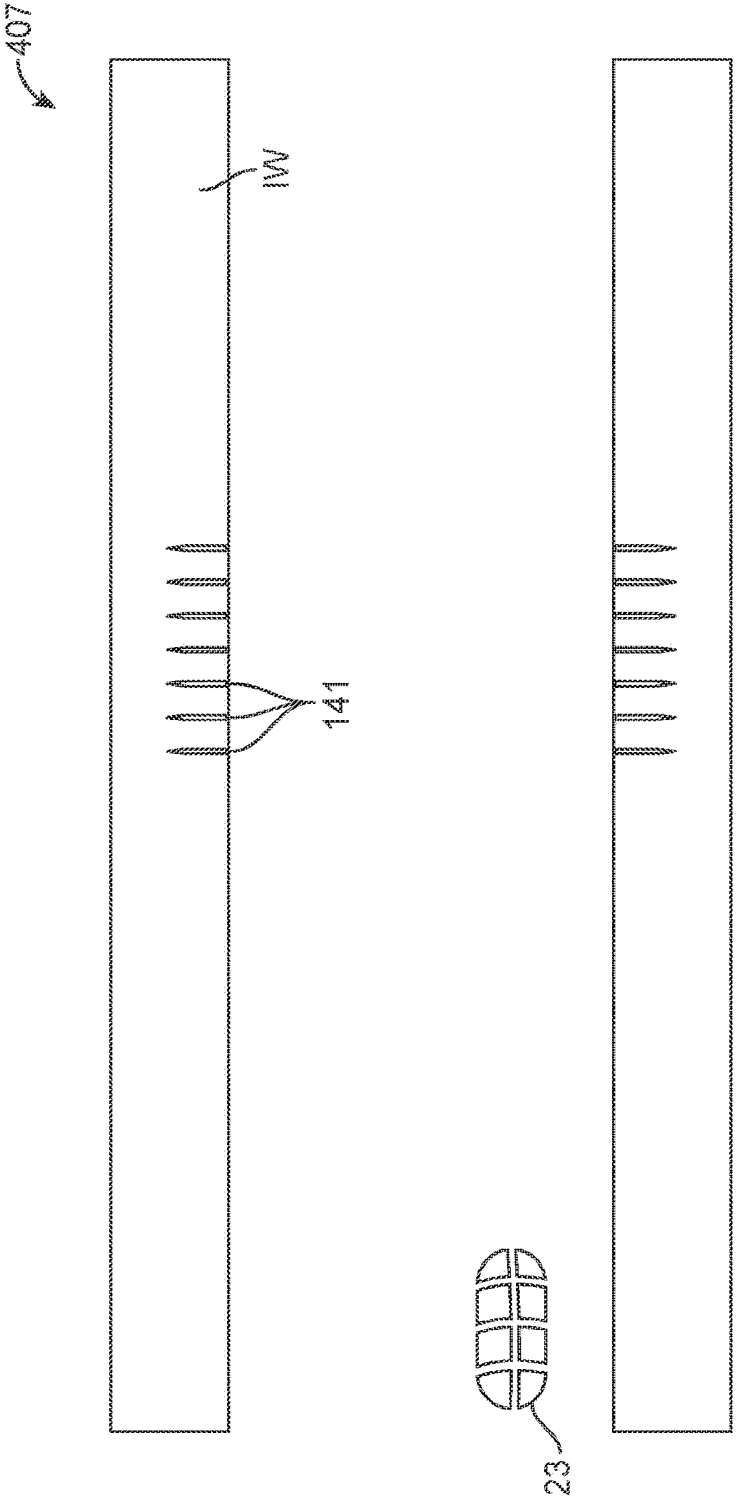

FIG. 20I

**THERAPEUTIC AGENT PREPARATIONS
FOR DELIVERY INTO A LUMEN OF THE
INTESTINAL TRACT USING A
SWALLOWABLE DRUG DELIVERY DEVICE**

**CROSS-REFERENCES TO RELATED
APPLICATIONS**

[0001] This application is a continuation of U.S. application Ser. No. 16/405,909, filed May 7, 2019, which is a continuation of U.S. patent application Ser. No. 15/824,976, filed Nov. 28, 2017, now U.S. Pat. No. 10,335,463; which is a continuation of U.S. patent application Ser. No. 13/538,793, filed Jun. 29, 2012, now U.S. Pat. No. 9,861,683; which claims the benefit of the following U.S. Provisional Applications: U.S. Provisional Application No. 61/571,632, filed on Jun. 29, 2011; and U.S. Provisional Application No. 61/571,641, filed Jun. 29, 2011; and U.S. patent application Ser. No. 13/538,793 is also a continuation in part of the following U.S. patent applications: U.S. patent application Ser. No. 12/978,233, filed on Dec. 23, 2010, now U.S. Pat. No. 8,721,620; U.S. patent application Ser. No. 12/978,164, filed on Dec. 23, 2010, now U.S. Pat. No. 8,759,284; and U.S. patent application Ser. No. 12/978,301, filed on Dec. 23, 2010, now U.S. Pat. No. 8,562,589; all of which are incorporated herein by reference in their entirety.

[0002] This application is also related to Attorney Docket No. 42197-715.201 which was filed Jun. 25, 2012, as U.S. application Ser. No. 13/532,589, which is incorporated by reference herein for all purposes.

BACKGROUND OF THE INVENTION

Field of the Invention

[0003] Embodiments of the invention relate to swallowable drug delivery devices. More specifically, embodiments of the invention relate to swallowable drug delivery devices for delivering drugs to the small intestine.

[0004] While there has been an increasing development of new drugs in recent years for the treatment of a variety of diseases, many have limited application because they cannot be given orally. This is due to a number of reasons including: poor oral toleration with complications including gastric irritation and bleeding; breakdown/degradation of the drug compounds in the stomach; and poor, slow or erratic absorption of the drug. Conventional alternative drug delivery methods such as intravenous and intramuscular delivery have a number of drawbacks including pain and risk of infection from a needle stick, requirements for the use of sterile technique and the requirement and associated risks of maintaining an IV line in a patient for an extended period of time. While other drug delivery approaches have been employed such as implantable drug delivery pumps, these approaches require the semi-permanent implantation of a device and can still have many of the limitations of IV delivery. Thus, there is a need for an improved method for delivery of drugs and other therapeutic agents, including a need for improved delivery of growth hormone for treatment of growth hormone deficiency and related disorders.

BRIEF SUMMARY OF THE INVENTION

[0005] Embodiments of the invention provide devices, systems, kits and methods for delivering drugs and other therapeutic agents to various locations in the body. Many

embodiments provide a swallowable device for delivering drugs and other therapeutic agents within the Gastrointestinal (GI) tract. Particular embodiments provide a swallowable device such as a capsule for delivering drugs and other therapeutic agents into the wall of the small intestine or other GI organ wall. Embodiments of the invention are particularly useful for the delivery of drugs and other therapeutic agents which are poorly absorbed, poorly tolerated and/or degraded within the GI tract. Further, embodiments of the invention can be used to deliver drugs which were previously only capable of or preferably delivered by intravenous or other form of parenteral administration including various non-vascular injected forms of administration such as intramuscular or subcutaneous injection.

[0006] In one aspect of the invention, the invention provides a therapeutic agent preparation for delivery into a wall of the intestinal tract, the preparation comprises a therapeutically effective dose of at least one therapeutic agent. The preparation has a shape and material consistency to be contained in a swallowable capsule or other device and delivered from the capsule into the intestinal wall to release the dose of therapeutic agent from within the intestinal wall.

[0007] In another embodiment, the invention provides a therapeutic agent preparation for delivery into a wall of the intestinal tract such as the wall of the small intestine, the preparation comprises a therapeutically effective dose of at least one therapeutic agent. The preparation is configured to be contained in a swallowable capsule and operably coupled to an actuator, expandable balloon or other device having a first configuration and a second configuration. The preparation is contained within the capsule in the first configuration and advanced out of the capsule and into the intestinal wall in the second configuration to deliver the therapeutic agent into the intestinal wall.

[0008] In other embodiments, the invention provides a method for delivering a therapeutic agent into the wall of the small intestine comprising swallowing a drug delivery device comprising a capsule, an actuator and an embodiment of the therapeutic agent preparation. The actuator is responsive to a condition in the small intestine such as pH so as to actuate delivery of the therapeutic agent preparation into the wall of the small intestine. In specific embodiments, the actuator can comprise a release element or coating on the capsule which is degraded by a selected pH in the small intestine. Once degraded, the element or coating initiates delivery of the therapeutic agent preparation by one or more delivery means such as the by expansion of one or more balloons that are operably coupled to tissue penetrating members that contain the therapeutic agent preparation and are configured to penetrate and be advanced into the intestinal wall upon expansion of the balloon. Once the tissue penetrating members are in the intestinal wall, they degrade to release the therapeutic agent into the bloodstream. Because the therapeutic agent preparation is delivered directly into the wall of the small intestine, the time period (described herein as C_{max}) for achieving the maximum concentration of the therapeutic agent in the bloodstream or other location in the body is shorter than a corresponding time period for achieving such a maximum concentration when the therapeutic agent is non-vascularly injected into the body such as by intramuscular or subcutaneous injection. In various embodiments, the time period for achieving C_{max} by insertion of the therapeutic preparation into the intestinal wall using one or more embodiments of the invention (such

as an embodiment of the swallowable device) can be 80%, 50%, 30%, 20 or even 10% of the time period for achieving a C_{max} through the use of a non-vascular injection of the therapeutic agent. In other embodiments, the C_{max} achieved by insertion of the therapeutic preparation into the intestinal wall using one or more embodiments of the invention, such as an embodiment of the swallowable device, can be greater than a C_{max} achieved by taking a convention oral form of the therapeutic agent (e.g., a pill) where the therapeutic agent is not inserted into the intestinal wall. In various embodiments, the C_{max} achieved by insertion of the therapeutic preparation into the intestinal wall using one or more embodiments of the invention (such as an embodiment of the swallowable device) can be 5, 10, 20, 30, 40, 50, 60, 70, 80 or even a 100 times greater than when the therapeutic agent is delivered in a pill or other oral form. In other related embodiments, the composition can be configured to produce a long-term release of therapeutic agent with a selectable $t_{1/2}$ that is the time period required for the concentration of the therapeutic agent in the bloodstream or other location in the body to reach half its original C_{max} value after having reached C_{max} . For example, the selectable $t_{1/2}$ may be 6, or 9, or 12, or 15 or 18, or 24 hours.

[0009] In another aspect, the invention provides a swallowable device for delivering a drug or other therapeutic agent preparation into the wall of the small or large intestine or other organ of the gastro-intestinal tract. The device comprises a capsule sized to be swallowed and pass through the gastro-intestinal tract, a deployable aligner positioned within the capsule for aligning a longitudinal axis of the capsule with the a longitudinal axis of the small intestine, a delivery mechanism for delivering the therapeutic agent into the intestinal wall and a deployment member for deploying at least one of the aligner or the delivery mechanism. The capsule wall is degradable by contact with liquids in the GI tract but also may include an outer coating or layer which only degrades in the higher pH's found in the small intestine, and serves to protect the underlying capsule wall from degradation within the stomach before the capsule reaches the small intestine at which point the drug delivery is initiated by degradation of the coating. In use, such materials allow for the targeted delivery of a therapeutic agent in a selected portion of the GI tract such as the small intestine. Suitable outer coatings can include various enteric coatings such as various co-polymers of methacrylic acid and ethyl acetate.

[0010] Another embodiment of the capsule includes at least one guide tube, one or more tissue penetrating members positioned in the at least one guide tube, a delivery member and an actuating mechanism. The tissue penetrating member will typically comprise a hollow needle or other like structure and will have a lumen and a tissue penetrating end for penetrating a selectable depth into the intestinal wall. In various embodiments, the device can include a second and a third tissue penetrating member with additional numbers contemplated. Each tissue penetrating member can include the same or a different drug. In preferred embodiments having multiple tissue penetrating members, the tissue penetrating members can be symmetrically distributed around the perimeter of the capsule so as to anchor the capsule onto the intestinal wall during delivery of drug. In some embodiments, all or a portion of the tissue penetrating member (e.g., the tissue penetrating end) can be fabricated from the drug preparation itself. In these and related embodi-

ments, the drug preparation can have a needle or dart-like structure (with or without barbs) configured to penetrate and be retained in the intestinal wall.

[0011] The tissue penetrating member can be fabricated from various biodegradable materials (e.g., PLGA, maltose or other sugars) so as to degrade within the small intestine and thus provide a fail-safe mechanism for detaching the tissue penetrating member from the intestinal wall should this component become retained in the intestinal wall. Additionally, in these and related embodiments, selectable portions of the capsule can be fabricated from such biodegradable materials so as to allow the entire device to controllably degrade into smaller pieces. Such embodiments facilitate passage and excretion of the devices through the GI tract. In particular embodiments, the capsule can include seams of biodegradable material which controllably degrade to produce capsule pieces of a selectable size and shape to facilitate passage through the GI tract. The seams can be pre-stressed, perforated or otherwise treated to accelerate degradation. The concept of using biodegradable seams to produce controlled degradation of a swallowable device in the GI tract can also be applied to other swallowable devices such as swallowable cameras to facilitate passage through the GI tract and reduce the likelihood of a device becoming stuck in the GI tract.

[0012] The delivery member is configured to advance the drug from the capsule through the tissue penetrating member lumen and into the intestinal wall. Typically, at least a portion of the delivery member is advanceable within the tissue penetrating member lumen. The delivery member can have a piston or like structure sized to fit within the delivery member lumen. The distal end of the delivery member (the end which is advanced into tissue) can have a plunger element which advances the drug within tissue penetrating member lumen and also forms a seal with the lumen. The plunger element can be integral or attached to the delivery member. Preferably, the delivery member is configured to travel a fixed distance within the needle lumen so as to deliver a fixed or metered dose of drug into the intestinal wall. This can be achieved by one or more of the selection of the diameter of the delivery member (e.g., the diameter can be distally tapered), the diameter of the tissue penetrating member (which can be narrowed at its distal end), use of a stop, and/or the actuating mechanism. For embodiments of the device having a tissue penetrating member fabricated from drug (e.g., a drug dart), the delivery member is adapted to advance the dart out of the capsule and into tissue.

[0013] The delivery member and tissue penetrating member can be configured for the delivery of liquid, semi-liquid or solid forms of drug or all three. Solid forms of drug can include both powder and pellet. Semi liquid can include a slurry or paste. The drug can be contained within a cavity of the capsule, or in the case of the liquid or semi-liquid, within an enclosed reservoir. In some embodiments, the capsule can include a first second, or a third drug (or more). Such drugs can be contained within the tissue penetrating member lumen (in the case of solids or powder) or in separate reservoirs within the capsule body.

[0014] The actuating mechanism can be coupled to at least one of the tissue penetrating member or the delivery member. The actuating mechanism is configured to advance the tissue penetrating member a selectable distance into the intestinal wall as well as advance the delivery member to deliver the drug and then withdraw the tissue penetrating

member from the intestinal wall. In various embodiments, the actuating mechanism can comprise a preloaded spring mechanism which is configured to be released by the release element. Suitable springs can include both coil (including conical shaped springs) and leaf springs with other spring structures also contemplated. In particular embodiments, the spring can be cone shaped to reduce the length of the spring in the compressed state even to the point where the compressed length of the spring is about the thickness of several coils (e.g., two or three) or only one coil.

[0015] In particular embodiments the actuating mechanism comprises a spring, a first motion converter, and a second motion converter and a track member. The release element is coupled to the spring to retain the spring in a compressed state such that degradation of the release element releases the spring. The first motion converter is configured to convert motion of the spring to advance and withdraw the tissue penetrating element in and out of tissue. The second motion converter is configured to convert motion of the spring to advance the delivery member into the tissue penetrating member lumen. The motion converters are pushed by the spring and ride along a rod or other track member which serves to guide the path of the converters. They engage the tissue penetrating member and/or delivery member (directly or indirectly) to produce the desired motion. They are desirably configured to convert motion of the spring along its longitudinal axis into orthogonal motion of the tissue penetrating member and/or delivery member though conversion in other directions is also contemplated. The motion converters can have a wedge, trapezoidal or curved shape with other shapes also contemplated. In particular embodiments, the first motion converter can have a trapezoidal shape and include a slot which engages a pin on the tissue penetrating member that rides in the slot. The slot can have a trapezoidal shape that mirrors or otherwise corresponds to the overall shape of the converter and serves to push the tissue penetrating member during the upslope portion of the trapezoid and then pull it back during the down slope portion. In one variation, one or both of the motion converters can comprise a cam or cam like device which is turned by the spring and engages the tissue penetrating and/or delivery member.

[0016] In other variations, the actuating mechanism can also comprise an electro-mechanical device/mechanism such as a solenoid or a piezoelectric device. In one embodiment, the piezoelectric device can comprise a shaped piezoelectric element which has a non-deployed and deployed state. This element can be configured to go into the deployed state upon the application of a voltage and then return to the non-deployed state upon the removal of the voltage. This and related embodiments allow for a reciprocating motion of the actuating mechanism so as to both advance the tissue penetrating member and then withdraw it.

[0017] The release element is coupled to at least one of the actuating mechanism or a spring coupled to the actuating mechanism. In particular embodiments, the release element is coupled to a spring positioned within the capsule so as to retain the spring in a compressed state. Degradation of the release element releases the spring to actuate the actuation mechanism. In many embodiments, the release element comprises a material configured to degrade upon exposure to chemical conditions in the small or large intestine such as pH. Typically, the release element is configured to degrade upon exposure to a selected pH in the small intestine, e.g.,

7.0, 7.1, 7.2, 7.3, 7.4, 8.0 or greater. However, it can also be configured to degrade in response to other conditions in the small intestine. In particular embodiments, the release element can be configured to degrade in response to particular chemical conditions in the fluids in the small intestine such as those which occur after ingestion of a meal (e.g., a meal high in fats or proteins).

[0018] Biodegradation of the release element from one or more conditions in the small intestine (or other location in the GI tract) can be achieved by selection of the materials for the release element, the amount of cross linking of those materials as well as the thickness and other dimensions of the release elements. Lesser amounts of cross linking and or thinner dimensions can increase the rate of degradation and vice versa. Suitable materials for the release element can comprise biodegradable materials such as various enteric materials which are configured to degrade upon exposure to the higher pH or other condition in the small intestine. The enteric materials can be copolymerized or otherwise mixed with one or more polymers to obtain a number of particular material properties in addition to biodegradation. Such properties can include without limitation stiffness, strength, flexibility and hardness.

[0019] In particular embodiments, the release element can comprise a film or plug that fits over or otherwise blocks the guide tube and retains the tissue penetrating member inside the guide tube. In these and related embodiments, the tissue penetrating member is coupled to a spring loaded actuating mechanism such that when the release element is degraded sufficiently, it releases the tissue penetrating member which then springs out of the guide tube to penetrate into the intestinal wall. In other embodiments, the release element can be shaped to function as a latch which holds the tissue penetrating element in place. In these and related embodiments, the release element can be located on the exterior or the interior of the capsule. In the interior embodiments, the capsule and guide tubes are configured to allow for the ingress of intestinal fluids into the capsule interior to allow for the degradation of the release element.

[0020] In some embodiments, the actuating mechanism can be actuated by means of a sensor, such as a pH or other chemical sensor which detects the presence of the capsule in the small intestine and sends a signal to the actuating mechanism (or to an electronic controller coupled to the actuating mechanism to actuate the mechanism). Embodiments of a pH sensor can comprise an electrode-based sensor or it can be a mechanically-based sensor such as a polymer which shrinks or expands upon exposure to the pH or other chemical conditions in the small intestine. In related embodiments, an expandable/contractible sensor can also comprise the actuating mechanism itself by using the mechanical motion from the expansion or contraction of the sensor.

[0021] According to another embodiment for detecting that the device is in the small intestine (or other location in the GI tract), the sensor can comprise a strain gauge or other pressure/force sensor for detecting the number of peristaltic contractions that the capsule is being subject to within a particular location in the intestinal tract. In these embodiments, the capsule is desirably sized to be gripped by the small intestine during a peristaltic contraction). Different locations within the GI tract have different number of peristaltic contractions. The small intestine has between 12 to 9 contractions per minute with the frequency decreasing

down the length of the intestine. Thus, according to one or more embodiments detection of the number of peristaltic contractions can be used to not only determine if the capsule is in the small intestine but the relative location within the intestine as well.

[0022] As an alternative or supplement to internally activated drug delivery, in some embodiments, the user may externally activate the actuating mechanism to deliver drug by means of RF, magnetic or other wireless signaling means known in the art. In these and related embodiments, the user can use a handheld device (e.g., a hand held RF device) which not only includes signaling means, but also means for informing the user when the device is in the small intestine or other location in the GI tract. The later embodiment can be implemented by including an RF transmitter on the swallowable device to signal to the user when the device is in the small intestine or other location (e.g., by signaling an input from the sensor). The same handheld device can also be configured to alter the user when the actuating mechanism has been activated and the selected drug(s) delivered. In this way, the user is provided confirmation that the drug has been delivered. This allows the user to take other appropriate drugs/therapeutic agents as well as make other related decisions (e.g., for diabetics to eat a meal or not and what foods should be eaten). The handheld device can also be configured to send a signal to the swallowable device to over-ride the actuating mechanism and so prevent, delay or accelerate the delivery of drug. In use, such embodiments allow the user to intervene to prevent, delay or accelerate the delivery of drug based upon other symptoms and/or patient actions (e.g., eating a meal, deciding to go to sleep, exercise etc).

[0023] The user may also externally activate the actuating mechanism at a selected time period after swallowing the capsule. The time period can be correlated to a typical transit time or range of transit times for food moving through the user's GI tract to a particular location in the tract such as the small intestine.

[0024] Another aspect of the inventions provides therapeutic agent preparations for delivery into the wall of the small intestine (or other wall in the intestinal tract) using embodiments of the swallowable device described herein. The preparation comprises a therapeutically effective dose of at least one therapeutic agent. It may comprise a solid, liquid or combination of both and can include one or more pharmaceutical excipients. The preparation has a shape and material consistency to be contained in embodiments of the swallowable capsule, delivered from the capsule into the intestinal wall and degrade within the wall to release the dose of therapeutic agent. The preparation may also have a selectable surface area to volume ratio so as enhance or otherwise control the rate of degradation of the preparation in the wall of the small intestine or other body lumen. In various embodiments, the preparation can be configured to be coupled to an actuator such as a release element or actuation mechanism which has a first configuration in which the preparation is contained in the capsule and a second configuration in which the preparation is advanced out of the capsule and into the wall of the small intestine. The dose of the drug or other therapeutic agent in the preparation can be titrated downward from that which would be required for conventional oral delivery methods so that potential side effects from the drug can be reduced.

[0025] Typically, though not necessarily, the preparation will be shaped and otherwise configured to be contained in the lumen of a tissue penetrating member, such as a hollow needle which is configured to be advanced out of the capsule and into the wall of the small intestine. The preparation itself may comprise a tissue penetrating member configured to be advanced into the wall of the small intestine or other lumen in the intestinal tract.

[0026] Another aspect of the invention provides methods for the delivery of drugs and the therapeutic agents into the walls of the GI tract using embodiments of the swallowable drug delivery devices. Such methods can be used for the delivery of therapeutically effective amounts of a variety of drugs and other therapeutic agents. These include a number of large molecule peptides and proteins which would otherwise require injection due to chemical breakdown in the stomach e.g., growth hormone, parathyroid hormone, insulin, interferons and other like compounds. Suitable drugs and other therapeutic agents which can be delivered by embodiments of invention include various chemotherapeutic agents (e.g., interferon), antibiotics, antivirals, insulin and related compounds, glucagon like peptides (e.g., GLP-1, exenatide), parathyroid hormones, growth hormones (e.g., IFG and other growth factors), anti-seizure agents, immune suppression agents and anti-parasitic agents such as various anti-malarial agents. The dosage of the particular drug can be titrated for the patient's weight, age, condition or other parameter.

[0027] In various method embodiments, embodiments of the drug swallowable drug delivery device can be used to deliver a plurality of drugs for the treatment of multiple conditions or for the treatment of a particular condition (e.g., a mixture of protease inhibitors for treatment HIV AIDS). In use, such embodiments allow a patient to forgo the necessity of having to take multiple medications for a particular condition or conditions. Also, they provide a means for facilitating that a regimen of two or more drugs is delivered and absorbed into the small intestine and thus, the blood stream at about the same time. Due to differences in chemical makeup, molecular weight, etc, drugs can be absorbed through the intestinal wall at different rates, resulting in different pharmacokinetic distribution curves. Embodiments of the invention address this issue by injecting the desired drug mixtures at about the same time. This in turn improves pharmacokinetics and thus, the efficacy of the selected mixture of drugs.

[0028] Further details of these and other embodiments and aspects of the invention are described more fully below, with reference to the attached drawing figures.

BRIEF DESCRIPTION OF THE DRAWINGS

[0029] FIG. 1a is a lateral viewing showing an embodiment of a swallowable drug delivery device.

[0030] FIG. 1b is a lateral viewing showing an embodiment of a system including a swallowable drug delivery device.

[0031] FIG. 1c is a lateral viewing showing an embodiment of a kit including a swallowable drug delivery device and a set of instructions for use.

[0032] FIG. 1d is a lateral viewing showing an embodiment of a swallowable drug delivery device including a drug reservoir.

[0033] FIG. 2 is a lateral view illustrating an embodiment of the swallowable drug delivery device having a spring loaded actuation mechanism for advancing tissue penetrating members into tissue.

[0034] FIG. 3 is a lateral view illustrating an embodiment of the swallowable drug delivery device having a spring loaded actuation mechanism having a first motion converter.

[0035] FIG. 4 is a lateral view illustrating an embodiment of the swallowable drug delivery device having a spring loaded actuation mechanism having first and a second motion converter.

[0036] FIG. 5 is a perspective view illustrating engagement of the first and second motion converters with the tissue penetrating member and delivery members.

[0037] FIG. 6 is a cross sectional view illustrating an embodiment of the swallowable drug delivery device having a single tissue penetrating member and an actuating mechanism for advancing the tissue penetrating member.

[0038] FIG. 7a is a cross sectional view illustrating an embodiment of the swallowable drug delivery device having multiple tissue penetrating members and an actuating mechanism for advancing the tissue penetrating members.

[0039] FIG. 7b is a cross sectional view illustrating deployment of the tissue penetrating members of the embodiment of FIG. 7a to deliver medication to a delivery site and anchor the device in the intestinal wall during delivery.

[0040] FIGS. 8a-8c are side view illustrating positioning of the drug delivery device in the small intestine and deployment of the tissue penetrating members to deliver drug; FIG. 8a shows the device in the small intestine prior to deployment of the tissue penetrating members with the release element in tact; FIG. 8b shows the device in the small intestine with the release element degraded and the tissue penetrating elements deployed; and FIG. 8c shows the device in the small intestine with the tissue penetrating elements retracted and the drug delivered.

[0041] FIG. 9a shows an embodiment of a swallowable drug delivery device including a capsule having bio-degradable seams positioned to produce controlled degradation of the capsule in the GI tract.

[0042] FIG. 9b shows the embodiment of FIG. 9a after having been degraded in the GI tract into smaller pieces.

[0043] FIG. 10 shows an embodiment of a capsule having biodegradable seams including pores and/or perforations to accelerate biodegradation of the capsule.

[0044] FIG. 11 is a lateral viewing illustrating use of an embodiment of a swallowable drug delivery device including transit of device in the GI tract and operation of the device to deliver drug.

[0045] FIGS. 12a and 12b are lateral view illustrating an embodiment of a capsule for the swallowable drug delivery device including a cap and a body coated with pH sensitive biodegradable coatings, FIG. 12a shows the capsule in an unassembled state and FIG. 12b in an assembled state

[0046] FIGS. 13a and 13b illustrate embodiments of unfolded multi balloon assemblies containing a deployment balloon, an aligner balloon, a delivery balloon and assorted connecting tubes; FIG. 13a shows an embodiment of the assembly for a single dome configuration of the deployment balloon; and FIG. 13b shows an embodiment of the assembly for dual dome configuration of the deployment balloon; and.

[0047] FIG. 13c is a perspective views illustrating embodiments of a nested balloon configuration which can be used for one or more embodiments of the balloons described herein including the aligner balloon.

[0048] FIGS. 14a-14c are lateral views illustrating embodiments of a multi compartment deployment balloon; FIG. 14a shows the balloon in a non-inflated state with the separation valve closed; FIG. 14b shows the balloon with valve open and mixing of the chemical reactants; and FIG. 14c shows the balloon in an inflated state.

[0049] FIGS. 15a-15g are lateral views illustrating a method for folding of the multiple balloon assembly, the folding configuration in each figure applies to both single and dual dome configurations of the deployment balloon, with the exception that FIG. 15c, pertains to a folding step unique to dual dome configurations; and FIG. 15d, pertains to the final folding step unique to dual dome configurations; FIG. 15e, pertains to a folding step unique to single dome configurations; and FIGS. 15f and 15g are orthogonal views pertaining to the final folding step unique to single dome configurations.

[0050] FIGS. 16a and 16b are orthogonal views illustrating embodiments of the final folded multi balloon assembly with the attached delivery assembly.

[0051] FIGS. 17a and 17b are orthogonal transparent views illustrating embodiments of the final folded multi balloon assembly inserted into the capsule.

[0052] FIG. 18a is a side view of an embodiment of the tissue penetrating member.

[0053] FIG. 18b is a bottom view of an embodiment of the tissue penetrating member illustrating placement of the tissue retaining features.

[0054] FIG. 18c is a side view of an embodiment of the tissue penetrating member having a trocar tip and inverted tapered shaft.

[0055] FIG. 18d is a side view of an embodiment of the tissue penetrating member having a separate drug containing section.

[0056] FIGS. 18e and 18f are side views showing assembly of an embodiment of a tissue penetrating member having a shaped drug containing section. FIG. 18e shows the tissue penetrating member and shaped drug section prior to assembly; and FIG. 18f after assembly.

[0057] FIG. 19 provides assorted views of the components and steps used to assemble an embodiment of the delivery assembly.

[0058] FIGS. 20a-20i provides assorted views illustrating a method of operation of swallowable device to deliver medication to the intestinal wall.

DETAILED DESCRIPTION OF THE INVENTION

[0059] Embodiments of the invention provide devices, systems and methods for delivering medications in to various locations in the body. As used herein, the term “medication” refers to a medicinal preparation in any form which can include drugs or other therapeutic agents as well as one or more pharmaceutical excipients. Many embodiments provide a swallowable device for delivering medication within the GI tract. Particular embodiments provide a swallowable device such as a capsule for delivering medications to the wall of the small intestine or other GI organ. As used herein, “GI tract” refers to the esophagus, stomach, small intestine, large intestine and anus, while “Intestinal tract”

refers to the small and large intestine. Various embodiments of the invention can be configured and arranged for delivery of medication into the intestinal tract as well as the entire GI tract.

[0060] Referring now to FIGS. 1-11, an embodiment of an device 10 for the delivery of medication 100 to a delivery site DS in the intestinal tract such as the wall of the small intestine, comprises a capsule 20 including at least one guide tube 30, one or more tissue penetrating members 40 positioned or otherwise advanceable in the at least one guide tube, a delivery member 50, an actuating mechanism 60 and release element 70. Medication 100, also described herein as preparation 100, typically comprises at least one drug or therapeutic agent 101 and may include one or more pharmaceutical excipients known in the art. Collectively, one or more of delivery member 50 and mechanism 60 may comprise a means for delivery of medication 100 into a wall of the intestinal tract. Other delivery means contemplated herein include one or more expandable balloons (e.g., delivery balloon 172) or other expandable device/member described herein.

[0061] Device 10 can be configured for the delivery of liquid, semi-liquid or solid forms of medication 100 or all three. Solid forms of medication/preparation 100 can include both powder or pellet. Semi liquid forms can include a slurry or paste. Whatever the form, preparation 100 desirably has a shape and material consistency allowing the medication to be advanced out of the device, into the intestinal wall (or other luminal wall in the GI tract) and then degrade in the intestinal wall to release the drug or other therapeutic agent 101. The material consistency can include one or more of the hardness, porosity and solubility of the preparation (in body fluids). The material consistency can be achieved by one or more of the following: i) the compaction force used to make the preparation; ii) the use of one or more pharmaceutical disintegrants known in the art; iii) use of other pharmaceutical excipients; iv) the particle size and distribution of the preparation (e.g., micronized particles); and v) use of micronizing and other particle formation methods known in the art. Suitable shapes for preparation 100 can include cylindrical, cubical, rectangular, conical, spherical, hemispherical and combinations thereof. Also, the shape can be selected so as to define a particular surface area and volume of preparation 100 and thus, the ratio between the two. The ratio of surface area to volume can in turn, be used to achieve a selected rate of degradation within the intestinal or other lumen wall within the GI tract. Larger ratios (e.g., larger amounts of surface area per unit volume) can be used to achieve faster rates of degradation and vice versa. In particular embodiments, the surface area to volume ratio can be in the range of about 1:1 to 100:1, with specific embodiments of 2:1, 5:1, 20:1, 25:1, 50:1 and 75:1. Preparation/medication 100 will typically be pre-packed within a lumen 44 of tissue penetrating members 40, but can also be contained at another location within an interior 24 of capsule 20, or in the case of a liquid or semi-liquid, within an enclosed reservoir 27. The medication can be pre-shaped to fit into the lumen or packed for example, in a powder form. Typically, the device 10 will be configured to deliver a single drug 101 as part of medication 100. However in some embodiments, the device 10 can be configured for delivery of multiple drugs 101 including a first second, or a third drug which can be compounded into a single or multiple medications 100. For embodiments having multiple medications/

drugs, the medications can be contained in separate tissue penetrating members 40 or within separate compartments or reservoirs 27 within capsule 20. In another embodiment, a first dose 102 of medication 100 containing a first drug 101 can be packed into the penetrating member(s) 40 and a second dose 103 of medication 100 (containing the same or a different drug 101) can be coated onto the surface 25 of capsule as is shown in the embodiment of FIG. 1b. The drugs 101 in the two doses of medication 102 and 103 can be the same or different. In this way, a bimodal pharmacokinetic release of the same or different drugs can be achieved. The second dose 103 of medication 100 can have an enteric coating 104 to ensure that it is released in the small intestine and achieve a time release of the medication 100 as well. Enteric coating 104 can include one or more enteric coatings described herein or known in the art.

[0062] A system 11 for delivery of medication 100 into the wall of the small intestine or other location within the GI tract, may comprise device 10, containing one or more medications 100 for the treatment of a selected condition or conditions. In some embodiments, the system may include a hand held device 13, described herein for communicating with device 10 as is shown in the embodiment of FIG. 1b. System 11 may also be configured as a kit 14 including system 11 and a set of instructions for use 15 which are packaged in packaging 12 as is shown in the embodiment of FIG. 1c. The instructions can indicate to the patient when to take the device 10 relative to one or more events such as the ingestion of a meal or a physiological measurement such as blood glucose, cholesterol, etc. In such embodiments, kit 14 can include multiple devices 10 containing a regimen of medications 100 for a selected period of administration, e.g., a day, week, or multiple weeks depending upon the condition to be treated.

[0063] Capsule 20 is sized to be swallowed and pass through the intestinal tract. The size can also be adjusted depending upon the amount of drug to be delivered as well as the patient's weight and adult vs. pediatric applications. Capsule 20 includes an interior volume 24 and an outer surface 25 having one or more apertures 26 sized for guide tubes 30. In addition to the other components of device 10, (e.g., the actuation mechanism etc.) the interior volume can include one or more compartments or reservoirs 27. One or more portions of capsule 20 can be fabricated from various biocompatible polymers known in the art, including various biodegradable polymers which in a preferred embodiment can comprise PLGA (polylactic-co-glycolic acid). Other suitable biodegradable materials include various enteric materials described herein as well as lactide, glycolide, lactic acid, glycolic acid, para-dioxanone, caprolactone, trimethylene carbonate, caprolactone, blends and copolymers thereof. As is described in further detail herein, in various embodiments, capsule 20 can include seams 22 of bio-degradable material so as to controllably degrade into smaller pieces 23 which are more easily passed through the intestinal tract. Additionally, in various embodiments, the capsule can include various radio-opaque or echogenic materials for location of the device using fluoroscopy, ultrasound or other medical imaging modality. In specific embodiments, all or a portion of the capsule can include radio-opaque/echogenic markers 20m as is shown in the embodiment of FIGS. 1a and 1b. In use, such materials not

only allow for the location of device **10** in the GI tract, but also allow for the determination of transit times of the device through the GI tract.

[0064] In preferred embodiments, tissue penetrating members **40** are positioned within guide tubes **30** which serve to guide and support the advancement of members **40** into tissue such as the wall of the small intestine or other portion of the GI tract. The tissue penetrating members **40** will typically comprise a hollow needle or other like structure and will have a lumen **44** and a tissue penetrating end **45** for penetrating a selectable depth into the intestinal wall IW. Member **40** may also include a pin **41** for engagement with a motion converter **90** described herein. The depth of penetration can be controlled by the length of member **40**, the configuration of motion converter **90** described herein as well as the placement of a stop or flange **40s** on member **40** which can, in an embodiment, correspond to pin **41** described herein. Medication **100** will typically be delivered into tissue through lumen **44**. In many embodiments, lumen **44** is pre-packed with the desired medication **100** which is advanced out of the lumen using delivery member **50** or other advancement means (e.g. by means of force applied to a collapsible embodiment of member **40**). As an alternative, medication **100** can be advanced into lumen **44** from another location/compartments in capsule **20**. In some embodiments, all or a portion of the tissue penetrating member **40** can be fabricated from medication **100** itself. In these and related embodiments, the medication can have a needle or dart-like structure (with or without barbs) configured to penetrate and be retained in the intestinal wall, such as the wall of the small intestine. The dart can be sized and shaped depending upon the medication, dose and desired depth of penetration into the intestinal wall. Medication **100** can be formed into darts, pellets or other shapes using various compression molding methods known in the pharmaceutical arts.

[0065] In various embodiments, device **10** can include a second **42** and a third **43** tissue penetrating member **40** as is shown in the embodiments of FIGS. *7a* and *7b.*, with additional numbers contemplated. Each tissue penetrating member **40** can be used to deliver the same or a different medication **100**. In preferred embodiments, the tissue penetrating members **40** can be substantially symmetrically distributed around the perimeter **21** of capsule **20** so as to anchor the capsule onto the intestinal wall IW during delivery of medications **100**. Anchoring capsule **20** in such a way reduces the likelihood that the capsule will be displaced or moved by peristaltic contractions occurring during delivery of the medication. In specific embodiments, the amount of anchoring force can be adjusted to the typical forces applied during peristaltic contraction of the small intestine. Anchoring can be further facilitated by configured some or all of tissue penetrating members **40** to have a curved or arcuate shape.

[0066] Delivery member **50** is configured to advance medication **100** through the tissue penetrating member lumen **44** and into the intestinal wall IW. Accordingly, at least a portion of the delivery member **50** is advanceable within the tissue penetrating member lumen **44** and thus member **50** has a size and shape (e.g., a piston like shape) configured to fit within the delivery member lumen **44**.

[0067] In some embodiments, the distal end **50d** of the delivery member (the end which is advanced into tissue) can have a plunger element **51** which advances the medication within the tissue penetrating member lumen **44** and also

forms a seal with the lumen. Plunger element **51** can be integral or attached to delivery member **50**. Preferably, delivery member **50** is configured to travel a fixed distance within the needle lumen **44** so as to deliver a fixed or metered dose of drug into the intestinal wall IW. This can be achieved by one or more of the selection of the diameter of the delivery member (e.g., the diameter can be distally tapered), the diameter of the tissue penetrating member (which can be narrowed at its distal end), use of a stop, and/or the actuating mechanism. However in some embodiments, the stroke or travel distance of member **50** can be adjusted in situ responsive to various factors such as one or more sensed conditions in the GI tract. In situ adjustment can be achieved through use of logic resource **29** (including controller **29c**) coupled to an electro-mechanical embodiment of actuating mechanism **60**. This allows for a variable dose of medication and/or variation of the distance the medication is injected into the intestinal wall.

[0068] Actuating mechanism **60** can be coupled to at least one of the tissue penetrating member **40** or delivery member **50**. The actuating mechanism is configured to advance tissue penetrating member **40** a selectable distance into the intestinal wall IW as well as advance the delivery member to deliver medication **100** and then withdraw the tissue penetrating member from the intestinal wall. In various embodiments, actuating mechanism **60** can comprise a spring loaded mechanism which is configured to be released by release element **70**. Suitable springs **80** can include both coil (including conical shaped springs) and leaf springs with other spring structures also contemplated. In particular embodiments, spring **80** can be substantially cone-shaped to reduce the length of the spring in the compressed state even to the point where the compressed length of the spring is about the thickness of several coils (e.g., two or three) or only one coil.

[0069] In particular embodiments actuating mechanism **60** can comprise a spring **80**, a first motion converter **90**, and a second motion converter **94** and a track member **98** as is shown in the embodiments of FIGS. *2*, *4* and *8a-8c*. The release element **70** is coupled to spring **80** to retain the spring in a compressed state such that degradation of the release element releases the spring. Spring **80** may be coupled to release element **70** by a latch or other connecting element **81**. First motion converter **90** is configured to convert motion of spring **80** to advance and withdraw the tissue penetrating member **40** in and out of the intestinal wall or other tissue. The second motion converter **94** is configured to convert motion of the spring **80** to advance the delivery member **50** into the tissue penetrating member lumen **44**. Motion converters **90** and **94** are pushed by the spring and ride along a rod or other track member **98** which fits into a track member lumen **99** of converter **90**. The track member **98** serves to guide the path of the converters **90**. Converters **90** and **94** engage the tissue penetrating member **40** and/or delivery member **50** (directly or indirectly) to produce the desired motion. They have a shape and other characteristics configured to convert motion of the spring **80** along its longitudinal axis into orthogonal motion of the tissue penetrating member **40** and/or delivery member **50** though conversion in other directions is also contemplated. The motion converters can have a wedge, trapezoidal or curved shape with other shapes also contemplated. In particular embodiments, the first motion converter **90** can have a trapezoidal shape **90t** and include a slot **93** which engages

a pin **41** on the tissue penetrating member that rides in the slot as is shown in the embodiments of FIGS. **2**, **3** and **4**. Slot **93** can also have a trapezoidal shape **93'** that mirrors or otherwise corresponds to the overall shape of converter **90**. Slot **93** serves to push the tissue penetrating member **40** during the upslope portion **91** of the trapezoid and then pull it back during the down slope portion **92**. In one variation, one or both of the motion converters **90** and **94** can comprise a cam or cam like device (not shown). The cam can be turned by spring **80** so as to engage the tissue penetrating and/or delivery members **40** and **50**. One or more components of mechanism **60** (as well as other components of device **10**) including motion converters **90** and **94** can be fabricated using various MEMS-based methods known in the art so as to allow for selected amounts of miniaturization to fit within capsule **10**. Also as is described herein, they can be formed from various biodegradable materials known in the art.

[0070] In other variations, the actuating mechanism **60** can also comprise an electro-mechanical device/mechanism such as a solenoid or a piezoelectric device. In one embodiment, a piezoelectric device used in mechanism **60** can comprise a shaped piezoelectric element which has a non-deployed and deployed state. This element can be configured to go into the deployed state upon the application of a voltage and then return to the non-deployed state upon the removal of the voltage or other change in the voltage. This and related embodiments allow for a reciprocating motion of the actuating mechanism **60** so as to both advance the tissue penetrating member and then withdraw it. The voltage for the piezoelectric element can be obtained generated using a battery or a piezoelectric based energy converter which generates voltage by mechanical deformation such as that which occurs from compression of the capsule **20** by a peristaltic contraction of the small intestine around the capsule. Further description of piezoelectric based energy converters is found in U.S. patent application Ser. No. 12/556,524 which is fully incorporated by reference herein for all purposes. In one embodiment, deployment of tissue penetrating members **40** can in fact be triggered from a peristaltic contraction of the small intestine which provides the mechanical energy for generating voltage for the piezoelectric element.

[0071] Release element **70** will typically be coupled to the actuating mechanism **60** and/or a spring coupled to the actuating mechanism; however, other configurations are also contemplated. In preferred embodiments, release element **70** is coupled to a spring **80** positioned within capsule **20** so as to retain the spring in a compressed state **85** as shown in the embodiment of FIG. **2**. Degradation of the release element **70** releases spring **80** to actuate actuation mechanism **60**. Accordingly, release element **70** can thus function as an actuator **70a** (actuator **70** may also include spring **80** and other elements of mechanism **60**). As is explained further below, release element **70**/actuator **70a** has a first configuration where the therapeutic agent preparation **100** is contained within capsule **20** and a second configuration where the therapeutic agent preparation is advanced from the capsule into the wall of the small intestine or other luminal wall in the intestinal tract.

[0072] In many embodiments, release element **70** comprises a material configured to degrade upon exposure to chemical conditions in the small or large intestine such as pH. Typically, release element **70** is configured to degrade

upon exposure to a selected pH in the small intestine, e.g., 7.0, 7.1, 7.2, 7.3, 7.4, 7.5, 7.6 8.0 or greater. The release element can also be configured to degrade within a particular range of pH such as, e.g., 7.0 to 7.5. In particular embodiments, the pH at which release element **70** degrades (defined herein as the degradation pH) can be selected for the particular drug to be delivered so as to release the drug at a location in small intestine which corresponds to the selected pH. Further, for embodiments of device **10** having multiple medications **100**, the device can include a first release element **70** (coupled to an actuating mechanism for delivering a first drug) configured to degrade at first pH and a second release element **70** (coupled to an actuating mechanism for delivering a second drug) configured to degrade at a second pH (with additional numbers of release elements contemplated for varying number of drugs).

[0073] Release element **70** can also be configured to degrade in response to other conditions in the small intestine (or other GI location). In particular embodiments, the release element **70** can be configured to degrade in response to particular chemical conditions in the fluids in the small intestine such as those which occur after ingestion of a meal (e.g., a meal containing fats, starches or proteins). In this way, the release of medication **100** can be substantially synchronized or otherwise timed with the digestion of a meal.

[0074] Various approaches are contemplated for biodegradation of release element **70**. In particular embodiments, biodegradation of release element **70** from one or more conditions in the small intestine (or other location in the GI tract) can be achieved by one or more of the following approaches: i) selection of the materials for the release element, ii) the amount of cross linking of those materials; and iii) the thickness and other dimensions of the release element. Lesser amounts of cross linking and or thinner dimensions can increase the rate of degradation and vice versa. Suitable materials for the release element can comprise biodegradable materials such as various enteric materials which are configured to degrade upon exposure to the higher pH in the intestines. Suitable enteric materials include, but are not limited to, the following: cellulose acetate phthalate, cellulose acetate trimellitate, hydroxypropyl methylcellulose phthalate, polyvinyl acetate phthalate, carboxymethylcellulose, co-polymerized methacrylic acid/methacrylic acid methyl esters as well as other enteric materials known in the art. The selected enteric materials can be copolymerized or otherwise combined with one or more other polymers to obtain a number of other particular material properties in addition to biodegradation. Such properties can include without limitation stiffness, strength, flexibility and hardness.

[0075] In alternative embodiments, the release element **70** can comprise a film or plug **70p** that fits over or otherwise blocks guide tubes **30** and retains the tissue penetrating member **40** inside the guide tube. In these and related embodiments, tissue penetrating member **40** is coupled to a spring loaded actuating mechanism such that when the release element is degraded sufficiently, it releases the tissue penetrating member which then springs out of the guide tube to penetrate into the intestinal wall. In still other embodiments, release element **70** can be shaped to function as a latch which holds the tissue penetrating member **40** in place. In these and related embodiments, the release element can be located on the exterior or the interior of capsule **20**. In the

latter case, capsule 20 and/or guide tubes 30 can be configured to allow for the ingress of intestinal fluids into the capsule interior to allow for the degradation of the release element.

[0076] In some embodiments, actuating mechanism 60 can be actuated by means of a sensor 67, such as a pH sensor 68 or other chemical sensor which detects the presence of the capsule in the small intestine. Sensor 67 can then send a signal to actuating mechanism 60 or to an electronic controller 29c coupled to actuating mechanism 60 to actuate the mechanism. Embodiments of a pH sensor 68 can comprise an electrode-based sensor or it can be a mechanically-based sensor such as a polymer which shrinks or expands upon exposure to a selected pH or other chemical conditions in the small intestine. In related embodiments, an expandable/contractible sensor 67 can also comprise the actuating mechanism 60 itself by using the mechanical motion from the expansion or contraction of the sensor.

[0077] According to another embodiment for detecting that the device in the small intestine (or other location in the GI tract), sensor 67 can comprise pressure/force sensor such as strain gauge for detecting the number of peristaltic contractions that capsule 20 is being subject to within a particular location in the intestinal tract (in such embodiments capsule 20 is desirably sized to be gripped by the small intestine during a peristaltic contraction). Different locations within the GI tract have different number of peristaltic contractions. The small intestine has between 12 to 9 contractions per minute with the frequency decreasing down the length of the intestine. Thus, according to one or more embodiments, detection of the number of peristaltic contractions can be used to not only determine if capsule 20 is in the small intestine, but the relative location within the intestine as well. In use, these and related embodiments allow for release of medication 100 at a particular location in the small intestine.

[0078] As an alternative or supplement to internally activated drug delivery (e.g., using a release element and/or sensor), in some embodiments, the user may externally activate the actuating mechanism 60 to deliver medication 100 by means of RF, magnetic or other wireless signaling means known in the art. In these and related embodiments, the user can use a handheld communication device 13 (e.g., a hand held RF device such as a cell phone) as is shown in the embodiment of FIG. 1b, to send a receive signals 17 from device 10. In such embodiments, swallowable device may include a transmitter 28 such as an RF transceiver chip or other like communication device/circuitry. Handheld device 13 may not only includes signaling means, but also means for informing the user when device 10 is in the small intestine or other location in the GI tract. The later embodiment can be implemented through the use of logic resources 29 (e.g., a processor 29) coupled to transmitter 28 to signal to detect and singe to the user when the device is in the small intestine or other location (e.g., by signaling an input from the sensor). Logic resources 29 may include a controller 29c (either in hardware or software) to control one or more aspects of the process. The same handheld device can also be configured to alert the user when actuating mechanism 60 has been activated and the selected medication 100 delivered (e.g., using processor 29 and transmitter 28). In this way, the user is provided confirmation that medication 100 has been delivered. This allows the user to take other appropriate drugs/therapeutic agents as well as make other related

decisions (e.g., for diabetics to eat a meal or not and what foods should be eaten). The handheld device can also be configured to send a signal to swallowable device 10 to over-ride actuating mechanism 60 and so prevent delay or accelerate the delivery of medication 100. In use, such embodiments allow the user to intervene to prevent, delay or accelerate the delivery of medication, based upon other symptoms and/or patient actions (e.g., eating a meal, deciding to go to sleep, exercise etc). The user may also externally activate actuating mechanism 60 at a selected time period after swallowing the capsule. The time period can be correlated to a typical transit time or range of transit times for food moving through the user's GI tract to a particular location in the tract such as the small intestine.

[0079] In particular embodiments, the capsule 20 can include seams 22 of biodegradable material which controllably degrade to produce capsule pieces 23 of a selectable size and shape to facilitate passage through the GI tract as is shown in the embodiment of FIGS. 10a and 10b. Seams 22 can also include pores or other openings 22p for ingress of fluids into the seam to accelerate biodegradation as is shown in the embodiment of FIG. 10. Other means for accelerating biodegradation of seams 22 can include pre-stressing the seam and/or including perforations 22f in the seam as is also shown in the embodiment of FIG. 10. In still other embodiments, seam 22 can be constructed of materials and/or have a structure which is readily degraded by absorption of ultrasound energy, e.g. high frequency ultrasound (HIFU), allowing the capsule to be degraded into smaller pieces using externally or endoscopically (or other minimally invasive method) administered ultrasound.

[0080] Suitable materials for seams 22 can include one or more biodegradable materials described herein such as PLGA, glycolic acid etc. Seams 22 can be attached to capsule body 20 using various joining methods known in the polymer arts such as molding, hot melt junctions, etc. Additionally for embodiments of capsule 20 which are also fabricated from biodegradable materials, faster biodegradation of seam 22 can be achieved by one or more of the following: i) fabricating the seam from a faster biodegrading material, ii) pre-stressing the seam, or iii) perforating the seam. The concept of using biodegradable seams 22 to produce controlled degradation of a swallowable device in the GI tract can also be applied to other swallowable devices such as swallowable cameras (or other swallowable imaging device) to facilitate passage through the GI tract and reduce the likelihood of such a device becoming stuck in the GI tract. Accordingly, embodiments of biodegradable seam 22 can be adapted for swallowable imaging and other swallowable devices.

[0081] Another aspect of the invention provides methods for the delivery of drugs and other therapeutic agents (in the form of medication 100) into the walls of the GI tract using one or more embodiments of swallowable drug delivery device 10. An exemplary embodiment of such a method will now be described. The described embodiment of drug delivery occurs in the small intestine SI. However, it should be appreciated that this is exemplary and that embodiments of the invention can be used for delivering drug in a number of locations in the GI tract including the stomach and the large intestine. For ease of discussion, the swallowable drug delivery device 10 will sometimes be referred to herein as a capsule. As described above, in various embodiments device 10 may be packaged as a kit 11 within sealed packaging 12

that includes device **10** and a set of instructions for use **15**. If the patient is using a handheld device **13**, the patient may be instructed to enter data into device **13** either manually or via a bar code **18** (or other identifying indicia **18**) located on the instructions **15** or packaging **12**. If a bar code is used, the patient would scan the bar code using a bar code reader **19** on device **13**. After opening packaging **12**, reading the instructions **15** and entering any required data, the patient swallows an embodiment of the swallowable drug delivery device **10**. Depending upon the drug, the patient may take the device **10** in conjunction with a meal (before, during or after) or a physiological measurement. Capsule **20** is sized to pass through the GI tract and travels through the patient's stomach S and into the small intestine SI through peristaltic action as is embodied in device **10** is shown in the embodiment of FIG. **11**. Once in the small intestine, the release element **70** is degraded by the basic pH in the small intestine (or other chemical or physical condition unique to the small intestine) so as to actuate the actuating mechanism **60** and deliver medication **100** into the wall of the small intestine SI according to one or more embodiments of the invention. For embodiments including a hollow needle or other hollow tissue penetrating member **40**, medication delivery is effectuated by using the actuating mechanism **60** to advance the needle **40** a selected distance into the mucosa of the intestinal wall IS, and then the medication is injected through the needle lumen **40** by advancement of the delivery member **50**. The delivery member **50** is withdrawn and the needle **40** is then withdrawn back within the body of the capsule (e.g. by recoil of the spring) detaching from the intestinal wall. For embodiments of device **10** having multiple needles, a second or third needle **42**, **43** can also be used to deliver additional doses of the same drug or separate drugs **101**. Needle advancement can be done substantially simultaneously or in sequence. In preferred embodiments that use multiple needles, needle advancement can be done substantially simultaneously so as to anchor device **10** in the small intestine during drug delivery.

[0082] After medication delivery, device **10** then passes through the intestinal tract including the large intestine LI and is ultimately excreted. For embodiments of the capsule **20** having biodegradable seams **22** or other biodegradable portions, the capsule is degraded in the intestinal tract into smaller pieces to facilitate passage through and excretion from the intestinal tract as is shown in the embodiments of FIGS. **9a** and **9b**. In particular embodiments having biodegradable tissue penetrating needles/members **40**, should the needle get stuck in the intestinal wall, the needle biodegrades releasing the capsule **20** from the wall.

[0083] For embodiments of device **10** including a sensor **67**, actuation of mechanism **60** can be effectuated by the sensor sending a signal to actuating mechanism **60** and/or a processor **29**/controller **29c** coupled to the actuating mechanism. For embodiments of device **10** including external actuation capability, the user may externally activate actuating mechanism **60** at a selected time period after swallowing the capsule. The time period can be correlated to a typical transit time or range of transit times for food moving through the user's GI tract to a particular location in the tract such as the small intestine.

[0084] One or more embodiments of the above methods can be used for the delivery of preparations **100** containing therapeutically effective amounts of a variety of drugs and other therapeutic agents **101** to treat a variety of diseases and

conditions. These include a number of large molecule peptides and proteins which would otherwise require injection due to chemical breakdown in the stomach. The dosage of the particular drug can be titrated for the patient's weight, age or other parameter. Also the dose of drug **101** to achieve a desired or therapeutic effect (e.g., insulin for blood glucose regulation) when delivered by one or more embodiments of the invention can be less than the amount required should the drug have been delivered by conventional oral delivery (e.g., a swallowable pill that is digested in the stomach and absorbed through the wall of the small intestine). This is due to the fact that there is no degradation of the drug by acid and other digestive fluids in the stomach and the fact that all, as opposed to only a portion of the drug is delivered into the wall of the small intestine (or other lumen in the intestinal tract, e.g., large intestine, stomach, etc.). Depending upon the drug **101**, the dose **102** delivered in preparation **100** can be in the range from 100 to 5% of a dose delivered by conventional oral delivery (e.g., a pill) to achieve a desired therapeutic effect (e.g., blood glucose regulation, seizure regulation, etc.) with even lower amounts contemplated. The particular dose reduction can be titrated based upon the particular drug, the condition to be treated, and the patient's weight, age and condition. For some drugs (with known levels of degradation in the intestinal tract) a standard dose reduction can be employed (e.g., 10 to 20%). Larger amounts of dose reduction can be used for drugs which are more prone to degradation and poor absorption. In this way, the potential toxicity and other side effects (e.g., gastric cramping, irritable bowel, hemorrhage, etc.) of a particular drug or drugs delivered by device **10** can be reduced because the ingested dose is lowered. This in turn, improves patient compliance because the patient has reduction both in the severity and incidence of side effects. Additional benefits of embodiments employing dose reduction of drug **101** include a reduced likelihood for the patient to develop a tolerance to the drug (requiring higher doses) and, in the case of antibiotics, for the patient to develop resistant strains of bacteria. Also, other levels of dose reduction can be achieved for patients undergoing gastric bypass operations and other procedures in which sections of the small intestine have been removed or its working (e.g., digestive) length effectively shortened.

[0085] In addition to delivery of a single drug, embodiments of swallowable drug delivery device **10** and methods of their use can be used to deliver a plurality of drugs for the treatment of multiple conditions or for the treatment of a particular condition (e.g., protease inhibitors for treatment HIV AIDS). In use, such embodiments allow a patient to forgo the necessity of having to take multiple medications for a particular condition or conditions. Also, they provide a means for facilitating that a regimen of two or more drugs is delivered and absorbed into the small intestine and thus, the blood stream, at about the same time. Due to difference in chemical makeup, molecular weight, etc., drugs can be absorbed through the intestinal wall at different rates, resulting in different pharmacokinetic distribution curves. Embodiments of the invention address this issue by injecting the desired drug mixtures at substantially the same time. This in turn, improves the pharmacokinetics and thus the efficacy of the selected mixture of drugs. Additionally, eliminating the need to take multiple drugs is particularly

beneficial to patients who have one or more long term chronic conditions including those who have impaired cognitive or physical abilities.

[0086] In various applications, embodiments of the above methods can be used to deliver preparations **100** including drugs and therapeutic agents **101** to provide treatment for a number of medical conditions and diseases. The medical conditions and diseases which can be treated with embodiments of the invention can include without limitation: cancer, hormonal conditions (e.g., hypo/hyper thyroid, growth hormone conditions), osteoporosis, high blood pressure, elevated cholesterol and triglyceride, diabetes and other glucose regulation disorders, infection (local or septicemia), epilepsy and other seizure disorders, osteoporosis, coronary arrhythmia's (both atrial and ventricular), coronary ischemia anemia or other like condition. Still other conditions and diseases are also contemplated.

[0087] In many embodiments, the treatment of the particular disease or condition can be performed without the need for injecting the drug or other therapeutic agent (or other non-oral form of delivery such as suppositories) but instead, relying solely on the therapeutic agent(s) that is delivered into the wall of the small intestine or other portion of the GI tract. Similarly, the patient need not take conventional oral forms of a drug or other therapeutic agent, but again rely solely on delivery into the wall of the small intestine using embodiments of the swallowable capsule. In other embodiments, the therapeutic agent(s) delivered into the wall of the small intestine can be delivered in conjunction with an injected dose of the agent(s). For example, the patient may take a daily dose of therapeutic agent using the embodiments of the swallowable capsule, but only need take an injected dose every several days or when the patient's condition requires it (e.g., hyperglycemia). The same is true for therapeutic agents that are traditionally delivered in oral form (e.g., the patient can take the swallowable capsule and take the conventional oral form of the agent as needed). The dosages delivered in such embodiments (e.g., the swallowed and injected dose) can be titrated as needed (e.g., using standard dose response curve and other pharmacokinetic methods can be used to determine the appropriate dosages). Also, for embodiments using therapeutic agents that can be delivered by conventional oral means, the dose delivered using embodiments of the swallowable capsule can be titrated below the dosage normally given for oral delivery of the agent since there is little or no degradation of the agent within the stomach or other portion of the intestinal tract (herein again standard dose response curve and other pharmacokinetic methods can be applied).

[0088] Various groups of embodiments of preparation **100** containing one or more drugs or other therapeutic agents **101** for the treatment of various diseases and conditions will now be described with references to dosages. It should be appreciated that these embodiments, including the particular therapeutic agents and the respective dosages are exemplary and the preparation **100** can comprise a number of other therapeutic agents described herein (as well as those known in the art) that are configured for delivery into a luminal wall in the intestinal tract (e.g., the small intestinal wall) using various embodiments of device **10**. The dosages can be larger or smaller than those described and can be adjusted using one or more methods described herein or known in the art.

[0089] In a group of embodiments, therapeutic agent preparation **100** can comprise a therapeutically effective dose of growth hormone for the treatment of one or more growth disorders, as well as wound healing. In one embodiment, preparation **100** can contain a therapeutically effective amount of growth hormone in the range of about 0.1-4 mg, with particular ranges of 0.1-1, 1-4, 1-2, and 2-4 mg, with still larger ranges contemplated. The particular dose can be titrated based on one or more of the following factors: i) the particular condition to be treated and its severity (e.g. stunted growth, vs. wound healing); ii) the patient's weight; iii) the patient's age; and iv) the frequency of dosage (e.g. daily vs. twice daily).

[0090] Drug delivery compositions and components of known drug delivery systems may be employed and/or modified for use in some embodiments of the inventions described herein. For example, micro-needles and other microstructures used for delivery of drugs through the skin surface with drug patches may be modified and included within the capsules described herein and used to instead deliver a drug preparation into a lumen wall of the gastrointestinal tract such as the wall of the small intestine. Suitable polymer micro-needle structures may be commercially available from Corium of California, such as the MicroCor™ micro delivery system technology. Other components of the MicroCor™ patch delivery systems, including drug formulations or components, may also be incorporated into the capsules described herein. Alternatively, a variety of providers are commercially available to formulate combinations of polymers or other drug-delivery matrices with selected drugs and other drug preparation components so as to produce desired shapes (such as the releasable tissue-penetrating shapes described herein) having desirable drug release characteristics. Such providers may, for example, include Corium, SurModics of Minnesota, Bio-Sensors International of Singapore, or the like.

[0091] One advantage and feature of various embodiments of the therapeutic compositions described herein is that the biologic (therapeutic peptide or protein) drug payload is protected from degradation and hydrolysis by the action of peptidases and proteases in the gastrointestinal (GI) tract. These enzymes are ubiquitous throughout living systems. The GI tract is especially rich in proteases whose function is to break down the complex proteins and peptides in one's diet into smaller segments and release amino acids which are then absorbed from the intestine. The compositions described herein are designed to protect the therapeutic peptide or protein from the actions of these GI proteases and to deliver the peptide or protein payload directly into the wall of the intestine. There are two features in various embodiments of the compositions described herein which serve to protect the protein or peptide payload from the actions of GI proteases. First, in certain embodiments, the capsule shell, which contains the deployment engine and machinery, does not dissolve until it reaches the duodenal and sub-duodenal intestinal segments, owing to the pH-sensitive coating on the outer surface of the capsule which prevents its dissolution in the low pH of the stomach. Second, in certain embodiments, hollow maltose (or other appropriate polymer) micro-spears contain the actual therapeutic peptide or protein; the maltose (or other polymer) micro-spears are designed to penetrate the intestine muscle as soon as the outer capsule shell dissolves; and the micro-spears themselves slowly dissolve in the intestinal muscle

wall to release the drug payload. Thus, the peptide or protein payload is not exposed to the actions of the GI proteases and therefore does not undergo degradation via proteolysis in the GI tract. This feature, in turn, contributes to the high % bioavailability of the therapeutic peptide or protein.

[0092] As discussed above, embodiments described herein include therapeutic compositions comprising a therapeutic agent comprising growth hormone for the treatment of growth hormone deficiency or related disorders. Such compositions result in the delivery of a growth hormone with desirable pharmacokinetic properties. In this regard, pharmacokinetic metrics of note include C_{max} , the peak plasma concentration of a drug after administration; t_{max} , the time to reach C_{max} ; and $t_{1/2}$, the time required for the plasma concentration of the drug to reach half its C_{max} value after having reached C_{max} . These metrics can be measured using standard pharmacokinetic measurement techniques known in the art. In one approach plasma samples may be taken at set time intervals (e.g., one minute, five minutes, 1/2 hour, 1 hour, etc.) beginning and then after administration of the drug or other therapeutic agent either by use of a swallowable device or by non-vascular injection. The concentration of the drug in plasma can then be measured using one or more appropriate analytical methods such as GC-Mass Spec, LC-Mass Spec, HPLC or various ELISA (Enzyme-linked immunosorbent assays) which can be adapted for the particular drug. A concentration vs. time curve (also herein referred to as a concentration profile) can then be developed using the measurements from the plasma samples. The peak of the concentration curve corresponds to C_{max} and the time at which this occurs corresponds to t_{max} . The time in the curve where the concentration reaches half its maximum value (i.e., C_{max}) after having reached C_{max} corresponds to $t_{1/2}$ this value is also known as the elimination half-life of the drug. The start time for determination of C_{max} can be based on the time at which the injection is made for the case on non-vascular injection and the point in time at which embodiments of the swallowable device advances one or more tissue penetrating members (containing the drug) into the small intestine or other location in the GI tract (e.g., the large intestine). In the later case, this time can be determined using one or means including a remote controlled embodiment of the swallowable device which deploys the tissue penetrating members into the intestine wall in response to an external control signal (e.g., an RF signal) or for an embodiment of the swallowable device which sends an RF or other signal detectable outside the body when the tissue penetrating members have been deployed. Other means for detection of tissue penetrating member deployment into the small intestine are contemplated such as one more medical imaging modalities including for example, ultrasound or fluoroscopy. In any one of these studies, appropriate animal models can be used for example, dog, pig, rat etc. in order to model the human pharmacokinetic response.

[0093] Thus, various embodiments provide a therapeutic composition (also referred to herein as a preparation) comprising growth hormone. The composition is adapted for insertion into an intestinal wall after oral ingestion, wherein upon insertion, the composition releases growth hormone into the bloodstream from the intestinal wall to achieve a C_{max} faster than an extravascularly injected dose of the growth hormone that is to say, achieving a C_{max} for the inserted form of growth hormone in a shorter time period (e.g., a smaller t_{max}) than that for a dose of the growth

hormone that is injected extravascularly Note, that the dose of growth hormone in the composition delivered into the intestinal wall and the dose delivered by extravascular injection, may, but need not, be comparable to achieve these results. In various embodiments, the composition is configured to achieve a t_{max} for the growth hormone (e.g., by release of the growth hormone into the bloodstream from the intestinal wall, e.g., that of the small intestine) which is about 80%, or 50%, or 30%, or 20%, or 10% of a t_{max} for an extravascularly injected dose of the growth hormone. Such an extravascularly injected dose of the growth hormone can be, for example, a subcutaneous injection or an intramuscular injection. In certain embodiments, the C_{max} attained by delivering the growth hormone by insertion into the intestinal wall is substantially greater, such as 5, 10, 20, 30, 40, 50, 60, 70, 80 or even a 100 times greater, than the C_{max} attained when the growth hormone is delivered orally without insertion into the intestinal wall for example by a pill other convention oral form of the growth hormone or related compound. In some embodiments, the growth hormone composition is configured to produce a long-term release of the growth hormone. Also, the composition can be configured to produce a long-term release of the growth hormone with a selectable $t_{1/2}$. For example, the selectable $t_{1/2}$ may be 6, or 9, or 12, or 15 or 18, or 24 hours. Any type of acceptable growth hormone may be used, including somatotropin (recombinant human growth hormone). Suitable conditions for treatment with growth hormone include treatment of children with short stature or growth failure associated with growth hormone deficiency, Turner syndrome, idiopathic short stature, SHOX deficiency, failure to catch up in height after small for gestational age birth, and treatment of adults with either childhood-onset or adult-onset growth hormone deficiency.

[0094] Various embodiments also provide a therapeutic composition comprising growth hormone adapted for insertion into an intestinal wall after oral ingestion, wherein upon insertion, the composition releases growth hormone into the blood stream from the intestinal wall to achieve a $t_{1/2}$ that is greater than a $t_{1/2}$ for an orally ingested dose of the growth hormone that is not inserted into the intestinal wall. For example, the $t_{1/2}$ of the dose inserted into the intestinal wall may be 100 or 50 or 10 or 5 times greater than the dose that is not inserted into the intestinal wall.

[0095] The therapeutic composition may comprising growth hormone may be in solid form, such as a solid form composition configured to degrade in the intestinal wall, and the solid form composition may have, for example, a tissue penetrating feature such as a pointed tip. The therapeutic growth hormone composition may comprise at least one biodegradable material and/or may comprise at least one pharmaceutical excipient, including a biodegradable polymer such as PGLA or a sugar such as maltose.

[0096] The therapeutic composition, comprising growth hormone may be adapted to be orally delivered in a swallowable capsule. In certain embodiments such a swallowable capsule may be adapted to be operably coupled to a mechanism having a first configuration and a second configuration, the therapeutic composition being contained within the capsule in the first configuration and advanced out of the capsule and into the intestinal wall in the second configuration. Such an operably coupled mechanism may comprise at least one of an expandable member, an expandable balloon, a valve, a tissue penetrating member, a valve

coupled to an expandable balloon, or a tissue penetrating member coupled to an expandable balloon.

[0097] In some embodiments, the therapeutic composition, comprising growth hormone, may be configured to be delivered within a lumen of a tissue penetrating member and/or the therapeutic composition may be shaped as a tissue penetrating member advanceable into the intestinal wall. The tissue penetrating member may be sized to be completely contained within the intestinal wall, and/or it may include a tissue penetrating feature for penetrating the intestinal wall, and/or it may include a retaining feature for retaining the tissue penetrating member within the intestinal wall. The retaining feature may comprise, for example, a barb. In some embodiments, the tissue penetrating member is configured to be advanced into the intestinal wall by the application of a force to a surface of the tissue penetrating member and, optionally, the tissue penetrating member has sufficient stiffness to be advanced completely into the intestinal wall and/or the surface of the penetrating member is configured to be operatively coupled to an expandable balloon which applies the force upon expansion and/or the tissue penetrating member is configured to detach from a structure applying the force when a direction of the force changes.

[0098] Various aspects of the invention also provide other embodiments of a swallowable delivery device for the delivery of medication 100 in addition to those described above. According to one or more such embodiments, the swallow delivery device can include one or more expandable balloons or other expandable devices for use in delivering one or more tissue penetrating members including medication 100 into the wall of an intestine, such as the small intestine. Referring now to FIGS. 12-20, another embodiment of a device 110 for the delivery of medication 100 to a delivery site DS in the gastro-intestinal (GI) tract, can comprise a capsule 120 sized to be swallowed and pass through the intestinal tract, a deployment member 130, one or more tissue penetrating members 140 containing medication 100, a deployable aligner 160 and a delivery mechanism 170. In some embodiments, medication 100 (also referred to herein as preparation 100) may itself comprise tissue penetrating member 140. The deployable aligner 160 is positioned within the capsule and configured to align the capsule with the intestine such as the small intestine. Typically, this will entail aligning a longitudinal axis of the capsule with a longitudinal axis of the intestine; however, other alignments are also contemplated. The delivery mechanism 170 is configured for delivering medication 100 into the intestinal wall and will typically include a delivery member 172 such as an expandable member. The deployment member 130 is configured for deploying at least one of the aligner 160 or the delivery mechanism 170. As will be described further herein, all or a portion of the capsule wall is degradable by contact with liquids in the GI tract so as to allow those liquids to trigger the delivery of medication 100 by device 110. As used herein, "GI tract" refers to the esophagus, stomach, small intestine, large intestine and anus, while "Intestinal tract" refers to the small and large intestine. Various embodiments of the invention can be configured and arranged for delivery of medication 100 into both the intestinal tract as well as the entire GI tract.

[0099] Device 110 including tissue penetrating member 140 can be configured for the delivery of liquid, semi-liquid or solid forms of medication 100 or combinations of all

three. Whatever the form, medication 100 desirably has a material consistency allowing the medication to be advanced out of device 110, into the intestinal wall (small or large intestine) or other luminal wall in the GI tract and then degrade within the intestinal wall to release the drug or other therapeutic agent 101. The material consistency of medication 100 can include one or more of the hardness, porosity and solubility of the preparation (in body fluids). The material consistency can be achieved by selection and use of one or more of the following: i) the compaction force used to make the preparation; ii) the use of one or more pharmaceutical disintegrants known in the art; iii) use of other pharmaceutical excipients; iv) the particle size and distribution of the preparation (e.g., micronized particles); and v) use of micronizing and other particle formation methods known in the art.

[0100] Capsule 120 is sized to be swallowed and pass through the intestinal tract. The size can also be adjusted depending upon the amount of drug to be delivered as well as the patient's weight and adult vs. pediatric applications. Typically, the capsule will have a tubular shape with curved ends similar to a vitamin. In these and related embodiments, capsule lengths 120L can be in the range of 0.5 to 2 inches and diameters 120D in the range of 0.1 to 0.5 inches with other dimensions contemplated. The capsule 120 includes a capsule wall 121w, having an exterior surface 125 and an interior surface 124 defining an interior space or volume 124v. In some embodiments, the capsule wall 121w can include one or more apertures 126 sized for the outward advancement of tissue penetrating members 140. In addition to the other components of device 110, (e.g., the expandable member etc.) the interior volume can include one or more compartments or reservoirs 127.

[0101] The capsule can be fabricated from various biodegradable gelatin materials known in the pharmaceutical arts, but can also include various enteric coatings 120c, configured to protect the cap from degradation in the stomach (due to acids etc.), and then subsequently degrade in the in higher pH's found in the small intestine or other area of the intestinal tract. In various embodiments, the capsule 120 can be formed from multiple portions one or more of which may be biodegradable. In many embodiments, capsule 120 can be formed from two portions 120p such as a body portion 120p" (herein body 120p") and a cap portion 120p' (herein cap 120p), where the cap fits onto the body, e.g., by sliding over or under the body (with other arrangements also contemplated). One portion such as the cap 120p' can include a first coating 120c' configured to degrade above a first pH (e.g., pH 5.5) and the second portion such as the body 120p" can include a second coating 120c" configured to degrade above a second higher pH (e.g. 6.5). Both the interior 124 and exterior 125 surfaces of capsule 120 are coated with coatings 120c' and 120c" so that that either portion of the capsule will be substantially preserved until it contacts fluid having the selected pH. For the case of body 120p" this allows the structural integrity of the body 120p" to be maintained so as to keep balloon 172 inside the body portion and not deployed until balloon 130 has expanded. Coatings 120c' and 120c" can include various methacrylate and ethyl acrylate based coatings such as those manufactured by Evonik Industries under the trade name EUDRAGIT. These and other dual coating configurations of the capsule 120 allows for mechanisms in one portion of capsule 120 to be actuated before those in the other portion

of the capsule. This is due to the fact that intestinal fluids will first enter those portions where the lower pH coating has degraded thus actuating triggers which are responsive to such fluids (e.g., degradable valves). In use, such dual coating embodiments for capsule **120** provide for targeted drug delivery to a particular location in the small intestine (or other location in the GI tract), as well as improved reliability in the delivery process. This is due to the fact that deployment of a particular component, such as aligner **160**, can be configured to begin in the upper area of the small intestine (e.g., the duodenum) allowing the capsule to be aligned within the intestine for optimal delivery of the drug (e.g., into the intestinal wall) as well as providing sufficient time for deployment/actuation of other components to achieve drug delivery into the intestinal wall while the capsule is still in the small intestine or other selected location.

[0102] As is discussed above, one or more portions of capsule **120** can be fabricated from various biocompatible polymers known in the art, including various biodegradable polymers which in a preferred embodiment can comprise cellulose, gelatin materials PLGA (polylactic-co-glycolic acid). Other suitable biodegradable materials include various enteric materials described herein as well as lactide, glycolide, lactic acid, glycolic acid, para-dioxanone, caprolactone, trimethylene carbonate, caprolactone, blends and copolymers thereof.

[0103] In various embodiments, the wall **120_w** of the capsule is degradable by contact with liquids in the GI tract for example liquids in the small intestine. In preferred embodiments, the capsule wall is configured to remain intact during passage through the stomach, but then to be degraded in the small intestine. In one or more embodiments, this can be achieved by the use of an outer coating or layer **120_c** on the capsule wall **120_w**, which only degrades in the higher pH's found in the small intestine and serves to protect the underlying capsule wall from degradation within the stomach before the capsule reaches the small intestine (at which point the drug delivery process is initiated by degradation of the coating as is described herein). In use, such coatings allow for the targeted delivery of a therapeutic agent in a selected portion of the intestinal tract such as the small intestine.

[0104] Similar to capsule **20**, in various embodiments, capsule **120** can include various radio-opaque, echogenic or other materials for location of the device using one or more medical imaging modalities such as fluoroscopy, ultrasound, MRI, etc.

[0105] As is discussed further herein, in many embodiments, one or more of the deployment member **130**, delivery member **172** or deployable aligner **160**, may correspond to an expandable balloon that is shaped and sized to fit within capsule **120**. Accordingly, for ease of discussion, deployment member **130**, delivery member **172** and deployable aligner **160** will now be referred to as balloon **130**, **160** and **172**; however, it should be appreciated that other devices including various expandable devices are also contemplated for these elements and may include for example, various shape memory devices (e.g., an expandable basket made from shape memory biodegradable polymer spires), expandable piezo electric devices, and/or chemically expandable devices having an expanded shape and size corresponding to the interior volume **124_v** of the capsule **120**.

[0106] One or more of balloons **130**, **160** and **172** can comprise various polymers known in the medical device arts. In preferred embodiments such polymers can comprise one or more types of polyethylene (PE) which may correspond to low density PE (LDPE), linear low density PE (LLDPE), medium density PE (MDPE) and high density PE (HDPE) and other forms of polyethylene known in the art. In one more embodiments using polyethylene, the material may be cross-linked using polymer irradiation methods known in the art so. In particular embodiments radiation-based cross-linking may be used as to control the inflated diameter and shape of the balloon by decreasing the compliance of the balloon material. The amount of radiation may be selected to achieve a particular amount of cross linking to in turn produce a particular amount of compliance for a given balloon, e.g., increased irradiation can be used to produce stiffer less compliant balloon material. Other suitable polymers can include PET (polyethylene terephthalate), silicone and polyurethane. In various embodiments balloons **130**, **160** and **172** may also include various radio-opaque materials known in the art such as barium sulfate to allow the physician to ascertain the position and physical state of the balloon (e.g., un-inflated, inflated or punctured). Balloons **130**, **160** and **172** can be fabricated using various balloon blowing methods known in the balloon catheters arts (e.g., mold blowing, free blowing, etc.) to have a shape and size which corresponds approximately to the interior volume **124_v** of capsule **120**. In various embodiments one or more of balloons **130**, **160** and **172** and various connecting features (e.g., connecting tubes) can have a unitary construction being formed from a single mold. Embodiments employing such unitary construction provide the benefit of improved manufacturability and reliability since fewer joints must be made between one or more components of device **110**.

[0107] Suitable shapes for balloons **130**, **160** and **172** include various cylindrical shapes having tapered or curved end portions (an example of such a shape including a hot dog). In some embodiments, the inflated size (e.g., diameter) of one or more of balloons **130**, **160** and **172**, can be larger than capsule **120** so as to cause the capsule to come apart from the force of inflation, (e.g., due to hoop stress). In other related embodiments, the inflated size of one or more of balloons **130**, **160** and **172** can be such that when inflated: i) the capsule **120** has sufficient contact with the walls of the small intestine so as to elicit a peristaltic contraction causing contraction of the small intestine around the capsule, and/or ii) the folds of the small intestine are effaced to allow. Both of these results allow for improved contact between the capsule/balloon surface and the intestinal wall so as deliver tissue penetrating members **40** over a selected area of the capsule and/or delivery balloon **172**. Desirably, the walls of balloons **130**, **160** and **172** will be thin and can have a wall thickness in the range of 0.005 to 0.0001" more preferably, in the range of 0.005 to 0.0001, with specific embodiments of 0.004, 0.003, 0.002, 0.001, and 0.0005). Additionally in various embodiments, one or more of balloon **130**, **160** or **172** can have a nested balloon configuration having an inflation chamber **1601C** and extended finger **160EF** as is shown in the embodiments of FIG. **13c**. The connecting tubing **163**, connecting the inflation chamber **1601C** can be narrow to only allow the passage of gas **168**, while the connecting tubing **36** coupling the two halves of balloon **130** can be larger to allow the passage of water.

[0108] As indicated above, the aligner 160 will typically comprise an expandable balloon and for ease of discussion, will now be referred to as aligner balloon 160 or balloon 160. Balloon 160 can be fabricated using materials and methods described above. It has an unexpanded and expanded state (also referred to as a deployed state). In its expanded or deployed state, balloon 160 extends the length of capsule 120 such that forces exerted by the peristaltic contractions of the small intestine SI on capsule 120 serve to align the longitudinal axis 120LA of the capsule 120 in a parallel fashion with the longitudinal axis LAI of the small intestine SI. This in turn serves to align the shafts of tissue penetrating members 140 in a perpendicular fashion with the surface of the intestinal wall IW to enhance and optimize the penetration of tissue penetrating members 140 into the intestinal wall IW. In addition to serving to align capsule 120 in the small intestine, aligner 160 is also configured to push delivery mechanism 170 out of capsule 120 prior to inflation of delivery balloon 172 so that the delivery balloon and/or mechanism is not encumbered by the capsule. In use, this push out function of aligner 160 improves the reliability for delivery of the therapeutic agent since it is not necessary to wait for particular portions of the capsule (e.g., those overlying the delivery mechanism) to be degraded before drug delivery can occur.

[0109] Balloon 160 may be fluidically coupled to one or more components of device 110 including balloons 130 and 172 by means of polymer tube or other fluidic couplings 162 which may include a tube 163 for coupling balloons 160 and 130 and a tube 164 for coupling balloon 160 and balloon 172. Tube 163 is configured to allow balloon 160 to be expanded/inflated by pressure from balloon 130 (e.g., pressure generated the mixture of chemical reactants within balloon 130) and/or otherwise allow the passage of liquid between balloons 130 and 160 to initiate a gas generating chemical reaction for inflation of one or both of balloons 130 and 160. Tube 164 connects balloon 160 to 172 so as to allow for the inflation of balloon 172 by balloon 160. In many embodiments, tube 164 includes or is coupled to a control valve 155 which is configured to open at a selected pressure so as to control the inflation of balloon 172 by balloon 160. Tube 164 may thus comprise a proximal portion 164p connecting to the valve and a distal portion 164d leading from the valve. Typically, proximal and distal portions 164p and 164d will be connected to a valve housing 158 as is described below.

[0110] Valve 155 may comprise a triangular or other shaped section 156 of a material 157 which is placed within a chamber 158c of a valve housing 158 (alternately, it may be placed directly within tubing 164). Section 157 is configured to mechanically degrade (e.g., tears, shears, delaminates, etc.) at a selected pressure so as to allow the passage of gas through tube 164 and/or valve chamber 158c. Suitable materials 157 for valve 155 can include bees wax or other form of wax and various adhesives known in the medical arts which have a selectable sealing force/burst pressure. Valve fitting 158 will typically comprise a thin cylindrical compartment (made from biodegradable materials) in which section 156 of material 157 is placed (as is shown in the embodiment of FIG. 13b) so as to seal the walls of chamber 158c together or otherwise obstruct passage of fluid through the chamber. The release pressure of valve 155 can be controlled through selection of one or more of the size and shape of section 156 as well as the selection of

material 157 (e.g., for properties such as adhesive strength, shear strength etc.). In use, control valve 155 allows for a sequenced inflation of balloon 160 and 172 such that balloon 160 is fully or otherwise substantially inflated before balloon 172 is inflated. This, in turn, allows balloon 160 to push balloon 172 along with the rest of delivery mechanism 170 out of capsule 120 (typically from body portion 120p') before balloon 172 inflates so that deployment of tissue penetrating members 140 is not obstructed by capsule 120. In use, such an approach improves the reliability of the penetration of tissue penetrating members 140 into intestinal wall IW both in terms of achieving a desired penetration depth and delivering greater numbers of the penetrating members 140 contained in capsule 120 since the advancement of the members into intestinal wall IW is not obstructed by capsule wall 120w.

[0111] As is describe above, the inflated length 160I of the aligner balloon 160 is sufficient to have the capsule 120 become aligned with the lateral axis of the small intestine from peristaltic contractions of the intestine. Suitable inflated lengths 160I for aligner 160 can include a range between about 1/2 to two times the length 120I of the capsule 120 before inflation of aligner 160. Suitable shapes for aligner balloon 160 can include various elongated shapes such as a hotdog like shape. In specific embodiments, balloon 160 can include a first section 160' and a second section 160'', where expansion of first section 160' is configured to advance delivery mechanism 170 out of capsule 120 (typically out of and second section 160'' is used to inflate delivery balloon 172. In these and related embodiments, first and second sections 160' and 160'' can be configured to have a telescope-style inflation where first section 160' inflates first to push mechanism 170 out of the capsule (typically from body portion 120p') and second section 160'' inflates to inflate delivery member 172. This can be achieve by configuring first section 160' to have smaller diameter and volume than second section 160'' such that first section 160' inflates first (because of its smaller volume) and with second section 160'' not inflating until first section 60' has substantially inflated. In one embodiment, this can be facilitated by use of a control valve 155 (described above) connecting sections 160' and 160'' which does not allow passage of gas into section 160'' until a minimum pressure has been reached in section 160'. In some embodiments, the aligner balloon can contain the chemical reactants which react upon mixture with water or other liquid from the deploying balloon.

[0112] In many embodiments, the deployment member 130 will comprise an expandable balloon, known as the deployment balloon 130. In various embodiments, deployment balloon 30 is configured to facilitate deployment/expansion of aligner balloon 160 by use of a gas, for example, generation of a gas 169 from a chemical. The gas may be generated by the reaction of solid chemical reactants 165, such as an acid 166 (e.g., citric acid) and a base 166 (e.g., potassium bicarbonate, sodium bicarbonate and the like) which are then mixed with water or other aqueous liquid 168. The amount of reactants can be chosen using stoichiometric methods to produce a selected pressure in one or more of balloons 130, 160 and 72. The reactants 165 and liquids can be stored separately in balloon 130 and 160 and then brought together in response to a trigger event, such as the pH conditions in the small intestine. The reactants 165 and liquids 168 can be stored in either balloon, however in

preferred embodiments, liquid **168** is stored in balloon **130** and reactants **165** in balloon **160**. To allow for passage of the liquid **168** to start the reaction and/or the resulting gas **169**, balloon **130** may be coupled to aligner balloon **160** by means of a connector tube **163** which also typically includes a separation means **150** such as a degradable valve **150** described below. For embodiments where balloon **130** contains the liquid, tube **163** has sufficient diameter to allow for the passage of sufficient water from balloon **130** to balloon **60** to produce the desired amount of gas to inflate balloon **160** as well inflate balloon **172**. Also when balloon **130** contains the liquid, one or both of balloon **30** and tube **63** are configured to allow for the passage of liquid to balloon **160** by one or more of the following: i) the compressive force applied to balloon **130** by peristaltic contractions of the small intestine on the exposed balloon **130**; and ii) wicking of liquid through tube **163** by capillary action.

[0113] Tube **163** will typically include a degradable separation valve or other separation means **150** which separates the contents of balloon **130**, (e.g., water **158**) from those of balloon **160** (e.g., reactants **165**) until the valve degrades. Valve **150** can be fabricated from a material such as maltose, which is degradable by liquid water so that the valve opens upon exposure to water along with the various liquids in the digestive tract. It may also be made from materials that are degradable responsive to the higher pH's found in the intestinal fluids such as methacrylate based coatings. The valve is desirably positioned at location on tube **163** which protrudes above balloon **130** and/or is otherwise sufficient exposed such that when cap **120p'** degrades the valve **150** is exposed to the intestinal liquids which enter the capsule. In various embodiments, valve **150** can be positioned to lie on the surface of balloon **130** or even protrude above it (as is shown in the embodiments of FIGS. **16a** and **16b**), so that it has clear exposure to intestinal fluids once cap **120p'** degrades. Various embodiments of the invention provide a number of structures for a separation valve **150**, for example, a beam like structure (where the valve comprises a beam that presses down on tube **163** and/or connecting section **136**), or collar type structure (where the valve comprise a collar lying over tube **163** and/or connecting section **136**). Still other valve structures are also contemplated.

[0114] Balloon **130** has a deployed and a non-deployed state. In the deployed state, the deployment balloon **130** can have a dome shape **130d** which corresponds to the shape of an end of the capsule. Other shapes **130s** for the deployed balloon **130** are also contemplated, such as spherical, tube-shape, etc. The reactants **165** will typically include at least two reactants **166** and **167**, for example, an acid such as citric acid and a base such as sodium bicarbonate. Other reactants **165** including other acids, e.g., ascorbic acid and bases, e.g., sodium hydroxide are also contemplated. When the valve or other separation means **150** opens, the reactants mix in the liquid and produce a gas such as carbon dioxide which expands the aligner balloon **160** or other expandable member.

[0115] In an alternative embodiment shown in FIG. **13b**, the deployment balloon **130** can actually comprise a first and second balloon **130'** and **130''** connected by a tube **36** or other connection means **136** (e.g., a connecting section). Connecting tube **136** will typically include a separation valve **150** that is degradable by a liquid as described above and/or a liquid having a particular pH such as basic pH

found in the small intestine (e.g., 5.5 or 6.5). The two balloons **130'** and **130''** can each have a half dome shape **130hs** allowing them to fit into the end portion of the capsule when in the expanded state. One balloon can contain the chemical reactant(s) **165** (e.g., sodium bicarbonate, citric acid, etc.) the other the liquid water **168**, so that when the valve is degraded the two components mix to form a gas which inflates one or both balloons **130'** and **130''** and in turn, the aligner balloon **160**.

[0116] In yet another alternative embodiment, balloon **130** can comprise a multi-compartment balloon **130mc**, that is formed or other constructed to have multiple compartments **130c**. Typically, compartments **130c** will include at least a first and a second compartment **134** and **135** which are separated by a separation valve **150** or other separation means **150** as is shown in the embodiment of FIG. **14a**. In many embodiments, compartments **134** and **135** will have at least a small connecting section **136** between them which is where separation valve **150** will typically be placed. A liquid **168**, typically water, can be disposed within first compartment **134** and one or more reactants **165** disposed in second compartment **135** (which typically are solid though liquid may also be used) as is shown in the embodiment of FIG. **14a**. When valve **150** opens (e.g., from degradation caused by fluids within the small intestine) liquid **168** enters compartment **135** (or vice versa or both), the reactant(s) **165** mix with the liquid and produce a gas **169** such as carbon dioxide which expands balloon **130** which in turn can be used to expand one or more of balloons **160** and **172**.

[0117] Reactants **165** will typically include at least a first and a second reactant, **166** and **167** for example, an acid such as citric acid and a base such as sodium bi-carbonate or potassium bi-carbonate. As discussed herein, in various embodiments they may be placed in one or more of balloon **130** (including compartments **134** and **135** or halves **130'** and **130''**) and balloon **160**. Additional reactants, including other combinations of acids and bases which produce an inert gas by product are also contemplated. For embodiments using citric acid and sodium or potassium bicarbonate, the ratios between the two reactants (e.g., citric acid to potassium bicarbonate) can be in the range of about 1:1 to about 1:4, with a specific ratio of about 1:3. Desirably, solid reactants **165** have little or no absorbed water. Accordingly, one or more of the reactants, such as sodium bicarbonate or potassium bicarbonate can be pre-dried (e.g., by vacuum drying) before being placed within balloon **130**. Other reactants **165** including other acids, e.g., ascorbic acid and bases are also contemplated. The amounts of particular reactants **165**, including combinations of reactants can be selected to produce particular pressures using known stoichiometric equations for the particular chemical reactions as well as the inflated volume of the balloon and the ideal gas law (e.g., $PV=nRT$). In particular embodiments, the amounts of reactants can be selected to produce a pressure selected one or more of balloons **130**, **160** and **172** to: i) achieve a particular penetration depth into the intestinal wall; and produce a particular diameter for one or more of balloons **130**, **160** and **172**; and iii) exert a selected amount of force against intestinal wall IW. In particular embodiments, the amount and ratios of the reactants (e.g., citric acid and potassium bicarbonate) can be selected to achieve pressures in one more of the balloons **130**, **160** and **172** in the range of 10 to 15 psi, with smaller and larger pressures contem-

plated. Again the amounts and ratios of the reactants to achieve these pressures can be determined using known stoichiometric equations.

[0118] In various embodiments of the invention using chemical reactants 165 to generate gas 169, the chemical reactants alone or in combination with the deployment balloon 130 can comprise a deployment engine for 180 deploying one or both of the aligner balloon 160 and delivery mechanism 170 including delivery balloon 172. Deployment engine 180 may also include embodiments using two deployment balloons 130 and 130" (a dual dome configuration as shown in FIG. 13*b*), or a multi compartment balloon 130*mc* as shown in FIG. 14*a*. Other forms of a deployment engine 180 are also contemplated by various embodiments of the invention such as use of expandable piezo-electric materials (that expand by application of a voltage), springs and other shape memory materials and various thermally expandable materials.

[0119] One or more of the expandable balloons 130, 160 and 172 will also typically include a deflation valve 159 which serves to deflate the balloon after inflation. Deflation valve 159 can comprise biodegradable materials which are configured to degrade upon exposure to the fluids in the small intestine and/or liquid in one of the compartments of the balloon so as to create an opening or channel for escape of gas within a particular balloon. Desirably, deflation valves 159 are configured to degrade at a slower rate than valve 150 to allow sufficient time for inflation of balloons, 130, 160 and 172 before the deflation valve degrades. In various embodiments, of a compartmentalized balloon 130, deflation valve 159 can correspond to a degradable section 139 positioned on an end portion 131 of the balloon as is shown in the embodiment of FIG. 14*a*. In this and related embodiments, when degradable section 139 degrades from exposure to the liquid, balloon wall 132 tears or otherwise comes apart providing for a high assurance of rapid deflation. Multiple degradable sections 139 can be placed at various locations within balloon wall 132.

[0120] In various embodiments of balloon 172, deflation valve 159 can correspond to a tube valve 173 attached to the end 172*e* of the delivery balloon 172 (opposite to the end which is coupled to the aligner balloon) as is shown in the embodiment of FIG. 13*b*. The tube valve 173 comprises a hollow tube 173*t* having a lumen that is obstructed at a selected location 1731 with a material 173*m* such as maltose that degrades upon exposure to fluid such as the fluid in the small intestine. The location 1731 of the obstructing material 173*m* in tube 173*t* is selected to provide sufficient time for the delivery balloon 172 to inflate and deliver the tissue penetrating members 40 into the intestinal wall IW before the obstructing material dissolves to open valve 173. Typically, this will be close to the end 173*e* of the tube 173*t*, but not quite so as to allow time for liquid to have to wick into the tube lumen before it reaches material 173*m*. According to one or more embodiments, once the deflation valve 173 opens, it not only serves to deflate the delivery balloon 172 but also the aligner balloon 160 and deployment balloon 130 since in many embodiments, all three are fluidically connected (aligner balloon being fluidically connected to delivery balloon 172 and the deployment balloon 130 being fluidically connected to aligner balloon 160). Opening of the deflation valve 173 can be facilitated by placing it on the end 172*e* of the delivery balloon 172 that is forced out of capsule 120 by inflation of the aligner balloon 160 so that the

deflation valve has good exposure to liquids in the small intestine. Similar tube deflation valves 173 can also be positioned on one or both of aligner balloon 162 and the deployment balloon 130. In these later two cases, the obstructing material in the tube valve can be configured to degrade over a time period to allow sufficient time for inflation of delivery balloon 172 and advancement of tissue penetrating members 140 into the intestinal wall.

[0121] Additionally, as further backup for insured deflation, one or more puncture elements 182 can be attached to the inside surface 124 of the capsule such that when a balloon (e.g., balloon 130, 160, 172) fully inflates it contacts and is punctured by the puncture element 182. Puncture elements 182 can comprise short protrusions from surface 124 having a pointed tip. In another alternative or additional embodiment of means for balloon deflation, one or more of the tissue penetrating members 140 can be directly coupled to the wall of 172*w* of balloon 172 and configured to tear away from the balloon when they detach, tearing the balloon wall in the process.

[0122] A discussion will now be presented of tissue penetrating members 140. Tissue penetrating member 140 can be fabricated from various drugs and other therapeutic agents 101, one or more pharmaceutical excipients (e.g., disintegrants, stabilizers, etc.) and one or more biodegradable polymers. The later materials chosen to confer desired structural and material properties to the penetrating member (for example, column strength for insertion into the intestinal wall, or porosity and hydrophilicity for control the release of drug). Referring now to FIGS. 18*a*-18*f*, in many embodiments, the penetrating member 140 can be formed to have a shaft 144 and a needle tip 145 or other pointed tip 145 so as to readily penetrate tissue of the intestinal wall as shown in the embodiment of FIG. 18*a*. In preferred embodiments, tip 145 has a trocar shape as is shown in the embodiment of FIG. 18*c*. Tip 145 may comprise various degradable materials (within the body of the tip or as a coating), such as sucrose or other sugar which increase the hardness and tissue penetrating properties of the tip. Once placed in the intestinal wall, the penetrating member 140 is degraded by the interstitial fluids within the wall tissue so that the drug or other therapeutic agent 101 dissolves in those fluids and is absorbed into the blood stream. One or more of the size, shape and chemical composition of tissue penetrating member 140 can be selected to allow for dissolution and absorption of drug 101 in a matter of seconds, minutes or even hours. Rates of dissolution can be controlled through the use of various disintegrants known in the pharmaceutical arts. Examples of disintegrants include, but are not limited to, various starches such as sodium starch glycolate and various cross linked polymers such as carboxymethyl cellulose. The choice of disintegrants can be specifically adjusted for the environment within the wall of the small intestine.

[0123] Tissue penetrating member 140 will also typically include one or more tissue retaining features 143 such as a barb or hook to retain the penetrating member within the tissue of the intestinal wall IW after advancement. Retaining features 143 can be arranged in various patterns 143*p* to enhance tissue retention such as two or more barbs symmetrically or otherwise distributed around and along member shaft 144 as is shown in the embodiments of FIGS. 18*a* and 18*b*. Additionally, in many embodiments, penetrating

member will also include a recess or other mating feature **146** for attachment to a coupling component on delivery mechanism **170**.

[0124] Tissue penetrating member **140** is desirably configured to be detachably coupled to platform **175** (or other component of delivery mechanism **170**), so that after advancement of the tissue penetrating member **140** into the intestinal wall, the penetrating member detaches from the balloon. Detachability can be implemented by a variety of means including: i) the snugness or fit between the opening **174** in platform **175** and the member shaft **144**; ii) the configuration and placement of tissue retaining features **143** on penetrating member **140**; and iii) the depth of penetration of shaft **144** into the intestinal wall. Using one or more of these factors, penetrating member **140** be configured to detach as a result of balloon deflation (where the retaining features **143** hold the penetrating member **140** in tissue as the balloon deflates or otherwise pulls back away from the intestinal wall) and/or the forces exerted on capsule **120** by a peristaltic contraction of the small intestine.

[0125] In a specific embodiment, the detachability and retention of tissue penetrating member **140** in the intestinal wall IW can be enhanced by configuring the tissue penetrating member shaft **144** to have an inverse taper **144t** as is shown in the embodiment of FIG. **18c**. The taper **144t** on the shaft **144** is configured such that the application of peristaltic contractile forces from the intestinal wall on the shaft result in the shaft being forced inward (e.g., squeezed inward). This is due to the conversion by shaft taper **144t** of the laterally applied peristaltic force PF to an orthogonal force OF acting to force the shaft inward into the intestinal wall. In use, such inverse tapered shaft configurations serve to retain tissue penetrating member **140** within the intestinal wall so as to detach from platform **175** (or other component of delivery mechanism **170**) upon deflation of balloon **172**. In additional embodiments, tissue penetrating members **140** having an inverse tapered shaft may also include one or more retaining features **143** to further enhance the retention of the tissue penetrating member within intestinal wall IW once inserted.

[0126] As described above, in various embodiments, tissue penetrating member **140** can be fabricated from a number of drugs and other therapeutic agents **101**. Also according to one or more embodiments, the tissue penetrating member may be fabricated entirely from drug **101** or may have other constituent components as well, e.g., various pharmaceutical excipients (e.g., binders, preservatives, disintegrants, etc.), polymers conferring desired mechanical properties, etc. Further, in various embodiments one or more tissue penetrating members **140** can carry the same or a different drug **101** (or other therapeutic agent) from other tissue penetrating members. The former configuration allows for the delivery of greater amounts of a particular drug **101**, while the later, allows two or more different drugs to be delivered into the intestinal wall at about the same time to facilitate drug treatment regimens requiring substantial concurrent delivery of multiple drugs. In embodiments of device **110**, having multiple delivery assemblies **178** (e.g., two, one on each face of balloon **172**), a first assembly **178'** can carry tissue penetrating members having a first drug **101** and a second assembly **178''** can carry tissue penetrating members having a second drug **101**.

[0127] Typically, the drug or other therapeutic agent **101** carried by the tissue penetrating member **140** will be mixed

in with a biodegradable material **105** to form tissue penetrating member **140**. Material **105** may include one or more biodegradable polymers such as PLGA, cellulose, as well as sugars such as maltose or other biodegradable material described herein or known in the art. In such embodiments, the penetrating member **140** may comprise a substantially heterogeneous mixture of drug **101** and biodegradable material **105**. Alternatively, the tissue penetrating member **140** may include a portion **141** formed substantially from biodegradable material **105** and a separate section **142** that is formed from or contains drug **101** as shown in the embodiment of FIG. **18d**. In one or more embodiments, section **142** may correspond to a pellet, slug, cylinder or other shaped section **142s** of drug **101**. Shaped section **142s** may be pre-formed as a separate section which is then inserted into a cavity **142c** in tissue penetrating member **140** as is shown in the embodiments of FIGS. **18e** and **18f**. Alternatively section **142s** may be formed by adding of drug preparation **100** to cavity **142c**. In embodiments, where drug preparation **100** is added to cavity **142c**, preparation may be added in as a powder, liquid, or gel which is poured or injected into cavity **142c**. Shaped section **142s** may be formed of drug **101** by itself or a drug preparation containing drug **101** and one or more binders, preservatives, disintegrates and other excipients. Suitable binders include polyethylene glycol (PEG) and other binders known in the art. In various embodiments, the PEG or other binder may comprise in the range of about 10 to 90% weight percent of the section **142s**, with a preferred embodiment for insulin preparations of about 25-90 weight percent. Other excipients which may be used for binders may include, PLA, PLGA, cyclodextrin, cellulose, methyl cellulose, maltose, dextrin, sucrose and PGA. Further information on the weight percent of excipients in section **142** may be found in Table 1. For ease of discussion, section **142** is referred to as a pellet in the table, but the data in the table is also applicable to other embodiments of section **142** described herein.

[0128] In various embodiments, the weight of tissue penetrating member **140** can range between about 10 to 15 mg, with larger and smaller weights contemplated. For embodiments of tissue penetrating member **140** fabricated from maltose, the weight can range from about 11 to 14 mg. In various embodiments, depending upon the drug **101** and the desired delivered dose, the weight percent of drug in member **140** can range from about 0.1 to about 15%. In exemplary embodiments, these weight per cents correspond to embodiments of members **140** fabricated from maltose or PLGA, however they are also applicable to any of the biodegradable materials **105** used in the fabrication of members **140**. The weight percent of drug or other therapeutic agent **101** in member **140** can be adjusted depending upon the desired dose as well as to provide for structural and stoichiometric stability of the drug and also to achieve a desired concentration profile of the drug in the blood or other tissue of the body. Various stability tests and models (e.g., using the Arrhenius equation) known in the art and/or known rates of drug chemical degradation may be used to make specific adjustments in the weight percent range. Table 1 lists the dose and weight percent range for insulin and number of other drugs which may be delivered by tissue penetrating member **140**. In some cases, the table lists ranges as well a single value for the dose. It should be appreciated that these values are exemplary and other values recited herein including the claims are also considered.

Further, embodiments of the invention also consider variations around these values including for example, ± 1 , ± 5 , ± 10 , ± 25 , and even larger variations. Such variations are considered to fall within the scope of an embodiment claiming a particular value or range of values. The table also lists the weight percentage of drug in in section 142 for various drugs and other therapeutic agents, where again for ease of discussion, section 142 is referred to as a pellet. Again, embodiments of the invention consider the variations described above.

TABLE 1

Drug	Dose Via Capsule**	% Weight of Drug in the needle	% Weight of drug in pellet
Insulin	4-9 units, 5-30 units, 1-50 Units	2-15%	10-75%
Exenatide	1-10 ug, 1-20 ug, 10 ug	<1%, 0.1-1%	0.2-1%
Liraglutide	0.1-1 mg, 0.5-2 mg, 0.6 mg	3-6%	25-40%
Pramlintide	15-120 ug	0.1-1%	0.5-6%
Growth Hormone	0.2-1 mg, 0.1-4 mg	2-10%	10-50%
Somatostatin and Analogs	50-600 ug, 10-100 ug	0.3-8%	2-35%
GnRH and Analogs	0.3-1.5 mg, 0.1-2 mg	2-15%	15-75%
Vasopressin	2-10 units	<1%, 0.1-1%	0.2-1%
PTH and Analogues	0.1 to 10 ug, 10-30 ug, 20 ug	1-2%	0.5-2%
Interferons and analogs			
1. For Multiple Sclerosis	0.03-0.25 mg	0.1-3%	1.5-15%
2. For Hep B and HepC	6-20 ug	0.05-0.2%	0.2-1%
Adalimumab	1-5 mg, 2-4 mg	8-12%	70-90%
Infliximab	1-10, 5 mg	8-12%	70-90%
Etanercept	1-5 mg, 3 mg	8-12%	70-90%
Natalizumab	1-5 mg, 3 mg	8-12%	70-90%

[0129] Tissue penetrating member 140 can be fabricated using one or more polymer and pharmaceutical fabrication techniques known in the art. For example, drug 101 (with or without biodegradable material 105) can be in solid form and then formed into the shape of the tissue penetrating member 140 using molding, compaction or other like method with one or more binding agents added. Alternatively, drug 101 and/or drug preparation 100 may be in solid or liquid form and then added to the biodegradable material 105 in liquid form with the mixture then formed into the penetrating member 140 using molding or other forming method known in the polymer arts.

[0130] Desirably, embodiments of the tissue penetrating member 140 comprising a drug or other therapeutic agent 101 and degradable material 105 are formed at temperatures which do not produce any substantial thermal degradation of drug including drugs such as various peptides and proteins. This can be achieved through the use of room-temperature curing polymers and room temperature molding and solvent evaporation techniques known in the art. In particular embodiments, the amount of thermally degraded drug or other therapeutic agent within the tissue penetrating member is desirably less than about 10% by weight and more preferably, less than 5% and still more preferably less than 1%. The thermal degradation temperature(s) for a particular drug are either known or can be determined using methods known in the art and then this temperature can be used to select and adjust the particular polymer processing methods

(e.g., molding, curing, solvent evaporation methods etc.) to minimize the temperatures and associated level of drug thermal degradation.

[0131] A description will be provided of delivery mechanism 170. Typically, the mechanism will comprise a delivery assembly 178 (containing tissue penetrating members 140) that is attached to delivery balloon 172 as is shown in the embodiment of FIGS. 16a and 16b. Inflation of the delivery balloon provides a mechanical force for engaging delivery assembly 172 outwards from the capsule and into the intestinal wall IW so as to insert tissue penetrating members 140 into the wall. In various embodiments, the delivery balloon 172 can have an elongated shape with two relatively flat faces 172f connected by an articulated accordion-like body 172b. The flat faces 172f can be configured to press against the intestinal wall (IW) upon expansion of the balloon 172 so as to insert the tissue penetrating members (TPMs) 140 into the intestinal wall. TPMs 140 (either by themselves or as part of a delivery assembly 178 described below) can be positioned on one or both faces 172f of balloon 172 to allow insertion of drug containing TPMs 40 on opposite sides of the intestinal wall. The faces 172f of balloon 172 may have sufficient surface area to allow for placement of a number of drug containing TPMs 140 on each face.

[0132] Referring now to FIG. 19, a description will now be provided of the assembly of delivery assembly 178. In a first step 300, one or more tissue penetrating members 140 can be detachably coupled to a biodegradable advancement structure 175 which may correspond to a support platform 175 (also known as platform 175). In preferred embodiments, platform 175 includes one or more openings 174 for insertion of members 140 as shown in step 300. Openings 174 are sized to allow for insertion and retention of members 140 in platform 175 prior to expansion of balloon 172 while allowing for their detachment from the platform upon their penetration into the intestinal wall. Support platform 175 can then be positioned within a carrying structure 176 as shown in step 301. Carrying structure 176 may correspond to a well structure 176 having side walls 176s and a bottom wall 176b which define a cavity or opening 176c. Platform 175 is desirably attached to inside surface of bottom wall 176b using adhesive or other joining methods known in the art. Well structure 176 can comprise various polymer materials and may be formed using vacuum forming techniques known in the polymer processing arts. In many embodiments, opening 176o can be covered with a protective film 177 as shown in step 302. Protective film 177 has properties selected to function as a barrier to protect tissue penetrating members 140 from humidity and oxidation while still allowing tissue penetrating members 140 to penetrate the film as is described below. Film 177 can comprise various water and/or oxygen impermeable polymers which are desirably configured to be biodegradable in the small intestine and/or to pass inertly through the digestive tract. It may also have a multi-ply construction with particular layers selected for impermeability to a given substance, e.g., oxygen, water vapor etc. In use, embodiments employing protective film 177 serve to increase the shelf life of therapeutic agent 101 in tissue penetrating members 140, and in turn, the shelf life of device 110. Collectively, support platform 175 attached tissue penetrating members 140, well structure 176, and film 177 can comprise a delivery assembly 178. Delivery assemblies 178 having one or more drugs or therapeutic agents 101

contained within tissue penetrating member **40** or other drug delivery means can be pre-manufactured, stored and subsequently used for the manufacture of device **110** at a later date. The shelf life of assembly **178** can be further enhanced by filling cavity **176c** of the sealed assembly **178** with an inert gas such as nitrogen.

[0133] Referring back to FIGS. **16a** and **16b**, assemblies **178** can be positioned on one or both faces **172f** of balloon **172**. In preferred embodiments, assemblies **178** are positioned on both faces **172f** (as shown in FIG. **16a**) so as to provide a substantially equal distribution of force to opposite sides of the intestinal wall IW upon expansion of balloon **172**. The assemblies **178** may be attached to faces **172f** using adhesives or other joining methods known in the polymer arts. Upon expansion of balloon **172**, TPMs **140** penetrate through film **177**, enter the intestinal wall IW and are retained there by retaining elements **143** and/or other retaining features of TPM **140** (e.g., an inverse tapered shaft **144f**) such that they detach from platform **175** upon deflation of balloon **172**.

[0134] In various embodiments, one or more of balloons **130**, **160** and **172** can be packed inside capsule **120** in a folded, furled or other desired configuration to conserve space within the interior volume **124v** of the capsule. Folding can be done using preformed creases or other folding feature or method known in the medical balloon arts. In particular embodiments, balloon **130**, **160** and **172** can be folded in selected orientations to achieve one or more of the following: i) conserve space, ii) produce a desired orientation of a particular inflated balloon; and iii) facilitate a desired sequence of balloon inflations. The embodiments shown in FIGS. **15a-15f** illustrate an embodiment of a method of folding and various folding arrangements. However, it should be appreciated that this folding arrangement and the resulting balloon orientations are exemplary and others may also be used. In this and related embodiments, folding can be done manually, by automated machine or a combination of both. Also in many embodiments, folding can be facilitated by using a single multi-balloon assembly **7** (herein assembly **7**) comprising balloons **130**, **160**, **170**; valve chamber **158** and assorted connecting tubings **162** as is shown in the embodiments of FIGS. **13a** and **13b**. FIG. **13a** shows an embodiment of assembly **7** having a single dome construction for balloon **130**, while FIG. **13b** shows the embodiment of assembly **7** having dual balloon/dome configuration for balloon **130**. Assembly **7** can be fabricated using a thin polymer film which is vacuum-formed into the desired shape using various vacuum forming and other related methods known in the polymer processing arts. Suitable polymer films include polyethylene films having a thickness in the range of about 0.003 to about 0.010", with a specific embodiment of 0.005". In preferred embodiments, the assembly is fabricated to have a unitary construction so as to eliminate the need for joining one or more components of the assembly (e.g., balloons **130,160**, etc.). However, it is also contemplated for assembly **7** to be fabricated from multiple portions (e.g., halves), or components (e.g., balloons) which are then joined using various joining methods known in the polymer/medical device arts.

[0135] Referring now to FIGS. **15a-15f**; **16a-16b** and **17a-17b**, in a first folding step **210**, balloon **160** is folded over onto valve fitting **158** with balloon **172** being flipped over to the opposite side of valve fitting **158** in the process (see FIG. **15a**). Then in step **211**, balloon **172** is folded at a

right angle to the folded combination of balloon **160** and valve **158** (see FIG. **15b**). Then, in step **212** for dual dome embodiments of balloon **130**, the two halves **130'** and **130''** of balloon **130** are folded onto each other, leaving valve **150** exposed (see FIG. **15c**, for single dome embodiments of balloon **130**, is folded over onto itself see FIG. **15e**). A final folding step **213** can be done whereby folded balloon **130** is folded over 180° to the opposite side of valve fitting **158** and balloon **160** to yield a final folded assembly **8** for dual dome configurations shown in the FIG. **15e** and a final folded assembly **8'** for single dome configurations shown in FIGS. **15e** and **15f**. One or more delivery assemblies **178** are then be attached to assembly **8** in step **214** (typically two the faces **72f** of balloon **72**) to yield a final assembly **9** (shown in the embodiments of FIGS. **16a** and **16b**) which is then inserted into capsule **120**. After an insertion step **215**, the final assembled version of device **110** with inserted assembly **9** is shown FIGS. **17a** and **17b**.

[0136] Referring now to FIGS. **20a-20i**, a description will be provided of a method of using device **110** to deliver medication **101** to a site in the GI tract such as the wall of the small or large intestine. It should be appreciated that the steps and there order is exemplary and other steps and orders also contemplated. After device **110** enters the small intestine SI, the cap coating **120c'** is degraded by the basic pH in the upper small intestine causing degradation of cap **120p'** as shown in step **400** in FIG. **20b**. Valve **150** is then exposed to fluids in the small intestine causing the valve to begin degrade as is shown in step **401** in FIG. **20c**. Then, in step **402**, balloon **130** expands (due to generation of gas **169**) as shown in FIG. **20d**. Then, in step **403**, section **160'** of balloon **160** begins to expand to start to push assembly **178** out of the capsule body as shown in FIG. **20e**. Then, in step **404**, sections **160'** and **160''** of balloon **160** become fully inflated to completely push assembly **178** out of the capsule body extending the capsule length **1201** so as to serve to align capsule lateral axis **120AL** with the lateral axis of the small intestine LAI as shown in FIG. **20f**. During this time, valve **155** is beginning to fail from the increased pressure in balloon **60** (due to the fact that the balloon has fully inflated and there is no other place for gas **169** to go). Then, in step **405**, valve **155** has completely opened, inflating balloon **172** which then pushes the now completely exposed assembly **178** (having been pushed completely out of body **120p''**) radially outward into the intestinal wall IW as shown in FIG. **20g**. Then, in step **406**, balloon **172** continues to expand to now advance tissue penetrating members into the intestinal wall IW as shown in FIG. **20h**. Then, in step **407**, balloon **172**, (along with balloons **160** and **130**) has deflated pulling back and leaving tissue penetrating members retained in the intestinal wall IW. Also, the body portion **120p''** of the capsule has completely degraded (due to degradation of coating **120c''**) along with other biodegradable portions of device **110**. Any portion not degraded is carried distally through the small intestine by peristaltic contraction from digestion and is ultimately excreted.

[0137] The foregoing description of various embodiments of the invention has been presented for purposes of illustration and description. It is not intended to limit the invention to the precise forms disclosed. Many modifications, variations and refinements will be apparent to practitioners skilled in the art. For example, embodiments of the device can be sized and otherwise adapted for various pediatric and neonatal applications as well as various vet-

erinary applications. Also those skilled in the art will recognize, or be able to ascertain using no more than routine experimentation, numerous equivalents to the specific devices and methods described herein. Such equivalents are considered to be within the scope of the present invention and are covered by the appended claims below.

[0138] Elements, characteristics, or acts from one embodiment can be readily recombined or substituted with one or more elements, characteristics or acts from other embodiments to form numerous additional embodiments within the scope of the invention. Moreover, elements that are shown or described as being combined with other elements, can, in various embodiments, exist as standalone elements. Hence, the scope of the present invention is not limited to the specifics of the described embodiments, but is instead limited solely by the appended claims.

1. (canceled)

2. A swallowable device for delivering growth hormone into a gastro-intestinal (GI) lumen wall of a patient, the device comprising:

a swallowable enclosure having an interior;
 a delivery means disposed in the interior; and
 a growth hormone preparation coupled to the delivery means, the growth hormone preparation being supplied in the swallowable enclosure in a shaped form and comprising a therapeutically effective dose of growth hormone;

wherein the delivery means is configured to advance the growth hormone preparation out of the interior away from the delivery means and into the GI lumen wall to release the therapeutically effective dose of growth hormone into the patient's blood stream.

3. The device of claim 2, wherein the GI lumen is the small intestine.

4. The device of claim 2 wherein the GI lumen is the stomach.

5. The device of claim 2, wherein the delivery means is configured to advance the growth hormone preparation out of the interior in response to a condition in the GI lumen.

6. The device of claim 5, wherein the condition is a selected pH.

7. The device of claim 6, wherein the pH is above about 7.1.

8. The device of claim 2, wherein a percentage by weight of growth hormone in the growth hormone preparation is between about 2% to about 10%.

9. The device of claim 2, wherein the therapeutically effective dose of growth hormone is in a range from about 0.1 mg to about 4 mg.

10. The device of claim 9, wherein the therapeutically effective dose of growth hormone is in a range from about 0.2 mg to about 1 mg.

11. The device of claim 2, wherein the growth hormone is somatotropin.

12. The device of claim 2, wherein the growth hormone preparation further comprises at least one pharmaceutical excipient.

13. The device of claim 12, wherein the at least one pharmaceutical excipient comprises at least one of a binder, a preservative, or a disintegrant.

14. The device of claim 2, wherein the growth hormone preparation further comprises a feature for retaining the growth hormone preparation within the GI lumen wall.

15. The device of claim 2, further comprising a tissue penetrating member, wherein the tissue penetrating member comprises the growth hormone preparation, and wherein the delivery means is configured to apply a force to a surface of the tissue penetrating member to advance the growth hormone preparation into the GI lumen wall.

16. The device of claim 15, wherein the tissue penetrating member is formed from the growth hormone preparation.

17. The device of claim 15, wherein the tissue penetrating member further comprises a lumen, and wherein the growth hormone preparation is disposed in the lumen.

18. The device of claim 2, wherein the delivery means comprises an expandable balloon.

19. The device of claim 2, wherein the delivery means comprises a spring.

20. A swallowable device for delivering growth hormone into a gastro-intestinal (GI) lumen wall of a patient, the device comprising:

a swallowable capsule having an interior;
 a delivery mechanism disposed in the interior; and
 a growth hormone preparation operably coupled to the delivery mechanism, the growth hormone preparation being supplied in the swallowable capsule in a solid form and comprising a therapeutically effective dose of growth hormone;

wherein the delivery mechanism has a first configuration and a second configuration, the growth hormone preparation being contained within the capsule in the first configuration and advanced out of the capsule and into the GI lumen wall in the second configuration to release the therapeutically effective dose of growth hormone into the patient's blood stream.

21. The device of claim 20, wherein the delivery mechanism comprises at least one of an expandable member, an expandable balloon, a valve, a tissue penetrating member, a valve coupled to an expandable balloon, or a tissue penetrating member coupled to an expandable balloon.

* * * * *