



US00D513268S

(12) **United States Design Patent**  
**Wang et al.**

(10) **Patent No.:** **US D513,268 S**

(45) **Date of Patent:** **\*\* Dec. 27, 2005**

(54) **TRACTOR**

(75) Inventors: **Jinfu Wang**, Weifang (CN); **Zhi Chi**,  
Weifang (CN); **Jinguang Zhu**, Weifang  
(CN); **Minge Chen**, Weifang (CN);  
**Jinhua Wang**, Weifang (CN);  
**Wenzhong Liu**, Weifang (CN); **Yuanfu**  
**Wang**, Weifang (CN); **Zhengyu Li**,  
Weifang (CN)

(73) Assignee: **Shandong Foton Heavy Industries**  
**Co., Ltd.** (CN)

(\*\*) Term: **14 Years**

(21) Appl. No.: **29/220,206**

(22) Filed: **Dec. 28, 2004**

(51) **LOC (6) Cl.** ..... **12-09**

(52) **U.S. Cl.** ..... **D15/23**

(58) **Field of Search** ..... D15/10, 22-26,  
D15/28, 33; 180/69.2, 78, 90, 89.1, 89.12,  
900; 56/16.7, 20.2, 320.1, 320.2, 255, 13.3,  
13.4

(56) **References Cited**

U.S. PATENT DOCUMENTS

D261,141 S \* 10/1981 Takahashi et al. .... D15/23

D282,849 S \* 3/1986 Funabashi ..... D15/23  
D283,135 S \* 3/1986 Funabashi et al. .... D15/23  
D489,381 S \* 5/2004 Mistry et al. .... D15/23

\* cited by examiner

*Primary Examiner*—Stella Reid

*Assistant Examiner*—Mark A. Goodwin

(74) *Attorney, Agent, or Firm*—Suiter West Swantz pc llc

(57) **CLAIM**

We claim the ornamental design for a tractor, as shown and described.

**DESCRIPTION**

FIG. 1 is a perspective view of a tractor showing our new design;

FIG. 2 is a right side elevation view thereof;

FIG. 3 is a rear elevation view thereof;

FIG. 4 is a left side elevation view thereof;

FIG. 5 is a front elevation view thereof;

FIG. 6 is a top plan view thereof; and,

FIG. 7 is a bottom plan view thereof.

The broken line showing of wheels in FIGS. 1-7 is for illustrative purposes only and forms no part of the claimed design.

**1 Claim, 5 Drawing Sheets**

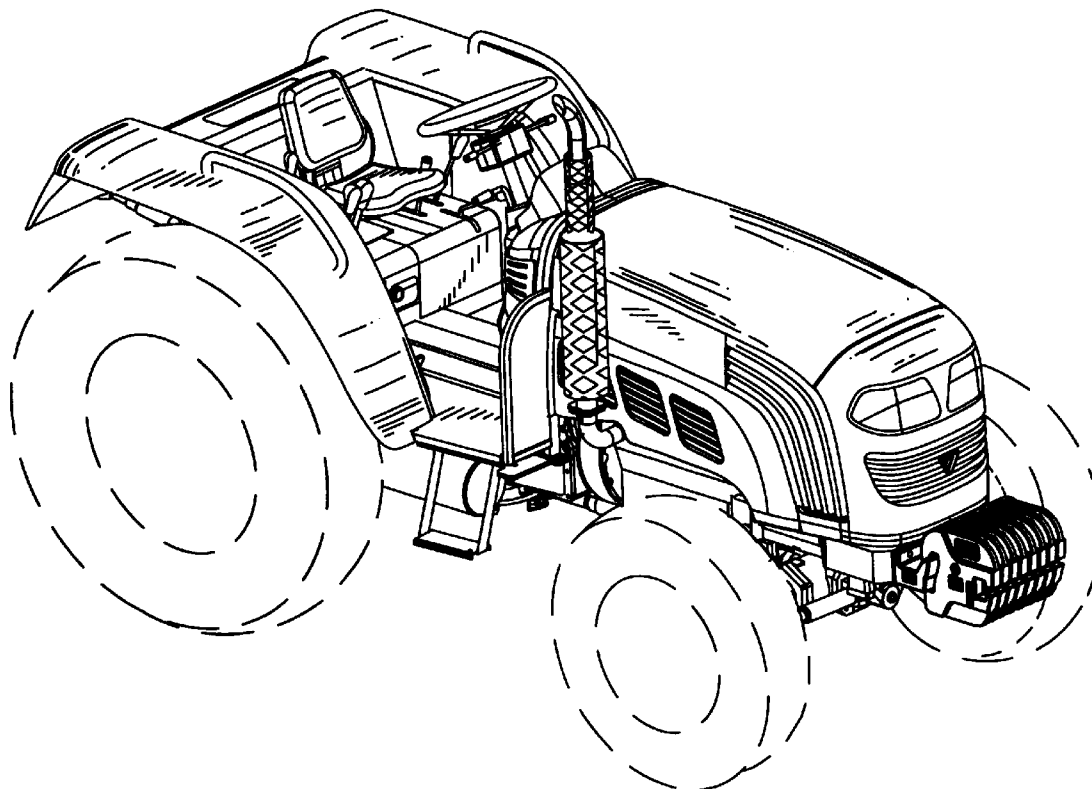

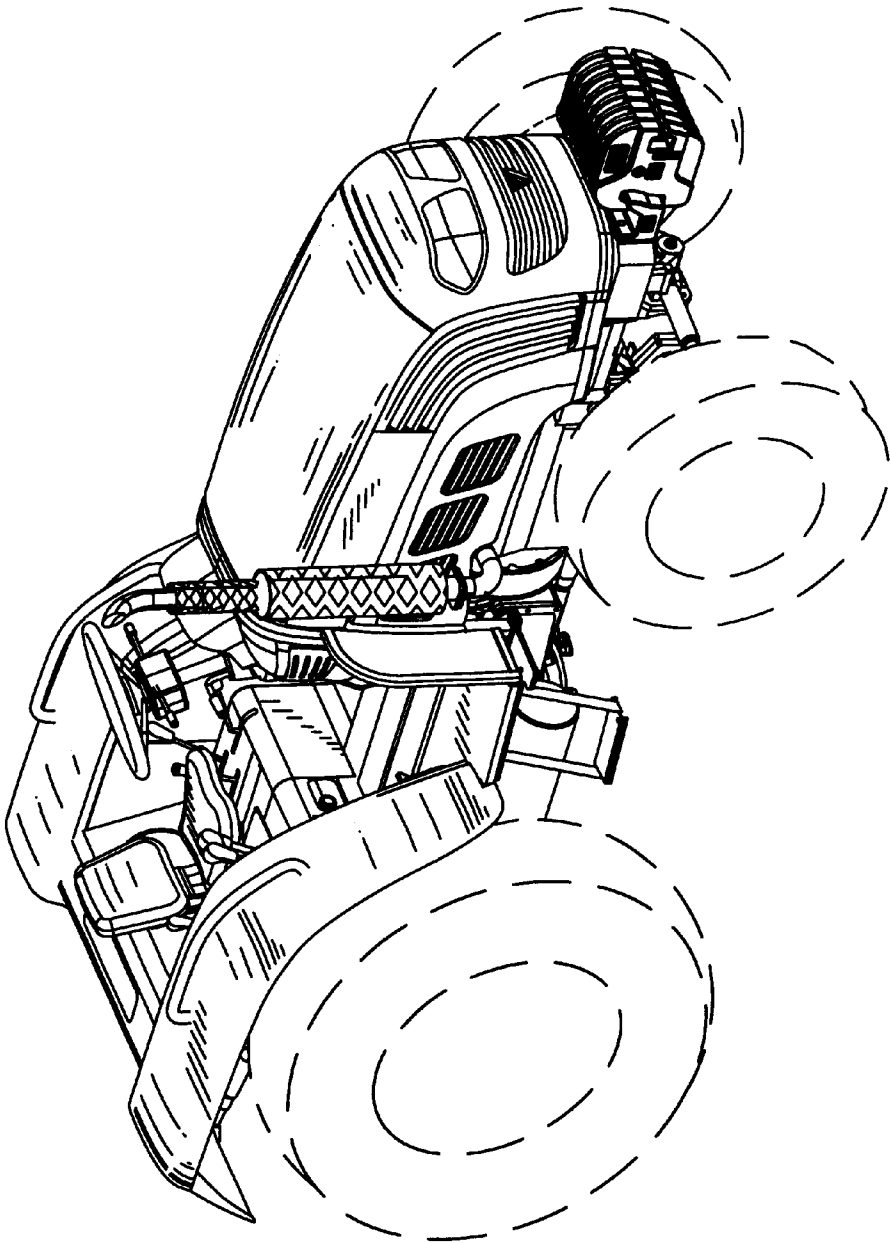

*FIG. 1*

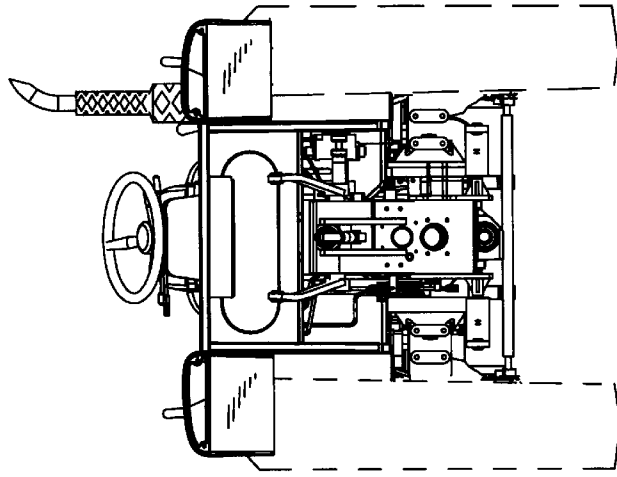

FIG. 3

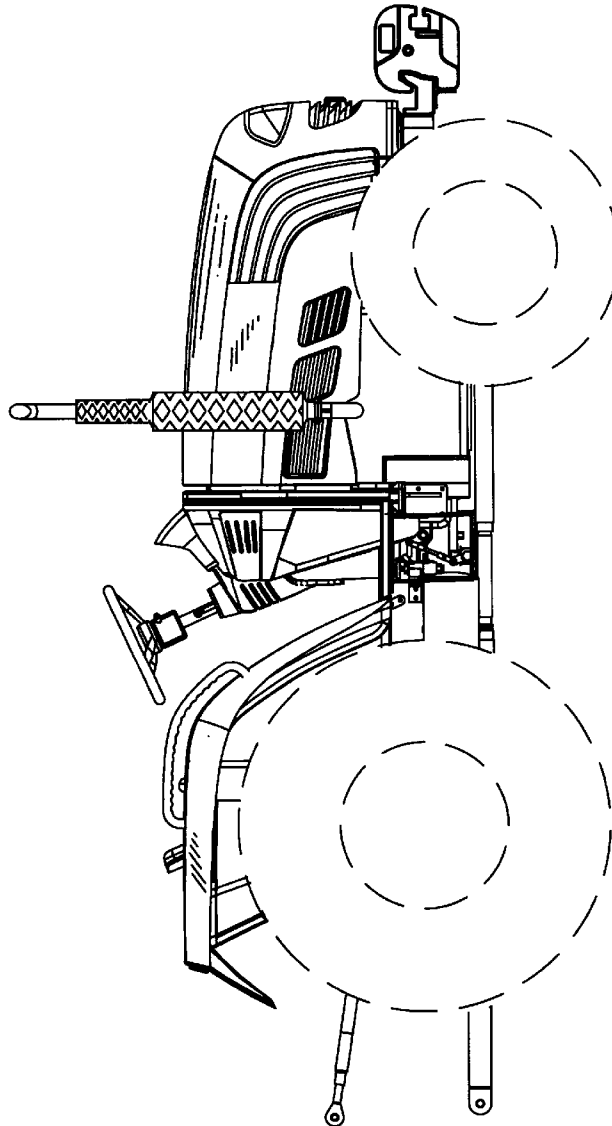

FIG. 2

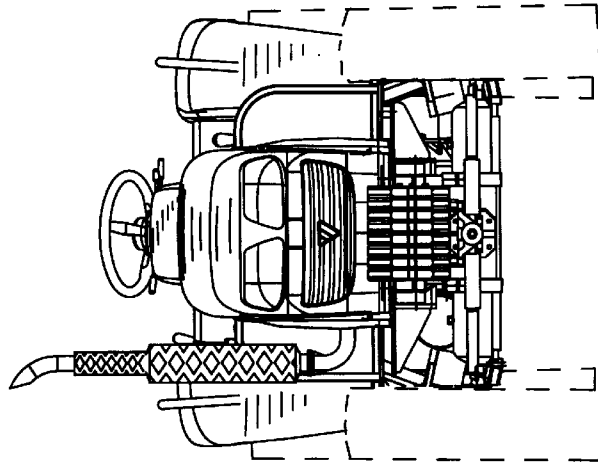

FIG. 5

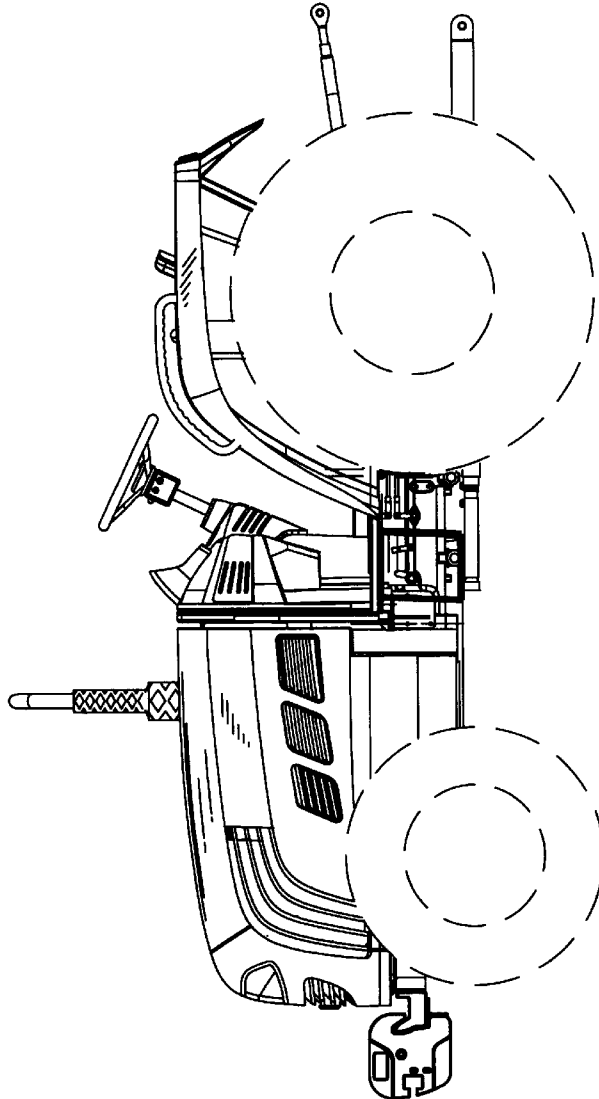
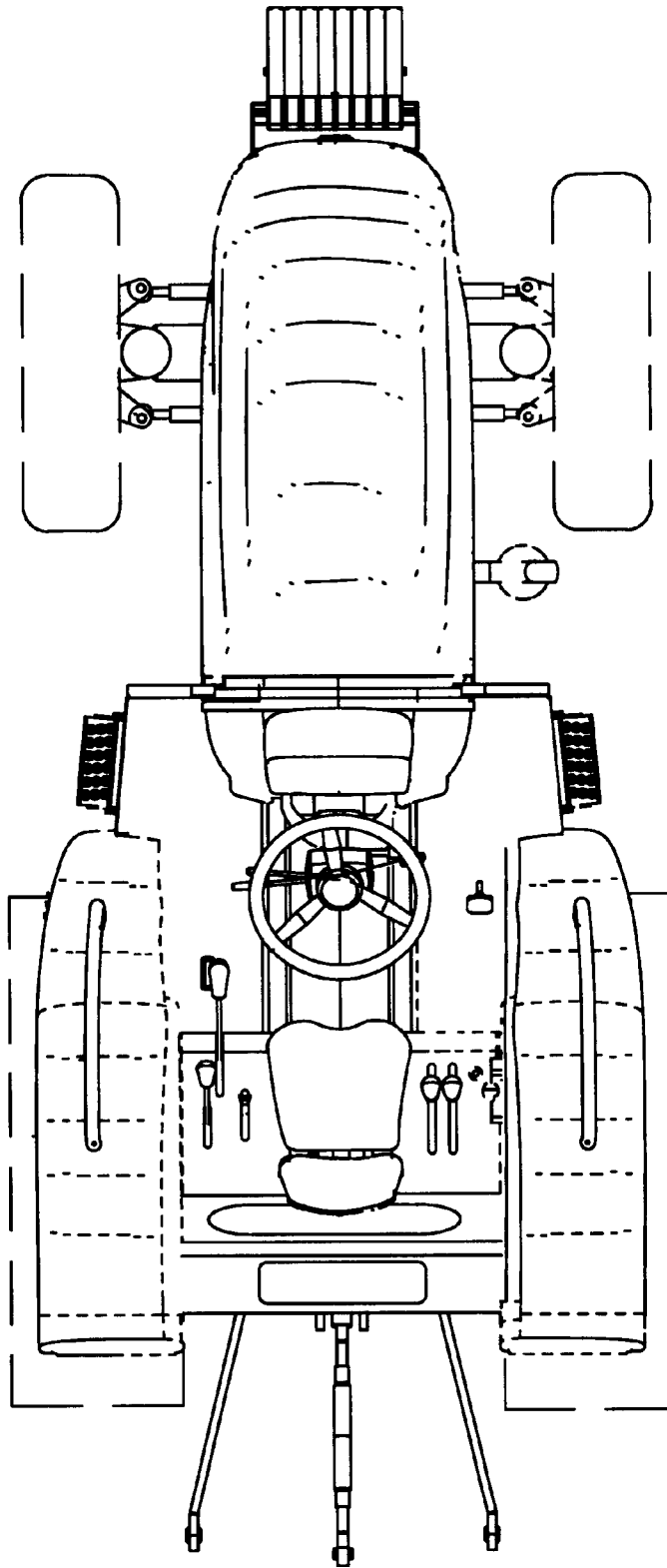

FIG. 4



*FIG. 6*

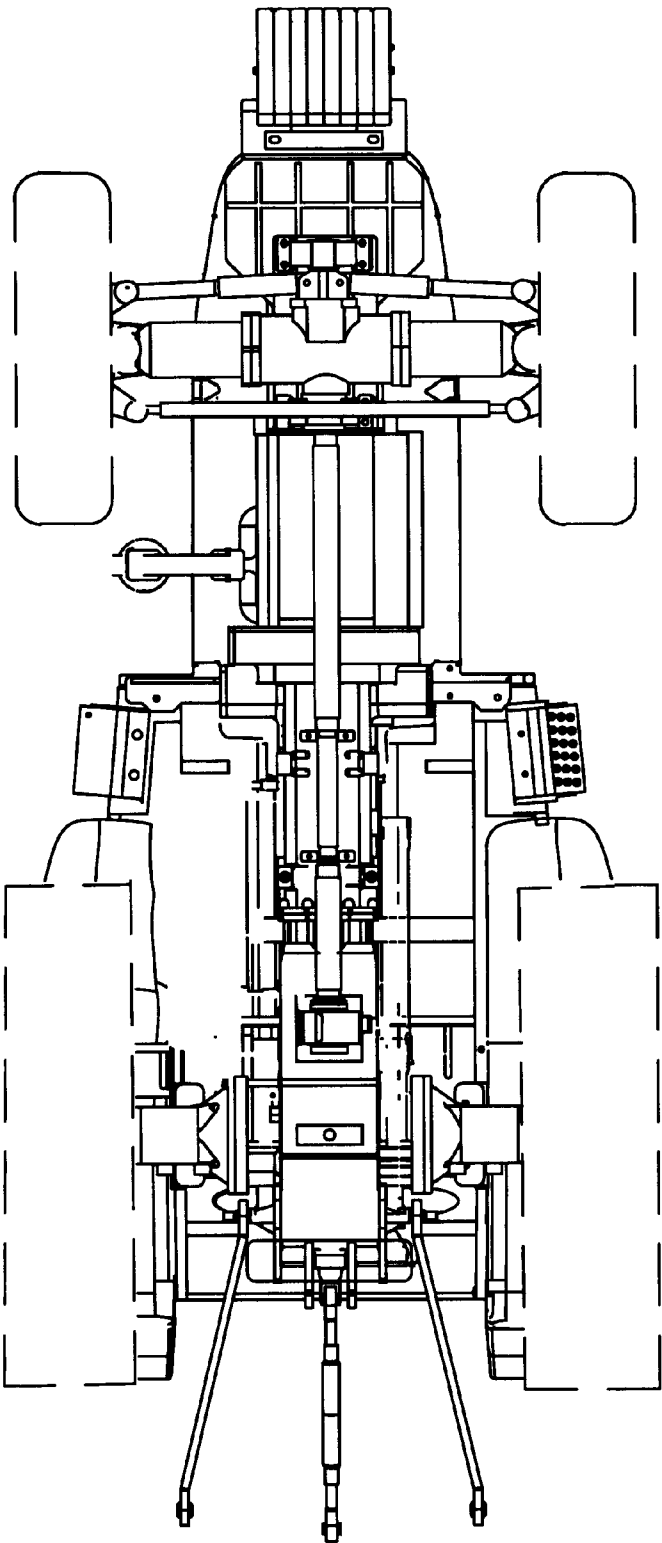

FIG. 7