

No. 847,906.

PATENTED MAR. 19, 1907.

A. M. CLARK.  
HEATER.

APPLICATION FILED MAR. 12, 1906.

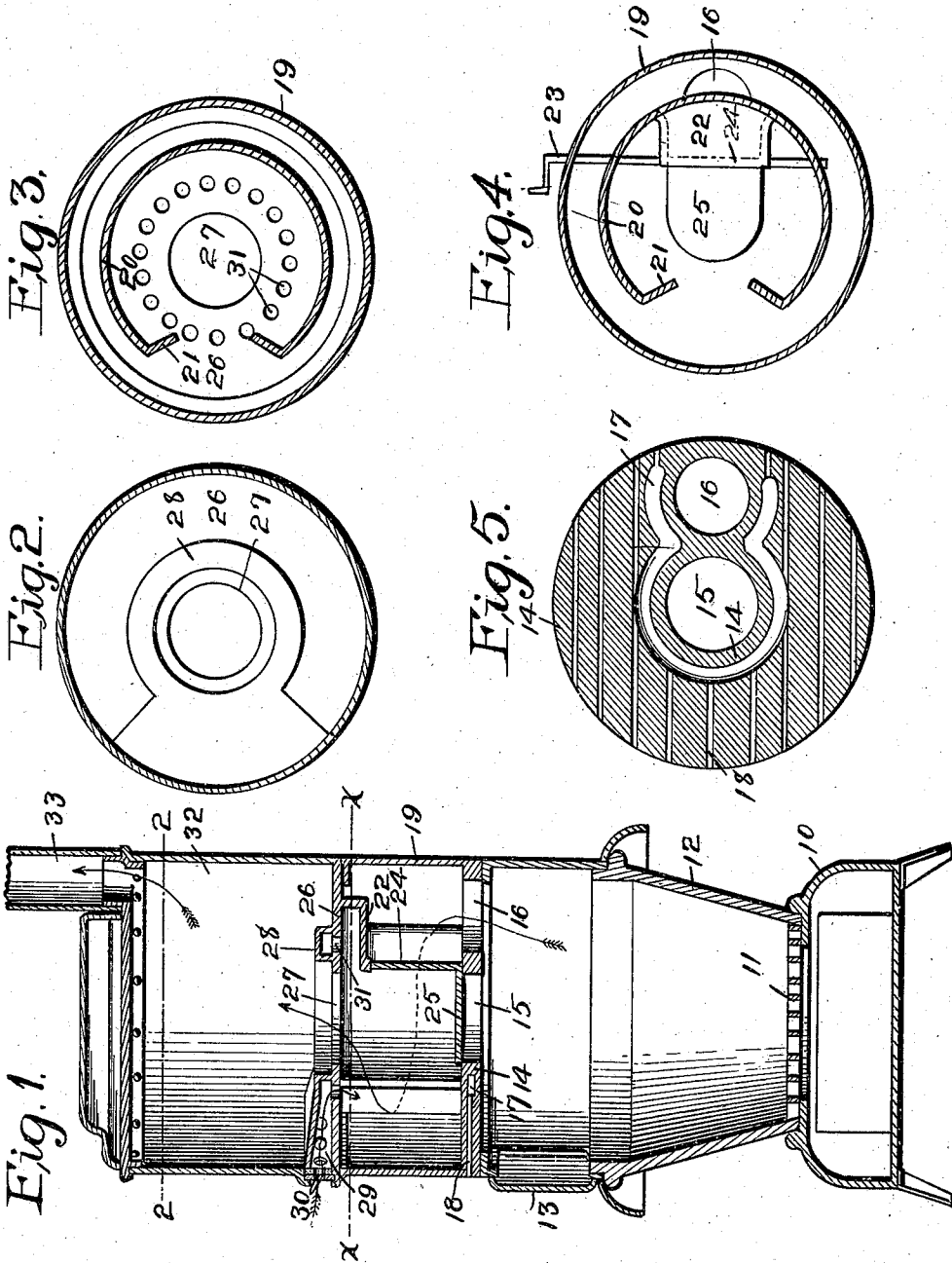

Witnesses  
A. G. Hague  
J. B. Smutney.

Inventor, A. M. Clark  
by Orwig Lane Attys

# UNITED STATES PATENT OFFICE.

ALBERT M. CLARK, OF MARSHALLTOWN, IOWA.

## HEATER.

No. 847,906.

Specification of Letters Patent.

Patented March 19, 1907.

Application filed March 12, 1906. Serial No. 305,601.

*To all whom it may concern:*

Be it known that I, ALBERT M. CLARK, a citizen of the United States, residing at Marshalltown, in the county of Marshall and State of Iowa, have invented a certain new and useful Heater, of which the following is a specification.

The object of my invention is to provide a heater of simple, durable, and inexpensive construction in which the smoke arising from the fuel may be made to pass over a heated metal plate and at the same time fresh air be commingled with the smoke in such quantities as to cause the smoke to ignite and burn and the heat generated by the burning smoke to be utilized for radiating purposes.

A further object is to provide simple and durable means whereby the products of combustion arising from the grate may be made to pass through a direct passage-way to the flue for the purpose of producing a strong draft when desired.

My invention consists in certain details in the construction, arrangement, and combination of the various parts of the device whereby the objects contemplated are attained, as hereinafter more fully set forth, pointed out in my claims, and illustrated in the accompanying drawings, in which—

Figure 1 shows a vertical central sectional view of a heater embodying my invention. Fig. 2 shows a horizontal sectional view on the line 2 2 of Fig. 1. Fig. 3 shows a horizontal sectional view on the line *x x* of Fig. 1 looking upwardly. Fig. 4 shows a view on the same line looking downwardly, and Fig. 5 shows a horizontal sectional view through the smoke-igniting plate.

Referring to the accompanying drawings, I have used the reference-numeral 10 to indicate the lower portion of the heater forming the ash-pit. 11 is a grate therein, and 12 indicates a combustion-chamber having the fuel-door 13 at its front. Extending horizontally across the top of the combustion-chamber is the smoke-igniting plate 14, having a central opening 15 and also an opening 16 at one side thereof. Formed within the plate 14 is a cooling-chamber 17, surrounding the openings 15 and 16 and communicating with the passage-ways 18, which lead to the exterior of the plate. These chambers and passage-ways are designed for the purpose of keeping the plate sufficiently cool so that it will not bend or burn out under any of the

conditions to which it may be subjected. The smoke-burning chamber is indicated by the numeral 19 and is arranged directly over the igniting-plate 14. Within this chamber is a partition 20, spaced apart from the side walls of the chamber and arranged in circular form, with its end edges spaced apart at the front and inclined inwardly at 21 in a direction toward the center of the smoke-burning chamber.

At the rear of the partition 20 I have formed a damper-casing 22, comprising a top and sides. The damper comprises a crank-shaft 23 and two damper-blades 24 and 25, arranged at right angles to each other, and is of such size and shape that when in the position shown in Fig. 1 it will uncover the opening 16 and close the opening 15 and also the passage-way through the damper-casing, so that products of combustion arising from the combustion-chamber must pass through the opening 16, then around the partition 20 and into the chamber on the interior of the partition before it may pass upwardly out of the smoke-burning chamber. If the position of the damper is reversed, the blade 24 will close the opening 16 and the blade 25 will uncover the opening 15 and close the opening through the damper-casing, so that the draft from the combustion-chamber will pass straight upwardly through the opening 15 to the top of the smoke-burning chamber without passing around the outside of the partition 20.

The top of the smoke-burning chamber comprises a horizontal partition 26, formed with a central draft-opening 27. Formed on the top of the partition 26, surrounding the said opening, is a draft-tube 28, communicating at one side with a chamber 29, which extends to the exterior of the furnace. This chamber 29 is provided with a series of draft-openings communicating with the exterior of the heater. The bottom of the draft-tube 28 is provided with perforations 31 to discharge downwardly into the smoke-burning chamber. Above the partition 26 is the radiating-chamber 32 and the flue 33 communicates with it.

In practical use and assuming that the damper is in the position shown in Fig. 1, and assuming, further, that a fire is burning in the combustion-chamber, it is obvious that the plate 14 will be heated, because it is extended across the hottest part of the heater. The smoke and combustible gases arising

from the fire will pass around through the chamber between the partition 20 and the heater-wall, and in so doing they will pass close to the plate 14. At the front of the furnace they enter the chamber inside of the partition 20 and are forced down close to the central portion of the plate 14 and against the blade 25 of the damper by means of the openings 31. By having these currents passing near the heated plate and being commingled with fresh air it is obvious that the smoke and combustible gases will ignite and burn, and, further, if the damper is adjusted to its other position the products of combustion will go in a direct line to the flue, although a certain amount of fresh air will be commingled with them, and they will be burned when the fire is in proper condition.

Having thus described my invention, what I claim, and desire to secure by Letters Patent of the United States therefor, is—

1. In a heater, the combination of a combustion-chamber, a smoke-burning chamber above the combustion-chamber and a radiating-chamber above the smoke-burning chamber, a smoke-igniting plate between the combustion-chamber and the smoke-burning chamber and an upright partition extended around the interior of the smoke-burning chamber, said partition open at one side, the igniting-plate having an opening adjacent to the closed side of the upright partition, the partition above the smoke-burning chamber having an opening above the open side of the upright partition, and means for introducing fresh air into the top of the smoke-burning chamber to supply the necessary oxygen for combustion and to force the smoke downwardly against the igniting-plate.

2. In a heater, a combustion-chamber, a smoke-igniting plate above the combustion-chamber having two openings therein, a partition above said plate forming a passage-way for directing products of combustion arising through one of said openings around the chamber above the plate, a horizontal plate forming a top for the compartment above the partition formed with an opening in line with the other opening of the igniting-plate and means for closing the openings in the igniting-plate.

3. In a heater, a combustion-chamber, a smoke-igniting plate above the combustion-chamber having two openings therein, a partition above said plate forming a passage-way for directing products of combustion arising through one of said openings around the chamber above the plate, a horizontal plate forming a top for the compartment above the partition and formed with an opening in line with the other openings of the igniting-plate, means for closing the openings in the

igniting-plate and means for introducing currents of fresh air into the chamber above the igniting-plate.

4. In a heater, a combustion-chamber, an igniting-plate above it formed with two openings, a chamber above the plate formed with an indirect passage-way communicating with one of said openings and a direct passage-way communicating with the other opening and a damper capable, in one position, of closing the direct passage-way through the igniting-plate and in another position of closing the indirect passage-way

5. In a heater, the combination of a combustion-chamber, a smoke-igniting plate above it formed with two passage-ways, a smoke-burning chamber above the igniting-plate, a circular partition in the smoke-burning chamber spaced apart from the heater-wall and having its edges spaced apart from each other at the front and also having a damper-casing at the rear formed with an opening, a damper formed with two wings in one position covering one of the openings in the igniting-plate and the opening in the damper-casing and in its other position covering the other opening in the plate and also the opening in the damper-casing and a plate at the top of said chamber formed with a direct smoke passage-way communicating with the central portion of the chamber inside of the circular partition.

6. In a heater, the combination of a combustion-chamber, a smoke-igniting plate above it formed with two passage-ways, a smoke-burning chamber above it, a circular partition in the smoke-burning chamber spaced apart from the heater-wall and having its edges spaced apart from each other at the front and also having a damper-casing at the rear formed with an opening, a damper formed with two wings in one position covering one of the openings in the igniting-plate and the opening in the damper-casing and in its other position covering the other opening in the plate and also the opening in the damper-casing and a plate at the top of said chamber formed with a direct smoke passage-way communicating with the central portion of the chamber inside of the circular partition, said upper plate formed with an air-chamber having openings therein communicating with the outside atmosphere and having openings in its bottom to discharge air downwardly into the chamber beneath it.

7. In a heater, a combustion-chamber, smoke-igniting plate at its top formed with a central opening and an opening at its rear, said plate also formed with air-chambers and passage-ways leading from the exterior of the heater into said air-chambers, a circular vertically-arranged partition above the plate with its ends spaced apart at the front and inclined inwardly toward the center of the heater and also formed at its rear with a

damper-casing, a damper formed with two wings, a shaft for operating the damper, said damper in one position closing both the central opening in the igniting-plate and the damper-casing and in its other position closing both the opening at the rear of the igniting-plate and the damper-casing, a horizontal plate above the smoke-igniting burning-chamber having a central opening in line with the opening in the smoke-igniting plate and also having a chamber surrounding the

opening and extended to the heater front, said chamber formed with openings communicating with the outside atmosphere and with openings discharging downwardly into the smoke-burning chamber and a flue at the top of the heater. 15

Des Moines, Iowa, February 10, 1906.

ALBERT M. CLARK.

Witnesses:

CHARLES E. HATCHER,  
MELVA R. INMAN.