



Europäisches Patentamt  
European Patent Office  
Office européen des brevets



(11) **EP 0 874 101 B1**

(12) **EUROPEAN PATENT SPECIFICATION**

(45) Date of publication and mention  
of the grant of the patent:  
**22.11.2000 Bulletin 2000/47**

(51) Int Cl.7: **E04D 13/00**

(21) Application number: **98111027.3**

(22) Date of filing: **12.04.1995**

(54) **A building element and a method of mounting a building element**

Bauelement und Verfahren zur Montierung eines Bauelementes

Élément de construction et méthode de montage d'un élément de construction

(84) Designated Contracting States:  
**AT BE CH DE DK ES FR GB GR IE IT LI LU MC NL  
PT SE**

(72) Inventor: **Soelbeck, Peter**  
**2960 Rungsted Kyst (DK)**

(30) Priority: **15.04.1994 DK 43994**  
**14.10.1994 DK 119394**

(74) Representative: **Nielsen, Henrik Sten**  
**Budde, Schou & Ostenfeld A/S**  
**Vester Søgade 10**  
**1601 Copenhagen V (DK)**

(43) Date of publication of application:  
**28.10.1998 Bulletin 1998/44**

(56) References cited:  
**DE-A- 3 023 037**                    **DE-A- 3 321 101**  
**DE-A- 3 442 276**                    **DE-A- 3 922 624**  
**DE-C- 3 210 017**                    **DE-C- 4 003 906**  
**FI-B- 87 250**                        **US-A- 3 098 663**

(62) Document number(s) of the earlier application(s) in  
accordance with Art. 76 EPC:  
**95916593.7 / 0 760 044**

(73) Proprietor: **MONARFLEX A/S**  
**2730 Herlev (DK)**

**EP 0 874 101 B1**

Note: Within nine months from the publication of the mention of the grant of the European patent, any person may give notice to the European Patent Office of opposition to the European patent granted. Notice of opposition shall be filed in a written reasoned statement. It shall not be deemed to have been filed until the opposition fee has been paid. (Art. 99(1) European Patent Convention).

## Description

**[0001]** The present invention relates to a building element for sealing a hole of a foil of an underroof of a roof structure through which hole access is established from the surroundings into the interior space defined below the roof structure and further relates to a method accordingly.

**[0002]** In a modern building, the roof is most often built from a supporting wooden roof structure including rafters and laths on which tiles or roofing plates are mounted. For providing a hermetic sealing of the interior space defined below the roof structure, i.e. below the tiles or roofing plates, a so-called underroof or undercover produced from a hermetic sealing and water-impermeable foil, most often a plastic foil, is used. The tiles may be made from clay or concrete material and may constitute corrugated tiles, and the roofing plates may be made from slate, clay, concrete or metal materials, such as steel, copper or aluminium sheet material. Provided a hermetic sealing is obtained and maintained by the underroof, rain, snow, and moisture is prevented from contacting and deteriorating the supporting wooden roof structure. Serious problems, however, arise in case holes are to be produced in the underroof, such as holes for chimneys, windows, venting channels, plumbing tubings, etc. as a hermetic sealing round the hole in question is in most instances hard to establish and involves skill.

**[0003]** In connection with window frames for use in roof structures, certain technical solutions involving specific sealing plates to be positioned on top of and below the hole of the underroof in question have been described, e.g. in published Danish Patent Application No. 1232/92. The technical solutions, also including the technical solution suggested in the above published Danish patent application, are, however, not completely satisfactory for numerous reasons, firstly because a reliable and long term lasting sealing cannot be established by means of the known techniques, secondly because the adaptation of the known techniques involves much labour and skill and in many instances is extremely difficult to accomplish. Various other techniques of sealing round chimneys etc. and sealing roofs are known and disclosed in DE 34 42 276, DE 30 32 037, DE 33 21 101, DE 39 22 624, DE 2728836, DE 3210017, DE 4003906, EP 0 284 758 and US 3,098,663, to which reference is made.

**[0004]** It is, therefore, an object of the present invention to provide a novel technique rendering it possible in a simple and reliable manner to seal a hole of a foil of an underroof of a roof structure by means of a building element, eliminating the necessity of involving skilled labour force.

**[0005]** A further object of the present invention is to provide a novel technique of sealing a hole of a foil of an underroof of a roof structure, which technique renders it possible to provide a long term lasting sealing

by means of a simple unitary building element structure.

**[0006]** The above objects together with numerous other objects, features, and advantages, which will be evident from the below detailed description of preferred embodiments of the present invention are according to a first aspect of the present invention obtained by a building element for sealing a hole of a foil of an underroof of a roof structure through which hole access is established from the surroundings into the interior space defined below the roof structure, comprising:

a rim part defining a central aperture of a configuration and a perimeter substantially corresponding to the configuration and perimeter of the hole, a collar part integrally connected to and extending substantially perpendicularly from the rim part and circumferentially encircling the aperture, the rim part and the collar part being made from weather-proof materials, the rim part being adapted to be arranged in substantially co-planar relationship relative to and in facial contact with the foil of the underroof so as to arrange the central aperture of the rim part in registration with the hole of the foil of the underroof and so as to arrange the collar part extending upwardly from the rim part, and fixation means for fixating said rim part relative to a structural element of said roof structure, said fixation means being constituted by a plate segment extending perpendicularly from said rim part and having a through-going bore for receiving a nail, screw or similar fixation element for fixating said plate element to said structural element of said roof structure, or said fixation means being constituted by a hook-shaped fixation means for gripping round said structural element of said roof structure, characterized in further comprising:

a collar element to be fixated within said collar part or to be fixated circumferentially encircling said collar part for sandwiching said foil of said underroof between said collar part and said collar element

**[0007]** The building element according to the present invention constitutes a unitary structure comprising solely two parts, viz. a first part including the rim part and the collar part which are integrally connected at the aperture of the rim part and the collar element, constituting the second part. The building element according to the present invention renders it possible to seal the hole of the foil of the underroof by simply positioning the rim part in co-planar relationship relative to and in facial contact with the foil of the underroof and arranging the central aperture of the rim part in registration with the hole of the foil and sandwiching the foil of the underroof between the collar part and the collar element, consequently, the building element comprising the separate collar element constitutes an assembly by means of which the hole of the underroof is sealed by means of the cooperating collar part and the collar element be-

tween which the foil is sandwiched. Provided the hole constitutes a hole through which boards, such as boards to which a window frame is to be fixated, extend through the hole, the collar part of the building element is easily fixated relative to the boards of the roof structure and preferably, provided the hole is of a specific size, fixated in a tight fit relative to the boards extending through the hole of the underroof, e.g. by means of clamps, nails, screws or the like. The co-planar relationship in which the rim part of the building element is arranged relative to the foil of the underroof may involve arranging the rim part in overlaying or underlaying relationship relative to the foil of the underroof, or a combination of arrangements involving overlaying and underlaying arrangement. Preferably, provided the roof structure is a sloping roof structure, the uppermost foil element is positioned overlaying the rim part and the rim part is positioned overlapping the lowermost foil element in order to guarantee that any rain, snow or moisture, simply due to the gravitational force, is caused to slide down the continuous surface defined by the foil of the underroof and the rim part of the building element. The upwardly protruding or extending collar part prevents the snow or rain from being forced into the aperture of the rim part as the collar part itself constitutes an upwardly protruding part of the building element and, as the collar part is preferably fixated relative to the boards of the roof structure extending through the hole of the underroof to which boards the collar part is fixated. Further the fixation means of the building element according to the present invention serves the purpose of fixating the rim part relative to a structural element of the roof structure. The fixation means may be constituted by a plate segment to be fixated to the structural element of the roof structure, e.g. by means of a nail, a screw or similar fixation element, or alternatively be constituted by a hook-shaped fixation means for gripping round the structural element of the roof structure.

**[0008]** A building element of the type described in the precharacterizing part is known from FI-B-87250.

**[0009]** In order to further improve the sealing round the hole of the underroof as the foil is sandwiched between the collar part and the collar element, the building element may further comprise a sealing O-ring to be received and fixated between the collar part and the collar element.

**[0010]** The separate collar element may, according to a first embodiment, be provided with inwardly extending and separable fins forming cutting guiding means.

**[0011]** According to alternative embodiments of the building element, the O-ring may be received within a circumferential recess of the collar part or the rim part or alternatively be received within a circumferential recess of the collar element.

**[0012]** According to a further embodiment, the rim part may be provided with deformable, strip-like elements for fixating the rim part to a lath by deforming the strip-like elements out of the plane of the rim part. The

rim part may preferably be provided with apertures for passing through a part of the strip-like element. The rim part may be provided with first and second flange elements, the strip-like element being joined to the second flange by means of a hinge-like connection.

**[0013]** The components or parts of the building element are, as stated above, made from weather-proof materials which may be different from one another as the building element may be composed of two separate parts which in a production process are assembled into the unitary building element structure. Thus, one of the parts of the building element may be made from one material, such as a plastic material or a metal material, whereas the other part may be made from a different material, such as a different plastic material or a metal material. According to the presently preferred embodiment of the building element according to the present invention, the rim part and the collar part are, however, made from identical material such as weather-proof plastic material, e.g. high-density polyethylene, low-density polyethylene, polyvinyl chloride, polypropylene or the like, or corrosion-resistant metal, such as aluminium, or combinations thereof.

**[0014]** The building element may in accordance with alternative manufacturing techniques be produced from weldable and castable materials. According to a first embodiment of the building element, the rim part and the collar part are cast from a castable material, such as a plastic material. According to an alternative or second embodiment of the building element according to the present invention, the rim part and the collar part are made from foil materials which are welded together. Provided the building element is made from foil materials, the foil materials are preferably pliable and further preferably foldable materials rendering it possible to produce the building element as an element measuring up to several metres in perimeter, still rendering it possible to store the building element in a small plastic bag which is easily stored, shipped and later on transported by the building worker to the roof for mounting on the supporting roof structure after the building element has been unfolded.

**[0015]** Dependent on the actual application of the building element, and more precisely the actual configuration of the hole and the components to be mounted within the hole through the underroof of the roof structure, the central aperture of the rim part may be rectangularly, triangularly, circularly, elliptically or polygonally configured. In most instances, the building element according to the present invention, however, is of a configuration according to which the aperture of the rim part constitutes a rectangular aperture. Similarly, the rim part may, dependent on the actual application of the building element, define an outer edge of rectangular, triangular, circular, elliptical or polygonal configuration.

**[0016]** In order to ensure that the collar part may be mounted in a tight fit encircling the boards extending through the hole of the underroof, the collar part may

according to a further advantageous embodiment of the building element according to the present invention taper from the rim part towards the outer open end of the collar part.

**[0017]** According to the actual application of the building element, the collar part may in conformity with the structural requirements slope relative to a plane defined by the rim part and consequently e.g. constitute a building element for establishing flashing relative to e.g. a chimney, a vertical venting channel extending through a sloping roof or the like.

**[0018]** According to the presently preferred embodiment of the building element according to the present invention, the building element is adapted to be used for sealing a hole of an underroof, through which hole wooden boards for supporting a window frame define a rectangular hole as the boards are mounted substantially perpendicularly to the surface defined by the foil of the underroof. Consequently, the collar part of the building element according to the present invention preferably extends perpendicularly from the rim part and is preferably composed of segments of planar elements defining segments to be arranged in facial tight fitting contact with the wooden boards of the roof structure.

**[0019]** In order to prevent that any rain or snow which moves downwardly on the upper side of the underroof to which the building element according to the present invention is arranged in accordance with the teachings of the present invention, i.e. having the rim part arranged in substantially co-planar relationship relative to and in facial contact with the foil of the underroof, the building element according to the present invention is preferably further in accordance with an advantageous embodiment provided with a substantially triangularly shaped transition part inter-connecting the rim part and the collar part at the transition therebetween to be positioned at the upper edge of the building element relative to the underroof and extending upwardly from the rim part providing a rain and snow-guide. The rain and snow-guide consequently guides any rain and snow moving down on the upper side of the underroof to either side of the aperture defined within the building element and prevents the snow or rain from falling through the aperture of the building element which aperture is defined by the rim part of the building element and which aperture is circumferentially encircled by the collar part.

**[0020]** According to a further alternative embodiment of the building element according to the present invention, which building element constitutes a universally applicable building element which is adaptable to specific predetermined dimensions of the hole of the underroof, the building element is assembled from two halves together defining the building element comprising the rim part and the collar part. Provided the building element according to the above described advantageous embodiment is assembled from two halves, the two halves are to be arranged in overlapping relationship in order to prevent that rain, snow or moisture may find its way

through any leakage between the two halves which are assembled into a unitary structure circumferentially encircling the hole of the underroof.

**[0021]** The above objects, together with numerous other objects, advantages, and features, which will be evident from the below detailed description of presently preferred embodiments of the present invention are further according to a second aspect of the present invention obtained by a method of sealing a hole of a foil of an underroof of a roof structure through which hole access is established from the surroundings into the interior space defined below the roof structure, and through which hole structural boards of said roof structure extend upwardly from within said interior space, comprising the steps of

i) providing a building element comprising:

a rim part defining a central aperture of a configuration and a perimeter substantially corresponding to the configuration and perimeter of the hole, and  
a collar part integrally connected to and extending substantially perpendicularly from the rim part and circumferentially encircling the aperture, the rim part and the collar part being made from weather-proof materials,

ii) arranging the rim part in substantially co-planar relationship relative to and in facial contact with the foil of the underroof so as to arrange the central aperture of the rim part in registration with the hole of the foil of the underroof and so as to arrange the collar part extending upwardly from the rim part,

iii) fixating the collar part relative to the structural boards of the roof structure, and

iv) fixating said rim part relative to a structural element of said roof structure by means of fixation means being constituted by a plate segment extending perpendicularly from said rim part and having a through-going bore for receiving a nail, screw or similar fixation element for fixating

said plate element to said structural element of said roof structure, or said fixation means being constituted by a hook-shaped fixation means for gripping round said structural element of said roof structure, characterized in further comprising in step i) providing a collar element to be fixated within said collar part or to be fixated circumferentially encircling said collar part for sandwiching said foil of said underroof between said collar part and said collar element, and comprising the additional step of

v) arranging said collar element within said collar part or alternatively circumferentially encircling said collar part for sandwiching said foil of said underroof between said collar part and said collar element.

**[0022]** In accordance with the method according to

the second aspect of the present invention, the building element according to the first aspect of the present invention is used for establishing the sealing of the hole of the foil of the underroof in accordance with the teachings of the present invention. The method according to the second aspect of the present invention, preferably further includes any of the features characteristic of the building element according to the first aspect of the present invention.

**[0023]** The present invention will now be further described with reference to the drawings, in which

Fig. 1 is a perspective and schematic view of a first and presently preferred embodiment of a unitary collar or flashing element according to the present invention,

Fig. 2 is a perspective and schematic view similar to the view of Fig. 1 of a second embodiment of the element according to the present invention,

Fig. 3 is a perspective, schematic and partly sectional view illustrating a technique of applying the first embodiment of the element according to the present invention shown in Fig. 1 in a roof structure in which the element is fixated and sealed relative to an undercover of the roof structure,

Fig. 4 is a perspective and schematic view similar to the view of Fig. 3 illustrating the technique of applying a third embodiment of the element according to the present invention on a roof structure,

Fig. 5 is a perspective and schematic view similar to the views of Figs. 3 and 4, illustrating a fourth embodiment of the element according to the present invention resembling the first embodiment shown in Figs. 1 and 3 and illustrating a technique of trimming the element relative to an application site,

Fig. 6 is a perspective and schematic view illustrating a technique of applying a fifth embodiment of the unitary collar or flashing element according to the present invention relative to a chimney extending through the roof of a building structure,

Fig. 7 is a schematic and sectional view of a roof structure in which tiles are applied on supporting roofing rails and in which a sixth embodiment of the unitary collar or flashing element according to the present invention is applied for sealing the undercover of the roof structure for allowing a tubular venting element to extend through the undercover and a tile of the roof structure,

Fig. 8 is a schematic and sectional view similar to the view of Fig. 7, illustrating a slightly modified ap-

plication of the element shown in Fig. 7,

Fig. 9 is a perspective, schematic and sectional view illustrating the application of the element shown in Figs. 7 and 8, and in particular the fixation of the element as shown in Fig. 8 relative to the supporting roof structure for sealing the undercover of the roof structure,

Fig. 10 is a perspective and schematic view of a seventh embodiment of the unitary collar or flashing element according to the present invention,

Figs. 11 and 12 are perspective and schematic views of a first part of the seventh embodiment of the element according to the present shown in Fig. 10,

Fig. 13 is a perspective and schematic view illustrating a first step of applying the seventh embodiment of the unitary collar or flashing element relative to a roof structure for sealing the undercover of the roof structure in order to allow a tubular venting element to extend through the undercover and through the unitary collar or flashing element,

Fig. 14 is a perspective, schematic and sectional view illustrating an outer rim part of the seventh embodiment of the unitary collar or flashing element shown in Fig. 10 and disclosing an adaptation feature of the unitary collar or flashing element,

Fig. 15 is a perspective and schematic view illustrating a second step of applying the seventh embodiment of the unitary collar or flashing element according to the present invention shown in Fig. 10 relative to the roof structure,

Fig. 16 is a perspective and schematic view similar to the view of Fig. 15 illustrating a final step of applying the seventh embodiment of the unitary collar or flashing element according to the present invention shown in Fig. 10 relative to the roof structure, and

Fig. 17 is a perspective and schematic top view of an eighth embodiment of the unitary collar or flashing element according to the present invention constituting a slightly modified embodiment as compared to the first and presently preferred embodiment shown in Fig. 1, and

Fig. 18 is a perspective and schematic bottom view of the eighth embodiment of the unitary collar or flashing element shown in Fig. 17.

**[0024]** In Fig. 1, a first and presently preferred embodiment of a unitary collar or flashing element according

to the present invention is shown, designated the reference numeral 10 in its entirety. The element 10 is made from a heat-sealable foil material, such as polyethylene, e.g. high-density or low-density polyethylene, or any other weather-proof material, e.g. aluminum foil, polyvinyl chloride or polypropylene foil, or combinations of these materials. The element 10 is composed of a total of four foil segments 12, 14, 16 and 18 which constitute two pairs of foil elements, a first pair comprising the foil elements 12 and 16, and a second pair comprising the foil elements 14 and 18. The foil elements 12 and 16 of the first pair of foil elements are positioned symmetrically relative to an imaginary central axis 20 of the element 10, and the foil elements 14 and 18 of the second pair of foil elements are similarly positioned symmetrically relative to the imaginary central axis 20. The elements 12 and 14 are welded together through a welded joint 13. Similarly, the foil elements 14 and 16, the foil elements 16 and 18 and the foil elements 12 and 18 are welded together through welded joints 15, 17, and 19, respectively.

**[0025]** The element 10 is of an overall structure comprising a substantially plane, circumferential rim part which is composed of the major parts of the foil segments 12, 14, 16, and 18 and which defines a single plane relative to which the imaginary central axis is orthogonal. The overall structure of the element 10 further comprises a collar part which is defined by upwardly turned parts of the foil segments 12, 14, 16, and 18, and which defines a central, substantially rectangular aperture through the element 10 within which aperture the imaginary central axis 20 is located centrally. In Fig. 1, the rim part and the collar part of the element 10 are designated the reference numerals 22 and 24, respectively.

**[0026]** The element 10 is, as mentioned above, preferably made from a foil material such as a plastic foil material which may be heat-shrunk into the overall configuration of the element 10 or alternatively be produced in a combined heat-shrinking and welding process from four separate foil elements which in the combined shrinking and welding process are welded together, shrunk into the overall configuration of the element 10 and further cut along an outer edge 26 of the element defining an overall rectangular outer boundary and along an upper edge 28 of the collar part 24.

**[0027]** The element 10 shown in Fig. 1 is, as will be described in greater detail below with reference to Fig. 3, used for providing an aperture through an undercover of a roof structure, which aperture may be used for the mounting of e.g. a window frame, a chimney, a venting channel element, etc.

**[0028]** In Fig. 2, an alternative or second embodiment of the unitary collar or flashing element according to the present invention is shown, designated the reference numeral 30 in its entirety. The second embodiment 30 differs from the above described first embodiment 10 in that the element is produced as a unitary cast element

made from e.g. high-density polyethylene or a similar plastic material or an appropriate metal material, such as aluminum, defining an outer rim part 32 and a collar part 34 similar to the rim part 22 and the collar part 24 of the element 10 described above with reference to Fig. 1. The rim part 32, like the rim part 22 described above, defines an outer edge 36 of a substantially rectangular configuration. The rim part 32 is of a basically planar structure from which the collar part 34 extends substantially orthogonally upwardly defining an upper edge 38 of a substantially rectangular configuration. The collar part 34 and the rim part 32 are joined together along a substantially rectangular junction 40 which, apart from a minor deviation allowing the element 30 to be removed from a casting matrix corresponds to the rectangular configuration of the upper edge 38 of the collar part 34. The second embodiment 30 may, like the above described first embodiment 10, be modified by e.g. providing the collar element 34 and similarly the collar element 24 as an inwardly sloping collar element defining a reduced upper edge perimeter as compared to the perimeter of the junction 40. Similarly, the rim part 32 may be produced in any alternative appropriate configuration, such as a quadratic configuration, a circular configuration, a triangular configuration, or even a curved configuration for adapting the element to a specific application necessitating the provision of an element of a particular configuration deviating from the configuration shown in Figs. 1 and 2.

**[0029]** Various applications of the unitary collar or flashing element are illustrated in Figs. 3-6 which also illustrate alternative embodiments of the element. In Fig. 3, the first embodiment of the unitary collar or flashing element 10 is mounted on a roof structure which comprises two vertically extending or sloping slating and tilting battens 50 and 52 on top of which an undercover, or a so-called underroof, is mounted. The undercover comprises three undercover sheets 54, 56, and 58 which are applied in overlaying relationship extending substantially horizontally relative to the roof structure as the undercover sheet 54 which is positioned above the undercover sheets 56 and 58 has its lowermost edge part arranged in overlaying relationship relative to the adjacent undercover sheet 56 which in a similar arrangement has its lowermost edge part arranged in overlaying relationship relative to the adjacent undercover sheet 58. Between the battens 50 and 52, a wooden frame support structure is arranged comprising four substantially vertically extending boards 60, 62, 64, and 66. The boards 60, 62, 64, and 66 extend through the undercover foil 66 providing an aperture thereof, within which aperture a window frame structure or e.g. a chimney, a venting channel or the like is to extend. In the primary intentional application of the first embodiment 10 of the unitary collar or flashing element according to the present invention, a window frame is to be mounted on the wooden frame support structure comprising the boards 60, 62, 64, and 66. The element 10 serves the purpose of es-

establishing a hermetic seal along the wooden frame support structure comprising the boards 60, 62, 64, and 66 relative to the undercover comprising the undercover foils 54, 56, and 58 in order to prevent that rain, snow or moisture may be transported into, or alternatively permeate into the roof structure comprising the battens 50 and 52 along the edges of the boards 60, 62, 64, and 66 which might give origin to rot or fungus deterioration of the wood elements of the roof structure, e.g. the battens 50 and 52.

**[0030]** As is evident from Fig. 3, the upper part of the element 10, i.e. the foil segment 18, is positioned underlying the undercover foil 54, whereas the foil segment 14 of the element 10 is positioned overlaying the undercover foil 58 in order to establish an overlaying relationship between the element 10 and the undercover which, like the undercover itself, allows rain, moisture or snow to be transported downwardly along the upper side of the undercover from the uppermost undercover foil 54 to the adjacent undercover foil 56 and further along the undercover without permeating through the undercover. Provided the element 10 is to be used in connection with a window frame which most often is of a specific predetermined configuration defining specific predetermined dimensions, the element 10 is adapted to the configuration and dimensions of the window frame structure in question. Consequently, the outer perimeter of the upper edge 28 of the collar part 24 of the element 10 corresponds to the outer perimeter of the wood frame support structure comprising the boards 60, 62, 64, and 66. Alternatively and preferably, the element 10 is of a somewhat reduced dimension as compared to the outer perimeter of the wood frame support structure in order to establish a hermetical seal between the outer sides of the boards 60, 62, and 64 and the inner side of the collar part 24 of the element 10 as the element 10 has to be mounted in a tight fit enclosing the boards 60, 62, 64, and 66 in which tight fit the foil segments 12, 14, 16, and 18 of the element are caused to be slightly deformed, causing an increase of the perimeter along the upper edge 28 of the collar part 24 of the element 10. The collar part 24 of the element 10 is preferably fixated relative to the boards 60, 62, 64, and 66 by means of nails, seams, bolts, through gluing, etc.

**[0031]** Alternatively, the foil material of the element 10 may be heat-shrinkable, in which case the element 10 is fixated relative to the boards 60, 62, 64, and 66 through shrinking or so-called recovering of the collar part 24 of the element 10 by the application of heat which is generated by means of a gas combustion unit, an electric heating fan, etc. as is well-known within the art of heat-insulating tubings, pipes, etc. The outer circumferential rim part 22 of the element 10 may be sealed to the undercover foils 54, 56, and 58 by means of sealing tape, glue, if appropriate.

**[0032]** In Fig. 3, two frame elements of the window frame structure are shown, one of which is designated the reference numeral 68 and another of which is des-

ignated the reference numeral 70. The frame elements 68 and 70 are both of substantially rectangular configuration and made from L-configured profile plate element, such as extruded aluminum profile elements. The frame element 68 constitutes an inner sealing frame element which is mounted e.g. by means of nails or screws to the outer side of the boards 60, 62, 64, and 66, sandwiching the foil of the collar part 24 of the element 10 between the frame element 68 and the boards. The frame element 70 is mounted, as is illustrated in Fig. 3, in overlapping relationship relative to the frame element 68 as the frame element 70 is fixated to the upper edges of the boards 60, 62, 64, and 66 by means of screws, nails or the like. Alternative frame element structures may, of course, be used in connection with the unitary collar or flashing element according to the present invention for providing a sealing of e.g. a window frame relative to the element 10 and further the undercover of the roof structure.

**[0033]** In Fig. 4, the battens 50, 52, the undercover foils 54, 56, and 58, and further the boards 60, 62, 64, and 66 are further shown together with a slightly modified or third embodiment of the unitary collar or flashing element according to the present invention, which alternative or third embodiment constitutes a modification of the above described second embodiment 30 shown in Fig. 2. The third embodiment is in its entirety designated the reference numeral 30' and is basically produced by cutting the second embodiment 30 into two parts of substantially identical configuration for allowing the element 30' to be adapted to specific longitudinal requirements determined by the length of the boards 60 and 64. The two parts of the element 30' are designated the reference numerals 31' and 33'. Through the application of the two parts 31' and 33' of the element 30', the part 31' is to be positioned in overlapping relationship relative to the part 33' as the part 33' is, as is evident from Fig. 3, mounted prior to the mounting of the part 31'. The two parts 31' and 33' of the third embodiment 30' may preferably be fixated by means of nails or screws, as discussed above with reference to Fig. 3, for fixating the element 30' relative to the boards 60, 62, 64, and 66 to which e.g. a window frame structure is to be mounted.

**[0034]** In Fig. 5, a slightly modified embodiment, or fourth embodiment, of the unitary collar or flashing element according to the present invention is shown, which alternative embodiment constitutes modification of the above described first and presently preferred embodiment 10. The alternative or fourth embodiment shown in Fig. 5 is in its entirety designated the reference numeral 10'. The element 10' is, like the above described first and presently preferred embodiment 10, made from a foil material, such as a pliable foil material, e.g. polyethylene, however differs from the above described first and presently preferred embodiment 10 in that the element 10' is of an overall enlarged configuration. In Fig. 5, elements or components of the embodiment 10' is designated the same reference numerals as applied in

Fig. 1, however, added the additional marking '. The alternative embodiment 10' differs from the above described first and presently preferred embodiment 10 in that the rim part 22' and collar part 24' are enlarged relative to the corresponding elements or parts of the first and presently preferred embodiment 10, allowing that the rim part 22' and the collar part 24' may be trimmed through cutting excessive foil material from the rim and collar parts 22' and 24', respectively, as indicated by flaps 21' and 23' which are cut from or separated from the rim part 22' and similarly through flaps 25' and 27' which are cut or separated from the collar part 24' of the element 10'. The somewhat enlarged rim and collar parts 22' and 24' of the element 10' allow that the element 10' may be adapted or trimmed to a specific application. The element 10' is advantageously made from a heat-shrinkable foil allowing a total adaptation of the element 10 to a specific application through shrinking the element 10' into perfect conformity with the supporting boards 60, 62, 64, and 66 and through cutting excessive material from the rim and collar parts 22' and 24', respectively, as illustrated in Fig. 5.

**[0035]** In Fig. 6, an alternative application of a further or fifth embodiment of the unitary collar or flashing element according to the present invention is shown. In Fig. 6, the fifth embodiment of the element according to the present invention is designated the reference numeral 80 in its entirety and is used for sealing the junction between a chimney 90 and an underroof of a roof surface 92 comprising a plurality of corrugated tiles which are positioned in a manner conventional per se in overlaying or overlapping relationship. The element 80 is basically of a structure similar to the structure of the second embodiment 30 described above with reference to Fig. 2 and is preferably made as a cast plastic product, e.g. cast from high-density polyethylene and comprises a rim part 82 similar to the rim part 32 of the element 30 described above and a collar part 84 similar to the collar part 34 of the element 30 described above. Whereas the collar part 34 of the element 30 extends substantially vertically or orthogonally from the rim part 32 upwardly, the collar part 84 of the element 80 defines an angle different from 90° relative to the substantially plane rim part 82. The angle defined between the collar part 84 and the rim part 82 is determined by the sloping of the roof surface 92 for establishing a perfect sealing contact between the collar part 84 and the outer side surface of the chimney 90 and similarly a perfect sealing contact between the lower side surface of the rim part 82 and the upper side surface of the underroof of the roof surface 92. For sealing the junction between the upper edge of the collar part 84 and the outer surface of the chimney 90, plate elements 86 and 88 are fixated to the outer surface of the chimney 90 and positioned in overlapping relationship relative to the collar part 84 of the element 80.

**[0036]** Whereas the above described first, second, third, fourth, and fifth embodiments of the unitary collar

or flashing element according to the present invention comprise a single element exclusively including a rim part and a collar part, a further or sixth embodiment of the unitary collar or flashing element according to the present invention to be described below with reference to Figs. 7-9 comprise additional sealing elements together with the collar or flashing element providing a sealing assembly. In Figs. 7 and 8, vertical sectional views of a roof structure illustrate two alternative applications of the collar or flashing element or assembly in connection with a roof including corrugated individually positioned tiles or roof plates, such as tiles, e.g. burn tiles or tiles made from concrete or similar material.

**[0037]** In Figs. 7 and 8, the reference numeral 94 designates a rafter of a roof structure on top of which an undercover is applied. The foil of the undercover is designated the reference numeral 96. On top of the rafter 94 along with similar rafters of the roof structure, laths are applied extending parallel with and transversally relative to the rafter 94. The reference numeral 98 designates a lath extending parallel with the rafter 94 and the reference numerals 100 and 102 designate laths extending transversally relative to the rafter 94 and also the lath 98, i.e. horizontally relative to the roof structure. The laths 100 and 102 are positioned mutually spaced apart, serving the primary purpose of supporting corrugated tiles in overlaying relationship as illustrated by a total of three tiles 104, 106, and 108 shown in Figs. 7 and 8. The tiles 104, 106, and 108 are like conventional tiles provided with an upper fixation edge for resting on a supporting lath, such as the laths 100 and 102.

**[0038]** In Figs. 7 and 8, a unitary collar or flashing element or assembly is further shown designated the reference numeral 110 serving the purpose of providing a hermetically sealed aperture through the undercover 96 for allowing a channel, such as a venting channel, to extend from the interior of the building, e.g. from a venting system positioned below the roof structure of the building to the environment or surroundings through the aperture provided within the roof structure. The channel extending through the roof structure is designated the reference numeral 140. In Fig. 7, the channel 140 extends substantially orthogonally relative to the outer surface of the roof defined by the tiles 104, 106, and 108, whereas in Fig. 8, the channel 140 extends substantially vertically through the aperture of the roof and in an angle deviating from 90° relative to the outer surface of the roof structure as defined above. The adaptation of the angular position of the channel 140 relative to the vertical direction and relative to the outer surface of the roof is easily accomplished by shifting the position of the assembly 110 from the position shown in Fig. 7 to the position shown in Fig. 8, which positions differ from one another in that in Fig. 7, the assembly 110 is fixated by means of an edge part of the assembly, to be described in greater details below, at the upper edge of the lath 102, whereas in Fig. 8, the assembly 110 is fixated by means of the above-mentioned edge part to the lower



edge of the lath 102. The position of the assembly 110 may, as will be evident to a person having ordinary skill in the art, be amended and adjusted, if necessary, by simply positioning a specific lath parallel with the laths 100 and 108 and fixating the assembly 110 to the lath. The structure of the element or assembly 110 is now to be described in greater details primarily with reference to Fig. 9 which illustrates the assembly 110 positioned relative to the undercover 96 and fixated to the lath 102 at the lower edge thereof as shown in Fig. 8.

**[0039]** The unitary collar or flashing element or assembly 110 basically comprises two parts or elements 112 and 114 to be positioned on top of and below the undercover 96, respectively. The element or part 112 is basically of a structure similar to the structure of the above described embodiments of the unitary collar or flashing element according to the present invention and comprises a circumferential rim part 116 and a collar part 118. The rim part 116 is at the uppermost end of the assembly 110 and the element 112 provided with a plate element 120 from which two additional plate elements 122 and 124 extend upwardly. The plate elements 122 and 124 define a height corresponding to the height of the laths on which the tile-supporting laths 100 and 102 are supported, i.e. the height of the lath 98. From the plate elements 122 and 124, two triangularly shaped plate elements 126 and 128 extend parallel with the plate element 120 to two fixation plate elements constituting the above-mentioned edge part which are designated the reference numerals 130 and 132, respectively, by means of which the assembly 110 is fixated to the upper or lower edge of the lath 102 by means of e.g. nails or screws. In Figs. 7 and 8, a single nail is shown designated the reference numeral 134 which is mounted in a manner conventional per se by means of a hammer extending through one of the holes extending through the plate elements 130 and 132. Apart from serving as distance elements for keeping the plate element 120 in a specific distance below the plate elements 126 and 128, the plate elements 122 and 124 serve the additional purpose of providing a rain or snow-guide preventing that any rain or snow which is transported downwardly on the upper side of the undercover 96 may fall through the aperture defined by the assembly 110 but instead be transported around the aperture at either side thereof.

**[0040]** The rim part 116 and the collar part 118 of the element 112 are joined together at a junction defining a circumferential recess within which a sealing O-ring is received. The collar part 118 of the element 112 is further provided with through-going apertures, one of which is designated the reference numeral 138, which serve the purpose of cooperating with snap-fitting or bayonet-locking elements of the lower element or part 114 of the assembly 110 for locking or fitting the two elements or parts 112 and 114 together in a sealed and locked position or structure. The element or part 114 is of a structure also resembling the structure of the collar

or flashing element according to the present invention described above with reference to Figs. 1-6 and comprises a circumferential rim part 142 and a circumferential collar part 144 extending upwardly from the rim part 142. The collar part 144 is, as mentioned above, provided with snap-fitting or bayonet-locking elements for cooperating with the apertures 138 of the collar part 118 of the part or element 112 which snap-fitting or bayonet-locking elements are designated the reference numerals 146.

**[0041]** The assembly 110 is mounted in a specific position in the following manner. Firstly, the upper part or element 112 is positioned at the pre-determined position relative to the roof structure and consequently relative to the undercover 96 and fixated relative to the lath 102 by means of nails or screws as discussed above. The upper element or part 112 is, as will be understood, positioned in a central position relative to the unsupported undercover 96, whereas the above-described unitary collar or flashing elements described with reference to Figs. 1-6 are positioned totally supported by the roof structure, such as the battens 50 and 52 shown in Figs. 3 and 4. After the upper part or element 112 has been positioned and fixated, a hole is cut through the undercover 96 through the central aperture defined within the collar part 118 of the element 112, whereupon the lower part or element 114 is introduced through the hole of the undercover 96 from above, turned around and raised into contact with the lower side of the undercover 96 and caused to snap-fit and lock in position relative to the upper part or element 112 through cooperation between the apertures 138 of the collar part 118 of the upper element or part 112 and the snap-fitting or bayonet locking elements 146 of the collar part 144 of the lower element or part 114 as described above. After the lower element or part 114 is snap-fitted into position, the foil of the undercover 96 is sandwiched between the rim and collar parts of the upper and lower elements or parts 112 and 114 and a further sealing is established by means of the sealing O-ring 136. Thereupon, excessive foil material extending upwardly from the assembly may easily be cut away, providing an overall perfectly looking and hermetic sealing of the holes of the undercover, which hole is further water- and snow-proof due to the sloping plate elements 122 and 124 which are described above. A hermetic sealing between the channel, such as the channel 140 shown in Figs. 7 and 8, is, if desired, easily established relative to the assembly 110 by means of e.g. sealing gaskets, sealing foil and tapes, as will be evident to a person having ordinary skill in the art. In many applications, however, a hermetic sealing between the element extending through the assembly 110, such as the channel 140 shown in Figs. 7 and 8, and the assembly 110, is not mandatory and is consequently omitted.

**[0042]** In Fig. 10, a unitary collar or flashing element or assembly constituting a seventh embodiment of the unitary collar or flashing element according to the present invention is shown designated the reference nu-

meral 210 in its entirety. The element or assembly 210 serves the purpose of providing a hermetically sealed aperture through an undercover for allowing a channel, such as a venting channel, to extend from the interior of the building to the environment or surroundings through the aperture provided within the roof structure. Basically, the assembly 210 constitutes an alternative embodiment as compared to the unitary collar or flashing element or assembly 110 described above with reference to Figs. 7 and 8. The assembly 210 comprises like the above described assembly 110 two separate parts or elements 213 and 214. The part or element 212 constitutes an upper part and basically serves the same purpose as the above described element or part 112. Similarly, the element or part 214 constitutes a lower part similar to the above described part or element 114 of the sixth embodiment of the unitary collar or flashing element 110 described above with reference to Figs. 7 and 8. Thus, the element or part 212 comprises a circumferential rim part 216 and a collar part 218. From the collar part 218, two flange parts 217 and 219 extend in opposite directions towards the upper end and the lower end, respectively, of the assembly. The rim part 216 is at its uppermost end of the assembly 210 and the element 212 provided with a plate element 220 from which two additional plate elements 222 and 224 extend upwardly. The plate elements 220 and 224 constitute elements similar to the elements 122 and 124 of the assembly 110 described above and are connected to two basically triangularly shaped plate elements 226 and 228 which extend parallelly with the rim part 216. Similar to the elements 122, 124, 126 and 128 of the assembly 110, the elements 222, 224, 226 and 228 serve the main purpose of provided a rain or snow-guide preventing that any rain or snow may fall through the aperture defined by the through-going aperture of the collar part 218 of the assembly 210.

**[0043]** The assembly 210, however, differs from the above described element 110 in that the assembly 210 is of a structure allowing that the assembly is easily used in connection with roof structures of varying dimensions and in particular in connection with roof structures of different spacing between the laths of the roof structure such as the laths extending substantially horizontally in the roof structure similar to the lath 102 shown in Fig. 9. For accomplishing these adaptation feature, the element 212 is provided with two additional flange elements which extend parallelly with the flange element 217 and 219 from the outer rim of the rim part 216 to a height above the rim part 216 which is identical to the height defined by the flange elements 217 and 219. From the flange elements 230 and 232, which constitute basically vertically extending flange elements, two additional flange elements 234 and 236, respectively, extend outwardly from the outer size of the flange elements 230 and 232, respectively, the flange elements 234 and 236 are positioned parallelly with the rim part 216 and further above the rim part 216 as is illustrated

in Fig. 10. The flange elements 234 and 236 include respective through-going apertures designated the reference numerals 238 and 240, respectively. The assembly 210 further comprises two elongated plate elements 242 and 244 which are connected to the outwardly protruding flange elements 234 and 236, respectively, through hinges 246 and 248, respectively. The elongated plate elements 242 and 244 are provided with through-going holes 250 and 252, respectively, for receiving a nail or a screw for fixating the part or element 212 relative to the roof structure as will be described in greater details below.

**[0044]** In Figs. 11 and 12, the lower element or part 214 of the unitary collar or flashing element or assembly 210 is shown in greater details. The element or part 214 is basically composed of two parts, viz. a rim part 260 and a collar part 262. The collar part 262 defines a through-going aperture in which four separable fins 264 extend inwardly in the plane defined by the rim part 260 and defining an aperture 268. The fins 264 constitute cutting guiding means as will be evident from the below description. From the upper edge of the collar part 262, a plurality of locking elements 266 extend outwardly which locking elements 266 serve the purpose of locking the element or part 214 in position relative to the part or element 212 as the part or element 214 is received by the part or element 212 in the unitary collar or flashing assembly 210 as shown in Fig. 10.

**[0045]** In Figs. 13 and 14, two steps of applying the unitary collar or flashing element or assembly 210 is illustrated. In the first step of applying the assembly 210, the part or element 214 is positioned in its intentional location relative to the sheet 96 of the undercover as is shown in Fig. 13. Thereupon, a knife 280 or similar cutting means is used for cutting a hole through the underroof 96 along a cutting line 282 which line is positioned along the inner rim defined by the fins 264 of the rim part 260 of the part or element 214. As is illustrated in Fig. 13, the part of the underroof which is separated from the major part of the underroof by means of the knife 210 is designated the reference numeral 284. As will be understood, the fins 264 which constitute an integral part of the entire assembly ensures that the aperture which is produced or in most instances cut through the underroof is accurately cut or produced. After the cutting of the aperture through the underroof 96, the fins 264 are separated from the major part of the element 214 as the fins are simply broken from the major part of the element 214 along separation lines shown in Figs. 11 and 12 and allowing that the fins 264 are easily broken or separated from the major part of the element 214.

**[0046]** After the step shown in Fig. 13, the upper part 212 of the assembly 210 is adapted to the specific application in a step illustrated schematically in Fig. 14. The elongated plate elements 214 are bend downwardly from the part or element 212 and the outer ends of the elongated plate elements 242 and 244 are introduced through respective apertures of the flange elements 234

and 236, respectively. At the stage of introducing and receiving the outer ends of the elongated plate elements through a respective apertures of the plate elements 234 and 236, respectively, the element or part 212 is adjusted or adapted to the location of the aperture of the underroof 96 produced as described above with reference to Fig. 13 relative to the position of the laths of the roof structure and also adjusted or adapted to the spacing between the laths of the roof structure as is illustrated in Fig. 15 in which the lath 102 is shown together with the lath 100 shown in phantom lines. As the elongated plate elements 242 and 244 are bend downwardly from the outwardly protruding flange elements 234 and 236, respectively, and as the outer ends of the elongated plate elements 242 and 244 are introduced through specific apertures of the flange elements 234 and 236, a total of four fixation flanges are produced. The fixation flanges produced from the elongated plate element 244 are designated the reference numerals 254 and 256, whereas the fixation flanges produced from the elongated plate element 242 are designated the reference numerals 255 and 257.

**[0047]** After the adjustment or adaptation of the element 210 relative to the roof structure and the aperture of the underroof 96, the element 212 is fixated relative to the roof structure as is illustrated in Fig. 15 as nails or screws are introduced through one or more of the holes of the fixation flanges 256 and 257 and fixated relative to the adjacent lath 102. In Fig. 15, two nails are designated the reference numeral 258 and 259 serving the purpose of fixating the fixation flanges 256 and 257, respectively. Similarly, the fixation flanges 254 and 255 are fixated relative to the lath 100 by means of additional nails, screws or similar fixation means.

**[0048]** As is evident from Fig. 15, the underroof 96 presents a circumferential flap 286 which is initially produced as the hole is cut through the underroof as described above with reference to Fig. 13 along the inner rim of the separable fins 264 of the element 214. Thus, the circumferential flap 286 is accurately dimensioned relative to the through-going aperture defined by the collar part 218 of the element 212 and also correctly positioned relative to the aperture defined by the collar part 218 as the element 212 is adjusted or adapted to the dimensions of the underroof and correctly positioned relative to the underroof as is described above with reference to Figs. 14 and 15.

**[0049]** Finally, the element 214 is introduced from within the interior of the roof and forced outwardly through the aperture defined within the collar part 218 of the element 212 as is illustrated in Fig. 16. At the stage of forcing the element 214 into the through-going aperture defined by the collar part 218 of the element 212, the circumferential flap 286 is sandwiched in between the collar parts 262 and 218 of the elements 214 and 212, respectively, providing a ceiling of the underroof 96 relative to the assembly 210. In the stage of fixating the element 214 relative to the element 212, the locking el-

ements 266 lock the element 214 relative to the element 210 in a snap fitting or bayonet locking mode for fixating and maintaining the element 214 in the position shown in Figs. 10 and 16 relative to the element 212 of the unitary collar of flashing assembly 210.

**[0050]** In Figs. 17 and 18, an eighth and highly advantageous embodiment of the unitary collar or flashing element according to the present invention is shown, designating the reference numeral 310 in its entirety. Basically, the eighth embodiment 310 constitutes a modified embodiment as compared to the above described first and second embodiments shown in Figs. 1 and 2, respectively, further including features of the sixth and seventh embodiments shown in Figs. 7-9 and 10-16, respectively. The eighth embodiment 310 constitutes a unitary cast element made from e.g. high density polyethylene or a similar plastic material or an appropriate metal material, such as aluminum. The element 310 includes a plurality of foil sections, viz. four foil sections 312, 314, 316 and 318 constituting integrally cast foil sections similar to the four foil segments 12, 14, 16 and 18, respectively, of the element 10 described above with reference to Fig. 1. The foil sections 312 and 316 constitute side sections whereas the foil sections 314 and 318 constitute bottom and top sections, respectively, as the terms bottom, top and sides refer to the intentional orientation of the element 310. The element 310 further includes two end foil sections 315 and 319 which are integrally joined to the adjacent bottom and top foil sections 314 and 318, respectively, through weakened or hinged elements 313 and 317, respectively, which allow the end foil sections 315 and 319 to be bent or alternatively separated from the adjacent bottom and top foil sections 314 and 318, respectively, for adapting the overall length of the element 310 to a specific application. Provided the end foil sections 315 and 319 are bent relative to the bottom and top foil sections 314 and 318, respectively, the end foil sections 315 and 319 may be used for fixating the element 310 relative to laths of a roof such as the lath 102 shown in Fig. 7 and 8 by means of e.g. screws, nails or the like.

**[0051]** The above described foil sections 312, 314, 316 and 318 define an integral rim part 322 of the unitary collar of flashing element 310 from which an integral cast collar part 322 protrudes upwardly defining a rim part to be fixated to a wooden board structure of the roof for sealing round the wooden board structure as described above with reference to Figs. 3 and 4. The collar part 324 defines an upper or outer circumferential edge 326 of an overall rectangular configuration.

**[0052]** Whereas the above described first and second embodiments 10 and 30 shown in Figs. 1 and 2, respectively, are of overall symmetrical configuration, the eighth embodiment 310 includes as mentioned above bottom and top foil sections 314 and 318, respectively, providing a structure including an inherent intentional orientation. Thus, whereas the bottom foil section 314 is of a basically plane structure, the top foil section 318

includes an elevated section of an overall triangular configuration defined by upwardly extending plate elements 332, 334 and a plane triangularly shaped top element 330. The elements 330, 332 and 334 basically serve the same purpose as the plate elements 122 and 124 of the unitary collar or flashing element 110 described above with reference to Figs. 7-9, viz. the purpose of providing a rain or snow-guide.

**[0053]** In Fig. 17, the unitary collar or flashing element 310 is shown from the upper side whereas in Fig. 18, the unitary collar or flashing element 310 is shown from the lower side revealing a recess 328 which defines the above described triangularly shaped rain or snow-guide provided by the plate elements 330, 332 and 334 serving the purpose of preventing that any snow or rain which moves down on the upper side of an underlying undercover such as the undercovers 56 and 58 shown in Figs. 3 and 4 falls through the aperture defined by the upwardly protruding collar part 324 of the unitary collar or flashing element 310, but instead be transported round the aperture at either side thereof.

#### Example 1

**[0054]** A prototype implementation of the above described first and presently preferred embodiment of the unitary collar or flashing element 10 described above with reference to Fig. 1 was made from four foil segments of low-density polyethylene of a thickness of 0.5 mm constituting the above described foil segments 12, 14, 16, and 18 which were welded together along welded joints constituting the above described welding joints 13, 15, 17, and 19 defining an overall rectangular outer boundary measuring 176 cm x 129 cm. The foil segments were in the welding process formed into the configuration shown in Fig. 1 defining an upwardly protruding collar part of a height of 16 cm defining a central aperture within the upper edge of the collar part measuring 98 cm x 80 cm. The aperture of the element was located centrally relative to the outer boundary of the element.

#### Example 2

**[0055]** A prototype implementation of the above described second embodiment of the unitary collar or flashing element 30 described above with reference to Fig. 2 was cast from high-density polyethylene. The element defined a configuration similar to the configuration shown in Fig. 2 and defined an outer boundary corresponding to the boundary defined by the edge 36 measuring 117 cm x 95 cm. Centrally within the plate-shaped rim part of the element, an aperture measuring 98 cm x 78 cm and a collar part similar to the collar part 34 described above extended upwardly substantially orthogonally relative to the planar surface defined by the rim part of the element to a height of 8 cm above the upper surface of the rim part of the element.

#### Example 3

**[0056]** A prototype implementation of the above described eighth embodiment of the unitary collar or flashing element 310 described above with reference to Figs. 17 and 18 was cast from high-density polyethylene. The element defined a configuration as shown in Figs. 17 and 18 and defined an outer boundary measuring 1950 mm x 1178 mm. The foil sections 315 and 319 each measured 1178 mm x 150 mm. Centrally within the rim part 322 of the integrally cast or unitary collar or flashing element 310, an aperture defined by the outer edge 326 of the collar part 324 was defined measuring 1398 mm x 778 mm. The height of the snow-guide defined by the plate elements 330, 332 and 334, i.e. the height of the triangularly shaped snow-guide from the upwardly protruding collar part 324 measured 70 mm and the triangularly shaped plate element 330 was elevated 20 mm above the plane defined by the top foil section 318 of the rim part 322.

**[0057]** Although the present invention has been described above with reference to numerous and advantageous embodiments, numerous modifications are obvious to a person having ordinary skill in the art and are to be construed part of the present invention as defined in the appending claims. Although the invention has been described with reference to apertures of overall rectangular configurations as the collar parts of the above described unitary collar or flashing elements have been described in relation to rectangular apertures such as rectangular apertures defined by window frames to be mounted in the roof, the unitary collar or flashing elements according to the present invention are by no means limited to establishing sealing relative to rectangular apertures as the collar part of the unitary collar or flashing element implemented in accordance with the teachings of the present invention may be produced in any arbitrary configuration fulfilling specific requirements, i.e. be configured in circular, rectangular, triangular, quadratic, elliptical configuration or any arbitrary configuration including linear and curved segments or combinations of the above geometrical configurations.

#### **45 Claims**

1. A building element (10, 30, 10', 80, 110, 210, 310) for sealing a hole of a foil (54, 56, 58; 96) of an underroof of a roof structure through which hole access is established from the surroundings into the interior space defined below the roof structure, comprising:

a rim part (22; 32; 22'; 82; 116; 216; 322) defining a central aperture of a configuration and a perimeter substantially corresponding to the configuration and perimeter of said hole, a collar part (24; 34; 24'; 84; 118; 218; 324) in-

- tegrally connected to and extending substantially perpendicularly from said rim part (22; 32; 22'; 82; 116; 216; 322) and circumferentially encircling said aperture, said rim part (22; 32; 22'; 82; 116; 216; 322) and said collar part (24; 34; 24'; 84; 118; 218; 324) being made from weather-proof materials, said rim part (22; 32; 22'; 82; 116; 216; 322) being adapted to be arranged in substantially co-planar relationship relative to and in facial contact with said foil (54, 56, 58; 96) of said underroof so as to arrange said central aperture of said rim part (22; 32; 22'; 82; 116; 216; 322) in registration with said hole of said foil (54, 56, 58; 96) of said underroof and so as to arrange said collar part (24; 34; 24'; 84; 118; 218; 324) extending upwardly from said rim part (22; 32; 22'; 82; 116; 216; 322), and fixation means (130, 132; 234, 236, 242, 244; 315, 319) for fixating said rim part (22; 32; 22'; 82; 116; 216; 322) relative to a structural element (102) of said roof structure, said fixation means (130, 132; 234, 236, 242, 244; 315, 319) being constituted by a plate segment extending perpendicularly from said rim part (22; 32; 22'; 82; 116; 216; 322) and having a through-going bore for receiving a nail, screw or similar fixation element (134; 258) for fixating said plate element to said structural element of said roof structure, or said fixation means being constituted by a hook-shaped fixation means for gripping round said structural element of said roof structure, characterized in further comprising: a collar element to be fixated within said collar part (24; 34; 24'; 84; 118; 218; 324) or to be fixated circumferentially encircling said collar part (24; 34; 24'; 84; 118; 218; 324) for sandwiching said foil (54, 56, 58; 96) of said underroof between said collar part (24; 34; 24'; 84; 118; 218; 324) and said collar element (114; 214).
2. The building element (10, 30, 10', 80, 110, 210, 310) according to claim 1, characterized in said collar element (114; 214) being provided with separable fins (264) extending inwardly into the plane defined by said rim part (22; 32; 22'; 82; 116; 216; 322).
  3. The building element (10, 30, 10', 80, 110, 210, 310) according to claim 1 or 2, characterized in further comprising a sealing O-ring (136) to be received and fixated between said collar part (24; 34; 24'; 84; 118; 218; 324) and said collar element (114; 214).
  4. The building element (10, 30, 10', 80, 110, 210, 310) according to claim 3, characterized in said O-ring (136) being received within a circumferential recess of said collar part (24; 34; 24'; 84; 118; 218; 324) or said rim part (22; 32; 22'; 82; 116; 216; 322).
  5. The building element (10, 30, 10', 80, 110, 210, 310) according to claim 3, characterized in said sealing O-ring (136) being received within a circumferential recess of said collar element (114; 214).
  6. The building element (10, 30, 10', 80, 110, 210, 310) according to any of the claims 1-5, characterized in said rim part (22; 32; 22'; 82; 116; 216; 322) and said collar part (24; 34; 24'; 84; 118; 218; 324) being made from identical materials such as weather-proof plastic materials, e.g. high-density polyethylene, low-density polyethylene, polyvinyl chloride, polypropylene or the like, or corrosion-resistant metal, such as aluminium, or combinations thereof.
  7. The building element (10, 30, 10', 80, 110, 210, 310) according to any of the claims 1-6, characterized in said rim part (22; 32; 22'; 82; 116; 216; 322) and collar part (24; 34; 24'; 84; 118; 218; 324) being cast from a castable material.
  8. The building element (10, 30, 10', 80, 110, 210, 310) according to any of the claims 1-7, characterized in said rim part (22; 32; 22'; 82; 116; 216; 322) and said collar part (24; 34; 24'; 84; 118; 218; 324) being made from foil materials which are welded together.
  9. The building element (10, 30, 10', 80, 110, 210, 310) according to claim 8, characterized in said rim part (22; 32; 22'; 82; 116; 216; 322) and said collar part (24; 34; 24'; 84; 118; 218; 324) being made from foil materials which are pliable and preferably foldable.
  10. The building element (10, 30, 10', 80, 110, 210, 310) according to any of the claims 1-9, characterized in said central aperture of said rim part (22; 32; 22'; 82; 116; 216; 322) being rectangularly, triangularly, circularly, elliptically or polygonally configured.
  11. The building element (10, 30, 10', 80, 110, 210, 310) according to any of the claims 1-10, said rim part (22; 32; 22'; 82; 116; 216; 322) defining an outer edge of rectangular, triangular, circular, elliptical or polygonal configuration.
  12. The building element (10, 30, 10', 80, 110, 210, 310) according to any of the claims 1-10, characterized in said collar part (24; 34; 24'; 84; 118; 218; 324) tapering from said rim part (22; 32; 22'; 82; 116; 216; 322) towards the outer open end of said collar part (24; 34; 24'; 84; 118; 218; 324).
  13. The building element (10, 30, 10', 80, 110, 210, 310) according to any of the claims 1-10, characterized in said rim part (22; 32; 22'; 82; 116; 216; 322) defining a plane and said collar part (24; 34; 24'; 84; 118; 218; 324) sloping relative to said plane defined by said rim part (22; 32; 22'; 82; 116; 216; 322).

14. The building element (10, 30, 10', 80, 110, 210, 310) according to any of the claims 1-10, characterized in said collar part (24; 34; 24'; 84; 118; 218; 324) extending perpendicularly from said rim part (22; 32; 22'; 82; 116; 216; 322).
15. The building element (10, 30, 10', 80, 110, 210, 310) according to any of the claims 1-14, characterized in said collar part (24; 34; 24'; 84; 118; 218; 324) being composed of segments of planar elements (12, 14, 16, 18).
16. The building element (10, 30, 10', 80, 110, 210, 310) according to any of the claims 1-15, characterized in further comprising a substantially triangularly shaped transition part (122, 124; 222, 224; 330, 332, 334) interconnecting said rim part (22; 32; 22'; 82; 116; 216; 322) and said collar part (24; 34; 24'; 84; 118; 218; 324) at the transition there-between and extending upwardly from said rim part (22; 32; 22'; 82; 116; 216; 322) providing a rain or snow-guide.
17. The building element (10, 30, 10', 80, 110, 210, 310) according to any of the claims 1-16, characterized in said building element (10, 30, 10', 80, 110, 210, 310) being assembled from two halves (31', 33') together defining said building element (10, 30, 10', 80, 110, 210, 310) comprising said rim part (22; 32; 22'; 82; 116; 216; 322) and said collar part (24; 34; 24'; 84; 118; 218; 324).
18. The building element (10, 30, 10', 80, 110, 210, 310) according to any of the claims 1-17, said rim part (22; 32; 22'; 82; 116; 216; 322) comprising a strip-like element (242, 244) constituting said fixation means, said strip-like element being arranged at a side of said rim part (22; 32; 22'; 82; 116; 216; 322), said strip-like element (242, 244) may being deformable so as to extend outwardly of the plane of the rim part (22; 32; 22'; 82; 116; 216; 322).
19. The building element (10, 30, 10', 80, 110, 210, 310) according to any of the claims 1-18, characterized in said rim part (22; 32; 22'; 82; 116; 216; 322) being provided with apertures (240) for receiving said deformed, strip-like element (242, 244).
20. The building element (10, 30, 10', 80, 110, 210, 310) according to any of the claims 1-18, characterized in said rim part (22; 32; 22'; 82; 116; 216; 322) comprising a vertically arranged first flange element (230, 232) extending along a side of the rim part (22; 32; 22'; 82; 116; 216; 322), said first flange element (230, 232) being provided with a second flange element (234, 236) extending parallelly with said rim part (22; 32; 22'; 82; 116; 216; 322) having apertures, said second flange element (234, 236) being provided with a hinge (246, 248) connecting said strip-like element (242, 244).
21. A method of sealing a hole of a foil (54, 56, 58; 96) of an underroof of a roof structure through which hole access is established from the surroundings into the interior space defined below the roof structure, and through which hole structural boards of said roof structure extend upwardly from within said interior space, comprising the steps of
- i) providing a building element (10, 30, 10', 80, 110, 210, 310) comprising:
- a rim part (22; 32; 22'; 82; 116; 216; 322) defining a central aperture of a configuration and a perimeter substantially corresponding to the configuration and perimeter of said hole,
- a collar part (24; 34; 24'; 84; 118; 218; 324) integrally connected to and extending substantially perpendicularly from said rim part (22; 32; 22'; 82; 116; 216; 322) and circumferentially encircling said aperture, said rim part (22; 32; 22'; 82; 116; 216; 322) and said collar part (24; 34; 24'; 84; 118; 218; 324) being made from weather-proof materials,
- ii) arranging said rim part (22; 32; 22'; 82; 116; 216; 322) in substantially co-planar relationship relative to and in facial contact with said foil (54, 56, 58; 96) of said underroof so as to arrange said central aperture of said rim part (22; 32; 22'; 82; 116; 216; 322) in registration with said hole of said foil (54, 56, 58; 96) of said underroof and so as to arrange said collar part (24; 34; 24'; 84; 118; 218; 324) extending upwardly from said rim part (22; 32; 22'; 82; 116; 216; 322),
- iii) fixating said collar part (24; 34; 24'; 84; 118; 218; 324) relative to said structural boards (102) of said roof structure, and
- iv) fixating said rim part (22; 32; 22'; 82; 116; 216; 322) relative to a structural element (102) of said roof structure by means of fixation means (130, 132; 234, 236, 242, 244; 315, 319) being constituted by a plate segment extending perpendicularly from said rim part and having a through-going bore for receiving a nail, screw or similar fixation element (134; 258) for fixating said plate element to said structural element of said roof structure, or said fixation means being constituted by a hook-shaped fixation means for gripping round said structural element of said roof structure, characterized in further comprising in step i) providing a collar element (114; 214) to be fixated within said collar part

(24; 34; 24'; 84; 118; 218; 324) or to be fixated circumferentially encircling said collar part (24; 34; 24'; 84; 118; 218; 324) for sandwiching said foil (54, 56, 58; 96) of said underroof between said collar part (24; 34; 24'; 84; 118; 218; 324) and said collar element (114; 214), and comprising the additional step of  
 v) arranging said collar element (114; 214) within said collar part (24; 34; 24'; 84; 118; 218; 324) or alternatively circumferentially encircling said collar part (24; 34; 24'; 84; 118; 218; 324) for sandwiching said foil (54, 56, 58; 96) of said underroof between said collar part (24; 34; 24'; 84; 118; 218; 324) and said collar element (114; 214).

22. The method according to claim 21, characterized in said rim part (22; 32; 22'; 82; 116; 216; 322) and said foil (54, 56, 58; 96) of said underroof being positioned in mutual overlaying relationship, i.e. said rim part (22; 32; 22'; 82; 116; 216; 322) being positioned overlaying and/or underlaying, or alternatively partly overlaying and partly underlaying said foil (54, 56, 58; 96) of said underroof.

#### Patentansprüche

1. Bauelement (10, 30, 10', 80, 110, 210, 310) zum Abdichten eines Lochs einer Folie (54, 56, 58, 96) einer Dachunterkonstruktion einer Dachstruktur, wobei durch dieses Loch ein Zugang von der Umgebung in den Innenraum unterhalb der Dachstruktur möglich ist, umfassend:

einen Randabschnitt (22, 32, 22', 82, 116, 216, 322), der eine zentrale Öffnung mit einer Konfiguration und einem Umfang begrenzt, welche im wesentlichen der Konfiguration und dem Umfang des Lochs entsprechen,  
 einen Kragenabschnitt (24, 34, 24', 84, 118, 218, 324), der auf integrale Weise mit dem Randabschnitt (22, 32, 22', 82, 116, 216, 322) verbunden ist und sich im wesentlichen senkrecht von diesem Randabschnitt (22, 32, 22', 82, 116, 216, 322) erstreckt, und der die Öffnung umfänglich umgibt, wobei der Randabschnitt (22, 32, 22', 82, 116, 216, 322) und der Kragenabschnitt (24, 34, 24', 84, 118, 218, 324) aus wetterfesten Materialien hergestellt sind, wobei der Randabschnitt (22, 32, 22', 82, 116, 216, 322) dazu geeignet ist, in einer im wesentlichen koplanaren Beziehung relativ zu und in gegenüberliegendem Kontakt mit der Folie (54, 56, 58, 96) der Dachunterkonstruktion angeordnet zu werden, um auf diese Weise die zentrale Öffnung des Randabschnitts (22, 32, 22', 82, 116, 216, 322) genau zum Loch der Folie

(54, 56, 58, 96) der Dachunterkonstruktion passend anzuordnen und um den Kragenabschnitt (24, 34, 24', 84, 118, 218, 324) so anzuordnen, daß er sich vom Randabschnitt (22, 32, 22', 82, 116, 216, 322) nach oben hin erstreckt, und ein Befestigungsmittel (130, 132, 234, 236, 242, 244, 315, 319) zur Befestigung des Randabschnitts (22, 32, 22', 82, 116, 216, 322) relativ zu einem Strukturelement (102) der Dachstruktur, wobei das Befestigungsmittel (130, 132, 234, 236, 242, 244, 315, 319) aus einem Plattensegment besteht, das sich senkrecht vom Randabschnitt (22, 32, 22', 82, 116, 216, 322) erstreckt und eine durchgehende Bohrung zur Aufnahme eines Nagels, einer Schraube oder eines ähnlichen Befestigungselements (134, 258) zur Befestigung des Plattenelements am Strukturelement der Dachstruktur besitzt, oder wobei das Befestigungsmittel von einem hakenförmigen Befestigungsmittel gebildet wird, um das Strukturelement der Dachstruktur zu umfassen, dadurch gekennzeichnet, daß es weiter umfaßt: ein Kragenelement, welches innerhalb des Kragenabschnitts (24, 34, 24', 84, 118, 218, 324) zu befestigen ist oder so zu befestigen ist, daß es den Kragenabschnitt (24, 34, 24', 84, 118, 218, 324) entlang seines Umfangs umgibt, um die Folie (54, 56, 58, 96) der Dachunterkonstruktion zwischen dem Kragenabschnitt (24, 34, 24', 84, 118, 218, 324) und dem Kragenelement (114, 214) anzuordnen.

2. Bauelement (10, 30, 10', 80, 110, 210, 310) nach Anspruch 1, dadurch gekennzeichnet, daß das Kragenelement (114, 214) mit abnehmbaren Rippen (264) ausgestattet ist, die sich nach innen in die Ebene erstrecken, die vom Randabschnitt (22, 32, 22', 82, 116, 216, 322) begrenzt wird.
3. Bauelement (10, 30, 10', 80, 110, 210, 310) nach Anspruch 1 oder 2, dadurch gekennzeichnet, daß es weiter einen O-Ring (136) umfaßt, der zwischen dem Kragenabschnitt (24, 34, 24', 84, 118, 218, 324) und dem Kragenelement (114, 214) aufgenommen und darin fixiert wird.
4. Bauelement (10, 30, 10', 80, 110, 210, 310) nach Anspruch 3, dadurch gekennzeichnet, daß der O-Ring (136) innerhalb einer umfänglichen Aussparung des Kragenabschnitts (24, 34, 24', 84, 118, 218, 324) oder des Randabschnitts (22, 32, 22', 82, 116, 216, 322) aufgenommen wird.
5. Bauelement (10, 30, 10', 80, 110, 210, 310) nach Anspruch 3, dadurch gekennzeichnet, daß der O-Ring (136) innerhalb einer umfänglichen Aussparung des Kragenelements (114, 214) aufgenom-

- men wird.
6. Bauelement (10, 30, 10', 80, 110, 210, 310) nach einem der Ansprüche 1-5, dadurch gekennzeichnet, daß der Randabschnitt (22, 32, 22', 82, 116, 216, 322) und der Kragenabschnitt (24, 34, 24', 84, 118, 218, 324) aus den gleichen Materialien hergestellt sind, wie zum Beispiel aus wetterfesten Kunststoffmaterialien, wie z.B. hochdichtem Polyethylen, geringdichtem Polyethylen, Polyvinylchlorid, Polypropylen oder ähnlichem, oder aus korrosionsbeständigem Metall, wie zum Beispiel Aluminium, oder Kombinationen davon. 5
7. Bauelement (10, 30, 10', 80, 110, 210, 310) nach einem der Ansprüche 1-6, dadurch gekennzeichnet, daß der Randabschnitt (22, 32, 22', 82, 116, 216, 322) und der Kragenabschnitt (24, 34, 24', 84, 118, 218, 324) aus einem gießbaren Material gegossen werden. 10
8. Bauelement (10, 30, 10', 80, 110, 210, 310) nach einem der Ansprüche 1-7, dadurch gekennzeichnet, daß der Randabschnitt (22, 32, 22', 82, 116, 216, 322) und der Kragenabschnitt (24, 34, 24', 84, 118, 218, 324) aus Folienmaterialien hergestellt werden, die zusammengeschweißt werden. 15
9. Bauelement (10, 30, 10', 80, 110, 210, 310) nach Anspruch 8, dadurch gekennzeichnet, daß der Randabschnitt (22, 32, 22', 82, 116, 216, 322) und der Kragenabschnitt (24, 34, 24', 84, 118, 218, 324) aus Folienmaterialien hergestellt werden, die biegsam und vorzugsweise faltbar sind. 20
10. Bauelement (10, 30, 10', 80, 110, 210, 310) nach einem der Ansprüche 1-9, dadurch gekennzeichnet, daß die zentrale Öffnung des Randabschnitts (22, 32, 22', 82, 116, 216, 322) rechteckig, dreieckig, kreisförmig, elliptisch oder polygonal ist. 25
11. Bauelement (10, 30, 10', 80, 110, 210, 310) nach einem der Ansprüche 1-10, wobei der Randabschnitt (22, 32, 22', 82, 116, 216, 322) eine Außenkante mit rechteckiger, dreieckiger, kreisförmiger, elliptischer oder polygonaler Konfiguration begrenzt. 30
12. Bauelement (10, 30, 10', 80, 110, 210, 310) nach einem der Ansprüche 1-10, dadurch gekennzeichnet, daß der Kragenabschnitt (24, 34, 24', 84, 118, 218, 324) vom Randabschnitt (22, 32, 22', 82, 116, 216, 322) hin zu einem äußeren offenen Ende des Kragenabschnitts (24, 34, 24', 84, 118, 218, 324) kegelförmig zuläuft. 35
13. Bauelement (10, 30, 10', 80, 110, 210, 310) nach einem der Ansprüche 1-10, dadurch gekennzeichnet, daß der Randabschnitt (22, 32, 22', 82, 116, 216, 322) eine Ebene definiert und der Kragenabschnitt (24, 34, 24', 84, 118, 218, 324) relativ zur Ebene, die vom Randabschnitt (22, 32, 22', 82, 116, 216, 322) definiert wird, abfällt. 40
14. Bauelement (10, 30, 10', 80, 110, 210, 310) nach einem der Ansprüche 1-10, dadurch gekennzeichnet, daß sich der Kragenabschnitt (24, 34, 24', 84, 118, 218, 324) senkrecht vom Randabschnitt (22, 32, 22', 82, 116, 216, 322) weg erstreckt. 45
15. Bauelement (10, 30, 10', 80, 110, 210, 310) nach einem der Ansprüche 1-14, dadurch gekennzeichnet, daß der Kragenabschnitt (24, 34, 24', 84, 118, 218, 324) aus Segmenten flacher Elemente (12, 14, 16, 18) zusammengesetzt ist. 50
16. Bauelement (10, 30, 10', 80, 110, 210, 310) nach einem der Ansprüche 1-15, dadurch gekennzeichnet, daß er weiter einen im wesentlichen dreieckig geformten Übergangabschnitt (122, 124, 222, 224, 330, 332, 334) umfaßt, der den Randabschnitt (22, 32, 22', 82, 116, 216, 322) und den Kragenabschnitt (24, 34, 24', 84, 118, 218, 324) am dazwischenliegenden Übergang miteinander verbindet und sich vom Randabschnitt (22, 32, 22', 82, 116, 216, 322) nach oben hin erstreckt, um dadurch eine Regen- oder Schneeführung zu bilden. 55
17. Bauelement (10, 30, 10', 80, 110, 210, 310) nach einem der Ansprüche 1-16, dadurch gekennzeichnet, daß das Bauelement (10, 30, 10', 80, 110, 210, 310) aus zwei Hälften (31', 33') zusammengebaut ist, die gemeinsam das Bauelement (10, 30, 10', 80, 110, 210, 310) umfassend den Randabschnitt (22, 32, 22', 82, 116, 216, 322) und den Kragenabschnitt (24, 34, 24', 84, 118, 218, 324) definieren.
18. Bauelement (10, 30, 10', 80, 110, 210, 310) nach einem der Ansprüche 1-17, wobei der Randabschnitt (22, 32, 22', 82, 116, 216, 322) ein streifenähnliches Element (242, 244) umfaßt, welches das Befestigungsmittel darstellt, wobei das streifenähnliche Element an einer Seite des Randabschnitts (22, 32, 22', 82, 116, 216, 322) angeordnet ist, wobei das streifenähnliche Element (242, 244) verformbar sein kann, um sich aus der Ebene des Randabschnitts (22, 32, 22', 82, 116, 216, 322) nach außen hin zu erstrecken.
19. Bauelement (10, 30, 10', 80, 110, 210, 310) nach einem der Ansprüche 1-18, dadurch gekennzeichnet, daß der Randabschnitt (22, 32, 22', 82, 116, 216, 322) mit Öffnungen (240) zur Aufnahme des verformten, streifenähnlichen Elements (242, 244) ausgestattet ist.



20. Bauelement (10, 30, 10', 80, 110, 210, 310) nach einem der Ansprüche 1-18, dadurch gekennzeichnet, daß der Randabschnitt (22, 32, 22', 82, 116, 216, 322) ein vertikal angeordnetes, erstes Flanschelement (230, 232) umfaßt, das sich entlang einer Seite des Randabschnitts (22, 32, 22', 82, 116, 216, 322) erstreckt, wobei das erste Flanschelement (230, 232) mit einem zweiten Flanschelement (234, 236) ausgestattet ist, das sich parallel zum Randabschnitt (22, 32, 22', 82, 116, 216, 322) erstreckt und Öffnungen aufweist, wobei das zweite Flanschelement (234, 236) mit einem Scharnier (246, 248) ausgestattet ist, welches das streifenähnliche Element (242, 244) verbindet.
21. Verfahren zum Abdichten eines Lochs in einer Folie (54, 56, 58, 96) einer Dachunterkonstruktion einer Dachstruktur, durch welches ein Zugang von der Umgebung in den Innenraum möglich ist, der unter der Dachstruktur definiert ist, und durch welches sich Strukturbretter der Dachstruktur vom Innenraum her nach oben hin erstrecken, umfassend die folgenden Schritte:
- i) das Schaffen eines Bauelements (10, 30, 10', 80, 110, 210, 310), umfassend:
- einen Randabschnitt (22, 32, 22', 82, 116, 216, 322), der eine zentrale Öffnung mit einer Konfiguration und einem Umfang definiert, die im wesentlichen der Konfiguration und dem Umfang des Lochs entsprechen,
- einen Kragenabschnitt (24, 34, 24', 84, 118, 218, 324), der auf integrale Weise mit dem Randabschnitt (22, 32, 22', 82, 116, 216, 322) verbunden ist und sich im wesentlichen senkrecht von diesem Randabschnitt (22, 32, 22', 82, 116, 216, 322) erstreckt und der die Öffnung umfänglich umgibt, wobei der Randabschnitt (22, 32, 22', 82, 116, 216, 322) und der Kragenabschnitt (24, 34, 24', 84, 118, 218, 324) aus wetterfesten Materialien hergestellt sind,
- ii) das Anordnen des Randabschnitts (22, 32, 22', 82, 116, 216, 322) in einer im wesentlichen koplanaren Beziehung relativ zu und in gegenüberliegendem Kontakt mit der Folie (54, 56, 58, 96) der Dachunterkonstruktion, um auf diese Weise die zentrale Öffnung des Randabschnitts (22, 32, 22', 82, 116, 216, 322) genau zum Loch der Folie (54, 56, 58, 96) der Dachunterkonstruktion passend anzuordnen und um den Kragenabschnitt (24, 34, 24', 84, 118, 218, 324) so anzuordnen, daß er sich vom Randabschnitt (22, 32, 22', 82, 116, 216, 322) nach oben hin erstreckt,

- iii) das Fixieren des Kragenabschnitts (24, 34, 24', 84, 118, 218, 324) relativ zu den Strukturbrettern (102) der Dachstruktur, und
- iv) das Fixieren des Randabschnitts (22, 32, 22', 82, 116, 216, 322) relativ zu einem Strukturelement (102) der Dachstruktur mit Hilfe eines Befestigungsmittels (130, 132, 234, 236, 242, 244, 315, 319), das aus einem Plattensegment besteht, welches sich senkrecht vom Randabschnitt erstreckt und eine durchgehende Bohrung zur Aufnahme eines Nagels, einer Schraube oder eines ähnlichen Befestigungselements (134, 258) zur Befestigung des Plattenelements am Strukturelement der Dachstruktur besitzt, oder wobei das Befestigungsmittel aus einem hakenförmigen Befestigungsmittel gebildet wird, um das Strukturelement der Dachstruktur zu umfassen, dadurch gekennzeichnet, daß weiter umfaßt ist in Schritt i) das Schaffen eines Kragenelements (114, 214), das innerhalb des Kragenabschnitts (24, 34, 24', 84, 118, 218, 324) zu befestigen ist oder so zu befestigen ist, daß es den Kragenabschnitt (24, 34, 24', 84, 118, 218, 324) entlang seines Umfangs umgibt, um die Folie (54, 56, 58, 96) der Dachunterkonstruktion zwischen den Kragenabschnitt (24, 34, 24', 84, 118, 218, 324) und das Kragenelement (114, 214) zu legen, und umfassend den zusätzlichen Schritt des
- v) Anordnens des Kragenelements (114, 214) innerhalb des Kragenabschnitts (24, 34, 24', 84, 118, 218, 324) oder alternativ dazu des Umgebens des Kragenabschnitts (24, 34, 24', 84, 118, 218, 324), entlang seines Umfangs um die Folie (54, 56, 58, 96) der Dachunterkonstruktion zwischen den Kragenabschnitt (24, 34, 24', 84, 118, 218, 324) und das Kragenelement (114, 214) zu legen.

22. Verfahren nach Anspruch 21, dadurch gekennzeichnet, daß der Randabschnitt (22, 32, 22', 82, 116, 216, 322) und die Folie (54, 56, 58, 96) der Dachunterkonstruktion in einer wechselseitig übereinanderliegenden Beziehung angeordnet sind, das heißt, daß der Randabschnitt (22, 32, 22', 82, 116, 216, 322) über und/oder unter oder alternativ dazu teilweise über und teilweise unter der Folie (54, 56, 58, 96) der Dachunterkonstruktion liegt.

## Revendications

1. Élément (10,30,10',80,110,210,310) de construction pour étanchéifier un trou d'une feuille (54,56,58 ;96) d'un sous-toit d'une structure de toit, trou par lequel il est établi un accès de ce qui est autour à l'espace intérieur défini en-dessous de la

structure du toit, comprenant :

une partie (22 ;32 ;22' ;82 ;116 ;216 ;322) formant bord définissant une ouverture centrale de configuration et de périmètre correspondant sensiblement à la configuration et au périmètre du trou,

une partie (24 ;34 ;24' ;84 ;118 ;218 ;324) formant collet, reliée d'une pièce à la partie (22 ;32 ;22' ;82 ;116 ;216 ;322) formant bord et s'étendant sensiblement perpendiculairement à celle-ci et entourant circonférentiellement l'ouverture, la partie (22 ;32 ;22' ;82 ;116 ;216 ;322) formant bord et la partie (24 ;34 ;24' ;84 ;118 ;218 ;324) formant collet étant en des matériaux à l'épreuve des intempéries, la partie (22 ;32 ;22' ;82 ;116 ;216 ;322) formant bord étant propre à être disposée de manière sensiblement coplanaire par rapport à la feuille (54,56,58 ;96) du sous-toit et en contact facial avec celle-ci de manière à faire coïncider l'ouverture centrale de la partie (24 ;32 ;22' ;82 ;116 ;216 ;322) formant bord avec le trou de la feuille (54,56,58 ;96) du sous-toit, et à faire que la partie (24 ;34 ;24' ;84 ;118 ;218 ;324) formant collet s'étende vers le haut à partir de la partie (22 ;32 ;22' ;82 ;116 ;216 ;322) formant bord et

des moyens (130,132 ;234,236,242,244 ;315,319) de fixation de la partie (22 ;32 ;22' ;82 ;116 ;216 ;322) formant bord par rapport à un élément (102) structural de la structure du toit, les moyens (130,132 ;234,236,242,244 ;315,319) de fixation étant constitués d'un segment de plaque s'étendant perpendiculairement à la partie (22 ;32 ;22' ;82 ;116 ;216 ;322) formant bord et ayant un trou traversant de réception d'un clou, d'une vis ou d'un élément (134 ;258) analogue de fixation pour fixer l'élément en forme de plaque à l'élément structural de la structure du toit, ou les moyens de fixation sont constitués par des moyens de fixation en forme de crochet pour accrocher l'élément structural de la structure de toit, caractérisé en ce qu'il comprend en outre : un élément de collet destiné à être fixé dans la partie (24 ;34 ;24' ;84 ;118 ;218 ;324) formant collet ou à être fixé en entourant circonférentiellement la partie (24 ;34 ;24' ;84 ;118 ;218 ;324) formant collet pour prendre la feuille (54,56,58 ;96) du sous-toit en sandwich entre la partie (24,34,24',84,118 ;218 ;324) formant collet et l'élément (114 ;214) de collet.

2. Elément (10,30,10',80,110,210,310) de construction suivant la revendication 1, caractérisé en ce que l'élément (114 ;214) de collet est muni d'ailettes (264) pouvant être séparées et s'étendant vers l'in-

térieur dans le plan défini par la partie (22 ;32 ;22' ;82 ;116 ;216 ;322) formant bord.

3. Elément (10,30,10',80,110,210,310) de construction suivant la revendication 1 ou 2, caractérisé en ce qu'il comprend en outre un joint (136) torique d'étanchéité destiné à être reçu et à être fixé entre la partie (24 ;34 ;24' ;84 ;118 ;218 ;324) formant collet et l'élément (114 ;214) de collet.
4. Elément (10,30,10',80,110,210,310) de construction suivant la revendication 3, caractérisé en ce que le joint (136) torique est reçu dans une cavité circonférentielle de la partie (24 ;34 ;24' ;84 ;118 ;218 ;324) formant collet ou de la partie (22 ;32 ;22' ;82 ;116 ;216 ;322) formant bord.
5. Elément (10,30,10',80,110,210,310) de construction suivant la revendication 3, caractérisé en ce que le joint (136) torique d'étanchéité est reçu dans une cavité circonférentielle de l'élément (114 ;214) de collet.
6. Elément (10,30,10',80,110,210,310) de construction suivant l'une quelconque des revendications 1 à 5, caractérisé en ce que la partie (22 ;32 ;22' ;82 ;116 ;216 ;322) formant bord et la partie (24 ;34 ;24' ;84 ;118 ;218 ;324) formant collet sont en des matériaux identiques tels que des matières plastiques à l'épreuve des intempéries, par exemple du polyéthylène haute densité, du polyéthylène basse densité, du poly(chlorure de vinyle), du polypropylène ou analogue, ou en métal résistant à la corrosion, tel qu'en aluminium ou en leurs combinaisons.
7. Elément (10,30,10',80,110,210,310) de construction suivant l'une quelconque des revendications 1 à 6, caractérisé en ce que la partie (22 ;32 ;22' ;82 ;116 ;216 ;322) formant bord et la partie (24 ;34 ;24' ;84 ;118 ;218 ;324) formant collet sont coulées dans un matériau pouvant être coulé.
8. Elément (10,30,10',80,110,210,310) de construction suivant l'une quelconque des revendications 1 à 7, caractérisé en ce que la partie (22 ;32 ;22' ;82 ;116 ;216 ;322) formant bord et la partie (24 ;34 ;24' ;84 ;118 ;218 ;324) formant collet sont en des matériaux en feuille qui sont soudés ensemble.
9. Elément (10,30,10',80,110,210,310) de construction suivant la revendication 8, caractérisé en ce que la partie (22 ;32 ;22' ;82 ;116 ;216 ;322) formant bord et la partie (24 ;34 ;24' ;84 ;118 ;218 ;324) formant collet sont en des matériaux en feuille qui peuvent être courbés et, de préférence, pliés.
10. Elément (10,30,10',80,110,210,310) de construction suivant l'une quelconque des revendications 1

à 9, caractérisé en ce que l'ouverture centrale de la partie (22 ;32 ;22' ;82 ;116 ;216 ;322) formant bord est rectangulaire, triangulaire, circulaire, elliptique ou polygonale.

- 5
11. Elément (10,30,10',80,110,210,310) de construction suivant l'une quelconque des revendications 1 à 10, dans lequel la partie (22 ;32 ;22' ;82 ;116 ;216 ;322) formant bord définit un bord extérieur de configuration rectangulaire, triangulaire, circulaire, elliptique ou polygonale.
- 10
12. Elément (10,30,10',80,110,210,310) de construction suivant l'une quelconque des revendications 1 à 10, caractérisé en ce que la partie (24 ;34 ;24' ;84 ;118 ;218 ;324) formant collet se rétrécit de la partie (22 ;32 ;22' ;82 ;116 ;216 ;322) formant bord vers l'extrémité extérieure ouverte de la partie (24 ;34 ;24' ;84 ;118 ;218 ;324) formant collet.
- 15
13. Elément (10,30,10',80,110,210,310) de construction suivant l'une quelconque des revendications 1 à 10, caractérisé en ce que la partie (22 ;32 ;22' ;82 ;116 ;216 ;322) formant bord définit un plan et la partie (24 ;34 ;24' ;84 ;118 ;218 ;324) formant collet est inclinée par rapport au plan défini par la partie (22 ;32 ;22' ;82 ;116 ;216 ;322) formant bord.
- 20
14. Elément (10,30,10',80,110,210,310) de construction suivant l'une des revendications 1 à 10, caractérisé en ce que la partie (24 ;34 ;24' ;84 ;118 ;218 ;324) formant collet s'étend perpendiculairement à la partie (22 ;32 ;22' ;82 ;116 ;216 ;322) formant bord.
- 25
15. Elément (10,30,10',80,110,210,310) de construction suivant l'une des revendications 1 à 14, caractérisé en ce que la partie (24 ;34 ;24' ;84 ;118 ;218 ;324) formant collet est composée de segments d'éléments (12,14,16,18) plans.
- 30
16. Elément (10,30,10',80,110,210,310) de construction suivant l'une quelconque des revendications 1 à 15, caractérisé en ce qu'il comprend en outre une partie (122,124 ;222,224 ;330,332,334) de transition de forme sensiblement triangulaire reliant la partie (22 ;32 ;22' ;82 ;116 ;216 ;322) formant bord et la partie (24 ;34 ;24' ;84 ;118 ;218 ;324) formant collet à leur point de transition et s'étendant vers le haut à partir de la partie (22 ;32 ;22' ;82 ;116 ;216 ;322) formant bord en ménageant une gouttière pour la pluie ou pour la neige.
- 35
17. Elément (10,30,10',80,110,210,310) de construction suivant l'une quelconque des revendications 1 à 16, caractérisé en ce que l'élément (10,30,10',80,110,210,310) de construction est assemblé à partir de deux moitiés (31',33') définissant ensem-
- 40
- 45
- 50
- 55

ble l'élément (10,30,10',80,110,210,310) de construction comprenant la partie (22 ;32 ;22' ;82 ;116 ;216 ;322) formant bord et la partie (24 ;34 ;24' ;84 ;118 ;218 ;324) formant collet.

18. Elément (10,30,10',80,110,210,310) de construction suivant l'une quelconque des revendications 1 à 17, la partie (22 ;32 ;22' ;116 ;216 ;322) formant bord comprenant un élément (242,244) en forme de bande constituant les moyens de fixation, l'élément en forme de bande étant disposé d'un côté de la partie (22 ;32 ;22' ;82 ;116 ;216 ;322) formant bord, l'élément (242,244) en forme de bande pourra être déformé de manière à s'étendre à l'extérieur du plan de la partie (22 ;32 ;22' ;82 ;116 ;216 ;322) formant bord.
19. Elément (10,30,10',80,110,210,310) de construction suivant l'une quelconque des revendications 1 à 18, caractérisé en ce que la partie (22 ;32 ;22' ;82 ;116 ;216 ;322) formant bord est munie d'ouvertures (240) de réception de l'élément (242,244) déformé en forme de bande.
- 20
20. Elément (10,30,10',80,110,210,310) de construction suivant l'une quelconque des revendications 1 à 18, caractérisé en ce que la partie (22 ;32 ;22' ;82 ;116 ;216 ;322) formant bord comprend un premier élément (230,232) de bride disposé verticalement, s'étendant le long d'un côté de la partie (22 ;32 ;22' ;82 ;116 ;216 ;322) formant bord, le premier élément (230,232) de bride étant muni d'un deuxième élément (234,236) de bride, s'étendant parallèlement à la partie (22 ;32 ;22' ;82 ;116 ;216 ;322) formant bord ayant des ouvertures, le deuxième élément (234,236) formant bride étant muni d'une charnière (246,248) reliant l'élément (242,244) en forme de bande.
- 25
21. Procédé pour rendre étanche un trou d'une feuille (54,56,58 ;96) d'un sous-toit d'une structure de toit, trou par lequel il est établi un accès de ce qui est autour à l'espace intérieur défini en-dessous de la structure du toit, et trou par lequel des panneaux structuraux de la structure du toit s'étend vers le haut à partir de l'espace intérieur, le procédé consistant:
- 30
- 35
- 40
- 45
- 50
- 55
- i) à prévoir un élément (10,30,10',80,110,210,310) de construction comprenant :
- une partie (22 ;32 ;22' ;82 ;116 ;216 ;322) de bord définissant une ouverture centrale de configuration et périmètre correspondant sensiblement à la configuration et aux périmètres du trou,
- une partie (24 ;34 ;24' ;84 ;118 ;218 ;324) formant collet, d'une pièce avec la partie

(22 ;32 ;22' ;82 ;116 ;216 ;322) formant bord et lui étant sensiblement perpendiculaire et entourant circonférentiellement l'ouverture, la partie (22 ;32 ;22' ;82 ;116 ;216 ;322) formant bord et la partie (24 ;34 ;24' ;84 ;118 ;218 ;324) formant collet étant dans des matériaux à l'épreuve des intempéries,

ii) à disposer la partie (22 ;32 ;22' ;82 ;116 ;216 ;322) formant bord d'une manière sensiblement coplanaire à la feuille (54,56,58 ;96) du sous-toit et en contact facial avec celle-ci, de manière à mettre l'ouverture centrale de la partie (22 ;32 ;22' ;82 ;116 ;216 ;322) formant bord en coïncidence avec le trou de la feuille (54,56,58 ;96) du sous-toit et à faire que la partie (24 ;34 ;24' ;84 ;118 ;218 ;324) formant collet s'étend vers le haut à partir de la partie (22 ;32 ;22' ;82 ;116 ;216 ;322) formant bord,

iii) à fixer la partie (24,34 ;24' ;84 ;118 ;218 ;324) formant collet par rapport aux panneaux (102) structuraux de la structure de toit, et

iv) à fixer la partie (22 ;32 ;22' ;82 ;116 ;216 ;322) formant bord par rapport à un élément (102) structural de la structure du toit au moyen de moyens (130,132 ;234,236,242,244 ;315,319) de fixation, constitués d'un segment de plaque s'étendant perpendiculairement de la partie formant bord et ayant un trou traversant de réception d'un clou, d'une vis ou d'un élément (134 ;258) analogue de fixation pour fixer l'élément en forme de plaque à l'élément structural de la structure de toit ou les moyens de fixation sont constitués par des moyens de fixation en forme de crochet, destinés à s'accrocher sur l'élément structural de la structure de toit, caractérisé en ce qu'il consiste en outre au stade i) à prévoir un élément (114 ;214) de collet, destiné à être fixé dans la partie (24 ;34 ;24' ;84 ;118 ;218 ;324) formant collet ou à être fixé en entourant circonférentiellement la partie (24 ;34 ;24' ;84 ;118 ;218 ;324) formant collet pour prendre la feuille (54,56,58 ;96) du sous-toit en sandwich entre la partie (24 ;34 ;24' ;84 ;118 ;218 ;324) formant collet et l'élément (114 ;214) de collet et comprenant en outre le stade supplémentaire qui consiste :

v) à mettre l'élément (114 ;214) de collet dans la partie (24 ;34 ;24' ;84 ;118 ;218 ;324) formant collet ou, en variante, à entourer circonférentiellement la partie (24 ;34 ;24' ;84 ;118 ;218 ;324) formant collet pour prendre la feuille (54,56,58 ;96) du sous-toit en sandwich entre la partie (24 ;34 ;24' ;84 ;118 ;218 ;324) formant collet et l'élément (114 ;214) de collet.

ce que la partie (22 ;32 ;22' ;82 ;116 ;216 ;322) formant bord et la feuille (54,56,58 ;96) du sous-toit sont placées en étant mutuellement superposées, c'est-à-dire que la partie (22 ;32 ;22' ;82 ;116 ;216 ;322) formant bord est placée au-dessus et/ou en-dessous ou, en variante, en partie au-dessus et en partie en-dessous de la feuille (54,56,58 ;96) du sous-toit.

22. Procédé suivant la revendication 21, caractérisé en

Fig. 1

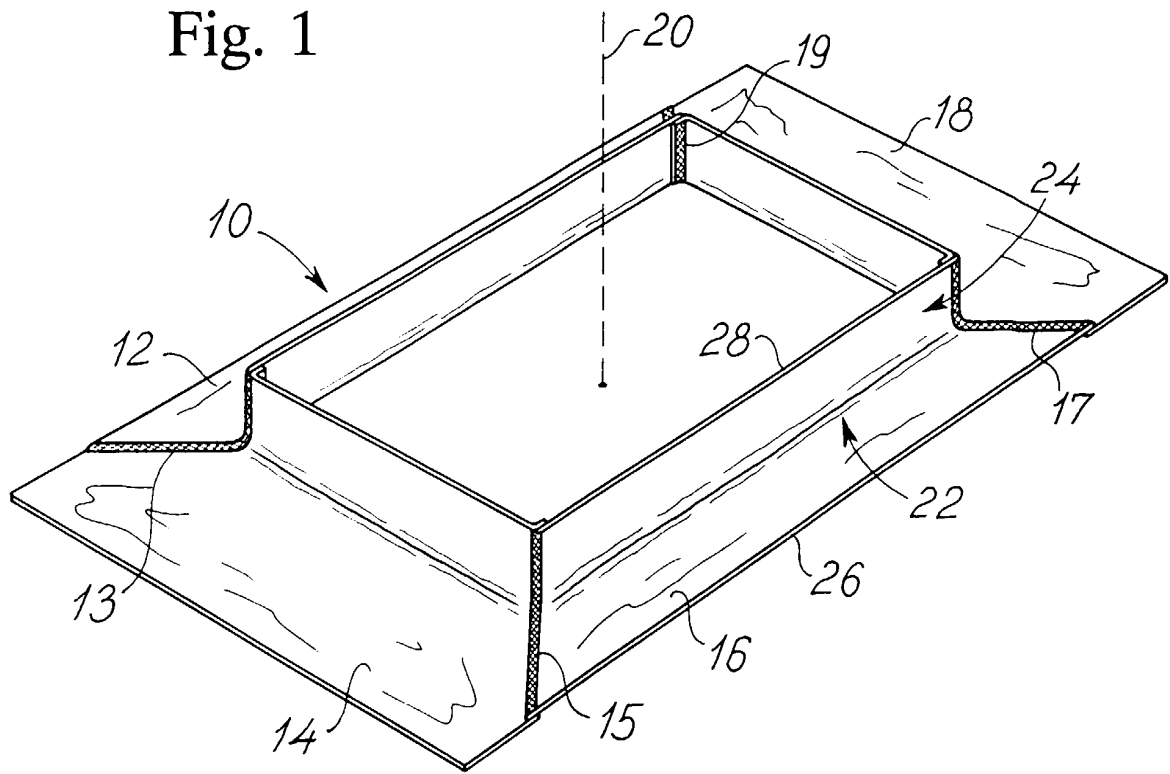

Fig. 2

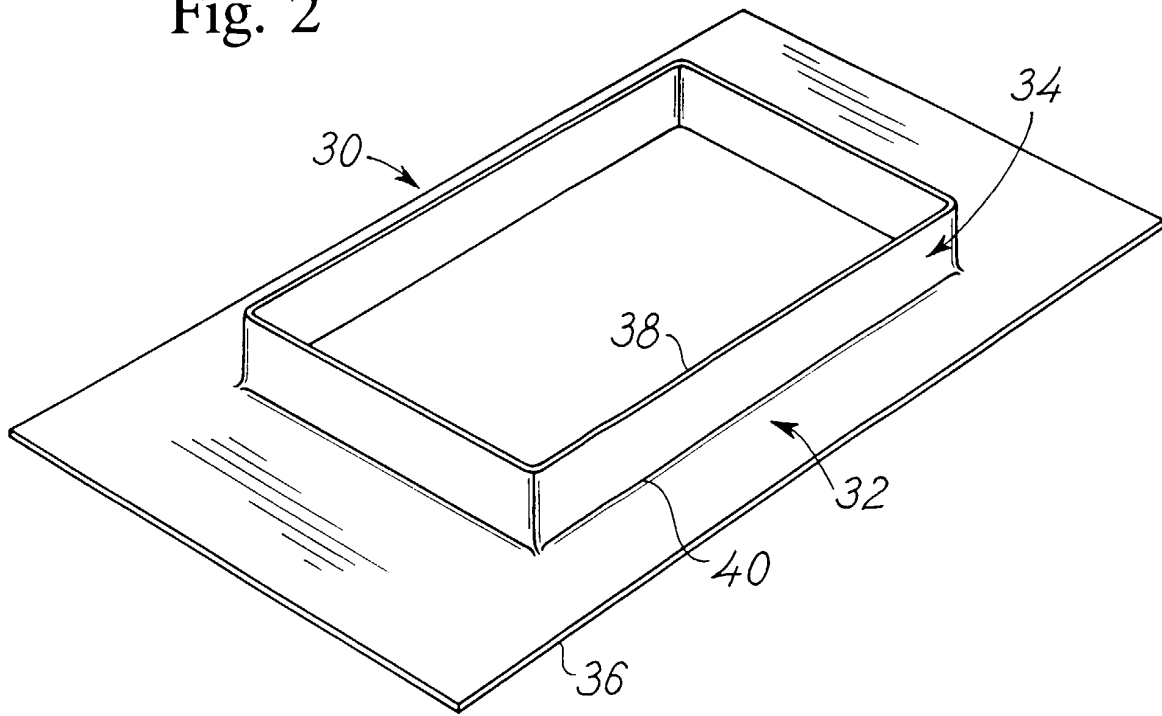

Fig. 3

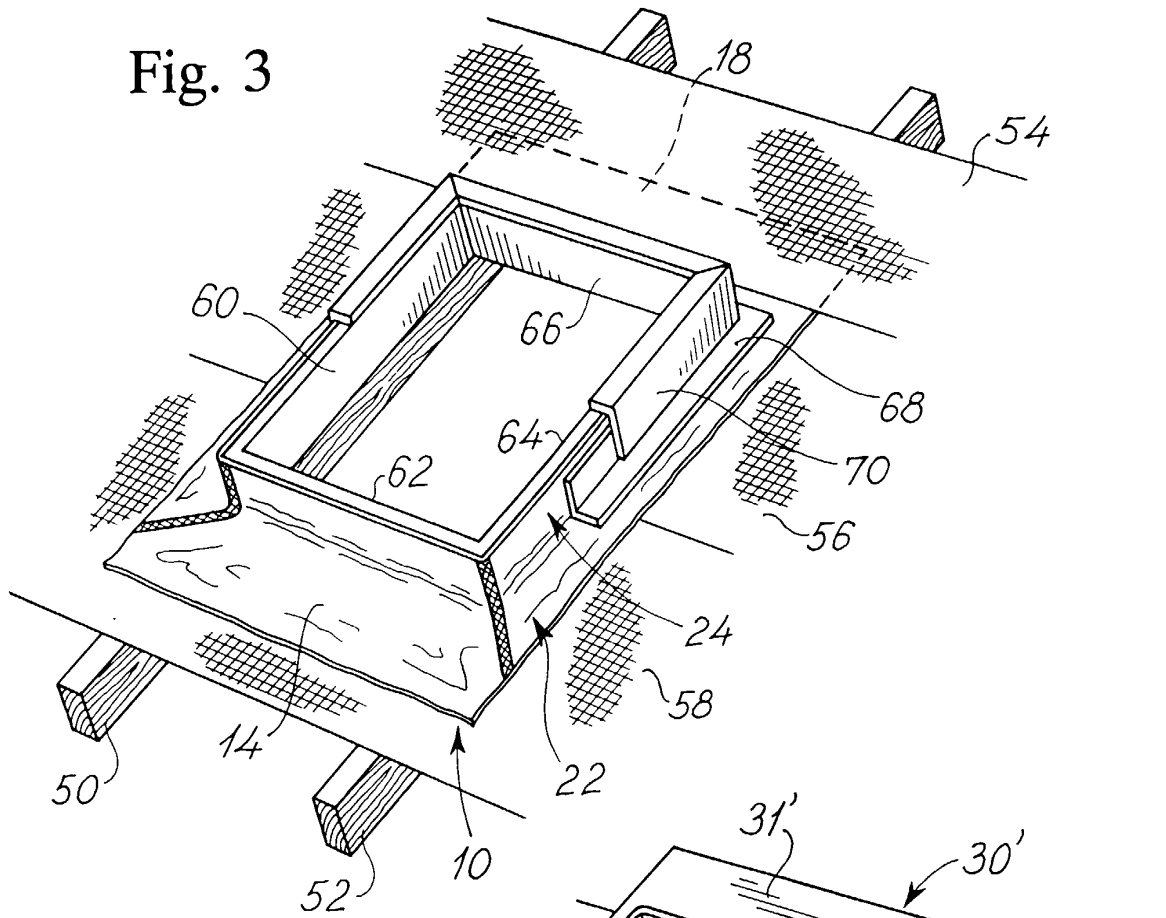
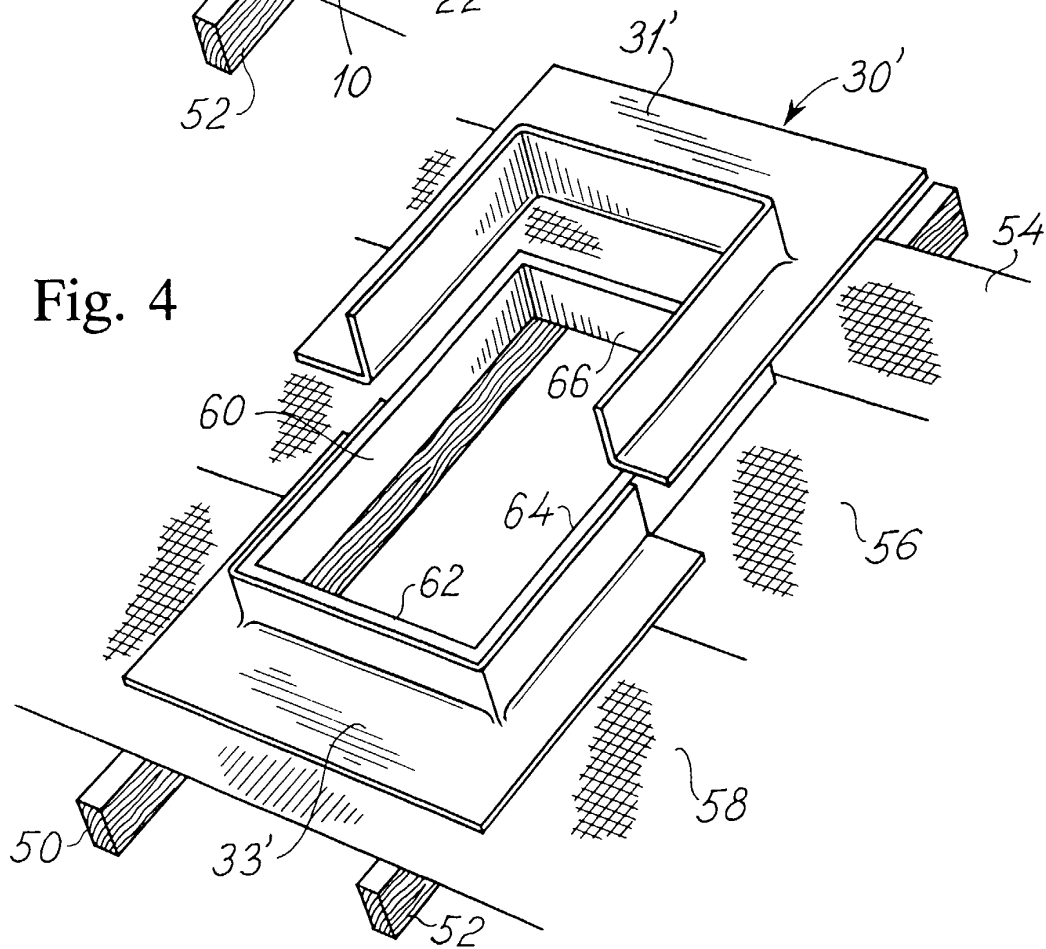

Fig. 4



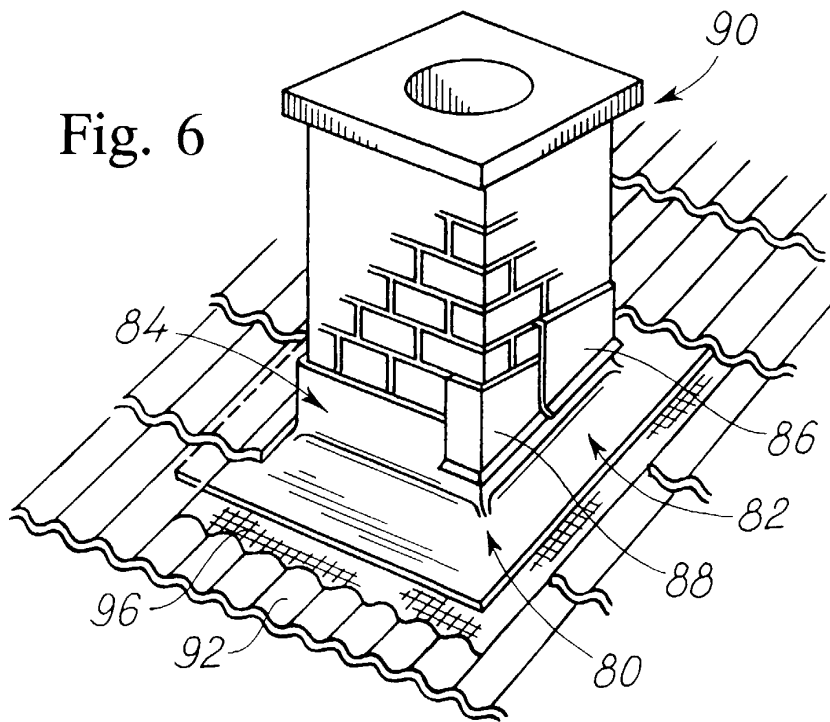
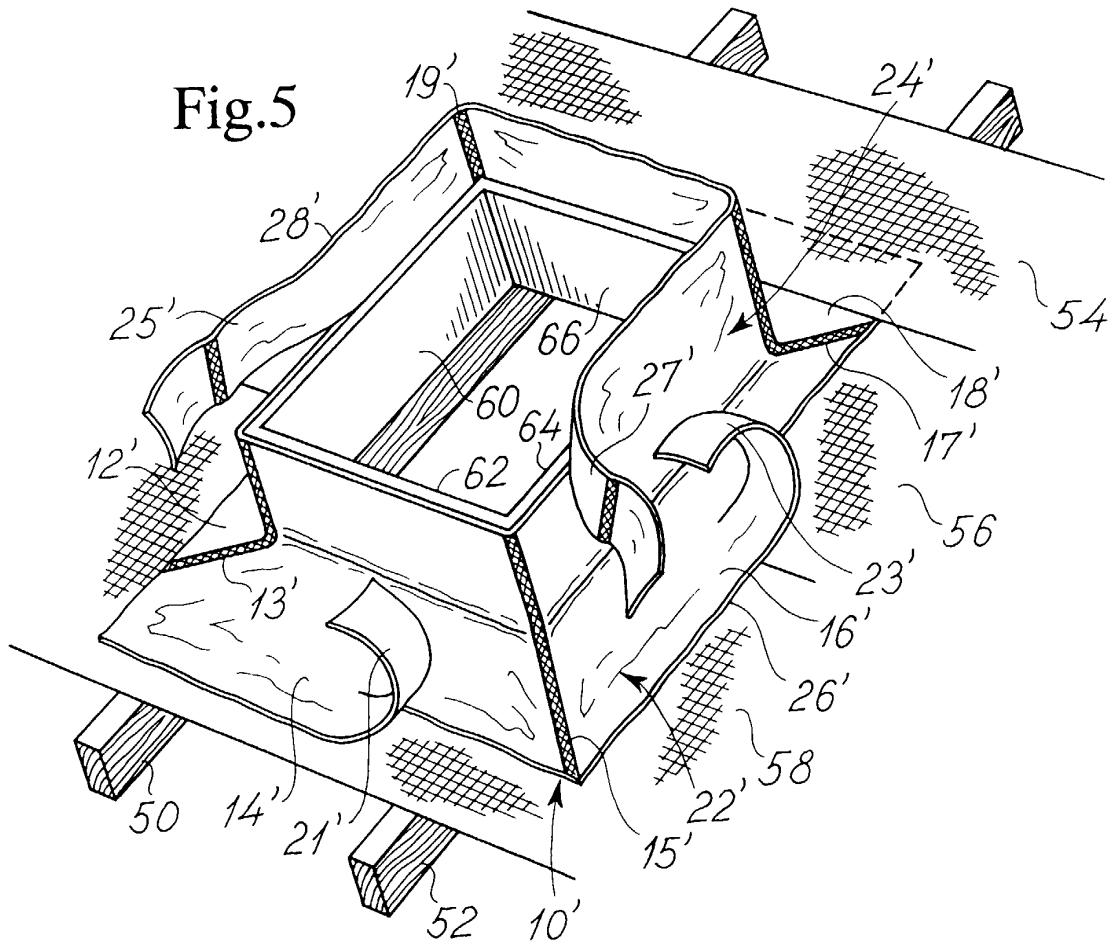

Fig. 7

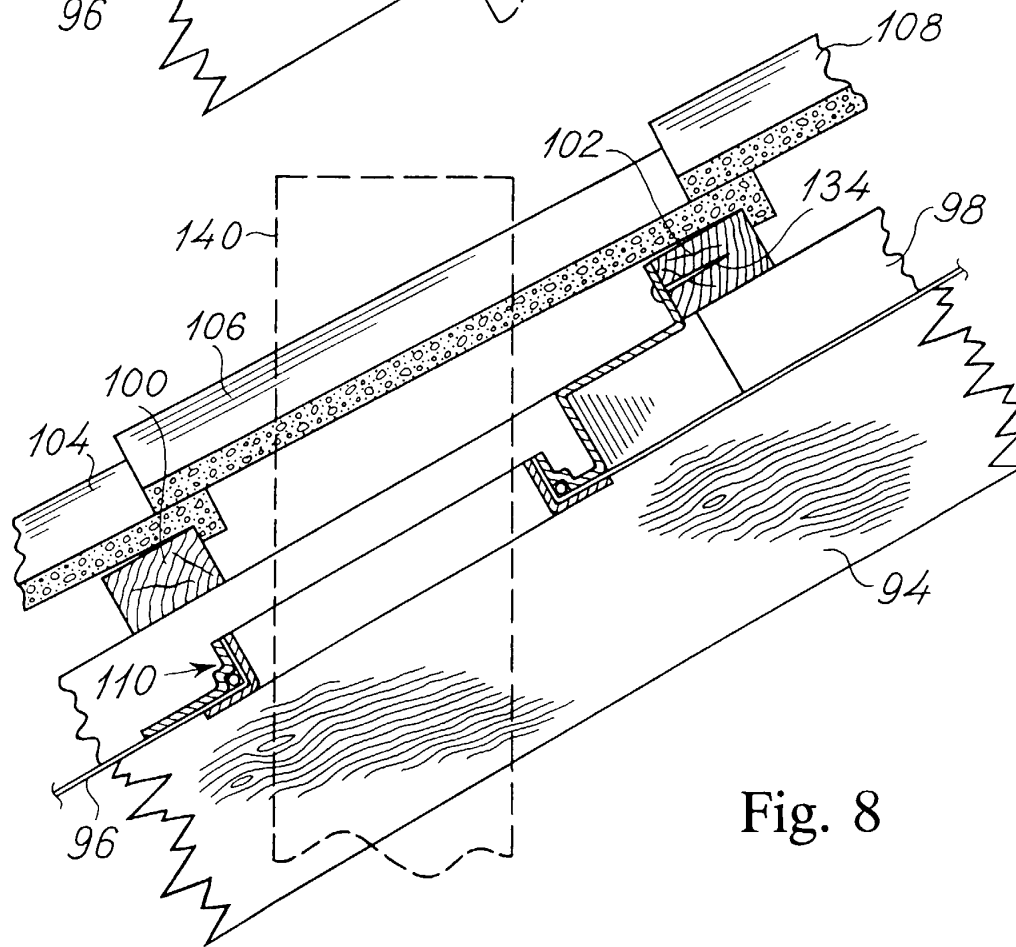
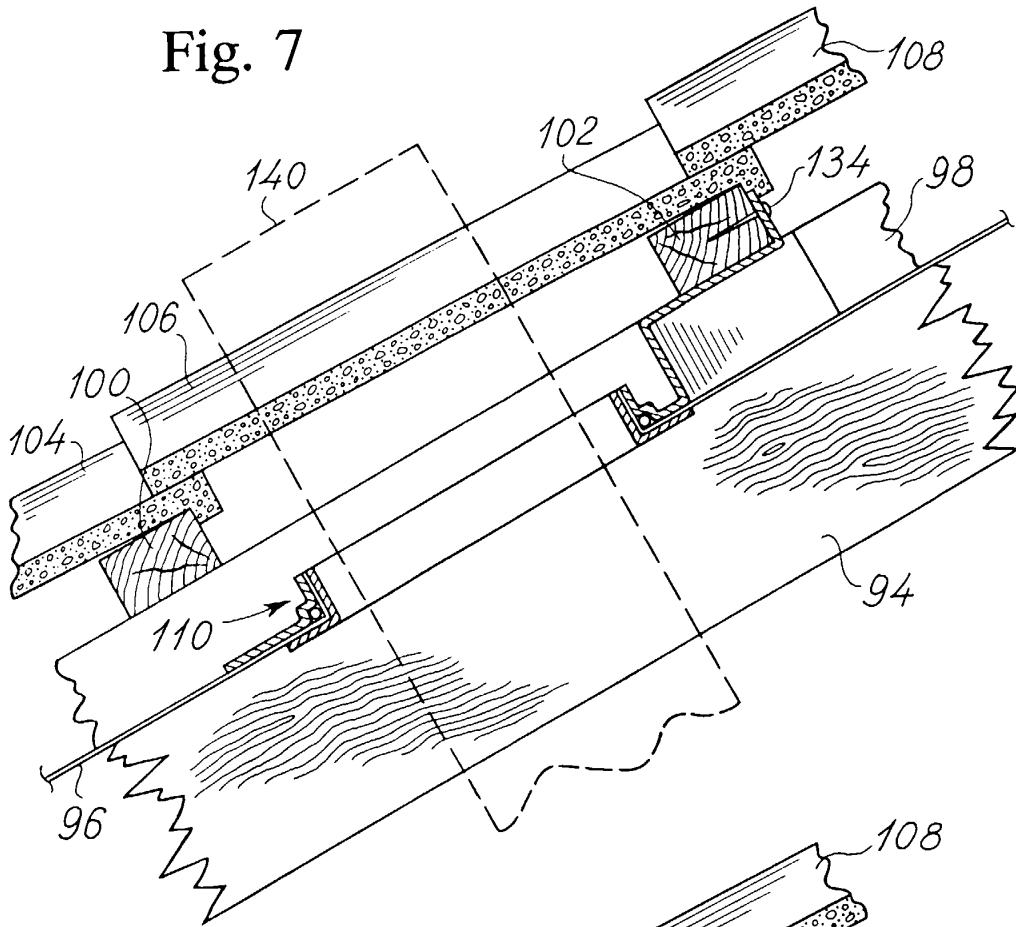
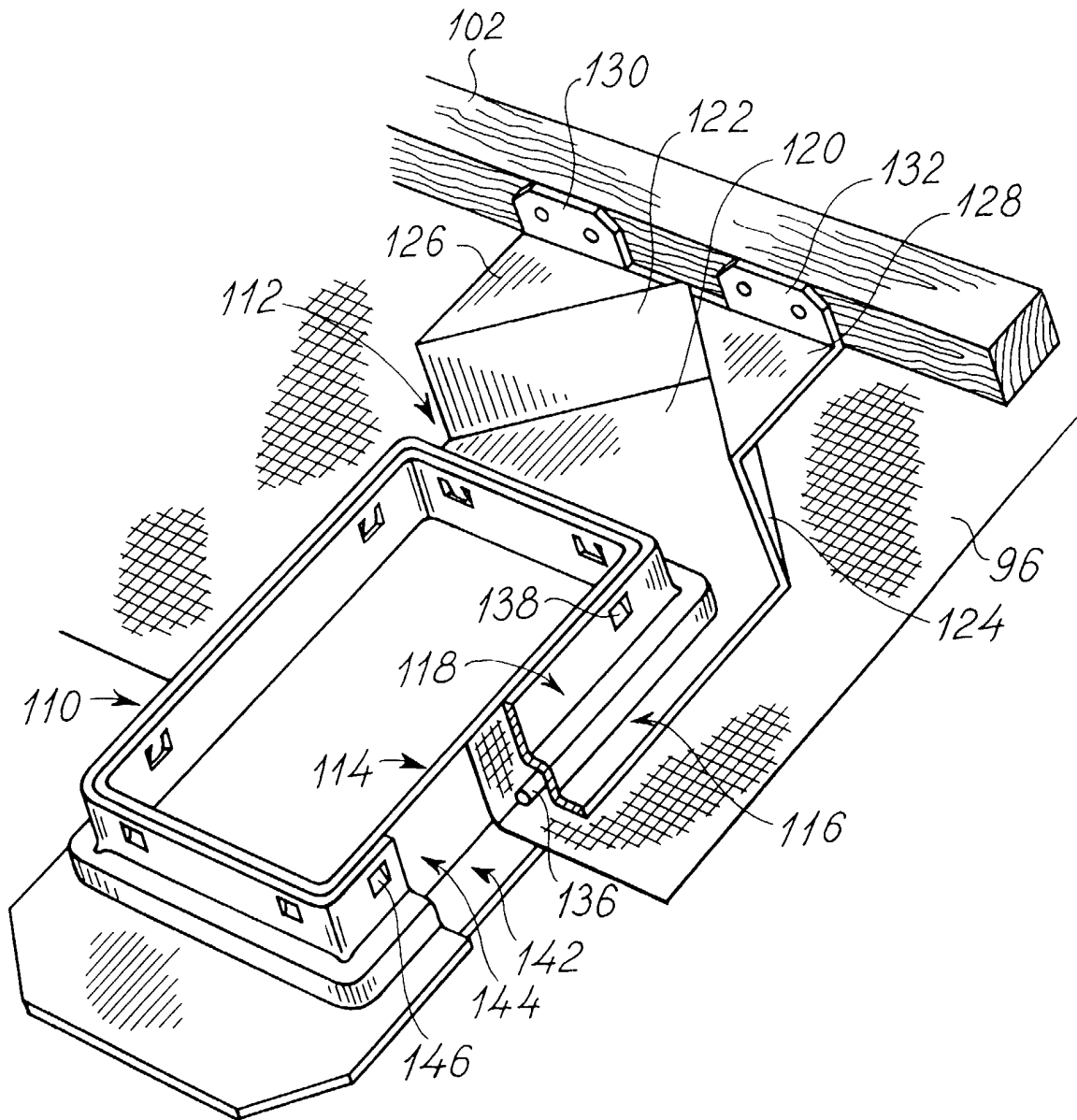

Fig. 8



Fig. 9



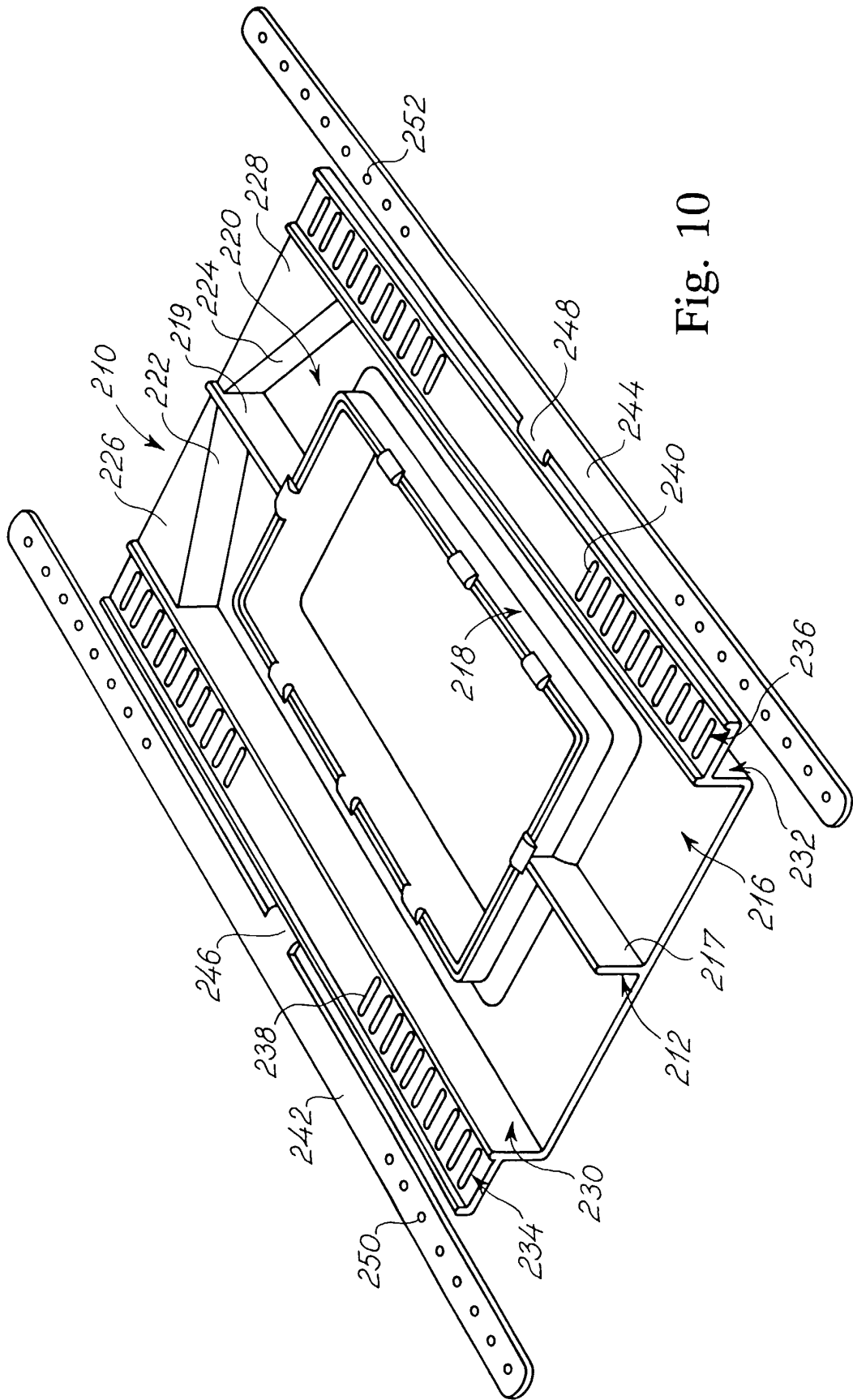

Fig. 10

Fig. 11

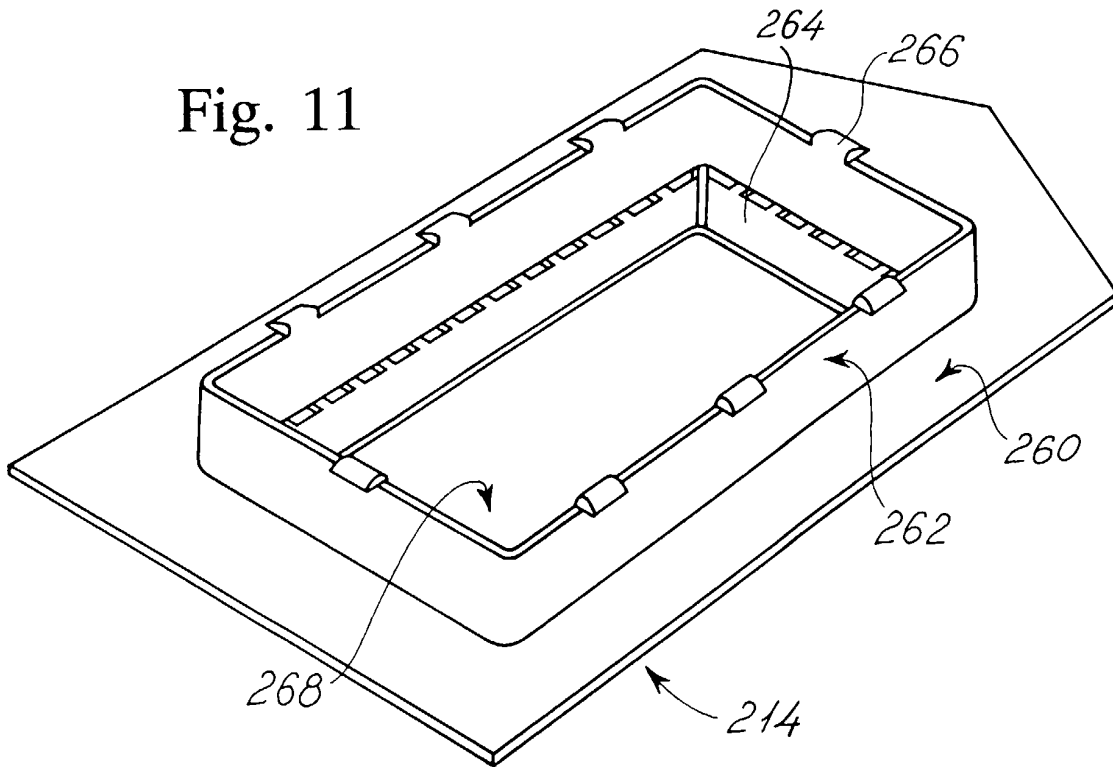
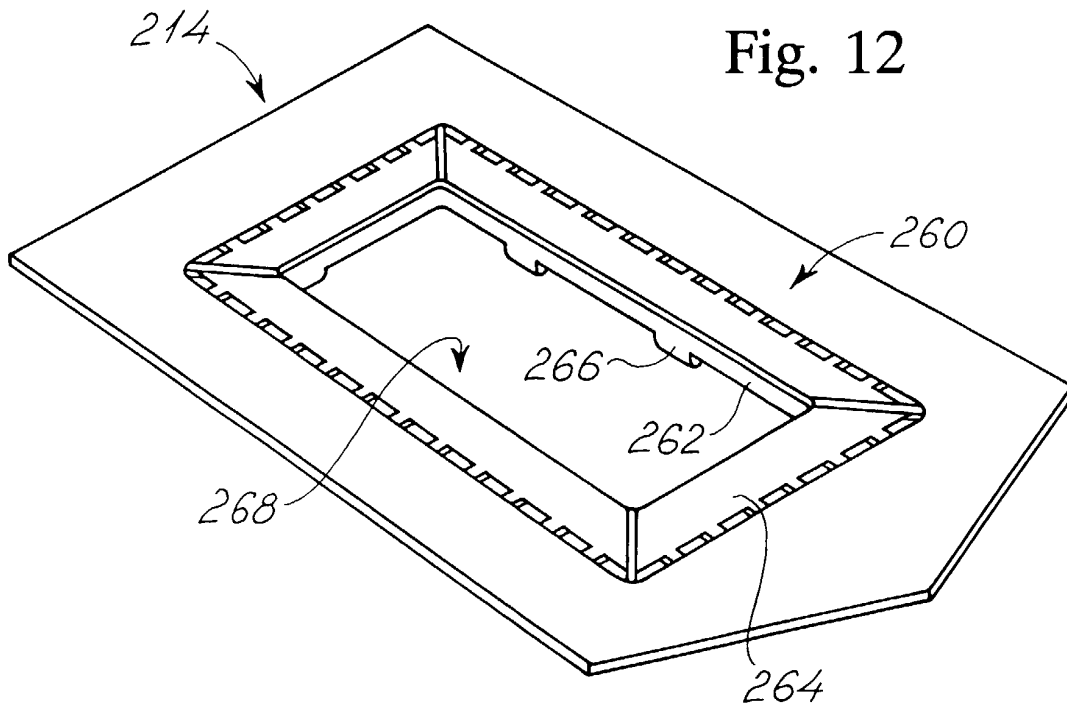

Fig. 12



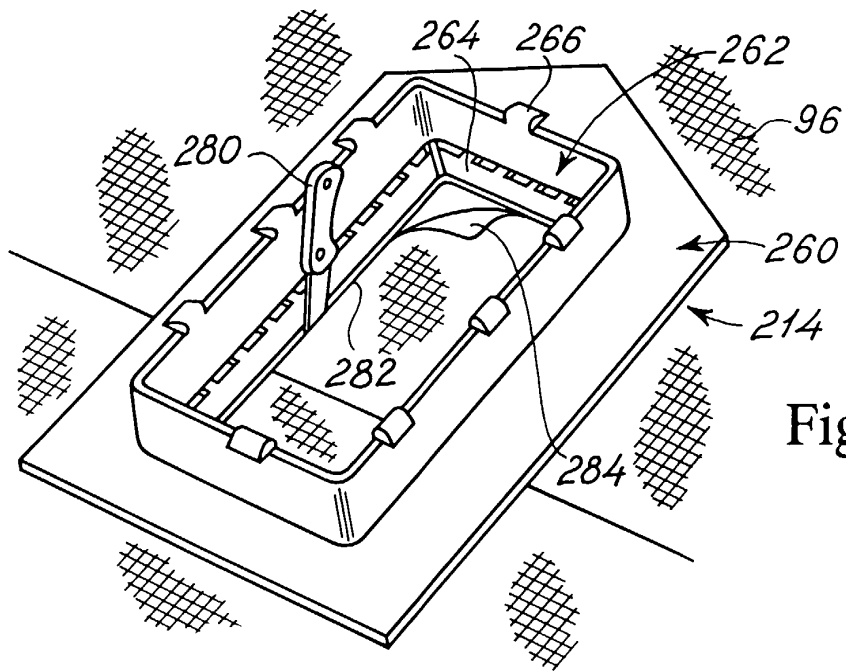

Fig. 13

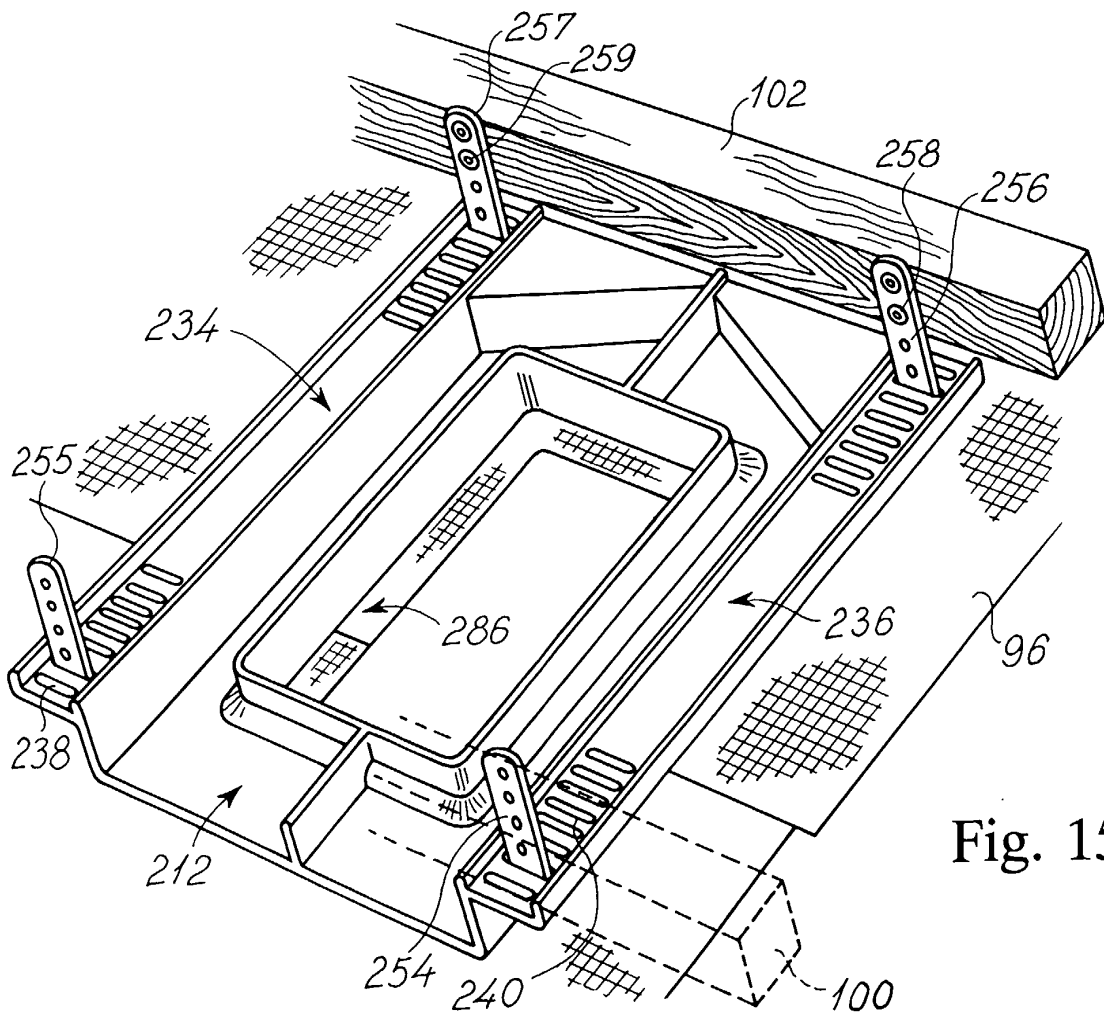

Fig. 15

Fig. 14

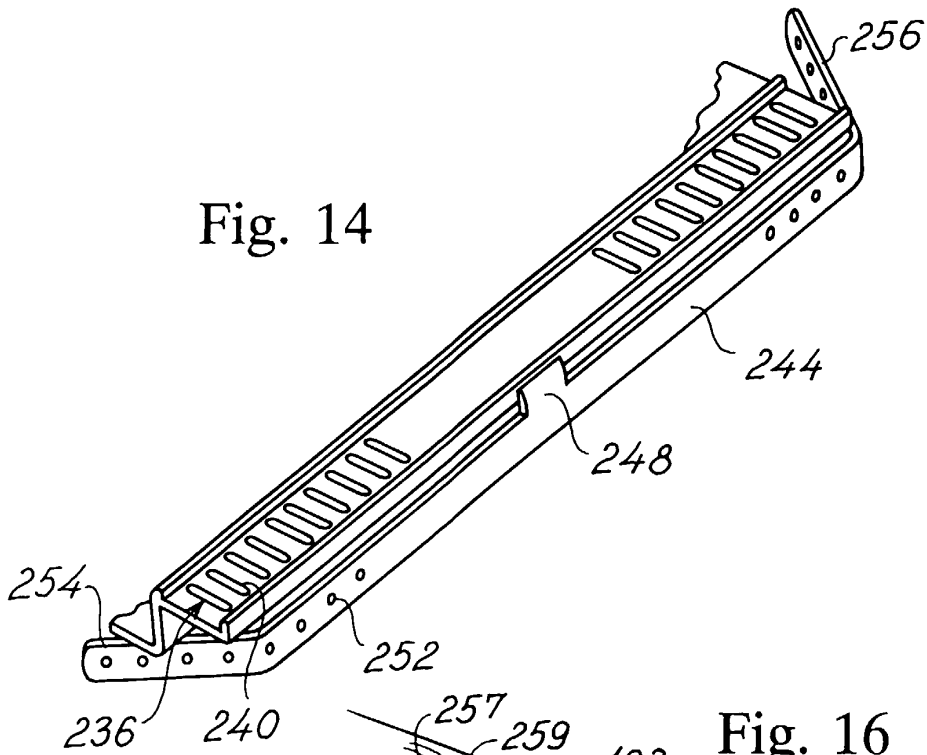
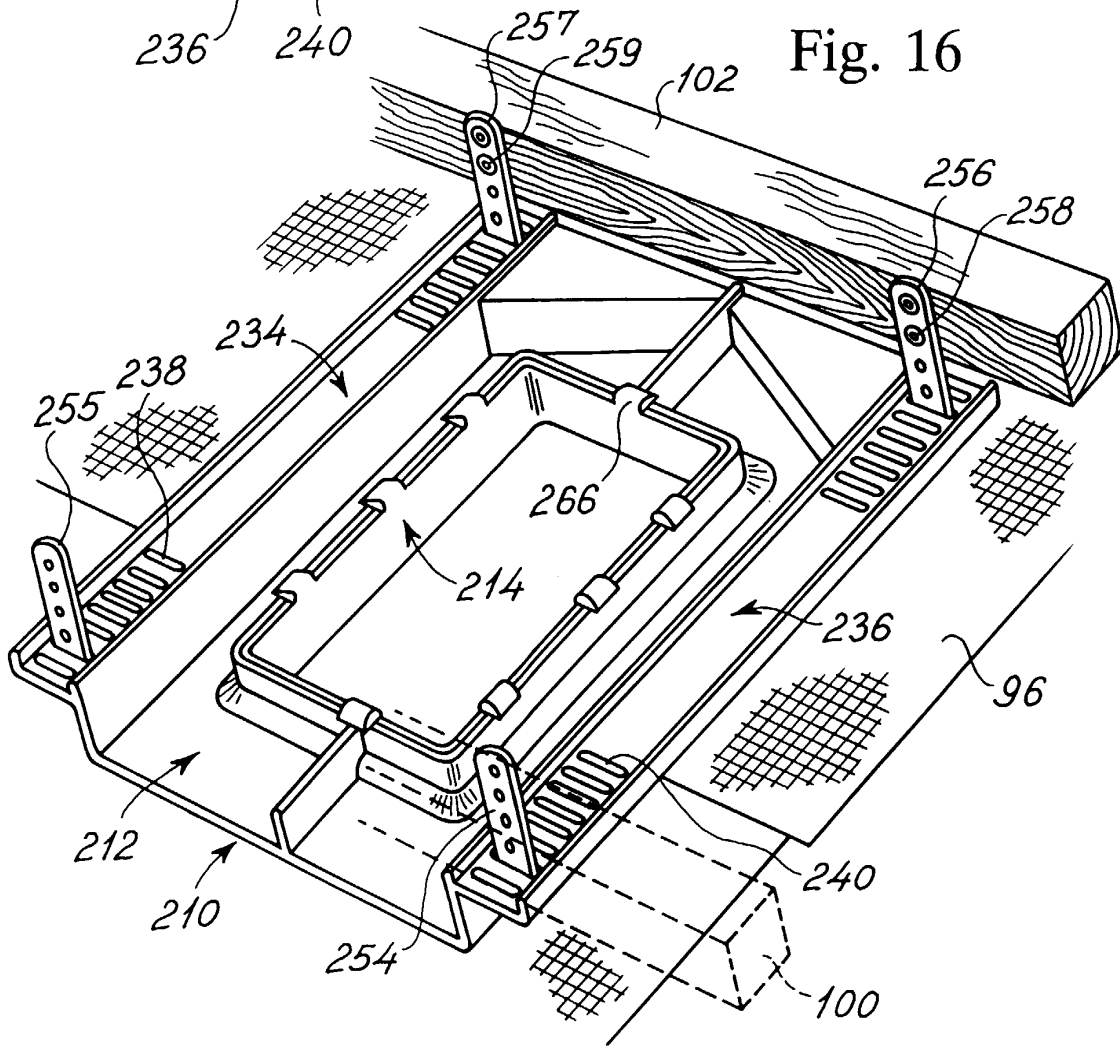

Fig. 16



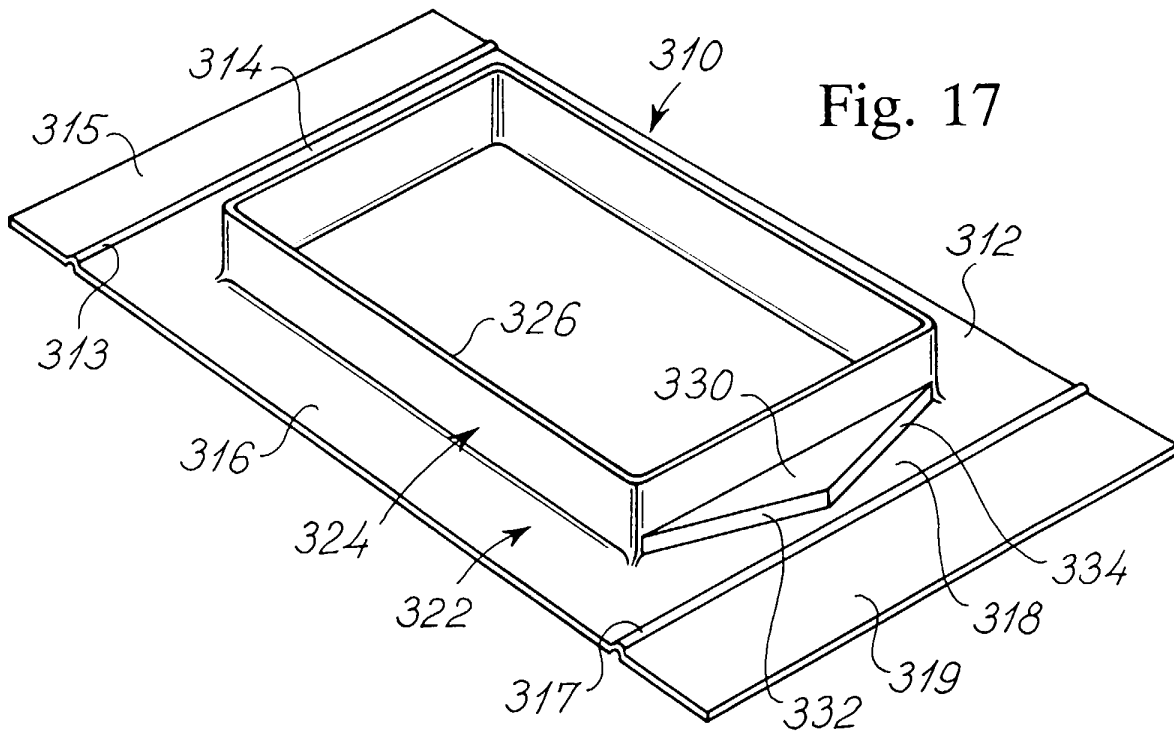

Fig. 17

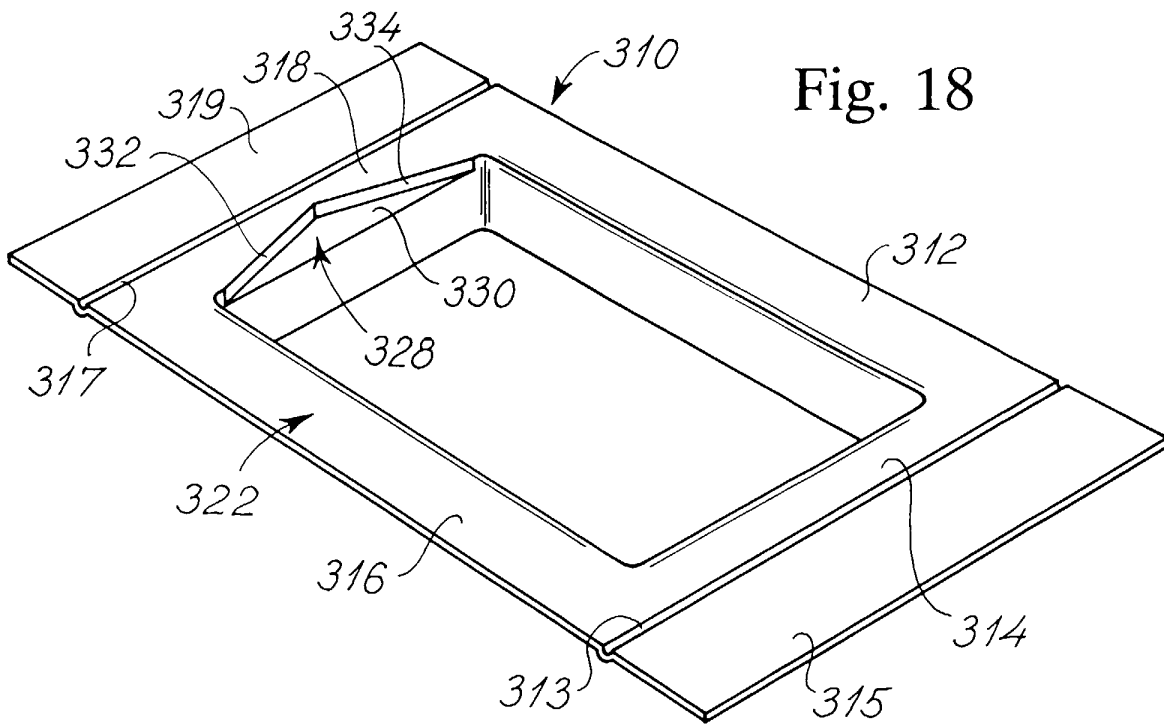

Fig. 18