



## INTERNATIONAL APPLICATION PUBLISHED UNDER THE PATENT COOPERATION TREATY (PCT)

<p>(51) International Patent Classification <sup>6</sup> : <b>D21H 23/32</b></p>	<p><b>A1</b></p>	<p>(11) International Publication Number: <b>WO 99/00548</b></p> <p>(43) International Publication Date: 7 January 1999 (07.01.99)</p>
<p>(21) International Application Number: PCT/US97/17417</p> <p>(22) International Filing Date: 26 September 1997 (26.09.97)</p> <p>(30) Priority Data: 60/051,471 30 June 1997 (30.06.97) US</p> <p>(71) Applicant (for all designated States except US): BELOIT TECHNOLOGIES, INC. [US/US]; Suite 3001, 3513 Concord Pike, Wilmington, DE 19803 (US).</p> <p>(72) Inventors; and (75) Inventors/Applicants (for US only): LAN, Xuekui [CN/US]; 3865 Valerie Road, Roscoe, IL 61073 (US). GEORGE, Brian, J. [US/US]; 13995 De La Tour Drive, Rockton, IL 61072 (US).</p> <p>(74) Agent: MATHEWS, Gerald, A.; One St. Lawrence Avenue, Beloit, WI 53511 (US).</p>		<p>(81) Designated States: AL, AM, AT, AU, AZ, BA, BB, BG, BR, BY, CA, CH, CN, CU, CZ, DE, DK, EE, ES, FI, GB, GE, GH, HU, IL, IS, JP, KE, KG, KP, KR, KZ, LC, LK, LR, LS, LT, LU, LV, MD, MG, MK, MN, MW, MX, NO, NZ, PL, PT, RO, RU, SD, SE, SG, SI, SK, SL, TJ, TM, TR, TT, UA, UG, US, UZ, VN, YU, ZW, ARIPO patent (GH, KE, LS, MW, SD, SZ, UG, ZW), Eurasian patent (AM, AZ, BY, KG, KZ, MD, RU, TJ, TM), European patent (AT, BE, CH, DE, DK, ES, FI, FR, GB, GR, IE, IT, LU, MC, NL, PT, SE), OAPI patent (BF, BJ, CF, CG, CI, CM, GA, GN, ML, MR, NE, SN, TD, TG).</p> <p><b>Published</b> With international search report.</p>

(54) Title: METHOD AND APPARATUS FOR THE HIGH SPEED APPLICATION OF COATING TO A TRAVELING PAPER WEB

## (57) Abstract

Apparatus (20, 20b) for coating a traveling paper web (w) includes a coater head (22, 22b) for applying a film of an aqueous slurry of coating material either directly to the paper web, which is supported on the surface of a rotating backing roll (14, 14b), or to the surface of a backing roll (14, 14c) which in turn applies the film to the paper web (w) which is nipped between two backing rolls. The coater head (22, 22b-d) includes an inlet (24, 24b) for receiving fresh coating material which is introduced into a mixing chamber (26, 26b). A looped flow path is established within the coater head which includes a feed channel (28, 28b) extending from the mixing chamber (26, 26b) and leading into a coating chamber (18, 18b) where one portion of the coating material proceeds in the direction of the rotating backing roll while another portion of the coating material exits the feed channel in the opposite direction over a baffle (30, 30b). The aqueous slurry of coating material near the downstream end of the coating chamber enters a recirculation channel from which it is directed through a plurality of flow metering orifices (58, 58b) back into the mixing chamber (26, 26b). This looped flow pattern operates to greatly reduce both the entrainment of air in the coating material in the application chamber and the quantity fresh coating material needed properly to coat the paper web, particularly at relatively high speeds desired. The application chamber can either include or not include a flexible blade (36, 36b). A rotating metering bar (40, 40b) is mounted on the coater head downstream of the coating chamber to meter the coating material applied to either the paper web or the backing roll.

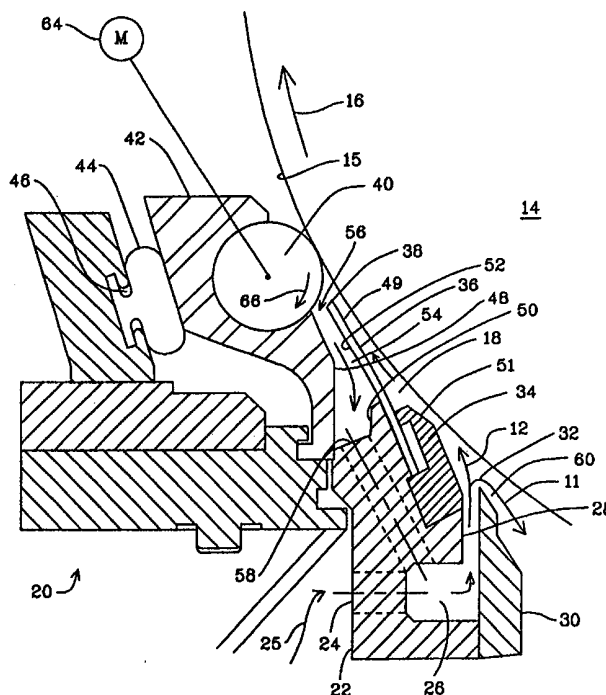

*FOR THE PURPOSES OF INFORMATION ONLY*

Codes used to identify States party to the PCT on the front pages of pamphlets publishing international applications under the PCT.

AL	Albania	ES	Spain	LS	Lesotho	SI	Slovenia
AM	Armenia	FI	Finland	LT	Lithuania	SK	Slovakia
AT	Austria	FR	France	LU	Luxembourg	SN	Senegal
AU	Australia	GA	Gabon	LV	Latvia	SZ	Swaziland
AZ	Azerbaijan	GB	United Kingdom	MC	Monaco	TD	Chad
BA	Bosnia and Herzegovina	GE	Georgia	MD	Republic of Moldova	TG	Togo
BB	Barbados	GH	Ghana	MG	Madagascar	TJ	Tajikistan
BE	Belgium	GN	Guinea	MK	The former Yugoslav Republic of Macedonia	TM	Turkmenistan
BF	Burkina Faso	GR	Greece	ML	Mali	TR	Turkey
BG	Bulgaria	HU	Hungary	MN	Mongolia	TT	Trinidad and Tobago
BJ	Benin	IE	Ireland	MR	Mauritania	UA	Ukraine
BR	Brazil	IL	Israel	MW	Malawi	UG	Uganda
BY	Belarus	IS	Iceland	MX	Mexico	US	United States of America
CA	Canada	IT	Italy	NE	Niger	UZ	Uzbekistan
CF	Central African Republic	JP	Japan	NL	Netherlands	VN	Viet Nam
CG	Congo	KE	Kenya	NO	Norway	YU	Yugoslavia
CH	Switzerland	KG	Kyrgyzstan	NZ	New Zealand	ZW	Zimbabwe
CI	Côte d'Ivoire	KP	Democratic People's Republic of Korea	PL	Poland		
CM	Cameroon	KR	Republic of Korea	PT	Portugal		
CN	China	KZ	Kazakstan	RO	Romania		
CU	Cuba	LC	Saint Lucia	RU	Russian Federation		
CZ	Czech Republic	LI	Liechtenstein	SD	Sudan		
DE	Germany	LK	Sri Lanka	SE	Sweden		
DK	Denmark	LR	Liberia	SG	Singapore		
EE	Estonia						

## PATENT APPLICATION

**METHOD AND APPARATUS FOR THE HIGH SPEED APPLICATION  
OF COATING TO A TRAVELING PAPER WEB**BACKGROUND OF THE INVENTIONField of the Invention

This invention relates to the application of coating to a traveling paper web. More specifically, this invention relates to a method and apparatus for the high speed application of a film of coating material to the paper web utilizing a looped circulation path having a web interface which moves in the direction of the traveling paper web. Still more particularly, this invention relates to a method and apparatus for the application of a film of either relatively low or high viscosity coating materials, such as sizing and pigmented coating, respectively, at relatively high speeds to a traveling paper web.

Description of the Prior Art

One of the major problems with a conventional metering size press, which applies an aqueous slurry of sizing in an almost water-like consistency, as well as a conventional coater, which applies an aqueous slurry of pigmented coating material, which can be quite viscous in its consistency, both applied as a film to a traveling paper web, is the occurrence of two phenomena known in the papermaking industry as skip-coating and non-uniform streaks on the paper web, particularly at high machine speeds. In skip-coating, the film of coating material is intermittently interrupted in the direction of paper travel, while in non-uniform coating, machine-direction streaks of coating on the paper web have different thicknesses in the cross-machine direction. Both phenomena adversely affect the coating operation, and in many cases result in an unacceptable coated paper product.

In general, the problems relating to the non-uniform application of coating material to a traveling paper web at relatively high speeds have their basis in the failure in preventing air from entering the coating process and unfavorable vortex development in the coater head as the machine speed increases. Thus, while it is relatively easy to apply coating uniformly to a paper web traveling at 800 m/minute, for example, when machine speeds increase to relatively high speeds, such as about 1800 m/minute, for example, the dynamics of the coating process, such as the frictional interface of the traveling paper web, in a coater, or of the backing roll surface, for size press configuration, with ambient air, as well as small under- and over-atmospheric pressures created by the dynamics of the flowing coating material, induce entrained air within the aqueous slurry of coating material, which promotes the aforementioned problems.

In existing coating processes, particularly for the application of a film of relatively low viscosity, water-like sizing to printing grade types of paper, the aqueous slurry of coating material supplied to the channel or chamber exposed to the surface of the traveling paper web on a coater, or the backing roll surface, in the case of a metering size press, either flows against the paper web and out of the coater head at the downstream end, or is divided into two portions, with one portion flowing downstream and the other portion flowing upstream over a baffle and out of the coater head.

The problem with these arrangements is that neither of them works well at relatively high speeds, such as about 1800 m/minute, or greater. In the first case, because of the development of the unfavorable vortex, air is readily brought into the coating chamber by its frictional engagement with the surface of the traveling paper web (coater) or the backing roll for a metering size press. In the second case, due to the division of the flow of

the coating material into upstream-directed and downstream-directed portions, in order to prevent entrainment of air traveling with the paper web or backing roll surface into the coating chamber, the flow of the portion of coating material upstream over the baffle must be sufficiently great such that there is then either an insufficient supply of coating material in the portion supplied to the coating chamber to properly coat the paper web traveling at the relatively high speed, or there is sufficient coating material to coat the paper web, but such coating is deleteriously effected due to insufficient coating in the portion flowing upstream over the baffle wall to prevent air from entering the coating chamber to be entrained in the coating material.

Some of these problems can be mitigated by either utilizing a more powerful pump, or a pump with a higher capacity for supply more coating material to the coater head. However, paper manufacturers are reluctant to incur the extra capital and operating costs associated with these alternatives. They prefer to operate with a minimum amount of coating material.

#### SUMMARY OF THE INVENTION

The deficiencies and limitations of existing coating apparatus for coating a traveling paper web with a film of coating material, including metering size presses and coaters for applying pigmented coating materials, both of which utilize coating applied to the traveling paper web, particularly at relatively high speeds, are obviated by this invention. In this invention, a flow loop is established within the coater head where a fresh supply of an aqueous slurry of coating material is brought into the coater head and is directed into a mixing chamber. In a preferred embodiment, a plurality of flow-metering orifices also link a recirculation channel within the coater head in fluid communication with the mixing chamber. A feed channel is in

fluid communication with the mixing chamber, downstream thereof, for receiving the aqueous slurry of coating material from the mixing chamber. The feed channel leads toward the backing roll.

Near the end of the feed channel, the aqueous slurry is divided into two portions comprising, in a preferred embodiment, a major portion which travels downstream into a coating chamber and a minor portion which is urged by the hydraulic pressure in the feed channel to flow upstream over the edge of a baffle against the movement of the paper web traveling into the coater head.

The flow of the aqueous slurry in the coating chamber may utilize a blade, which preferably is relatively flexible and which forms the coating chamber, in a preferred embodiment, into a converging channel extending downstream in the machine direction. Alternatively, the coating chamber may not utilize such a flexible blade. In the case where no flexible blade is utilized, the coating chamber is defined between a relatively rigid stabilizer surface of the coater head extending downstream from the feed channel, and the surface of the backing roll. In operation of the coater embodiment, of course, the backing roll surface is covered by the paper web supported against the rotating backing roll. Therefore, for purposes of defining the side of the coating chamber against the backing roll, this side/surface is intended to include the backing roll with or without the paper web supported by the backing roll.

Whether or not a blade is used, a recirculation channel is formed in the coater head either on the side of the flexible blade facing away from the backing roll or, in the case where no blade is utilized, the recirculation channel is more distantly spaced radially from the outer surface of the backing roll (metering size press) embodiment, or from the paper web over

the backing roll (coater embodiment) and perhaps even partially located somewhat beneath the relatively rigid stabilizer surface. The recirculation channel is maintained in fluid communication with the mixing chamber preferably through a plurality of flow metering orifices.

Thus, a looped flow path is established for the aqueous slurry to flow in the same direction as the direction of travel of the paper web and/or the rotation of the backing roll which, in the coater embodiment, supports the paper web on one side of the coating chamber. This arrangement utilizing recycled coating from the recirculation channel facilitates flow through the coating chamber without requiring an increased flow of fresh coating material into the coater head, particularly in an amount commensurate with the increased speed of paper web travel. A serendipity effect of this arrangement is that the flow of the aqueous slurry in the upstream direction over the baffle can simultaneously be maintained at a high enough volume sufficient to prevent the flow of air traveling with the surface of the backing roll (metering press embodiment) or of the uncoated paper web (coater embodiment) from entering the coating chamber, or at least entering in an amount sufficient to deleteriously affect the condition of the coating operation as it pertains to skip coating and non-uniform streaks in the coated paper product.

Downstream of the coating chamber is a metering rod which is held in a rod holder in biased nipping engagement against backing roll surface, or the surface of the paper web supported over the surface of the backing roll. In a preferred embodiment, this round rod is rotated in a direction such that its surface moves counter to the direction of the backing roll surface/traveling paper web. This smooths, or meters, the coating on the outer surface of either the backing roll or the paper web traveling through the application chamber as well as helps create some hydraulic over-

pressure in the recirculation channel for urging coating material passing out of the coating chamber into the recirculation chamber and through the flow-metering orifices for recirculation.

It is this recirculation which permits the coating function to be effected at relatively higher speeds without requiring larger pumps to supply the aqueous slurry of coating material to the coater head, or a greater supply of the aqueous slurry of coating material, or both, in order to provide the desired results.

The invention can be used to improve the coating quality and increase the coating speed in both coater and size press operations. In coater operations, the coating is directly metered onto the paper web wrapping the backing roll. The invention will lead to a uniform coating application on the paper web without skip coating at high speed. In size press operations, the coating is metered onto the backing roll. The invention will ensure a uniform coating film on the backing roll without skip coating at high speed, which film is eventually transferred into a high quality coating on the paper web.

Accordingly, it is an object of this invention to provide an improved coating apparatus for coating a paper web traveling at relatively high speeds.

A feature of this invention is the provision of coating apparatus having a continuous, looped flow path within a coater head for recirculating a portion of the coating within the coater head.



Another feature of this invention is the provision of coating apparatus wherein the recirculation of a portion of the coating to be combined with fresh coating entering the inlet of a coater head.

Still another feature of this invention is the provision of coating apparatus which utilizes recirculation of a first portion of the coating, and utilizes a second portion of the coating to effectively seal a traveling paper web from air being entrained in the coating.

These, and other objects, features and advantages of this invention will become apparent to those skilled in the art upon reading the description of the invention and preferred embodiments in conjunction with the attached drawings.

#### BRIEF DESCRIPTION OF THE DRAWINGS

Fig. 1 is a side elevational view in section, shown somewhat schematically, of a known configuration for a metering size press type of coater.

Fig. 2 shows streamline patterns for the conventional metering size press of the type shown in Fig. 1.

Fig. 3 is a side elevational view in section, shown somewhat schematically, of a preferred embodiment of the coating apparatus of this invention which utilizes a blade in the coating chamber.

Fig. 4 is a view of the streamline patterns of the coating flowing through the coating apparatus shown in Fig. 3.

Fig. 4A is a view of the streamline patterns of the coating flowing through the coating apparatus similar to that shown in Fig. 3, but without the blade

Fig. 5 is a side elevational view of another embodiment of the metering size press, or coater, of this invention, shown somewhat

schematically, and similar to the embodiment shown in Fig. 3, and which does not utilize a blade.

Fig. 6 is a side elevational view in section of the coater embodiment of this invention, shown somewhat schematically, where coating is applied directly to the traveling paper web.

Fig. 6A is a side elevational view of the metering size press embodiment of this invention where the coating is applied directly to the surface of a backing roll and two backing rolls are nipped over the traveling paper web.

#### DESCRIPTION OF THE PREFERRED EMBODIMENT

In this invention, the term "coating" is used in a broad sense to denote an aqueous slurry of coating material, which coating material might comprise sizing, such as used in a size press, or pigmented coating, such as used in a conventional coater. An aqueous slurry of sizing is quite non-viscous and flows substantially like water. On the other hand, an aqueous slurry of pigmented coating material, which pigment might comprise, for example, titanium dioxide or calcium carbonate, is very viscous and does not readily flow at all.

Similarly, the term "coater" is used herein to denote all coaters, regardless of whether they might be more specifically known as size presses or another specific type or configuration of coater.

In the various embodiments, including the known embodiment shown in Fig. 1, the same numbers will be used to identify corresponding or similar elements, but with alphabetical suffixes to distinguish between specific elements. Similarly, the same element which is used twice in the same embodiment is designated with a prime mark in the second occurrence.

Referring to Fig. 1, in a conventional, known type of metering size press, the flow of coating into the coater head shown by the flow arrow designated **10a** is divided into upstream-flowing and downstream-flowing portions **11a**, **12a**, respectively. The direction of rotation of backing roll **14a** is shown by arrow **16a**. This division of coating flow is so significant that the portion of the coating flowing upstream against the direction of web travel on the surface of the backing roll is insufficient to prevent air from entering the coating chamber **18a**. Therefore, the coating apparatus is speed-limited because even at a relatively low speed, such as about 1,000 m/minute, the portion of the coating flowing upstream is insufficient to prevent air from entering the coating chamber. This phenomenon is depicted graphically by the stream-flow lines **19** shown in Fig. 2.

In coater/size press terminology, "downstream" is the direction of travel of the paper web or the direction of rotation of the backing roll.

Referring to Fig. 3, in this invention, coating apparatus, designated generally by the numeral **20**, includes a coater head **22**. An inlet **24** is formed in the coater head for admitting fresh coating **25** from an outside source, not shown, for preparing a new, or fresh, supply of coating to be supplied to the coater head. The inlet, which preferably comprises a plurality of parallel holes aligned in the cross-machine direction, leads into a mixing chamber **26**. A feed channel **28** leads out of the mixing chamber and extends upwardly, as shown in Fig. 3, toward the surface **15** of the backing roll **14**.

Since the apparatus shown in Fig. 3 (and in Fig. 5) is generic to that used in both a metering size press and a coater embodiment, the coater head may either bear directly against the surface of the backing roll (size press embodiment) or against a paper web (not shown in Fig. 3) supported

on the surface of the backing roll (coater embodiment). A baffle **30** having an edge **32** forms an upstream wall of the feed channel with the edge disposed in closely-spaced adjacency with the surface of the paper web over the backing roll to form a gap between them.

The feed channel **28** is in fluid communication with a coating chamber **18** which extends downstream in the coater head from the downstream opening of the feed channel. The coating chamber is open in the direction facing the backing roll (metering size press embodiment) or the paper web supported on the surface of the backing roll **14** (coater embodiment). In other words, when the coater apparatus shown in Figs. 3 and 5 is used in a coater, the coater head **22d** is in the embodiment shown in Fig. 6A. When the coater apparatus shown in Figs. 3 and 5 is used in a metering size press embodiment, the coater heads **22c**, **22c'** are in the embodiment shown in Fig. 6.

In this description, it is understood that the various structural elements, such as feed channel edge **32**, feed channel **28**, mixing chamber **26**, as well as other items of the coating apparatus, extend in the cross-machine direction, which is perpendicular to the plane of the paper on which the figures are shown, longitudinally for the effective width of the apparatus. Thus, there are edge walls on either end of the coating apparatus, but such end walls are not shown for purposes of clarity in viewing the figures. The figures are also shown in cross-section for the same reasons of clarity.

Still referring to Fig. 3, a flow stabilizer **34** is mounted within the coater head and, in this preferred embodiment, a blade **36** extends downstream from its clamped mounting in the flow stabilizer with at least a portion of the blade's downstream-extending length being arrayed to make

the coating chamber **18** substantially converging in the downstream direction. The blade is preferably flexible and has a distal end **38** which effectively defines the end of the coating chamber **18**. The coater chamber is thus effectively defined by the surfaces of the flow stabilizer and blade surface **49** facing the backing roll and the surface of the backing roll (and the web supported on the backing roll) facing the blade.

Near the downstream end of the blade, a metering rod **40** is rotatably mounted in a rod holder **42**, which in turn, is mounted in the coater head by a suitable means, such as being clamped by the structure as shown in Fig. 3. An inflatable tube **44**, which extends longitudinally in the cross-machine direction, is also mounted into the coating apparatus by suitable means, such as being press-fit into a slot **46** as shown in Fig. 3, and is operable by being attached to a source of compressed air (not shown) to bias the flexible (i.e., plastic), or flexibly mounted, metering rod holder to press the metering rod into nipping engagement with the backing roll **14**.

A surface **48** of the metering rod holder and surfaces **50** of the coater head **26**, and **52** of the blade facing away from the backing roll define a recirculation channel **54** which collects coating passing over the distal end of the blade as designated by arrow **56**. At the other, lower, end of the recirculation chamber, referring still to the embodiment shown in Fig. 3, a plurality of flow-metering orifices **58** are formed in the coater head. These flow-metering orifices are aligned parallel with one another in the cross-machine direction. They extend longitudinally between the recirculation channel **54** and the mixing chamber **26**.

In the embodiment shown in Fig. 5, the apparatus is essentially the same as that shown in Fig. 3, except that no blade **36** is utilized. In this

embodiment, the outer, or top, surface **51b** of the flow stabilizer **34b** forms the side of the coating chamber **18b** which is not formed by the surface of the backing roll. In other words, the top of the blade clamp comprises the flow stabilizer and its surface which defines one side of the coating chamber. Since the outer surface of the flow stabilizer is relatively more distantly spaced from the backing roll, and since there is no blade forming any convergence in the coating chamber downstream from where the blade would otherwise be clamped, the coating chamber is shorter in length and greater in height, as measured radially outwardly from the surface of the backing roll, all such that a greater quantity of coating can be accommodated in the coating chamber so that a greater flow rate of coating can be attained.

Thus, in the embodiment shown in Fig. 3 utilizing a blade, faster speeds can be accommodated at a lower flow rate. In the embodiment shown in Fig. 5, higher speeds can be accommodated with a higher coating flow rate.

With reference to Figs 4 and 4A, the stream flow lines **21** are substantially smooth and straight with essentially small curves. This is due in large part to the continuous, looped flow of the coating permitted and augmented by the recirculation chamber. The flow of fresh coating into the inlet and mixing chamber is not necessary at high volumes and pressures in order to sustain the coating process at high machine speeds. This also operates to reduce fluctuations and extremes in both the flow and hydraulic pressure of the coating within the coating chamber. Coating is essentially recirculated through the mixing chamber, feed channel, coating chamber, and recirculation channel until it is eventually applied to the traveling paper web. Because of the favorable recirculation flow pattern, there is less opportunity for flow instability and air entrainment to occur in the coater

head. Also, due to the recirculation feature utilized in conjunction with the separate mixing chamber, less fresh coating, and the pumping capacity to supply it, is required in the coating.

Figs. 6 and 6A illustrate the basic metering size press and coater embodiments, respectively,

In the metering size press configuration (MSP), two coater heads **22c, 22c'**, of the type shown in more detail in Figs. 3 and 5, are operatively disposed against the backing rolls **14c, 14c'** which are nipped against the web **W** traveling through the nip **N**. The coater heads apply a coating film onto the surfaces of the backing rolls. This film is metered by the counter-rotating (relative to their respective backing rolls) metering rods **40c, 40c'**. The smooth, even film is then applied to both sides of the traveling web **W** simultaneously in the nip **N**.

In the coating arrangement shown in Fig. 6A, the coater head **22d** applies to coating onto one side of the web **W** which is carried and supported by the surface of backing roll **14d**.

In operation, fresh coating is introduced under pressure into the inlet **24** in the coater head to be in turn introduced into the mixing chamber **26**. This fresh coating is mixed with a supply of recirculated coating which is directed into the mixing chamber via the plurality of orifices **58** extending between the recirculation channel and the mixing chamber. The combined mixture of fresh and recirculated coating is then directed into the feed channel where it is divided into portions **11, 12** near the end of the feed channel. The inlet **24**, mixing chamber **26**, and feed channel **28** are separate and distinct. A first portion **12**, which preferably comprises a major portion, is directed downstream into the coating chamber. A second

portion **11**, preferably comprising a minor portion is directed over the edge of the baffle into the gap **60** to form an effective seal against air being drawn into the coating chamber to be entrained in the coating by means of the frictional engagement of ambient air by the surface of the backing roll, in the metering size press embodiment, or by the paper web, in the coater embodiment, traveling at high speed into the coater head.

In the metering size press embodiment, shown in Fig. 6, each coater head **22c**, **22c'** has a film of coating metered onto the surface of a pair of backing rolls **14d**, **14d'** nipped over a traveling paper web *W*. The coating film is first metered directly onto the surfaces of the backing rolls by the counter-rotating metering rods **40c**, **40c'**. Then both sides of the web *W* are coated as the web passes through the nip *N* between the backing rolls.

In the coater embodiment, shown in Fig. 6A, the coating process occurs in the coating chamber as the outer surface of the web over the backing roll is brought into pressurized contact with the coating such that a continuous, uniform film of coating is deposited on the traveling paper web as the coating in the coating chamber flows in the same direction as the direction of rotation of the backing roll **16** and also the paper web.

Coating which is not applied to the paper web passes either beyond the distal edge **38** of the blade, or beyond the end **50** of the portion of the coater head which comprises the downstream extension of the flow stabilizer. In either case, the coating passes into the recirculation chamber **54** for entry into the orifices **58** for recirculation into the mixing chamber. This recirculation flow into the mixing chamber does not affect the flow of fresh coating into the inlet **24**. Thus, a continuous, loop of coating flow is established within the coater head. The supply of fresh coating therefore



needs only to meet the needs of coating which is actually applied to the surfaces of the traveling paper web and which flows over the baffle.

Downstream of the coating chamber, the metering rod is, in a preferred embodiment, powered by a motor **64** (Figs. 3 and 5) which rotates the metering rod in a direction shown by arrow **66** which, in a preferred embodiment, is opposite to the direction of travel of the paper web or the surfaces of the backing rolls in the metering size press. This both provides very effective metering of the film applied to the paper web or backing rolls in the coating chamber as well as serving to maintain, or possibly slightly increase, the hydraulic pressure of the coating in the recirculation channel to aid in the looped flow of the coating in the coater head, particularly from the recirculation chamber to the mixing chamber.

Clearly, various modifications to the method and apparatus of this invention can be made without departing from the spirit and scope of the claims. Thus, the specific terms used to describe the preferred embodiments have been used in a generic and descriptive sense and not for purposes of limitations.

WHAT IS CLAIMED IS:

1. Apparatus (20, 20b) for coating a traveling paper web (W) with a film of coating, the apparatus operatively associated with an adjacent backing roll (14, 14b) and comprising, in combination:
    - a coater head (22, 22b) having an inlet (24, 24b) for receiving a supply of fresh coating;
    - a mixing chamber (26, 26b) in the coater head in fluid communication with the inlet for receiving the supply of fresh coating;
    - a feed channel (28, 28b) in the coater head in fluid communication with the mixing chamber for receiving coating from the mixing chamber;
    - a baffle (30, 30b) mounted in the apparatus and operatively associated with the feed channel (28, 28b) and having an edge (32, 32b) disposed in spaced adjacency with the surface (15) of the backing roll, and substantial parallel thereto, so as to form an overflow gap (60, 60b) with either the paper web surface to be coated, when the web is supported on the backing roll surface, or the backing roll surface, when the paper web is not supported on the backing roll surface, and to provide for the escape of coating therethrough when coating is flowed through the feed channel;
    - a coating chamber (18, 18b) in the coater head in fluid communication with the feed channel, and so constructed and arranged as to be open toward the backing roll for applying a film of coating to either the paper web surface to be coated, when the web is supported on the backing roll surface, or on the backing roll surface, when the paper web is not supported on the backing roll surface;
- recirculation means (48, 50, 54, 58; 48b, 50b, 54b, 58b) in the

coater head, and in fluid communication with the coating chamber and the mixing chamber for returning coating from the coating chamber to the mixing chamber to be combined with the fresh coating, and to establish, together with the feed channel, a continuous flow loop for circulation of coating within the coater head.

2. Apparatus for coating a traveling paper web as set forth in claim 1, wherein:

a blade is (36, 36b) mounted in the coater head to define, with the surfaces of the backing roll, the coating chamber (18, 18b) which extends downstream in the apparatus, the blade having a proximate end mounted in the coater head and a distal end extending downstream.

3. Apparatus for coating a traveling paper web as set forth in claim 1, wherein:

the coater head includes a stabilizer surface (51, 51b) for defining a part of the coating chamber for assisting in the flow of coating downstream and against either the surface of the paper web to be coated or on the surface (15) of the backing roll.

4. Apparatus for coating a traveling paper web as set forth in claim 3, further including:

a blade (36, 36b) mounted in the coater head and having a distal end (38) extending downstream therein, and defining, with the surface of the backing roll (14, 14b), the coating chamber (18, 18b) on one surface (49) of the blade, and defining, with the coater head, a recirculation channel (54, 54b) on the other surface (52, 52b) of the blade.

5. Apparatus for coating a traveling paper web as set forth in claim 4, wherein:  
the extension of the blade from its mounting in the coater head to its distal end defines a converging coating channel (18) with the surface (15) of the backing roll.
6. Apparatus for coating a traveling paper web as set forth in claim 1, wherein:  
the recirculation means includes a recirculation channel (54).
7. Apparatus for coating a traveling paper web as set forth in claim 1, wherein:  
the recirculation means includes a plurality of flow metering orifices (58).
8. Apparatus for coating a traveling paper web as set forth in claim 1, further including:  
a metering rod holder (42, 42b) mounted in the apparatus for holding a rotatable metering rod (40, 40b) for nipping engagement with either the coated paper web or the surface of the associated backing roll downstream of the coating chamber;  
a metering rod (40, 40b) rotatably mounted in the metering rod holder.
9. Apparatus for coating a traveling paper web set forth in claim 8, further comprising:  
drive means (64, 64b) operatively connected to the metering bar for rotating the metering bar while the metering bar is in nipping, coating metering engagement with the coating material

against either the coated web (W) or the surface of the backing roll.

10. A method for coating a traveling paper web (W) with a film of coating, the paper web being either supported on the surface of a rotatable backing roll, or nipped against the surface (15) of the backing roll (14, 14b), the method comprising the steps of:

- 1) introducing a fresh supply of coating (25, 25b) into a coater head (22, 22b);
- 2) directing the fresh supply of coating into a mixing chamber (26, 26b) in the coater head;
- 3) flowing the coating from the mixing chamber into, and through, a feed channel (28, 28b) in the coater head;
- 4) dividing the coating exiting the feed channel into first and second portions (12, 11; 12b, 11b);
- 5) directing the first portion (12, 12b) into a coating chamber in the coater head, and directing the second portion (11, 11b) over a baffle (30, 30b) disposed in spaced adjacency with either the paper web supported on the backing roll (or the surface of the backing roll) to define a gap (60, 60b) therebetween, the second portion being sufficient to seal the gap from air moving with either the traveling paper web or the surface of the backing roll;
- 6) flowing the coating in the coating chamber in the downstream direction therein while maintaining a pressurized interface between the coating material and either the paper web, when the paper web is supported on the surface of the backing roll, or the surface of the backing roll, when the paper web is nipped against the surface of the backing roll downstream of the interface;
- 7) flowing the coating from the coating chamber into a recirculation chamber (54, 54b);

8) directing the coating from the recirculation chamber into the mixing chamber (22, 22b);

9) mixing the coating from the recirculation chamber (54, 54b) with the fresh coating in the mixing chamber (26, 26b).

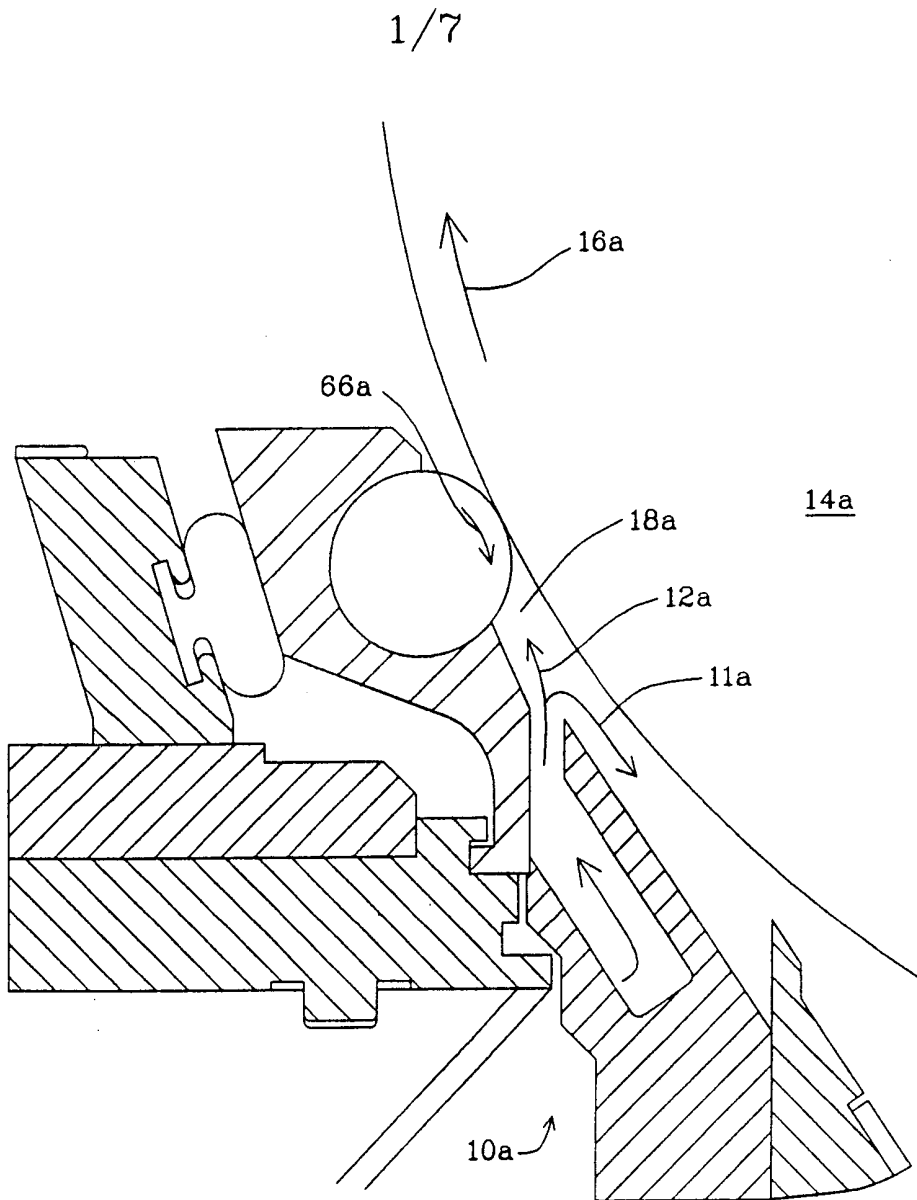

Fig. 1  
(Prior Art)

2/7

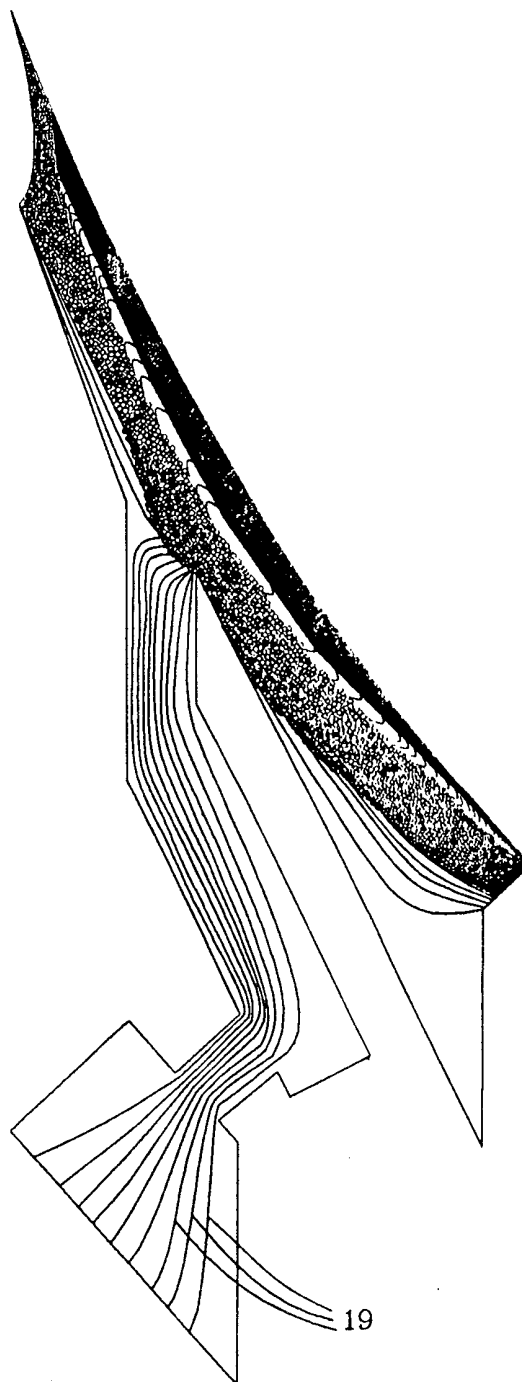

Fig. 2  
(Prior Art)



3/7

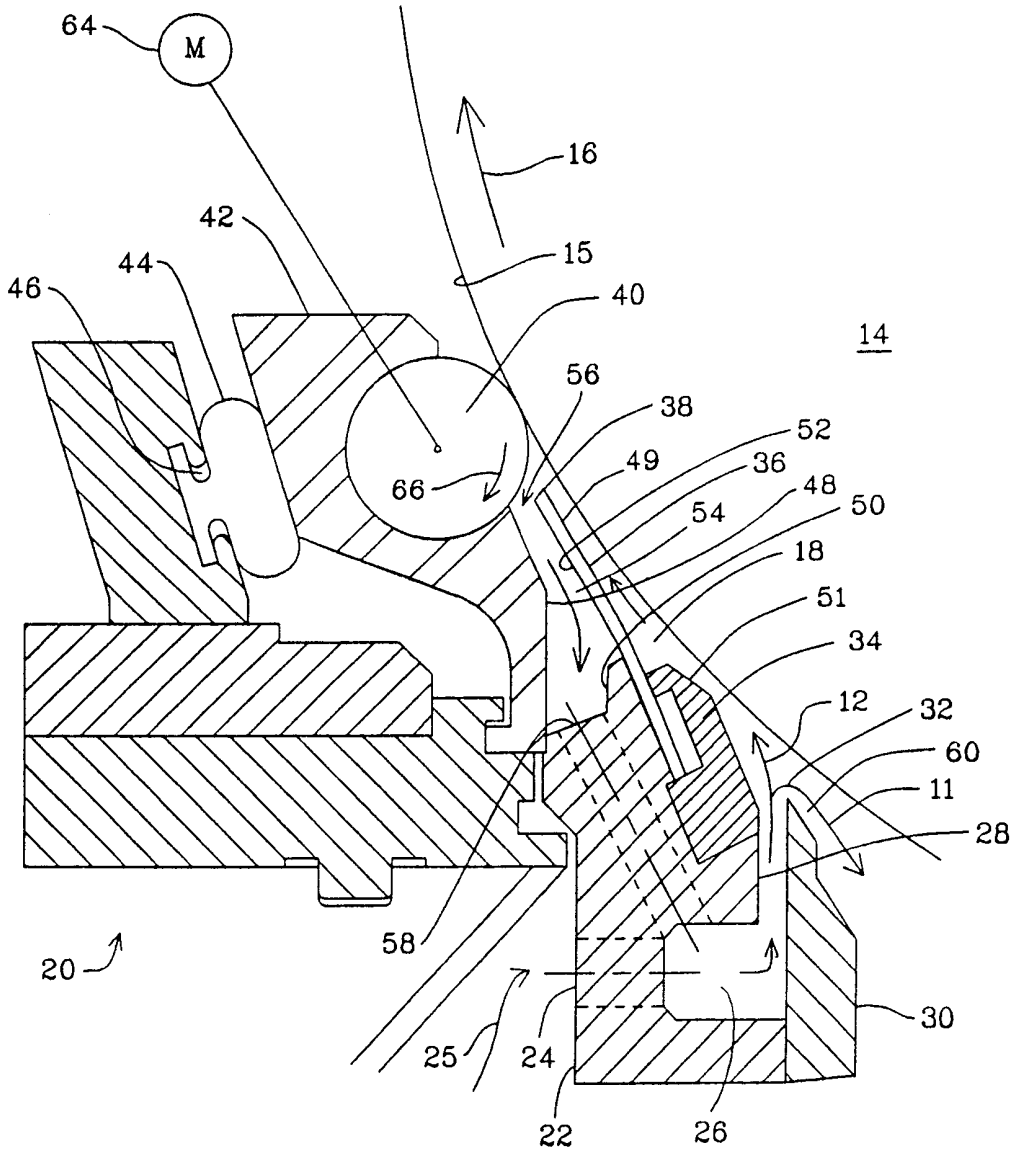

Fig. 3

4/7

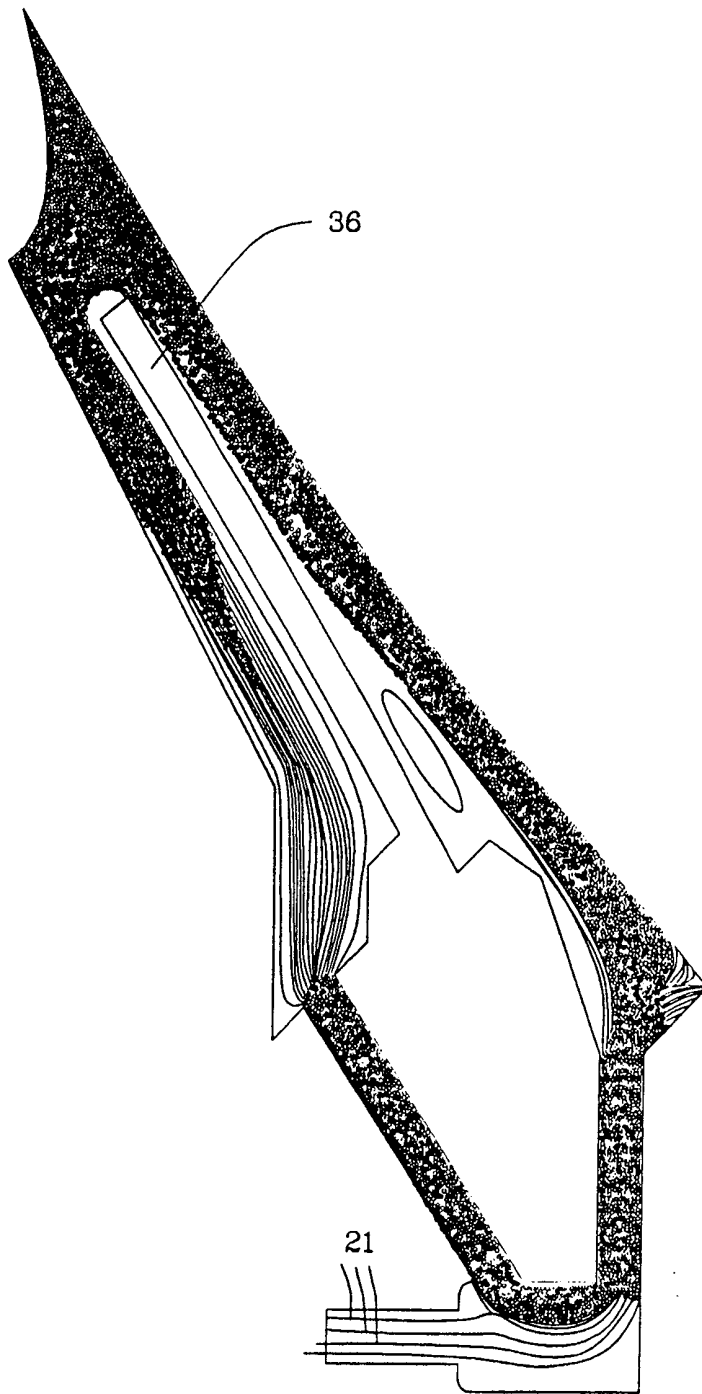

Fig. 4

5/7

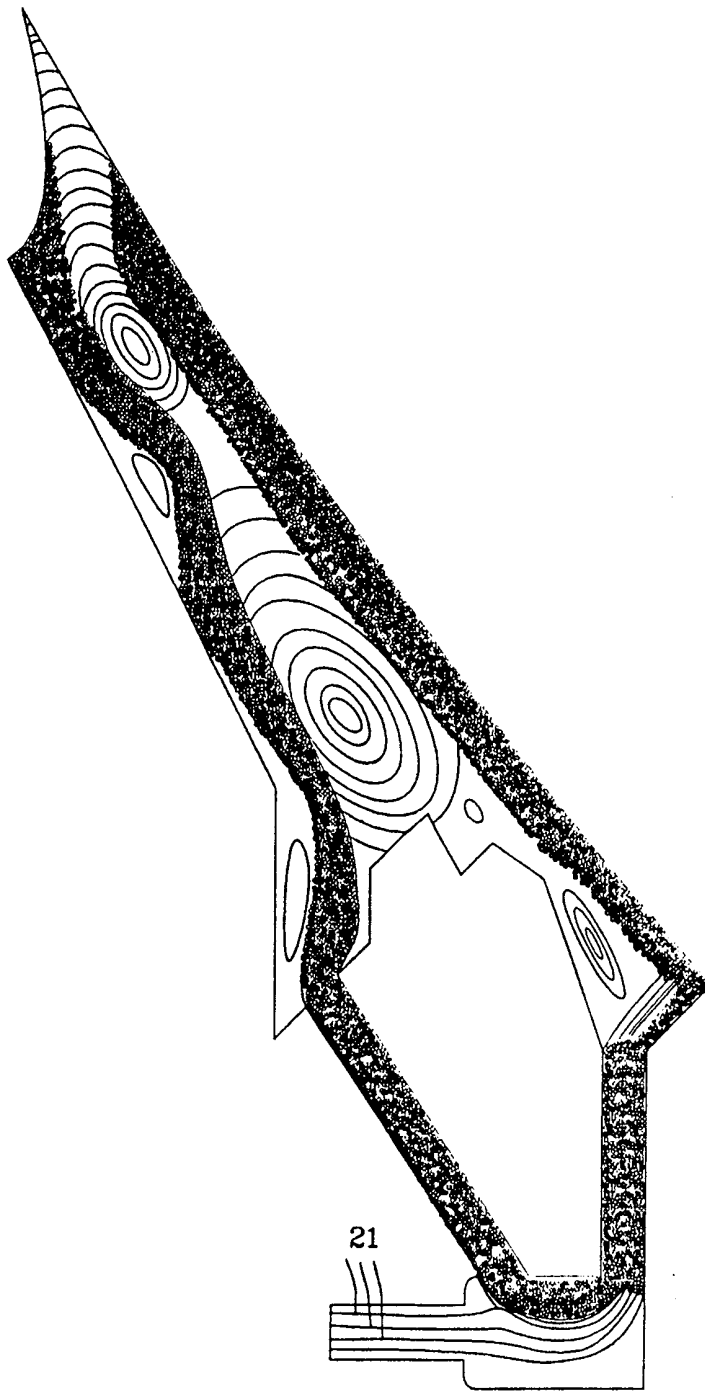

Fig. 4A

6/7

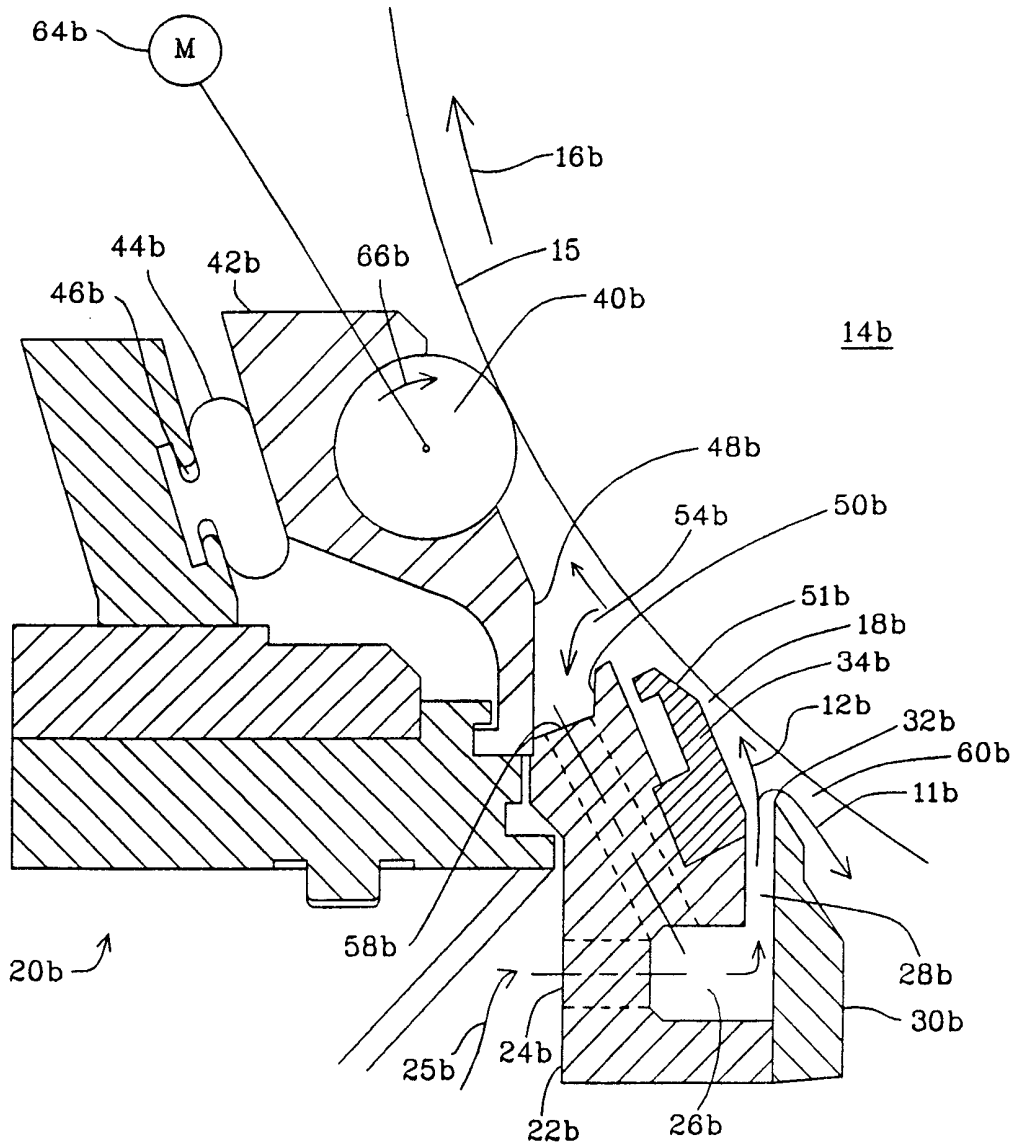

Fig. 5

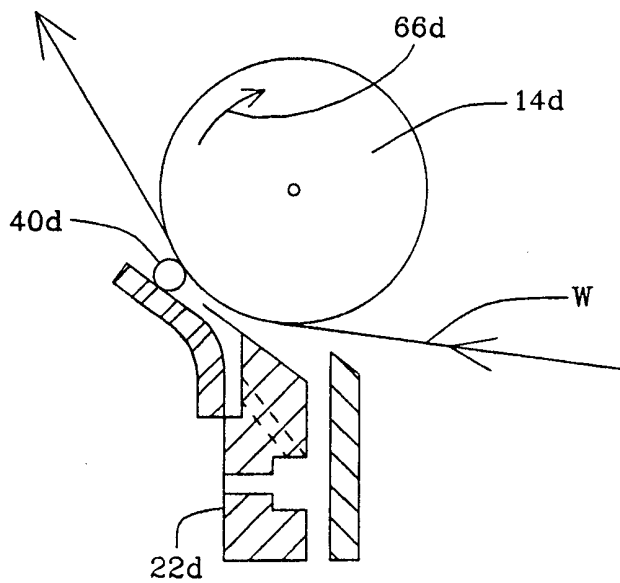

Fig. 6A

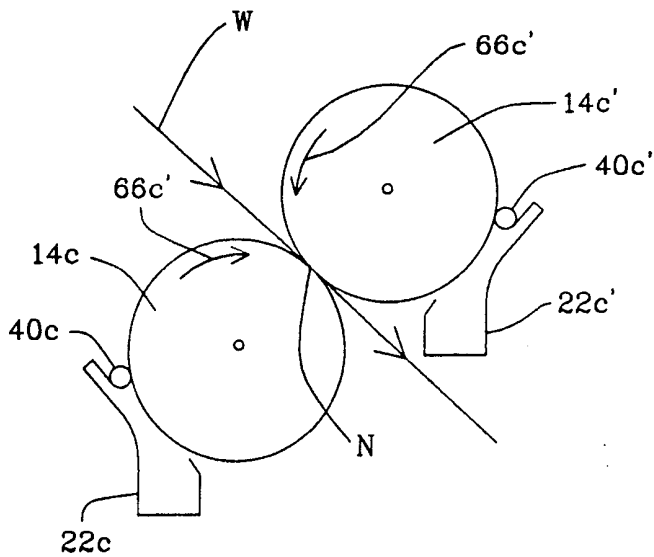

Fig. 6

# INTERNATIONAL SEARCH REPORT

Inter. Appl. Application No  
PCT/US 97/17417

<b>A. CLASSIFICATION OF SUBJECT MATTER</b> IPC 6 D21H23/32		
According to International Patent Classification (IPC) or to both national classification and IPC		
<b>B. FIELDS SEARCHED</b>		
Minimum documentation searched (classification system followed by classification symbols) IPC 6 D21H		
Documentation searched other than minimum documentation to the extent that such documents are included in the fields searched		
Electronic data base consulted during the international search (name of data base and, where practical, search terms used)		
<b>C. DOCUMENTS CONSIDERED TO BE RELEVANT</b>		
Category °	Citation of document, with indication, where appropriate, of the relevant passages	Relevant to claim No.
X	US 4 834 018 A (SOLLINGER HANS-PETER ET AL) 30 May 1989 see column 2, line 65 - column 3, line 16; claim 1; figure 4 ---	1-6,10
X	US 4 920 913 A (KNOP REINHARD ET AL) 1 May 1990 see column 2, line 67 - column 3, line 60; figures 2,3 ---	1,3,6,8,10
X	EP 0 514 735 A (VOITH GMBH J M) 25 November 1992 see column 3, line 26 - column 3, line 47; figure 2 ---	1,3,6,10
X	US 5 173 120 A (SUZUMURA HIROSHI ET AL) 22 December 1992 see the whole document ---	1-7,10
-/--		
<input checked="" type="checkbox"/> Further documents are listed in the continuation of box C. <span style="margin-left: 100px;"><input checked="" type="checkbox"/> Patent family members are listed in annex.</span>		
° Special categories of cited documents :		
*A* document defining the general state of the art which is not considered to be of particular relevance *E* earlier document but published on or after the international filing date *L* document which may throw doubts on priority claim(s) or which is cited to establish the publication date of another citation or other special reason (as specified) *O* document referring to an oral disclosure, use, exhibition or other means *P* document published prior to the international filing date but later than the priority date claimed	*T* later document published after the international filing date or priority date and not in conflict with the application but cited to understand the principle or theory underlying the invention *X* document of particular relevance; the claimed invention cannot be considered novel or cannot be considered to involve an inventive step when the document is taken alone *Y* document of particular relevance; the claimed invention cannot be considered to involve an inventive step when the document is combined with one or more other such documents, such combination being obvious to a person skilled in the art. *&* document member of the same patent family	
Date of the actual completion of the international search  <div style="text-align: center; font-size: 1.2em;">12 January 1998</div>	Date of mailing of the international search report  <div style="text-align: center; font-size: 1.5em; border: 1px solid black; padding: 2px;">23. 01. 98</div>	
Name and mailing address of the ISA European Patent Office, P.B. 5818 Patentlaan 2 NL - 2280 HV Rijswijk Tel. (+31-70) 340-2040, Tx. 31 651 epo nl, Fax: (+31-70) 340-3016	Authorized officer  <div style="text-align: center; font-size: 1.2em;">Nestby, K</div>	

# INTERNATIONAL SEARCH REPORT

Inter. Patent Application No  
PCT/US 97/17417

## C.(Continuation) DOCUMENTS CONSIDERED TO BE RELEVANT

Category	Citation of document, with indication, where appropriate, of the relevant passages	Relevant to claim No.
A	US 5 192 591 A (CHANCE JAMES L) 9 March 1993 see the whole document -----	1-5,10

# INTERNATIONAL SEARCH REPORT

Information on patent family members

Inter. Appl. Application No

PCT/US 97/17417

Patent document cited in search report	Publication date	Patent family member(s)	Publication date
US 4834018 A	30-05-89	DE 3438380 A	24-04-86
		AT 394667 B	25-05-92
		BR 8505399 A	05-08-86
		DE 3541416 A	27-05-87
		JP 1851405 C	21-06-94
		JP 61107973 A	26-05-86
		SE 465254 B	19-08-91
		SE 8504806 A	20-04-86
US 4920913 A	01-05-90	DE 3725545 A	09-02-89
		EP 0302233 A	08-02-89
EP 0514735 A	25-11-92	DE 4116729 A	26-11-92
		AT 119437 T	15-03-95
		CA 2069344 A	24-11-92
		DE 59201574 D	13-04-95
		ES 2070550 T	01-06-95
		FI 97406 B	30-08-96
		JP 5138106 A	01-06-93
US 5173120 A	22-12-92	DE 69012975 D	03-11-94
		DE 69012975 T	23-03-95
		EP 0436172 A	10-07-91
US 5192591 A	09-03-93	BR 9206747 A	10-01-95
		CA 2122611 A	27-05-93
		CN 1076141 A	15-09-93
		DE 69207209 D	08-02-96
		DE 69207209 T	27-06-96
		EP 0612363 A	31-08-94
		FI 942225 A,B,	13-05-94
		JP 2549061 B	30-10-96
		JP 6510702 T	01-12-94
		MX 9206580 A	01-05-93
		PL 169630 B	30-08-96
		WO 9310309 A	27-05-93