

★AGRO=

Q56

2000-291825/25

★RU 2129669-C1

Packless electric pump with brushless dc motor -

AGROINZHSTROI FIRM CO LTD 1998.06.24 1998RU-112002

X25 (1999.04.27) F04D 13/06

Addnl.Data: NAGAITSEV V I (NAGA/)

BUGURUSLANOV V V (BUGU/)

SLAVIN B S (SLAV/)

NOVELTY - Two conical parts of pump hermetically sealed housing form by their tapering ends pump inlet outlet. Electric motor stator disks is clamped through gaskets between widening ends. Coil sliding support is installed in central hole of stator disk. Sliding support carries rotor made of two parts arranged at both sides of stator disk. Working wheel of centrifugal pump is secured on one of rotor parts. Slots made on stator disk periphery are designed to pass handled liquid from inlet conical plane of housing to outlet plane. So, electric motor placed in inner space of pump housing is washed by handled liquid. Leads of armature winding and magnetically sensitive microcircuit poured in stator plastic disk come out from disk end face. Single-phase armature winding has center tap connected with positive potential of DC source, and extreme points of winding are connected to source minus through commutator electronic switches. Outlet of magnetically sensitive microcircuit is connected with control input of one switch, and control input of second switch is connected, through resistor, with point of connected of first switch to extreme point of winding. Permanent magnets of alternating polarity nonuniformly spaced over circumference are built into motor rotor.

USE - Mechanical engineering; sealed pumps.

ADVANTAGE - Simplified design of pump and process of manufacture, eliminated pulsed current consumption, decreased required power output of source, provision of free rotation of rotor with motor switched off. 3 cl, 3 dwg (0pp Dwg.No.1/1)

N2000-218758

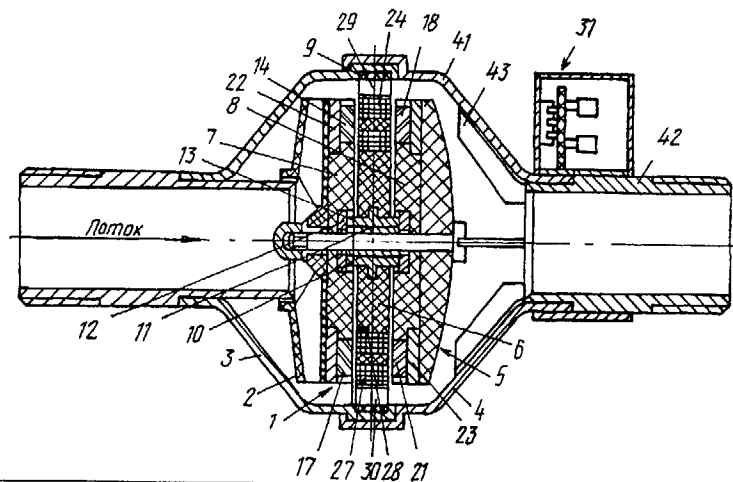

© 2000 Derwent Information

14 Great Queen Street London WC2B 5DF England UK

Derwent Information

1725 Duke Street Suite 250 Alexandria VA 22314 USA