



(11) **EP 1 982 939 B1**

(12) **EUROPEAN PATENT SPECIFICATION**

(45) Date of publication and mention
of the grant of the patent:
24.07.2013 Bulletin 2013/30

(51) Int Cl.:
B65H 19/29 ^(2006.01) **B65H 19/26** ^(2006.01)
B65H 19/28 ^(2006.01) **B65H 19/22** ^(2006.01)

(21) Application number: **07007747.4**

(22) Date of filing: **17.04.2007**

(54) **Web material winding machine**

Wickelmaschine für Bahnmaterial

Machine de renvideur de matériau de toile

(84) Designated Contracting States:
DE EE GB IT PL SK

(43) Date of publication of application:
22.10.2008 Bulletin 2008/43

(73) Proprietor: **Chan Li Machinery Co., Ltd.**
Gueishan Township
T'ao yuan 333 (TW)

(72) Inventor: **Tsai, Tung-I**
Taoyuan 333 (TW)

(74) Representative: **Wilson, Peter David George**
Novagraaf UK
12 Meridian Way
Meridian Business Park
Norwich
NR7 0TA (GB)

(56) References cited:
EP-A- 1 520 814 **EP-A1- 1 232 980**
WO-A-01/64563 **WO-A-2004/035441**
WO-A-2007/083336 **US-A- 6 056 229**

EP 1 982 939 B1

Note: Within nine months of the publication of the mention of the grant of the European patent in the European Patent Bulletin, any person may give notice to the European Patent Office of opposition to that patent, in accordance with the Implementing Regulations. Notice of opposition shall not be deemed to have been filed until the opposition fee has been paid. (Art. 99(1) European Patent Convention).

Description**FIELD OF THE INVENTION**

[0001] The present invention relates to a winding machine, and more particularly to a winding machine for winding a web material around a core tube to producing a wound roll thereof.

BACKGROUND OF THE INVENTION

[0002] Winding machine is commonly used in the pulp and paper industry and textile industry for producing smaller diameter logs or rolls of web material from large diameter parent rolls. For example, winding machines are used in the paper converting industry to produce rolls of toilet paper, kitchen towel and the like.

[0003] A conventional winding machine is provided with a presser which has a surface with high coefficient of friction and which exerts a pressure to impede the forward movement of the web material. This results to the tearing off of the web material. Alternatively, a severing means having sharp, saw-toothed blades is used to sever the web material. An example is shown in U.S. Patent No. 5,979,818 which discloses a rewinding machine for the formation of logs of web materials. The closest prior art is considered to be represented by the device disclosed in WO01/64563A. In the patent, a material-severing device is provided for severing the web material when the winding of web material is completed.

[0004] Either the presser or severing means has to work with a stroke and timing control device, such as an automatic timing control roller, an automatic timing control cam or linkage assembly, etc. The presser is driven to act on the web material at a predetermined severing timing by the stroke and timing control device, such as at pressing timing or clipping timing. Such a design inevitably increases the manufacture cost and complicates the control system.

[0005] Moreover, it is necessary to precisely control the timing or stroke for the winding device. Once the presser is damaged, the stroke is offset out of a preset stroke, or the timing control is not correct and lapses from the preset timing, the web material is cut at the improper time and it would result to poor quality of the logs.

[0006] Thus, it is desired to provide a winding machine that does not require the installation of any pressing means to simplify the control of the winding machine and the manufacture cost.

SUMMARY OF THE INVENTION

[0007] A primary object of the present invention is to provide a web material winding device which is able to tear a web material by arranging a transporting passage. The transporting passage has a dimension that is slightly smaller than the diameter of the core tube. The new core tube conveying on the transporting passage presses on

the web material, generating an interference to the speed of the web material and causing the tearing of the web material. No presser or severing means is needed for severing the web material.

5 [0008] Another object of the present invention is to provide a winding machine that tears the web material to complete a roll whenever a new core tube is delivered to the transporting passage. No timing control device is needed for controlling the tearing of the web material.

10 [0009] To fulfill the above objects, the present invention provides a web material winding machine as defined in the claims that follow.

[0010] In outline, the winding machine comprises a core tube storage tank, a guiding unit, a transmission means, a web material feeding assembly, a gripping assembly and a second gluing mechanism. A core tube is glued with initial glue and conveyed from the guiding unit to the transmission means. Meanwhile, the web material is fed by the web material feeding assembly to the transmission means at a normal speed. The transmission means pushes the core tube to move through a transporting passage to the gripping assembly and the web material is stuck to the core tube. The web material winds around the core tube at the winding region. When the winding is nearly completed, a new core tube is conveyed to the transporting passage and interferes the speed of web material, causing the web material to tear along the perforation line. A tail glue is applied to the completed core tube by the second gluing mechanism and a roll is produced.

BRIEF DESCRIPTION OF THE DRAWINGS

[0011] The structure and the technical means adopted by the present invention to achieve the above and other objects can be best understood by referring to the following detailed description of the preferred embodiments and the accompanying drawings, wherein:

40 Fig. 1 is a schematic view of a web material winding machine constructed in accordance with a preferred embodiment of the present invention;

45 Fig. 2 is an exploded perspective view showing a second gluing mechanism of the web material winding machine of Fig. 1;

50 Fig. 3 is a schematic view showing the delivery of core tubes to a guiding unit of the web material winding machine of Fig. 1;

Fig. 4 is a schematic view showing that a core tube is conveyed to a transmission means of the web material winding machine;

55 Fig. 5 is a schematic view showing that the core tube is conveyed to a transporting passage of the transmission means;

Fig. 6 is a schematic view showing that a web material is stuck to the core tube;

Fig. 7 is a schematic view showing a working core tube is gripped by a gripping arm;

Fig. 8 is a schematic view showing that the working core tube is proceeding winding work in the winding region;

Fig. 9 is a schematic view showing that the winding of the working core tube is nearly completed and a new core tube is conveyed to the transmission means;

Fig. 10 is a schematic view showing that the web material is stuck on the new core tube that enters the transporting passage;

Fig. 11 is a schematic view showing that the new working core tube presses on the web material;

Fig. 12 is a schematic view showing the tearing of web material; and

Fig. 13 is a schematic view showing that the roll leaves the winding region and the new core tube is conveyed to the winding region.

DETAILED DESCRIPTION OF THE PREFERRED EMBODIMENTS

[0012] With reference to the drawings and in particular to Fig. 1 which is the schematic view of a web material winding machine constructed in accordance with a preferred embodiment of the present invention. A web material winding machine 100 is adapted to wind a web material 200 to a core tube 300. The winding machine 100 includes a core tube storage tank 1, a guiding unit 2, a transmission means 3, a web material feeding assembly 4, a gripping assembly 5 and a second gluing mechanism 6.

[0013] The core tube storage tank 1 contains with a plurality of core tubes 300 and has an opening (not labeled) at the right bottom corner for supplying the core tubes 300. The guiding unit 2 communicates with the opening of the core tube storage tank 1 and includes a guiding passage 21, a first gluing mechanism 22 and a pushing mechanism 23. The first gluing mechanism 22 contains glue. The guiding passage 21 connects the core tube storage tank 1 to the pushing mechanism 23. Through the guiding passage 21, the core tube 300 is conveyed from the core tube storage tank 1 to the platform of the pushing mechanism 23. Then, the first gluing mechanism 22 applies an initial glue to the core tube 300 on the platform of the pushing mechanism 23. The pushing mechanism 23 has a retractable arm that pushes the glued core tube 300 along the platform to the transmis-

sion means 3.

[0014] The transmission means 3 includes an oscillable feeding arm 31, a roller assembly 32 and a rolling guiding mechanism 33. The feeding arm 31 is located above the pushing mechanism 23 and has a fixed end 311, a pushing end 312 and a pushing roller 313. The feeding arm 31 is pivoted at the fixed end 311 such that the pushing end 312 is movable along a first oscillating orbit I as shown in Fig. 3. The pushing roller 313 is mounted to the pushing end 312 of the feeding arm 31 for pushing the core tube 300 forward along the oscillating orbit I.

[0015] The roller assembly 32 includes a first roller 321, a second roller 322 and a third roller 323. The first roller 321 is located nearby the feeding arm 31. The second roller 322 and the third roller 323 are below the first roller 321 and are respectively positioned at the two sides of the first roller 321. A clearance is formed between the first roller 321 and the second roller 322. The clearance is on the oscillating orbit I. A clearance is also formed between the second roller 322 and the third roller 323.

[0016] The rolling guiding mechanism 33 is arranged between the first roller 321 and the second roller 322, forming a continuous curved surface between the first roller 321 and the second roller 322. The curved surface and the first roller 321 defines a transporting passage 34 for conveying the core tube 300 therethrough.

[0017] In order to strengthen the interference action of the new core tube 300 to the feeding of web material 200 to the working core tube 300a (as shown in Fig. 5), the transporting passage 34 is designed to have a width slightly smaller than the diameter of the core tube 300. Therefore, when the core tube 300a is conveyed along the transporting passage 34, the core tube 300a is squeezed to deform slightly, turning into oval shape.

[0018] The web material 200 is fed through the web material feeding assembly 4 to the roller assembly 32. The web material feeding assembly 4 includes a stationary counter roller 41, a perforation roller 42 and a feeding roller 43. The counter roller 41 is provided with a counter blade 411, and the perforation roller 42 is provided with a plurality of blades 421 regularly spaced at the periphery of the perforation roller 42. The counter blade 411 of the counter roller 41 operates in coordination with the blades 421 of the perforation roller 42. During operation, the web material 200 is conveyed to the feeding roller 43 through a passage between the counter roller 41 and the perforation roller 42. Meanwhile, the blades 421 of the perforation roller 42 pierce through the web material 200 to the counter blade 411 of the counter roller 41, forming a line of perforations across the web material 200. The perforation roller 42 is driven to rotate at a predetermined speed such that a perforation line is produced at the web material 200 for each predetermined distance. The feeding roller 43 is located below the second roller 322 for feeding the web material 200 to the second roller 322.

[0019] The gripping assembly 5 includes an oscillable gripping arm 51 and a gripping roller 52. The gripping arm 51 has a fixed end 511 and a gripping end 512. The

gripping end 512 is pivoted at the fixed end 511, such that the gripping end 512 is movable along a second oscillating orbit II as shown in Fig. 3. The gripping roller 52 is mounted to the gripping end 512 and is adjacent to the first roller 321 and above the third roller 323 for gripping the working core tube 300a. A winding region 53 is defined among the first roller 321, the third roller 323 and the gripping roller 52.

[0020] Please refer to Fig. 2, which is an exploded perspective view showing a second gluing mechanism of the web material winding machine of Fig. 1. The second gluing mechanism 6 is arranged adjacent to the third roller 323 and tilts downward. The second gluing mechanism 6 includes a cover plate 61, an injector 62, a glue supply 63 and a casing 64. The cover plate 61, the injector 62 and glue supply 63 are aligned with each other and are piled together from top to bottom in sequence. The casing 64 is fastened to the plate 61 by screws for accommodation and protection of the injector 62 and glue supply 63 therebetween.

[0021] The cover plate 61 is perforated with a plurality of apertures 611. The injector 62 is provided with a support base 621 and a plurality of injecting needles 622. Each of the injecting needles 622 aligns with an aperture 611 located above. The glue supply 63 comprises a support base 631, a plurality of tubes 632 and a plurality of ducts 633. The tubes 632 are supported on the support base 631. Each of the tubes 632 is connected with a duct 633 which is aligned with an injecting needle 622 above the glue supply 63. The tubes 632 contain glue and supply the glue through the ducts 633 to the injecting needles 622. When the roll 400 rolls (as shown in Fig. 9) across the cover plate 61, the injector 62 injects tail glue through the apertures 611 to the web material 200 of the roll 400.

[0022] Please refer to Figs. 3 to 13 that show an operation of the web material winding machine of Fig. 1. Fig. 3 is a schematic view showing the delivery of core tubes to the guiding unit of the web material winding machine of Fig. 1. As shown, the core tubes 300 are delivered one by one from the core tube storage tank 1 through the guiding passage 21 to the platform of the pushing mechanism 23. The first gluing mechanism 22 of the guiding unit 2 applies initial glue to the core tube 300.

[0023] Fig. 4 is a schematic view showing that the core tube is conveyed to the transmission means 3 of the web material winding machine. The glued core tube 300 is pushed forward by the retractable arm of the pushing mechanism 23 along the platform to the transmission means 3. In the meantime, the web material 200 is conveyed through the web material feeding assembly 4 to the roller assembly 32. The blades 421 of the perforation roller 42 works with the counter blade 411 of the counter roller 41, producing a line of perforations across the web material 200.

[0024] Fig. 5 is a schematic view showing that the core tube is conveyed to the transporting passage of the transmission means. The feeding arm 31 oscillates around the fixed end 311, and accordingly, the pushing end 312

moves along the first oscillating orbit I. It can be seen from Fig. 5 that the pushing roller 313 pushes the core tube 300 to displace into the transporting passage 34. As mentioned, the transporting passage 34 has a width slightly smaller than the diameter of the core tube 300. Therefore, when the core tube 300a is conveyed along the transporting passage 34, the core tube 300a is squeezed to oval shape.

[0025] Once entering the transporting passage 34, the core tube 300 contacts the web material 200 and sticks the web material 200 by the initial glue, forming a working core tube 300a, as it can be seen from Fig. 6. The relative motion between the first roller 321 and the rolling guiding mechanism 33 drives the working core tube 300a to move along the transporting passage 34. Fig. 7 is a schematic view showing that the working core tube 300a reaches the winding region 53 of the gripping assembly 5 and is gripped by the gripping arm 51. At the same time, the feeding arm 31 swings back to its original position.

[0026] Please refer to Fig. 8. The working core tube 300a is driven to rotate to wind the web material 200 at the winding region 53. When the winding of the working core tube 300a is nearly completely, the first gluing mechanism 22 applies initial glue to a new core tube 300. The operation of the guiding unit 2 is controlled by a control means. The control means may be any conventional control device that can be preset with various operation parameters, e.g. the timing of release of core tube from the guiding unit 2.

[0027] Fig. 9 is a schematic view showing the new core tube 300 is conveyed to the transmission means 3. The glued new core tube 300 is pushed forward by the arm of the pushing mechanism 23 along the platform to the transmission means 3. The working core tube 300a at the winding region 53 keeps on winding at the normal speed.

[0028] Fig. 10 is similar to Fig. 3. In the drawing, the new core tube 300 is pushed to enter the transporting passage 34 by the feeding arm 31. Once entering the passage 34, the core tube 300 contacts the web material 200 and sticks the web material 200 by the initial glue, forming a new working core tube 300a.

[0029] Please refer to Fig. 11, a schematic view showing the new core tube presses on the web material feeding to the winding core tube. The new core tube 300a moves through the transporting passage 34 and is squeezed to become oval shape. The new core tube 300a presses on the web material 200, and therefore, the new core tube 300a interferes the movement of the web material 200. This interference action slows down the feeding speed of the web material 200 or even stops the feeding of the web material 200 to the working core tube 300a. However, the working core tube 300a at the winding region 53 keeps rotation at its normal speed.

[0030] Accordingly, a pulling force is generated to the web material 200. Fig. 12 is a schematic view showing the tearing of the web material. The pulling force causes the web material 200 to tear along the perforation line.

Hence, the winding of the working core tube 300a is completed and a roll 400 is produced.

[0031] Fig. 13 shows that the roll 400 leaves the winding region 53 and the new core tube 300a is conveyed to the winding region 53. As the second gluing mechanism 6 tilts downward, the roll 400 leaves the winding region 53 and rolls across the cover plate 61 of the second gluing mechanism 6. At this moment, the second gluing mechanism 6 injects tail glue through the apertures 611 to the web material 200 of the roll 400. The web material 200 is adhered by the tail glue to the roll 400. The processing to the roll 400 is accomplished. The injection of the final glue by the second gluing mechanism is also controlled by the control means. Meanwhile, the new working core tube 300a is conveyed to the winding region 53.

[0032] At predetermined time, the control means drives the injector 62 and the glue supply 63 to lift up such that the injecting needles 622 reaches the apertures 611 and are close to the roll 400, and injecting needles 622 inject tail glue to the roll 400. After injection, the injector 62 and the glue supply 63 returns to its original position. The upward and downward movement of the injector 62 and the glue supply 63 are achieved by a retractable lifting device. The lifting device may comprise spiral pins, springs or other effective elements.

[0033] In the present invention, the tearing of web material is achieved by the interference of the new core tube to the working core tube. The winding machine tears the web material whenever a new core tube is delivered to the transporting passage. No presser or severing means is required. Hence, no time control device is needed for controlling the working of the presser. The manufacture, operation and maintenance of the winding machine are simplified. It significantly reduces the manufacture, operation and maintenance cost.

[0034] Although the present invention has been described with reference to the preferred embodiments thereof, it is apparent to those skilled in the art that a variety of modifications and changes may be made without departing from the scope of the present invention which is intended to be defined by the appended claims.

Claims

1. A winding machine (100) for winding a web material, the winding machine (100) comprising:

a core tube storage tank (1), which contains a plurality of core tubes (300);

a guiding unit (2), which is connected to the core tube storage tank (1) for delivery of the core tubes (300) one by one from the core tube storage tank (1) according to a preset timing and has a first gluing mechanism (22) for injecting an initial glue to the core tubes (300);

a transmission means (3), comprising:

an oscillable feeding arm (31), which comprises a fixed end (311) and a pushing end (312) pivoted at the fixed end (311), wherein the pushing end (312) for pushing the core tube operates to oscillate along a first oscillating orbit (I);

a roller assembly (32) comprising:

a first roller (321), which is arranged nearby the oscillatable feeding arm (31);

a second roller (322), which is arranged below the first roller (321), and a clearance is formed between the first roller (321) and the second roller (322) at the first oscillating orbit (I); and

a third roller (323), which is arranged below the first roller (321); and

a rolling guiding mechanism (33), which is arranged between the second roller (322) and the third roller (323), and defining a transporting passage (34) between the first roller (321) and the rolling guiding mechanism (33);

a web material feeding assembly (4), which is adjacent to the transmission means (3) for feeding the web material (200) to the transmission means (3); and

an oscillable gripping assembly (5) comprising:

an oscillable gripping arm (51), which has a fixed end (511) and a gripping end (512) pivoted at the fixed end (511), the gripping end (512) being operable to oscillate along a second oscillating orbit (II); and

a gripping roller (52), which is mounted to the gripping end (512), wherein a winding region (53) is defined among the first roller (321), the third roller (323) and the gripping roller (52);

in operation, the core tube (300) is fed from the core tube storage tank (1) to the guiding unit (2), applied with the initial glue by the first gluing mechanism (22) and conveyed to the transmission means (3) which pushes the core tube (300) from the guiding unit (2) to the transporting passage (34), and meanwhile, the web material (200) is fed from the web material feeding assembly (4), stuck on the core tube (300) at the transporting passage (34) and wound around the core tube (300) to form a working core tube (300a), and then the working core tube (300a) is conveyed through the transporting passage (34) to the winding region (53) and proceeding winding at a predetermined speed, a new core tube (300) being fed by the guiding unit (2) to the transmission means (3)

when the working core tube (300a) completing winding work, and the transportation of the new core tube (300) at the transporting passage (34) interferes the speed of the web material (200), causing the tearing of the web material (200) and a roll (400) is produced.

2. The winding machine (100) as claimed in claim 1, **characterized in that** the guiding unit (2) further comprises:

a guiding passage (21), which is connected to the core tube storage tank (1) for delivery of core tubes (300) from the core tube storage tank (1) to the first gluing mechanism (22) for applying the initial glue to the core tubes (300); and a pushing mechanism (23) which pushes the core tube (300) from the first gluing mechanism (22) to the transmission means (3) after the core tube (300) is applied with the initial glue.

3. The winding machine (100) as claimed in claim 1, **characterized in that** the pushing end (312) of the oscillable feeding arm (31) further comprises a pushing roller (313).

4. The winding machine (100) as claimed in claim 1, **characterized in that** the winding machine (100) further comprises a second gluing mechanism (6) including a cover plate (61), an injector (62) and a glue supply (63), which are aligned with each other and piled together from top to bottom in sequence, the second gluing mechanism (6) injecting tail glue to the roll (400).

5. The winding machine (100) as claimed in claim 4, **characterized in that** the cover plate (61) is provided with a plurality of injecting apertures (611).

6. The winding machine (100) as claimed in claim 4, **characterized in that** the injector (62) is provided with a plurality of injecting needles (622) correspondingly located under the injecting apertures (611).

7. The winding machine (100) as claimed in claim 4, **characterized in that** the glue supply (63) is provided with a plurality of tubes (632) containing glue and each of the tubes (632) is connected with a duct (633) for providing glue to the corresponding injecting needles (622).

8. The winding machine (100) as claimed in claim 1, **characterized in that** the web material feeding assembly (4) further comprising:

at least one counter roller (41) provided with at least one counter blade (411); and at least one perforation roller (42) provided with a plurality of blades (421) regularly spaced at

the periphery of the perforation roller (42); **characterized in that** the counter blade of the counter roller (41) operates in coordination with the blades (421) of the perforation roller (42) to form a line of perforations at the web material (200).

Patentansprüche

1. Haspelmaschine (100) zum Aufhaspeln eines bahnförmigen Materials; diese Haspelmaschine (100) umfasst:

einen Speicherbehälter (1) für Wickelhülsen, der eine Vielzahl von Wickelhülsen (300) enthält;
eine Führungseinheit (2), verbunden mit dem Speicherbehälter (1) für Wickelhülsen, für die Zustellung vereinzelter Wickelhülsen (300) aus dem Speicherbehälter (1) in einem vorgegebenen Zustelltakt, und die eine erste Klebevorrichtung (22) für ein erstes Aufspritzen von Klebmasse auf die Wickelhülsen (300) aufweist;
ein Übergabemittel (3), umfassend:

einen schwingbaren Zustellarm (31), der ein festes Ende (311) und ein am festen Ende (311) schwenkbar befestigtes Abstoßende (312) aufweist, wobei das Abstoßende (312) zum Abstoßen der Wickelhülsen in eine schwingende Bewegung entlang einer ersten Umlaufbahn (I) versetzt wird.
eine Walzenbaugruppe (32), umfassend:

eine erste Walze (321) die in der Nähe des schwingbaren Zustellarms (31) angeordnet ist;

eine zweite Walze (322), die unter der ersten Walze (321) angeordnet ist, wobei ein Luftspalt zwischen der ersten Walze (321) und der zweiten Walze (322) an der ersten Schwingungsbahn (I) gebildet wird;

und

eine dritte Walze (323), die unter der ersten Walze (321) angeordnet ist;

und

ein rollend ausgebildeter Führungsmechanismus (33) angeordnet zwischen der zweiten Walze und der dritten Walze, der eine Transportpassage (34) zwischen der ersten Walze (321) und dem rollend ausgebildeten Walzenführungsmechanismus (33) definiert,
eine Zustellbaugruppe (4) für die Materialbahnzustellung, die angrenzend an das Übergabemittel (3) angeordnet ist

und der Zustellung von Bahnmateri-
 (200) zu dem Übergabemittel (3) dient,
 und
 eine schwingbare Greifervorrichtung
 (5), umfassend:

einen schwingbaren Greiferarm
 (51), der ein festes Ende (511) und
 ein Greiferende (512) besitzt, das
 an seinem festen Ende (511)
 schwenkbar ausgeführt ist, wobei
 das Greiferende (512) entlang ei-
 ner zweiten Schwingungsbahn (II)
 schwingen kann;

und
 eine Greiferwalze (52), die am
 Greiferende (512) montiert ist; wo-
 bei von der ersten Walze (321), der
 dritten Walze (323) und der Grei-
 ferwalze (52) ein Haspelraum (53)
 definiert wird;

im Betrieb wird die Wickelhülse
 (300) vom Wickelhülsen-Spei-
 cherbehälter (1) zur Führungsein-
 heit (2) gefördert, von der Klebe-
 vorrichtung (22) zum ersten Mal
 mit Klebmasse beschichtet und
 dann zur Übergabevorrichtung
 (3) befördert, die die Wickelhülse
 (300) von der Führungseinheit (2)
 in die Transportpassage (34)
 schiebt, während das bahnförmige
 Material (200) von der Bahnmateri-
 al-Zustellvorrichtung (4) zuge-
 stellt wird, an der Transportpassa-
 ge (34) auf die Wickelhülse (300)
 aufgeklebt und um die Wickelhülse
 (300) gewickelt wird, so dass eine
 funktionstüchtige Wickelhülse
 (300a) entsteht, wonach diese
 funktionstüchtige Wickelhülse
 (300a) durch die Transportpassa-
 ge (34) in den Haspelbereich (53)
 gefördert wird, wo dann der Has-
 pelvorgang mit einer vorgegebenen
 Geschwindigkeit abläuft, wäh-
 rend eine neue Wickelhülse (300)
 von der Führungseinheit (2) der
 Übergabevorrichtung (3) zuge-
 stellt wird, sobald an der funktions-
 tüchtigen Wickelhülse (300a) der
 Wickelvorgang abgeschlossen ist;
 bewirkt der Transport der neuen
 Wickelhülse (300) an der Trans-
 portpassage (34) eine Änderung der
 Geschwindigkeit des Bahnmateri-
 als (200), so dass das Bahnmateri-
 al (200) abreißt und eine Rolle

(400) produziert wird.

2. Haspelmaschine (100) gemäß Anspruch 1, **dadurch gekennzeichnet, dass** die Führungseinheit (2) fol-
 gende weitere Positionen umfasst:

eine Führungspassage (21), verbunden mit dem
 Speicherbehälter (1) für Wickelhülsen, für die
 Zustellung von Wickelhülsen (300) aus dem
 Speicherbehälter (1) zu der ersten Klebevorrich-
 tung (22) für das erste Auftragen von Klebmasse
 auf die Wickelhülsen (300); und
 einen Schiebemechanismus (23), der die Wik-
 kelhülse von der ersten Klebevorrichtung (22)
 zur Übergabevorrichtung (3) transportiert. so-
 bald die anfängliche Menge Klebmasse auf die
 Wickelhülse aufgetragen worden ist.

3. Haspelmaschine (100) gemäß Anspruch 1, **dadurch gekennzeichnet, dass** das Abstoßende (312) des
 schwingbaren Zustellarms (31) des Weiteren eine
 Abstoßwalze (313) aufweist.

4. Haspelmaschine (199) gemäß Anspruch 1, **dadurch gekennzeichnet, dass** die Haspelmaschine (100)
 des Weiteren eine zweiten Klebevorrichtung (6)
 einschließlich der Deckplatte (61), eines Injektors (62)
 und einer Klebmassenversorgung (63) umfasst, die
 miteinander fluchtend angeordnet ausgerichtet und
 in der angegebenen Folge von oben nach unten ge-
 stapelt angeordnet sind, wobei die zweite Klebevor-
 richtung (6) eine letzte Menge Klebmasse auf die
 Rolle (400) spritzt.

5. Haspelmaschine (100) gemäß Anspruch 4, **dadurch gekennzeichnet, dass** die Deckplatte (61) eine
 Vielzahl von Einspritzöffnungen (611) aufweist.

6. Haspelmaschine (100) gemäß Anspruch 4, **dadurch gekennzeichnet, dass** der Injektor (62) eine Viel-
 zahl von Einspritzdüsen (622) aufweist, die in
 den Einspritzöffnungen (611) entsprechenden Posi-
 tionen unter diesen angeordnet sind.

7. Haspelmaschine (100) gemäß Anspruch 4, **dadurch gekennzeichnet, dass** die Klebmassenversorgung
 (63) mit einer Vielzahl von Klebmasse führenden
 Rohren (632) ausgestattet ist, und dass jedes der
 Rohre (632) an einen Kanal (633) für die Zustellung
 von Klebmasse zu den jeweiligen Einspritzdüsen
 (622) angeschlossen ist.

8. Haspelmaschine (100) gemäß Anspruch 1, **dadurch gekennzeichnet, dass** die Bahnmateri-
 al-Zustellvorrichtung (4) folgende weiteren Positionen um-
 fasst:

wenigstens eine Gegendruckwalze (4) mit we-

nigstens einem Gegendruckschneidmesser (411); und

wenigstens eine Perforierwalze (42), ausgestattet mit einer Vielzahl von Schneidmessern (421) die in Umfangsrichtung regelmäßig über die Perforierwalze (42) verteilt sind;

dadurch gekennzeichnet, dass das Gegendruckschneidmesser der Gegendruckwalze (41) koordiniert mit den Schneidmessern (421) der Perforierwalze arbeitet, so dass auf dem Bahnmaterial (200) eine Perforationslinie ausgebildet wird.

Revendications

1. Machine à enrouler (100) permettant d'enrouler un matériau en bande, la machine à enrouler (100) comportant :

un réservoir de stockage de tubes centraux (1), qui contient une pluralité de tubes centraux (300) ;

une unité de guidage (2), qui est raccordée au réservoir de stockage de tubes centraux (1) à des fins d'acheminement des tubes centraux (300) un à la fois en provenance du réservoir de stockage de tubes centraux (1) en fonction d'une temporisation prédéterminée et qui a un premier mécanisme de collage (22) à des fins d'injection d'une colle initiale sur les tubes centraux (300) ; un moyen de transmission (3), comportant :

un bras d'alimentation oscillant (31), qui comporte une extrémité fixe (311) et une extrémité de poussée (312) pivotée au niveau de l'extrémité fixe (311), dans laquelle l'extrémité de poussée (312) destinée à pousser le tube central sert à des fins d'oscillation le long d'une première orbite d'oscillation (I) ;

un ensemble de cylindres (32) comportant :

un premier cylindre (321), qui est arrangé à proximité du bras d'alimentation oscillant (31) ;

un second cylindre (322), qui est arrangé sous le premier cylindre (321), et un jeu est formé entre le premier cylindre (321) et le second cylindre (322) au niveau de la première orbite d'oscillation (I) ; et

un troisième cylindre (323), qui est arrangé sous le premier rouleau (321) ; et un mécanisme de guidage roulant (33), qui est arrangé entre le second cylindre (322) et le troisième cylindre (323), et définissant un passage de transport

(34) entre le premier cylindre (321) et le mécanisme de guidage roulant (33) ;

un ensemble d'alimentation de matériau en bande (4), qui est adjacent au moyen de transmission (3) permettant d'alimenter le matériau en bande (200) jusqu'au moyen de transmission (3) ; et

un ensemble de saisie oscillant (5) comportant :

un bras de saisie oscillant (51), qui a une extrémité fixe (511) et une extrémité de saisie (512) pivotée au niveau de l'extrémité fixe (511), l'extrémité de saisie (512) servant à osciller le long d'une seconde orbite d'oscillation (II) ; et

un cylindre de saisie (52), qui est monté sur l'extrémité de saisie (512), dans laquelle une région d'enroulement (53) est définie parmi le premier cylindre (321), le troisième cylindre (323) et le cylindre de saisie (52) ;

lors du fonctionnement, le tube central (300) est alimenté en provenance du réservoir de stockage de tubes centraux (1) jusqu'à l'unité de guidage (2), est enduit de la colle initiale par le premier mécanisme de collage (22) et est transporté jusqu'au moyen de transmission (3) qui pousse le tube central (300) en provenance de l'unité de guidage (2) jusqu'au passage de transport (34), et pendant ce temps, le matériau en bande (200) est alimenté en provenance de l'ensemble d'alimentation de matériau en bande (4), est collé sur le tube central (300) au niveau du passage de transport (34) et est enroulé autour du tube central (300) à des fins de formation d'un tube central de travail (300a), et puis le tube central de travail (300a) est transporté au travers du passage de transport (34) jusqu'à la région d'enroulement (53) et passe à l'enroulement à une vitesse prédéterminée, un nouveau tube central (300) étant alimenté par l'unité de guidage (2) jusqu'au moyen de transmission (3) quand le tube central de travail (300a) termine le travail d'enroulement, et le transport du nouveau tube central (300) au niveau du passage de transport (34) vient gêner la vitesse du matériau en bande (200), ceci entraînant la déchirure du matériau en bande (200) et la production d'un rouleau (400).

2. Machine à enrouler (100) selon la revendication 1, **caractérisée en ce que** l'unité de guidage (2) comporte par ailleurs :

un passage de guidage (21), qui est raccordé au réservoir de stockage de tubes centraux (1)

- à des fins d'acheminement des tubes centraux (300) en provenance du réservoir de stockage de tubes centraux (1) jusqu'au premier mécanisme de collage (22) à des fins d'application de la colle initiale sur les tubes centraux (300) ; et un mécanisme de poussée (23) qui pousse le tube central (300) en provenance du premier mécanisme de collage (22) jusqu'au moyen de transmission (3) une fois que le tube central (300) est enduit de colle initiale. (200).
- 5
10
3. Machine à enrouler (100) selon la revendication 1, **caractérisée en ce que** l'extrémité de poussée (312) du bras d'alimentation oscillant (31) comporte par ailleurs un cylindre de poussée (313). 15
4. Machine à enrouler (100) selon la revendication 1, **caractérisée en ce que** la machine à enrouler (100) comporte par ailleurs un second mécanisme de collage (6) comprenant un couvercle (61), un injecteur (62) et une alimentation en colle (63), qui sont alignés les uns par rapport aux autres et empilés ensemble de haut en bas selon une séquence, le second mécanisme de collage (6) injectant de la colle de fin sur le rouleau (400). 20
25
5. Machine à enrouler (100) selon la revendication 4, **caractérisée en ce que** le couvercle (61) comporte une pluralité d'ouvertures d'injection (611). 30
6. Machine à enrouler (100) selon la revendication 4, **caractérisée en ce que** l'injecteur (62) comporte une pluralité d'aiguilles d'injection (622) situées de manière correspondante sous les ouvertures d'injection (611). 35
7. Machine à enrouler (100) selon la revendication 4, **caractérisée en ce que** l'alimentation en colle (63) comporte une pluralité de tubes (632) contenant de la colle et chacun des tubes (632) est raccordé à une tubulure (633) à des fins d'alimentation de la colle aux aiguilles d'injection (622) correspondantes. 40
8. Machine à enrouler (100) selon la revendication 1, **caractérisée en ce que** l'ensemble d'alimentation de matériau en bande (4) comporte par ailleurs : 45
- au moins un contre-cylindre (41) comportant au moins une contre-lame (411) ; et 50
- au moins un cylindre de perforation (42) comportant une pluralité de lames (421) espacées de manière régulière au niveau de la périphérie du cylindre de perforation (42) ; 55
- caractérisée en ce que** la contre-lame du contre-cylindre (41) fonctionne de manière coordonnée avec les lames (421) du cylindre de perforation (42) à des fins de formation d'une ligne de perforations au niveau du matériau en bande

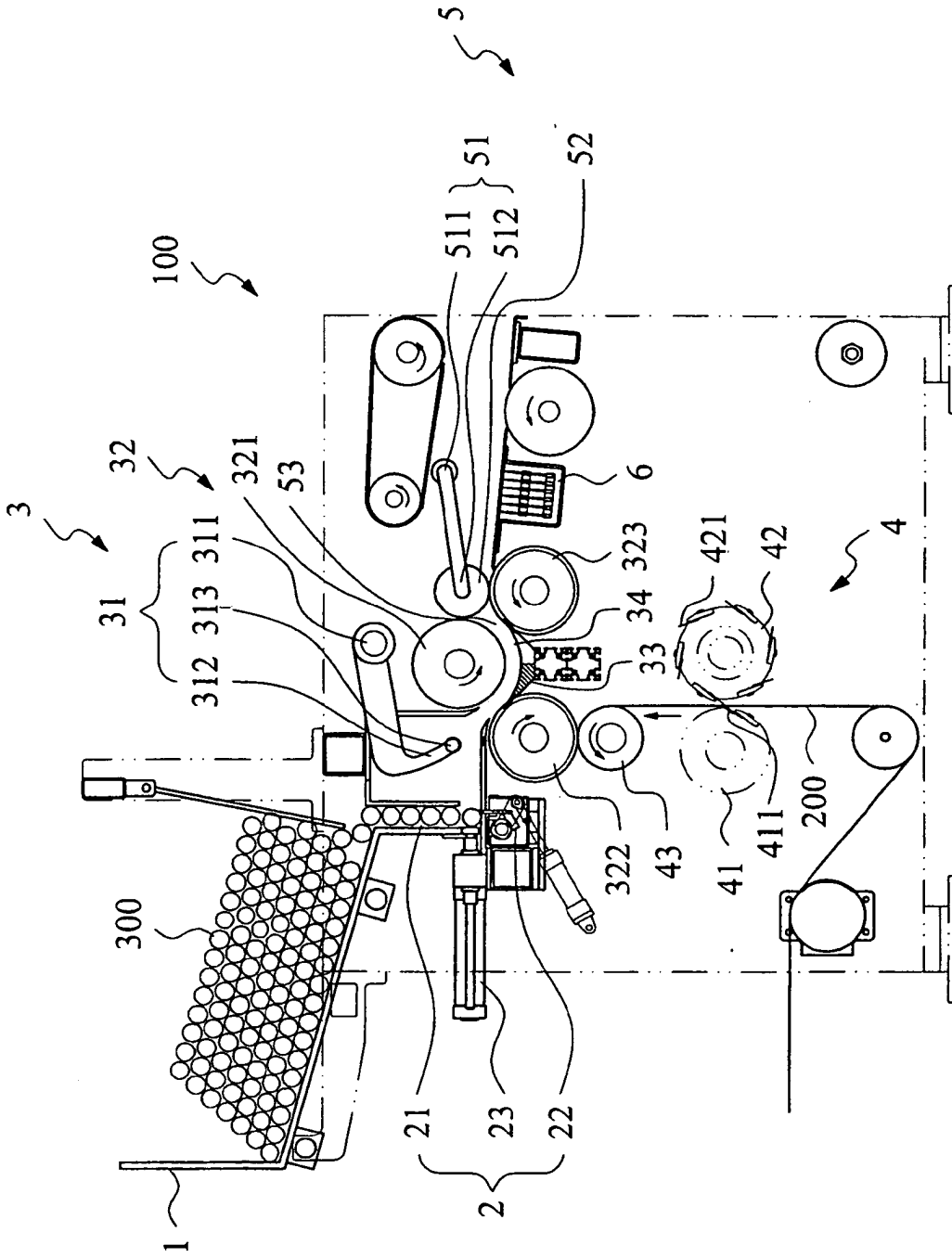

FIG.1

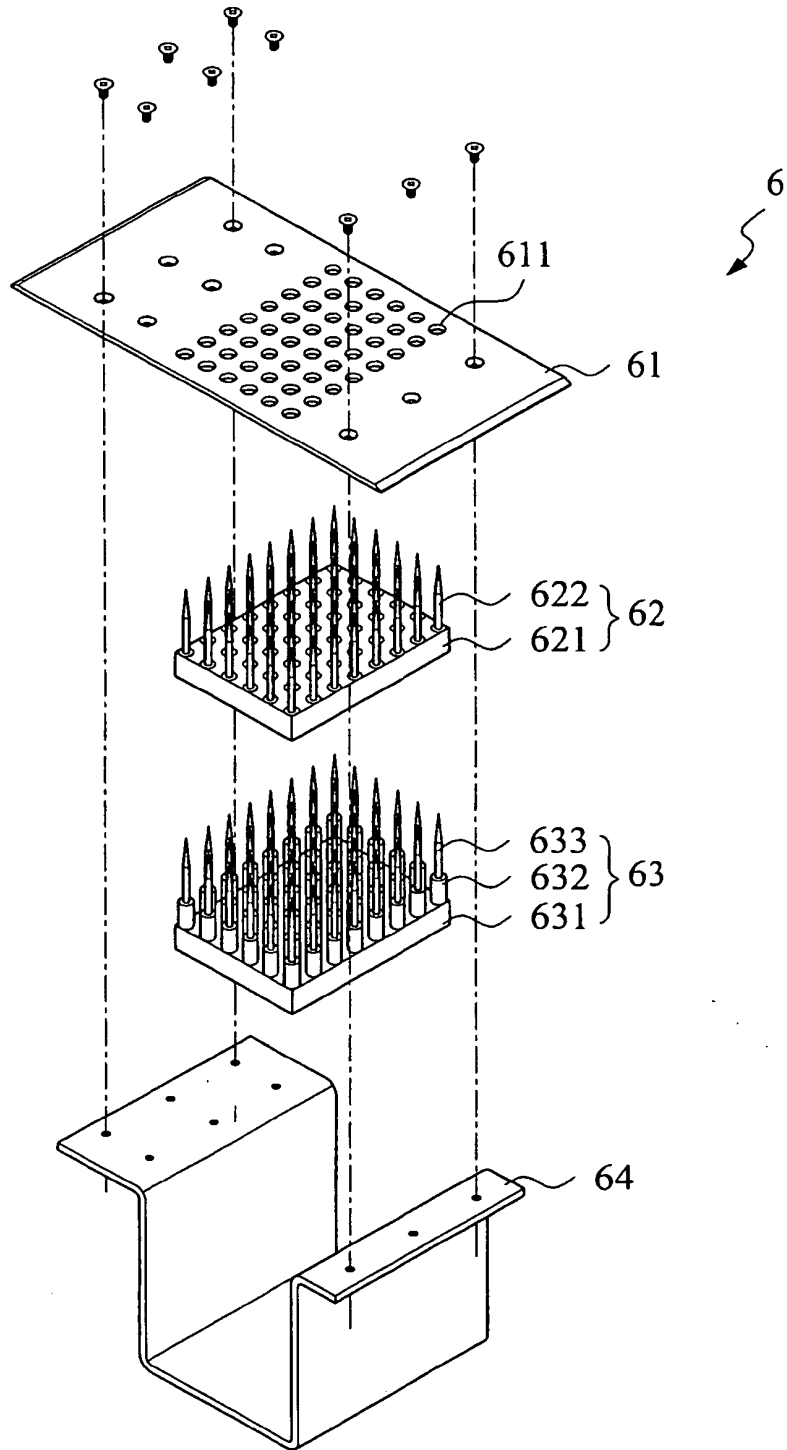

FIG.2

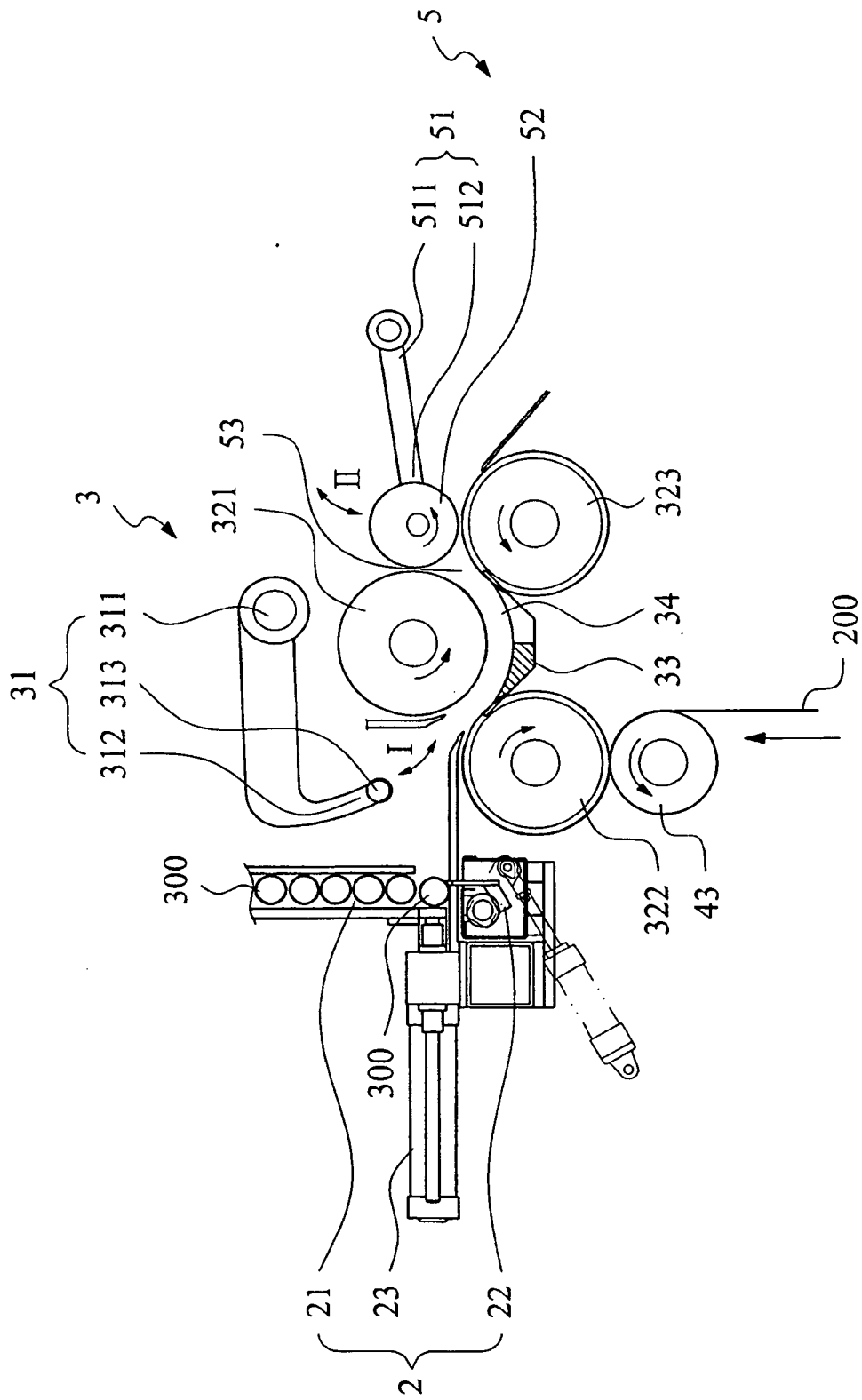

FIG.3

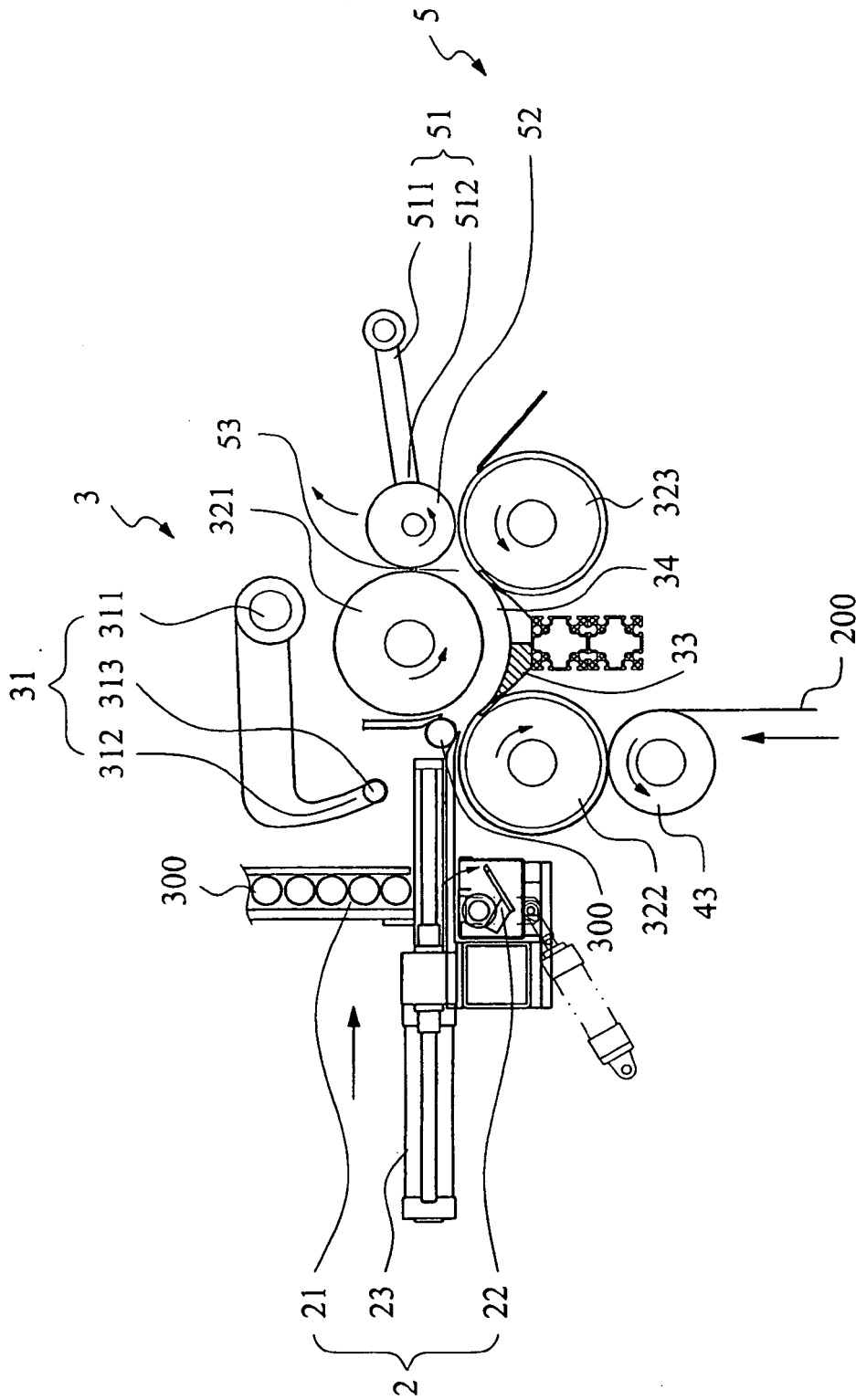

FIG.4

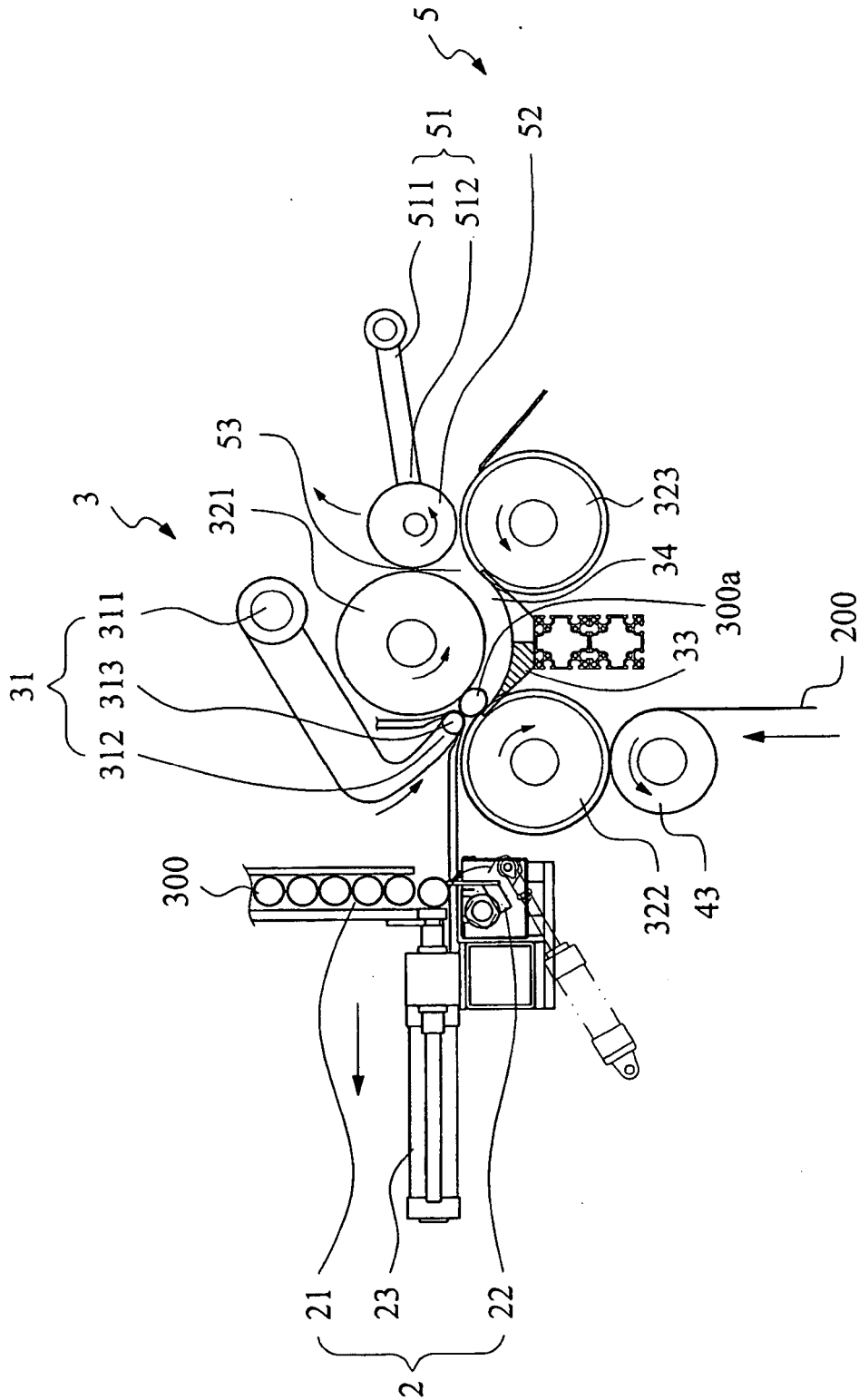

FIG.5

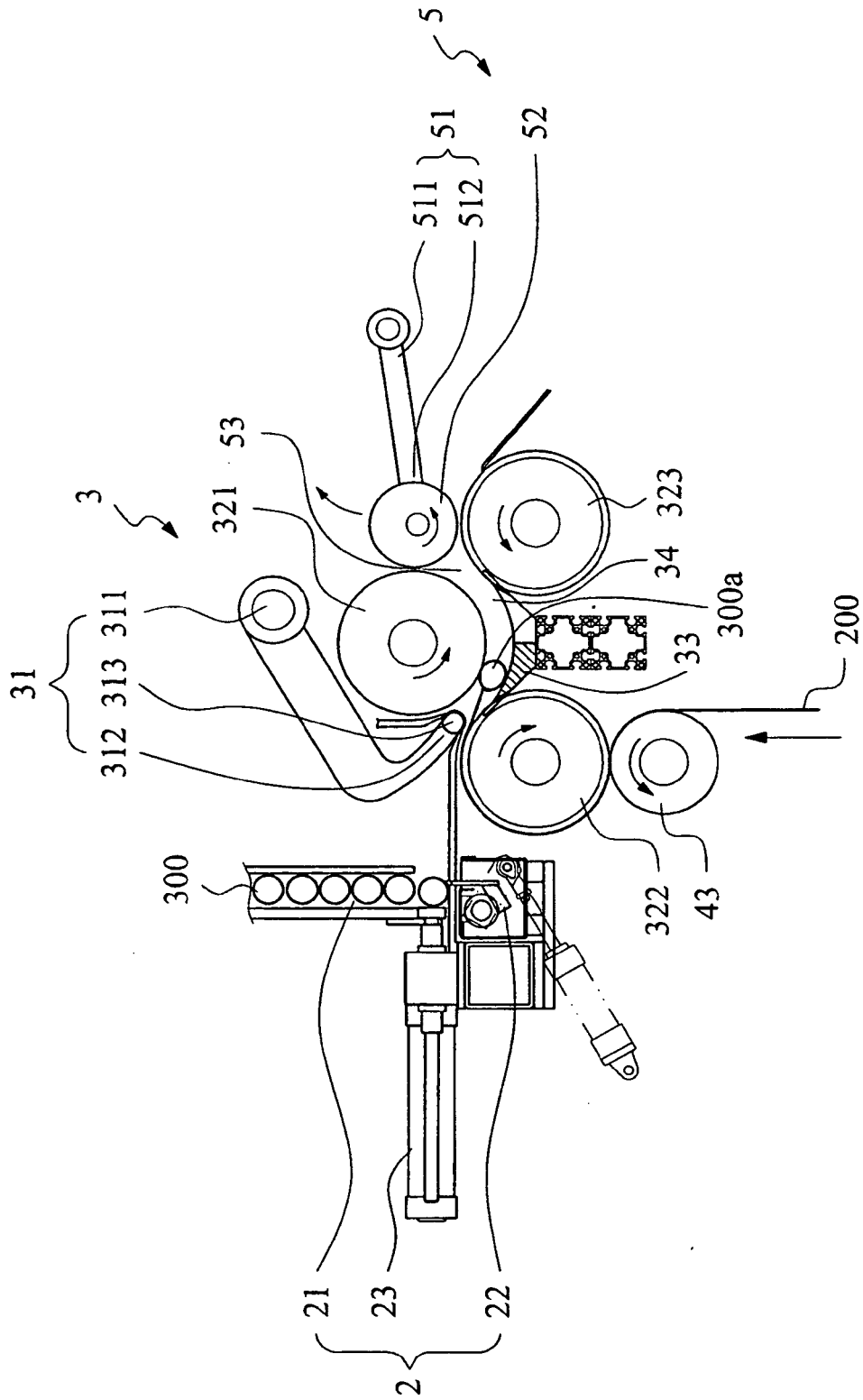

FIG.6

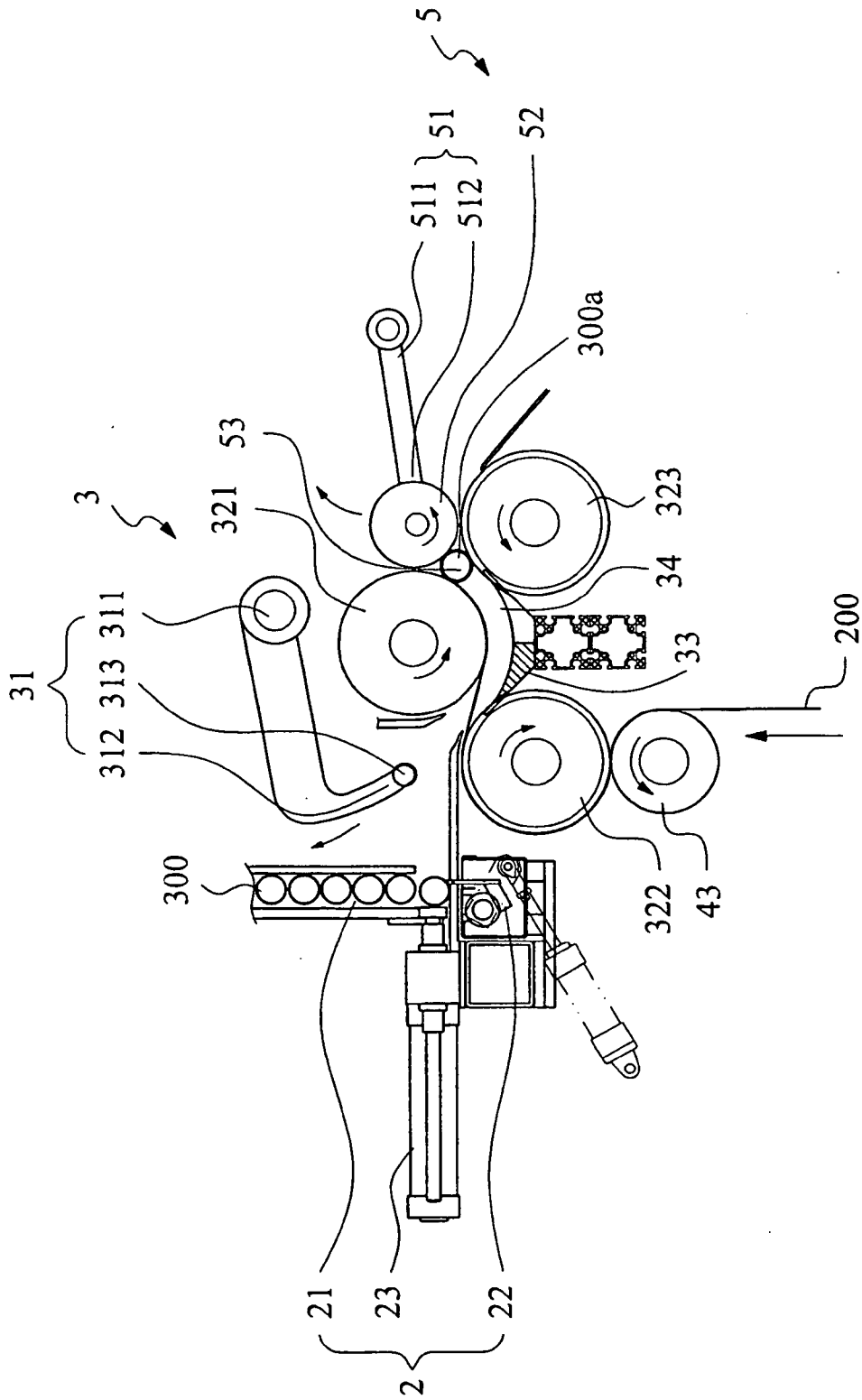

FIG.7

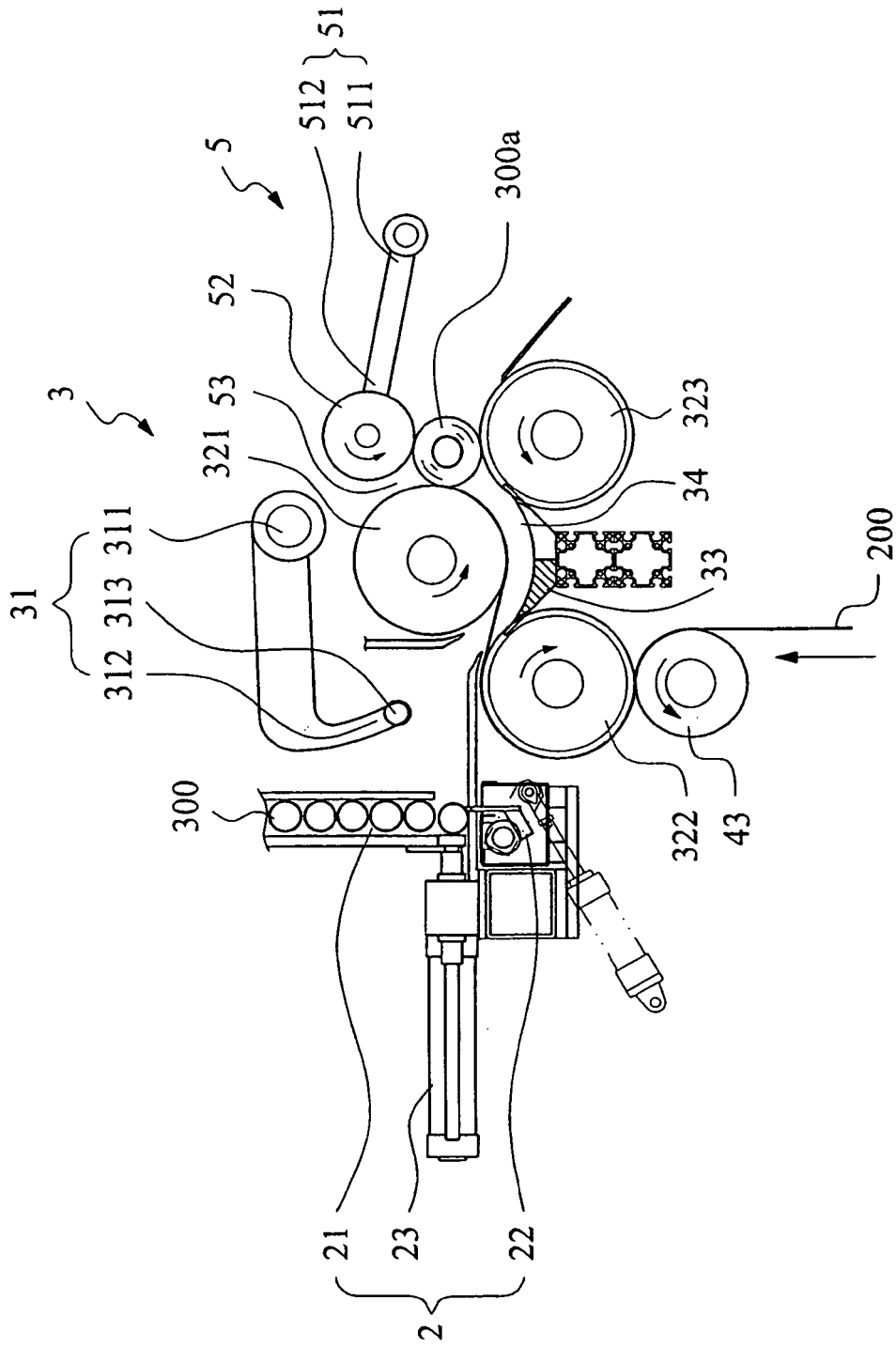

FIG.8

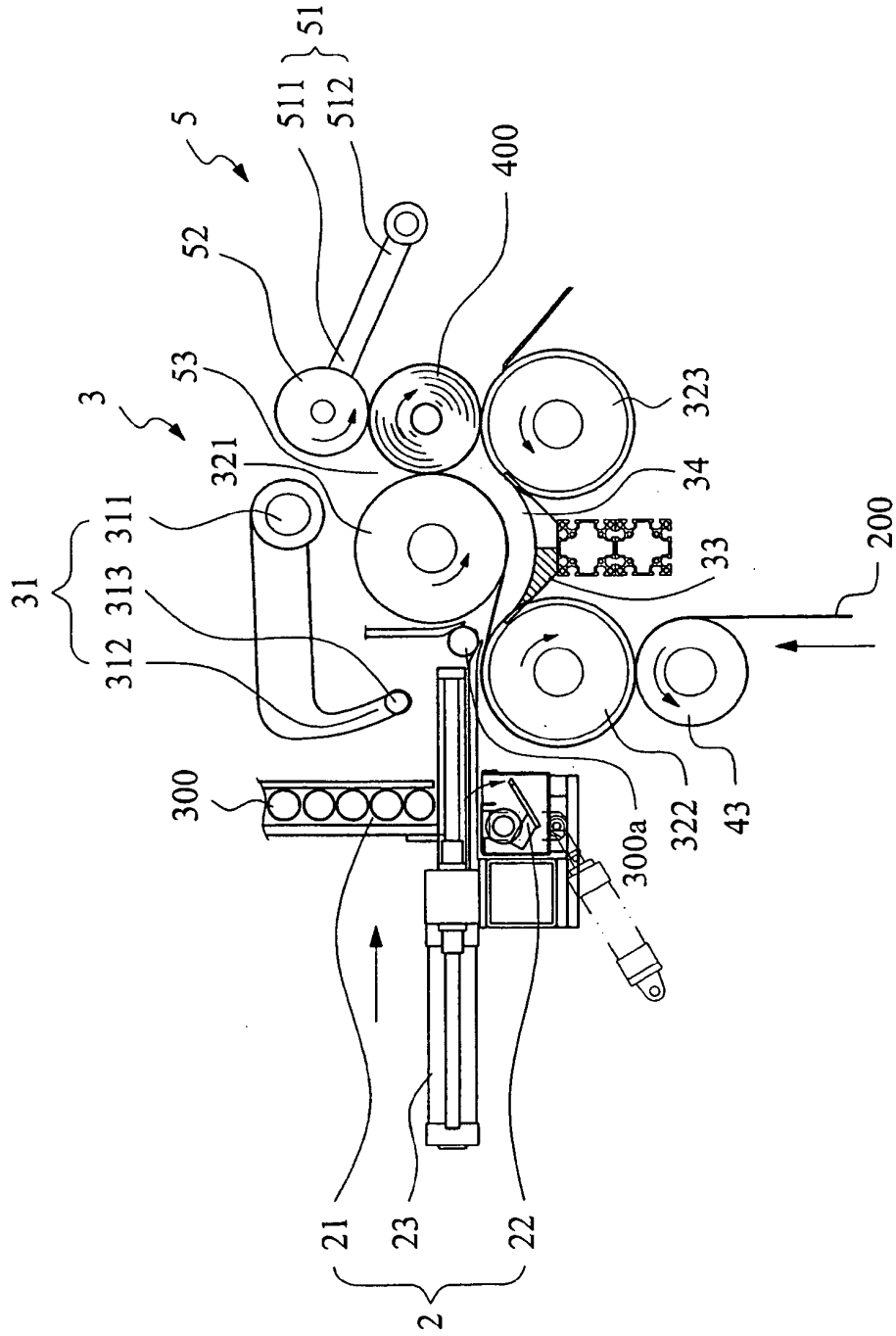

FIG.9

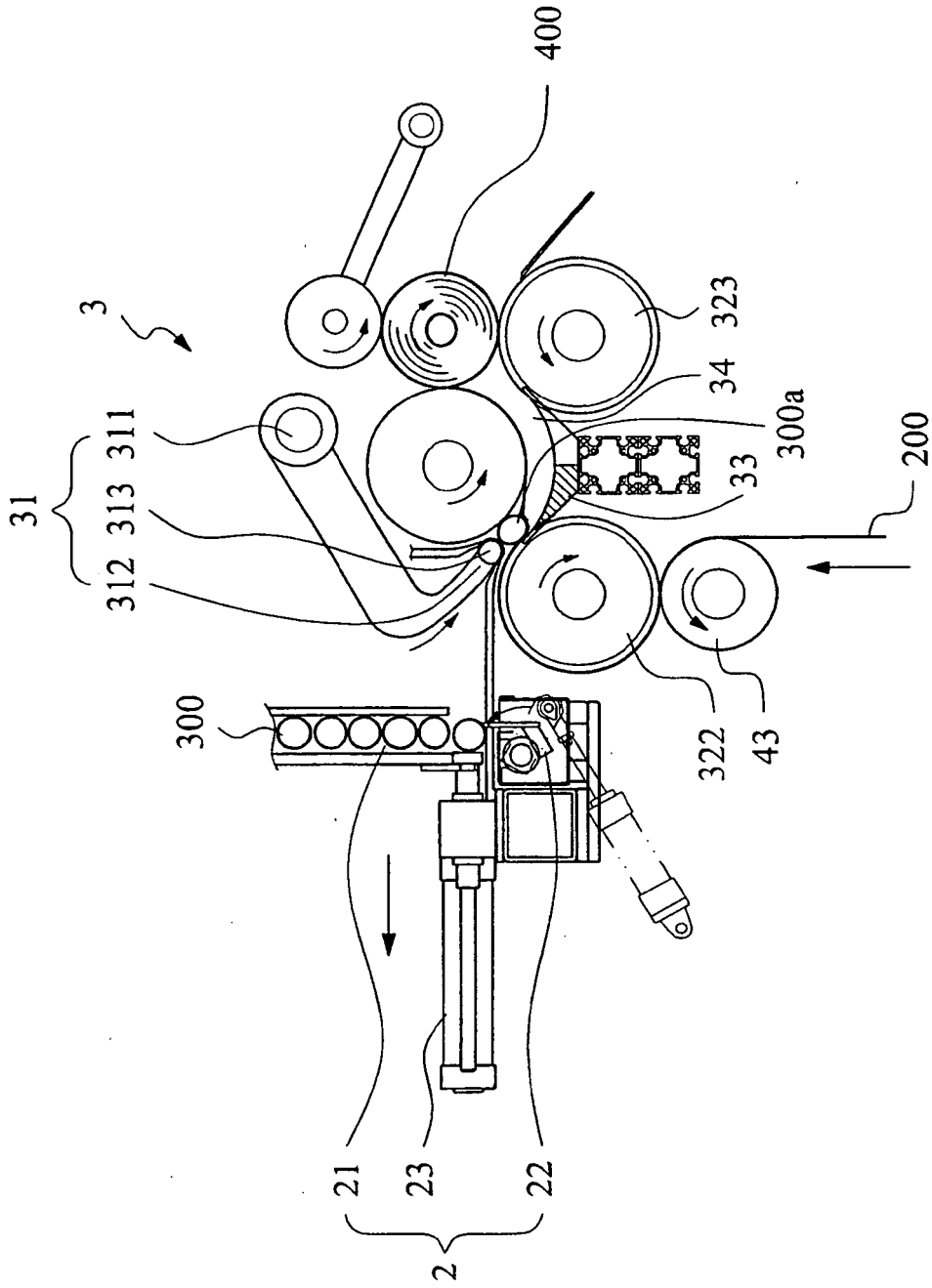

FIG.10

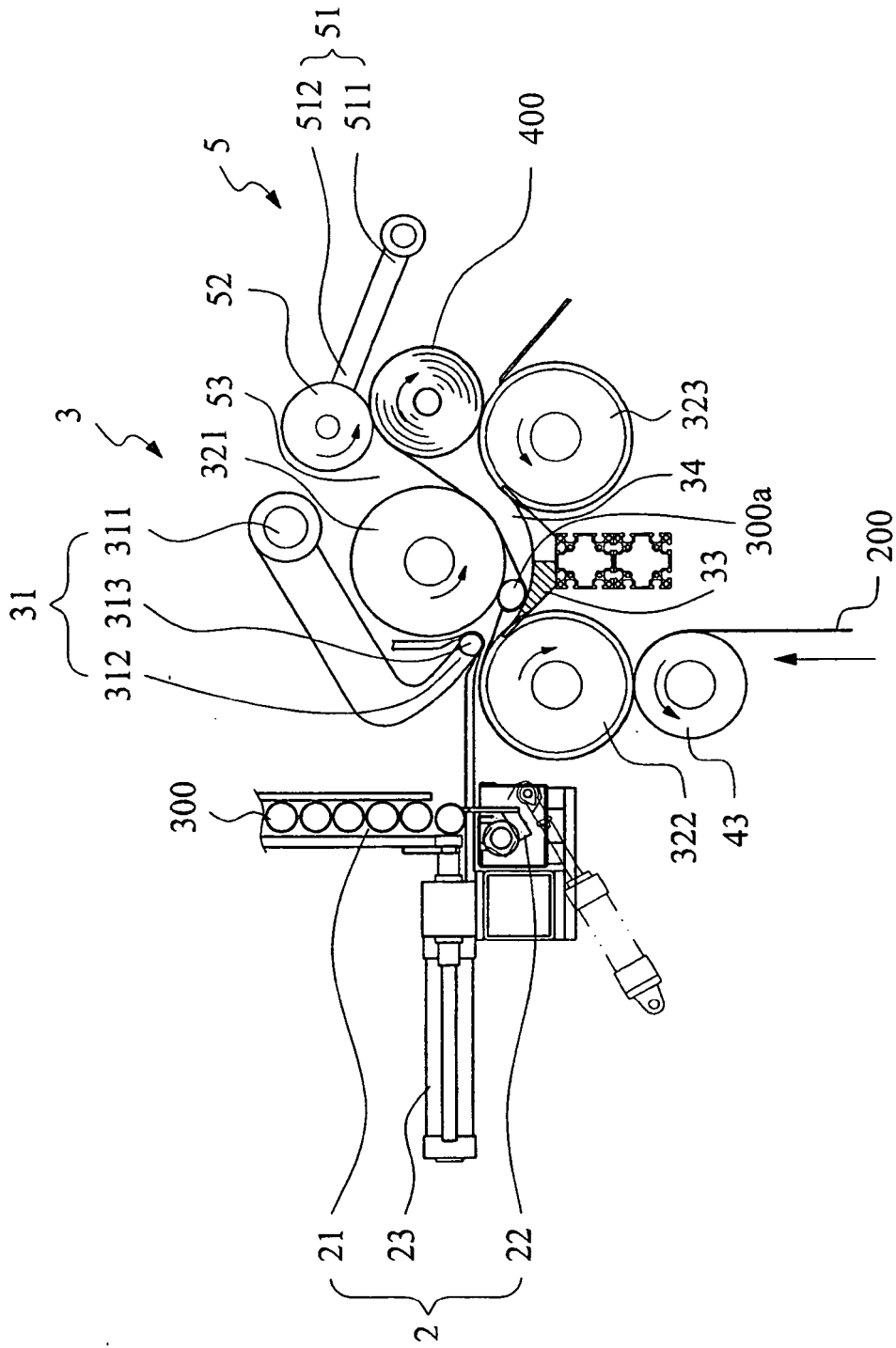

FIG.11

REFERENCES CITED IN THE DESCRIPTION

This list of references cited by the applicant is for the reader's convenience only. It does not form part of the European patent document. Even though great care has been taken in compiling the references, errors or omissions cannot be excluded and the EPO disclaims all liability in this regard.

Patent documents cited in the description

- US 5979818 A [0003]
- WO 0164563 A [0003]