



(12) **DEMANDE DE BREVET CANADIEN
CANADIAN PATENT APPLICATION**

(13) **A1**

(22) Date de dépôt/Filing Date: 2019/10/18

(41) Mise à la disp. pub./Open to Public Insp.: 2020/04/18

(30) Priorité/Priority: 2018/10/18 (US16/163,810)

(51) Cl.Int./Int.Cl. *A63G 31/00* (2006.01)

(71) Demandeur/Applicant:
WHITEWATER WEST INDUSTRIES LTD., CA

(72) Inventeurs/Inventors:
MYRMAN, MARSHALL COREY, US;
KOIDE, BRAD, US;
PHILP, DANNY, CA

(74) Agent: OYEN WIGGS GREEN & MUTALA LLP

(54) Titre : DISPOSITIF DE SURF GONFLABLE ET METHODE
(54) Title: INFLATABLE SURFING APPARATUS AND METHOD

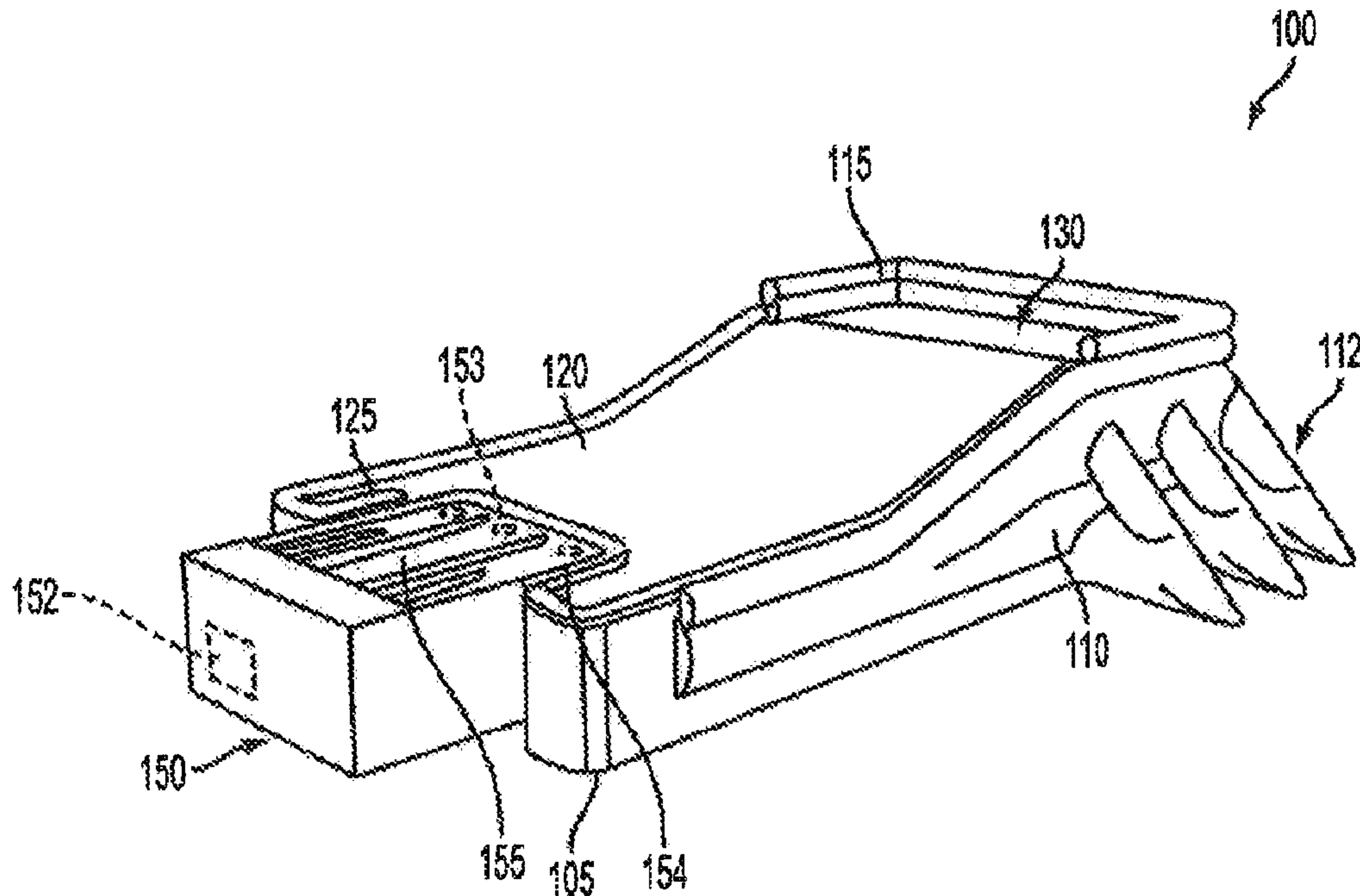

(57) Abrégé/Abstract:

A water or other amusement attraction that includes an inflatable portion or material. A cavity of the attraction is located underneath an upper surface, the upper surface configured to support a flow of water and at least one rider thereon. A volume of water is

(57) **Abrégé(suite)/Abstract(continued):**

configured to be disposed within the cavity, the upper surface floating upon the volume of water while connected to at least one side wall, floor, and/or nozzle structure. A pump and nozzle assembly, positioned outside of the cavity, communicates with the water within the cavity for flowing a portion of the water over the upper surface. A drainage portion, adjacent to the upper surface, drains the flowing water back into the cavity for recirculation. Support components, such as a plurality of beams or an inflatable grid structure help maintain stability for the attraction.

ABSTRACT

A water or other amusement attraction that includes an inflatable portion or material. A cavity of the attraction is located underneath an upper surface, the upper surface configured to support a flow of water and at least one rider thereon. A volume of water is configured to be disposed within the cavity, the upper surface floating upon the volume of water while connected to at least one side wall, floor, and/or nozzle structure. A pump and nozzle assembly, positioned outside of the cavity, communicates with the water within the cavity for flowing a portion of the water over the upper surface. A drainage portion, adjacent to the upper surface, drains the flowing water back into the cavity for recirculation. Support components, such as a plurality of beams or an inflatable grid structure help maintain stability for the attraction.

INFLATABLE SURFING APPARATUS AND METHOD

BACKGROUND

Field

[0001] The present invention relates generally to amusement attractions, such as surfing simulators or other wave machines. More particularly, the present invention relates to mobile or permanently installed water or surfing attractions that incorporate one or more inflatable sections or areas.

Description of the Related Art

[0002] Water attractions (e.g., waterslides, surfing slides or machines, boogie-boarding slides, etc.) are a popular entertainment activity during periods of warm weather. Conventional water attractions are commonly made of fiberglass or other rigid or semi-rigid materials that provide a smooth and slippery surface for supporting a flow of water thereon to transport a rider from an entrance to an exit. A variety of different types of ride vehicles (e.g., inner tubes, body boards, surf boards, floatation devices, etc.) may be used by the rider as the rider travels along the water attraction and support the rider as the ride vehicle slides along the riding surface.

[0003] One type of water attraction that has proven a popular lure for patrons to water or other amusement parks or venues is the surfing machine or simulator. These machines may be used both for entertainment purposes as well as training purposes for helping instruct individuals that may be wary or otherwise unable to surf out in the open ocean. Conventional surf machines utilize water pumps cooperating with nozzles or jets to flow a sheet or layer of water over a variety of surfaces and allow riders to skim atop the water flow. A riding surface of the conventional surf machine is typically a rigid or semi-rigid, low-friction surface that supports

maneuvering by riders upon a conventional or modified surfboard or boogie board (individually and collectively referred to as a “board”). However, users without much surfing experience, either in the ocean or upon surfing machines, commonly fall off of the board during initial attempts at using the surfing machine and the surfaces of these apparatuses can make uncomfortable contact with a rider upon the rider’s falling off of their board.

[0004] Particularly at competition or sports venues (e.g., surfing competitions, BMX competitions, etc.) located outdoors, such as at or near the beach, surfing simulators have increasingly been in demand as a fun and revenue-generating activity for potential patrons. Surfing simulators also provide onlookers with an additional activity to engage in while present at the venue or event. Unfortunately, given the relatively short duration that many competitions extend, some lasting only a few days in duration, permanent installation of surfing simulators at those locations is not feasible. While some mobile surfing simulators have been developed, the comparably long and typically complex assembly and/or disassembly procedures, oftentimes taking greater time than the entire duration of the event itself, makes such devices undesirable to many potential event holders or organizers. These conventional simulators commonly utilize a large number of component parts that require vast numbers of shipment containers for their assembly, adding significantly to the cost associated with transporting and assembling the simulators at a desired geographic location.

[0005] As the sheet flow or standing wave product (collectively “surfing machine”) market becomes more popular, water venues increasingly look to new surfing machines that can provide novel experiences to riders or that are less expensive or time consuming to install. Moreover, as the surfing industry becomes more sophisticated and the influence of extreme sports becomes more popular, more extreme standing waves created by such surfing machines

are desired in order to satisfy the thrill anticipated by these new generation of users, both adults and children alike. As new surfing machines are developed, maneuverability, rider comfort, cost, and efficiency in assembly/disassembly should be adequately addressed and improvements to ensure cost effectiveness, particularly in the mobile water attraction market, is desired. Rider comfort and/or improvements to rider maneuverability would also be desired. Ideally, a mobile surfing simulator would be inexpensive to construct and/or transport, quick and/or easy to assemble and/or disassemble, and would allow a rider to make contact with the surface of the water attraction, for example, upon falling off of a ride vehicle, with minimal discomfort.

SUMMARY

[0006] A water attraction or ride vehicle using inflatable materials is disclosed. In one embodiment, a surfing attraction may include a nozzle for emitting a flow of water, an inflatable ride surface adjacent to nozzle and including a pocket, the ride surface configured to receive the flow of water from the nozzle, an inflatable supporting material positioned beneath the ride surface and configured to have a inclined slope when inflated, an inflatable riser positioned beneath the supporting material and configured to be adjustably inflated for positioning of the ride surface with respect to the nozzle, and a rigid element configured to engage with the pocket of the ride surface, wherein a position of the rigid element is adjustable for maintaining a location of the ride surface with respect to the nozzle.

[0007] In another embodiment, a surfing attraction may include a first inflatable ride surface section, a second inflatable ride surface section positioned adjacent to the first inflatable ride surface section and forming a gap between the first inflatable ride surface section and the second inflatable ride surface section, a protective sheet covering at least a portion of the first

inflatable ride surface section and the second inflatable ride surface section, and a filling element positioned within a gap.

[0008] In still another embodiment, a surfing attraction may include a nozzle for emitting a flow of water, a drainage section for draining the flow of water emitted by the nozzle, the drainage section including a grating having a texture for increasing turbidity of water flowing over the grating, and a ride surface positioned between the nozzle and the drainage section,

BRIEF DESCRIPTION OF THE DRAWINGS

[0009] Other systems, methods, features, and advantages of the present invention will be or will become apparent to one with skill in the art upon examination of the following figures and detailed description. It is intended that all such additional systems, methods, features, and advantages be included within this description, be within the scope of the present invention, and be protected by the accompanying claims. Component parts shown in the drawings are not necessarily to scale and may be exaggerated to better illustrate the important features of the present invention. In the drawings, like reference numerals designate like parts throughout the different views, wherein:

[0010] FIG. 1 shows a perspective view of an inflatable surfing apparatus according to an embodiment of the present invention;

[0011] FIG. 2A shows a front-perspective view of an inflatable surfing apparatus according to an embodiment of the present invention;

[0012] FIG. 2B shows a rear-perspective view of the inflatable surfing apparatus of FIG. 2A according to an embodiment of the present invention;

[0013] FIG. 2C shows an exploded front-perspective view of the inflatable surfing apparatus of FIG. 2 A according to an embodiment of the present invention;

[0014] FIG. 2D shows an exploded rear-perspective view of the inflatable surfing apparatus of FIG. 2 A according to an embodiment of the present invention;

[0015] FIG. 2E shows an exploded top view of the inflatable surfing apparatus of FIG. 2A according to an embodiment of the present invention;

[0016] FIG. 2F shows a side view of a rear end of the inflatable surfing apparatus of FIG. 2A according to an embodiment of the present invention;

[0017] FIG. 3A shows a perspective view of a nozzle and pump assembly for use with an inflatable surfing apparatus according to an embodiment of the present invention;

[0018] FIG. 3B shows a side view of the nozzle and pump assembly of FIG. 3 A according to an embodiment of the present invention;

[0019] FIG. 4A shows a front-perspective view of an inflatable surfing apparatus illustrated from a cut-away view for showing a support structure according to an embodiment of the present invention;

[0020] FIG. 4B shows a rear-perspective view of the surfing apparatus of FIG. 4A according to an embodiment of the present invention;

[0021] FIG. 4C shows a front-perspective view of the surfing apparatus of FIG. 4A with a riding surface connected on top of the support structure according to an embodiment of the present invention;

[0022] FIG. 4D shows a top view of the surfing apparatus of FIG. 4A according to an embodiment of the present invention;

[0023] FIG. 5A shows a perspective view of an inflatable surfing apparatus according to an embodiment of the present invention;

[0024] FIG. 5B shows a perspective view of a dewatering area for use with an inflatable surfing apparatus according to an embodiment of the present invention;

[0025] FIG. 5C shows a perspective view of a pump and nozzle assembly for use with an inflatable surfing apparatus according to an embodiment of the present invention;

[0026] FIG. 6A shows an exploded perspective view of an inflatable surfing apparatus with a protective sheet according to an embodiment of the present invention;

[0027] FIG. 6B shows an exploded rear-perspective view of the inflatable surfing apparatus of FIG. 6 A according to an embodiment of the present invention;

[0028] FIG. 7 shows a perspective view of a bumper under the inflatable base of the inflatable surfing apparatus of FIG. 6 A according to one embodiment of the present invention;

[0029] FIG. 8A shows a perspective view of a vertical wall of the inflatable surfing apparatus according to an embodiment of the present invention

[0030] FIG. 8B shows a perspective view of the vertical wall of FIG. 8A disposed on a riding surface;

[0031] FIG. 9 shows a perspective view of a platform of the inflatable surfing apparatus according to an embodiment of the present invention;

[0032] FIG. 10 shows a side view of a riser for a surfing apparatus according to an embodiment of the present invention;

[0033] FIG. 11 shows a side view of a ride surface for a surfing apparatus positioned via a rigid element cooperating with a pocket according to an embodiment of the present invention;
and

[0034] FIG. 12 shows a side view of a protective sheet for protecting a plurality of ride surface strips for a surfing apparatus according to an embodiment of the present invention.

DETAILED DESCRIPTION

[0035] The detailed description of exemplary embodiments herein makes reference to the accompanying drawings and pictures, which show the exemplary embodiments by way of illustration and its best mode. While these exemplary embodiments are described in sufficient detail to enable those skilled in the art to practice the invention, it should be understood that other embodiments may be realized and that logical and mechanical changes may be made without departing from the spirit and scope of the invention. Thus, the detailed description herein is presented for purposes of illustration only and not of limitation. For example, the steps recited in any of the method or process descriptions may be executed in any order and are not limited to the order presented. Moreover, any of the functions or steps may be outsourced to or performed by one or more third parties. Furthermore, any reference to singular includes plural embodiments, and any reference to more than one component may include a singular embodiment.

[0036] Turning first to FIG. 1, an inflatable surfing apparatus **100** is shown from a perspective view. The surfing apparatus **100** may be configured to be a mobile apparatus that is capable of being transported or shipped from one geographic location to another or may be configured to be assembled in one location where it is designed to permanently reside. The surfing apparatus **100** includes a base **105** that defines at least some of the boundaries for a support structure for supporting various components or surfaces of the surfing apparatus **100**. The base **105** may be anchored to the ground in one embodiment and/or may remain in place due to the total weight of the inflatable surfing apparatus **100**. A riding surface **120** is connected with the base **105** (e.g., at the edges, sides, and/or perimeter of the riding surface **120** in one possible example) and defines a surface that a flow of water may be disposed upon for riders to slide or

surf upon, either with a ride vehicle (e.g., a surfboard, boogie board, inflatable ride vehicle, etc.) or without any ride vehicle, as discussed in greater detail herein. Inflatable contact walls **125** are connected with the riding surface **120** and/or the base **105**, for example, to help maintain water upon the riding surface **120** until the water reaches a designated area or portion of the surfing apparatus **100** (e.g., drains, channels, troughs, or other means for recirculation of the water). For example, the inflatable contact walls **125** may extend an elevation above the riding surface **120** so that water and/or riders encountering the inflatable contact walls **125** are aided to stay upon the riding surface **120**. In an alternative embodiment, if it is desirable for water upon the riding surface **120** to drain from the riding surface **120** laterally, no contact walls **125** may be used.

[0037] A first inflatable wall **110** is connected with the base **105** (and/or potentially the contact walls **125**) and includes extending or protruding portions **112** for helping maintain balance of the surfing apparatus **100**, for example, in an upright orientation. In one embodiment, the contact walls **125** may be a part of the first inflatable wall **110**. A second inflatable wall **115** is connected with the first inflatable wall **110** and/or the base **105**. The first inflatable wall **110** and the second inflatable wall **115** may be made of different materials (e.g., the first inflatable wall **110** may be made of a stronger or less cushioned material in order to better stabilize the surfing apparatus **100**. In an alternative embodiment, the first inflatable wall **110** and the second inflatable wall **115** may be made of the same material or may be the same inflatable wall. Any combination of sectioned walls may be connected to one another and/or to other components to form a structure for supporting a surface that may be ridden by a rider upon a flow of water or a single, non-sectioned structure may be used in different embodiments.

[0038] A pump and nozzle assembly **150** (e.g., discussed in greater detail herein) is connected at a front end of the surfing apparatus **100** and is configured to supply a flow (e.g., a

sheet flow and/or deep flow) of water or other fluid onto the riding surface **120** in a direction leading away from the front end of the surfing apparatus **100** to a back end of the surfing apparatus **100**. A drain portion **130**, located at the back end of the surfing apparatus **100**, drains the water or other fluid after it travels on the riding surface **120**. The pump and nozzle assembly **150** may include one or more pumps **152** that operate to recirculate fluid drained at the drain portion **130** back to nozzles or other fluid-directing elements **153** of the pump and nozzle assembly **150**. These nozzles or other fluid-directing elements **153** provide a predetermined amount, volume, and/or flow of fluid onto the riding surface **120**. In certain embodiments, the amount, volume, or flow of fluid may be variable.

[0039] A cover or planar portion **155** extends over or is connected with the nozzles or other fluid-directing elements **153** of the pump and nozzle assembly **150**, for example, to help prevent riders on the riding surface **120** from getting too close and/or colliding or interfering with the nozzles or other fluid directing elements **153**. This cover or planar portion **155** may be rigid or semi-rigid, and/or may be made or covered with a padded or soft material to aid in rider comfort in case of a collision therewith. The nozzles or other fluid-directing elements **153** may be disposed or connected adjacent to a bottom surface **154** of the cover or planar portion **155** and near the front side of the riding surface **120** for flowing the flow of water onto the riding surface **120**. In an alternative embodiment, the cover or planar portion **155** may be any of a variety of shapes or dimensions as desired and/or the nozzles or other fluid-directing elements **153** may be disposed in any of a variety of numbers or positions in order to flow fluid onto the riding surface **120** as desired for a particular ride application.

[0040] Thus, as shown, water (or any other fluid) is configured to flow from the nozzles or other fluid-directing elements **153** at the front end of the surfing apparatus, onto the riding

surface **120**, which may include a sloped (e.g., upwardly extending planar or curved section) portion that can be ridden or surfed by a rider, and subsequently onto the drain portion **130** where the water is drained and recirculated back to the nozzles or other fluid-directing elements **153** via the one or more pumps **152** for repeated flow onto the riding surface **120**. The drain portion **130** drains the water into a cavity or reservoir beneath the riding surface **120**, for example, as discussed in greater detail herein. The riding surface **120** and/or the drain portion **130** may be configured to float upon the body of water in the cavity. In certain embodiments, the riding surface **120** and/or drain portion **130** may be attached to the base **105**, inflatable walls (**110**, **115**), and/or other components of the surfing apparatus **100** (e.g., a structure holding or connected with the nozzles or other fluid directing elements **153**) for stabilizing and/or maintaining the floating riding surface **120** and/or drain portion **130** in a desired position or orientation with one another. In one embodiment, the reservoir cavity may be capable of holding 54,000 liters of fluid.

[0041] Any of a variety of portions (e.g., any or all of the components making up the support and riding surfaces) may be inflatable. For example, the base **105**, first inflatable wall **110**, second inflatable wall **115**, riding surface **120**, and inflatable contact walls **125** may all be fully inflatable. In an alternative embodiment, any of these components may not be inflatable or may only be partially inflatable (e.g., the riding surface may merely be a fiber, mesh, membrane, etc. material attached, stretched, and/or tensioned as desired, but not comprising an inflatable surface and/or may have certain portions configured to inflate and other portions that do not inflate). Additional or fewer elements or components may be added or removed from the surfing apparatus **100** in an alternative embodiment. Alternative embodiments may utilize modified or different shapes, sizes, or configurations other than that explicitly illustrated in the embodiment

of FIG. 1 and other types of fluid or lubrication for sliding a rider on the riding surface **120** may be used (e.g., snow, air, etc.).

[0042] In one embodiment, the riding surface **120** and/or other surfaces (e.g., inflatable components) of the surfing apparatus **100** may be formed of a drop-stitch material. Drop-stitch material may allow such surfaces to be safe and flexible when accommodating riders or other load-bearing elements, but without tensioning. The surfing apparatus **100** may be modular such that various components can be easily connected or attached to other components (e.g., inflatable slides or other amusement features may be attached to the surfing apparatus **100** to create a larger or more varied amusement or play structure). For example, various padding or pillowed elements may be connected in a modular fashion to form a recovery system for maintenance of a rider within a desired area of the surfing apparatus **100**. In this fashion, if a rider falls off their surfboard, boogie board, or other ride vehicle, or otherwise loses control when using the surfing apparatus **100**, rider comfort may be increased in the case of a contact with a surface of the surfing apparatus **100**. Any of a variety of additional or alternative parts may be used in conjunction with the illustrated components of FIG. 1 and made of inflatable material, partially inflatable material, or a non-inflatable material, for example side closures, transition pads between riding surfaces or other components of the surfing apparatus **100**, nozzle flaps, etc.

[0043] Turning next to FIG. 2A, a front-perspective view of a surfing apparatus **200** is shown. FIG. 2B shows the surfing apparatus **200** but from a rear-perspective view. The surfing apparatus **200** may include features that are the same as or similar to the surfing apparatus **100**, previously discussed. The surfing apparatus **200** includes a base **205**, a wall **210**, a riding surface **220**, drainage surface **230**, stairs **240**, and a pump/nozzle assembly **250**. Similar to the operation previously described for FIG. 1, water flows from the pump/nozzle assembly **250** onto the riding

surface **220**, and then onto the drainage surface **230** where it is drained (e.g., by falling through a porous surface of the drainage surface **230**, for example, as illustrated) to a water reservoir or cavity disposed under the riding surface **220** (e.g., formed by the base **205**) so that the water may be recirculated and re-introduced to the riding surface **220** by the pump/nozzle assembly **250**. The riding surface **220** may be connected to the base **205** and/or the wall **210** at least partially along its perimeter while configured to float upon the water in the water reservoir.

[0044] The stairs **240** may be formed of a rigid or semi-rigid material (e.g., inflatable, partially inflatable, or non-inflatable) and include sidewalls **245** (e.g., inflatable, partially inflatable, or non-inflatable) to help prevent a rider from falling off the side of the stairs **240** when ascending or descending. The base **205** may be inflatable and include extending or protruding portions **207** to aid in supporting the surfing apparatus **200** in the desired, upright orientation when inflated. A platform **262** is disposed adjacent to the pump/nozzle assembly **250** and configured to fit beneath a portion of the pump/nozzle assembly **250** for providing a surface for the portion of the pump/nozzle assembly **250** to mate therewith and/or flow water thereon from the pump/nozzle assembly **250** before the water flows onto the riding surface **220**. Drains **260** are positioned on either side of the platform **262** to drain water that is not desirably transmitted onto the riding surface **220** from the pump/nozzle assembly **250** back to the water reservoir.

[0045] FIG. 2C shows the surfing apparatus **200** from the front-perspective view, but with certain of the components or parts in an exploded configuration. Similarly, FIG. 2D shows the surfing apparatus **200** from the rear-perspective view, but with certain of the components or parts in an exploded configuration. As illustrated, various separate components make up the surfing apparatus **200** and are configured to connect or assemble together (e.g., by adhesives,

bolts, clips, straps, etc.). Certain of these components include the pump/nozzle assembly **250**, the base **205**, the wall **210**, the riding surface **220**, the drainage surface **230**, the stairs **240**, and the sidewalls **245** for the stairs **240**. A surrounding contact wall or lip **215** extends around at least a portion of the perimeter of the drain surface **230** and the riding surface **220**, for example to help keep riders and/or water within a desired area or portion of the surfing apparatus **200** and/or to close a gap between the riding surface **220** and the wall **210**. The base **205** is made up of at least four parts, as shown, that fit together with one another and/or with other components of the surfing apparatus **200** (e.g., the wall **210**). Similarly, the wall **210** is made up of at least three parts, as shown, that fit together with one another and/or with other components of the surfing apparatus **200**.

[0046] In the exploded configurations shown by FIGS. 2C-2D, an inflatable bottom surface **280** and a supporting inflatable structure **270** is viewable. The inflatable bottom surface **280** is configured to rest on the ground and may be part of the base **205** in certain embodiments. The supporting inflatable structure **270** is configured to float upon a body of water between it and the inflatable bottom surface **280**. In some embodiments, the supporting inflatable structure may be anchored to the bottom surface **280** and/or other components of the surfing apparatus **200**. Both the inflatable bottom surface **280** and the supporting inflatable structure **270** are located beneath the riding surface **220** and/or drainage surface **230** and act to support and/or stabilize the surfing apparatus in a desired, upright orientation such that the riding surface **220** can be ridden by riders. An area between the bottom surface **280** and the supporting inflatable structure **270** forms the water reservoir or water tank for the recirculation of water during operation. In one embodiment, a layer of material **272** (e.g., drop stitch material) may be disposed between the supporting inflatable structure **270** and the riding surface **220**. The

inflatable structure **270** and/or layer of material **272** may extend so as to fully cover the bottom surface **280** or reservoir formed as part of the surfing apparatus or may only cover a portion of the bottom surface **280** or reservoir.

[0047] FIG. 2E shows an exploded top view of the inflatable surfing apparatus **200** of FIG. 2A. The base **205** may be made up of separate components such that, when assembled, the surfing apparatus has an overall rectangular configuration being approximately **1256.7cm** in length **291** and **595cm** in width **292**. Each of the extension elements **207** of the base **205** may be **48cm** in width **293**. The stairs **240** may be **86.3cm** in width **294** and **147.3cm** in total width **295** when combined with the two sidewalls **245**. The drainage surface **230** may extend for **400cm** in length **296** from a rear end of the ride until the beginning of the riding surface **220**. As shown, the pump/nozzle assembly **250** may be **207cm** in width **297** while the width of the riding surface **220** may be **456cm** wide **298**. In an alternative embodiment, any of a variety of desired dimensions, configurations, or shapes may be used for the design of the surfing apparatus **200**.

[0048] FIG. 2F shows a side view of a rear end of the surfing apparatus **200** of FIG. 2A. In one embodiment, the complete width **285** of the surfing apparatus **200** (e.g., made up of various connectible base **205** elements) may be approximately **957.4cm**. A height **286** from the ground to the top of the wall **210** may be **322cm**. The width **287** of the rear portion of the wall **210** may be **595cm**. A height **288** from the ground to the top of the linearly-inclined portion of the stairs **240** may be **266cm**. In an alternative embodiment, any of a variety of desired dimensions, configurations, or shapes may be used for the design of the surfing apparatus **200**.

[0049] FIGS. 3A and 3B show a perspective view and a side view, respectively, of a pump and nozzle assembly **300** for use with an inflatable surfing apparatus. The surfing apparatus and/or the pump and nozzle assembly **300** may include features or aspects that are the

same as or similar to those previously discussed. The pump and nozzle assembly **300** includes a connector **322** disposed within a container or tube **320** for the purpose of receiving and flowing a fluid (e.g., water) within the container or tube **320** for distribution onto a riding surface of the surfing apparatus. The connector **322** is configured to connect with a suction inlet **310**. A pump (e.g., located in the container or tube **320**) is configured to pump the fluid (e.g., water from a water reservoir that is disposed under the riding surface of the surfing apparatus) through the connector **322** and the container or tube **320**. In an alternative embodiment, part or all of the pump may be disposed in alternative locations for pumping or otherwise pressurizing fluid so that it flows through the container or tube **320**.

[0050] A back portion **330** of the pump and nozzle assembly **300** includes a curved segment **335** wherein the fluid flows within from the connector **322**, through the container or tube **320**, and to a planar portion **340** of the nozzle assembly. One or more nozzles or other fluid-directing elements may be disposed within or connected with the planar portion **340**, for example as previously discussed, for directing the fluid onto an adjacent riding surface at a desired velocity, flow rate, or orientation, etc. The planar portion **340** may be configured to connect or otherwise be disposed adjacent to the riding surface of the surfing apparatus (e.g. centered along a width of the riding surface). The pump and nozzle assembly **300** may be configured to interface or connect with an inflatable attraction from outside of the inflatable attraction, for example, in a modular nature.

[0051] Turning next to FIG. 4A, a front-perspective view of a surfing apparatus **400** illustrated with a cut-away perspective for showing a support structure therein is shown. Similarly, FIG. 4B shows a rear-perspective view of the surfing apparatus **400** illustrated with a cut-away perspective. The surfing apparatus **400** and/or the support structure may include

features or aspects that are the same as or similar to those previously discussed. As shown, a base **405** defines at least part of an outer wall or boundary for the surfing apparatus **400** and a support structure having various components is disposed therein, discussed in greater detail below. A floor **480** makes up a bottom surface of the surfing apparatus **400** and may be made of any of a variety of inflatable or non-inflatable materials. A plurality of beams or columns **460** are located on the floor **480** (e.g., secured or otherwise connected with the floor **480**) and extend upward towards an upper surface (e.g., a riding surface) of the surfing apparatus **400**. The plurality of beams **460** may provide support for the upper surface such that a rider can ride upon a flow of water on the upper surface.

[0052] An inflatable structure **470** is disposed on top of certain of the plurality of beams **460** and provides a stable structure for supporting riders as they enter or exit the surfing apparatus **400** while also providing a porous structure for water to drain through after the water flows across the upper surface of the surfing apparatus **400**. Thus, after draining through the inflatable structure **470**, the water arrives in a water reservoir **430** or cavity formed via the base **405**, the floor **480**, and underneath the inflatable structure **470** and upper surface (e.g., riding surface) of the surfing apparatus **400**. When water is within the water reservoir **430** it may be pumped through a suction inlet **410** and directed via nozzles in a pump and nozzle assembly **450** back to a riding or upper surface of the surfing apparatus **400**. As shown in FIG. 4B, a grating **412** may be located at an opening of the suction inlet **410** in order to help prevent foreign objects in the water from getting sucked into the suction inlet and/or pump and nozzle assembly **450**.

[0053] A plurality of attachment mechanisms **462** are disposed in the base **405**, inflatable structure **470**, and/or beams **460** that are configured to connect with a plurality of stabilizing elements (**464**, **466**) that extend between attachment mechanisms **462** on opposite sides of the

surfing apparatus 400. For example, the attachment mechanisms 462 may be openings in the base 405 and the stabilizing elements (464, 466) may be rigid rods that are received by the openings. Certain of the stabilizing elements (464, 466) may be configured to engage with one or more beams 460 or other components of the surfing apparatus 400 (e.g., the inflatable structure 470) in order to stabilize multiple components of the surfing apparatus 400 together. Certain of the stabilizing elements may cross one another at a perpendicular orientation, or may be positioned as parallel elements, as illustrated. In an alternative embodiment, any number of stabilizing elements (464, 466) and/or attachment mechanisms 462 may be used, in any of a variety of positions or orientations.

[0054] FIG. 4C shows a front-perspective view of the surfing apparatus 400, but is illustrated with the upper surface 420 (e.g., a riding surface) connected on top of certain of the plurality of beams or columns 460. The upper surface 420 may be a low-friction material that is connected to an inflatable pad 421 or other surface, the inflatable pad 421 making contact with certain of the plurality of beams 460. As shown, the inflatable pad 421 may vary in thickness as it extends from a rear of the surfing apparatus 400 to a front of the surfing apparatus 400. For example, a rear portion 422 of the inflatable pad 421 may be thicker than a front portion 424 of the inflatable pad 421. In this manner, riders may carve or ride on a surfboard, boogie board, etc. upon a flow of water traveling from the front portion 424 towards the rear portion 422 of the upwardly sloping upper surface 420. The inflatable pad 421 may be shaped with ridges or other dimensions such that it imparts a force upon the upper surface 420, for example, to cause a desired waveform when water is flowing over the upper surface 420. In certain embodiments, the inflatable pad 421 may have separate inflatable compartments such that only desired portions of the inflatable pad 421 (e.g., certain of the inflatable compartments) are inflated. In this fashion,

varying shapes can be imparted upon the upper surface **420** by selectively inflating desired portions of the inflatable pad **421**. Such functionality allows a variety of potential waveforms on the upper surface **420** merely by inflating or deflating portions of the inflatable pad **421**.

[0055] In an alternative embodiment, the inflatable pad **421** may not be inflatable and/or may be disposed with other thicknesses (e.g., a constant thickness) or configurations. For example, to generate alternative water flow paths, the inflatable pad **421** and/or upper surface **420** may be configured or oriented to have ridges, valleys, or other shapes in other locations from those explicitly illustrated to create desired waveforms or water-flow characteristics. In still another embodiment, the inflatable pad **421** and/or upper surface **420** may be configured to be modular and/or easily replaceable such that a ride operator can quickly and/or easily alter the surfing apparatus **400** to have different surfing waveform characteristics.

[0056] FIG. 4D shows a top view of the surfing apparatus **400** illustrated with the upper surface **420**. For example, a rearward part of the base **405** may be **592.1**cm in width **431** while a sideward part of the base **405** may be **1255.1**cm in total width **432**. The base **405** is also shown as having a plurality of extending or protruding arms **407** to aid in the stability of the surfing apparatus **400**. A staircase **490** of the surfing apparatus **400** may have a total width **433** of **153**cm, a plurality of sidewalls **492** of the staircase **490** each being **30.5**cm wide **434**. A drainage surface **495** is also shown adjacent to the upper surface **420**, the same as or similar to previous discussions, for draining water to the water reservoir **430** (see FIGS. 4A-4B) after the water flows off of the upper surface **420**. A sidewall width **435** may be **22**cm, a protrusion width **436** may be **46**cm, a base width **437** may be **94**cm, a drain width **438** may be **140** cm, and a pump and nozzle assembly width **439** may be **220**cm. In an alternative embodiment, any of a variety of dimensions, widths, lengths, etc. may be used for various component parts.

[0057] Turning next to FIG. 5A, a perspective view of an inflatable surfing apparatus **500** is shown. The surfing apparatus **500** may include features or aspects that are the same as or similar to those previously discussed. The surfing apparatus **500** is configured to be a mobile or portable ride attraction and fits, when disassembled, within one or more containers **505** for shipment. The container **505** serves a second purpose for housing filtration units, piping or plumbing, electronic controls, etc. for the surfing apparatus **500** when the surfing apparatus **500** is assembled and operational. Thus, as shown, the container **505** may house such components and may be connected at a rear end of the surfing apparatus **500** during use and connect with other components of the surfing apparatus **500** through a backwall of the surfing apparatus **500**.

[0058] The surfing apparatus **500** includes an inflatable structure **515** making up one or more walls or exterior surfaces. In an alternative embodiment, protruding elements or arms (not shown) may extend from the inflatable structure **515** on any side of the inflatable structure **515** in order to provide increased stability, balance, or support for the surfing apparatus **500** during use. A riding surface **520** connects with the inflatable structure **515** and provides a surface upon which a rider may surf, skim, or otherwise ride, either with a ride vehicle, such as a surfboard, or without a ride vehicle. In one embodiment, the riding surface may be a sheet or other fabric or material that is tensioned across or otherwise attaches to the inflatable structure **515**.

[0059] Two layers of material are located beneath the riding surface **520**. A first layer **545** may be a thin layer (e.g., 8 cm thick) of material. In one embodiment, the first layer **545** may be a drop stitch material that inflates flat. A second layer **550** may be a layer with a varying thickness (e.g., thicker near a rear portion of the surfing apparatus **500** and thinner near a front portion of the surfing apparatus **500** in order to provide an inclined shape for the riding surface **520**. In one embodiment, the second layer **550** may be a non-drop stitch inflatable material. A

dewatering area **530** is located adjacent to the riding surface **520** for draining water that flows across the riding surface **520** from a pump and/or nozzle assembly **555** to a water reservoir located beneath the dewatering area **530** and/or riding surface **520**. In one embodiment, the riding surface **520**, the first layer **545**, and/or the second layer **550** may be configured to float upon a body of water that is contained within the reservoir located beneath the dewatering area **530** and/or riding surface **520**.

[0060] A plurality of cylinders or columns **540** are located underneath the second layer **550** and operate to support the second layer **550**, the first layer **545**, the riding surface **520**, and/or the dewatering area **530**. One or more of the plurality of cylinders **540** may be configured to be anchored to the inflatable structure **515** via straps **516**. In one embodiment, the straps **516** may be heat-welded vinyl that secures to the inflatable structure **515** and/or the cylinder **540**. In one embodiment, the plurality of cylinders **540** may be PVC pipes. The plurality of cylinders **540** may be configured to be filled with water (e.g., water that is circulated through the water reservoir). For example, each of the plurality of cylinders **540** may be covered such that water is contained therein or each of the plurality of cylinders **540** may be uncovered and/or have one or more holes disposed therein so that water in the water reservoir is capable of flowing into and/or out of each of the plurality of cylinders **540**.

[0061] A staircase **525** may be formed as part of the inflatable structure **515** or connected to the inflatable structure **515** for allowing riders to enter and/or exit the riding surface **520**. In an alternative embodiment, the staircase **525** and/or additional staircases or other entry or exit means (e.g., slides, ladders, etc.) may be disposed at any desired location to permit entrance or exit by riders (e.g., near the pump and/or nozzle assembly **555**).

[0062] FIG. 5B shows a perspective view of a dewatering area **560** for use with an inflatable surfing apparatus (e.g., the surfing apparatus **500** of FIG. 5A). The dewatering area **560** may include features or aspects that are the same as or similar to those previously discussed. The dewatering area **560** includes an inflatable portion **565** (e.g., the second layer **550** of FIG. 5A) and a plurality of gratings **570** that permit water or other fluid to drain through gratings **570** and through or past the inflatable portion **565** to a water reservoir. A pad or mat **580** is disposed on top of at least a portion of the gratings **570** and/or inflatable portion **565**. The pad or mat **580** may or may not be inflatable, but may be soft to provide a more comfortable surface for riders to impact, for example, upon falling or being swept by a flow of water onto the dewatering area **560**. The pad or mat **580** may also be configured to permit water or other fluid to drain therethrough. In an alternative embodiment, the pad or mat **580** may also be disposed at other or additional locations on a surfing apparatus (e.g., adjacent to the pump and/or nozzle assembly **555** of FIG. 5 A).

[0063] FIG. 5C shows a perspective view of the pump and nozzle assembly **555** for use with an inflatable surfing apparatus according to an embodiment of the present invention. The pump and nozzle assembly **555** and/or the inflatable surfing apparatus may include features that are the same as or similar to those previously discussed. The pump and nozzle assembly **555** includes a suction inlet **588** that incorporates a mesh or grating **589** for the suction of water therethrough (e.g., water from a water reservoir of the inflatable surfing apparatus **500**). The mesh or grating **589** may be configured to prohibit foreign objects beyond a predetermined size from being sucked or otherwise enter into the pump and nozzle assembly **555**. In one embodiment, the suction inlet **588** may be made of a steel material. A mounting plate **597** (e.g., made of fiberglass) may be used for securing the suction inlet **588** and/or other components of

the pump and nozzle assembly **585** to the ground, floor, or bottom surface of the surfing apparatus **500**.

[0064] Connected with the suction inlet **588** is a pump tube **587** that houses or otherwise interfaces with pumping equipment for the movement of water from the reservoir, into the suction inlet **588**, and through the pump tube **587**. The pump tube **587** of the pump and nozzle assembly **555** may be configured to be partially submerged (e.g., a portion of the pump tube **587** at an end closest to the suction inlet **588** may be located within a water reservoir of the inflatable surfing apparatus **500** and thus submerged in water while a portion of the pump tube **587** at an end furthest from the suction inlet **588** may be located outside of the water reservoir of the inflatable surfing apparatus **500** and thus not submerged in water.

[0065] As illustrated, a wall of the inflatable surfing apparatus **500** may be configured to extend along a plane **594** and define an opening therein for accommodating the pump tube **587**, thus disposing a portion of the pump and nozzle assembly **555** within **595** the inflatable surfing apparatus **500** and a portion of the pump and nozzle assembly **555** outside **596** of the inflatable surfing apparatus **500**. A sleeve or other gasket may extend around all or a portion of the pump tube **587** within this plane **594** in order to provide a watertight seal such that water cannot leak from the area within **595** the inflatable surfing apparatus to outside **596** of the inflatable surfing apparatus through the opening defined by the wall. In an alternative embodiment, the pump tube **587** may be fully submerged or fully not submerged.

[0066] One or more nozzles **592** are connected to the pump tube **587** via piping or plumbing **598** such that water pumped through the suction inlet **589** is delivered to the one or more nozzles **592** and may then be delivered to a riding surface of the inflatable surfing apparatus. In one embodiment, the one or more nozzles **592** may be connected in a side-by-side

configuration (e.g., extending 2.3 meters in length or less) so as to conveniently fit within a standard shipping container. Cables for providing electrical signals to operate one or more of the components of the pump and nozzle assembly 555 may be connected to motors, generators, computer systems, etc. in order to control the one or more components of the pump and nozzle assembly 555 for providing a desired rate of water flow or quantity of water to a riding surface of the inflatable surfing apparatus. In one embodiment, the cables are not submerged (e.g., are positioned outside 596 of the inflatable surfing apparatus).

[0067] Although the embodiments shown and described above feature water attractions having particular configurations or shapes, an inflatable material or inflatable components may be implemented on any of a variety of water or other attractions. In one example, entry and/or exit locations for a rider to enter and/or exit from a water ride may differ from those explicitly shown in the embodiments illustrated (e.g., a staircase may be located at an alternative position or no staircase may be used). In another example, a water attraction, such as a standing wave surfing ride, may have its entire main structure or riding surface as an inflatable structure or made from an inflatable material. Alternatively, a water attraction, such as a standing wave surfing ride, may only be constructed only partially with inflatable structures and other components of the ride being non-inflatable, for example, to aid in stability or to increase the load-bearing characteristics of the ride. Although the various embodiments illustrated and described incorporate a variety of features, components, and/or operation, not all such features, components, and/or operation may be utilized within a desired embodiment. Instead, certain, but not all, of the features, components, and/or operation may be chosen for a particular embodiment.

[0068] The inflatable portion may be positioned at any desired location along the water attraction, for example, to provide a less rigid surface for more comfortably supporting riding thereon and/or to absorb an impact of the rider or a ride vehicle. For example, the inflatable structure may be completely above ground, completely below ground, or partially above and below ground. In some embodiments, a water reservoir of the water attraction may be made of the inflatable material. A water attraction using an inflatable portion or portions may be modular in nature such that it may be more easily manufactured, transportable, and/or constructed on a given location. For example, a water attraction using an inflatable portion or portions may be designed to be portable such that it is intended to be used at a given geographic location for a short period and then deflated and/or deconstructed and shipped to a new location.

[0069] Turning to FIG. 6A, an inflatable surfing apparatus 600 is shown from an exploded perspective view. The surfing apparatus 600 includes an inflatable base 602 that defines at least some of the boundaries for a support structure for supporting various components or surfaces of the surfing apparatus 600. The inflatable base 602 may comprise a plurality of inflatable segments connected together (for example via drop-stitching 604 and vertical support 606). The inflatable base 602 may be anchored to a supporting structure (for instance, a supporting structure comprising steel beams). In one embodiment, one or more bumpers 700 (see FIG. 7) may be placed between the inflatable base 602 and the supporting structure. The bumper 700 comprises a shock-absorbing body 712 which may be secured to the inflatable base 602 and/or the support structure via attaching elements 710, 711.

[0070] An inflatable riding surface 630 is positioned on top of the inflatable base 602 and defines a surface for riders to slide or surf upon, with or without a ride vehicle. The rigidity of the inflatable riding surface 630 may be adjusted by adjusting the inflation level of the inflatable

riding surface **630**. The inflatable riding surface **630** may also include one or more connectors **625** for connecting one or more vertical walls (which may be inflatable, non-inflatable, or may include cushioned material) as further described in connection with FIGS. 8A and 8B hereunder. In one embodiment, the inflatable riding surface **630** is formed by connecting (via drop-stitching for example) a plurality of inflatable surface strips **620**, **622** in order to form a particular shape of riding surface (for example, a half-circular shape). In one embodiment, the plurality of inflatable surface strips are also connected via a pocket **610** within which a rigid element **611** (for instance a rigid pipe) is disposed, which may be used to maintain the shape of the riding surface **630** as water is jetted against it. In another embodiment, a protective sheet **640** is placed on the inflatable riding surface **630**.

[0071] FIG. 6B illustrates an exploded rear-perspective view of the inflatable surfing apparatus **600** depicted in FIG. 6A. As shown, the protective sheet **640** is placed on top of the inflatable riding surface **630**. In one embodiment, the inflatable base **602** includes a plurality of vertical support **606** and an additional supporting structure **603**.

[0072] In one embodiment, the inflatable surfing apparatus may include one or more vertical walls that may be inflatable, non-inflatable, or may include cushioned material. As shown in FIG. 8A, a vertical wall **801** is installed on the riding surface **802** or on the inflatable base. A platform **803** for exiting or entering the inflatable surfing apparatus may be attached to the vertical wall **801**. FIG. 8B illustrates a half-circular riding surface **804** that includes vertical walls **801** and platforms **803** installed at the ends of the half-circular riding surface **804**.

[0073] FIG. 9 is a perspective view of the platform **900** described herein according to an embodiment of the present invention. The platform comprises a first portion **901**, a second portion **902**, and attachment elements (for example, string ties) **903**. The second portion may be

positioned under a vertical wall, and the attachment elements may be used to ensure the platform **900** is securely fastened to a vertical wall.

[0074] Any of a variety of embodiments of a surfing apparatus may be made using some or all of the features previously disclosed herein. As previously discussed, a supporting material, pad, or structure (e.g., an inflatable kicker, such as a drop-stitch material or other material capable of sealing air, a rigid material, etc.) may be provided beneath a riding surface (e.g., a protective sheet, or other inflatable, such as drop-stitch material, or non-inflatable material). During construction, a temporary sheet may be placed between the supporting material, pad, or structure and the riding surface, such temporary sheet removed after construction so that the supporting material, pad, or structure and the riding surface are directly adjacent. Water flowing over the riding surface is permitted to drain at a rear of the surfing apparatus into a reservoir for recirculation. As discussed, for example in FIG. 5B, drainage may be permitted via a grating (e.g., extended rods) positioned at the rear of the surfing apparatus. The grating may be formed of rods having a variety of different diameters or lengths. In certain embodiments a padded mat may be disposed atop the grating. In alternative embodiments, no padded mat may be used and/or the grating itself may be padded.

[0075] In certain embodiments, it may be desirable to drain water as quickly and/or in as short a distance as possible in order to aid in slowing a rider down once the rider has traveled into the drainage area of a surfing apparatus and/or shorten the recovery footprint and, therefore, associate ride space required to recover outflows of water. The grating or rods may have a textured or contoured surface that increases their coefficient of friction and/or effect the flow characteristics of the passing water in order to help drain water quicker. In an exemplary embodiment, the grating or rods include a surface configured to increase water turbidity and

create a non-laminar flow. In an exemplary embodiment, the grating or rods include a surface configured to aid in stopping a rider's movement (e.g., due to increased friction acting upon a rider or the rider's board) should a rider be sliding on top of the grating or rods. In an exemplary embodiment, the grating or rods may have a thin diameter and/or be spaced apart from one another to support additional drainage of water therebetween. In an exemplary embodiment, the grating or rods may have an increased textured surface and reduced diameter size as compared to conventional structures. In an exemplary embodiment, the recovery area may be reduced or shortened and/or the grating space between adjacent rods or grates may be reduced as compared to conventional systems. In an exemplary embodiment, the grating or rod includes a helical or spiral protrusion extending around and along a length of the grate and/or rod of a recovery area. The protrusion may be positioned under a sealant and/or covering, such that the protrusion's outer surface in contact with the water flow is either a continuous/gradual contour of the outer surface of the grating/rod, or discontinuous/step-wise extension from the outer surface of the grating/rod. The outer surface of the protrusion and/or grating/rod surface may be textured, such as roughened, patterned, printed, indented, protuberant, or otherwise provide a non-smooth, non-uniform surface contact. In certain embodiments, flaps (e.g., vinyl) or other components may be positioned adjacent to the drainage area to help direct water that does not drain through the drainage area into the reservoir of the surfing apparatus.

[0076] The supporting material, pad, or structure may be positioned and/or fastened with other components of the surfing apparatus, such as the substructure, base or other support beams (e.g., stainless steel beams that extend across a top of a water reservoir) of the surfing apparatus. The riding surface may be fastened, such as with Velcro, to the supporting material, pad or structure. In this way, as previously discussed, the supporting material, pad, or structure can

provide overall shape (e.g., provide an inclined slope) for riders that are riding upon a flow of water that is provided from water delivery components, such as nozzles, of the surfing apparatus onto the riding surface.

[0077] For example, as illustrated in the embodiment shown in FIG. 10, a surfing apparatus **1000** may include one or more nozzles **1005** for outputting a flow **1010** of water and having a substructure or base **1020** comprised of beams, walls, columns, etc. The surfing apparatus **1000** may include features that are the same as or similar to those previously discussed. The substructure or base **1020** may be inflatable or may be non-inflatable (e.g., made of steel). A supporting material, pad, or structure **1030** may be disposed beneath a ride surface **1040** (e.g., may be fastened or connected together). The supporting material, pad, or structure **1030** may be an inflatable material (e.g., drop-stitch or other sealed-air material) in certain embodiments. The ride surface **1040** may be an inflatable material (e.g., drop-stitch) in certain embodiments. As previously discussed, the one or more nozzles **1005** of the surfing apparatus **1000** may be desirably located within a certain proximity, height, or other adjacent distance to the ride surface **1040**.

[0078] In the example shown in FIG. 10, the proximity of the ride surface **1040** to the one or more nozzles **1005** may be adjusted via a riser **1050** that is positioned between the supporting material, pad, or structure **1030** and the substructure or base **1020**. The riser **1050** may be made of an inflatable material. Thus, in one embodiment, the riser **1050** may be inflated with greater amounts of air or other gas or fluid to reduce the proximity of the ride surface **1040** to the one or more nozzles **1005** and/or deflate the riser **1050** to increase the proximity of the ride surface **1040** to the one or more nozzles **1005**. This adjustment of the proximity or distance of the ride surface **1040** to the one or more nozzles **1005** via the riser **1050** may be performed

during the initial setup or construction of the surfing apparatus **1000** and/or, in certain embodiments, performed after the initial setup or construction of the surfing apparatus. In an alternative embodiment, the riser **1050** may not be inflatable or adjustable. In another embodiment, additional risers may be used in alternative locations of the surfing apparatus **1000**. In still another embodiment, no riser **1050** may be used for the positioning or proximity of the ride surface **1040** or other components of the surfing apparatus **1000** with one another.

[0079] FIG. 11 illustrates another embodiment for a surfing apparatus **1100**. The surfing apparatus **1100** may include features that are the same as or similar to those previously discussed. For example, as previously discussed at least for the embodiment of FIG. 6A, it may be desirable to help maintain shape of a ride surface even when subjected to the force of water jetting against it via one or more rigid elements and/or pockets. The surfing apparatus **1100** includes one or more nozzles **1105** that provide a flow of water **1110** onto a ride surface **1140**. The velocity of the flow of water **1100** may, in some embodiments, operate to change the shape of the ride surface **1140**, for example, by causing the ride surface **1140** or portions or segments of the ride surface **1140** to change their position with respect to the one or more nozzles **1105** (e.g., the flow of water **1100** may operate to “push” the ride surface **1140** away from the one or more nozzles **1105**). As previously discussed, a supporting material, pad, or structure **1130** may rest upon a substructure or base of the surfing attraction **1100**, but may not be fastened to the substructure or base and therefore may not be sufficient in keeping the ride surface **1140** from moving due to the flow of water **1100**.

[0080] A rigid element **1120** (e.g., a pipe) that is connected **1122** with a stable portion of the surfing apparatus **1100** (e.g., the substructure or base of the surfing apparatus **1100**, the one or more nozzles **1105** of the surfing apparatus **1100**, etc.) may interact with a portion **1150** of the

ride surface **1140** that forms a pocket **1155**. Accordingly, the rigid element **1120** may be adjustably located in order to position and/or maintain the ride surface **1140** at a desired location (e.g., with respect to the one or more nozzles **1105**) despite the flow of water **1110** being disposed onto the ride surface **1140**. In one embodiment, the portion **1150** may be a vinyl material as illustrated that is connected with the ride surface **1140** and forms the pocket **1155**. In another embodiment, the portion **1150** or pocket **1155** may be integral with the ride surface **1140** such that the rigid element **1120** is directly disposed into the ride surface **1140**. In an alternative embodiment, any of a variety of possible connections may be made (e.g., adhesives, bolts, screws, etc.) other than through the use of elements with a pocket for positioning and/or maintaining the ride surface **1140** at a desired location. The rigid element **1120** may be adjustably tensioned with the ride surface **1140** (e.g., by adjusting a position of the rigid element **1120** once connected with the ride surface via the portion **1150** or pocket **1155**).

[0081] FIG. 12 illustrates another embodiment for a surfing apparatus **1200**. The surfing apparatus **1200** may include features that are the same as or similar to those previously discussed. For example, as previously discussed at least for the embodiment of FIG. 6A, a complete ride surface may be made of multiple ride surface sections or strips. A first ride surface section **1210** may be positioned adjacent to a second ride surface section **1220**. The first and/or second ride surface sections (**1210**, **1220**) may be made of an inflatable material, such as drop-stitch. Due to the nature of inflatable materials, the corners of the first and/or second ride surface sections (**1210**, **1220**) may not form a perfect 90-degree angle. Accordingly, when placed adjacent to one another, a gap **1250** may be present.

[0082] The gap **1250** may undesirably cause water flow disturbances or turbulence, or otherwise impact the unimpeded riding upon the ride surface formed by at least the first and/or

second ride surface sections (1210, 1220). As previously discussed, a sheet or other material 1230 may be positioned and/or fastened with the ride surface. Because the gap 1250 may still impact water or rideability of the surfing apparatus 1200, even with the presence of the sheet or other material 1230, a filling element 1240 may be fully or partially disposed into a pocket, cavity, or other portion of the sheet or other material 1230. In an alternative embodiment, the filling element 1240 may not be disposed within the sheet or other material 1230, but instead may be fully or partially disposed within a pocket, cavity, or other portion of the first ride surface section 1210 and/or the second ride surface section 1220. In still another embodiment, the filling element 1240 may merely be fastened or connected (e.g., using an adhesive) to an outside surface of the sheet or other material 1230, the first ride surface section 1210 and/or the second ride surface section 1220. The filling element 1240 may be a soft material, such as foam or other padding, or, in an alternative embodiment, be a more rigid material, such as fiberglass, plastic, metal, or other such composite.

[0083] Filling elements may be used in other areas of the surfing apparatus 1200, for example in connecting surfaces (e.g., inflatable surfaces) that are not both ride surface sections. For example, as previously discussed, slides or other amusement features (e.g., inflatable features) may be connected as part of a surfing apparatus, for example, to provide an exit for a rider to slide or travel along when exiting from the surfing apparatus (e.g., an inflatable slide or stairs leading from a drain portion of a surfing attraction). Accordingly, one or more filling elements may be positioned at connection locations between such inflatable surfaces. Non-inflatable surfaces of a surfing apparatus that similarly form gaps when placed adjacent one another may also utilize filling elements therebetween in certain embodiments as desired.

[0084] The previous description of the disclosed examples is provided to enable any person of ordinary skill in the art to make or use the disclosed methods and apparatus. Accordingly, the terminology employed throughout should be read in a non-limiting manner. Various modifications to these examples will be readily apparent to those skilled in the art, and the principles defined herein may be applied to other examples without departing from the spirit or scope of the disclosed method and apparatus. The described embodiments are to be considered in all respects only as illustrative and not restrictive and the scope of the invention is, therefore, indicated by the appended claims rather than by the foregoing description. All changes which come within the meaning and range of equivalency of the claims are to be embraced within their scope. Skilled artisans may implement the described functionality in varying ways for each particular application, but such implementation decisions should not be interpreted as causing a departure from the scope of the disclosed apparatus and methods. The steps of the method or algorithm may also be performed in an alternate order from those provided in the examples.

CLAIMS

1. A water ride, comprising:

a riding surface;

an inflatable first layer positioned under the riding surface;

an inflatable second layer positioned under the riding surface;

a nozzle for dispensing water onto the riding surface; and

a drainage area for recovering the water from the riding surface.

2. The water ride of claim 1, wherein the first layer is positioned under the second layer such that the first and second layers support and stabilize the riding surface.

3. The water ride of claim 1, wherein the inflatable first layer and inflatable second layer are separately inflatable, and the riding surface is separate from the inflatable first layer and the inflatable second layer.

4. The water ride of claim 3, wherein the riding surface is not inflatable and comprises a tensioned material.

5. The water ride of claim 1, wherein the first layer has separate inflatable compartments such that desired portions of the first layer are inflated to influence a waveform generated on the ride surface.

6. The water ride of claim 1, wherein the inflatable first layer defines a thin layer relative to the inflatable second layer, and the inflatable second layer defines a varying thickness such that the inflatable second layer creates a sloped surface to provide an inclined shape for the riding surface.

7. The water ride of claim 6, further comprising a support structure under the first and second layers and riding surface.
8. The water ride of claim 7, wherein the support structure defines a water reservoir under the first and second layers and riding surface.
9. The water ride of claim 8, further comprising a connector configured to maintain a desired relative position between the ride surface and the nozzle.
10. The water ride of claim 9, wherein the connector comprises a packet on the inflatable first layer and the surfing attraction further comprising an element configured to position within the pocket.
11. The water ride of claim 10, wherein the element is rigid and vertically adjustable.
12. The water ride of claim 8, wherein the inflatable first layer comprises a plurality of inflatable strips positioned adjacent each other to define a particular shape.
13. The water ride of claim 12, wherein the particular shape is a partial circle.
14. The water ride of claim 8, wherein the drainage area comprises a surface configuration for increasing water turbidity to create non-laminar flow.
15. The water ride of claim 14, wherein the drainage area comprises a plurality of rods defining gaps between adjacent rods, and an exterior surface of the rods comprises a spiral protrusion around and along a length of the rod.
16. The water ride of claim 15, wherein an outer surface of the plurality of rods includes a textured surface.

17. A surfing attraction, comprising,

a nozzle for emitting a flow of water;

an inflatable ride surface adjacent to the nozzle, the ride surface configured to receive the flow of water from the nozzle;

an inflatable riser positioned beneath the supporting material and configured to be adjustably inflated for positioning an elevation of the ride surface with respect to the nozzle; and

a connector configured to retain the inflatable ride surface relative to the nozzle when the inflatable ride surface is receiving the flow of water from the nozzle.

18. The surfing attraction of claim 17, wherein the connector comprises a pocket on the inflatable ride surface and a rigid element configured to be positioned within the pocket of the ride surface.

19. The surfing attraction of claim 18, wherein a position of the rigid element is adjustable for maintaining a location of the ride surface with respect to the nozzle.

20. The surfing attraction of claim 19, wherein the inflatable ride surface is not directly attached to the inflatable riser.

21. The surfing attraction of claim 20, wherein the inflatable ride surface comprises a plurality of inflatable sections positioned next to each other across the inflatable riser.

22. The surfing attraction of claim 20, wherein a gap is created between adjacent sections of the plurality of inflatable sections, and the surfing attraction comprises a filling element in each of the gaps between adjacent sections of the plurality of inflatable sections.

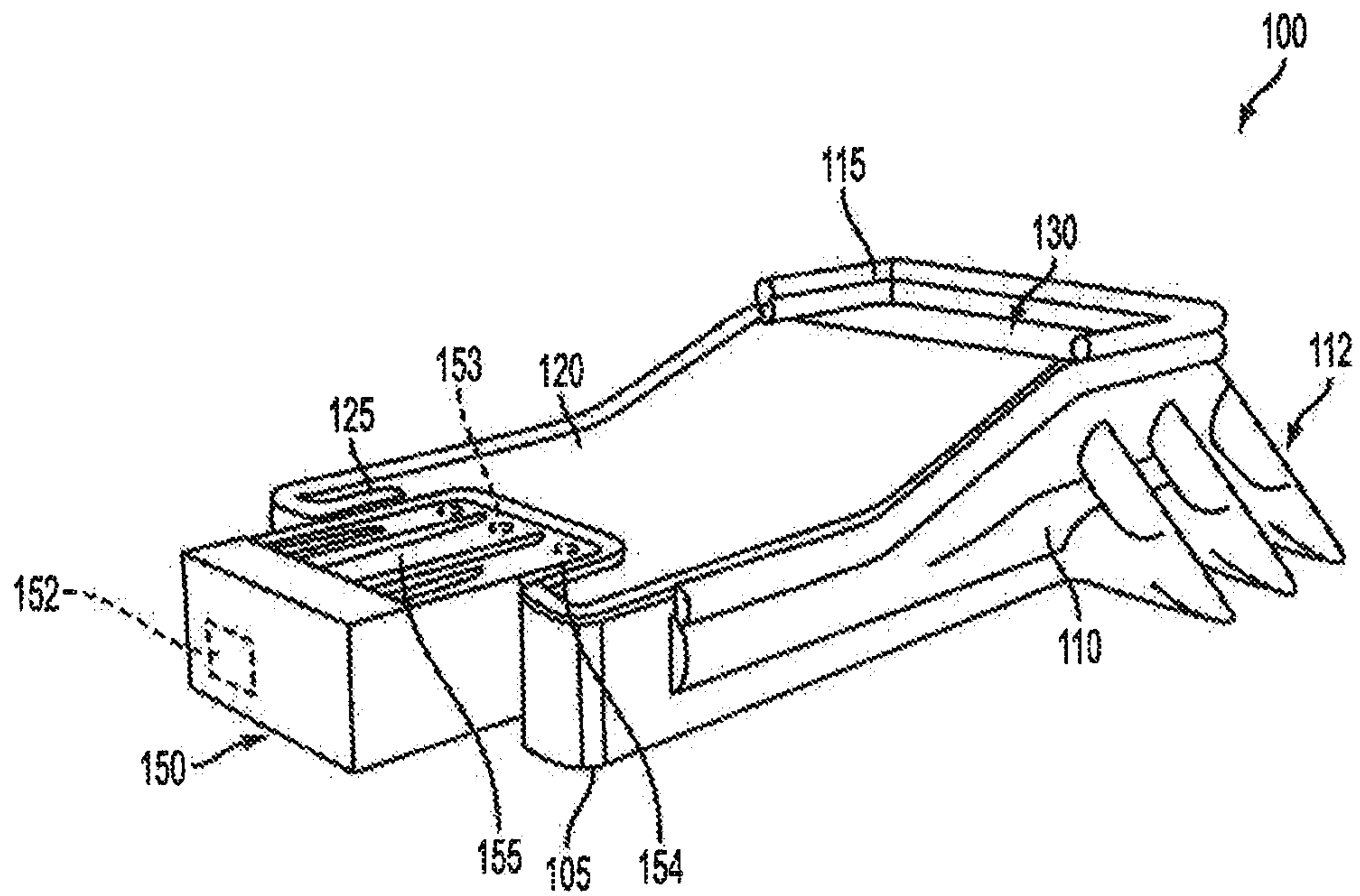

FIG. 1

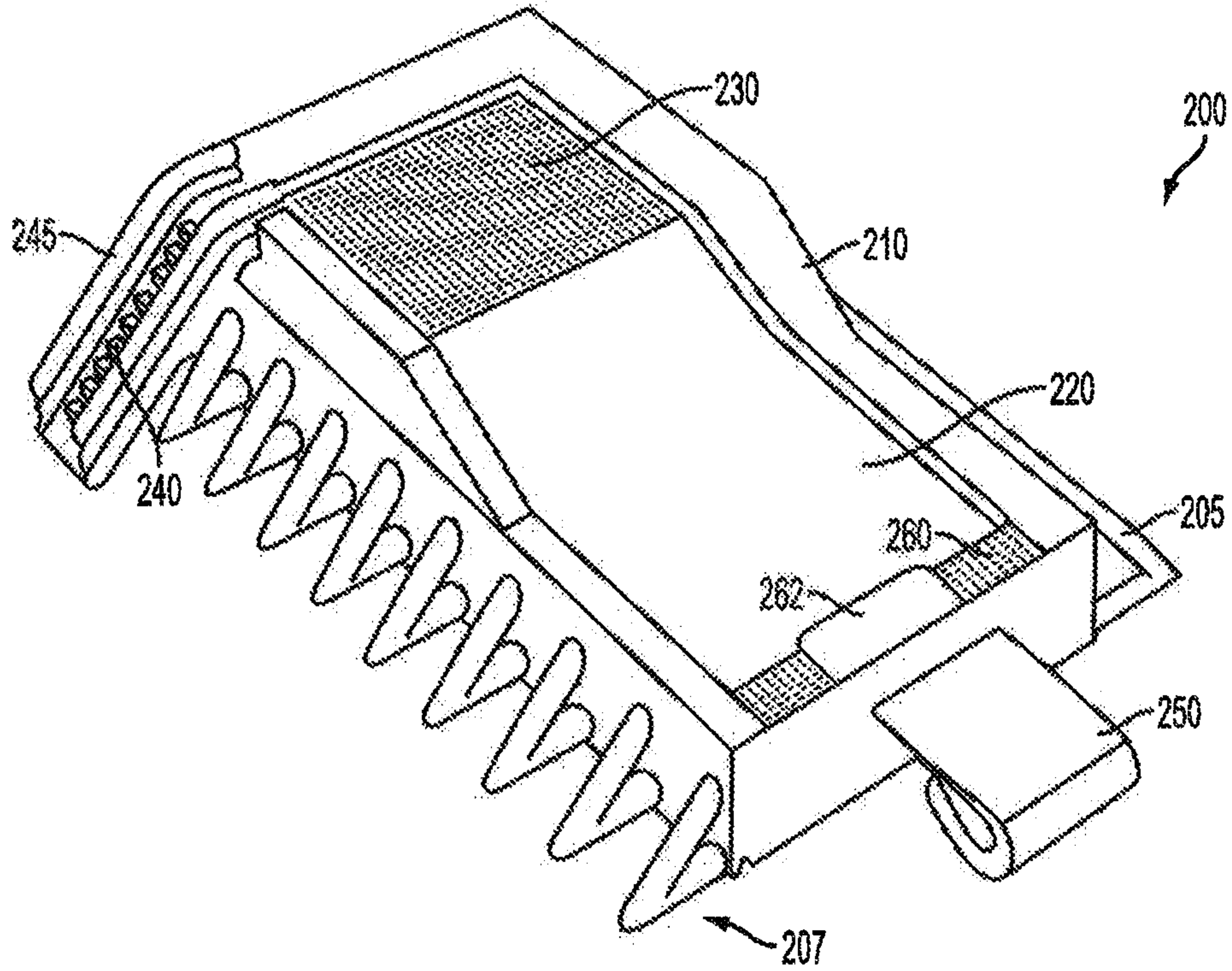

FIG. 2A

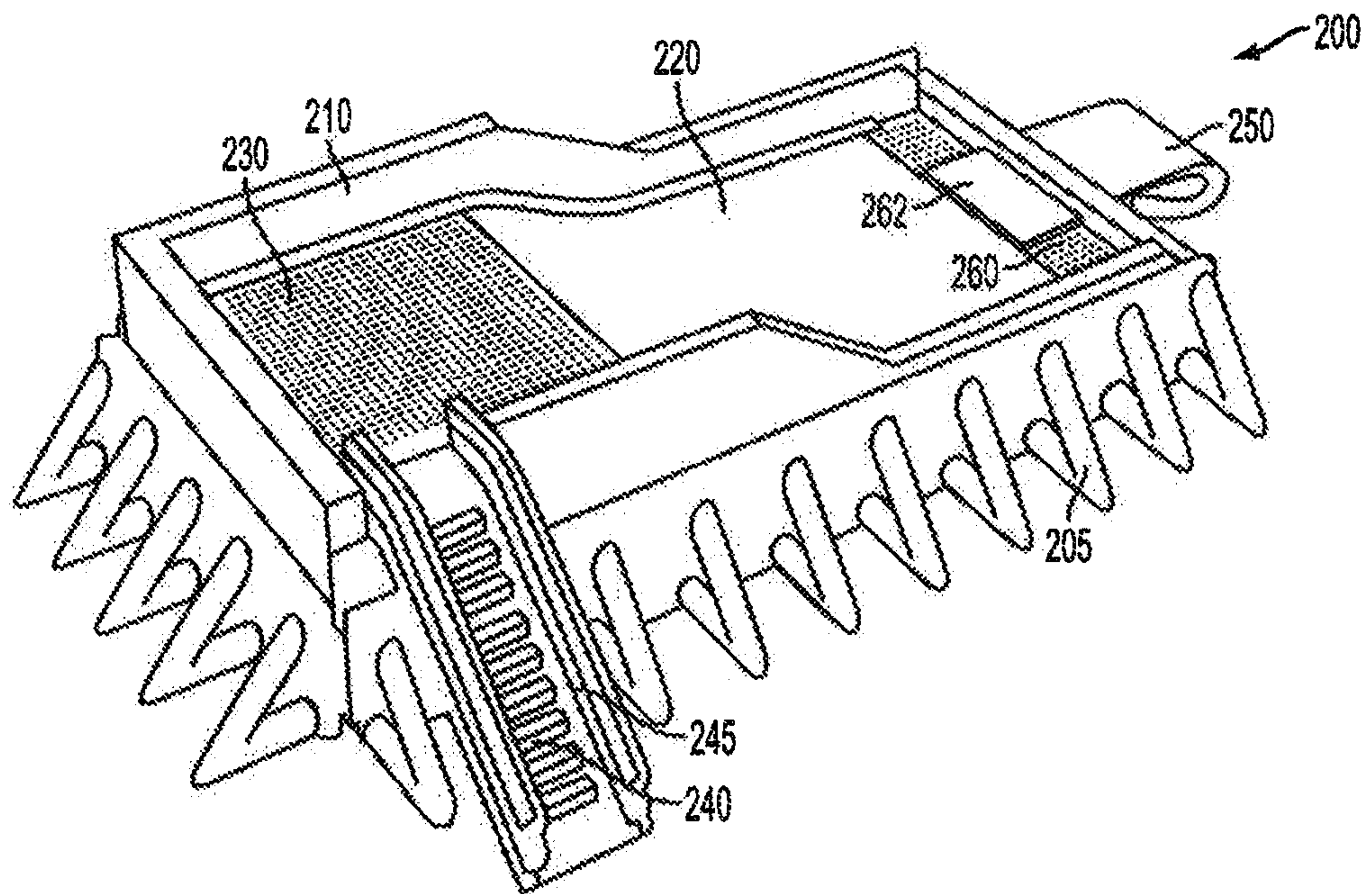

FIG. 2B

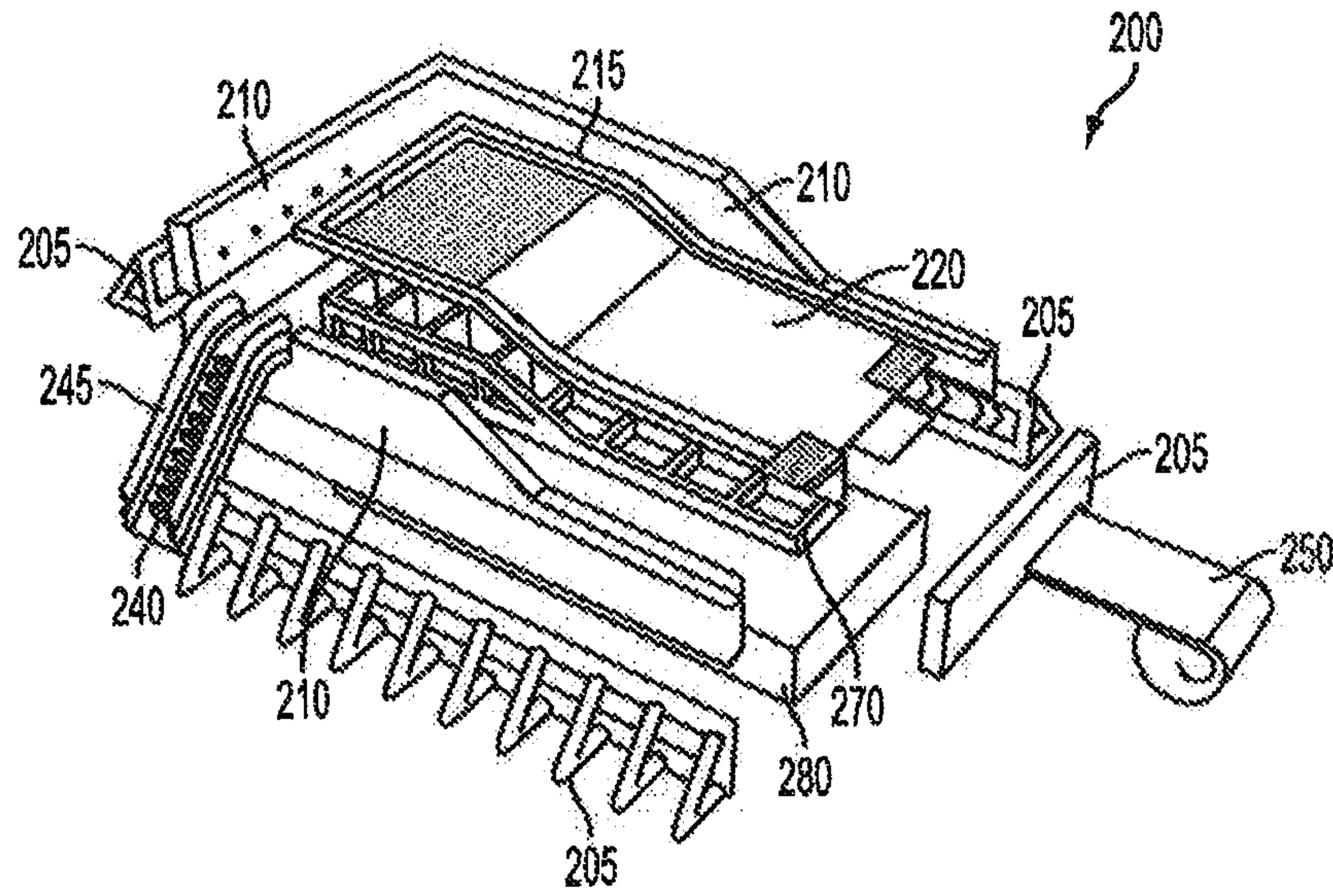

FIG. 2C

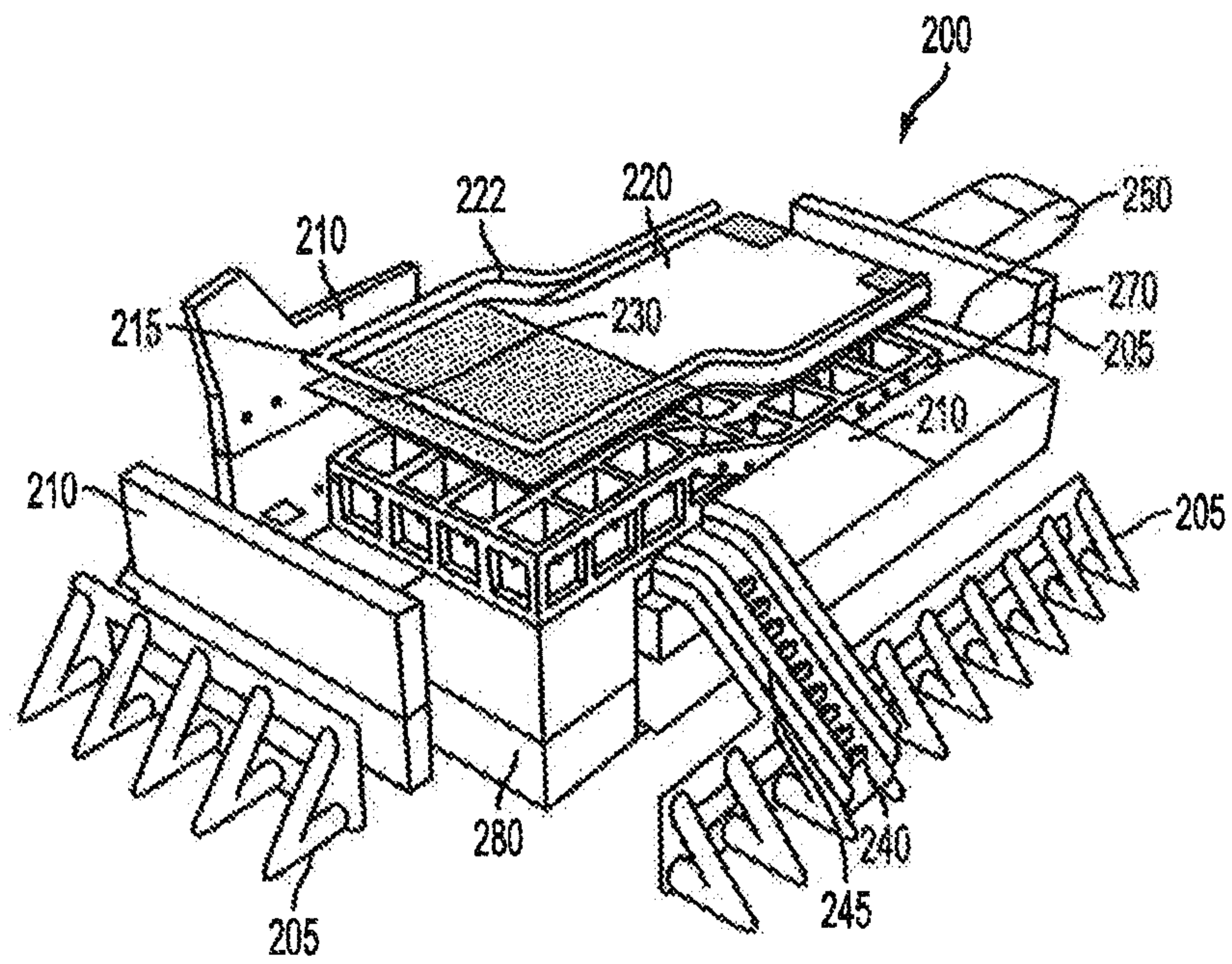

FIG. 2D

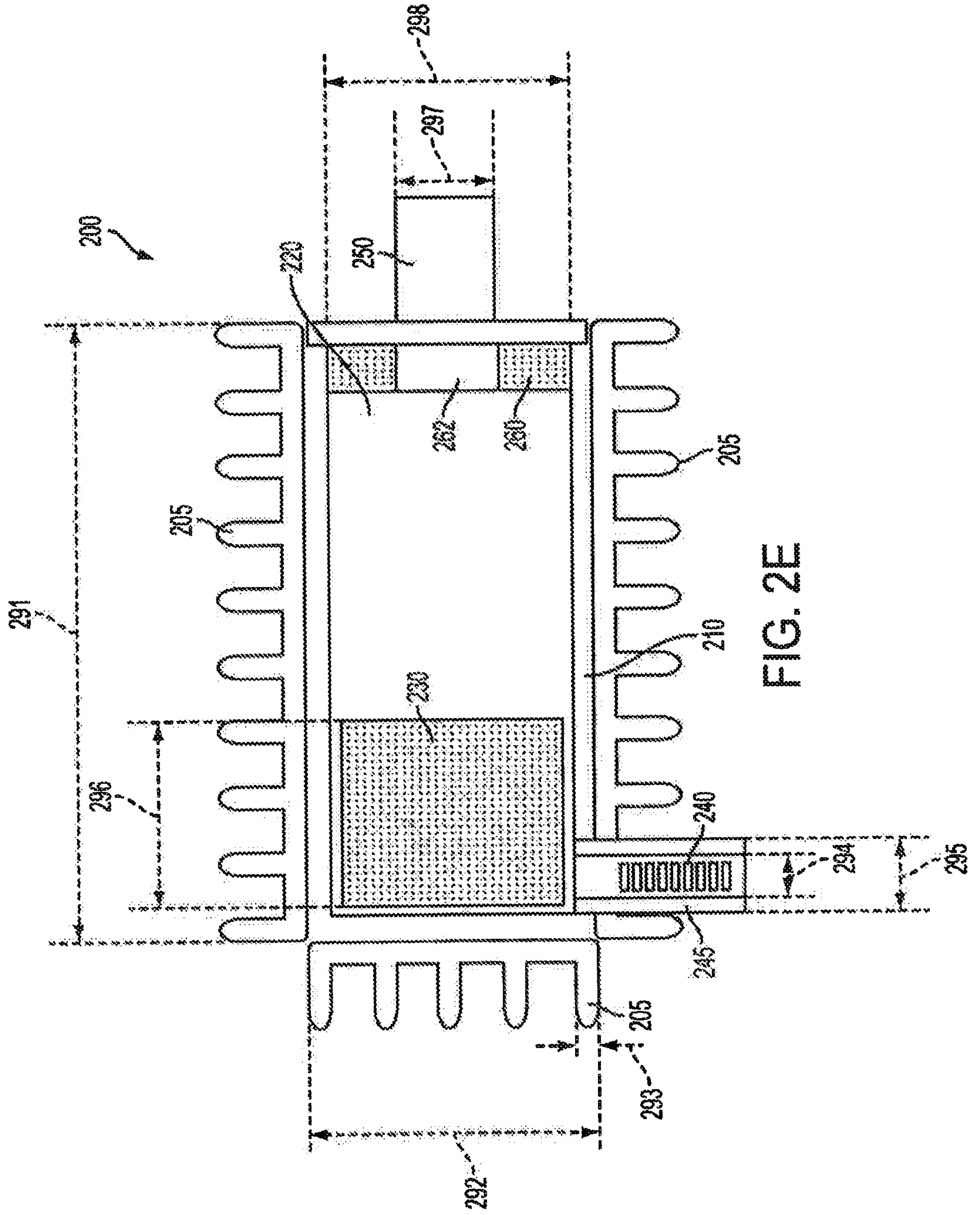

FIG. 2E

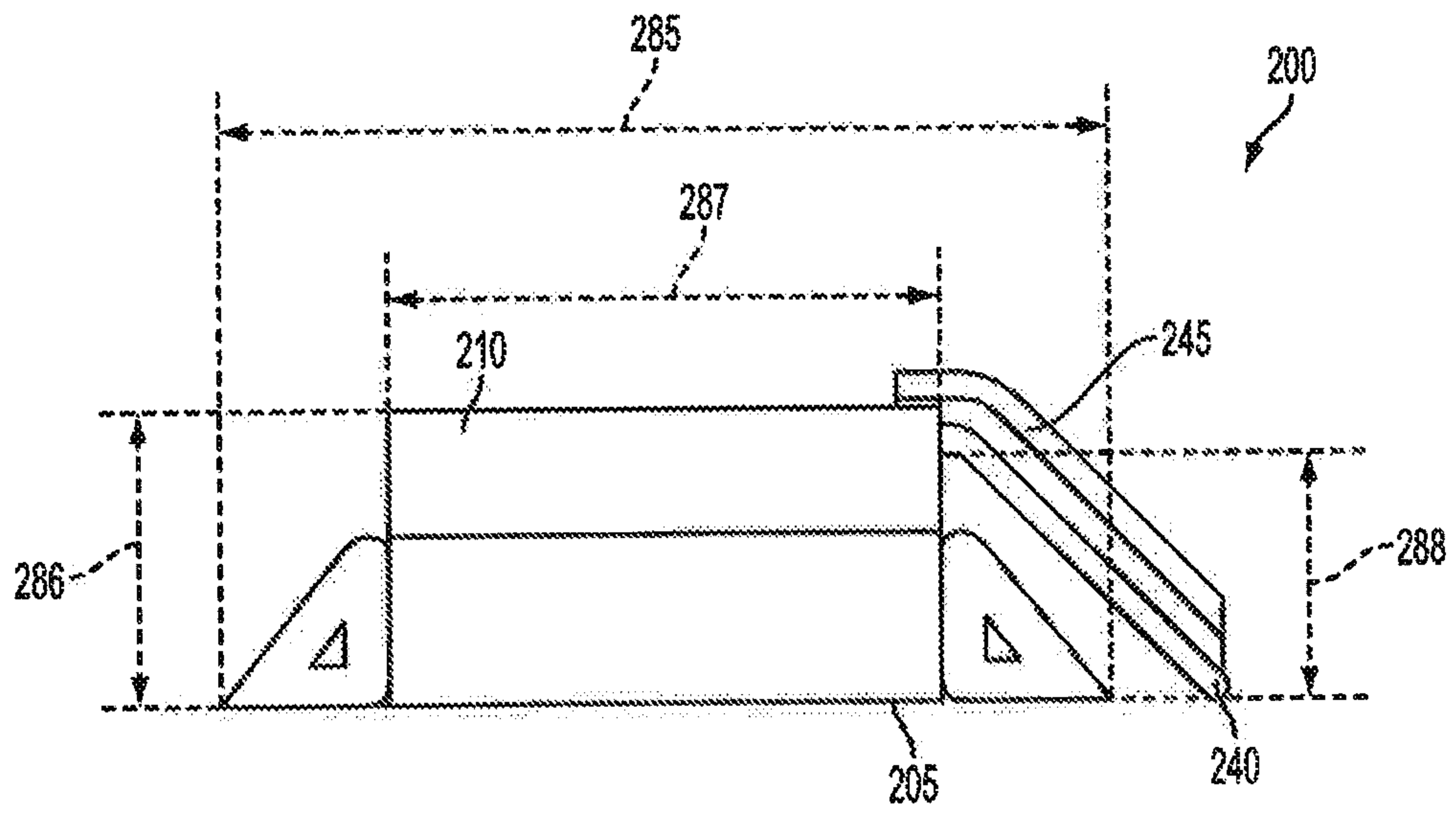

FIG. 2F

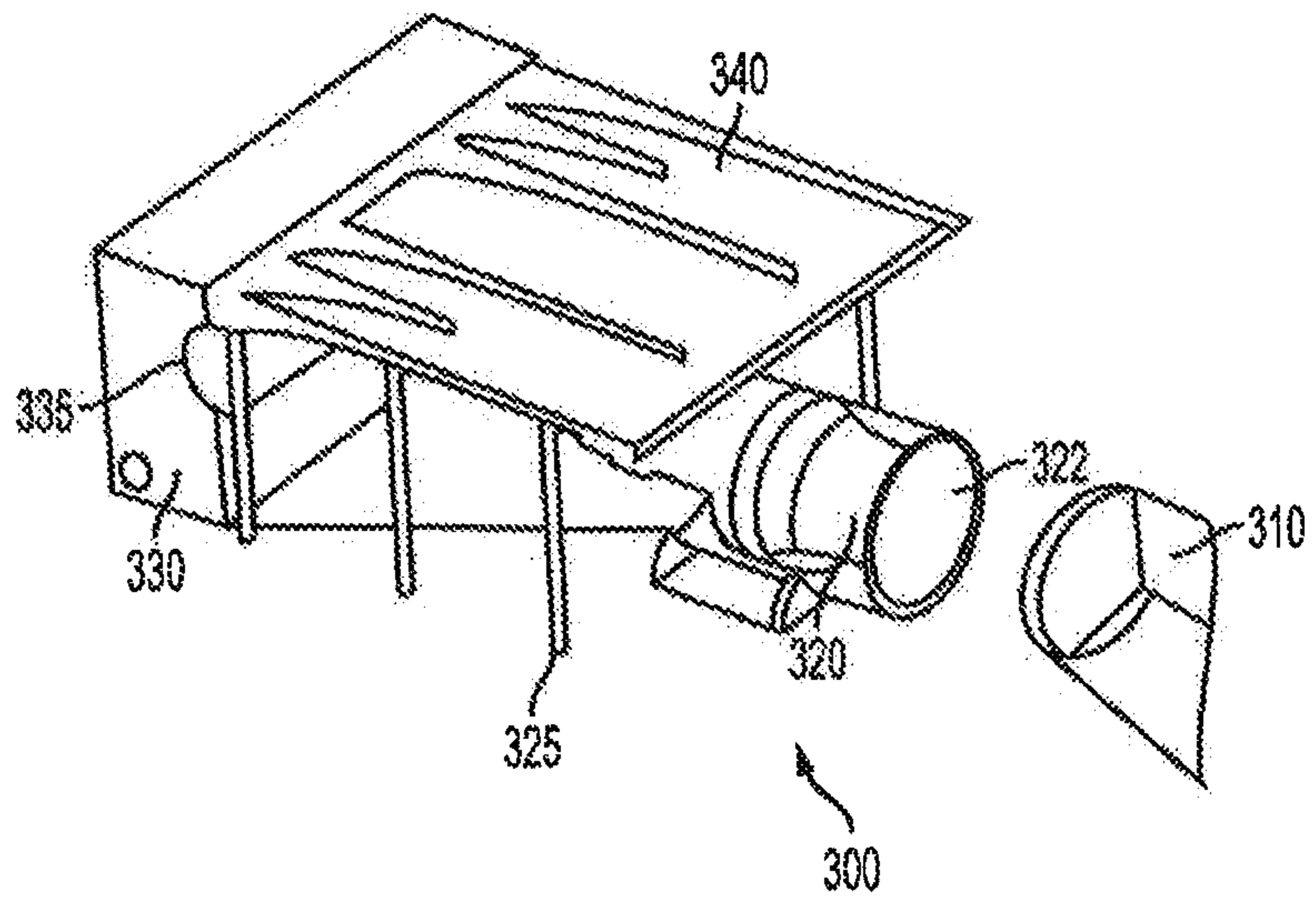

FIG. 3A

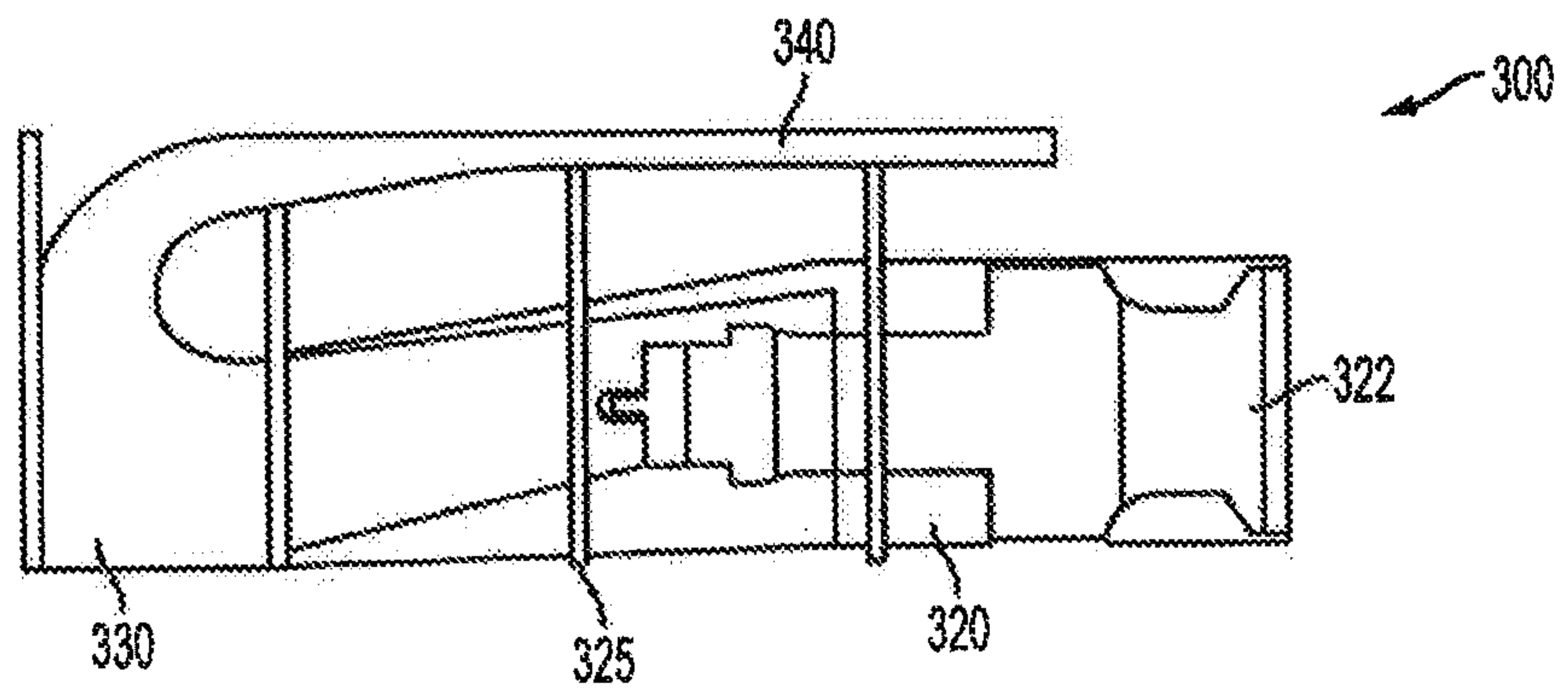

FIG. 3B

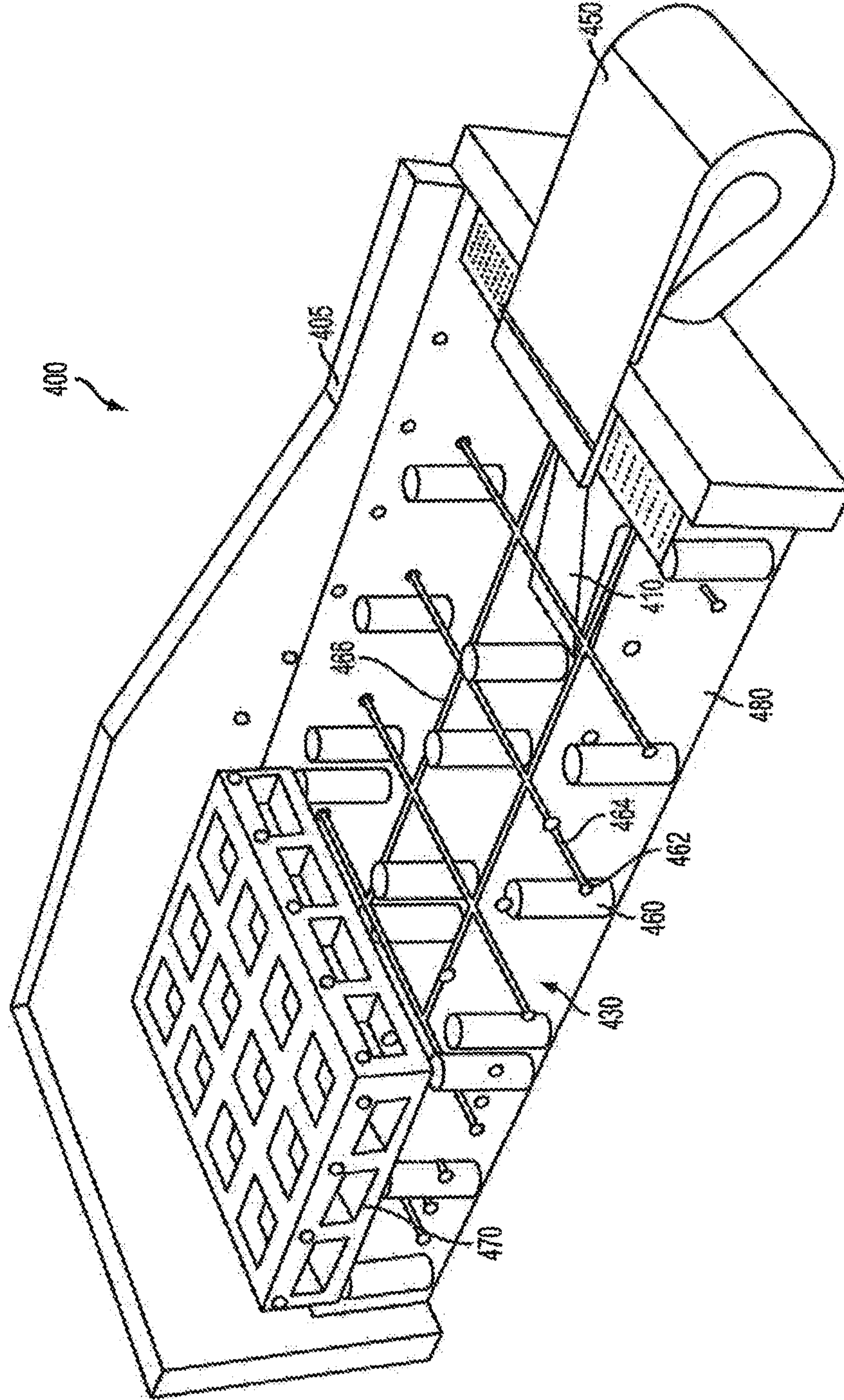

FIG. 4A

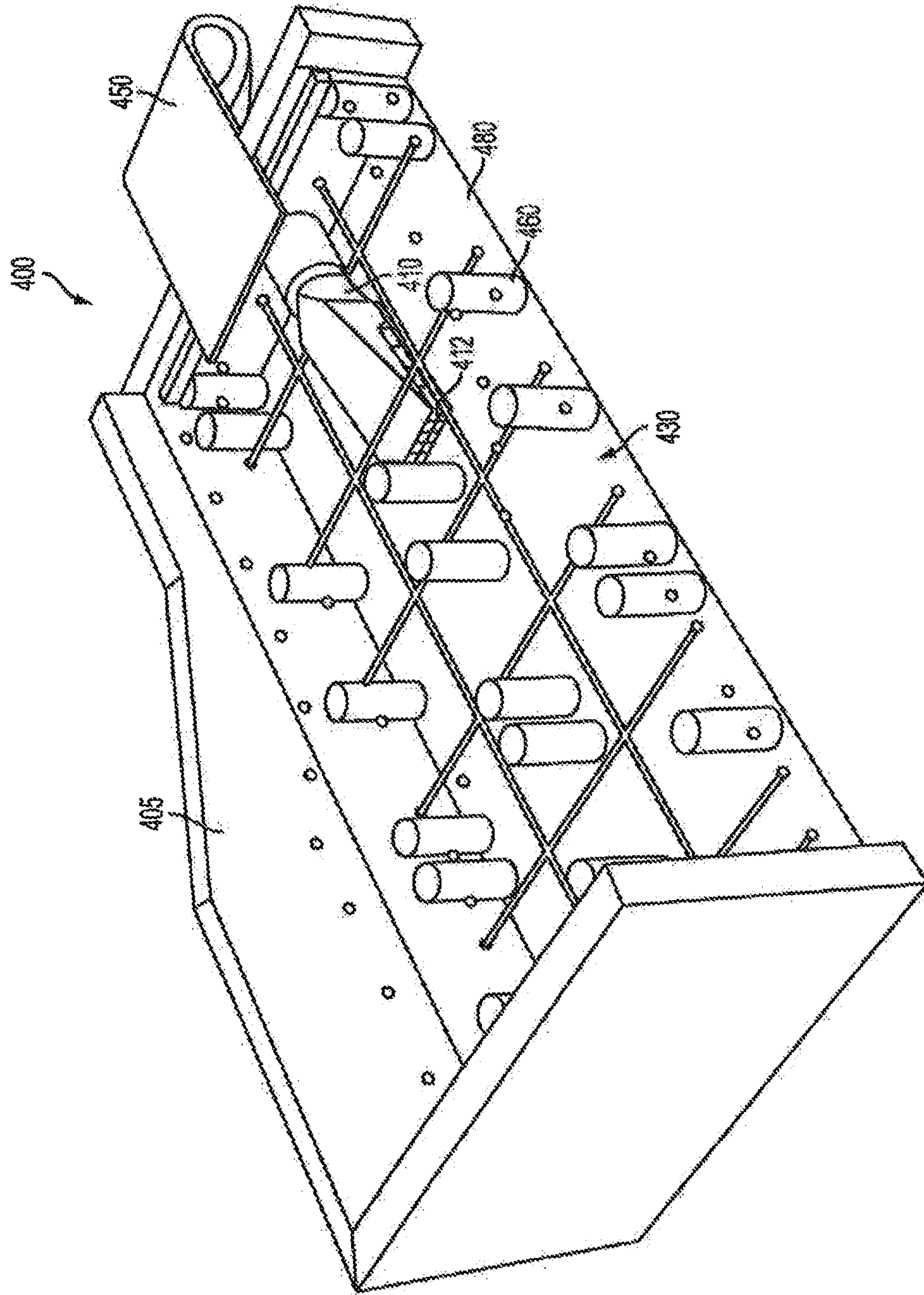

FIG. 4B

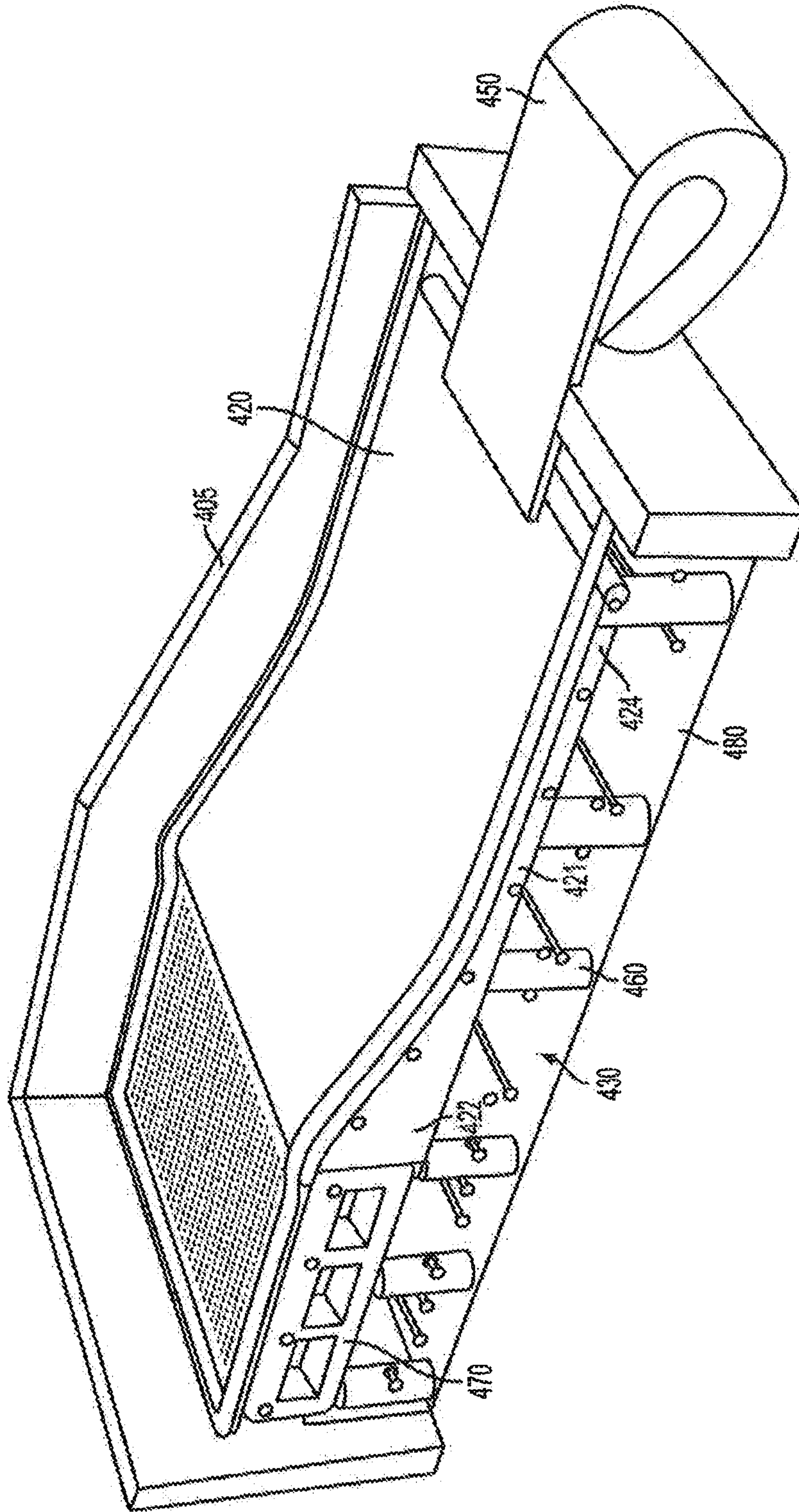

FIG. 4C

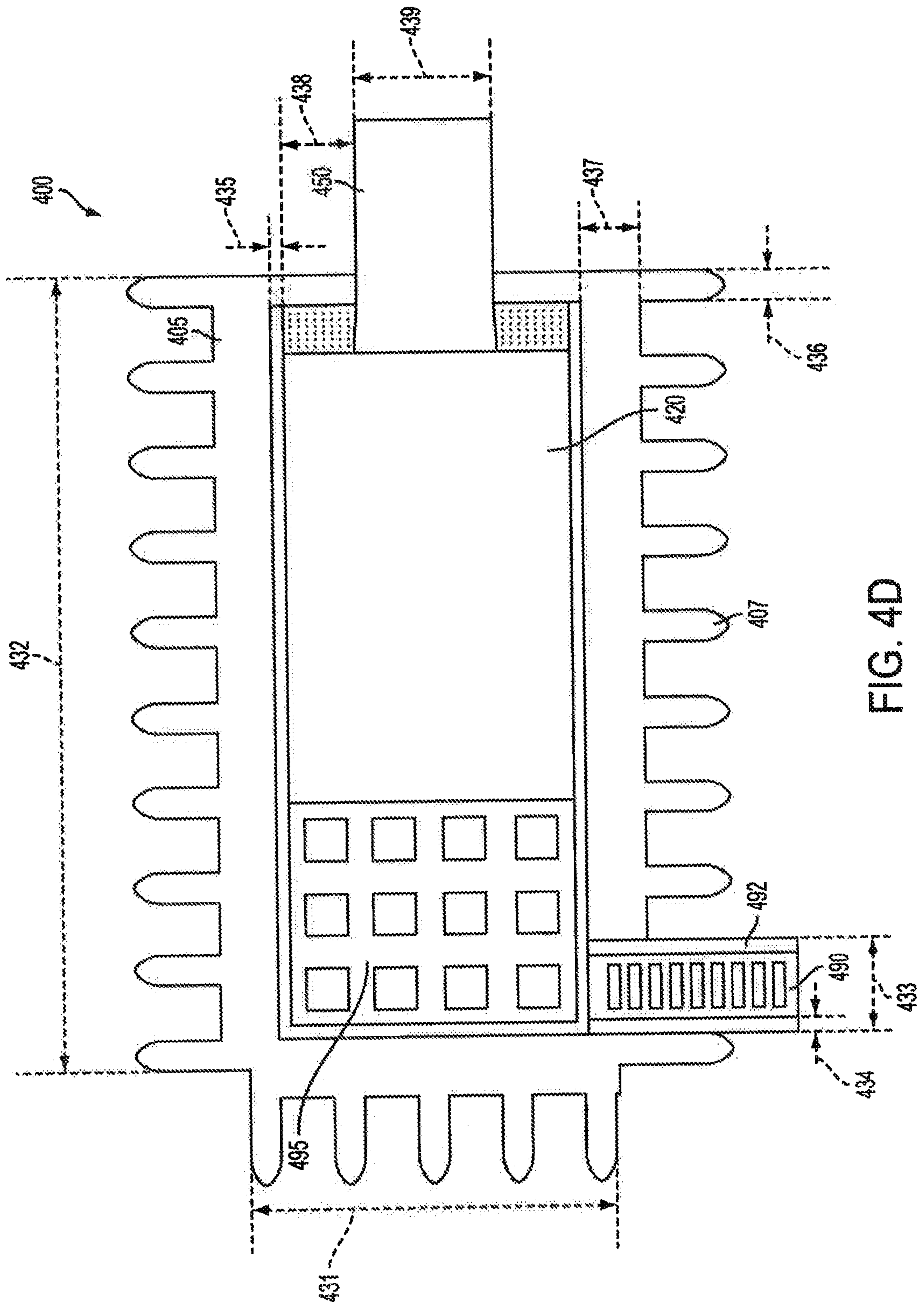

FIG. 4D

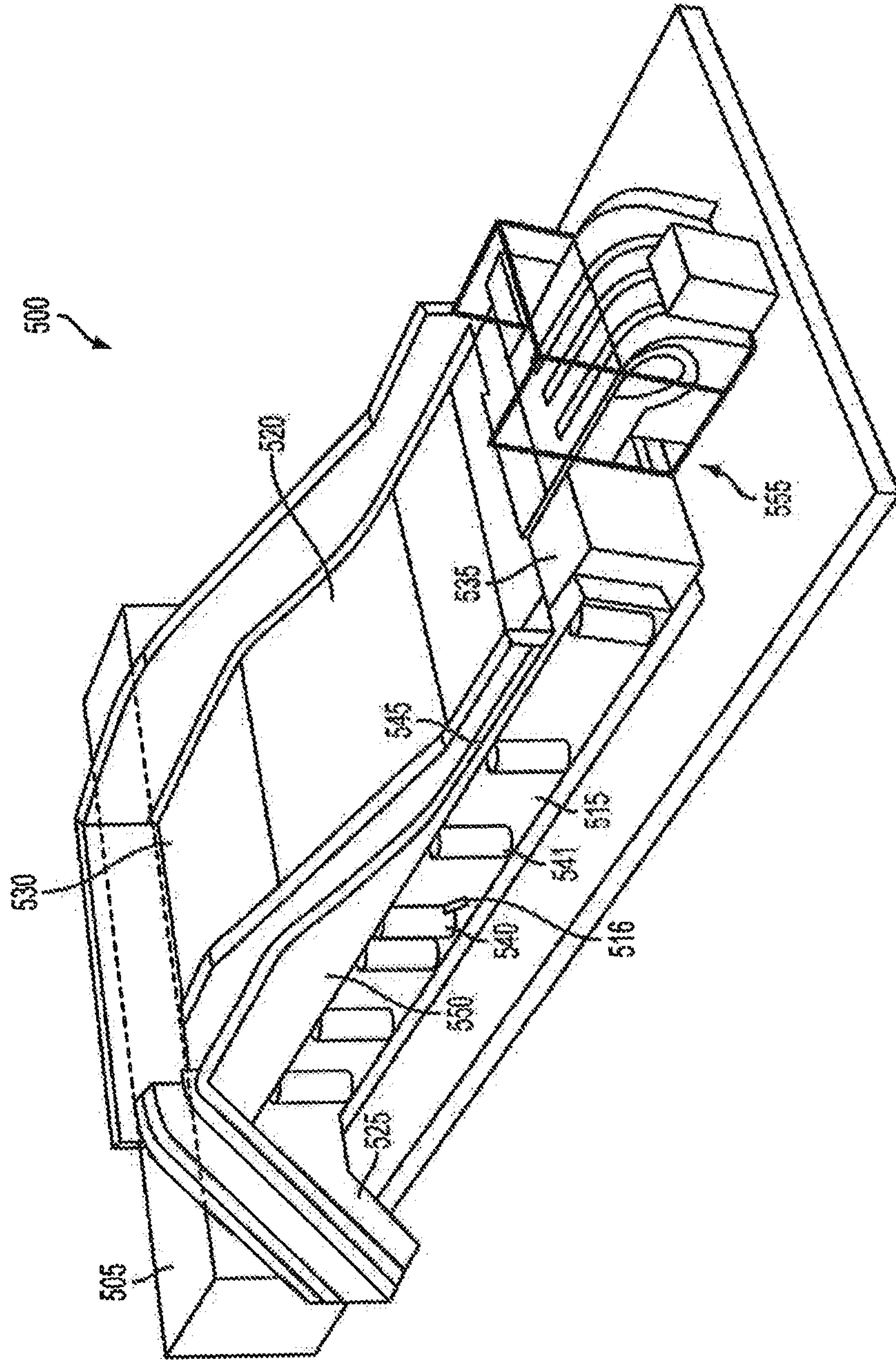

FIG. 5A

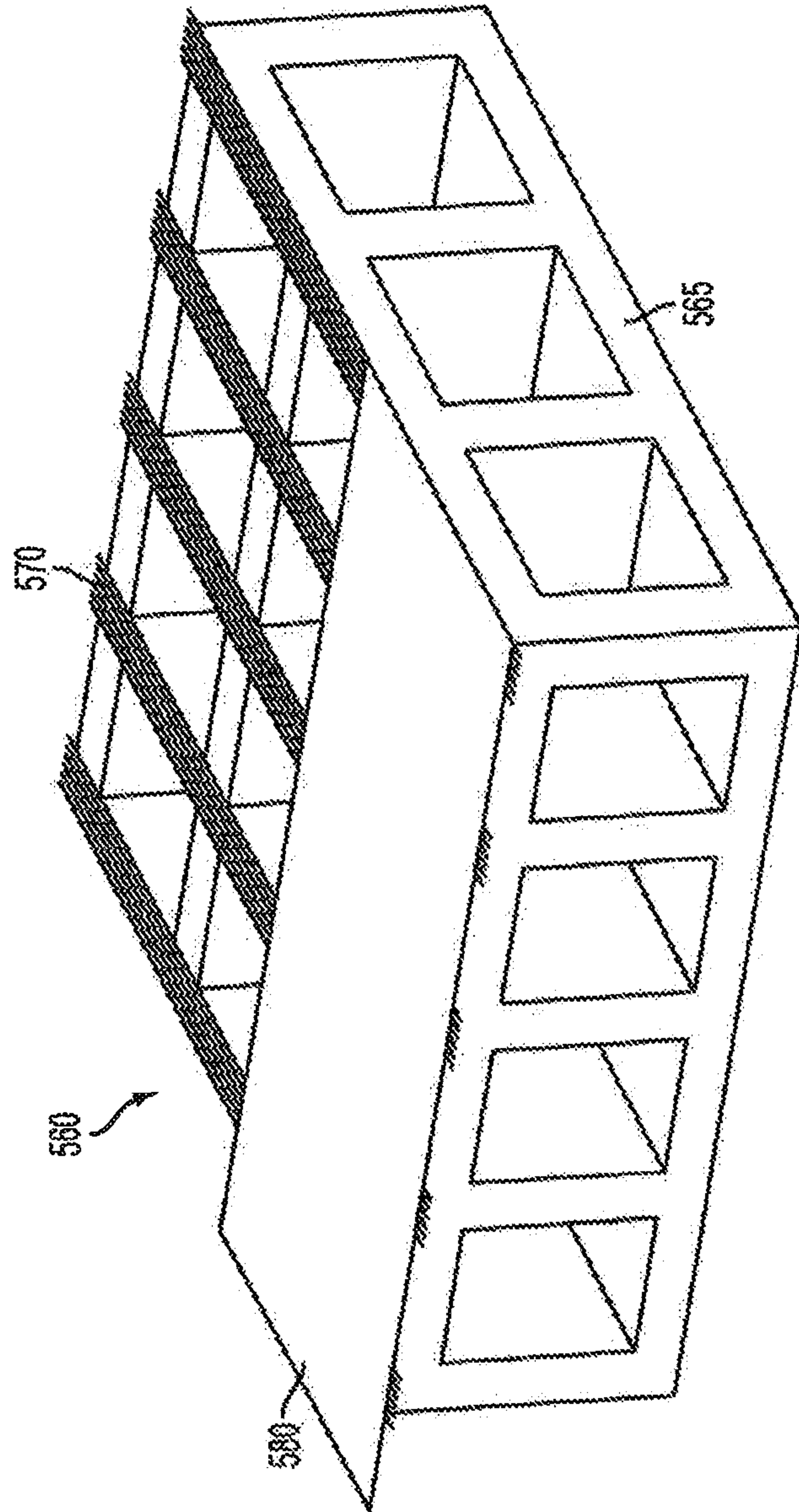

FIG. 5B

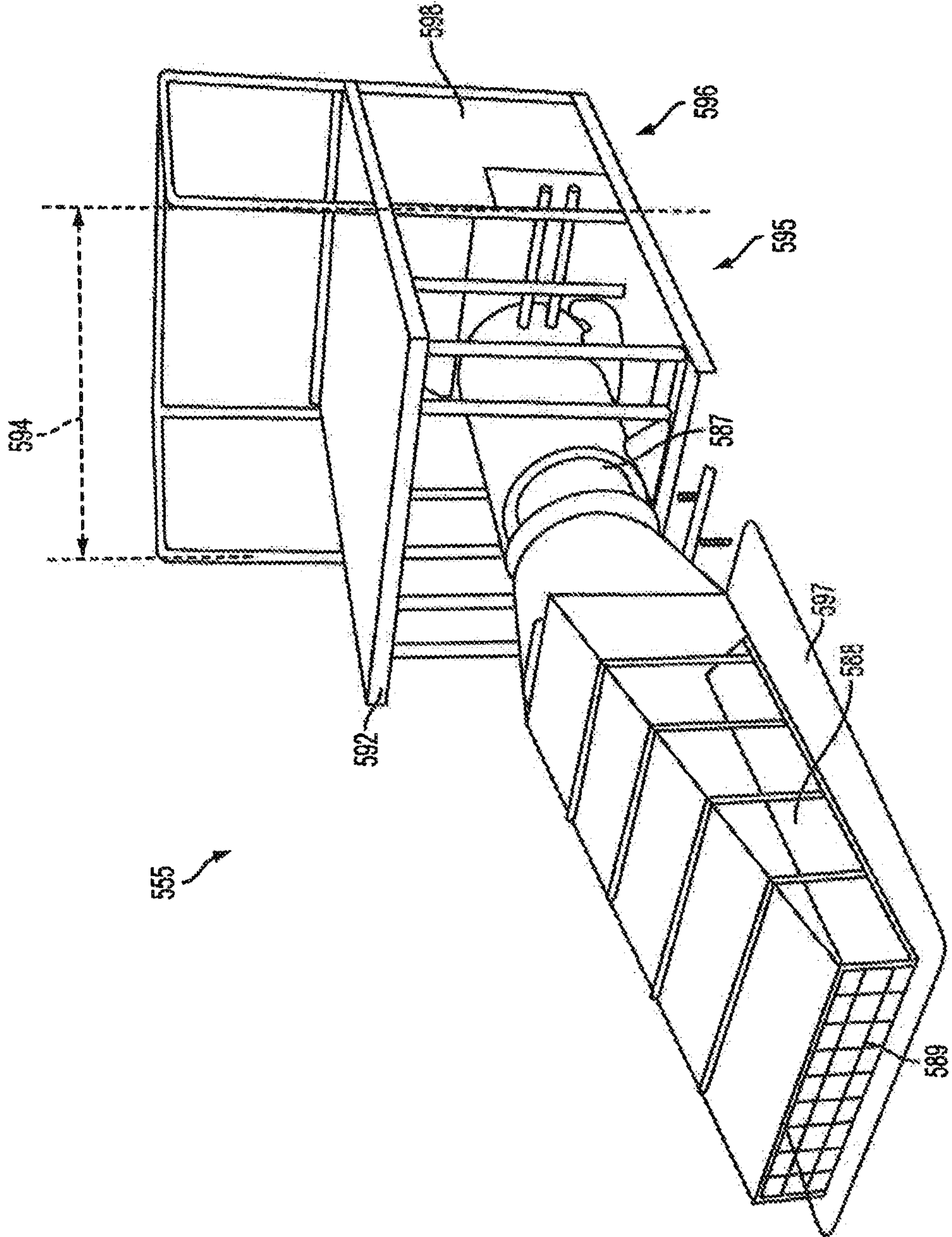

FIG. 5C

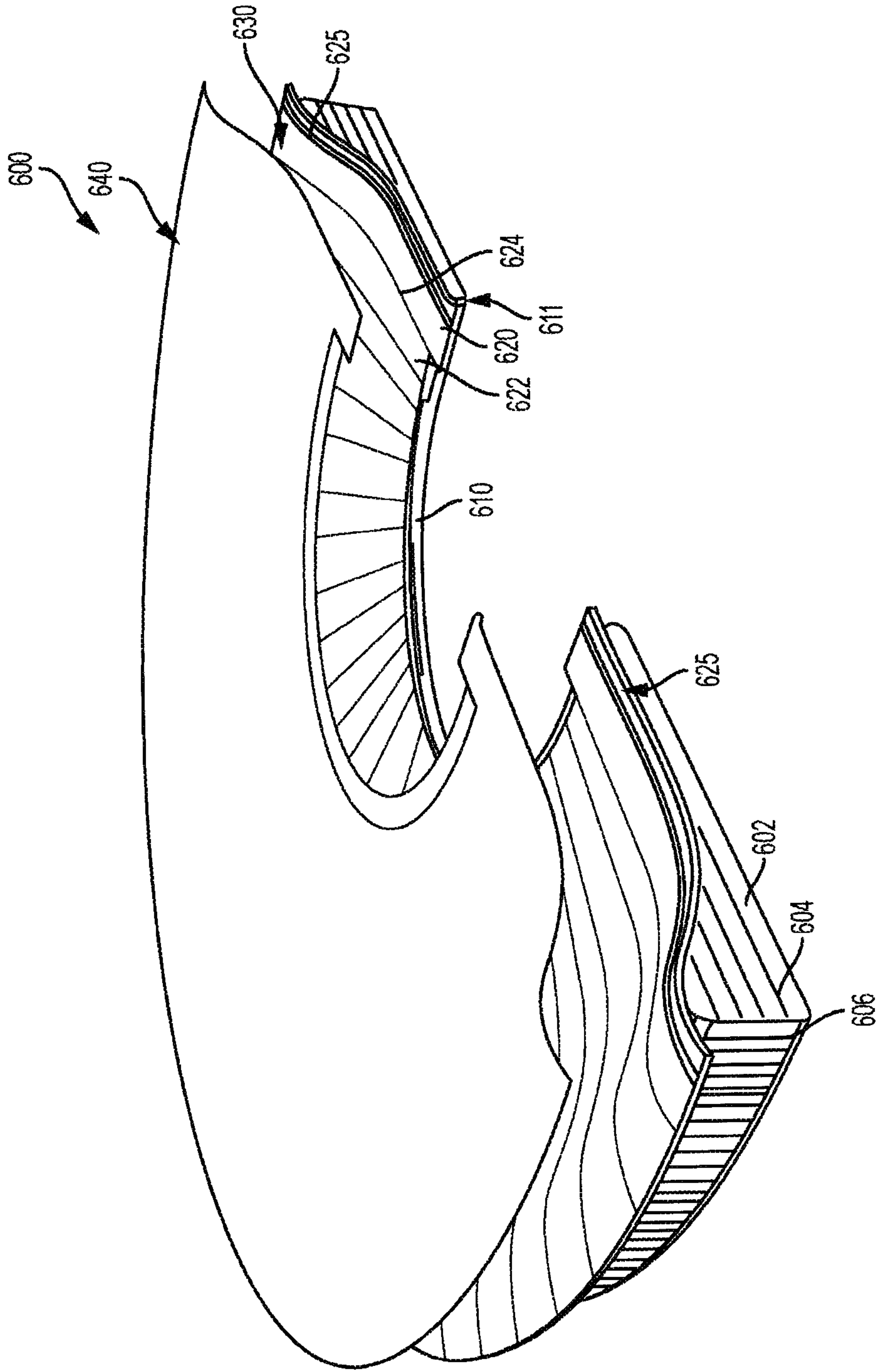

FIG. 6A

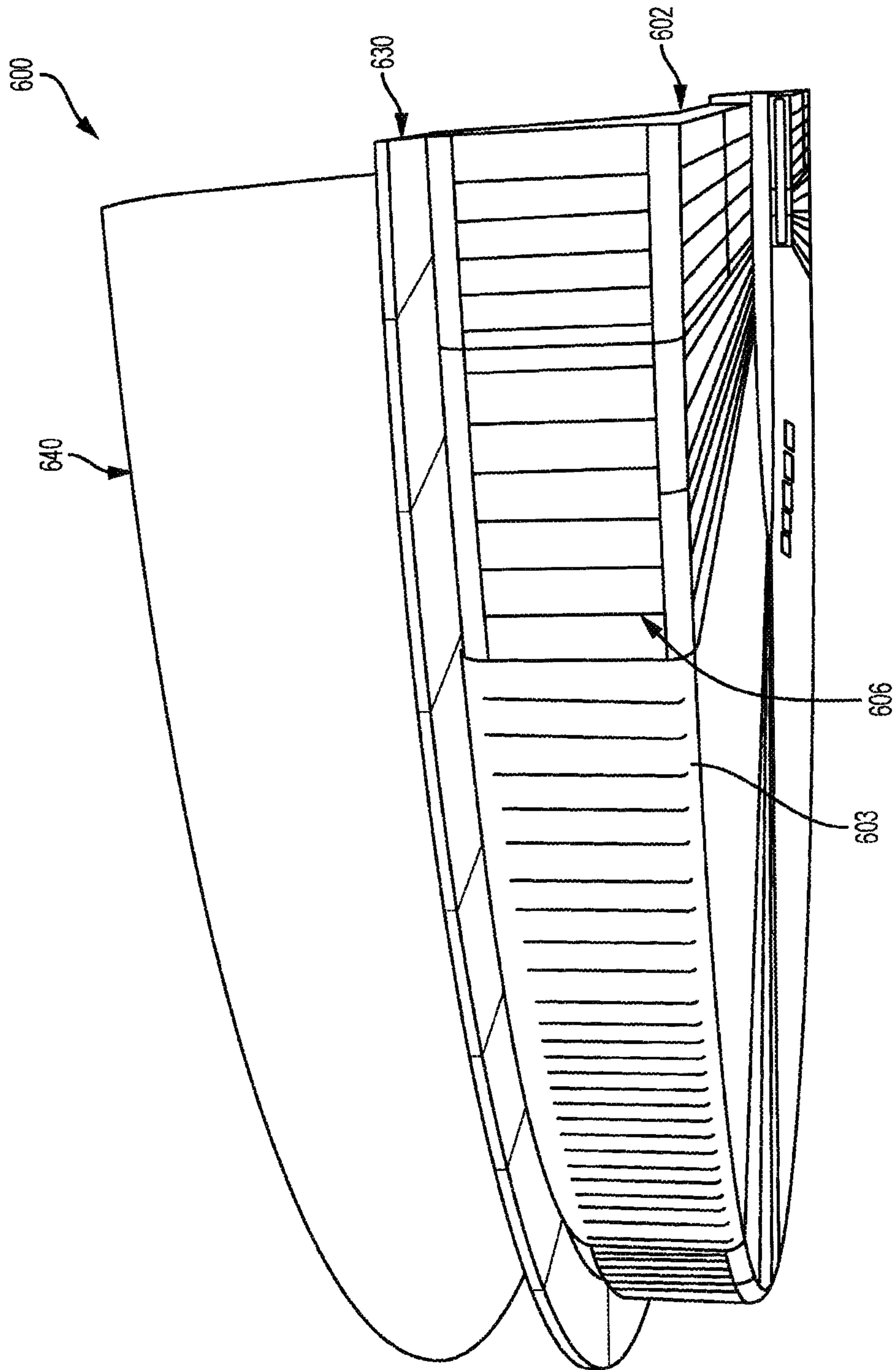

FIG. 6B

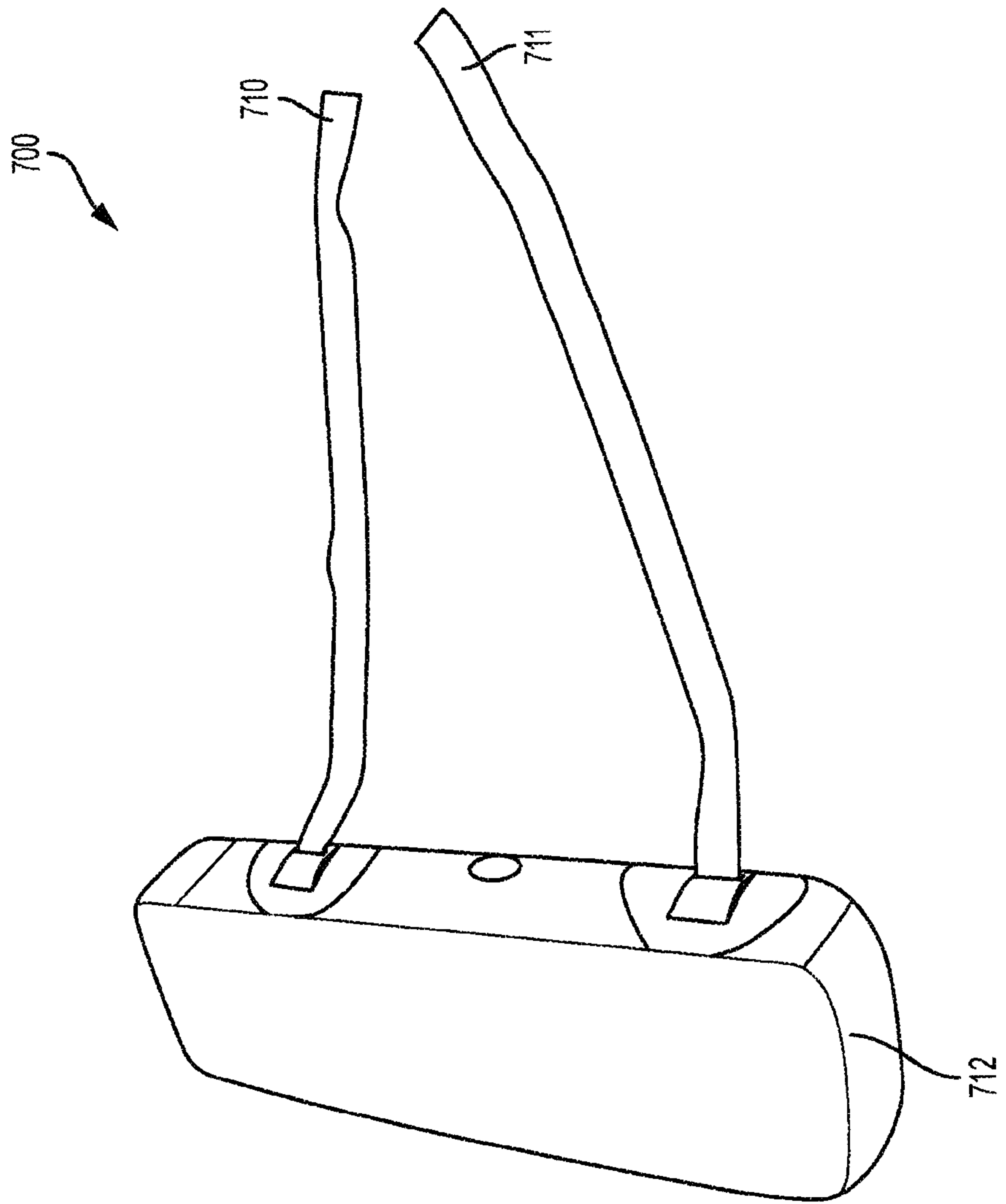

FIG. 7

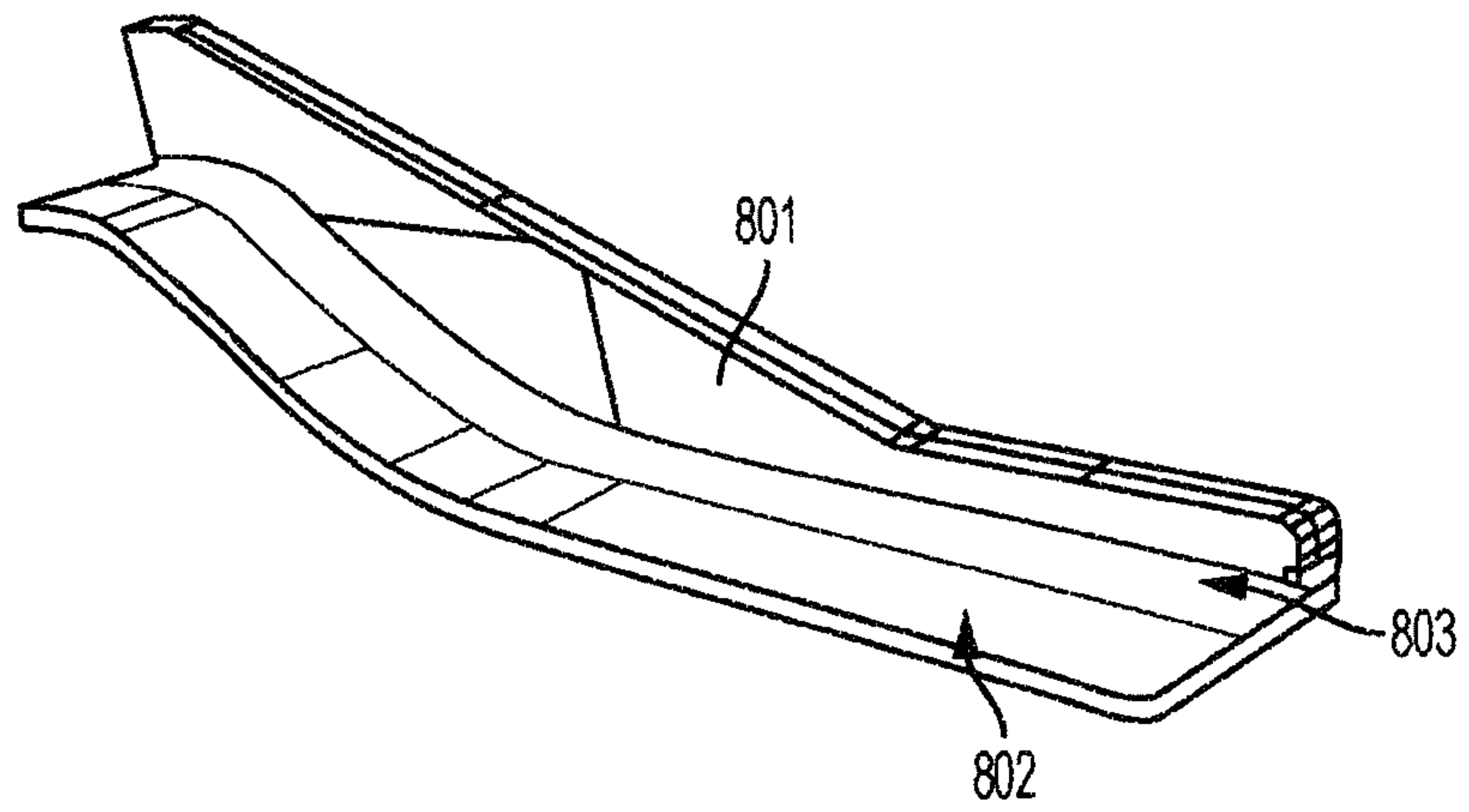

FIG. 8A

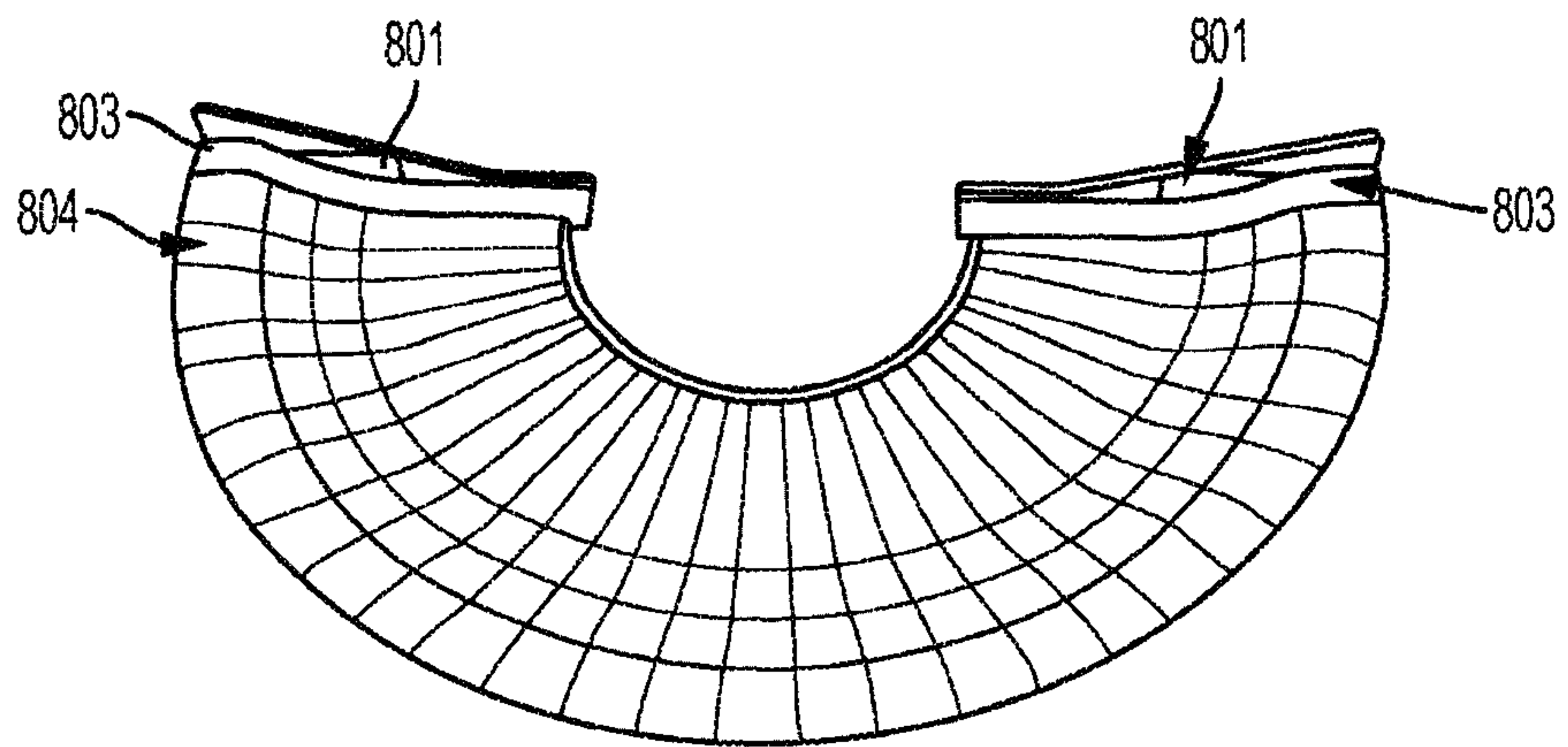

FIG. 8B

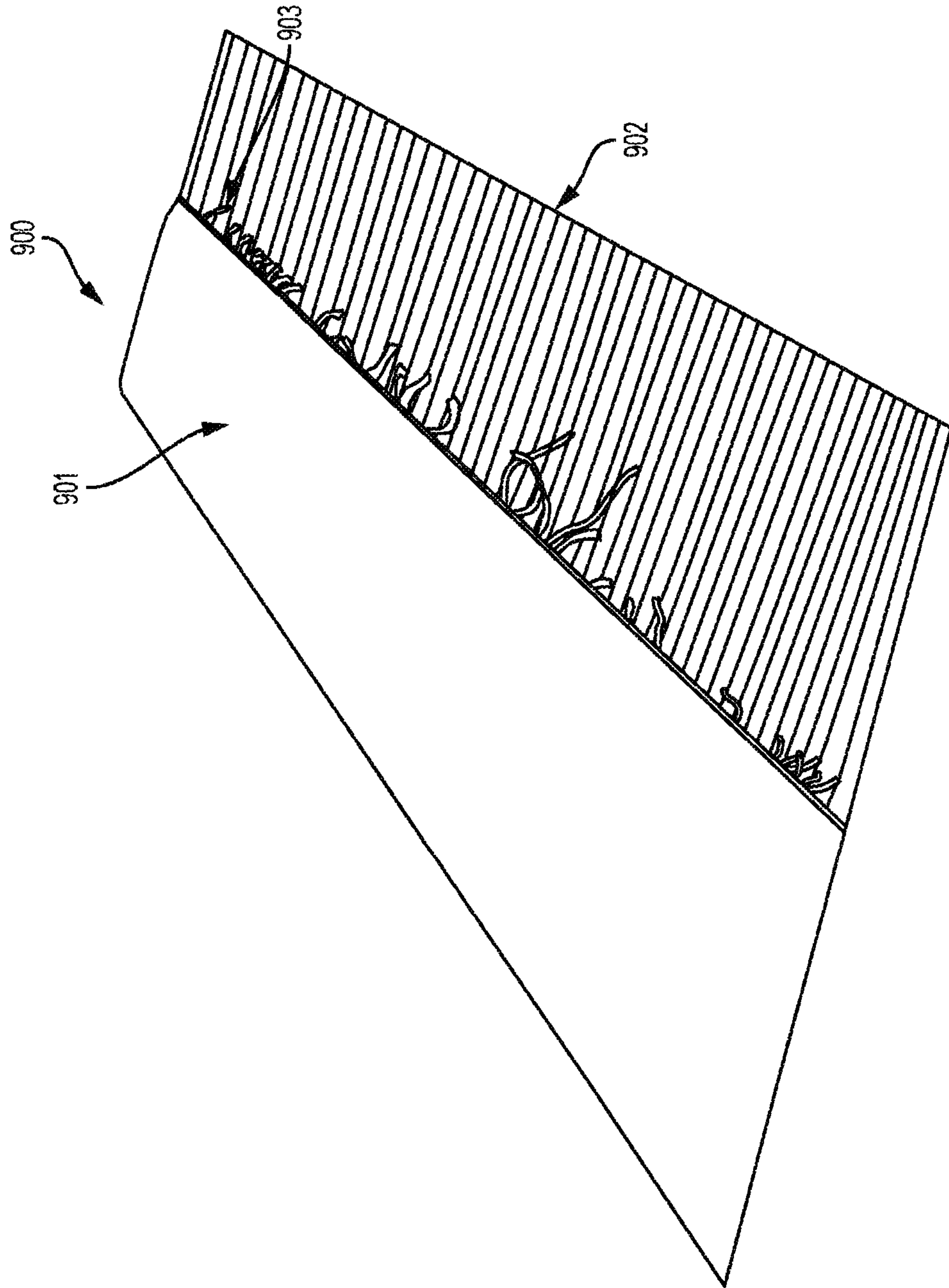

FIG. 9

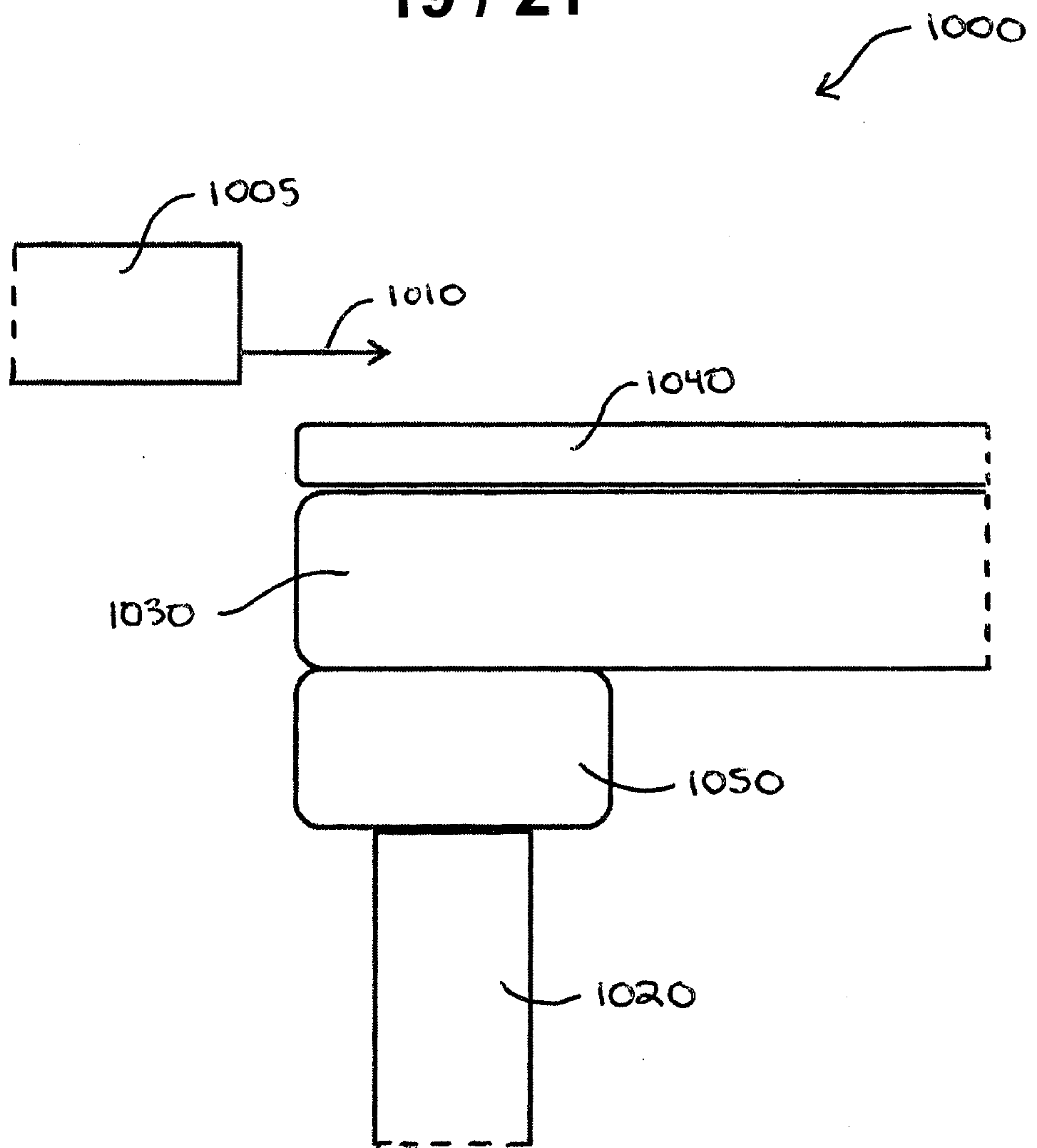

FIG. 10

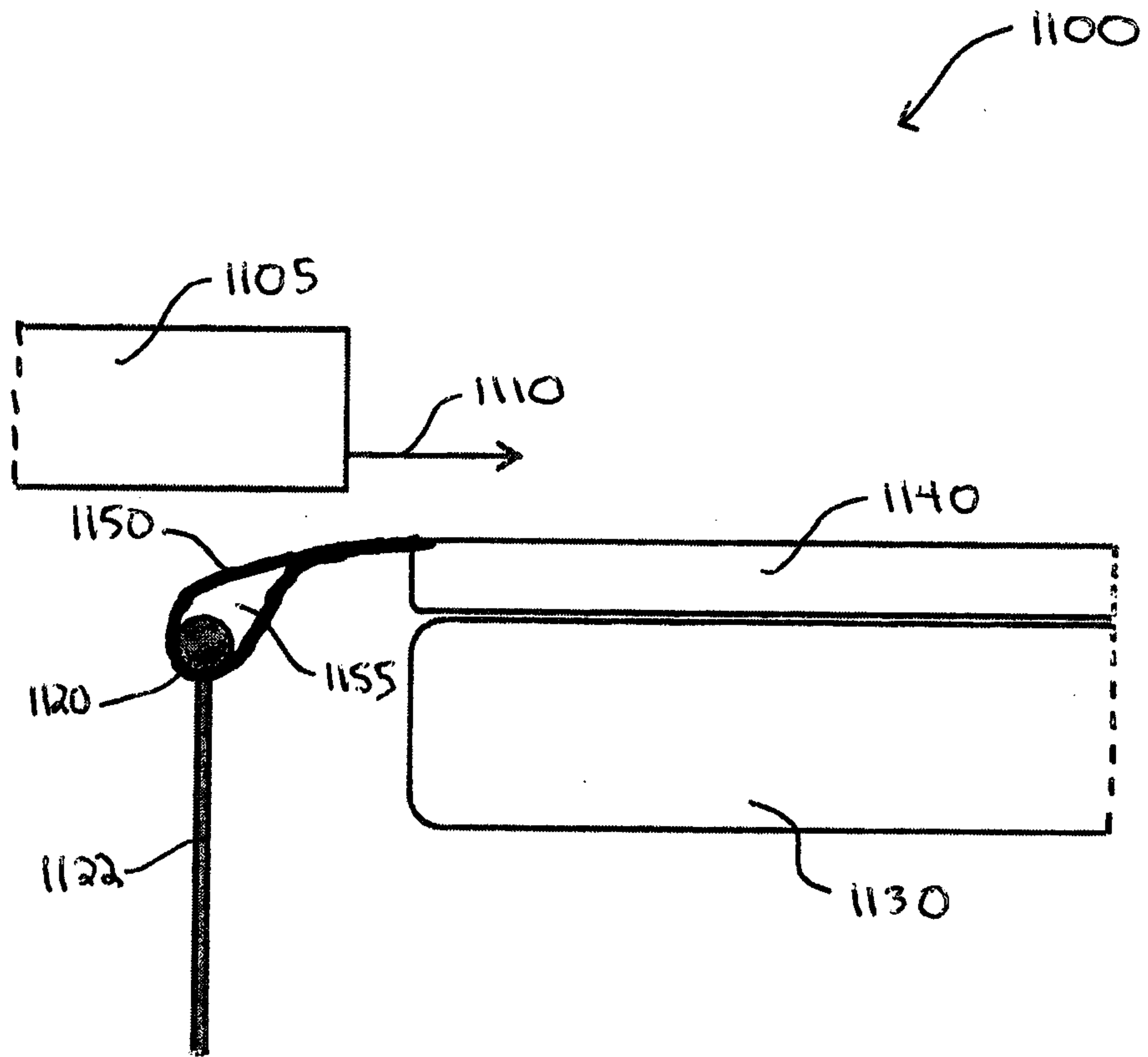

FIG. 11

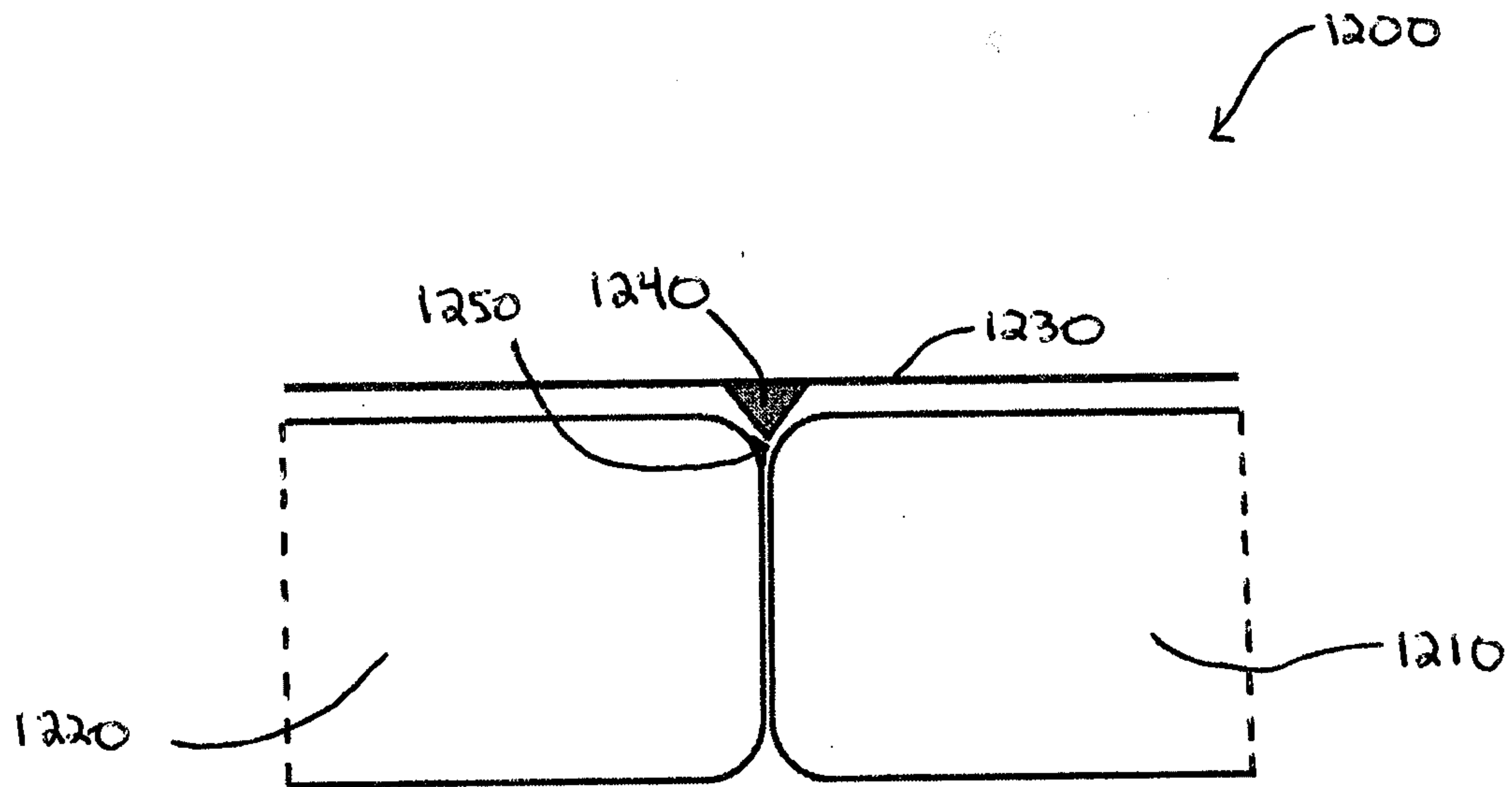

FIG. 12

