

Feb. 18, 1930.

R. W. ERSKINE
BRIDGE LIGHT UNIT
Filed Aug. 22, 1928

1,747,506

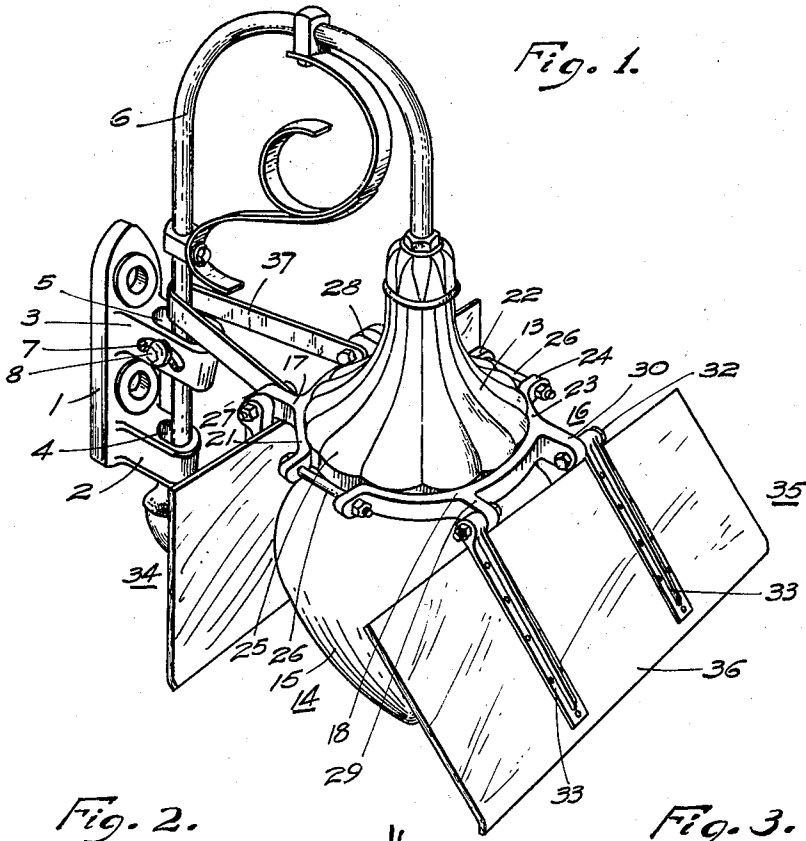

Fig. 1.

Fig. 2.

Fig. 3.

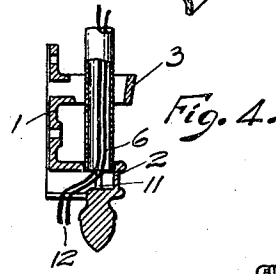
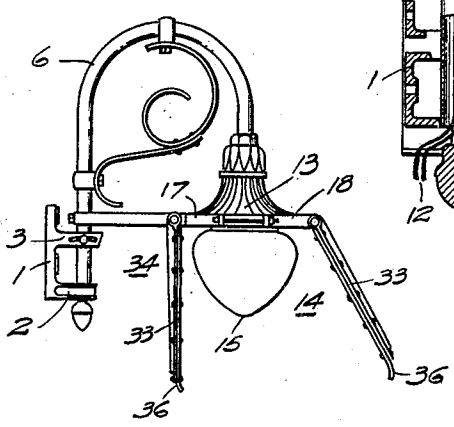
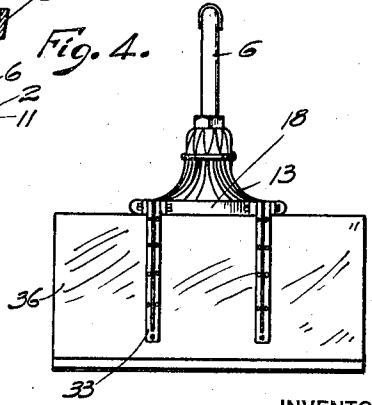

Fig. 4.



INVENTOR
Ralph W. Erskine
BY
Wesley S. Carr
ATTORNEY

UNITED STATES PATENT OFFICE

RALPH W. ERSKINE, OF MISHAWAKA, INDIANA, ASSIGNOR TO WESTINGHOUSE ELECTRIC & MANUFACTURING COMPANY, A CORPORATION OF PENNSYLVANIA

BRIDGE-LIGHT UNIT

Application filed August 22, 1928. Serial No. 301,272.

My invention refers to the art of illumination and has particular reference to lighting units adapted to light certain predetermined areas of other than circular shape.

5 An object of my invention is to provide a device for lighting a predetermined area as, for instance, the roadway of a bridge, or which will shield certain areas from illumination.

10 Another object of my invention is to provide a device of the above character which may be applied to the ordinary street-lighting units already installed.

Referring to the drawing, in which like figures indicate like parts:

Figure 1 is a view, in perspective, of a lighting unit which utilizes my device;

Fig. 2 is a side elevational view of the unit and device shown in Fig. 1;

20 Fig. 3 is an end elevational view of the device shown in Figs. 1 and 2, and,

Fig. 4 is a view, in section, of the supporting bracket and supporting crook of the lighting device showing my new method for introducing concealed wiring from the bracket into the crook.

Referring to the drawings, in practicing my invention, I provide a supporting bracket 1 adapted to be engaged to a wall, a pole or other supporting standard. The bracket is provided with two outwardly extending arms 2 and 3, one of which (2) is provided with a cup-shaped depression 4 and the other (3) with a longitudinally slotted vertical opening 5 for engaging and supporting the supporting crook 6.

A horizontally slotted opening 7 is provided in the side of the upper arm 3 of bracket 1, and a bolt 8 engages the side of the bracket and the crook to prevent the crook from oscillating or rotating and also to provide a certain amount of in and out adjustment.

The wiring for the lighting unit is concealed and is introduced through openings in the bracket and lower supporting arm (Fig. 4) and into the crook. This is accomplished by providing two inwardly extending shoulders 11 (Fig. 4) on the inside of the cup-shaped depression so that the end of the

crook rests upon the shoulders, and the conductors 12 may be introduced between the shoulders and into the crook. The crook 6 is a pipe adapted for carrying concealed wiring therein and a canopy 13, of the usual type, is fastened to the end of the crook. A lighting unit 14, comprising a globe 15, in which the light source is housed, is fastened to the canopy.

The shade structure 16 of my device comprises two clamps 17 and 18 of H-shape. One side of each clamp and two of the arms 21 and 22, 23 and 24, thereof, are adapted to engage the flange 25 of the canopy and are secured thereto by means of bolts 26. Two other arms 27 and 28, 29 and 30, on each of the clamps, are provided with bolts 32 for engaging arms 33 of the shades 34 and 35. The shades comprise plates 36 which may be provided with either a black or roughened surface for absorbing the light or may be provided with a reflecting surface which will reflect light emanating from the lighting unit.

In order to prevent movement of the clamps about the canopy, a brace 37 is provided which engages the crook just above the supporting bracket and is bolted thereto. The ends of the brace are secured to two of the arms of clamp 17. The arms of the shades are adjustably secured to the clamps so that the shades may be adjusted at any angle with the lighting unit.

If, for instance, the lighting unit is secured to a column at the side of a bridge or like structure, the inner shade 34 may be fastened in a nearly vertical position such that light is directed at only a small angle with the vertical, as shown in Fig. 1, while the outer shade may be adjusted at an angle with the vertical such that the light will be projected at an angle great enough to illuminate the far side of the bridge. If for instance, the lighting unit were mounted in close proximity to an apartment house or the like, it would be very desirable that a shade be located in such manner as to prevent light from being projected into the windows. Numerous other applications of my device will suggest themselves.

Although I have described a specific form

of my device, modifications may be made by those skilled in the art. I desire, therefore, that limitations be imposed only as defined in the appended claims.

I claim as my invention:

5 1. In combination with a lighting unit comprising a canopy and a globe, a shade structure comprising two H-shaped clamps each having four arms, two arms of each
10 clamp being adapted to engage the canopy, and shades fastened to the two remaining arms at each clamp.

15 2. In combination with a lighting unit comprising a supporting bracket, a supporting crook and a canopy, globe and lamp supported thereby, a shade structure comprising
clamps for engaging the canopy, shades engaged on the clamps and a brace engaging
one of the clamps and the crook.

20 In testimony whereof, I have hereunto subscribed my name this 8th day of August, 1928:

RALPH W. ERSKINE.

25

30

35

40

45

50

55

60

65