



(86) Date de dépôt PCT/PCT Filing Date: 2016/03/21
 (87) Date publication PCT/PCT Publication Date: 2016/09/29
 (85) Entrée phase nationale/National Entry: 2017/08/17
 (86) N° demande PCT/PCT Application No.: US 2016/023419
 (87) N° publication PCT/PCT Publication No.: 2016/154114
 (30) Priorité/Priority: 2015/03/25 (US62/138,002)

(51) Cl.Int./Int.Cl. *A23B 4/044* (2006.01),
A23B 4/052 (2006.01), *A23B 4/056* (2006.01),
A47J 37/06 (2006.01), *A47J 37/07* (2006.01)
 (71) Demandeur/Applicant:
 W.C. BRADLEY CO., US
 (72) Inventeurs/Inventors:
 DIXON, WILLIAM A., US;
 ABDALLAH, SLEIMAN ASSAAD, US;
 MCQUAGG, MARK STEPHEN, US
 (74) Agent: MACRAE & CO.

(54) Titre : CUISEUR ELECTRIQUE VERTICAL, FUMOIR ET BOITE A FUMEE
 (54) Title: VERTICAL ELECTRIC COOKER AND SMOKER AND SMOKE BOX

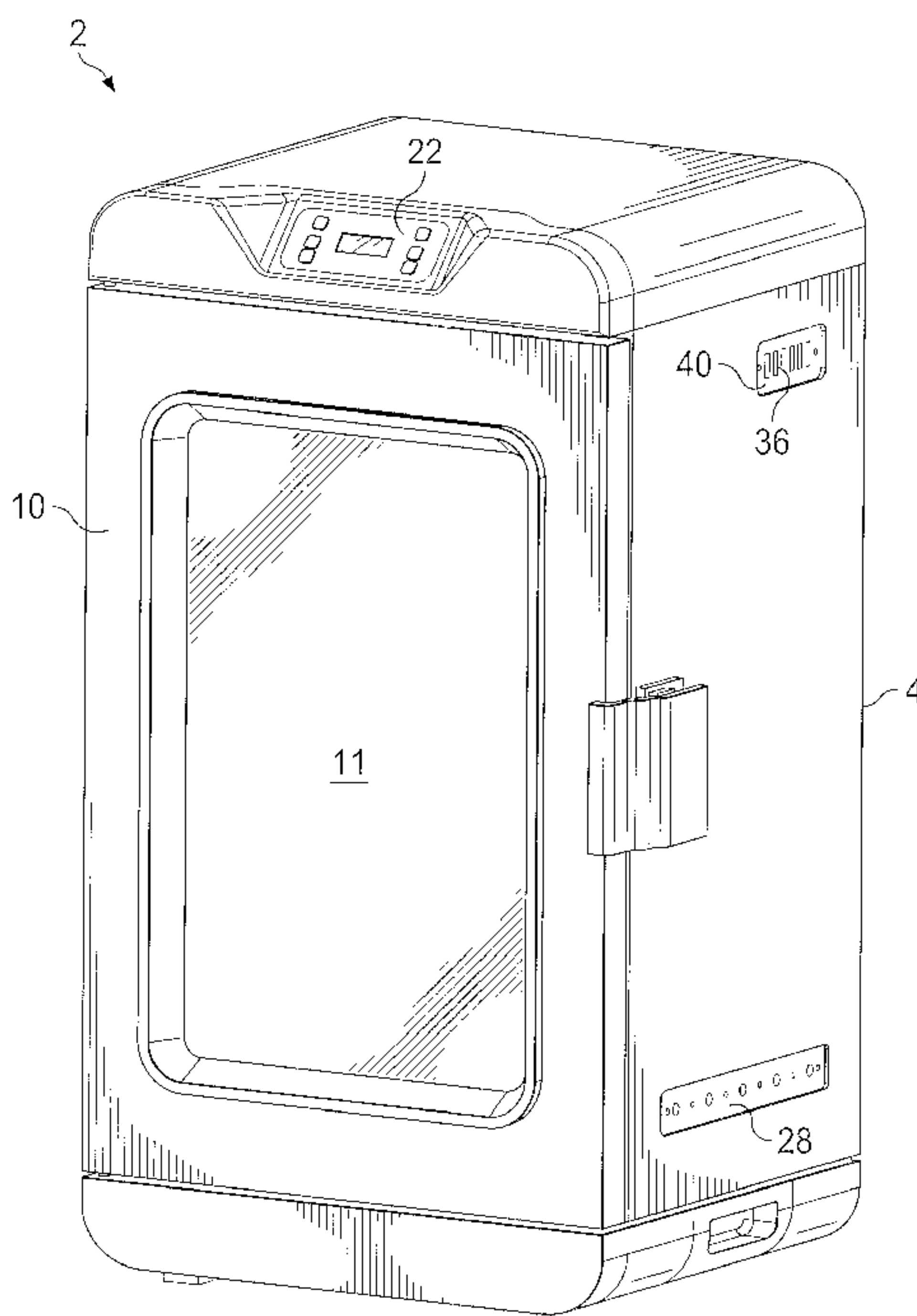

FIG. 1

(57) **Abrégé/Abstract:**

A vertical electric cooker and smoker having lower air intake vents and upper exhaust vents which together create a more balanced flow and distribution of smoke and reduce the operating pressure of the system to allow a much larger load of wood chips to be used without refilling. A smoke box is also provided for holding and properly combusting the larger quantity of wood chips in an oxygen deficient environment. The smoke box has a false bottom and discharges the smoke through a circuitous exhaust flow path. Also, the electric heating elements of the cooking and smoking apparatus are contained in an assembly which provides an air gap beneath the smoker box and also shields the smoker box to prevent the wood chips in the smoker box from becoming overheated.

(12) INTERNATIONAL APPLICATION PUBLISHED UNDER THE PATENT COOPERATION TREATY (PCT)

(19) World Intellectual Property
Organization
International Bureau(10) International Publication Number
WO 2016/154114 A1(43) International Publication Date
29 September 2016 (29.09.2016)

(51) International Patent Classification:

A23B 4/044 (2006.01) A47J 37/06 (2006.01)
A23B 4/052 (2006.01) A47J 37/07 (2006.01)
A23B 4/056 (2006.01)

(21) International Application Number:

PCT/US2016/023419

(22) International Filing Date:

21 March 2016 (21.03.2016)

(25) Filing Language:

English

(26) Publication Language:

English

(30) Priority Data:

62/138,002 25 March 2015 (25.03.2015) US

(71) Applicant: **W.C. BRADLEY CO.** [US/US]; 1017 Front Avenue, Columbus, GA 31902 (US).(72) Inventors: **DIXON, William, A.**; 7153 Village Loop, Columbus, GA 31904 (US). **ABDALLAH, Sleiman, As-saad**; 8748 Heiferhorn Way, Columbus, GA 31904 (US).**MCQUAGG, Mark, Stephen**; 8850 Veterans Parkway, Midland, GA 31820 (US).(74) Agent: **BROWN, Dennis, D.**; Brown Patent Law, P.L.L.C., 2700 N. Hemlock Ct., Suite 111 E, Broken Arrow, OK 74012 (US).

(81) Designated States (unless otherwise indicated, for every kind of national protection available): AE, AG, AL, AM, AO, AT, AU, AZ, BA, BB, BG, BH, BN, BR, BW, BY, BZ, CA, CH, CL, CN, CO, CR, CU, CZ, DE, DK, DM, DO, DZ, EC, EE, EG, ES, FI, GB, GD, GE, GH, GM, GT, HN, HR, HU, ID, IL, IN, IR, IS, JP, KE, KG, KN, KP, KR, KZ, LA, LC, LK, LR, LS, LU, LY, MA, MD, ME, MG, MK, MN, MW, MX, MY, MZ, NA, NG, NI, NO, NZ, OM, PA, PE, PG, PH, PL, PT, QA, RO, RS, RU, RW, SA, SC, SD, SE, SG, SK, SL, SM, ST, SV, SY, TH, TJ, TM, TN, TR, TT, TZ, UA, UG, US, UZ, VC, VN, ZA, ZM, ZW.

(84) Designated States (unless otherwise indicated, for every kind of regional protection available): ARIPO (BW, GH, GM, KE, LR, LS, MW, MZ, NA, RW, SD, SL, ST, SZ,

[Continued on next page]

(54) Title: VERTICAL ELECTRIC COOKER AND SMOKER AND SMOKE BOX

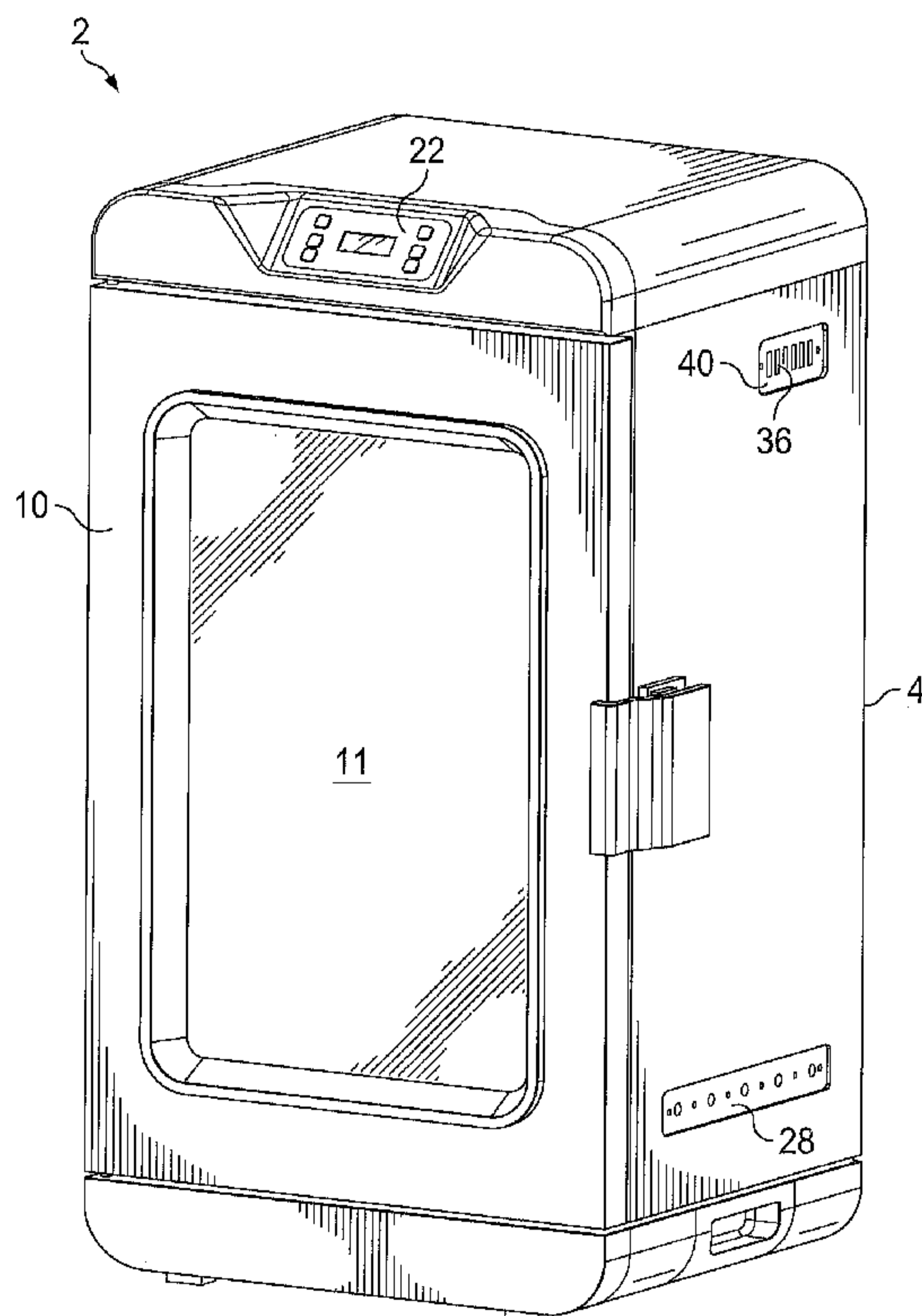

FIG. 1

(57) Abstract: A vertical electric cooker and smoker having lower air intake vents and upper exhaust vents which together create a more balanced flow and distribution of smoke and reduce the operating pressure of the system to allow a much larger load of wood chips to be used without refilling. A smoke box is also provided for holding and properly combusting the larger quantity of wood chips in an oxygen deficient environment. The smoke box has a false bottom and discharges the smoke through a circuitous exhaust flow path. Also, the electric heating elements of the cooking and smoking apparatus are contained in an assembly which provides an air gap beneath the smoker box and also shields the smoker box to prevent the wood chips in the smoker box from becoming overheated.

WO 2016/154114 A1 

TZ, UG, ZM, ZW), Eurasian (AM, AZ, BY, KG, KZ, RU, TJ, TM), European (AL, AT, BE, BG, CH, CY, CZ, DE, DK, EE, ES, FI, FR, GB, GR, HR, HU, IE, IS, IT, LT, LU, LV, MC, MK, MT, NL, NO, PL, PT, RO, RS, SE, SI, SK, SM, TR), OAPI (BF, BJ, CF, CG, CI, CM, GA, GN, GQ, GW, KM, ML, MR, NE, SN, TD, TG).

Declarations under Rule 4.17:

- *as to applicant's entitlement to apply for and be granted a patent (Rule 4.17(ii))*

- *as to the applicant's entitlement to claim the priority of the earlier application (Rule 4.17(iii))*

Published:

- *with international search report (Art. 21(3))*
- *before the expiration of the time limit for amending the claims and to be republished in the event of receipt of amendments (Rule 48.2(h))*

VERTICAL ELECTRIC COOKER AND SMOKER AND SMOKE BOX

RELATED CASE

[0001] This application claims the benefit of U.S. Provisional Patent Application
5 Serial No. 62/138,002 filed on March 25, 2015 and incorporates said provisional
application by reference into this document as if fully set out at this point.

FIELD OF THE INVENTION

[0002] The present invention relates to vertical electric apparatuses for cooking and
smoking and to smoke generation devices and systems for such apparatuses.

10

BACKGROUND OF THE INVENTION

[0003] A vertical electric smoker typically comprises: a vertical box-type cooking and
smoking chamber; a vertical front door for the cooking chamber; and an internal electric
element. The electrical element is typically used for both (a) heating the interior of the
cooking chamber for cooking the food and (b) heating a small amount of wood (e.g.,
15 wood chips, pellets, or other pieces) to generate smoke within the cooking chamber.
Often the vertical box will be built with insulated walls, a window in the door, and
electronic controls, including a remote control in some cases. Also, a single exhaust vent
is typically provided in or near the top of the vertical box to allow the smoke to flow out
of the cooking chamber after contacting the food.

20 [0004] Examples of prior vertical electric smokers are shown in US Patent Nos.
D615798, D616243, and 7,426,885. In the vertical electric smoker of US Patent No.
7,426,885, wood chips are placed in a loading trough which is inserted through an
opening in the side of the cooking chamber. In this arrangement, multiple small amounts
of wood chips, typically limited to less than one cup, must be added during the course of
25 the cooking and smoking process.

[0005] Consequently, when using a prior vertical electric smoker of the type shown in
US Patent No. 7,426,885 for smoking multiple large pieces of food in the cooking
chamber over a lengthy, slow cooking cycle, the user must frequently assess, typically by
visual observation of the amount and color of the smoke flowing out of the cooking and
30 smoking chamber, when a new load of wood chips is needed. Then, to add each new load
of wood chips, the user must withdraw the wood loading trough, refill the trough with a
small fresh load of wood chips, and reinsert the loading trough into the cooking chamber.

[0006] Because this reloading process may need to be repeated multiple times during a slow cooking and smoking cycle, a considerable amount of time and attention is required. Also, the amount of smoke generated within the cooking chamber is cyclical such that (a) the amount of smoke generated for at least several minutes prior to replacing a spent load of wood chips can be undesirably low and (b) little or no smoke will be initially generated for several minutes after a fresh load of wood chips is inserted.

[0007] To complete the entire cooking and smoking process without having to repeatedly replace the wood chips, the amount of wood chips placed in the cooking and smoking chamber at the beginning of the cooking cycle would have to be up to four times or more greater than the amount of wood chips currently used in each of the small individual loads. Unfortunately, however, placing such a large load of wood chips or pellets in close proximity to the electric heating element for the purpose of producing smoke will create various problems.

[0008] First, placing such a large amount of fuel in close proximity to the heat source can cause fires inside the cooking chamber. Second, even if the fire is suppressed, a higher rate of combustion will still be produced which will use up the wood more quickly while also generating more heat than smoke. Third, associated with the second problem, an undesirable amount of dense smoke can build up inside the cooking chamber and create an unfavorable cooking environment which can lead to, among other things, the excessive condensation of smoke and water vapor from the combustion process onto the relatively cold meat or other food products within the cooking and smoking chamber.

SUMMARY OF THE INVENTION

[0009] The present invention satisfies the needs and alleviates the problems discussed above.

[0010] In one aspect, a vertical, electrically-heated apparatus for cooking and smoking is provided wherein at least one air intake vent is provided in the lower portion of the cooking and smoking chamber of the apparatus and at least one exhaust vent is provided in the upper portion of the cooking and smoking chamber. Preferably, the apparatus comprises a pair of lower air intake vents on opposite sides of the cooking and smoking chamber and a pair of upper exhaust vents on opposite sides of the cooking and smoking chamber.

[0011] This inventive venting arrangement unexpectedly and surprisingly operates to:
(a) create a balanced flow of ventilating air through the cooking and smoking chamber,
thus providing a more even distribution of smoke and heat inside the chamber; (b) reduce
the amount of CO₂ produced in the apparatus; (c) only slightly reduce the temperature in
5 the cooking and smoking chamber for the first hour of operation, after which the
temperature is comparable; (d) consistently produce a desired concentration of smoke
which is not overly dark or dense; (e) reduce the amount of condensation of smoke and
water vapor on the surface of the food; (f) reduce the operating pressure within the
cooking and smoking chamber to allow a much larger load of wood chips to be placed in
10 the apparatus; and (g) more evenly fill the chamber with smoke without any voids in the
cooking and smoking zone.

[0012] In another aspect, an improved heating element assembly is provided
comprising: (a) a tray which holds one or more electric heating elements for the cooking
and smoking apparatus and (b) a smoke box retaining station. The retaining station
15 receives the bottom of the smoke box (i.e., the container in which the wood chips or other
wood pieces are held and burned to produce smoke) and holds the smoke box above the
electric heating element(s). The retaining station preferably comprises: (a) a cover plate
which at least partially covers the electric heating element(s) and acts as a bottom plate
for the retaining station; (b) a plurality of spacers (stand-offs) projecting from the upper
20 surface of the cover plate to create an air gap between the cover plate and the bottom of
the smoke box; and (c) a reflector which extends rearwardly from the receiving station for
shielding the back of the smoke box.

[0013] These features of the heating element assembly operate to (a) reduce the
temperature and heat transfer at the bottom of the smoke box sufficiently to increase
25 smoke time, (b) provide even heating of the wood chips in the entire lower layer inside
the box so that the chips start at the same time, and (c) eliminate hot pockets within the
smoke box.

[0014] In another aspect, an improved smoke box is provided for holding the wood
chips or other pieces and slowly combusting the wood in an oxygen starved environment
30 to produce wood smoke for use in the cooking and smoking chamber of the inventive
apparatus. The smoke box has a false bottom which creates an internal gap in the
container beneath the wood chips. In addition, either the lid of the smoke box, one or
more vertical side walls of the box, or a combination thereof include(s) an exhaust flow

assembly which defines a circuitous flow path wherein the smoke is required to flow through an inner flow gap (horizontal or vertical) and then change directions and flow through an outer flow gap (horizontal or vertical) as it travels to the smoke exhaust opening(s). Additionally, one or more obstructing structures (e.g., flow rail pieces with offset flow ports as discussed below) are preferably provided in each of the inner and outer flow gaps to cause the smoke to also change direction to at least some degree as it flows from one end of the flow gap to the other.

[0015] This circuitous path for discharging the smoke product from the smoke box acts as a flame suppression mechanism to prevent and contain any fire in the smoke box, and additionally provides for cooling and mixing of the smoke produced in the smoke box so that the discharged smoke product has a relatively uniform temperature and smoke concentration. The length of the circuitous path also allows for the smoke temperature to be hot enough to maintain suspension in the atmosphere but cool enough to stay well below any potential ignition point of the smoke when it exits from the smoke box.

[0016] Moreover, the beneficial features of the inventive smoke box operate together with the inventive venting arrangement for the cooking and smoking chamber and the novel features of the inventive heating element assembly to allow a sufficient amount of wood chips to be placed in the smoke box to complete the cooking and smoking operation without reloading.

[0017] In another aspect, there is provided an apparatus for cooking and smoking food comprising: (a) a vertically extending cooking and smoking chamber having a left side wall, a right side wall, a back wall, a front opening, and a bottom floor; (b) a door positionable on the front opening for closing and opening the front opening; (c) one or more air intake vents provided in a lower portion of the cooking and smoking chamber; (d) one or more exhaust vents provided in an upper portion of the cooking and smoking chamber; and (e) one or more electric heating elements positioned in the lower portion of the cooking and smoking chamber, the one or more electric heating elements being spaced above the bottom floor of the cooking and smoking chamber.

[0018] The apparatus preferably comprises two of the air intake vents and two of the exhaust vents wherein a first of the air intake vents is provide through a lower portion of the right side wall, a second of the air intake vents is provide through a lower portion of the left side wall, a first of the exhaust vents is provided through an upper portion of the

right side wall, and a second of the exhaust vents is provided through an upper portion of the left side wall. The first and the second air intake vents are preferably located at an elevation which is at or below an elevation of the electric heating element. In addition, the cooking and smoking chamber has an uppermost food support rack positioned therein and the first and the second exhaust vents are preferably positioned at an elevation above an elevation of the uppermost food support rack in the cooking and smoking chamber.

5 [0019] The apparatus also preferably comprises (a) a smoke box for generating smoke and (b) a smoke box placement station in the cooking and smoking chamber for placement of the smoke box at least partially over the one or more electric heating elements. Preferably, the apparatus further comprises an element tray in which the one or more electric heating elements are positioned, the element tray being spaced above the bottom floor of the cooking and smoking chamber. In addition, the smoke box placement station preferably comprises (i) a cover plate on the element tray which at least partially covers the one or more electric heating elements and (ii) a plurality of spacing elements on an upper surface of the cover plate on which the smoke box is placeable to provide an air gap between a bottom of the smoke box and the cover plate.

10 [0020] The element tray of the apparatus also preferably has a reflective upper surface positioned beneath the one or more electric heating elements. Further, the apparatus preferably includes (a) an air gap between the element tray and the back wall of the cooking and smoking chamber and (b) a horizontal reflector plate extending rearwardly from the element tray toward the back wall of the cooking and smoking chamber which shields a vertical back side of the smoke box from radiant energy which is emitted from the one or more electric heating elements, reflected from the reflective upper surface of the element tray, or both.

15 [0021] In another aspect, there is provided a smoke box apparatus which can be used in the inventive smoker or can be used in other applications. The inventive smoke box apparatus preferably comprises: (a) a container having an interior combustion area for combusting wood chips or other pieces in an oxygen deficient environment to produce smoke and (b) an exhaust flow assembly which defines a circuitous exhaust flow path for the smoke wherein the smoke must flow in a first direction through an inner flow gap formed by the exhaust flow assembly and then must flow in a second direction, different from the first direction, through an outer flow gap formed by the exhaust flow assembly.

[0022] The container of the inventive smoke box also preferably has a false bottom which is positioned in the container at the bottom of the interior combustion area, the false bottom being spaced above the actual bottom of the container such that a bottom air space is defined between the false bottom and the actual bottom of the container.

5 [0023] In addition, the exhaust flow assembly of the inventive smoke box preferably further includes: (i) a first obstructing structure in the inner flow gap which at least momentarily alters the flow path of the smoke as the smoke travels from an inlet end to an outlet end of the inner flow gap and (ii) a second obstructing structure in the outer flow gap which at least momentarily alters the flow path of the smoke as the smoke travels
10 from an inlet end to an outlet end of the outer flow gap. The first and the second obstructing structures preferably each comprise an upstream rail and a parallel downstream rail, the upstream and the downstream rails each have a plurality of holes for flow of the smoke through the rails wherein the holes of the downstream rail are preferably not in alignment with the holes of the upstream rail.

15 [0024] The exhaust flow assembly of the inventive smoke box can be formed in a lid of the container. As another alternative, the exhaust flow assembly can be formed in a vertical side wall of the container. As yet another alternative, the exhaust flow assembly can be formed in a plurality of vertical side walls of the container.

[0025] Further aspects, features, and advantages of the present invention will be
20 apparent to those of ordinary skill in the art upon examining the accompanying drawings and upon reading the following detailed description of the preferred embodiments.

BRIEF DESCRIPTION OF THE DRAWINGS

[0026] FIG. 1 is a perspective view of an embodiment **2** of the vertical electric cooking and smoking apparatus provided by the present invention.

25 [0027] FIG. 2 is a perspective view of the inventive vertical electric cooker and smoker **2** with the door **10** in open position to show the interior of the apparatus **2**.

[0028] FIG. 3 is a perspective view of an electrical heating element assembly **14** and an embodiment **18** of the smoke box provided by the present invention.

[0029] FIG. 4 is a cutaway elevational side view of the inventive smoke box **18**.

30 [0030] FIG. 5 is an elevational side view of a flow rail piece **110**, **112** used in the inventive smoke box **18**.

[0031] FIG. 6 is an exploded view of the inventive smoke box **18**.

[0032] FIG. 7 is a cutaway elevational side view of an alternative embodiment **150** of the inventive smoke box.

[0033] FIG. 8 is an exploded view of the inventive smoke box **150**

DETAILED DESCRIPTION OF THE PREFERRED EMBODIMENTS

5 [0034] An embodiment **2** of the vertical electric cooker and smoker provided by the present invention is shown in FIGS. 1 and 2. The inventive electric cooking and smoking apparatus **2** comprises: a vertical rectangular box **4** having a vertical front opening **6**; a cooking and smoking chamber **8** within the vertical box **4**; a vertical front door **10**, preferably having a window **11** therein, which is pivotably attached to the vertical box **4**
 10 for opening and sealingly closing the front opening **6** of the cooking and smoking chamber **8**; a plurality of food support racks **12** removably positionable in the cooking and smoking chamber **8**; an electrical heating element assembly **14** spaced above the floor **16** of the cooking and smoking chamber **8**; a smoke box **18** which is removably positionable on the heating element assembly **14**; a removable pan or other container **20** adjacent to the
 15 heating element assembly **14** for holding water or other liquid to maintain a desired level of moisture or flavorant vapor in the cooking and smoking chamber **8**; and an electronic display and control panel **22** at the top of the box **4** above the door **10** for controlling the electrical heating system and/or monitoring temperatures, cooking times, and/or other parameters within the cooking and smoking chamber **8** in any manner desired.

20 [0035] The multiple food support racks **12** will preferably be mounted on opposing stamped side plates **15**, using common formations found in indoor ovens for retaining cooking racks. However, this stamped detail **15** is preferably not integral with the side wall of the cooking and smoking chamber **8** as would be normal in an indoor oven, but is more preferably attached as a separate part as depicted for additional flexibility in the
 25 manufacturing and configuration of the inventive apparatus **2**.

[0036] As shown in FIGS. 1 and 2, two air intake vents **24** and **28** are provided in the lower portion of the cooking and smoking chamber **8**. One of the lower air intake vents **24** is provided through the left side wall **30** of the vertical box **4** and the other air intake vent **28** is provided through the right side wall **32** of the vertical box **4**, preferably directly
 30 opposite the left side intake vent **24**. The air intake vents **24** and **28** are preferably located in the side walls **30** and **32** at or below the elevation of the heating element assembly **14**.

[0037] Each of the side air intake vents **24** and **28** preferably comprises one opening (e.g., an elongate slot) or a series of openings **25** which (a) preferably extend(s) laterally in the side wall **30** or **32** of the vertical box **4** across at least 30% (more preferably across from about 75% to about 85%) of the width of the side wall **30** or **32** and (b) is preferably centered in the lower portion of the side wall **30** or **32**. Proportionally speaking, the total flow (opening) area provided by each of the air intake vents **24** and **28** is preferably in the range of from about 1.0 to about 4.0 inches², more preferably from about 2.0 to about 3.0 inches², per 2.94 ft³ of volume of the cooking and smoking chamber **8**. Although it is preferred that the air intake vents **24** and **28** not be adjustable, the inventive apparatus **2** can optionally include louvers, sliding covers, or other features for selectively changing the open area of the intake vents **24** and **28**.

[0038] As further shown in FIGS. 1 and 2, two exhaust vents **34** and **36** are provided in the upper portion of the cooking and smoking chamber **8**, preferably near the top end thereof above the uppermost food support rack **12**. Preferably, one of the upper exhaust vents **34** is provided through the left side wall **30** of the vertical box **4** and the other upper exhaust vent **36** is provided through the right side wall **32** of the vertical box **4**, preferably directly opposite the left side exhaust vent **34**.

[0039] Each of the exhaust vents **34** and **36** preferably (a) is located from about 1.5 to about 6.5 inches from the upper end of the cooking and smoking chamber **8**, (b) is located within from about 2.5 to about 4.5 inches from the back wall **38** of the cooking and smoking chamber **8**, (c) has a louvered exterior cover **40** which operates to direct smoke from the forward end **94** of the lid assembly **82** of the smoke box **18** up and through a plurality of food support racks **12**, and (d) provides a total effective proportional flow area, through the cover **40** if present, in the range of from about 4.0 to about 9.0 inches², more preferably from about 6.0 to about 7.0 inches², per 2.94 ft³ of volume of the cooking and smoking chamber **8**.

[0040] The inventive placement of the lower pair of air intake vents **24** and **28** and the upper pair of exhaust vents **34** and **36** on each side of the cooking smoking chamber **8** creates a balanced flow of ventilating air through the cooking and smoking chamber **8** on both sides, thus providing a more even distribution of smoke and heat inside the chamber **8**. The admission of cool, fresh outside air also reduces the production of CO₂, as shown in tests of the inventive apparatus **2**. In these tests, over the space of the first two hours of

operation, the exhaust from the inventive cooking and smoking chamber **8** had a CO₂ concentration of no more than 0.78%, normally between .10% and .15%. However, without the air intake vents **24** and **28**, a CO₂ concentration of up to 2.25 %, normally between 1.3% and 2.1%, was produced.

5 [0041] Moreover, these tests further showed that the cooling air flow provided by the inventive venting arrangement unexpectedly only slightly reduced the average internal temperature in the cooking and smoking chamber **8** for the first hour of operation, after which the temperatures were comparable. Although the reason for this surprising result is not known with certainty, it is believed to be the effect of the interior of the cooking and
10 smoking chamber **8** as a whole reaching a radiant heat equilibrium state after an hour of operation with radiant energy becoming the dominant mode of heat transfer.

[0042] The visual effect of the use of the inventive venting arrangement with a large fuel load of the type discussed below was that the wood smoke did not become overly dark or dense, but retained the light grey-blue color desired. The inventive venting
15 arrangement also reduced the amount of condensation of smoke and water vapor on the surface of the food during cooking.

[0043] In addition, the venting arrangement reduces the operating pressure within the cooking and smoking chamber **8** and therefore, in conjunction with the larger size and inventive design and structure of the smoke box **18** (discussed below), allows a much
20 larger load (up to as much as four cups or more) of wood chips, pellets or other pieces to be used in the smoke box **18**. Heretofore, in the prior single top vented electric smoker cabinets because of the build-up of pressure and unburned, flammable hydrocarbons caused by the partial combustion of, and the production of smoke from, the wood chips, the quantity of wood chips which could be used in the cabinet was only about 3/4 of a cup
25 or less.

[0044] Also, by providing lower air intake vents **24** and **28** and upper exhaust vents **34** and **36** on both sides of the cooking and smoking chamber **8** of the inventive apparatus **2**, the cooking and smoking chamber **8** is more evenly filled with smoke without any voids in the cooking and smoking zone. The inventive venting arrangement additionally
30 assists in directing the smoke upwardly through the food support racks **12**, thereby uniformly contacting and covering the food products with the desired amount of smoke.

[0045] The improved electrical heating element assembly **14** used in the inventive vertical electric cooker and smoker **2** preferably comprises: a holding tray **46** having a

reflective interior bottom surface **48**; one or more electric heating elements **50** positioned in the tray **46** above the reflective bottom surface **48**; a rear attachment bracket **52**; and a plurality of bottom legs **53**. The rear bracket **52** secures the heating element assembly **14** to the back wall **38** of the cooking and smoking chamber **8** and provides an air gap between the holding tray **46**, and smoke box **18**, and the back wall **38** of the chamber **8**.
5 The bottom legs **53** preferably space the holding tray **46** about 2.25 inches above the bottom **16** of the cooking and smoking chamber **8**. Also, a pair of spacers **54** and **57** project from the side of the holding tray **46** for spacing the holding tray **46** and smoke box **18** from the interior surface of the right side wall **32** of the vertical box **4** to provide an air
10 gap of about 0.40 inches.

[0046] As seen in FIGS. 2 and 3, the location of the smoke box **18** with respect to the heating element(s) **50** is established using novel and effective features to control the heating of the wood chips or other pieces contained in the box **18**. This includes a unique retaining station **55** provided on the holding tray **46** for receiving the bottom of the smoke
15 box **18** and holding the smoke box **18** above the electric heating element(s) **50**.

[0047] The retaining station **55** preferably comprises: (a) a cover plate **56** which at least partially covers the electric heating element(s) **50** and acts as a bottom plate for the retaining station **55**; (b) a plurality of spacers (stand-offs) **58** projecting from the upper surface of the cover plate **56** to create an air gap **60** between the surface of the cover plate
20 **56** and the bottom surface of the smoke box **18**; (c) a receiving slot structure **65**, including two short vertical side walls **62** and **64**, a short vertical back wall **66**, and an open front end **68**, for receiving and aligning the bottom of the smoke box **18** on top of the cover plate **56**; and (d) a reflector plate **70** extending rearwardly from the top of the short back wall **66** of the smoke box receiving slot structure **65** for shielding the back of the smoke
25 box **18** from radiant energy emitted or reflect by the heating element(s) **50** and/or the reflecting surface **48**.

[0048] The height of the stand offs **58** is preferable at least 0.12 inches but not more than 0.25 inches above the cover plate **56**. The height of the stand offs **58** is more preferably in the range of from about 0.10 inches to about 0.14 inches. By way of
30 example, but not by way of limitation, the cover plate **56** is preferably formed of aluminized steel, low carbon steel, stainless steel, porcelain coated de-carb steel, cast iron

or cast aluminum and the stand offs **58** are preferably formed of aluminized steel, low carbon steel, stainless steel, porcelain coated de-carb steel, cast iron or cast aluminum.

[0049] As an alternative to the use of the stand offs **58**, washers, screw assemblies, extruded holes, square extrusions, a plurality of elongated stand offs in receiving slot structure **65** or in the bottom of the smoke box **18**, for example, could instead be used to create or provide a space between the cover plate **56** and the bottom of the smoke box **18**.

[0050] In the inventive vertical electric cooking and smoking apparatus **2**, the cover plate **56** which acts as shield above the heating elements **50**, the spacers (stand-offs) **58** which raise the bottom of the smoke box **18** off of the cover plate **56**, the spacers **54** and **57** which provide an air gap between the side of the smoke box **18** and the interior side wall of the cooking and smoking chamber **8**, and the rear reflector **70** which shields the back of the smoke box **18**, operate together to (a) reduce the temperature and heat transfer at the bottom of the smoke box **18** sufficiently to increase the smoke time, (b) provide even heating at the bottom of the smoke box **18** so that the entire lower layer of wood chips inside the box **18** will start at the same time, and (c) eliminate hot pockets within the smoke box **18**.

[0051] The embodiment **18** of the inventive smoke generating box used in the vertical electric cooking and smoking apparatus **2** is illustrated in FIGS. 3-6. The inventive smoke box **18** comprises: a rectangular box **75** having a longitudinal axis **76**; a front handle **78**; a cooling plate or "false bottom" **80** which fits inside of the rectangular box **75**; and a removable lid assembly **82**. The false bottom **80** has a pair of downwardly extending side spacer rails **84** and **86** which support and space the false bottom **80** above the bottom **81** of the box **75** to provide an air gap **88** of from about 0.20 inches to about 0.50 inches, more preferably from about 0.33 inches to about 0.38 inches, between the false bottom **80** and the actual bottom **81** of the box **75**. This additional air gap **88** within the bottom of the box **75** operates to further stabilize the heating of the wood chips or other wood pieces in the smoke box **18**.

[0052] The rectangular box **75** will preferably be sized to contain at least four cups of wood chips or other pieces above the false bottom **80**. The interior of the rectangular box **75** will preferably have (a) a longitudinal length in the range of from about 6.0 inches to about 6.25 inches, (b) a width in the range of from about 4.25 inches to about 4.40 inches, and (c) a height in the range of from about 3.0 inches to about 3.25 inches.

[0053] The lid assembly **82** of the inventive smoke generating box **18** comprises: (a) a lower lid piece **90** having a lateral row of smoke openings **92** which extend through the lower lid piece **90** adjacent to the forward end **94** of the lid assembly **82**; (b) an upper lid piece **96** having a lateral row of smoke openings **98** which extend through the upper lid piece **96** adjacent to the forward end **94** of the lid assembly **82**; (c) a middle lid piece **100** positioned between the upper lid piece **96** and the lower lid piece **90** and having a lateral row of smoke openings **102** which extend through the middle lid piece **100** adjacent to the rearward end **104** of the lid assembly **82**; (d) a lower horizontal flow gap **106** formed between the lower and middle lid pieces **90** and **100**; (e) an upper horizontal flow gap **108** formed between the middle and upper lid pieces **100** and **96**; (f) a lower flow rail piece **110** extending laterally in the lower flow gap **106**; and (g) an upper flow rail piece **112** extending laterally in the upper flow gap **108**.

[0054] Each of the laterally extending lower and upper flow rail pieces **110** and **112** comprises a pair of parallel pass-through rails **110a** and **110b** and **112a** and **112b** which extend laterally across and block the upper and lower horizontal flow gaps **106** and **108**. The upstream rail **110a**, **112a** of each rail piece **110**, **112** has a series of smoke inlet holes **114**, **116** provided therethrough. The downstream rail **110b**, **112b** of each rail piece **110**, **112** has a series of smoke outlet holes **118**, **120** provided therethrough. Preferably, the smoke outlet holes **118**, **120** of each rail piece **110**, **112** are not in alignment with the smoke inlet holes **114**, **116** of the rail piece **110**, **112**. As a result, smoke flowing into an inlet hole **114**, **116** cannot flow directly (i.e., in a straight line) through an outlet hole **118**, **120** but instead is forced to change direction at least to some degree within the rail piece **110**, **112**.

[0055] The lower rail piece **110** is preferable positioned in the lower flow gap **106** at from about 1/3 to about 4/5, more preferably from about 1/2 to about 3/4, of the distance from the inlet end **122** to the outlet end **124** of the lower flow gap **106**. Similarly, the upper rail piece **112** is preferable positioned in the upper flow gap **108** at from about 1/3 to about 4/5, more preferably from about 1/2 to about 3/4, of the distance from the inlet end **126** to the outlet end **128** of the upper flow gap **108**.

[0056] For each of the lower, upper, and middle lid pieces **90**, **96**, **100**, the total proportional flow area of the respective row **92**, **98**, or **102** of smoke openings provided therethrough will preferably be, in the range of from about 0.9 to about 2.6 inches², more

preferably from about 1.3 to about 1.6 inches², per 80 in³ of volume of the cooking and smoke box **18**.

[0057] The lower and upper flow gaps **106** and **108** formed between the lid pieces will preferably each have a height which is in the range of from about 0.10 to about 0.17
5 inches, more preferably from about 0.12 to about 0.15 inches.

[0058] The total proportional flow area of the smoke inlet or outlet holes **114**, **116**, **118**, or **120** provided through each individual upstream and downstream rail **110a**, **110b**, **112a**, or **112b** of the rail pieces **110** and **112** will preferably be in the range of from about 0.25 to about 1.0 inches², more preferably from about 0.44 to about 0.62 inches², per 80
10 in³ of volume of the cooking and smoke box **18**. For each of the rail pieces **110** and **112**, the distance between the upstream rail **110a**, **112a** and the downstream rail **110b**, **112b** thereof will preferably be in the range of from about 0.25 to about 0.50 inches, more preferably from about 0.36 to about 0.40 inches.

[0059] In the inventive smoke box **18**, the smoke generated by heating the wood
15 pieces in the box **75** is forced to flow along a defined circuitous flow path **130** in which the smoke travels into the smoke openings **92** of the lower lid piece **90**, through a first portion of the lower horizontal flow gap **106** to the lower rail piece **110**, through the offset holes **110a** and **110b** of the lower rail piece, from the lower rail piece **110** to the smoke openings **102** of the middle lid piece **100**, through a first portion of the upper horizontal
20 flow gap **108** to the upper rail piece **112**, through the offset holes **112a** and **112b** of the upper rail piece **112**, from the upper rail piece **112** to the smoke openings **98** of the upper lid piece **96**, and out of the smoke openings **98** into the cooking and smoking chamber **8** of the inventive vertical electric apparatus **2**.

[0060] This circuitous path **130** acts as a flame suppression mechanism to prevent
25 and contain any fire in the smoke box and additionally provides for cooling and mixing of the smoke produced in the inventive smoke box **18** so that the smoke exhausted from the lid outlet openings **98** has a relatively uniform temperature and smoke concentration. The length of the circuitous path **130** also allows for the smoke temperature to be hot enough to maintain suspension of the smoke particles in the atmosphere but cool enough
30 to stay well below any ignition point when it exits from the smoke box **18**.

[0061] An alternative embodiment **150** of the inventive smoke box is illustrated in FIGS. 7 and 8. The inventive smoke box **150** is substantially the same as the inventive smoke box **18** except that rather than providing the circuitous exit path for the smoke through the lid of the box, a substantially similar flow path **152** is provided in one, two, 5 three, or all four of the vertical sides **154, 156, 158, 160** of the inventive smoke box **150**.

[0062] In the inventive smoke box **150**, each of the one or more vertical sides having a circuitous smoke exit path **152** provided therein comprises: (a) an inner vertical wall **162** having a row of smoke openings **164** which extend across the upper end portion thereof; (b) an outer vertical wall **166** having an open upper end **168**; (c) a middle vertical 10 wall **170** positioned between the inner and outer vertical walls **162** and **166**, and having a row of smoke openings **175** which extend across the bottom portion thereof; (d) an inner vertical flow gap **172** formed between the inner and middle vertical walls **162** and **170**; (e) an outer vertical flow gap **174** formed between the middle and outer vertical walls **170** and **166**; (f) an inner flow rail piece **176** extending horizontally in the inner flow gap **172**; 15 (g) an outer flow rail piece **178** extending horizontally in the outer vertical flow gap **174**; and (h) a row of smoke exhaust openings **180** formed through the top of the lid **182** of the box along the edge of the lid **182** for placement over the open upper end **168** of the outer vertical wall **166**.

[0063] Consequently, in the circuitous flow path **152** defined in the inventive smoke 20 box **150**, the smoke is forced to flow into the smoke openings **164** at the upper end of the inner vertical wall **162**, downwardly through the inner flow gap **172** to the inner rail piece **176**, from the inner rail piece **176** to the flow openings at the bottom of the middle vertical wall **170**, upwardly through the outer vertical flow gap **174** to the outer rail piece **178**, and from the outer rail piece **178** to and out of the smoke exhaust openings **180** of 25 the lid **182**. Alternatively, the smoke could exit through side exhaust openings provided at the upper end of the outer wall **166** rather than through the lid **182**.

[0064] The flow opening areas of the walls and lid, the rail piece flow opening areas, and the flow gap widths for the circuitous flow path **152** of the inventive smoke box **150** will preferably be the same as those of the flow path **130** provided in the lid assembly of 30 the inventive smoke box **18**.

* * * * *

[0065] Thus, the present invention is well adapted to carry out the objectives and attain the ends and advantages mentioned above as well as those inherent therein. While presently preferred embodiments have been described for purposes of this disclosure, numerous changes and modifications will be apparent to those of ordinary skill in the art. Such changes and modifications are encompassed within the invention.

CLAIMS

1. An apparatus for cooking and smoking food comprising:
 - a vertically extending cooking and smoking chamber having a left side wall, a right side wall, a back wall, a front opening, and a bottom floor;
 - 5 a door positionable on the front opening for closing and opening the front opening;
 - one or more air intake vents provided in a lower portion of the cooking and smoking chamber;
 - one or more exhaust vents provided in an upper portion of the cooking and smoking chamber; and
 - 10 one or more electric heating elements positioned in the lower portion of the cooking and smoking chamber, the one or more electric heating elements being spaced above the bottom floor of the cooking and smoking chamber.
- 15 2. The apparatus of claim 1 comprising two of the air intake vents and two of the exhaust vents wherein a first of the air intake vents is provide through a lower portion of the right side wall, a second of the air intake vents is provide through a lower portion of the left side wall, a first of the exhaust vents is provided through an upper portion of the right side wall, and a second of the exhaust vents is provided through an upper portion of
20 the left side wall.
3. The apparatus of claim 2 wherein the first and the second air intake vents are located at an elevation which is at or below an elevation of the electric heating element.
4. The apparatus of claim 2 wherein:
 - the first air intake vent comprises one or a series of openings extending
25 horizontally across at least 30% of a horizontal width of the right side wall and
 - the second air intake vent comprises one or a series of openings extending horizontally across at least 30% of a horizontal width of the left side wall.
- 30 5. The apparatus of claim 2 wherein the first and the second air intake vents each have an open flow area in a range of from 1.0 to 4.0 inches² per each 2.94 ft³ of volume of the cooking and smoking chamber.

6. The apparatus of claim 5 wherein the first and the second exhaust vents each have a flow area in a range of from 4.0 to 9.0 inches² per each 2.94 ft³ of volume of the cooking and smoking chamber.

7. The apparatus of claim 6 wherein the first and the second exhaust vents each have
5 a louvered cover.

8. The apparatus of claim 2 wherein:

the cooking and smoking chamber has an uppermost food support rack
positioned therein and

10 the first and the second exhaust vents are positioned at an elevation above an
elevation of the uppermost food support rack.

9. The apparatus of claim 1 further comprising:

a smoke box for generating smoke; and

15 a smoke box placement station in the cooking and smoking chamber for
placement of the smoke box at least partially over the one or more
electric heating elements.

10. The apparatus of claim 9 wherein:

the apparatus further comprises an element tray in which the one or more
electric heating elements are positioned, the element tray being spaced
above the bottom floor of the cooking and smoking chamber and

20 the smoke box placement station comprises

a cover plate on the element tray which at least partially covers the one
or more electric heating elements and

25 a plurality of spacing elements on an upper surface of the cover plate
on which the smoke box is placeable to provide an air gap
between a bottom of the smoke box and the cover plate.

11. The apparatus of claim 10 wherein the element tray has a reflective upper surface
positioned beneath the one or more electric heating elements.

12. The apparatus of claim 10 further comprising:

30 an air gap between the element tray and the back wall of the cooking and
smoking chamber and

a horizontal reflector plate extending rearwardly from the element tray toward
the back wall of the cooking and smoking chamber which shields a
vertical back side of the smoke box from radiant energy which is

emitted from the one or more electric heating elements, reflected from the reflective upper surface of the element tray, or both.

13. The apparatus of claim 9 wherein the smoke box comprises:

a container having an actual bottom and an interior and

5 a false bottom in the interior of the container spaced above the actual bottom of the container such that a bottom air space is defined between the false bottom and the actual bottom of the container.

14. The apparatus of claim 9 wherein the smoke box comprises:

10 an interior combustion area for combusting wood chips or other pieces in an oxygen deficient environment to produce smoke and

an exhaust flow assembly which defines a circuitous exhaust flow path for the smoke wherein the smoke must flow in a first direction through an inner flow gap formed by the exhaust flow assembly and then must
15 flow in a second direction, different from the first direction, through an outer flow gap formed by the exhaust flow assembly.

15. The apparatus of claim 14 wherein the exhaust flow assembly further comprises:

a first obstructing structure in the inner flow gap which at least momentarily alters the flow path of the smoke as the smoke travels from an inlet end
20 to an outlet end of the inner flow gap and

a second obstructing structure in the outer flow gap which at least momentarily alters the flow path of the smoke as the smoke travels from an inlet end to an outlet end of the outer flow gap.

16. The apparatus of claim 15 wherein the first and the second obstructing structures
25 each comprise an upstream rail and a parallel downstream rail, the upstream and the downstream rails each have a plurality of holes for flow of the smoke through the rails, and the holes of the downstream rail are not in alignment with the holes of the upstream rail.

17. The apparatus of claim 15 wherein the exhaust flow assembly is formed in a lid of
30 the smoke box.

18. The apparatus of claim 15 wherein the exhaust flow assembly is formed in a vertical side wall of the smoke box.

19. The apparatus of claim 15 wherein the exhaust flow assembly is formed in a plurality of vertical side walls of the smoke box.

20. A smoke box apparatus comprising:

5 a container having an interior combustion area for combusting wood chips or other pieces in an oxygen deficient environment to produce smoke and an exhaust flow assembly which defines a circuitous exhaust flow path for the smoke wherein the smoke must flow in a first direction through an inner flow gap formed by the exhaust flow assembly and then must flow in a second direction, different from the first direction, through an
10 outer flow gap formed by the exhaust flow assembly.

21. The smoke box apparatus of claim 20 wherein the container has an actual bottom and a false bottom is positioned in the container at the bottom of the interior combustion area, the false bottom being spaced above the actual bottom of the container such that a bottom air space is defined between the false bottom and the actual bottom of the
15 container.

22. The smoke box apparatus of claim 20 wherein the exhaust flow assembly further comprises:

20 a first obstructing structure in the inner flow gap which at least momentarily alters the flow path of the smoke as the smoke travels from an inlet end to an outlet end of the inner flow gap and a second obstructing structure in the outer flow gap which at least momentarily alters the flow path of the smoke as the smoke travels from an inlet end to an outlet end of the outer flow gap.

23. The smoke box apparatus of claim 22 wherein the first and the second obstructing
25 structures each comprise an upstream rail and a parallel downstream rail, the upstream and the downstream rails each have a plurality of holes for flow of the smoke through the rails, and the holes of the downstream rail are not in alignment with the holes of the upstream rail.

24. The smoke box apparatus of claim 22 wherein the exhaust flow assembly is
30 formed in a lid of the container.

25. The smoke box apparatus of claim 22 wherein the exhaust flow assembly is formed in a vertical side wall of the container.

26. The smoke box apparatus of claim 22 wherein the exhaust flow assembly is formed in a plurality of vertical side walls of the container.

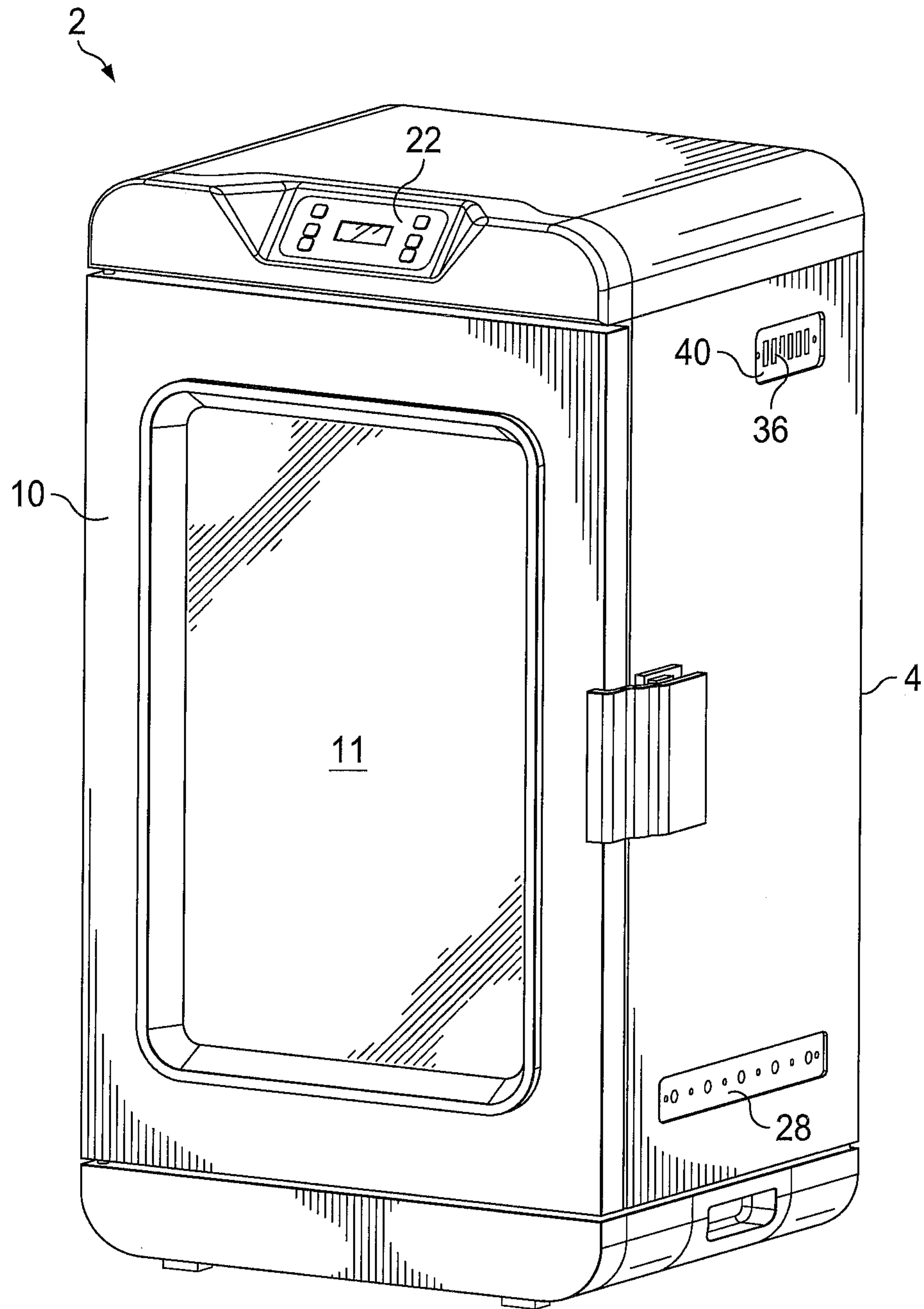

FIG. 1

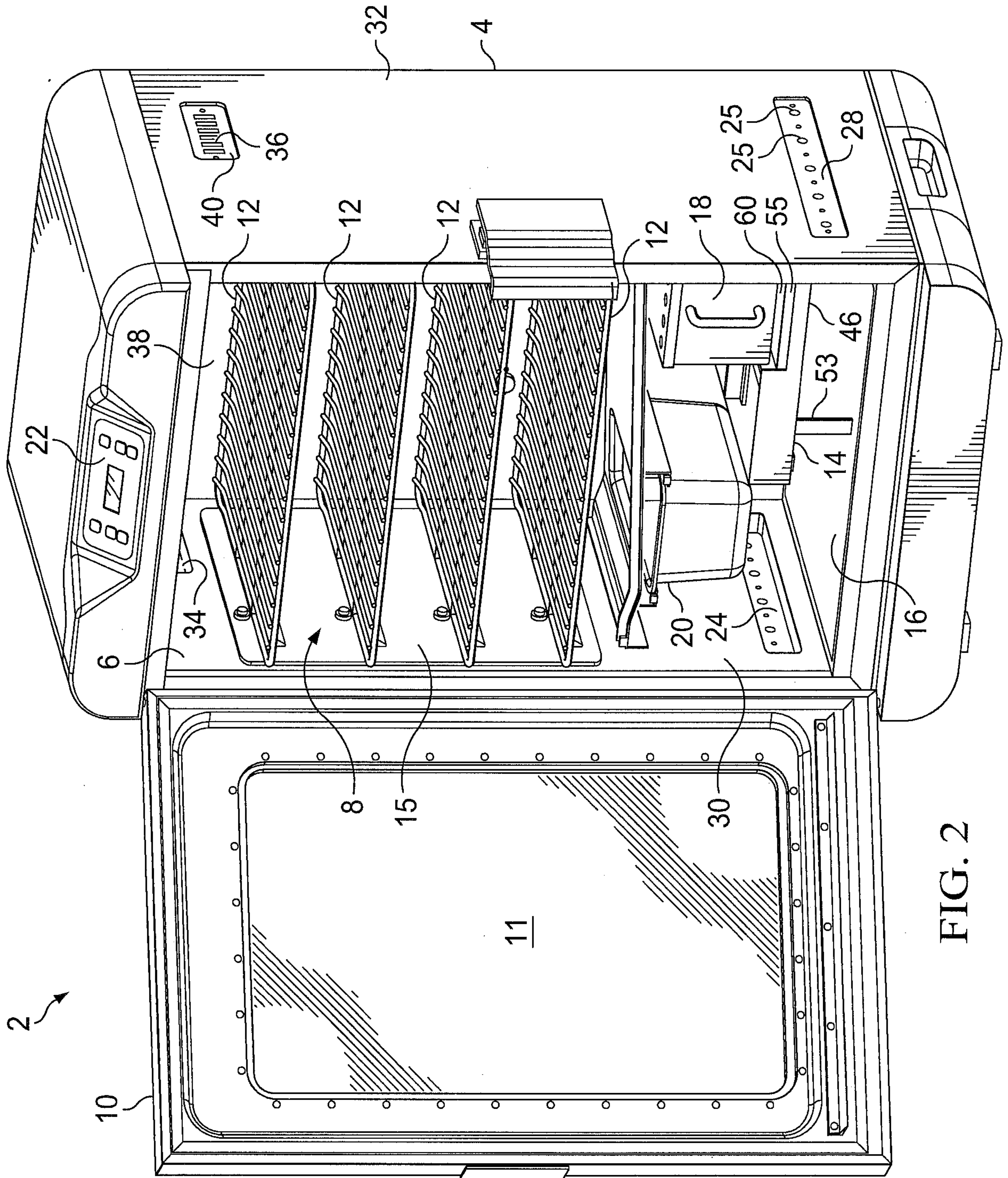

FIG. 2

3/7

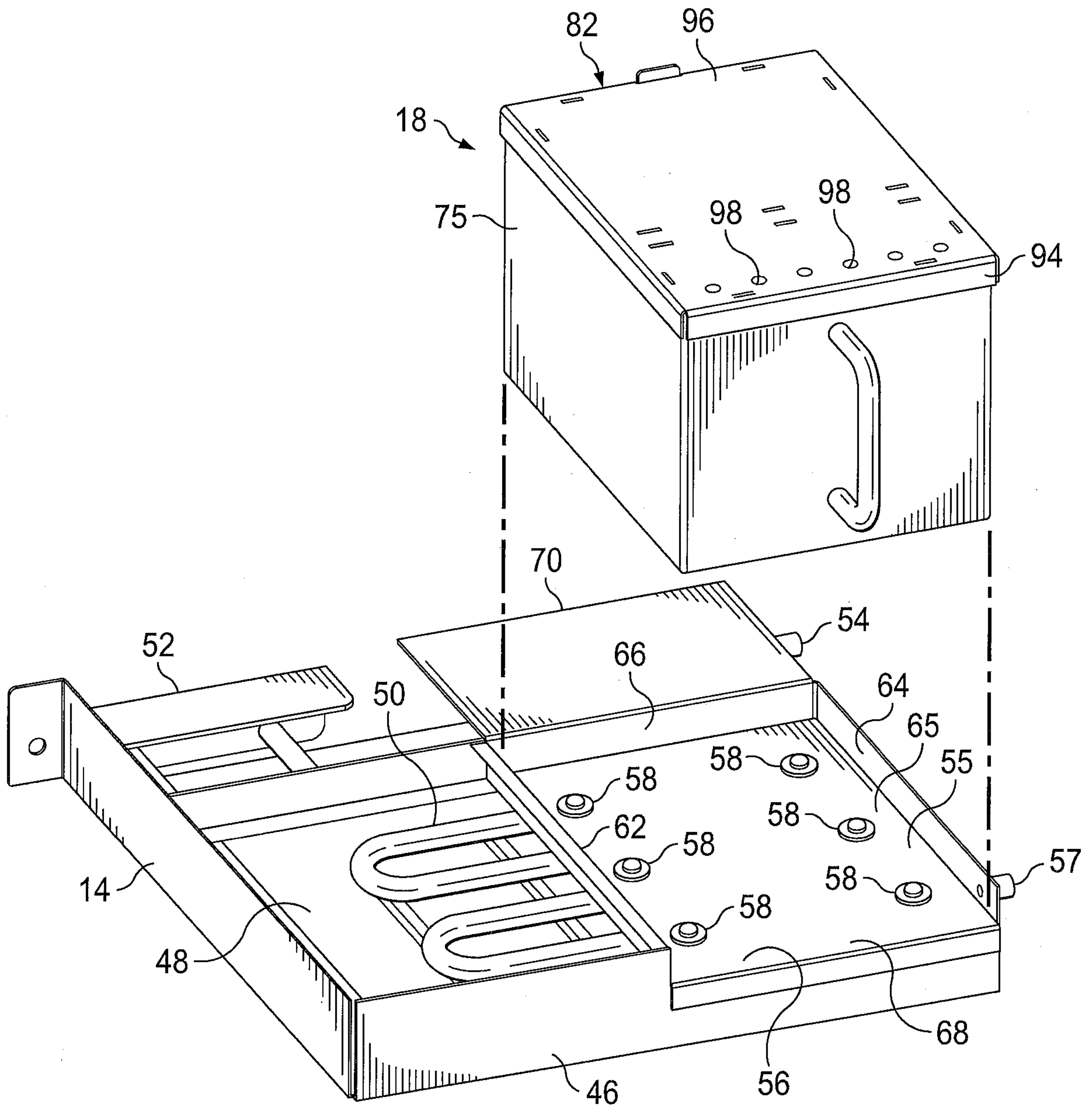

FIG. 3

110,112

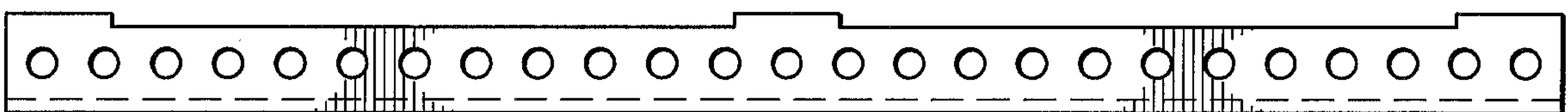

FIG. 5

4/7

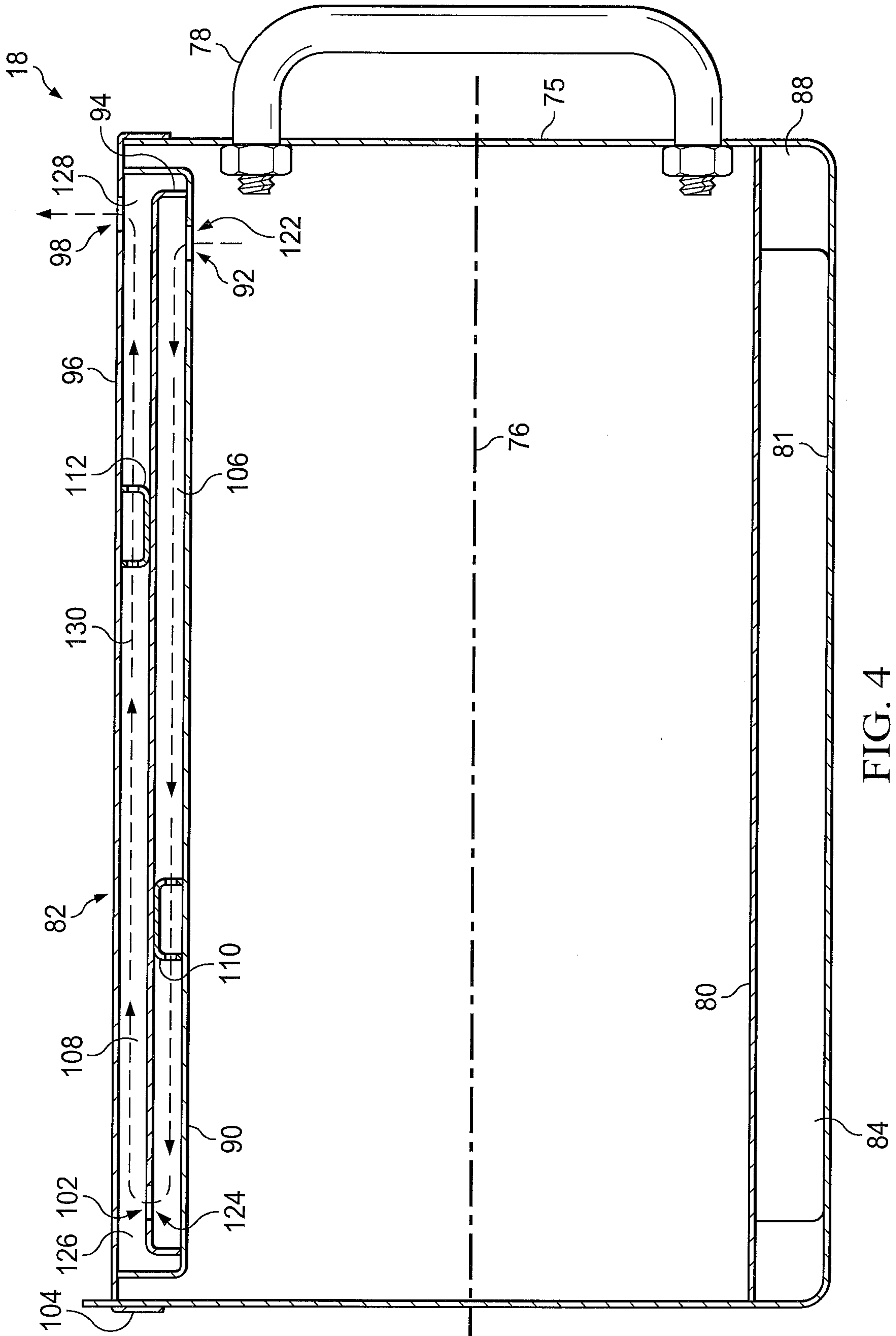

FIG. 4

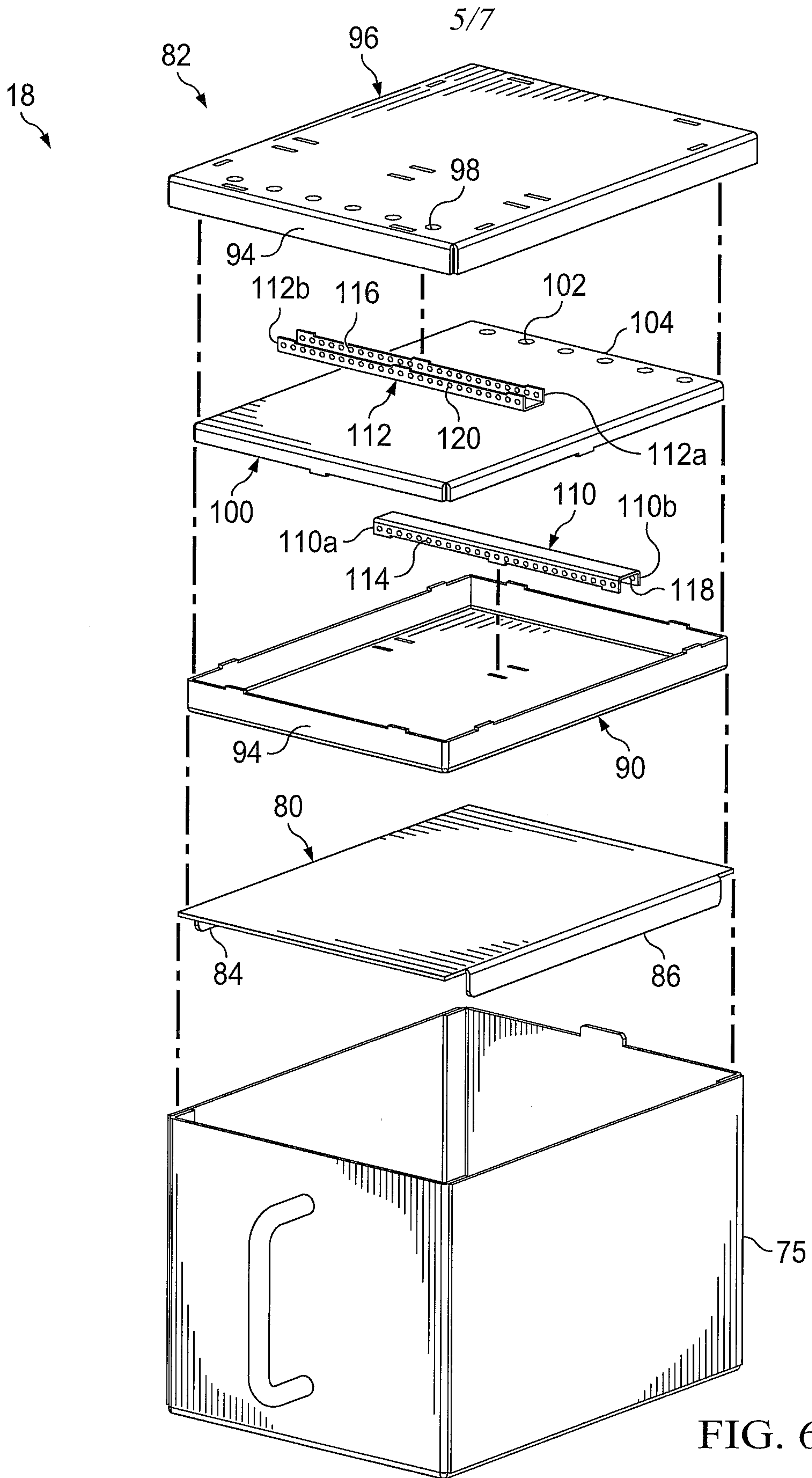

FIG. 6

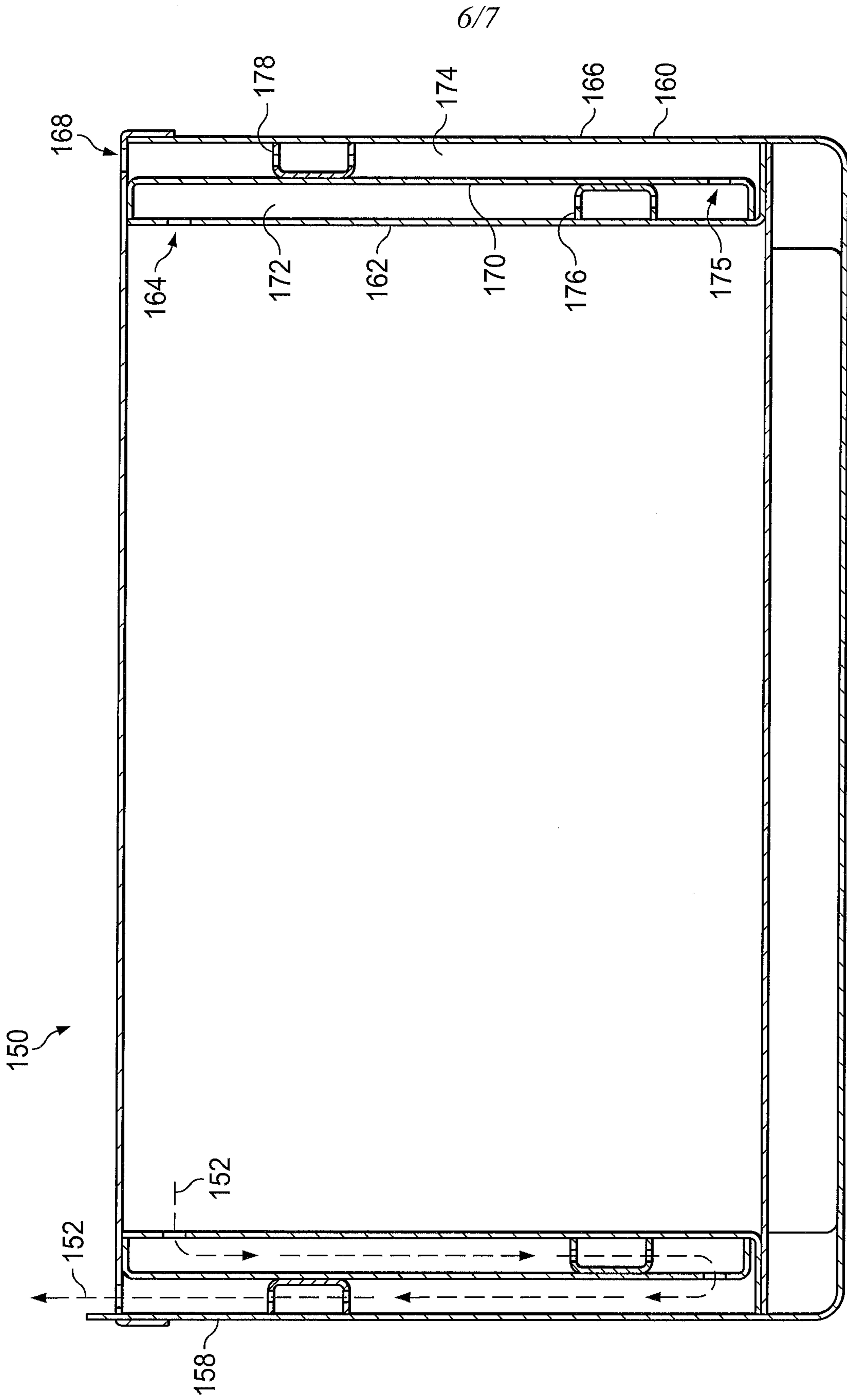

FIG. 7

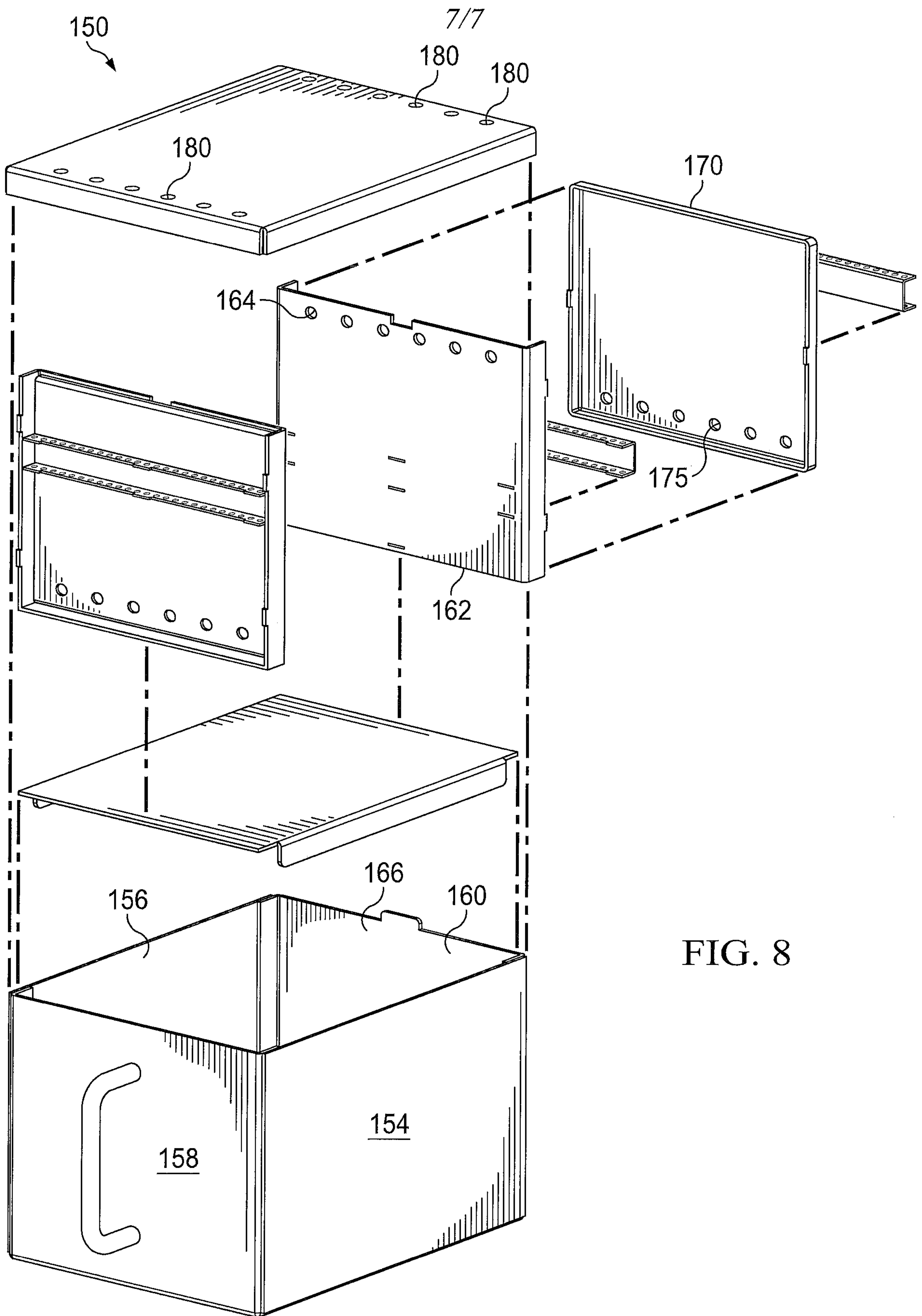

FIG. 8

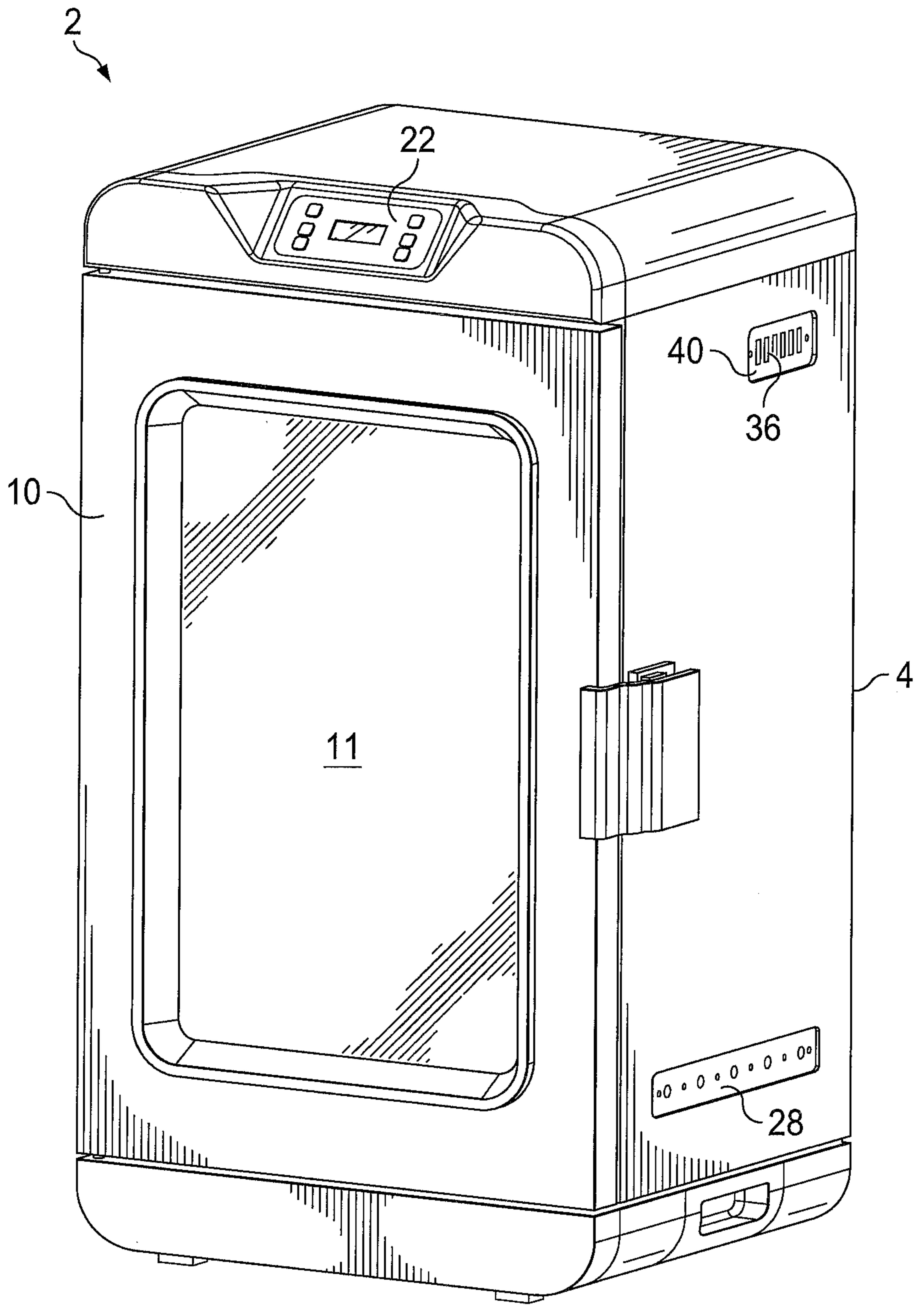

FIG. 1