

(21) Application No: 0621861.4  
(22) Date of Filing: 02.11.2006

(71) Applicant(s):  
**Kirnan Holdings Limited**  
(Incorporated in the United Kingdom)  
**Peterbridge House, The Lakes,**  
**NORTHAMPTON, Northamptonshire,**  
**NN4 7HB, United Kingdom**

(72) Inventor(s):  
**Nicholas Wilkins**

(74) Agent and/or Address for Service:  
**Barker Brettell**  
**10-12 Priests Bridge, LONDON, SW15 5JE,**  
**United Kingdom**

(51) INT CL:  
**A45D 19/00** (2006.01)

(56) Documents Cited:  
**WO 2003/011069 A1** **US 5287864 A**  
**US 5042514 A**

(58) Field of Search:  
UK CL (Edition X ) **A4V**  
INT CL **A45D**  
Other:

(54) Abstract Title: **Sheet for a hairdresser to mask selected strands of hair**

(57) A device allowing a hairdresser to mask selected strands of hair belonging to a subject whilst treating other selected strands of the subject's hair are treated comprises a sheet of flexible substrate 24 with an adhesive portion allowing it to be removably attached to the subjects hair, characterised in that it is adapted to removably engage with a tool such that the device may be manipulated with the tool. A kit may be provided comprising of a pack of such sheets and a tool.

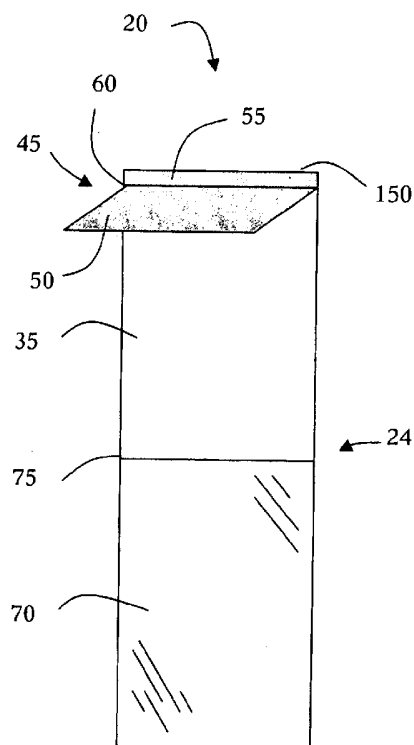

Figure 5

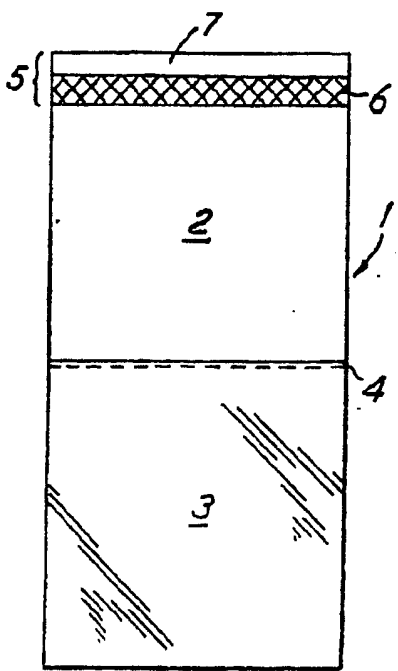

FIG. 1

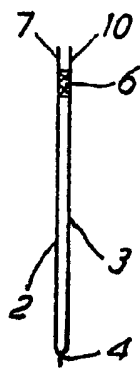

FIG. 2

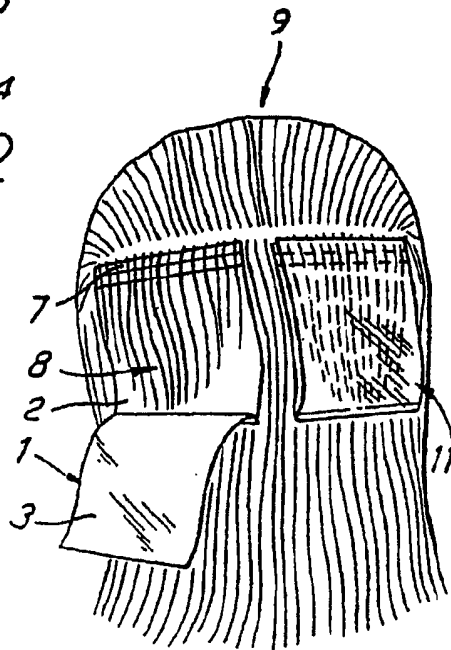

FIG. 3

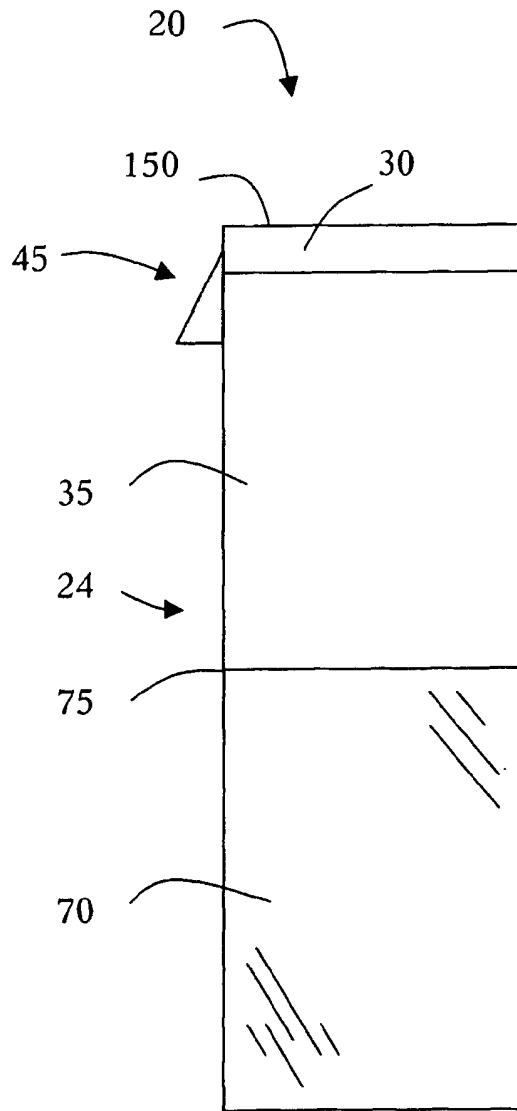

Figure 4

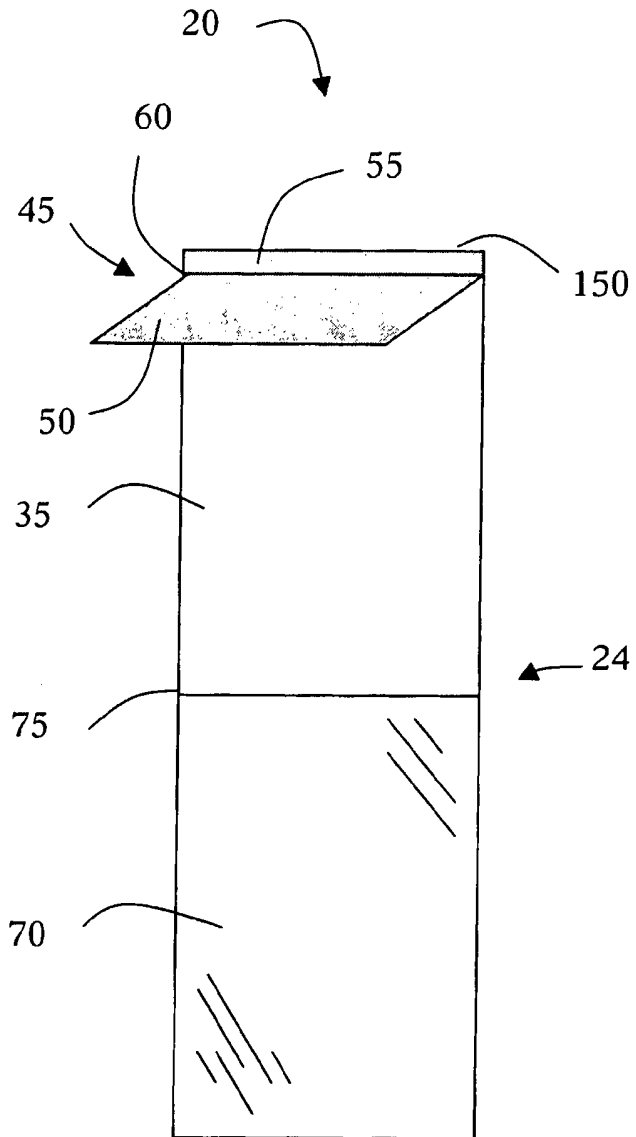

Figure 5

4/6

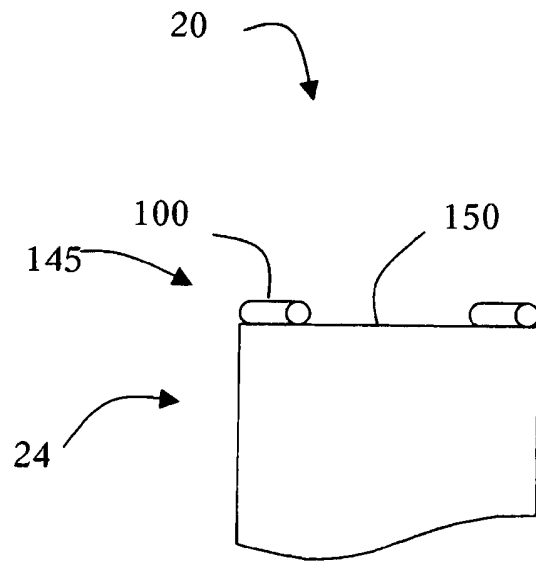

Figure 6A

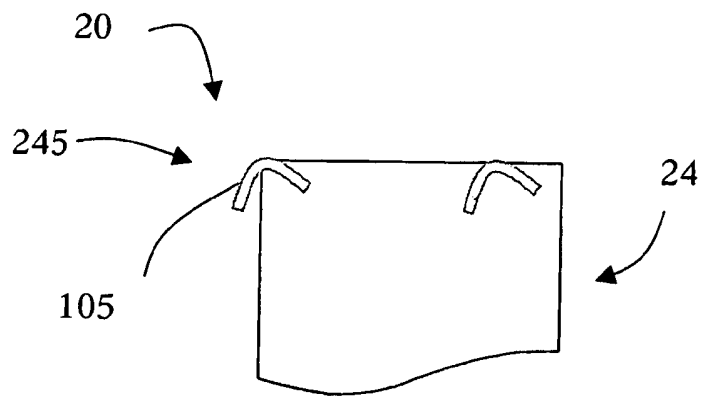

Figure 6B

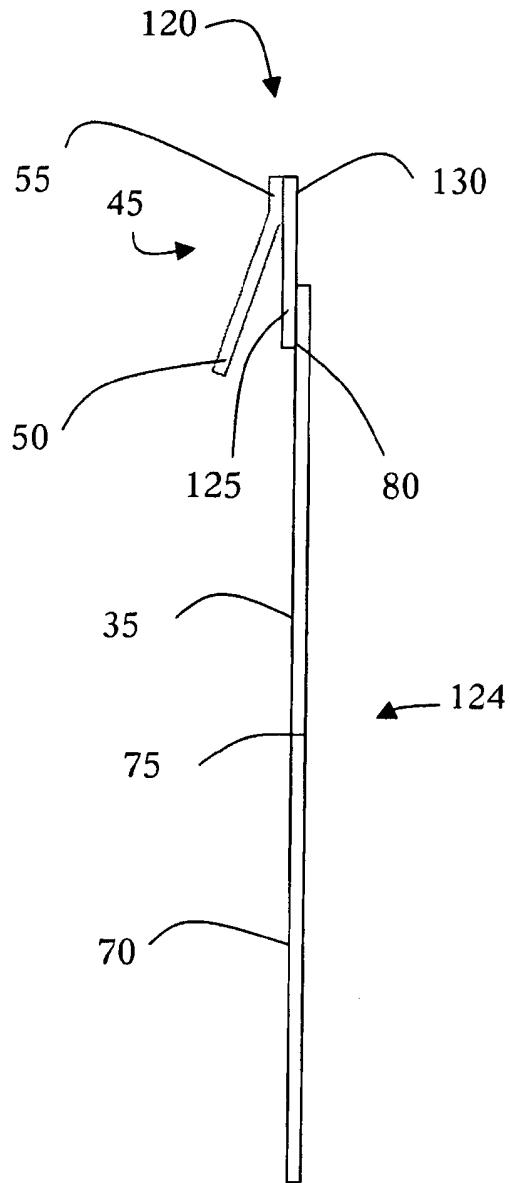

Figure 7

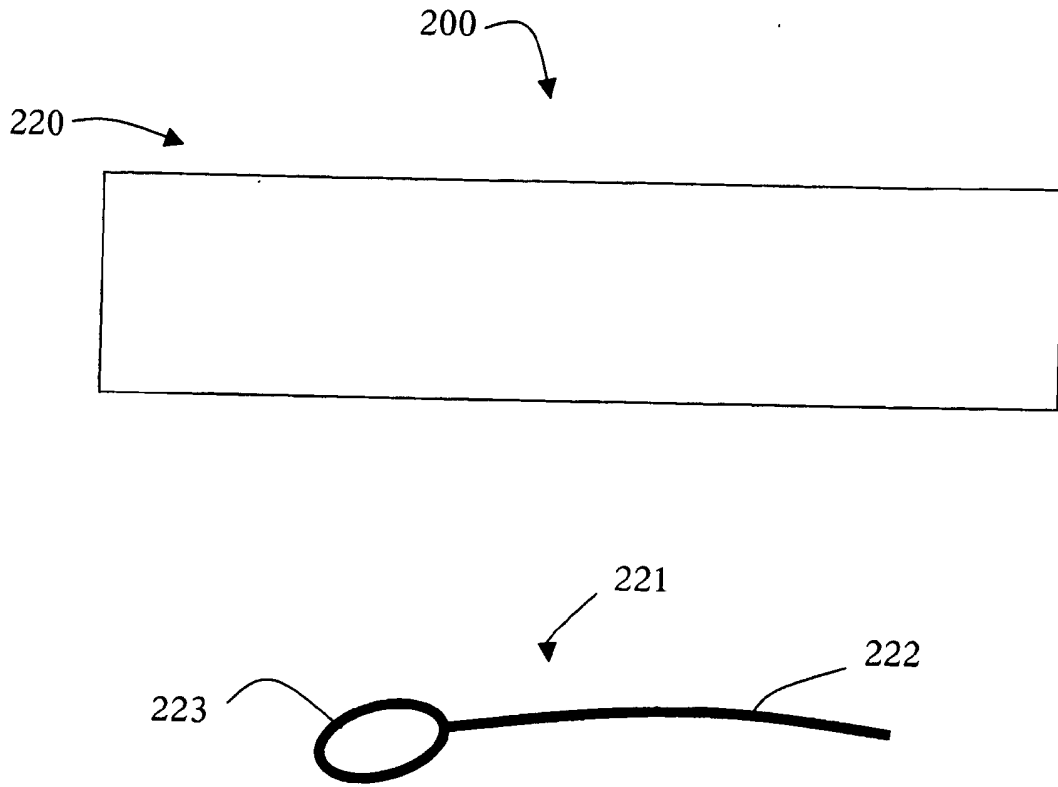

Figure 8

**IMPROVED MASKING SHEET**

[001] This invention relates to a hairdresser's masking sheet and a kit containing the sheet. In particular, this invention relates to a hairdresser's masking sheet having means for assisting a hairdresser position the sheet adjacent to strands of hair to be treated.

[002] Masking sheets are generally known in the hairdressing art. For example, GB 2140682 discloses a masking sheet. The prior art masking sheet is illustrated in Figures 1 to 3 of the accompanying drawings.

[003] Here there is shown a rectangular elongate sheet 1 comprising a rectangular panel 2 of white substantially opaque plastics material and a rectangular panel 3 of substantially transparent plastics material. The panels 2 and 3 are of substantially equal area and are welded one to another along a common edge, or co-extruded, to form a transversely extending hinge 4. An upper transverse marginal edge portion 5 of the panel 2 is joined to an adhesive tape 6 having pressure sensitive contact adhesive applied to a surface thereof, which tape has a margin 7 free of adhesive.

[004] In use, strands of a head of hair are selected by a technique known as "weaving" and the panel 2 is placed under selected strands of hair, as shown at 8 in Figure 3, of a head of hair 9 such that the margin 7 is located adjacent the scalp of the head 9. The adhesive tape 6 adheres to the selected strands of hair 8 adjacent the scalp such that the sheet 1 is located under and relative to the selected strands of hair 8.

[005] The selected strands of hair 8 subsequently are coated with a liquid colouring substance (not shown) and the panel 3 is folded about the hinge 4 and is superimposed on the panel 2 with the selected strands of hair 8 located there between, a transverse marginal edge portion of the panel 3 adhering to the marginal edge portion 5 of the panel 2 by means of the



adhesive tape 6 such that a margin 10 of the panel 3 is located adjacent the margin 7.

[006] In this manner, the selected strands of hair 8 are located within an envelope defined by the panels 2 and 3, the hinge 4 and the adhesive tape 5 6, as shown at 11 in Figure 3, and are thus isolated from adjacent strands of hair while colouration of the selected strands of hair is completed.

[007] This method involves the step of placing panel 2 under selected strands of hair 8. A hairdresser will do this by lifting the selected strands of hair 8 with one hand, whilst using the other hand to place panel 2.

10 [008] In most circumstances, the hairdresser will want to position the margin 7 as closely as possible to the roots 12 of the selected strands of hair 8. It is also desirable that the sheet 1 be firmly resting against the scalp of the head 9 before the selected strands of hair 8 are placed on panel 2. This helps to ensure that a greater portion of the selected strands 15 of hair 8 can be encased and coated with the liquid colouring substance. It is not straightforward to do this with existing masking sheets.

[009] A way to ameliorate these problems has been sought.

[010] According to the invention there is provided a hairdresser's masking sheet of flexible material for masking selected strands of a head 20 of hair from other strands of the hair while the selected strands are treated wherein the sheet comprises a substrate of flexible material and an adhesive portion whereby application of the adhesive portion to a portion of the head of hair selectively and removably unites the sheet with the strands of the portion of hair thereby brought into contact therewith 25 characterised in that the sheet comprises a manipulation means for engagement with a tool such that the sheet may be manipulated by the tool.

[011] It has been found that the inclusion of a manipulation means on the masking sheet aids in overcoming the problems the hairdresser encounters when trying to position a masking sheet adjacent to the strands of hair selected for treatment and particularly to the roots of the strands of hair.

5 [012] In the prior art masking sheet, to position the masking sheet the hairdresser uses the fingers and thumb of their free hand to hold the sheet 1 in a position so that margin 7 firmly rests adjacent the hair roots 12 along the width of margin 7. In contrast, in the present invention the manipulation means enables the hairdresser to keep their free hand for  
10 holding the sheet in a position remote from the sheet so that their hand does not obstruct application of the strands of hair to the sheet. Also, because the free hand is remotely situated from the masking sheet, it is prevented from contacting and adhering to the adhesive portion of the sheet. Furthermore, the manipulation means may be used to position the  
15 sheet close to or at the roots of the selected strands of hair.

[013] According to the invention, there is also provided a hairdresser's masking kit comprising:

a masking sheet according to the invention; and

20 a tool comprising an elongate portion suitable for use with the manipulation means.

[014] In some aspects, the tool may be a rigid wire. The tool may also have a handle. The rigid wire may be curved such that, in use, the tool fits against the curve of a person's head. The tool may also be a styling comb used by a hairdresser with an elongate tail. In this way, when using  
25 the masking sheet the hairdresser can readily alternate between collecting the strands of hair to be treated using the toothed portion of a comb followed by using the tail of the comb to support the masking sheet.

[015] According to some aspects of the invention, the manipulation means is in the form of a flap, one or more tubes and/or a plurality of hooks. Where the masking sheet of the invention is used with a tool, the elongate portion of the tool may be inserted underneath the flap or hooks  
5 or through the tube(s) so that the masking sheet can be positioned adjacent the roots of selected strands of hair to be treated.

[016] The masking sheet generally has a front side on which the selected strands of hair are placed and a rear side which faces the head of hair. According to some aspects of the invention, the manipulation means is  
10 attached to the rear side of the sheet.

[017] According to some aspects of the invention, the manipulation means is formed from a material of greater stiffness than the substrate of flexible material. Particularly where the flexible material is a plastics (e.g., polyethylene) film, the greater stiffness of the manipulation means  
15 helps to ensure that the manipulation means functions during use without collapsing under the weight of the masking sheet. The manipulation means may be formed from a waterproof and chemical-resistant wax- or plastics-coated paper. This provides a material with sufficient stiffness which remains unaffected by exposure to the colouring and/or bleaching  
20 agents commonly used by a hairdresser.

[018] According to some aspects of the invention, the substrate of flexible material comprises a back panel joined to a front panel. This permits easy folding of the front panel to overlap with the back panel so as to envelope the strands of hair being treated.

25 [019] According to some aspects of the invention, the adhesive used for the adhesive portion is water soluble or water dispersible. This can enable the hairdresser to easily release the treated strands of hair from the masking sheet when treatment is complete.

[020] According to some aspects of the invention, the masking sheet includes a stiffening panel at its proximal end to support the manipulation means. The stiffening panel prevents the sheet from crumpling laterally or longitudinally when manipulated by a tool. The adhesive portion may be provided on a front side of the stiffening panel and the manipulation means may be provided on a rear side of the stiffening panel. The stiffening panel may overlap with the flexible substrate such that the sheet is not hinged where the stiffening panel and flexible substrate are joined.

[021] The invention will now be illustrated by way of example without limiting the scope of the invention claimed with reference to the following Figures of the accompanying drawings in which:

**Figure 1** shows a plan view of a prior art sheet;

**Figure 2** shows a cross-section of the sheet shown in Figure 1 when in use;

**Figure 3** shows a diagrammatic representation of the sheet shown in Figure 1 when in use;

**Figure 4** shows a schematic perspective view of the front of a first embodiment of a sheet according to the invention;

**Figure 5** shows a schematic perspective view of the rear of the first embodiment;

**Figures 6A** shows a partial view of the rear of a first embodiment with alternative manipulation means in the form of tubes; and **Figure 6B** shows a partial view of the rear of a first embodiment with an alternative manipulation means in the form of hooks;

**Figure 7** shows a side-on cross-sectional view of a sheet according to a second embodiment of the invention; and

**Figure 8** shows a schematic view of a kit according to the present invention.

[022] Figure 4 shows a first embodiment of a masking sheet 20 according to the invention which comprises a manipulation means 45 for allowing  
5 the masking sheet 20 to be positioned by a tool (not shown) and an elongate substrate 24 which, in use, is used to envelope selected strands of hair (not shown) wherein the elongate substrate 24 has a proximal end 150 which, in use, is placed on a head of hair (not shown) at which end 150 the manipulation means 45 is provided.

10 [023] Elongate substrate 24 is formed from a flexible material. It has, starting from its proximal end 150, an adhesive portion 30 which is provided on a front side of the elongate substrate 24, an opaque supporting panel 35, and a substantially transparent enveloping panel 70 wherein supporting panel 35 is joined to enveloping panel 70 at join 75.  
15 In use, the enveloping panel 70 may be folded at join 75 over supporting panel 35 and adhered to adhesive portion 30 so as to envelope selected strands of hair (not shown).

[024] The adhesive portion 30 extends up to proximal end 150 such that there is no margin between the adhesive portion 30 and proximal end 150  
20 which is free from adhesive. This is useful because it enables the product to be attached to the roots of the hair. The adhesive used is water dispersible so that the masking sheet is removed when the head of hair is washed.

[025] Join 75 acts as a hinge to aid the folding of enveloping panel 70  
25 over supporting panel 35. Join 75 is formed by enveloping panel 70 being welded to supporting panel 35. Alternatively, join 75 is formed by welding supporting panel 35 to enveloping panel 70 or by co-extruding supporting panel 35 and enveloping panel 70.

[026] In Figure 5, manipulation means 45 is shown in the form of a flap provided on a rear side of elongate substrate 24 at proximal end 150. Manipulation means 45 is formed from a sheet of glassine paper. Starting from proximal end 150 of elongate substrate 24, manipulation means 45 has a transverse strip 55 by which the manipulation means 45 is mounted on the rear side of elongate substrate 24 and a flap 50 for engaging with a tool. Where flap 50 meets the transverse strip 55, the manipulation means 45 is folded such that a tool (not shown) can be inserted under flap 50. As an alternative to the embodiment shown in Figures 4 and 5, manipulation means 45 may be mounted on the rear of elongate substrate 24 such that it is spaced from proximal end 150. As a further alternative, the manipulation means is formed from an alternative waterproof and chemical-resistant wax- or plastics-coated paper such as a silicone-coated paper.

[027] In Figures 6A and 6B of the drawings, there are shown partial rear views of sheet 20 with alternative manipulation means 145, 245. Like features to the first embodiment shown in Figures 4 and 5 are denoted by like reference numerals. In Figure 6A, manipulation means 145 has a pair of cylindrical tubes 100 shaped to received an elongate tool (not shown) provided on each side of proximal end 150 of elongate substrate 24. Alternatively, the pair of cylindrical tubes 100 may be provided on a rear side of elongate substrate 24 at proximal end 150. In Figure 6B, manipulation means 245 has a pair of hooks 205 each provided close to a lateral edge of the rear side of elongate substrate 24 at proximal end 150.

[028] Figure 7 shows a sheet 120 according to a second embodiment of the invention which comprises a stiffening panel 125 on which is provided a manipulation means 45 for allowing the masking sheet 120 to be manipulated by a tool (not shown) and an elongate substrate 124 which, in use, is used to envelope selected strands of hair (not shown) wherein the stiffening panel 125 overlaps elongate substrate 124 where they are

joined. Like features of the second embodiment to the first are denoted by like reference numerals.

[029] Stiffening panel 125 has an adhesive portion 130 provided on its front side. Stiffening panel 125 is provided at a proximal end of sheet  
5 120 such that, in use, it is placed on a head of hair (not shown). Manipulation means 45 is provided on a rear side of the stiffening panel 125 at its proximal end. The distal end of stiffening panel 125 overlaps with elongate substrate 124.

[030] Elongate substrate 124 is formed from a flexible material. It has  
10 an opaque supporting panel 35, and a substantially transparent enveloping panel 70 wherein supporting panel 35 is joined to enveloping panel 70 at join 75. In use, the enveloping panel 70 may be folded at join 75 over supporting panel 35 and adhered to adhesive portion 130 so as to envelope selected strands of hair (not shown). Thus enveloping panel 70 has a  
15 greater length than supporting panel 35.

[031] Figure 8 shows a kit 200 according to the invention which comprises a pack 220 of 10 sheets (not shown) according to the invention and a tool 221. Tool 221 has a rod 222 joined to a tool handle 223 for a hairdresser to hold so as to control tool 221 in order to support a sheet  
20 20,120 in use. Rod 222 is curved such that, in use, tool 221 fits against the curve of a person's head (not shown). As an alternative to the kit 200 shown in Figure 8, the number of sheets according to the invention included in the kit may be changed to any number of sheets from 1 to 1000, for example. As a further alternative, the kit 200 may include a  
25 plurality of tools 221, for example from 2 to 5.

## CLAIMS

1. A hairdresser's masking sheet of flexible material for masking selected strands of a head of hair from other strands of the hair while the selected strands are treated wherein the sheet comprises a substrate of flexible material and an adhesive portion whereby application of the adhesive portion to a portion of the head of hair selectively and removably unites the sheet with the strands of the portion of hair thereby brought into contact therewith characterised in that the sheet comprises a manipulation means for engagement with a tool such that the sheet may be manipulated by the tool.
2. The sheet as defined in claim 1, wherein the manipulation means is adapted for receiving a tool comprising an elongate portion.
3. The sheet as defined in claim 2, wherein the elongate portion comprises the tail of a styling comb.
4. The sheet as defined in any one of the preceding claims which comprises a stiffening panel to support the manipulation means.
5. The sheet as defined in claim 4 wherein the adhesive portion is provided on the stiffening panel.
6. The sheet as defined in claim 4 or claim 5 wherein the stiffening panel overlaps the flexible substrate.
7. The sheet as defined in any one of the preceding claims, wherein the manipulation means is formed from a material of greater stiffness than the substrate of flexible material.
8. The sheet as defined in any one of the preceding claims, wherein the manipulation means is formed from a wax- or plastics-coated paper, preferably glassine paper.



9. The sheet as defined in any one of the preceding claims, wherein the manipulation means comprises a flap, a tube or a plurality of hooks.
10. A hairdresser's masking sheet substantially as hereinbefore described with reference to one or more of Figures 4 to 7 of the  
5 accompanying drawings.
11. A hairdresser's masking kit comprising:
- a masking sheet according to any one of the preceding claims; and
  - a tool comprising an elongate portion suitable for use with the manipulation means when treating selected strands of a head of hair.
- 10 12. A kit substantially as hereinbefore described with reference to Figure 8 of the accompanying drawings.

**Application No:** GB0621861.4

**Examiner:** Mr Mike Leaning

**Claims searched:** 1-12

**Date of search:** 17 January 2007

## Patents Act 1977: Search Report under Section 17

### Documents considered to be relevant:

Category	Relevant to claims	Identity of document and passage or figure of particular relevance
X	1-4,6,9&11	US5287864 A (GALLO) Please see the figures and the description, especially column 5 lines 5-12.
A	-	WO03/011069 A1 (DE BENEDICTIS) Please see figures 12-18 and the third paragraph on page 15.
A	-	US5042514 A (BASTIEN) Please see the figures and column 5 line 36 to column 6 line 2.

### Categories:

X	Document indicating lack of novelty or inventive step	A	Document indicating technological background and/or state of the art.
Y	Document indicating lack of inventive step if combined with one or more other documents of same category.	P	Document published on or after the declared priority date but before the filing date of this invention.
&	Member of the same patent family	E	Patent document published on or after, but with priority date earlier than, the filing date of this application.

### Field of Search:

Search of GB, EP, WO & US patent documents classified in the following areas of the UKC<sup>X</sup> :

A4V

Worldwide search of patent documents classified in the following areas of the IPC

A45D

The following online and other databases have been used in the preparation of this search report

Online: WPI, EPODOC.