

A. HARLEY.
BLIND SLAT HOLDER AND FASTENER.

No. 522,593.

Patented July 10, 1894.

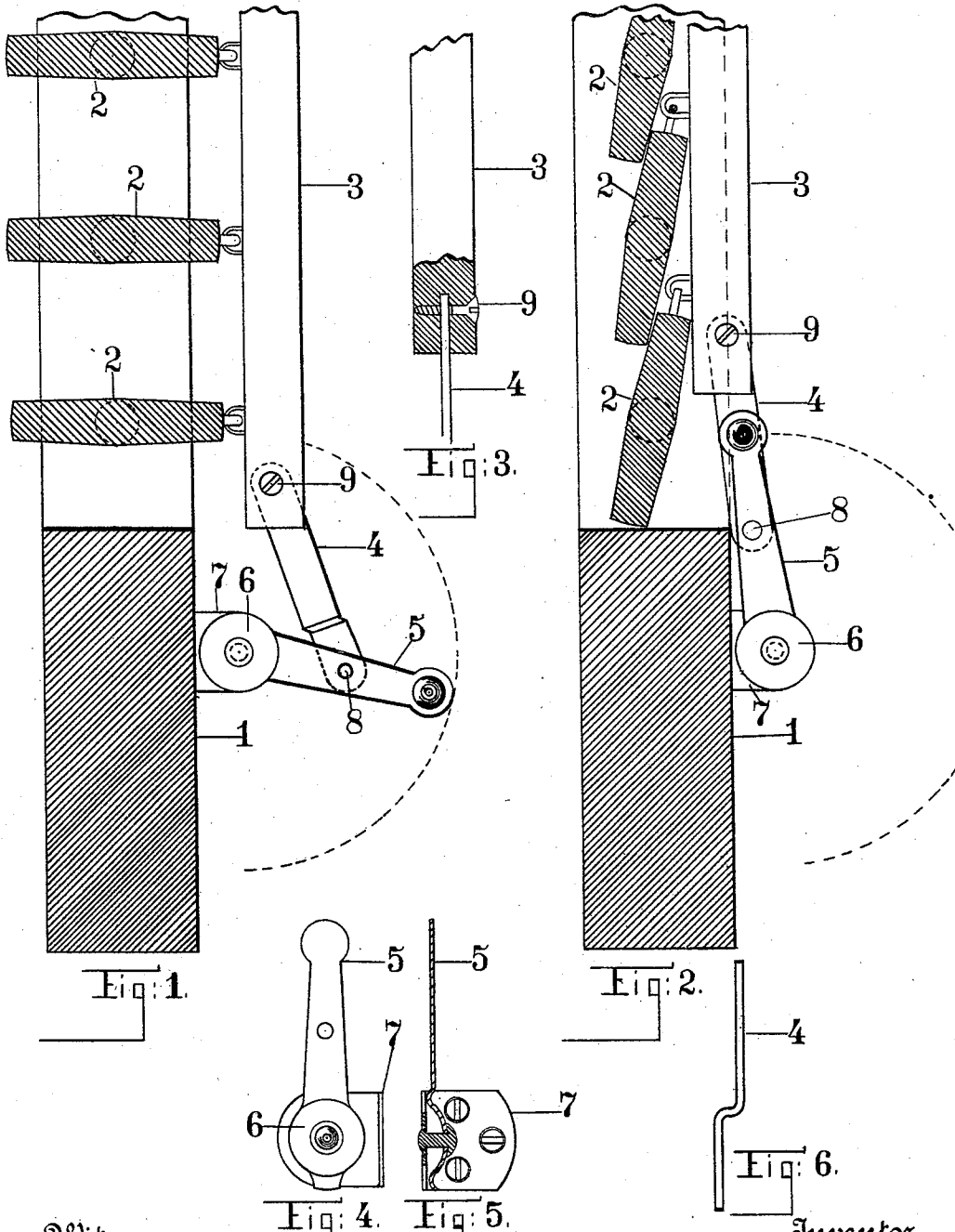

Witnesses
J. F. Harris:
A. M. Turner

Inventor
Alfred Harley:
By his Attorney
H. M. Brown.

A. HARLEY.
BLIND SLAT HOLDER AND FASTENER.

No. 522,593.

Patented July 10, 1894.

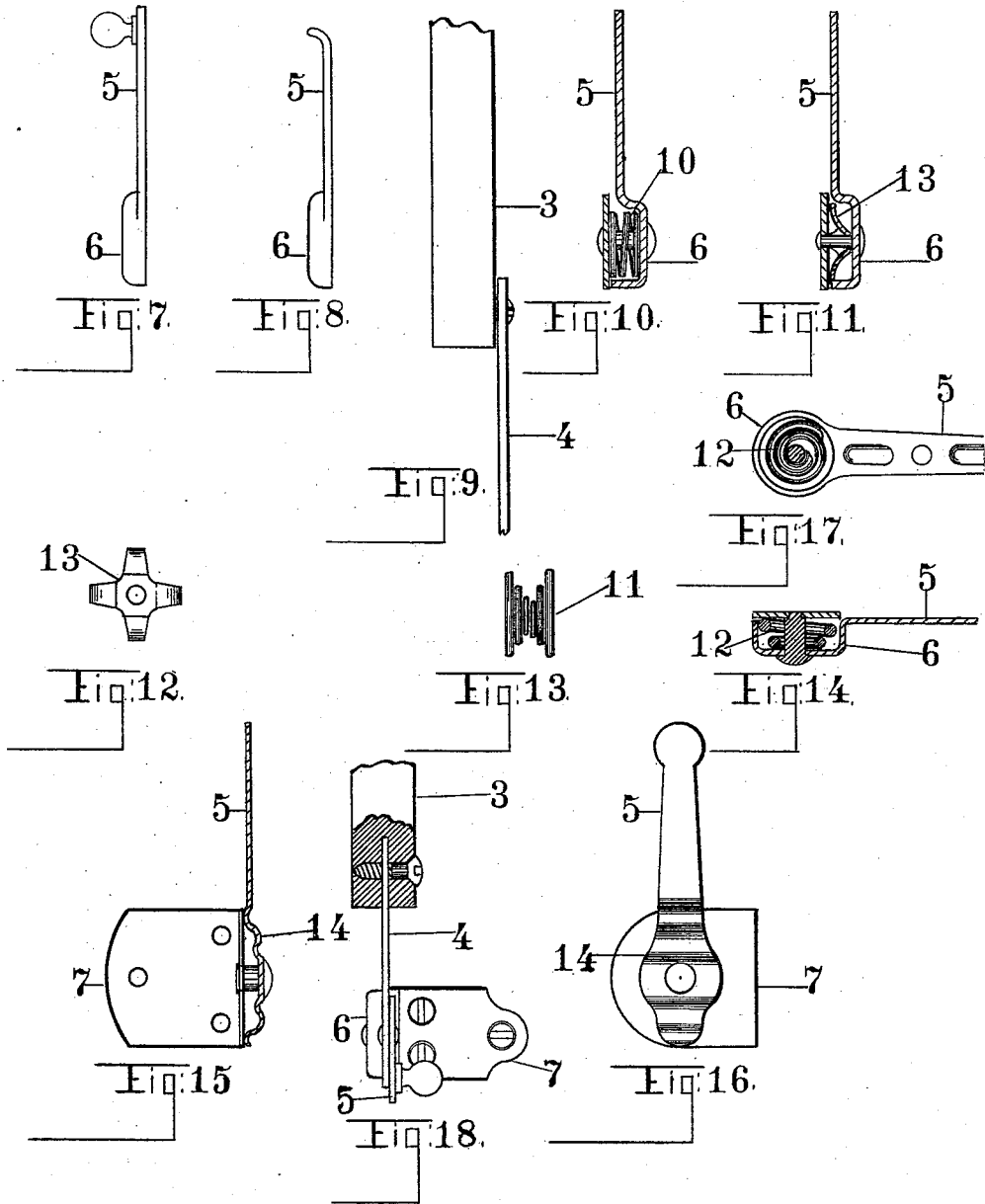

Witnesses
J. F. Harris:
A. M. Turner.

Inventor
Alfred Harley
By his Attorney
A. M. Brown.

UNITED STATES PATENT OFFICE.

ALFRED HARLEY, OF ALBANY, NEW YORK.

BLIND-SLAT HOLDER AND FASTENER.

SPECIFICATION forming part of Letters Patent No. 522,593, dated July 10, 1894.

Application filed September 28, 1893. Serial No. 486,714. (No model.)

To all whom it may concern:

Be it known that I, ALFRED HARLEY, a citizen of the United States of America, residing at Albany, Albany county, New York, have invented certain new and useful Improvements in Blind-Slat Holders and Fasteners; and I do hereby declare the following to be a full, clear, and exact description of the invention, such as will enable others skilled in the art to which it appertains to make and use the same, reference being had to the accompanying drawings, and to the figures of reference marked thereon, which form a part of this specification.

15 The object of my invention is to provide a new and improved automatically controlled blind stop whereby the slats may be turned and retained at any desired angle and when turned so as to be closed they will be locked in position, so that they cannot be opened from the outside.

In the accompanying drawings Figure 1 shows a portion of a blind and slats in vertical section and my apparatus in side elevation showing the slats fully opened; Fig. 2 a similar view of a blind and slats and my apparatus, showing the slats closed and locked fast; Fig. 3 an elevation of the slat rod with a portion of its end broken away, showing the connecting rod and one method of attaching it to the slat rod; Fig. 4 a front elevation of one form of the bracket to which is attached the arm; Fig. 5 a vertical sectional view of the arm shown in Fig. 4, with the bracket in plan; Fig. 6 an edge view of the connecting rod 4, showing that it may have an offset therein, when desired; Fig. 7 a side elevation of one form of my arm, showing a chambered recess at its lower end; Fig. 8 a similar view of the arm, showing the upper end turned over forming a finger catch; Fig. 9 an elevation of a portion of a slat rod and an edge view of a portion of the connecting rod, showing another method of attaching it to the slat rod; Fig. 10 a vertical sectional view of one form of my arm, showing a chamber containing a helical spring, the arm being revoluble about the pivot and on the bottom plate; Fig. 11 a similar view of an arm with a chamber containing a crab plate spring; Fig. 12 is a detail of the crab plate spring;

Fig. 13 a side elevation of a double volute spring for use in the chamber in place of the single volute spring, when desired; Fig. 14 a longitudinal sectional view of the arm and chamber, showing a volute spring therein in vertical section; Fig. 15 a plan view of the bracket and a vertical sectional view of the arm, the larger end of which is corrugated, forming a spring plate attached to the base pivotally; Fig. 16 a plan view of Fig. 15; Fig. 17 a plan view of Fig. 14, showing the volute spring in plan in the chamber, and showing the arm as being embossed to add stiffness thereto; Fig. 18 a vertical elevation of my apparatus shown in Figs. 1 and 2 in operative construction.

The preferred form of my apparatus is shown in Figs. 1, 2, 14, 17 and 18, and when thus constructed it consists of a bracket plate 7 and an arm 5, the larger end of which arm is cup-shaped, forming a chamber for the reception of one of the forms of spring shown and described, but preferably a volute spring either single or double, as shown in Figs. 13, 14 and 17. In this chamber is preferably a volute spring 12, and it is sufficiently compressed to cause and constantly maintain a permanent pressure against the inner surfaces of the chamber, the arm 5 and the chamber being revoluble about the rivet or pivot, the action of such spring 12, therefore, being to cause a permanent unvarying frictional resistance to such movement of the arm 5 and the chamber, the result being that the arm 5 when moved to any point will remain there until designedly moved from its position, the resistance to motion caused by the spring 12 being sufficient to resist any action of the wind on the slats of the blind or any other ordinary disturbing agency. This arrangement will result, further, in having the movement of the arm 5 continuous, uninterrupted or unbroken, *i. e.*, the exact opposite of a step-like or broken movement, and it will be seen that any wear of the meeting surfaces occasioned by the frictional resistance will be automatically taken up by the spring 12, or other form of resilient device used, and that herein lies one of the main advantages of my device over others, *viz.*, that whereas in such other devices the wear

caused by the friction of the parts is not automatically taken up or overcome, but leaves the parts to become loose and worthless unless they are from time to time repaired or tightened up by hand, my device needs no such repairs, as it automatically takes up all such loss caused by such friction by reason of the tension spring 12. To the arm 5 is pivoted the connecting rod 4 at one of its ends, and its other end is pivoted to the slat rod 3 in any well known manner as shown in Figs. 1, 2, 3, 9 and 18.

As one of the main features of my invention is its unvarying frictional resistance to motion, I have shown in the drawings several methods by which unvarying frictional resistance may be accomplished, as follows:

In Figs. 4 and 5 I show an arm 5 with its attached end arched, and corrugations at the base of the arch. This form of the device depends upon the spring of the arch to produce the unvarying frictional resistance desired, the rivet or pivot being set so as to hold the base of the arch snugly in contact with the bracket 7, and so that all wear will be automatically taken up. As the arm 5 is swung around, unvarying frictional resistance takes place at the meeting surfaces of the arch and the bracket.

In Fig. 10 I show the attached end of the arm as being cup-shaped or chambered, and in the chamber 6 a helical spring 10 which is compressed when the rivet or pivot is set, and as the arm 5 swings around, the desired unvarying frictional resistance is caused by the tension on the spring.

In Fig. 11, I show a similar arm with a chamber 6 and a crab plate spring therein, said crab plate spring 13 being shown in plan in Fig. 12. The crab plate spring being resilient is compressed when the rivet is set, and as the arm 5 swings around the crab plate spring exerts a continual frictional resistance to such motion.

In Figs. 15 and 16, I show a corrugated plate spring 14, which acts upon the principle of the arched plate shown in Figs. 4 and 5 but having more corrugations, and therefore more resilience, it is a better form of plate spring.

In Fig. 13, I show a double volute spring 11, which may be used in place of the single volute spring 12, seen in Figs. 14 and 17, in which Fig. 17 is a plan of the interior of the chamber and the volute spring 12, which is also shown in section in Fig. 14.

While I have shown various forms of frictional devices, I prefer the form of volute spring 12 as arranged and shown in Figs. 14 and 17 not, however, confining myself to any particular form or manner of producing such unvarying frictional resistance, whether shown or not.

The operation is as follows:—The bracket of my apparatus being attached to the lower rail of the blind, preferably, and the connect-

ing rod 4 to the slat rod 3, an upward movement of the arm 5 causes movement of the connecting rod 4 about the pivots 8 and 9 and forces the slat rod 3 upwardly until the slats 2 are fully opened, as shown in Fig. 1. The slats 2 will remain in this position until designedly moved, on account of the spring 12 (or any other form of friction producing device that may be used) causing and maintaining a constant and permanent frictional resistance to any movement given the arm 5 or slats 2, requiring greater application of force than is or will be produced by the action of the wind or other ordinary disturbing causes.

If the arm 5 be now thrown upward from its position shown in Fig. 1, to that shown in Fig. 2, the slats will be closed and the pivot 8 will be swung toward the blind and slightly out of line with the pivot 9 and that pivot about which the chamber 6 revolves, or in other words be off center. It will now be impossible for any person, standing in front of the blind to turn the slats so as to open them, as any force exerted to that end from that side of the blind, will only tend to throw the lower end of the lever 4 the closer against the blind. While the lock would be ordinarily secure if the three pivots were in line, yet, when out of line, or off center as shown in Fig. 2, there is no possibility of a sudden jar throwing them out of lock. In Fig. 6, I show the connecting rod 4, which may have an offset in it as shown, when the form of chambered arm 5 shown in Fig. 1 is used, the offset allowing the lever to pass the lip on the bracket 7 and allowing the arm 5 to swing to its lowest point.

I am aware that blind stops have been heretofore made having a step-like or interrupted movement of the actuating arm, produced by ratchet teeth overriding each other, and I disclaim as to all such broken, step-like or interrupted movement of the arm.

I am also aware that blind stops have been heretofore made wherein the frictional resistance was produced by simply causing the surface of the arm or other parts to move on the surface of a base or other object, without having any device or arrangement whereby the wear caused by the friction of the moving parts could be automatically taken up or overcome, and I disclaim as to all such devices, as my device is specially arranged to automatically take up such wear.

Having fully described and illustrated my invention, so that those skilled in the art to which it appertains may make and use the same, what I claim is—

1. A blind stop having a movable arm pivoted to a base, said arm being arranged to have an uninterrupted movement throughout its sweep, and a resilient device arranged to exert an unvarying automatically controlled resistance to movement of said arm, and a connecting rod pivoted to the arm and movably attached to the movable portion of the blind, said connecting rod having an offset

therein arranged to allow the connecting rod to pass the base, as and for the purposes described.

5 2. A blind stop having a movable arm pivoted to a base, the pivoted end being corrugated forming a plate spring and arranged to exert constant unvarying automatically controlled frictional resistance to movement of said arm, and having a connecting rod piv-

oted to the arm and movably attached to the movable portion of said blind, substantially as described.

In testimony whereof I affix my signature in presence of two witnesses.

ALFRED HARLEY.

Witnesses:

HENRY D. WILLIAMS,
WM. E. BURNHAM.