

May 6, 1947.

W. J. ROULEAU

2,420,098

COMPRESSOR

Filed Dec. 7, 1944

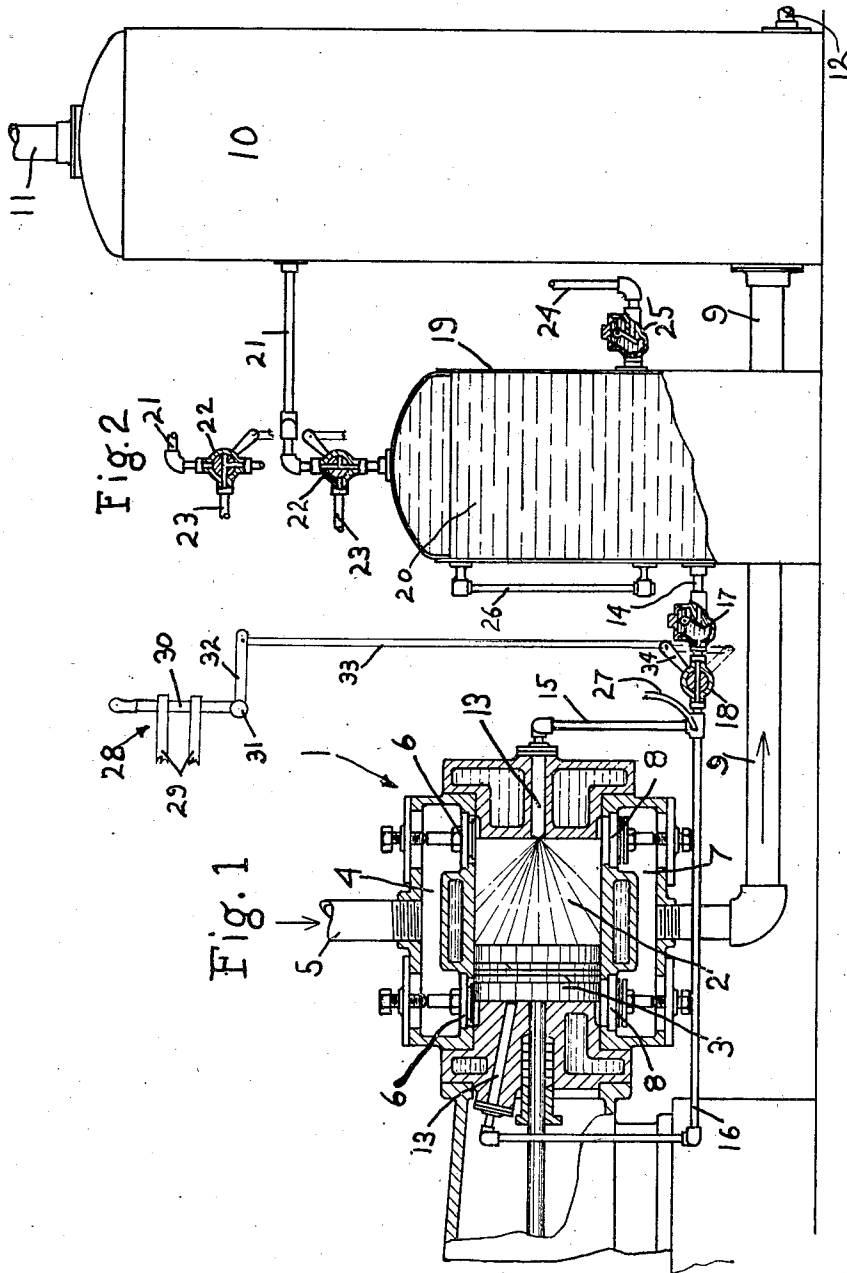

INVENTOR
Wilfred J. Rouleau
PER *Harold Smith Stennant*
ATTORNEYS.

UNITED STATES PATENT OFFICE

2,420,098

COMPRESSOR

Wilfred J. Rouleau, Quincy, Mass.

Application December 7, 1944, Serial No. 566,984

6 Claims. (Cl. 230-206)

1

This invention relates to compressors for compressing air and other gas and particularly to the means for cooling the air as it is compressed thereby to absorb the heat of compression.

One common method employed for thus cooling the air is to spray water into the cylinder during the operation of the compressor, and a pump is usually used for this purpose.

It is an object of my present invention to provide a simplified but novel construction by which the water or other cooling medium will be automatically sprayed into the cylinder without the use of any pump so long as the pressure in the cylinder is less than the maximum pressure developed by the compressor, said spraying operation ceasing as soon as the maximum pressure within the cylinder has been reached.

In order to give an understanding of the invention, I have illustrated in the drawings a selected embodiment thereof which will now be described after which the novel features will be pointed out in the appended claims.

In the drawings:

Fig. 1 is a view partly in section of a compressor embodying my invention.

Fig. 2 is a fragmentary view, also partly in section, showing the shutoff and vent valve for the tank containing the cooling medium.

In the drawings 1 indicates generally a compressor of any suitable or known construction, said compressor being provided with the usual cylinder 2 in which operates the piston 3. The compressor herein shown is of the double acting type, although the invention is equally applicable to a compressor of the single acting type. The compressor is shown as having the usual intake chamber 4 which is supplied with gases to be compressed through the intake pipe 5, said chamber 4 communicating with the cylinder through the medium of the usual inlet valves 6. The compressor is also provided with the usual discharge chamber 7 which communicates with the ends of the cylinder through discharge valves 8, and said chamber 7 is connected by a discharge pipe 9 to a storage tank 10 in which the air or other gas to be compressed is stored. Said tank 10 has a discharge pipe 11 through which the compressed gases may be withdrawn and it also is provided with the usual drain pipe 12. The parts thus far described are such as are commonly found in compressors of this type.

Each cylinder head of the cylinder 2 is provided with a spray nozzle 13 through which water or other cooling medium may be sprayed into the cylinder. These nozzles 13 are supplied with the

2

cooling medium through a supply pipe 14 which is provided with two branches 15 and 16, one leading to one of the nozzles 13 and the other leading to the other nozzle 13. The supply pipe 14 is illustrated as having a check valve 17 therein and also a shutoff valve 18.

In accordance with my present invention I provide a tank 19 which contains the water or other cooling medium 20 and to which the supply pipe 14 is connected. The tank 19 is connected to the storage tank 10 so that the cooling medium 20 in the tank 19 is subjected to the same pressure as that in the storage tank.

For this purpose the upper end of the tank 19 is connected by a pipe 21 to the storage tank and as will be obvious by this means the cooling medium in the tank 20 is continuously subjected to the pressure in the storage tank 10. With this construction and so long as the shutoff valve 18 in the pipe 14 is open, the pressure to which the cooling medium 20 in the tank 19 is subjected will force cooling medium through each nozzle 13 so long as the pressure in the corresponding end of the cylinder chamber is less than the pressure in the storage tank 10. When, however, during the compression stroke the pressure in the cylinder 2 has reached its maximum and the corresponding discharge valve 8 opens to permit discharge of the compressed gas, the delivery of a spray of water from the nozzle 13 will cease because of the fact that the pressure at the discharge end of the nozzle has been equalized with that on the cooling medium in the tank 19.

The piston 3 in Fig. 1 is shown as at the left hand end of its stroke, and during its movement toward the left, which is its suction stroke for the right hand end of the cylinder, the pressure in the cylinder will be less than that in the storage tank, and therefore less than that to which the cooling medium 20 in the tank 19 is subjected, and therefore, the cooling medium will be automatically sprayed into the cylinder as shown in Fig. 1. During the movement of the piston 3 to the right, the air or gas in the cylinder will be compressed until finally the pressure in the cylinder is equal to that in the storage tank at which time the discharge valve 8 will open and the compressed gas will be forced from the cylinder into the storage tank. As soon as the pressure in the cylinder has been built up so as to equalize that in the storage tank, further delivery of cooling medium through the nozzle 13 will cease and the cooling medium will only again be delivered from the

3

nozzle 13 when the piston begins its suction stroke.

With this construction the use of any pump or other similar machinery for forcing the cooling medium through the spray nozzles is entirely eliminated, and thereby the construction and operation of the cooling means for the compressor is much simplified.

I propose to incorporate in the pipe 21 a three-way valve 22 by which the communication between the storage tank 10 and the tank 19 may be closed and the tank 19 may be vented through a vent pipe 23. 24 indicates a supply pipe through which added cooling water or other cooling medium may be supplied to the tank 19 when necessary. This pipe 24 has a check valve 25 therein to prevent any back flow through the pipe 24.

The tank 19 is also shown as being equipped with a gauge 26 by which the level of the cooling medium 20 therein may be observed.

When the cooling medium in the tank 19 is near exhaustion, then the valve 22 is turned into the position shown in Fig. 2, thereby cutting off communication between the storage tank 10 and the tank 19 and opening said tank to the atmosphere through the vent pipe 23. Water or other cooling medium will then be supplied to the tank through the supply pipe 24 and when the tank is filled, the valve 22 is again moved into position to cut off the vent but to open communication between it and the storage tank 10.

The spraying of water into the cylinder of the compressor has a tendency to wash out of the cylinder the lubricant necessary to properly lubricate the piston. In order to prevent such loss of lubricant, I propose to supply a suitable lubricating liquid to the pipe 14 so that said lubricating liquid will mingle with the cooling medium and thus be delivered to the cylinder with the spray. For this purpose, there is shown a lubricant supplying pipe 27 which is connected into the pipe connection 14. Any suitable liquid lubricant may be supplied to the pipe 27. One lubricant which is suitable for this purpose is colloidal graphite which is known by the trade name "Aquadag." By this means a sufficient amount of lubricant for properly lubricating the piston is being constantly fed to the cylinder, thereby avoiding any possibility of insufficient lubrication due to the presence of the spray.

While the shutoff valve 18 may be operated in any suitable way whenever it is desired to close or open the communication between the tank 19 and the nozzles 13, yet I have herein illustrated means for operating said valve in conjunction with the control switch by which the motor for the compressor is started and stopped, so that when the motor circuit is opened and the compressor ceases to operate, the valve 18 will be automatically closed, thus shutting off the supply of cooling medium to the nozzles, while when the switch is operated to close the motor circuit and start up the compressor, the valve 18 will be open so as to permit delivery of cooling medium to the nozzles.

I have shown more or less diagrammatically at 28 a knife switch of any usual construction for opening and closing the circuit of the motor by which the compressor is operated, such switch including the two contacts 29 and the knife contact 30 which is pivoted at 31 and which can be turned about its pivot to open and close the switch. The swinging contact 30 has rigid there-with an arm 32 which is connected by a link 33

4

with an arm 34 by which the valve 18 is opened or closed.

The connection between the switch and the valve is such that when the switch is closed as shown in Fig. 1, the valve 18 will be open so as to allow delivery of cooling medium to the nozzles while the compressor is operating. When however, the switch blade 30 is swung to the right to open the switch, this movement will operate through the arm 32 and link 33 to swing the valve arm 34 into the dotted line position, thereby closing the shutoff valve 18. With this construction, the delivery of cooling medium to the nozzles is automatically terminated when the compressor is shut down, and delivery is automatically re-established when the switch is closed to start up the compressor.

If desired, the three-way valve 22 may be operated automatically by means of a float that in turn is controlled by the level of the cooling medium in the tank 19. Inasmuch as floats for opening and closing a valve are used in a number of different arts, I have not thought it necessary to illustrate the float herein.

I claim:

1. A compressor for compressing air and other gases comprising a cylinder, a piston operating therein, a spray nozzle to deliver cooling medium to the cylinder, a tank containing the cooling medium, means connecting the tank to the nozzle, and means for maintaining in the tank a pressure substantially equal to the maximum pressure developed by the compressor, whereby cooling medium will be automatically delivered from the nozzle into the cylinder of the compressor except when the pressure in said cylinder equals or exceeds that in the tank.

2. A compressor for compressing air and other gases comprising a cylinder, a piston operating therein, a spray nozzle to deliver cooling medium to the cylinder, a storage tank to receive the gases compressed by the compressor, a second tank containing the cooling medium, means connecting said second tank to the nozzle, and means connecting said second tank to the storage tank whereby the cooling medium in the second tank will be consequently subjected to the pressure in the storage tank and will thus be constantly forced through the nozzle into the cylinder except when the maximum pressure has been developed in said cylinder.

3. A compressor for compressing air and other gases comprising a cylinder, a piston operating therein, a spray nozzle to deliver cooling medium to the cylinder, a tank containing the cooling medium, means connecting the tank to the nozzle, means for maintaining in the tank a pressure substantially equal to the maximum pressure developed by the compressor, whereby cooling medium will be automatically delivered from the nozzle into the cylinder of the compressor except when the pressure in said cylinder equals or exceeds that in the tank, and means for delivering a lubricant to the cooling medium prior to its delivery from the nozzle.

4. A compressor for compressing air and other gases comprising a cylinder, a piston operating therein, a spray nozzle to deliver cooling medium to the cylinder, a tank containing the cooling medium, means connecting the tank to the nozzle, means for continuously subjecting the cooling medium in the tank to the maximum pressure developed by the compressor, whereby cooling medium will be automatically delivered from the nozzle into the cylinder of the compressor ex-

5

cept when the pressure in said cylinder equals or exceeds that in the tank, and means for automatically closing the communication between the tank and the nozzle when the compressor ceases operation.

5. A compressor for compressing air and other gases comprising a cylinder, a piston operating therein, a spray nozzle to deliver cooling medium to the cylinder, a tank containing the cooling medium, means connecting the tank to the nozzle, means for continuously subjecting the cooling medium in the tank to the maximum pressure developed by the compressor, whereby cooling medium will be automatically delivered from the nozzle into the cylinder of the compressor except when the pressure in said cylinder equals or exceeds that in the tank, and means for automatically closing the communication between the tank and the nozzle when the compressor ceases operation and for automatically opening said communication when the compressor is started in operation.

6. A compressor for compressing air and other gases comprising a cylinder, a piston operating therein, a spray nozzle to deliver cooling medium to the cylinder, a tank containing the cooling

6

medium, a pipe connection between said tank and the nozzle, means for maintaining in the tank a pressure substantially equal to the maximum pressure developed by the compressor, whereby cooling medium will be automatically delivered from the nozzle into the cylinder of the compressor except when the pressure in said cylinder equals or exceeds that in the tank, and a check valve in said pipe connection which permits flow of cooling medium from the tank to the nozzle but prevents flow in a reverse direction.

WILFRED J. ROULEAU.

REFERENCES CITED

The following references are of record in the file of this patent:

UNITED STATES PATENTS

Number	Name	Date
224,081	Eckart	Feb. 3, 1880
233,432	Pitchford	Oct. 19, 1880
268,348	Wood et al.	Nov. 28, 1882
294,299	Ostergren	Feb. 25, 1902
2,042,991	Harris	June 2, 1936