

(21) Application No 9101706.1

(22) Date of filing 17.12.1987

Date lodged 25.01.1991

(30) Priority data
(31) 944273

(32) 19.12.1986

(33) US

(62) Derived from Application No 8729405.4 under Section 15(4) of the Patents Act 1977

(71) Applicant
Olin Corporation

(Incorporated in the USA - Virginia)

350 Knotter Drive, Cheshire, Connecticut 06410-0586,
United States of America

(72) Inventor
David William Cawfield

(74) Agent and/or Address for Service
D Young & Co
10 Staple Inn, London, WC1V 7RD, United Kingdom

(51) INT CL⁵
C25B 13/02 9/00 // C25B 1/14

(52) UK CL (Edition K)
C7B BEJB B148 B234 B279 B786

(56) Documents cited		
GB 2127856 A	EP 0248433 A	EP 0206032 A
US 4770756 A	US 4761216 A	US 4752369 A
US 4743350 A	US 4105514 A	US 4014775 A

(58) Field of search
UK CL (Edition K) C7B BDAA BDAC BDAD BEAM
BECE BEJB
INT CL⁵ C25B

(54) Membrane electrolytic cell incorporating separator

(57) In an electrolytic membrane cell eg. a filter press cell for the electrochemical production of an alkali metal hydrosulfite by the reduction of an alkali metal biosulfite component of a circulated aqueous catholyte solution comprising anode 11, porous cathode plate 26 and a membrane 25, a separator 21 is provided intermediate the anode surface and membrane to prevent the membrane from touching the adjacent anode surface, the separator having a frame 22 and a mesh portion 24 treated with a hydrophilic coating eg. of titanium dioxide to prevent adherence of gas bubbles.

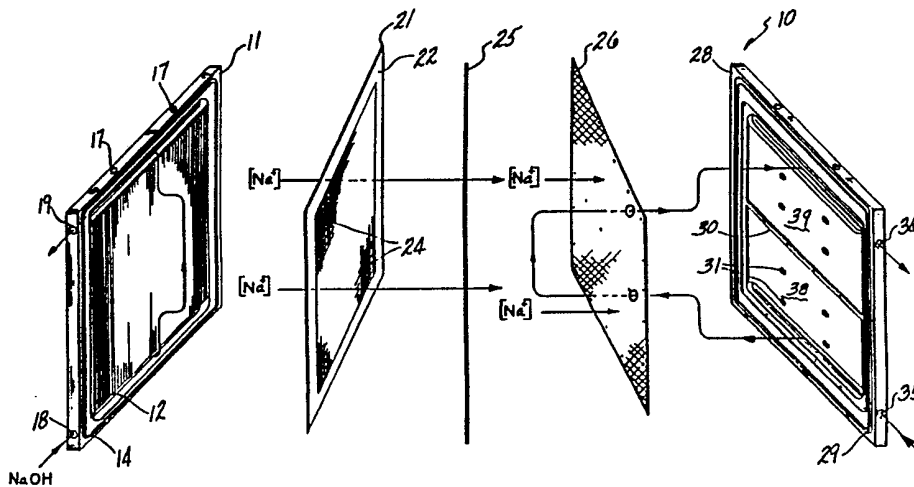

FIG-1

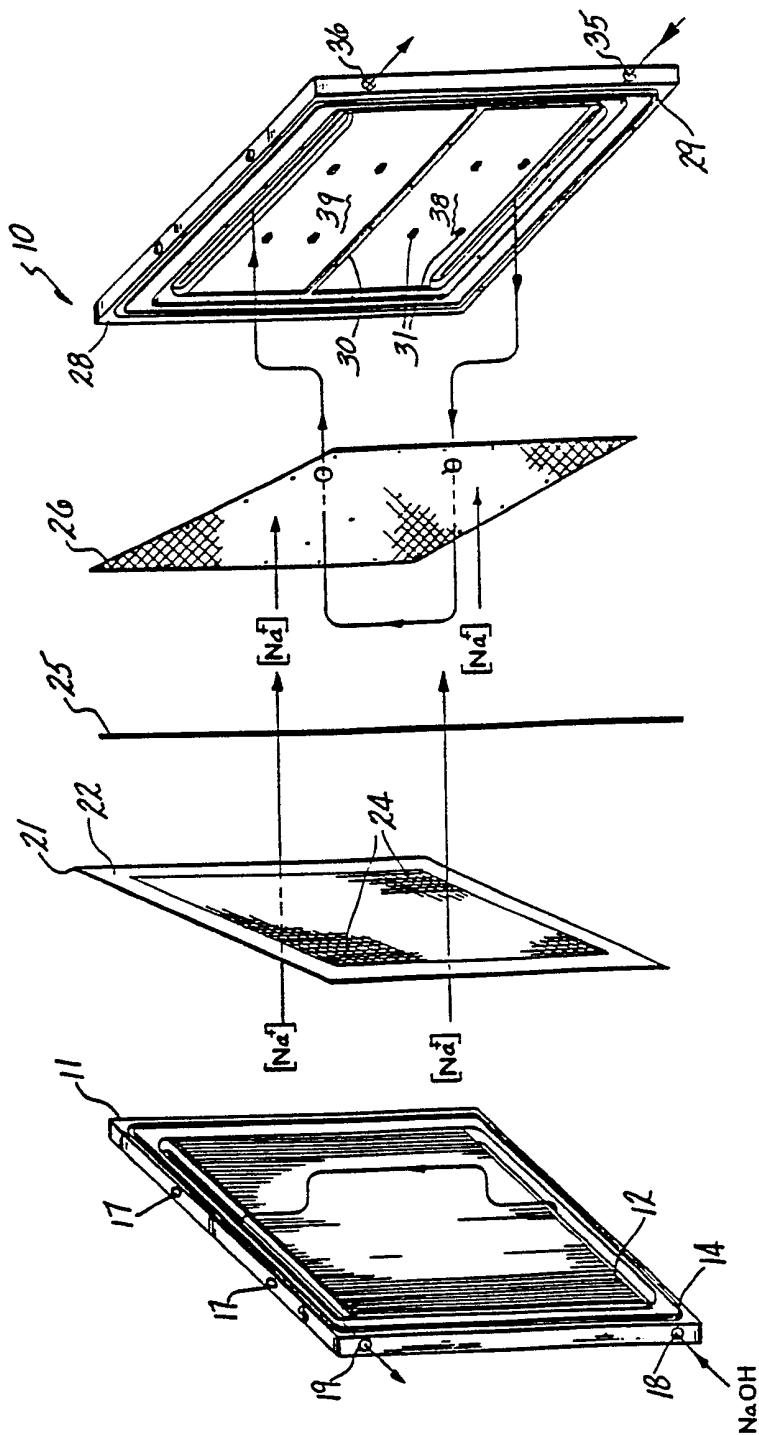

FIG-1

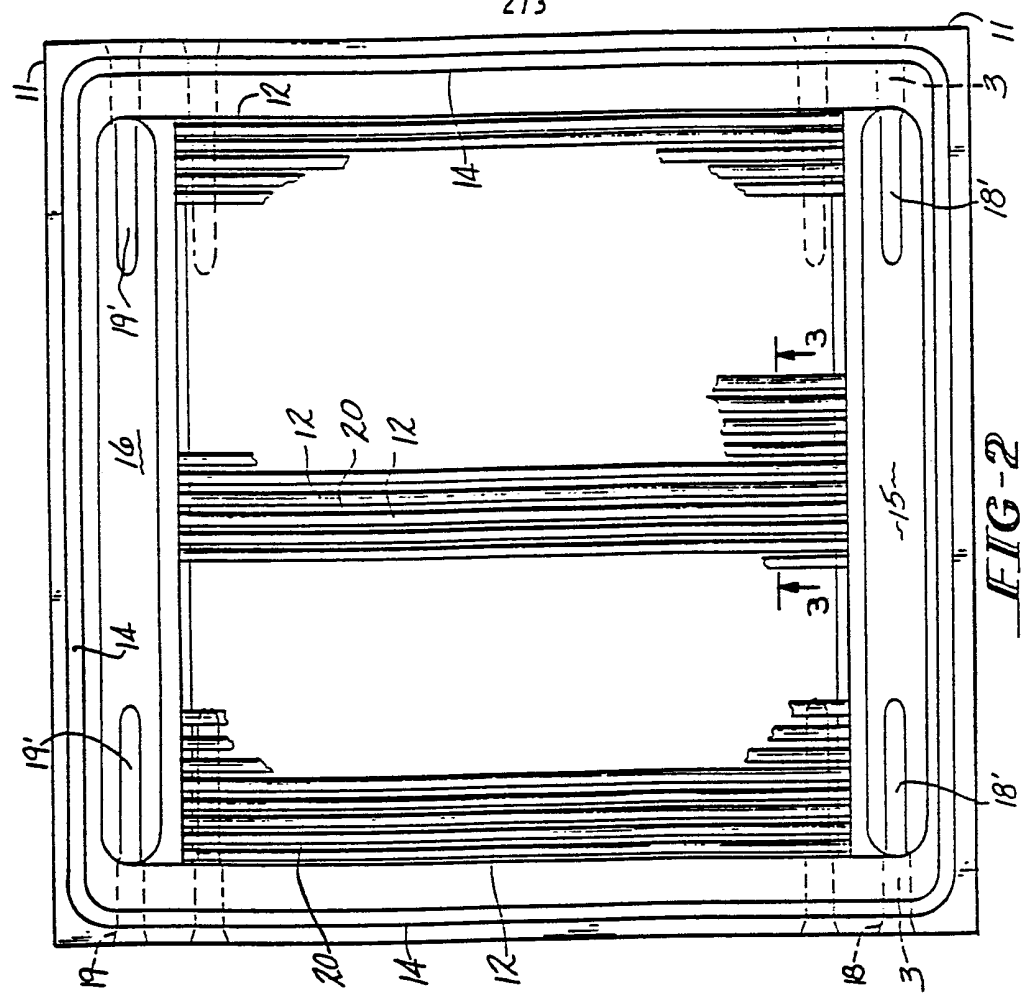

FIG-2

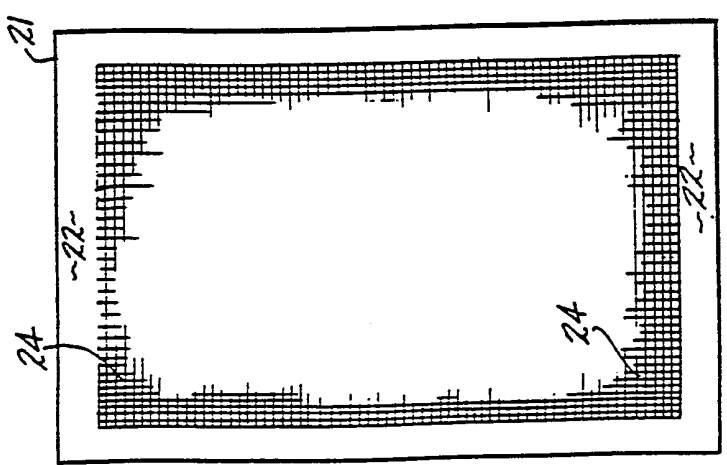

FIG-6

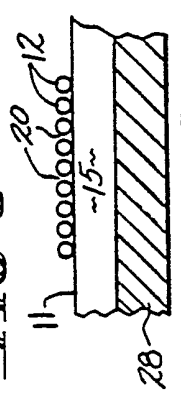

FIG-3

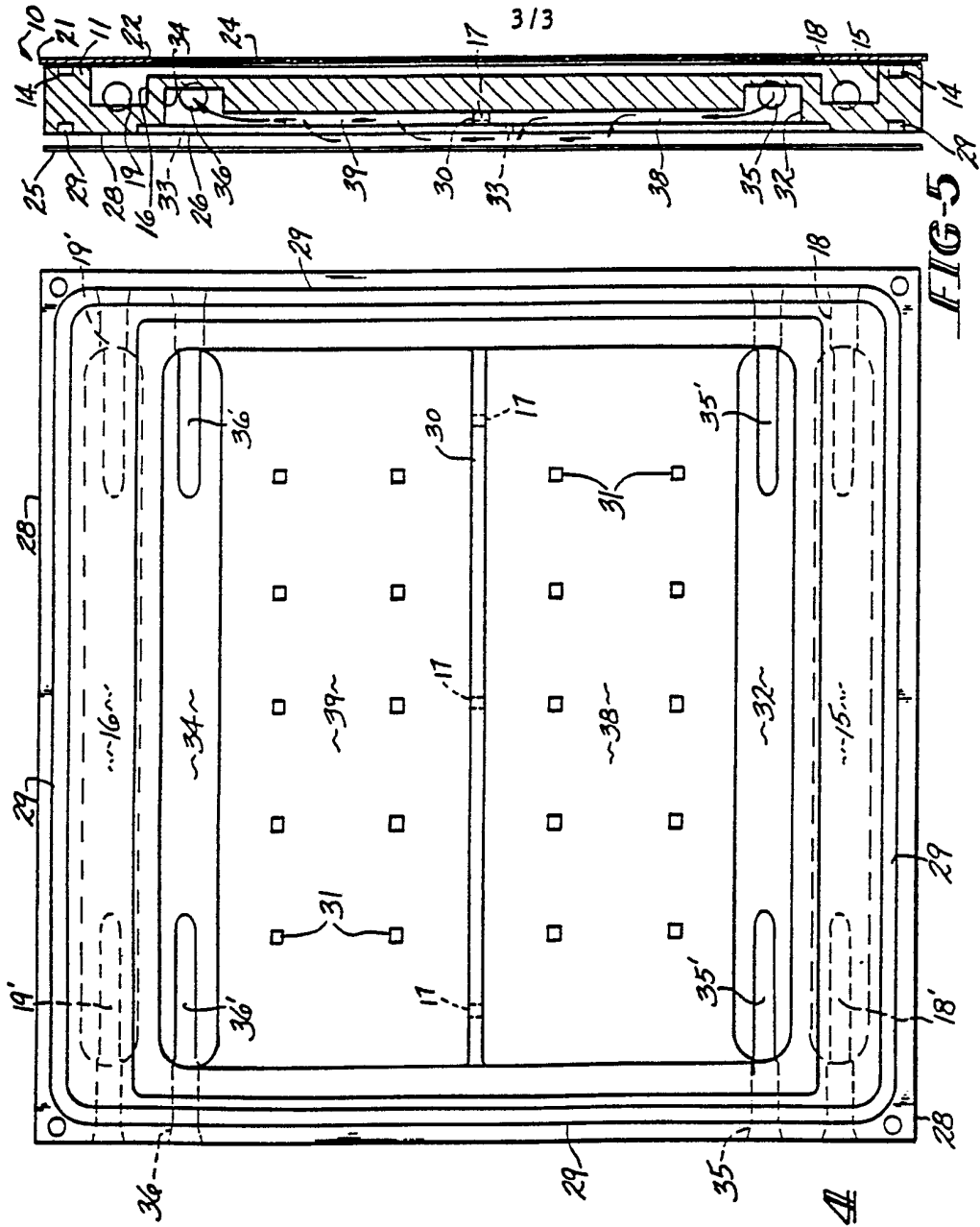

FIG-4

FIG-5

-1-

ELECTROLYTIC CELL

BACKGROUND OF THE INVENTION

This invention relates generally to electrolytic cells and particularly to such cells which are suitable for the electrochemical manufacture of aqueous solutions of hydrosulfites. More particularly, the present invention relates to an electrochemical membrane cell for the commercial production of concentrated hydrosulfite solutions at high current densities and to the catholyte flow path within the cell.

Many unsuccessful attempts have been made at developing a process for manufacturing alkali metal hydrosulfites, such as sodium hydrosulfite or potassium hydrosulfite, electrochemically that can compete commercially with conventional zinc reduction processes using either sodium amalgam or metallic iron. The electrochemical process for making hydrosulfite involves the reduction of bisulfite ions to hydrosulfite ions. For this process to be economical,

current densities must be employed in a cell which are capable of producing concentrated hydrosulfite solutions at high current efficiencies.

Further, where the solutions, which are strong reducing agents effective as bleaching agents, are to be used in the paper industry, the undesirable byproduct formation of thiosulfate as an impurity from hydrosulfite must be minimized. At high concentrations of hydrosulfite, however, this byproduct reaction becomes more difficult to control.

Additionally, prior electrochemical routes to hydrosulfite have produced aqueous solutions which are unstable and decompose at a rapid rate. This high decomposition rate of hydrosulfite appears to increase as the pH decreases or the reaction temperature increases. One approach to control the decomposition rate is to decrease the residence time of the solution in the cell and to maintain the current density as high as possible up to a critical current density above which secondary reactions will occur due to polarization of the cathode.

Some of the processes of the prior art, which claim to make hydrosulfite salts electrochemically, require the use of water-miscible organic solvents, such as methanol, to reduce the solubility of the hydrosulfite and prevent its decomposition inside the cell. The costly recovery of the methanol and hydrosulfite makes this route uneconomical.

The use of zinc as a stabilizing agent for hydrosulfites in electrochemical processes has also been reported, but because of environmental considerations, this is no longer commercially practical or desirable.

More recently, U.S. Patent No. 4,144,146 issued March 13, 1979 to B. Leutner et al describes an

electrochemical process for producing hydrosulfite solutions in an electrolytic membrane cell. The process employs high circulation rates for the catholyte which is passed through an inlet in the bottom of the cell and removed at the top of the cell to provide for the advantageous removal of gases produced during the reaction. Catholyte flow over the surface of the cathodes is maintained at a rate of at least 1 cm per second and the cathode is formed of fibrous mats of compressed sintered fibers with a mesh spacing of 5 mm or less. The process is described as producing concentrated solutions of alkali metal hydrosulfites at commercially viable current densities; however, the cell voltages required are high, being in the range of 5 to 10 volts. This results in excessive energy consumption. There is no indication of the concentrations of thiosulfate impurity in the product solutions.

Therefore, there is still a need for a commercially practical electrochemical cell design for producing aqueous solutions of alkali metal hydrosulfites having low concentrations of alkali metal thiosulfates as impurities at high current densities and at reduced cell voltages.

SUMMARY OF THE INVENTION

According to one aspect of the invention, there is provided an electrolytic cell having a top and a bottom, with provision for an anolyte and a catholyte to flow therethrough, comprising in combination

- (a) an anode;
- (b) a cation exchange membrane, adjacent the anode;
- (c) separator means intermediate the anode and the membrane to prevent the membrane from touching the anode;
- (d) a porous cathode plate having a first surface adjacent the membrane and an opposite second surface; and
- (e) a cathode backplate adjacent the opposite second surface of the cathode plate having a substantially horizontal flow barrier extending thereacross defining an upper catholyte chamber and a lower catholyte chamber, the flow barrier interrupting the catholyte flowing between the top and the bottom of the cell causing substantially all of the catholyte to change flow direction and pass twice through the porous cathode plate, transverse to the first surface and the opposite second surface of the cathode plate, to pass beyond the flow barrier and to exit the cell.

According to another aspect of the invention, there is provided an electrolytic cell having a top and a bottom with provision for an anolyte and a catholyte to flow therethrough, comprising in combination

- (a) a plurality of adjacently positioned bipolar cell bodies each providing an anode backplate and a cathode backplate;
- (b) a plurality of porous cathode plates each having a first surface and an opposite second surface, the opposite second surface being adjacent the cathode backplate;
- (c) a cation exchange membrane intermediate each pair of adjacently positioned anode surfaces and cathode plate first surfaces; and
- (d) separator means intermediate each anode

surface and membrane to prevent the membrane from touching the adjacent anode surface, the separator means further having a frame portion about its exterior and a hydrophilically treated mesh portion interiorly connected thereto adjacent each anode surface and membrane.

According to another aspect of the invention, there is provided an electrolytic cell having a top and a bottom with provision for an anolyte and a catholyte to flow

therethrough, comprising in combination:

(a) a plurality of adjacently positioned bipolar cell bodies each providing an anode backplate and a cathode backplate;

(b) a plurality of porous cathode plates each having a first surface and an opposite second surface adjacent the cathode backplate;

(c) a cation exchange membrane intermediate each pair of adjacently positioned anode surfaces and cathode plate first surfaces;

(d) separator means intermediate each anode surface and the membrane to prevent the membrane from touching the adjacent anode surface, the separator means having a mesh portion adjacent each anode surface and membrane;

(e) a substantially horizontal flow barrier on each cathode backplate extending thereacross to define an upper catholyte chamber and a lower catholyte chamber, the flow barrier further interrupting the flow of catholyte between the top and the bottom of the cell causing substantially all of the catholyte to change flow direction and pass through the porous cathode plate transverse to the first surface and the opposite second surface of the cathode plate as the catholyte passes beyond the flow barrier; and

(f) a plurality of vertically positioned

substantially parallel flow directing means comprising the anode surface on each bipolar electrode, the flow directing means having a gap between each adjacent pair of flow directing means to thereby form a plurality of flow channels for the anolyte between the top and the bottom of the cell.

According to another aspect of the invention, there is provided an electrolytic cell having a top and a bottom with provision for an anolyte and a catholyte to flow therethrough, comprising in combination

(a) a plurality of adjacently positioned generally vertically aligned bipolar cell bodies each providing an anode backplate and a cathode backplate, each cathode backplate having an upper catholyte compartment adjacent the top of the electrolytic cell and a lower catholyte compartment adjacent the bottom of the electrolytic cell separated by a barrier that extends horizontally and thereby obstructs the direct flow of catholyte between the upper catholyte compartment and the lower catholyte compartment;

(b) a plurality of porous generally vertically aligned cathode plates each having a first surface and an opposite second surface, the opposite second surface being adjacent the cathode backplate;

(c) a vertically aligned cation exchange membrane intermediate each pair of adjacently positioned anode surfaces and cathode plate first surfaces; and

(d) vertically aligned separator means intermediate each cathode plate first surface and membrane to prevent the membrane from touching the adjacent cathode plate first surface, the separator means further having a frame portion about its exterior and a mesh portion interiorly connected thereto adjacent each cathode plate first surface and membrane.

According to another aspect, the invention provides a compressed and sintered electrode for use in an electrochemical cell, wherein it comprises in combination at least:

- (a) a support layer formed of perforated material;
- (b) a second layer of fibers atop of the support layer; and
- (c) a third layer of fibers, the fibers being smaller in diameter than the fibers of the second layer and being positioned atop of the second layer.

Aims and features of the preferred forms of the invention described hereinafter include:-

- (1) An electrochemical membrane cell for producing aqueous alkali metal hydrosulfite solutions having low concentrations of alkali metal thiosulfates as impurities.
- (2) An electrochemical membrane cell which operates at high current densities to produce concentrated alkali metal hydrosulfites.
- (3) An electrolytic membrane cell that utilizes an improved catholyte flow path to achieve multiple passes through the porous cathode transverse to the surface of the cathode.
- (4) A monolithic cell body structure with the bipolar cell body or backplates being fabricated from a single piece of metal.
- (5) The catholyte flow path forces the catholyte to make multiple passes through the multilayered porous cathode formed of sintered wire strands held in place between a perforated plate and a mesh screen.
- (6) A cathode flow barrier is employed to direct the catholyte flow stream through the cathode.
- (7) The anode employs a plurality of parallel smooth surfaced, vertically positioned wire rods.
- (8) The anode employs a separator screen or mesh with a hydrophilically treated surface to separate the anode rods from the membrane.
- (9) The membrane is maintained in position against the separator screen or mesh during operation by hydraulic pressure and the total anolyte compartment volume is between the anode wire rods and separator screen or mesh and within the interstices of that screen or mesh.
- (10) Even current distribution is achieved across the electrolytic membrane cell.
- (11) A catholyte compartment of low volume results in short cell residence time for the cell electrolytes and,

consequently, less product decomposition and low thiosulfate impurity formation.

(12) The cell design results in reduced gas bubble build-up on the membrane surface which aids in reducing electrical power consumption and results in lower actual cathode current density.

(13) A monolithic cell electrode design results in lower electrical voltage loss during cell operation, while the machined fluid distribution slots or conduits reduce erosion corrosion.

(14) An electrolytic membrane cell for the electrochemical production of an alkali metal hydrosulfite by the reduction of an alkali metal bisulfite component of a circulated aqueous catholyte solution in a cell having an improved extended surface multipass porous cathode, an improved catholyte flow path, an improved anode consisting of a plurality of parallel vertically positioned wire rods that are separated from the cation exchange membrane by a separator mesh that is hydrophilically treated on its surface to produce the alkali metal hydrosulfite at a low cathode current density and by passing at least 30 percent by volume of the catholyte solution through the porous cathode.

BRIEF DESCRIPTION OF THE DRAWINGS

Preferred embodiments of the invention will now be described by way of example with reference to the accompanying drawings wherein:

FIGURE 1 is a diagrammatic exploded view of an electrolytic cell showing the electrolyte flow paths and the ion flow paths;

FIGURE 2 is a side elevational view of the anode side of the bipolar cell electrode showing a portion of the anode rods that cover the anode backplate, further having some of these shown rods broken away;

FIGURE 3 is an enlarged partial sectional view taken along the lines 3--3 of FIGURE 2 showing the anode rods as they are fastened to the electrode;

FIGURE 4 is a side elevational view of the cathode side of the bipolar electrode;

FIGURE 5 is a side sectional view of the bipolar electrode element of the electrolytic cell showing the flow path of the catholyte through the porous cathode in the cathode compartment from the catholyte distribution slots to the catholyte collection slots or conduits; and

FIGURE 6 is a side elevational view of the separator screen that is positioned between the anode rods and the membrane.

DETAILED DESCRIPTION OF THE PREFERRED EMBODIMENTS

As seen in the exploded and partially diagrammatic illustration in FIGURE 1, a filter press membrane electrolytic cell, indicated generally by the numeral 10, is shown consisting of an anode backplate 11, separator means 21, cation selective membrane 25, a porous cathode plate 26, and a cathode backplate 28.

The anode backplate 11 and cathode backplate 28 form the opposing sides of a bipolar electrode, which can be machined from a stainless steel plate or can be cast stainless steel. The stainless steel plate can, for example, be formed of 304L or 316 stainless steel as thick as 1 1/4" which is resistant to corrosion and is simply fabricated by machining the flat plate to create chambers through which the anolyte and catholyte fluids can pass into their respective anolyte and catholyte chambers. The thickness of the stainless steel plate provides stiffness and an extremely precise flatness to the structure. The cathode plate 26 is mounted to the cathode plate 28 by screws (not shown) which are screwed into cathode support pedestals 31, while the anode rods 12 may be welded, such as by TIG welding, in place without warping the stainless steel plate.

The anode structure can be seen in greater detail in FIGURES 2-4. As seen in FIGURE 2, the anode backplate 11 has a plurality of parallel positioned, vertically extending anode rods 12 welded at the top and bottom portions of the rods to the anode backplate 11. These rods 12 extend across the entire width of the anode backplate 11, although for simplicity of illustration the continuous side-by-side arrangement has not been shown in FIGURE 2 since rods in the central portion of the anode backplate 11 have been

omitted entirely. These rods are, for example, 1/8" diameter nickel wire rods spaced apart from each other to create an anode inter-rod gap 20 of approximately 1/16" between adjacent rods. These anode rods 12 can be formed from nickel 200, or any other corrosion resistant composition providing low overvoltage characteristics. The vertical positioning of the anode rods 12 with the anode inter-rod gap 20, see briefly FIGURE 3, provides clear flow channels from the bottom of the anode backplate 11, where the anolyte fluid enters via anolyte entry ports 18 into an anolyte distribution groove 15, to the top. Anolyte fluid flows vertically upwardly in the anode inter-rod gaps 20 to the anolyte collection groove 16 before the liquid exits the cell through the anolyte exit ports 19. The vertical positioning of the anode rods 12 provides even current distribution across the anode and avoids gas blinding that can occur from the buildup of gas bubbles, which can consequently reduce the current density in the operating cell.

Both the anolyte entry ports 18 and the anolyte exit ports 19 have transition slots 18' and 19', respectively, that are machined into the stainless steel plate. The anolyte entry port transition slots 18' are machined into the anolyte distribution groove 15 to provide a smooth transition surface that is tapered and avoids erosion corrosion which can interfere with the smooth flow of the anolyte into the cell 10 and which will provide metal contamination as the erosion and corrosion occurs. The anolyte exit port transition slots 19' are both similarly positioned and machined.

An anode gasket groove 14 is machined into the anode backplate 11 about the entire periphery. The groove, for example, is 3/8" wide by 3/16" deep to receive a rectangular anode gasket (not shown) that is 3/8" wide by 3/8" deep. This gasket can have a strip of material, such as material sold under the tradename of GORE-TEX or TEFLON, positioned over the gasket to come into contact with the plastic separator means 21 when the cell is compressed and assembled.

The plastic separator means 21 is formed from any material resistant to anolyte corrosion, and preferably polypropylene has been employed. An 8 mesh polypropylene fabric with an approximately 40% open area has been successfully employed, as has a titanium dioxide filled polyethylene mesh. The separator means 21 has a separator frame 22 that is solid about the periphery and a separator mesh 24 on the interior of the separator frame 22. The mesh 24 is treated with a hydrophilic coating to prevent gas bubbles from adhering to the mesh and the adjacent membrane by capillary action. A coating of titanium dioxide applied to the mesh 24 has been successfully employed as the hydrophilic coating. Preventing the buildup of gas bubbles on the membrane and in the mesh avoids cell voltage fluctuations during operation.

The use of the separator means 21 also has successfully prevented the buildup of regions of locally high acidity in the adjacent membrane where the membrane touches against the nickel anode rods 12. Having the membrane 25 touch against the nickel anode rods 12 can create pockets of high acidity because the sulfur species become oxidized to sulfuric acid due to the slow migration of the sulfur species back through the membrane during operation of the cell. The nickel oxide coating on the anode rods 12 breaks down and

nickel corrosion occurs. This corrosion is transported through the membrane to the cathode side of the cell 10. There this nickel corrosion is reduced to the metallic state by the hydrosulfite solution. This metallic state nickel adheres tightly to the membrane on the cathode side and will impair the transport of ions and fluid through the membrane.

The anode has been designed so that the anolyte which is electrolyzed in the cell 10 is any suitable electrolyte which is capable of supplying alkali metal ions and water molecules to the cathode compartment. Suitable anolytes are, for example, alkali metal halides, alkali metal hydroxides, or alkali metal persulfates. The selection of anolyte is in part dependent on the product desired. Where a halogen gas such as chlorine or bromine is wanted, an aqueous solution of an alkali metal chloride or bromide is used as the anolyte. Alkali metal hydroxide solutions are chosen where oxygen gas or hydrogen peroxide is to be produced. If persulfuric acid is the desired product, an alkali metal persulfate is employed. However, alternative materials of construction, such as titanium group metals for the anolyte wetted parts with an alkali metal chloride anolyte, would be necessary for each particular anolyte utilized.

In any case, concentrated solutions of the electrolyte selected are employed as the anolyte. For example, where sodium chloride is selected as the alkali metal chloride, suitable solutions as anolytes contain from about 12 to about 25 percent by weight of NaCl. Solutions of alkali metal hydroxides, such as sodium hydroxide, contain from about 5 to about 40 percent by weight of NaOH.

The cell 10 preferably has been operated with caustic soda. Where caustic soda (NaOH) is used, water and the caustic soda enter through the anolyte distribution slots 18 and the solution flows along the high velocity flow path between the adjacent anode rods 12 and the anode inter-rod gaps 20 at the rear of the anolyte compartment toward the top of the cell 10. Thus, most of the anolyte fluid volume flow occurs between the anode rods 12 and within the hydrophilically treated separator mesh 24. The sodium ions migrate across the membrane, being produced as a result of the electrolysis reaction forming oxygen, water and sodium ions,

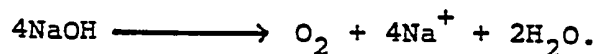

Depleted caustic passes out with oxygen and water through the anolyte collection slots 19.

The cathode backplate 28 is best seen in FIGURE 4, while the monolithic nature of the electrode that is machined from the solid stainless steel plate can be seen in FIGURE 5. Since the cell is bipolar, the cathode is on one side of the stainless steel plate on the cathode backplate 28 side, while the anode backplate 11 and the anode is on the opposing side. As seen best in FIGURE 4, the cathode backplate 28 has catholyte entry ports 35 on the opposing sides of the bottom portion of cathode backplate 28 that feed in catholyte into the catholyte distribution groove 32. Catholyte distribution groove 32, catholyte entry ports 35, and the machined catholyte transition slots 35' are positioned just above the corresponding anolyte distribution groove 15, anolyte ports 18 and the anolyte transition slots 18', but are on the opposite side of the solid stainless steel electrode plate.

A lower catholyte chamber 38 is positioned immediately above the catholyte distribution groove 32. The lower catholyte chamber 38 is separated from the upper catholyte chamber 39 by a generally horizontally positioned cathode flow barrier 30. Flow barrier 30 extends across the entire width of the catholyte chamber and protrudes outwardly from the plane of the catholyte backplate 28, as can be seen also in FIGURES 1 and 5. Cathode flow barrier 30 interrupts the vertical flow of catholyte fluid upwardly from the lower catholyte chamber 38 into the upper catholyte chamber 39, thereby causing the catholyte fluid to flow in a path shown by the arrows in FIGURE 1 that takes it twice through the cathode plate 26 enroute to the upper catholyte chamber 39. This flow path results in a cathode with a highly effective surface area, but requires the use of a very porous cathode plate that will permit at least 30% by volume of the catholyte fluid to flow through the porous cathode plate 26 rapidly to hold to a minimum the residence time of the catholyte in the cell. As will be described in greater detail hereafter, once the catholyte fluid has reached the upper catholyte chamber 39 it enters the catholyte collection groove 34 and exits the cell through the machined catholyte exit transition slots 36' and catholyte exit ports 36.

Weep holes 17, as seen in FIGURES 4 and 5, can be used in the cathode flow barrier 30 to permit hydrogen gas to rise from the lower catholyte chamber 38 to the upper catholyte chamber 39. Alternatively or concurrently weep holes 33, seen in FIGURE 5, can be used to permit the hydrogen gas to pass out of the interelectrode gap between the walls of the lower and

upper catholyte chambers 38 and 39 and the cathode plate 26 just below the cathode flow barrier 30 and then back through the cathode plate 26 opposite the catholyte collection groove 34.

The cathode plate 26 is held in place on the catholyte backplate 28 by a plurality of screws (not shown) that seat within the plurality of cathode support pedestals 31 within the lower and upper catholyte chambers 38 and 39.

The cathode plate 26 is a highly porous multilayer structure. It comprises a support layer formed of perforated stainless steel. This support layer forms the mounting base and protects the innermetal fiber felt layer that is formed of, for example, 15% dense, very fine 4 to 8 micron fibers and 15% dense 25 micron fibers laid on top of one another. A wire screen of, for example, 18 mesh with a .009 inch wire diameter is then placed atop the fiber felt to form a cathode that has a porosity of preferably between 80 and 85%. The cathode plate 26, thus, is a four layered sintered composite with all of the materials made of stainless steel, preferably 304 or 316 stainless steel, and in the appropriate sheet size. The highly effective surface area of cathode plate 26 is achieved by the use of low density metal felt formed from very fine elements.

A cathode gasket groove 29 is seen in FIGURE 4 extending about the periphery of the cathode backplate 28. Although not shown, a 3/8" round EPDM, ethylene-propylene-diene monomer, gasket is used to seat within the cathode gasket groove 29 to effect fluid-tight sealing.

Reduction occurs at the cathode in the cell 10 by the electrolysis of a buffered aqueous solution of an alkali metal bisulfite. A typical reaction is as follows:

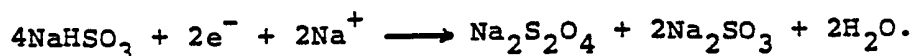

Depleted caustic and sulfur dioxide are mixed to form NaHSO_3 that is fed into the catholyte distribution groove 32 via the catholyte entrance ports 35 and the catholyte transition slots 35'. This catholyte liquid then rises vertically upwardly until it passes out through the cathode plate 26, as best seen in FIGURES 5 or 1. The cathode flow barrier 30 acts as a block to the straight vertical flow of the catholyte fluid upwardly from the lower catholyte chamber 38 into the upper catholyte chamber 39. There is an approximately 1/8" interelectrode cathode gap between the walls of the lower and upper catholyte chambers 38 and 39 and the cathode plate 26 that is seated on the cathode support pedestals 31. The catholyte fluid then passes through the cathode plate 26 and continues flowing upwardly through the cathode-membrane gap until it passes the cathode flow barrier 30. At this point the catholyte fluid passes back through the highly porous cathode plate 26 into the upper catholyte chamber 39 and then into the catholyte collection groove 34. The cell product solution containing $\text{Na}_2\text{S}_2\text{O}_4$ (dithionite) exits the cell 10 through the catholyte exit transition slots 36' and the catholyte exit ports 36.

A buffer solution containing from about 40 to about 80 gpl of bisulfite is utilized with the catholyte because of sodium thiosulfate formation resulting from

the reduction and decomposition of hydrosulfite (dithionite) and the pH change of the catholyte as bisulfite is consumed and sulfite is formed according to the reaction

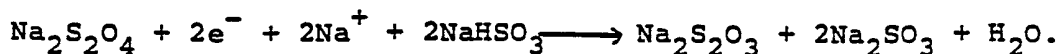

The use of a monolithic cell body, that is a bipolar cell body or backplate formed from a single plate of stainless steel machined to form an anode backplate on one side and a cathode backplate on the opposing side, provides several significant inherent operating advantages. Initially, there is no shifting or dimensional instability because of the joining of two separate pieces of material to form the electrode. There is a reduction in the number of actual cell components from the use of a single machined plate. Lastly, and perhaps most significantly, there is the elimination of electrical loss from the contact between two separate anode and cathode elements that would otherwise have some spacing and sizing differences. This particular configuration contributes to lower cell electrical energy consumption.

The hydraulic pressure in cell 10 is established so that the membrane 25 is kept pressed against the separator means 21 and off of the cathode plate 26. Keeping the membrane 25 so positioned also permits the flow path through the cathode plate to be accomplished. The cathode flow barrier 30 further contributes to the hydraulics of the cell 10 by achieving a uniform pressure across the entire height of the cathode due to the flow inversion characteristics achieved by the multiple flow paths through the cathode plate 26.

The electrolytic cell 10 is operated at current densities which are sufficient to produce solutions of alkali metal hydrosulfites having the concentrations desired. For example, where sodium hydrosulfite is produced for commercial sale, the solutions contain from about 120 to about 160 grams per liter. However, since the alkali metal hydrosulfite solutions sold commercially are usually diluted before use, these dilute aqueous solutions can also be produced directly by the process.

Current densities of at least 0.5 kiloamperes per square meter are employed. Preferably the current density is in the range of from about 1.0 to about 4.5, and more preferably at from about 2.0 to about 3.0 kiloamperes per square meter. At these high current densities, the electrolytic cell 10 operates to produce the required volume of high purity alkali metal hydrosulfite solution which can be employed commercially without further concentration or purification.

The electrolytic membrane cell 10 employs a cation exchange membrane between the anode and the cathode compartments which prevents any substantial migration of sulfur-containing ions from the cathode compartment to the anode compartment. A wide variety of cation exchange membranes can be employed containing a variety of polymer resins and functional groups, provided the membranes possess the requisite sulfur ion selectivity to prevent the deposition of sulfur inside membranes. Such deposition can blind the membranes, the result of sulfur species diffusing through the membranes and then being oxidized to create acid within the membranes that causes hydrosulfite and thiosulfate to decompose to sulfur in acidic conditions. This selectivity can be verified by analyzing the anolyte for sulfate ions.

Suitable cation exchange membranes are those which are inert, flexible, and substantially impervious to the hydrodynamic flow of the electrolyte and the passage of gas products produced in the cell. Cation exchange membranes are well-known to contain fixed anionic groups that permit intrusion and exchange of cations, and exclude anions, from an external source. Generally the resinous membrane has as a matrix or a cross-linked polymer to which are attached charged radicals, such as $-\text{SO}_3^-$, $-\text{COO}^-$, $-\text{PO}_3^-$, $-\text{HPO}_2^-$, $-\text{AsO}_3^-$, and $-\text{SeO}_3^-$ and mixtures thereof. The resins which can be used to produce the membranes include, for example, fluorocarbons, vinyl compounds, polyolefins, and copolymers thereof. Preferred are cation exchange membranes such as those comprised of fluorocarbon polymers having a plurality of pendant sulfonic acid groups or carboxylic acid groups or mixtures of sulfonic acid groups and carboxylic acid groups. The terms "sulfonic acid group" and "carboxylic acid groups" are meant to include salts of sulfonic acid or salts of carboxylic acid groups by processes such as hydrolysis. Suitable cation exchange membranes are sold commercially by E. I. DuPont de Nemours & Co., Inc. under the trademark "Nafion", by the Asahi Glass Company under the trademark "Flemion", by the Asahi Chemical Company under the trademark "Aciplex". Perfluorinated sulfonic acid membranes are also available from the Dow Chemical Company.

The membrane 25 is positioned between the anode and the cathode and is separated from the cathode by a cathode-membrane gap which is wide enough to permit the catholyte to flow between the cathode plate 26 and the membrane 25 from the lower catholyte chamber 38 to the upper catholyte chamber 39 and to prevent gas

blinding, but not wide enough to substantially increase electrical resistance. Depending on the form of cathode plate 26 used, this cathode-membrane gap is a distance of from about 0.05 to about 10, and preferably from about 1 to about 4 millimeters. The cathode-membrane gap can be maintained by hydraulic pressure or mechanical means. This design and the catholyte flow path permits almost all of the catholyte liquid to contact the active area of the cathode. Further, with this design the majority of the electrolytic reaction occurs in the cathode area nearest the anode.

Suitable porous cathode plates 26 used in the cell 10 have at least one layer with a total surface area to volume ratio of greater than 100 cm^2 per cm^3 , preferably 250 cm^2 per cm^3 , and more preferably greater than 500 cm^2 per cm^3 . These structures have a porosity of at least 60 percent and preferably from about 70 percent to about 90 percent, where porosity is the percentage of void volume. The ratio of total surface area to the projected surface area of the porous cathode plate 26, where the projected surface area is the area of the face of the cathode plate 26, is at least about 30:1 and preferably at least from about 50:1; for example, from about 80:1 to about 100:1.

Current is conducted into the cell 10 through anode and cathode current conductor plates (not shown). Plates of copper the size of the electrodes are placed against the end cathode and end anode in each cell 10. Electrical connections are made directly to these copper plates. An insulator plate made, for example, of polyvinyl chloride or other suitable plastic, and a compression plate (both not shown) made for example, of

stainless steel or steel, are placed against each end of the cell 10 before it is assembled to form a sandwich around the desired number of electrodes that are positioned therebetween.

The cell of the invention could also be designed as monopolar, requiring that both sides of each stainless steel plate be identically machined and that half electrodes be used as the end electrodes in the assembled cell. The current conductors in the monopolar design would then be standard copper electrical terminals for each electrode.

Additionally the cell of the present invention could be utilized in electrochemical reactions other than the production of hydrosulfite. Typical is the production of organic products by electrochemistry, such as the electrochemical transformations of pyridines through oxidation or reduction reactions in a cation-exchange membrane divided cell of the above design.

Employing the novel design of the cell 10, concentrated alkali metal hydrosulfite solutions are produced having low concentrations of alkali metal thiosulfates as an impurity in electrolytic membrane cells operating at high current densities, substantially reduced cell voltages, and high current efficiencies.

Example 1

A cell of the type shown in FIGURES 1-5 was assembled from three stainless steel plates which were mounted on a rack to form two anode/cathode pairs whose active electrode area was about 0.172 square meters each. The plates formed two half electrodes, one a cathode and the other an anode, sandwiched about a bipolar electrode with opposing anode and cathode faces. The outside dimensions of the electrode plates were about 17 inches wide by about 18.5 inches high and about 1.0 inches thick.

The anodes were comprised of about forty-seven (47) 1/8 inch diameter nickel 200 rods welded onto the anode backplate, as shown generally in FIGURE 2, with approximately 1/16 inch separation between the rods. The anolyte collection and distribution grooves were about 1.25 inches wide and about 0.61 inches deep.

The cathode plate was formed from a four layered sheet cut to size. The first layer was a support layer formed of perforated stainless steel 0.036 inches thick with 1/16 inch holes on 1/8 inch 60° staggered centers having a 23% open area. The second layer was a 0.62 pounds per square foot layer of 304 stainless steel fibers about 25 microns in diameter. The third layer was a 0.12 pounds per square foot layer of 304 stainless steel fibers about 8 microns in diameter. The fourth layer was an 18" x 18" mesh of about 0.009 inch diameter wire cloth. These layers were compressed together and bonded by sintering in a hydrogen atmosphere to form a single sheet with a thickness of about 0.155 inches. The cathode sheet was cut to form a cathode plate of about 18.5 inches by about 17 inches.

The cathode plate was mounted onto the stainless steel cathode backplate using 20 screws of about 1/8 inch diameter that seated into the cathode support pedestals within the catholyte chambers. A small coating of appropriate electrical joint compound was used on the threads of the screws and a silicon cement was placed over the head of each screw to prevent the screw from becoming an active part of the cathode assembly.

Six (06) 1/6 inch diameter holes were drilled in the cathode plate to permit gas bubbles trapped within the cell to escape. Three of the holes were drilled near the top of the cell opposite the catholyte collection groove and three just below the cathode flow barrier.

Separator means were formed from polypropylene mesh treated with a coating of titanium dioxide. The separators were mounted in 1/16 inch thick separator frames cut to fit just inside the gasket groove in the cell.

Gasket grooves about 0.375 inches wide and about 0.187 inches deep were machined into both the anode and cathode backplates. On the anode side of the cell about a 0.375 inch square gasket was used with about a 0.5 inch wide strip of about 0.060 thick GORE-TEX® gasket tape placed on top. In the cathode gasket groove a rubber O-ring of about a 0.378 inch diameter was used. The cell was assembled using a portable hydraulic assembly system described in U.S. Patent No. 4,430,179 that compressed the cell together so that approximately a 1/8 inch gap between the anode and the cathode plates remained. The cell was then secured by retaining nuts.

TABLE I

<u>Day</u>	<u>Na₂S₂O₄ (gpl)</u>	<u>Na₂S₂O₃ (gpl)</u>	<u>Na₂SO₃ (gpl)</u>	<u>NaHSO₃ (gpl)</u>	<u>Average Current Density (KA/m²)</u>	<u>Current Efficiency (%)</u>	<u>Average Voltage Per Bipolar Electrode (volts)</u>
5	128.60	1.01	11.55	46.60	2.03	97.5	2.76
6	126.80	1.01	12.10	50.70	2.06	96.0	2.75
7	126.00	1.51	8.80	46.70	2.03	97.0	2.73
8	127.20	0.94	8.30	47.40	2.05	97.0	2.95

25

Example 2

A cell similar to the design of Example 1 was assembled utilizing nine bipolar electrode plates and two half electrode plates, one an anode and one a cathode, having approximately a 0.051 square meter active electrode area for each. The same type of cathode plate and anode rods were used as in Example 1, except that the anode and cathode backplates were about 13.5 inches by about 13.5 inches and about 1.188 inches thick. A perfluorinated sulfonic acid membrane, with a thickness of about 2 mils and an equivalent weight of about 1000 (grams/gram-mole equivalent exchange capacity), available from the assignee of U. S. Patent No. 4,470,888 was used.

The separator means were a mesh made from titanium dioxide filled polyethylene, the mesh being about 0.07 inch thick with approximately 0.38 inch openings and about 60% open area. The separator was treated with a mixture of chromic and sulfuric acids, available from Fisher Scientific under the name CHROMERGE to obtain the necessary hydrophilic surface. The separator mesh was mounted on a 1/8 inch separator frame that extended about 1/4 inch beyond the edge of the cell.

The cell was sealed using about 0.290 inch diameter O-rings in both the anode and cathode backplate gasket grooves. A strip of about 0.875 inch GORE-TEX tape was used between the separator frame and the membrane.

The cell operated with a total catholyte flow rate of 13 gpm and a total anolyte flow rate of 6 gpm. The anolyte had continuously added to it 93 grams per minute of 35% sodium hydroxide solution. Excess anolyte containing about 15% sodium hydroxide was continuously purged and added to the catholyte circulation

system. Additionally, about 320 milliliters per minute of deionized water was added to the catholyte, while sulfur dioxide was continuously added to the catholyte to maintain a pH of between about 5.4 to about 5.8 and a sulfite to bisulfite molar ratio of between about 1:3 to about 1:8.

The cell was operated at a temperature of about 25°C with a total catholyte flow rate of about 13 gpm and a total anolyte flow rate of about 6 gpm. The cell was operated continuously for over 30 days without significant change in voltage coefficient or product composition.

Product catholyte was continuously withdrawn from the cell at a rate of about 350 milliliters per minute and was analyzed periodically during each day. The product catholyte reflected in the following Table II was analyzed from samples taken at the same time each day. These data are representative of the operation of the cell during 4 days of operation under optimized conditions. The catholyte was analyzed for sodium hydrosulfite, sodium thiosulfate, sodium sulfite and sodium bisulfite content.

28-

TABLE II

<u>Day</u>	<u>Na₂S₂O₄ (gpl)</u>	<u>Na₂S₂O₃ (gpl)</u>	<u>Na₂SO₃ (gpl)</u>	<u>NaHSO₃ (gpl)</u>	<u>Average Current Density (KA/m²)</u>	<u>Current Efficiency (%)</u>	<u>Average Voltage Per Bipolar Electrode (volts)</u>
7	141.5	4.46	9.58	56.50	1.92	98.25	2.33
8	140.1	4.06	9.58	57.40	1.92	96.20	2.28
10	138.4	5.18	9.07	51.50	1.92	95.00	2.32
13	141.4	4.50	7.06	49.80	1.92	93.20	2.38

While the preferred structure in which the principles of the present invention have been incorporated as shown and described above, it is to be understood that the invention is not to be limited to the particular details thus presented, but, in fact, widely different means may be employed in the practice of the broader aspects of this invention. For example, while the anode backplate is shown and described as employing round wire rods on its surface, flat rectangular bars or other appropriate geometrically shaped structures, such as triangular, pentagonal, hexagonal, octagonal, etc. could be equally well utilized. Additionally the separator mesh could be exposed to hydrophilic containing additives or such additives could be in the electrolyte. The separator mesh could also be assembled in the cell between the membrane and the cathode plate, in conjunction with the hydraulic pressure being changed so that the membrane is forced off of the anode rods and against the separator mesh.

CLAIMS

1 . An electrolytic cell having a top and a bottom, with provision for an anolyte and a catholyte to flow therethrough, comprising in combination

(a) a plurality of adjacently positioned bipolar cell bodies each providing an anode backplate and a cathode backplate;

(b) a plurality of porous cathode plates each having a first surface and an opposite second surface, the opposite second surface being adjacent the cathode backplate;

(c) a cation exchange membrane between each pair of adjacently positioned anode surfaces and cathode plate first surfaces; and

(d) separator means intermediate each anode surface and membrane to prevent the membrane from touching the adjacent anode surface, the separator means further having a frame portion about its exterior and a hydrophilically treated mesh portion interiorly connected thereto adjacent each anode surface and membrane.

2. The cell according to Claim 1 wherein the mesh portion of the separator means is coated with titanium dioxide.

3. The cell according to Claim 2 wherein the mesh portion of the separator is titanium dioxide filled polyethylene.

4. The cell according to any one of Claims 1-3 wherein the anode surface further comprises a plurality of vertically positioned substantially parallel flow directing means having a gap between each adjacent pair to thereby form a plurality of flow channels for the anolyte between the top and the bottom of the cell.

5. The cell according to Claim 4 wherein the plurality of vertically positioned substantially parallel flow directing means are rods.

6. The cell according to Claim 4 or 5 wherein the plurality of vertically positioned substantially parallel flow directing means are of nickel.

7. The cell according to any one of Claims 1-6 wherein each bipolar cell body is formed of stainless steel.

8. The cell according to any one of Claims 1-7 wherein the catholyte is present and is a buffered aqueous solution of sodium bisulfite.

9. The cell according to any one of Claims 1-8 wherein the anolyte is present and comprises a mixture of sodium hydroxide and deionized water.

10. The cell according to any one of the preceding claims, wherein said porous cathode plate is multilayered, the second surface thereof being a support layer of perforated material having a second layer of fibers atop of it and a third layer of fibers less dense than the second layer atop the second layer and forming at least a portion of the first surface that is adjacent the membrane.

11. The cell according to claim 10, wherein the second layer of fibers has a density of about 0.62 pounds per square foot and the fibers have an individual diameter of about 25 microns.

12. The cell according to claim 10 or 11, wherein the third layer of fibers has a density of about 0.12 pounds per square inch and the fibers have an individual diameter of about 8 microns.

13. The cell according to any one of claims 10-12, wherein the porous multilayered cathode plate further comprises a fourth layer of meshed wire cloth atop of the third layer of fibers.

14. The cell according to any one of claims 10-13, wherein the support layer of perforated material has about 23 percent open area.

15. The cell according to any one of claims 10-14, wherein the fibers of the second layer and the third layer are fibers of stainless steel.

16. An electrolytic cell having a top and a bottom with provision for an anolyte and a catholyte to flow therethrough, comprising in combination:

- (a) an anode;
- (b) a porous cathode plate having a first surface and an opposite second surface;
- (c) a cation exchange membrane between the anode and said cathode plate first surface; and
- (d) separator means between the anode and the membrane to prevent the membrane from touching the anode, said separator means having a frame portion about its exterior and a hydrophilically treated mesh portion interiorly connected thereto adjacent the anode and the membrane.

17. The cell according to claim 16 wherein the mesh portion of the separator means is coated with titanium dioxide.

18. The cell according to claim 16 wherein the mesh portion of the separator is titanium dioxide filled polyethylene.