



US 20040154889A1

(19) **United States**

(12) **Patent Application Publication**
Gifford et al.

(10) **Pub. No.: US 2004/0154889 A1**

(43) **Pub. Date: Aug. 12, 2004**

(54) **CENTER OPENING UPRIGHT LUGGAGE CASE WITH SIX WHEELS**

(52) **U.S. Cl.** 190/18 A; 190/18 R; 190/109; 280/37; 280/655

(76) Inventors: **Jason M Gifford**, Cranston, RI (US);
William L King, Denver, CO (US);
Kenzo Yoneno, Providence, RI (US)

(57) **ABSTRACT**

Correspondence Address:
SAMSONITE CORPORATION
11200 EAST 45TH AVENUE
DENVER, CO 80239 (US)

(21) Appl. No.: **10/476,291**

(22) PCT Filed: **Mar. 3, 2003**

(86) PCT No.: **PCT/US03/06566**

Related U.S. Application Data

(62) Division of application No. 60/361,943, filed on Mar. 5, 2002.

Publication Classification

(51) **Int. Cl.⁷** **A45C 13/00; A45C 13/26**

A wheeled luggage case (30) including a main body having a top surface (44), a bottom surface (42), a front wall (34), a rear wall (36), a first side wall (38), and a second side wall (40); a handle (46) mounted adjacent to the rear wall; a first wheel (74) and second wheel connected with a rear edge (76) defined by an intersection of the rear wall and bottom surface; a first rearward side wheel (74) and first frontward side wheel (74) connected with a first side edge (82) defined by an intersection of the first side wall and bottom surface; and wherein a first distance from the first side edge to a first contact point of the first frontward side wheel is greater than a second distance from the first side edge to a second contact point of the first rearward side wheel to aid in stabilizing the luggage case when wheeled on a rearward side wheel and corresponding frontward wheel.

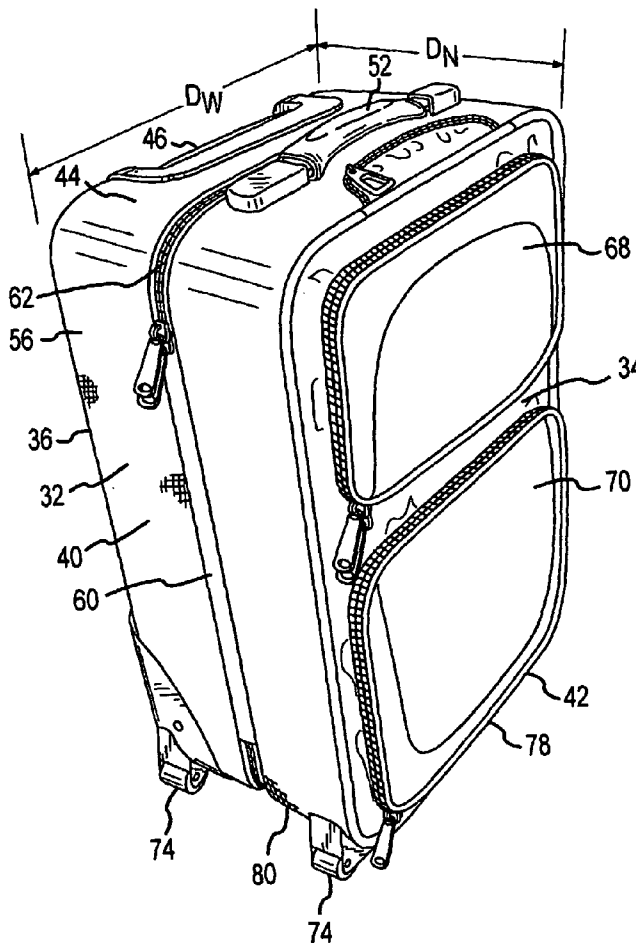

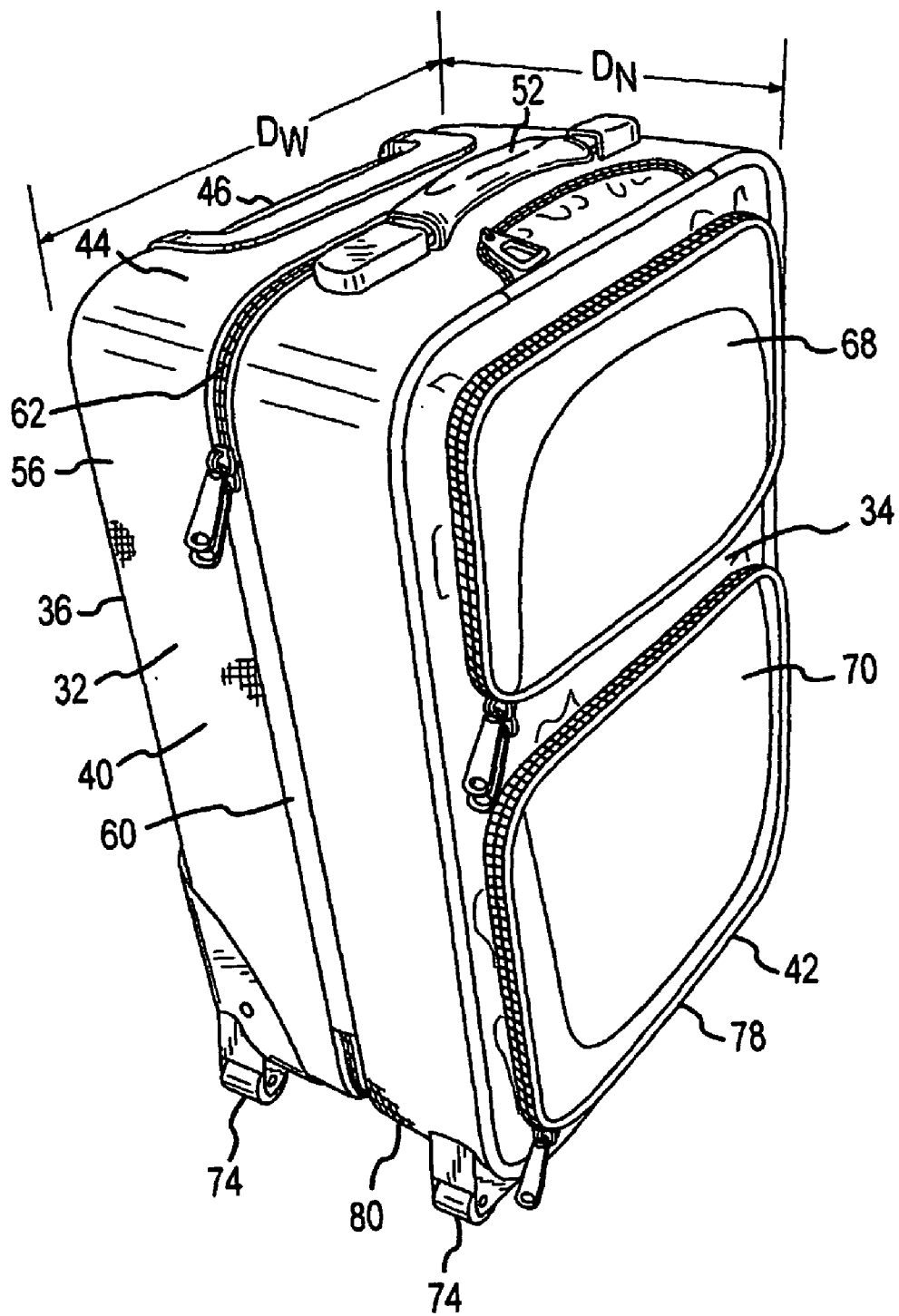

FIG. 1

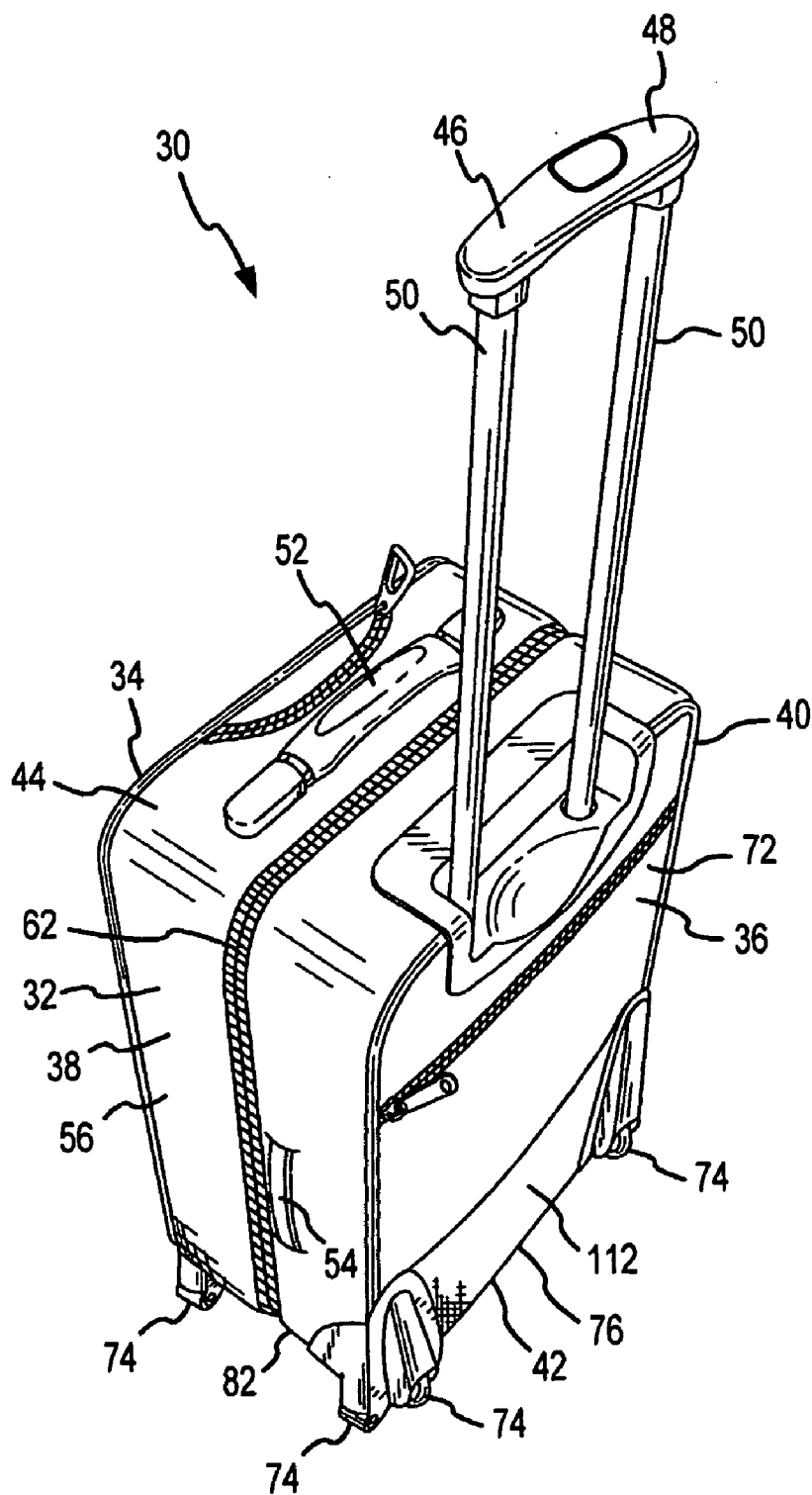

FIG. 2

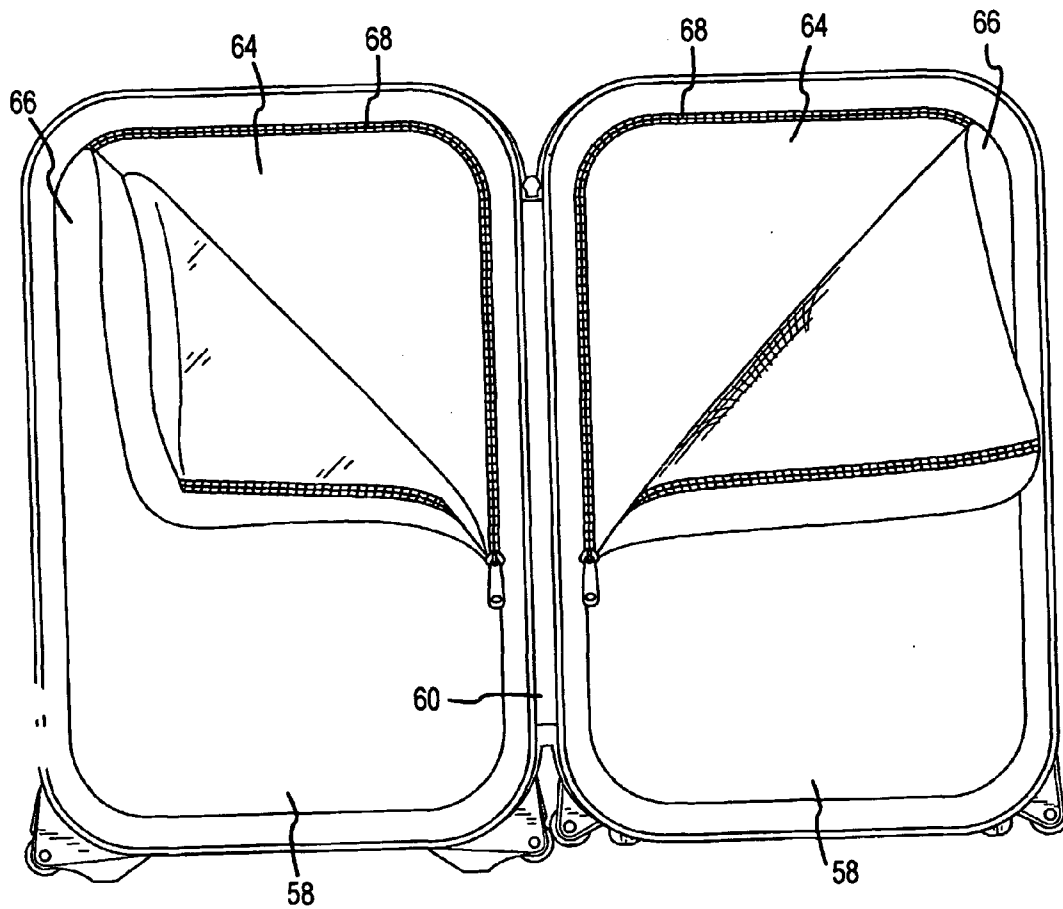

FIG.3

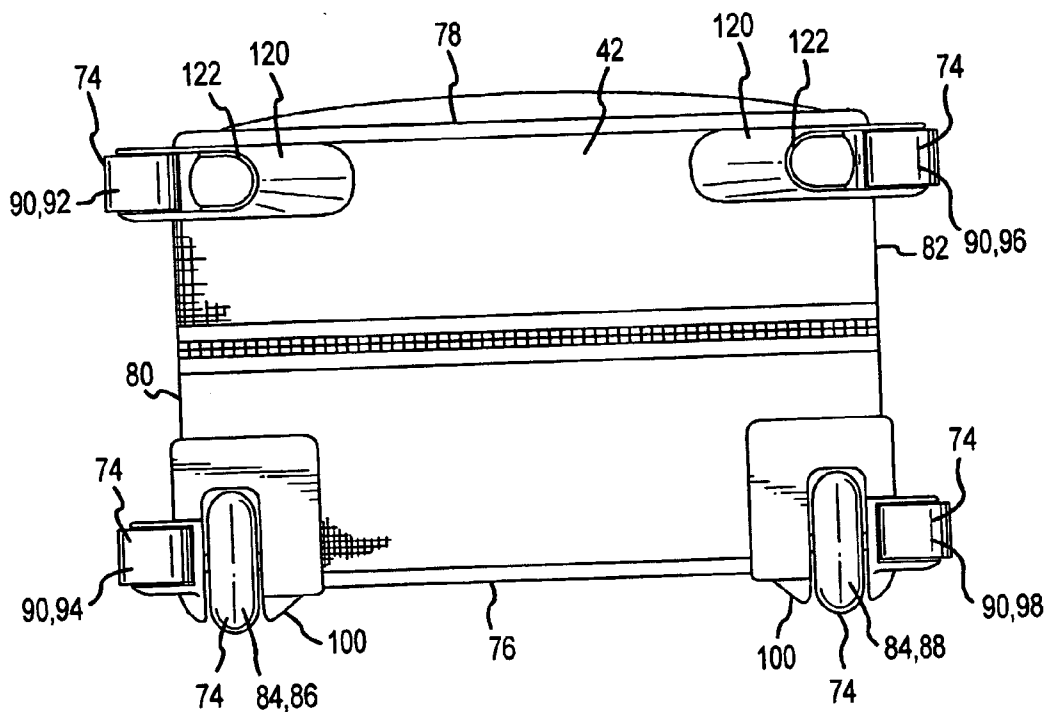

FIG.4

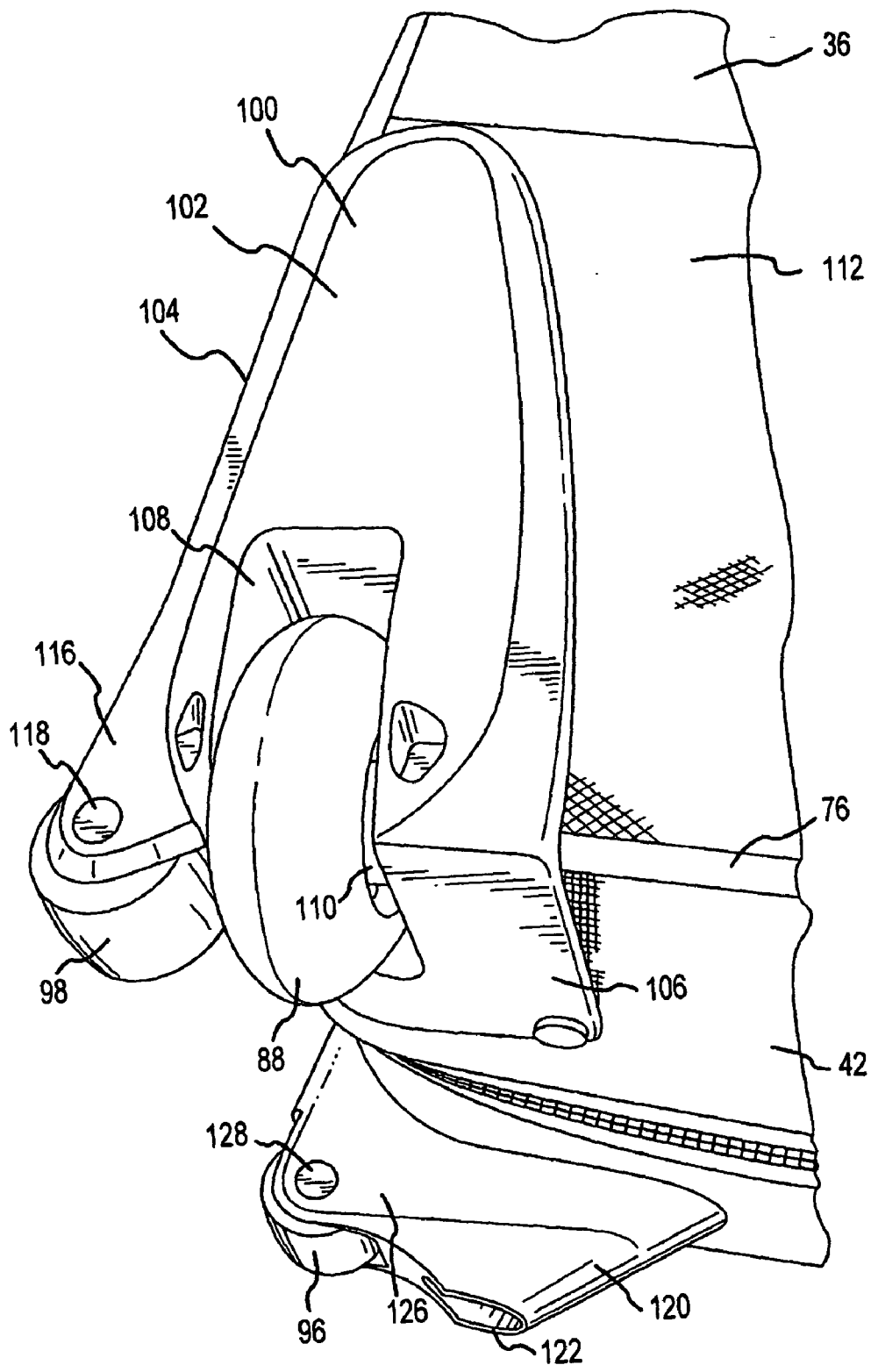

FIG.5

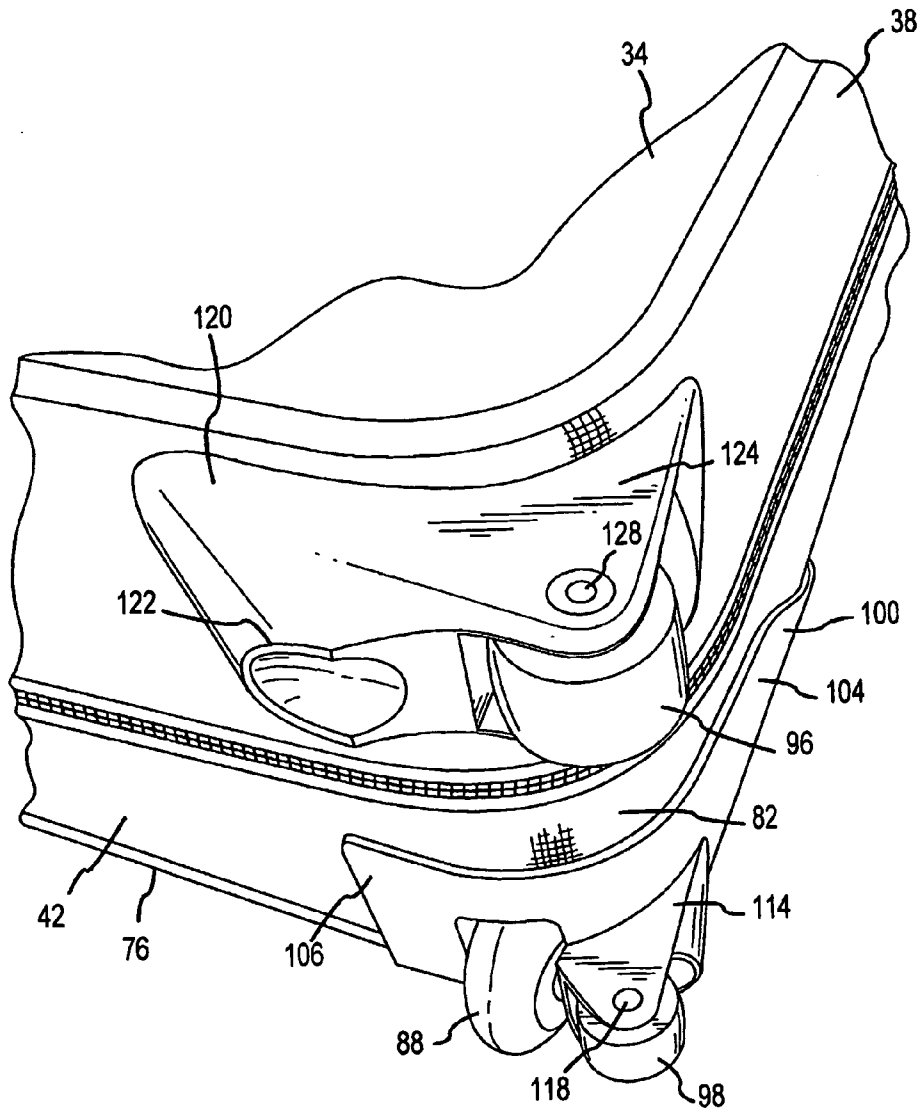

FIG. 6

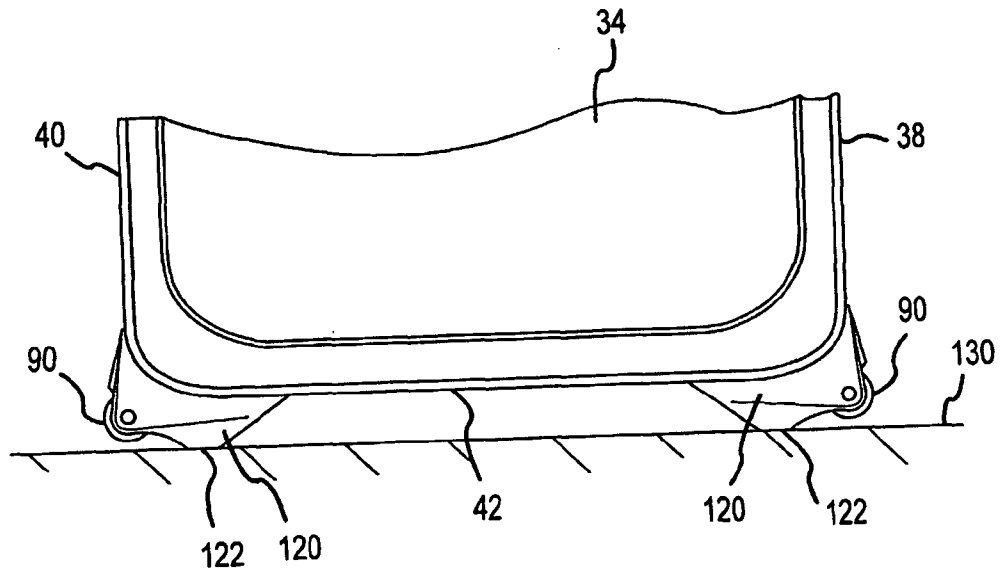

FIG.7

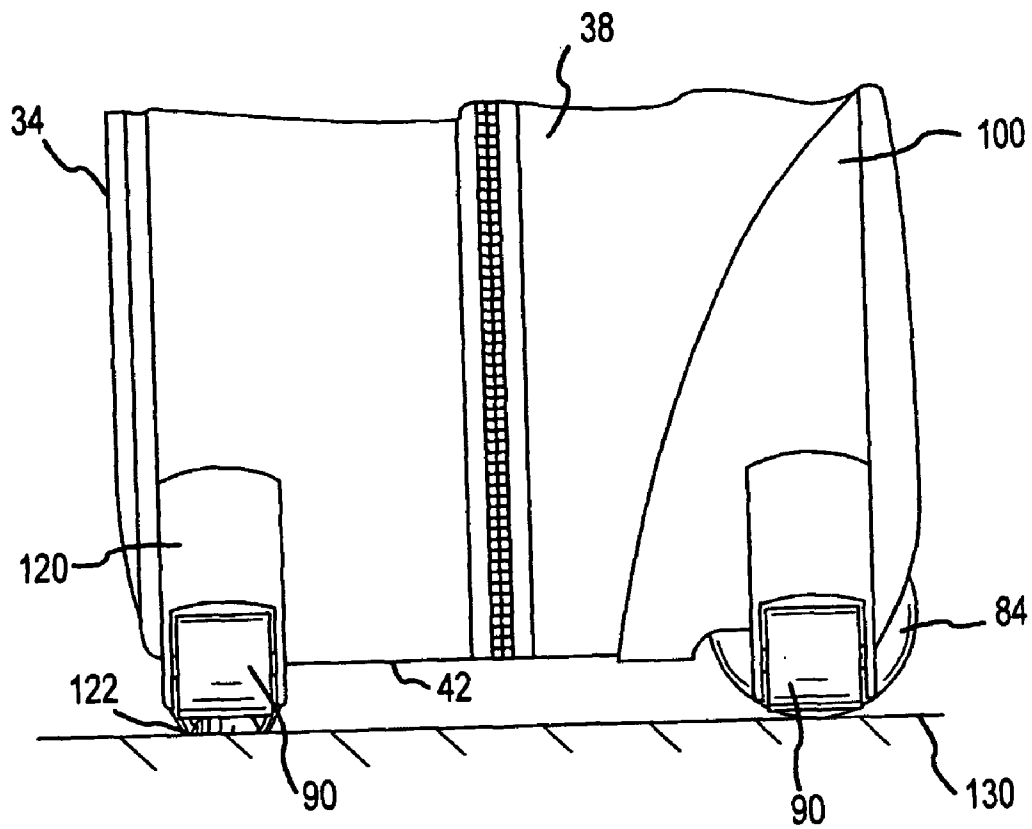

FIG. 8

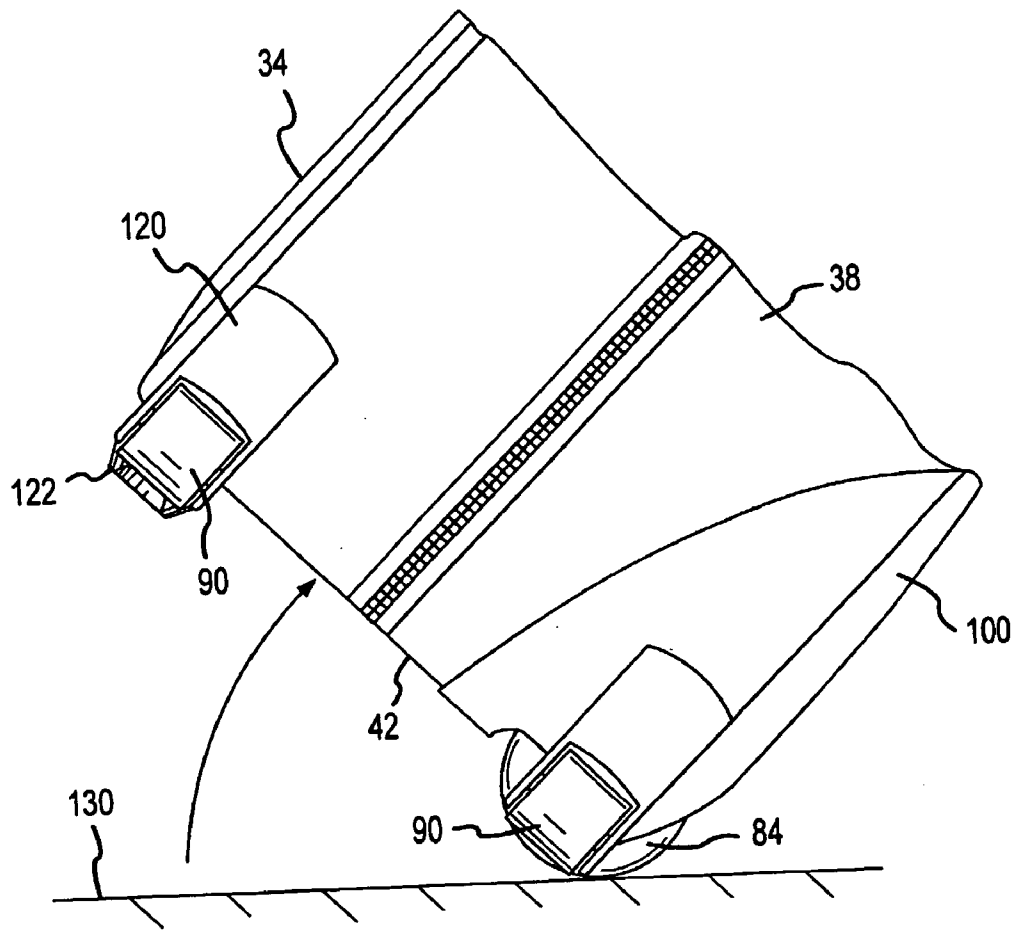

FIG. 9

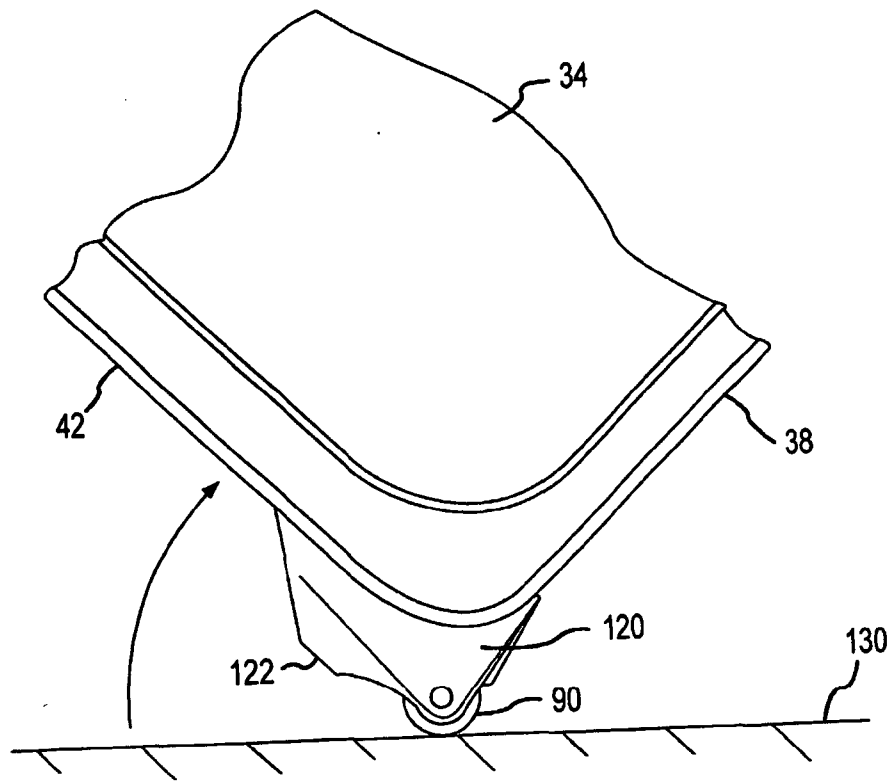

FIG.10

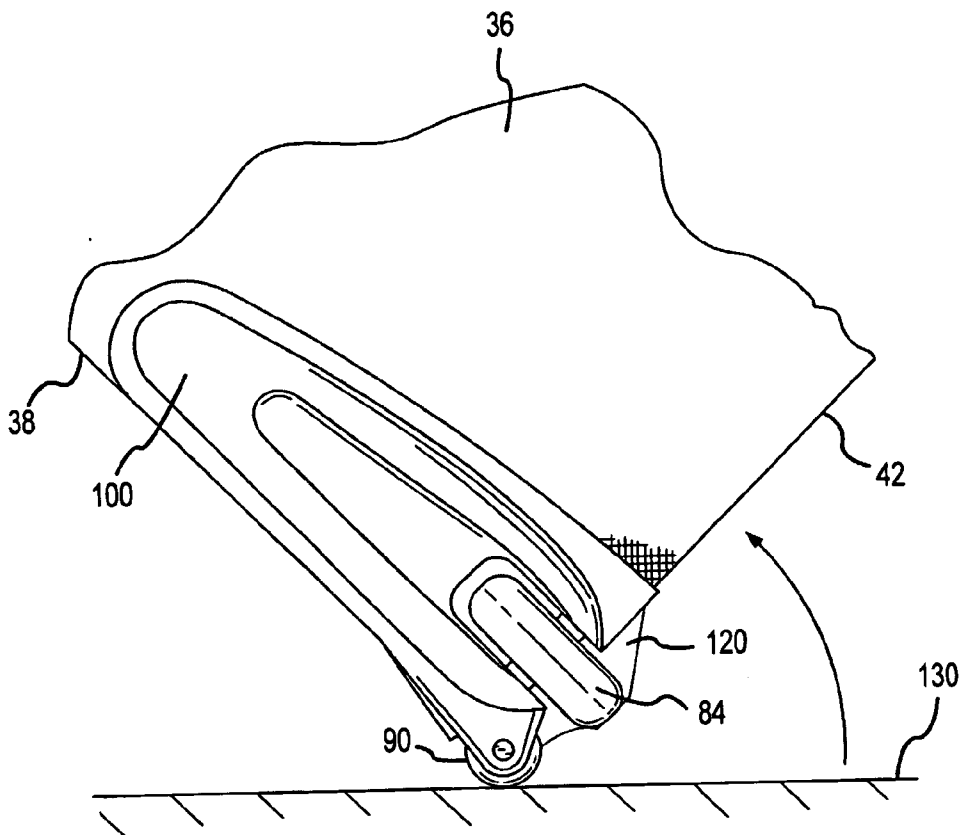

FIG.11

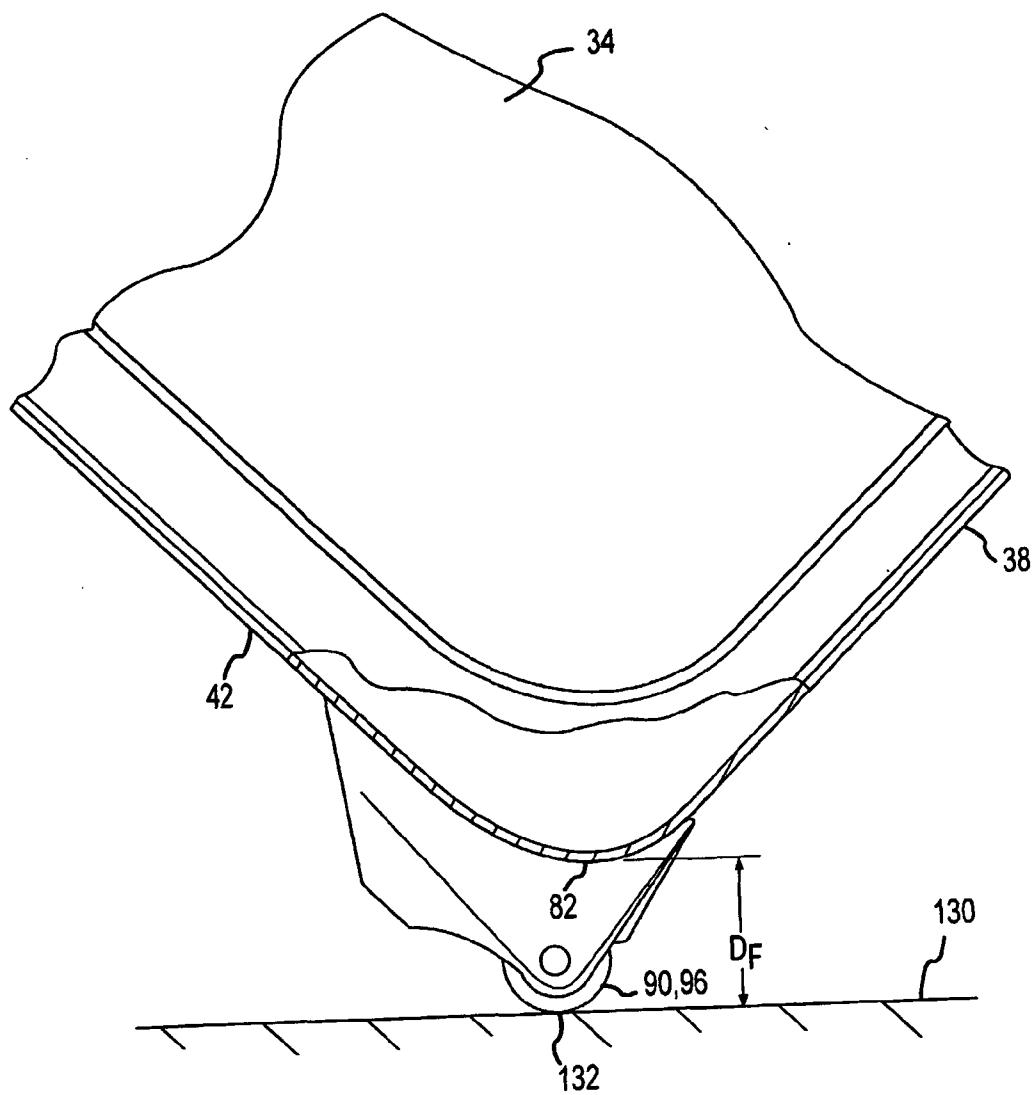

FIG.12

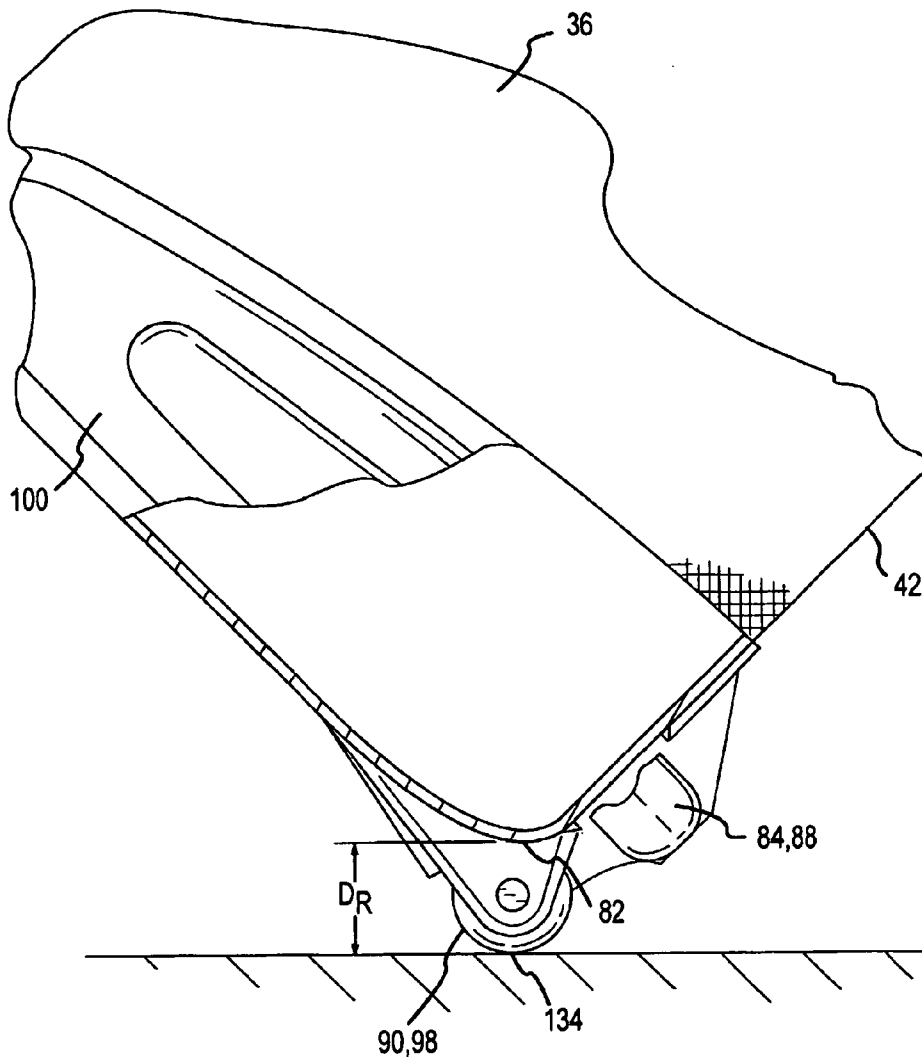

FIG. 13

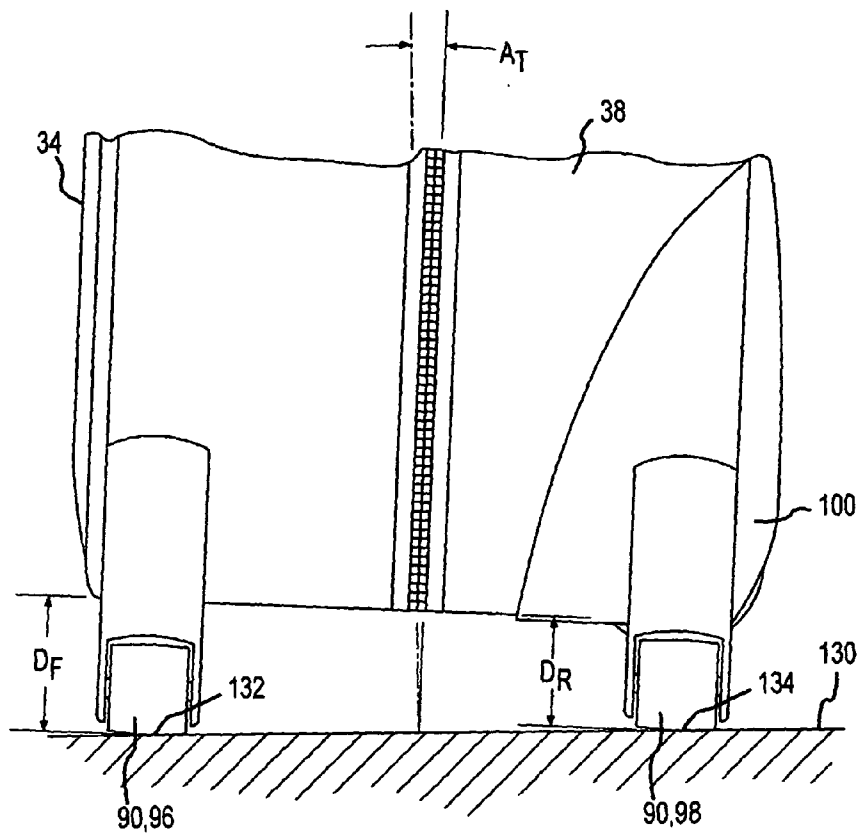

FIG. 14

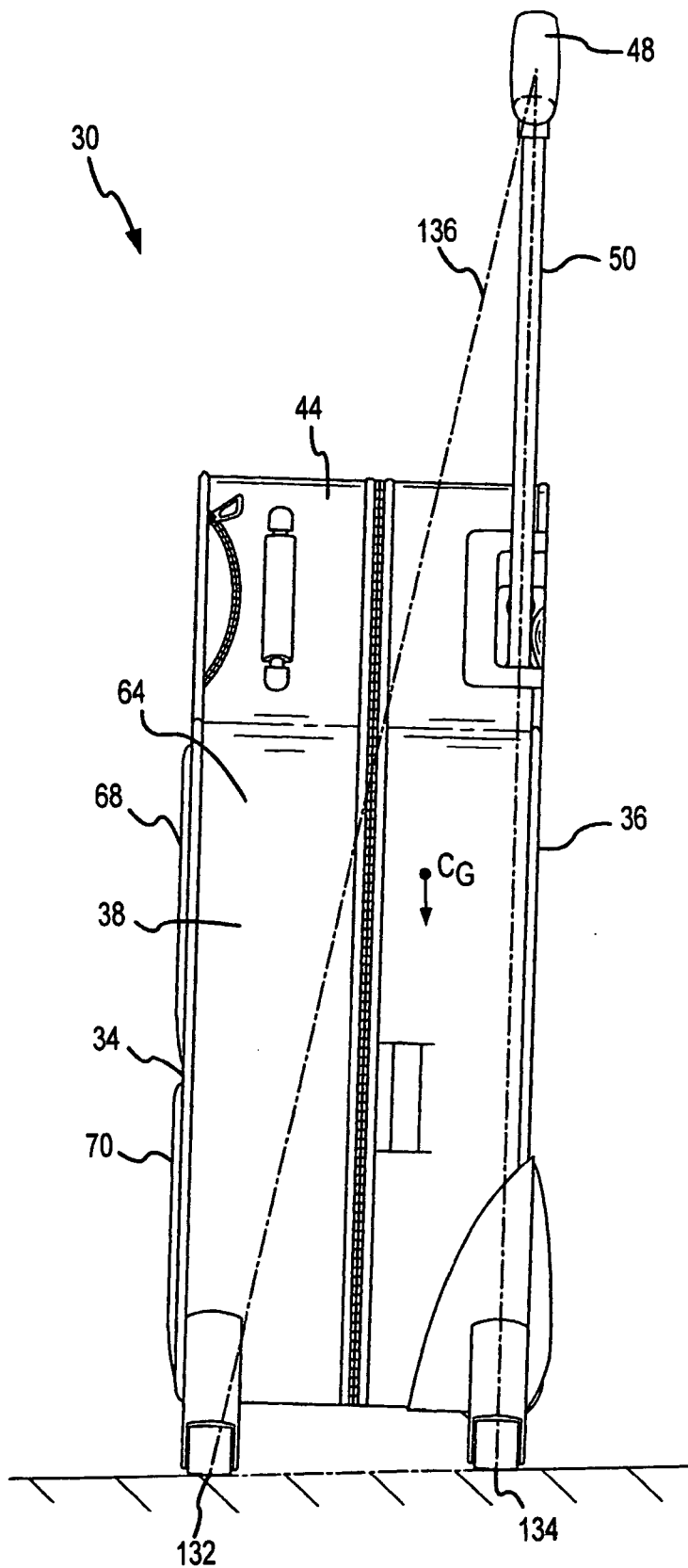

FIG. 15

CENTER OPENING UPRIGHT LUGGAGE CASE WITH SIX WHEELS

CROSS-REFERENCE TO RELATED APPLICATIONS

[0001] This application claims the benefit of U.S. Provisional Application No. 60/361,943, filed on Mar. 5, 2002. The above-identified provisional application is hereby incorporated by reference as if fully disclosed herein.

FIELD OF THE INVENTION

[0002] This invention relates to luggage cases, and more specifically relates to upright luggage cases with wheel designs allowing for more maneuverability and stability.

BACKGROUND OF THE INVENTION

[0003] Luggage cases are well-known in the art. A popular luggage case design is shaped generally like a rectangular box having four sides, a top, and a bottom. In many luggage case designs, two of the four sides (i.e., front and back sides) are wider than the other two sides (i.e., left and right sides). The width of the wider sides define a wide dimension, and the width of the narrower sides define a narrow dimension. In the past, wheels have been added to the bottoms of luggage cases to allow a user to move a heavy luggage case more easily from one location to another without having to carry it. As wheeled luggage cases have become more popular, further attempts have been made to make the luggage cases more maneuverable.

[0004] Many wheeled luggage case designs currently on the market allow a luggage case to be easily rolled in a direction substantially parallel to its narrow dimension (i.e., frontward or backward), but may not allow it to be rolled 90° in another direction that is substantially parallel to its wider dimension (i.e., sideways), such as when pulling the luggage case down a narrow aisle or the like. For example, the luggage case disclosed in U.S. Pat. No. 5,253,739 ('739) has two wheels mounted in an edge defined by the intersection of a bottom surface and a narrow vertical side of the luggage case. The luggage case in the '739 patent also utilizes an extendable handle mounted in and along the axis of symmetry and over the wheels. The design shown in the '739 patent allows the luggage case to be tipped and pulled in a direction substantially parallel to its wide dimension while supported by the two wheels, which makes it easier to maneuver the luggage case down narrow passages or aisles. However, the luggage case disclosed in the '739 patent does not allow it to also be pulled in a direction substantially parallel to its narrow dimension.

[0005] One attempt to provide more maneuverability of wheeled luggage in various directions is shown in U.S. Pat. No. 5,197,578 ('578). The luggage case shown in the '578 patent has four wheels on its bottom surface. Three of the four wheels are caster wheels that can turn 360°. The fourth wheel is a fixed axis wheel with its center fixed on an axis substantially parallel to the wide dimension of the luggage case. The design shown in the '578 patent allows the luggage case to be tipped and pulled in a direction substantially parallel to its narrow dimension while being supported on two caster wheels. The luggage case also rolls in a direction substantially parallel to its wider dimension when supported on all four wheels, allowing it to more easily be rolled down narrow passages or aisles.

[0006] Unlike the '578 patent and the '739 patent, U.S. Pat. No. 5,564,538 ('538) discloses a luggage case that can be tipped and rolled in a direction substantially parallel to its wider dimension and in a direction substantially parallel to its narrow dimension. The '538 patent discloses a luggage case with an extendable handle, front and back sides, narrower left and right sides, a top, a bottom, and six wheels. A first pair of wheels are mounted on a first edge defined by the intersection of a back side and the bottom of the luggage case. Therefore, the luggage case can be tipped and pulled in a rearward direction while being supported on the first pair of wheels. A second pair of wheels are mounted on a second edge defined by the intersection of a right side and the bottom of the luggage case. A third pair of wheels are also mounted on a third edge defined by the intersection of a left side and the bottom of the luggage case. Therefore, the luggage case can also be tipped and pulled in either direction substantially parallel to its wide dimension while supported on either the second or third pair of wheels.

[0007] When the luggage case disclosed in the '538 patent is tipped and pulled while being supported by either the second or third pair of wheels, it may be susceptible to tipping to one side or the other depending upon the location of the center of gravity of the luggage case and the relative placement of the handle. Generally, the center of gravity is located in the geometric center of the luggage case, but the location may change depending upon how a user stores goods in the luggage case. For example, a user may store heavier items toward the front of the luggage case, which may cause the center of gravity to shift toward the front of the luggage case, and cause it to be somewhat unstable when rolling sideways. To overcome this problem, one embodiment disclosed in the '538 patent places an extendable handle in the middle of the luggage case. Although placing the handle in the middle of the luggage case allows a user to more easily resist tipping, this is not a practical solution since most handle mechanisms are designed to be mounted adjacent to and preferably on one of the broad outside wall structures of an upright case. U.S. Pat. No. 5,890,570 patent discloses a second embodiment with a handle mechanism mounted adjacent to the rear side of the luggage case. However, the handle mechanism disclosed in the second embodiment also has a rotatable handle portion. When pulling the luggage in a direction substantially parallel to its wide dimension (i.e., sideways), the user rotates the handle portion 90° such that it is centered over the top of the luggage case to help keep it balanced. However, there are drawbacks to having a rotatable handle portion. For example, the rotatable handle includes additional moving parts that may be susceptible to breaking. Additionally, when the handle portion is rotated over of the top of the luggage case, it may interfere with a user attempting to gain access to the inside of the luggage case from the top.

[0008] What is needed in the art is a wheeled upright luggage case design with an extendable handle mechanism mounted adjacent to and preferably on one of the broad outside wall structures of the luggage case that maintains its balance when tipped and rolled in a direction substantially parallel to its wide dimension without the need to adjust the orientation of the handle.

SUMMARY OF THE INVENTION

[0009] The instant invention provides a wheeled upright luggage case with an extendable handle mechanism

mounted adjacent to a broad side wall structure of the luggage case with a wheel placement and configuration such that the luggage case maintains its balance when tipped and pulled in a direction substantially parallel to its wide dimension even if the center of gravity of the luggage case has shifted.

[0010] In one particular aspect of the invention, a wheeled luggage case includes a main body having a top surface, a bottom surface, a front wall, a rear wall, a first side wall, and a second side wall; an extendable handle mounted adjacent to the rear wall; a first wheel and a second wheel rotatably and operably connected with a rear edge; the rear edge defined by an intersection of the rear wall and the bottom surface; a first rearward side wheel and a first frontward side wheel rotatably and operably connected with a first side edge, the first side edge defined by an intersection of the first side wall and the bottom surface; and wherein a first distance from the first side edge to a first contact point of the first frontward side wheel is greater than a second distance from the first side edge to a second contact point of the first rearward side wheel.

[0011] In another scenario of the present invention, a luggage case includes a main body having a top surface, a bottom surface, a front wall, a rear wall, a first side wall, and a second side wall; an extendable handle mounted adjacent to the rear wall; wherein the first wall and the second wall separate the front wall from the rear wall. Further wherein a first width of the first wall and the second wall define a narrow dimension, and a second width of the front wall and the rear wall define a wide dimension. Also including a means for rolling the luggage case in a first direction substantially parallel to the narrow dimension; a means for rolling the luggage case in a second direction substantially parallel to the wide dimension; and a means for tilting the luggage case toward the rear wall when rolling in the second direction.

[0012] In a further representation of the instant invention, a wheeled luggage case includes a main body having a top surface, a bottom surface, a front wall, a rear wall, a first side wall, and a second side wall, wherein the front wall and the rear wall are wider than the first side wall and the second side wall; an extendable handle mounted adjacent to the rear wall; at least one rear wheel rotatably and operably connected with a rear edge, the rear edge defined by an intersection of the rear wall and the bottom surface; at least one side wheel rotatably and operably connected with a first side edge, the first side edge defined by an intersection of the first side wall and the bottom surface; and wherein the wheeled luggage case tilts toward the rear wall when supported by the at least one side wheel.

[0013] The features, utilities, and advantages of various embodiments of the invention will be apparent from the following more particular description of embodiments of the invention as illustrated in the accompanying drawings and defined in the appended claims.

BRIEF DESCRIPTION OF THE DRAWINGS

[0014] FIG. 1 is a front left-side perspective view of a luggage case.

[0015] FIG. 2 is a rear right-side perspective view of the luggage case in FIG. 1.

[0016] FIG. 3 is a view of the luggage case depicted in FIGS. 1 and 2 in an opened configuration depicting one embodiment of a main packing compartment of the luggage case.

[0017] FIG. 4 is a bottom plan view of the luggage case.

[0018] FIG. 5 is a rear right-bottom detailed perspective view of a wheel housing.

[0019] FIG. 6 is a front right-bottom detailed perspective view of a glide.

[0020] FIG. 7 is a fragmentary front view of the luggage case at rest on a surface.

[0021] FIG. 8 is a fragmentary right side view of the luggage case at rest on a surface.

[0022] FIG. 9 is a fragmentary right side view of the luggage case supported by rear wheels.

[0023] FIG. 10 is a fragmentary front view of the luggage case supported by side wheels.

[0024] FIG. 11 is a fragmentary rear view of the luggage case supported by side wheels.

[0025] FIG. 12 is a fragmentary front view of the luggage case supported by side wheels showing a first distance from a left edge to a first contact point.

[0026] FIG. 13 is a fragmentary rear view of the luggage case supported by side wheels showing a second distance from the left edge to a second contact point.

[0027] FIG. 14 is a fragmentary right side view of the luggage case supported by side wheels.

[0028] FIG. 15 is a side view of the luggage case supported by side wheels depicting a support triangle.

DETAILED DESCRIPTION OF THE INVENTION

[0029] FIG. 1 shows a front left-side perspective view of a luggage case 30 conforming to the present invention, and FIG. 2 shows a rear right-side perspective view of the luggage case shown in FIG. 1. The luggage case 30 includes a generally rectangular enclosure 32 defined by a front wall 34, a rear wall 36, a right wall 38, and a left wall 40, all extending vertically from a bottom surface 42 to a top surface 44. The front and rear walls are generally wider than the left and right walls. The width of the front and rear walls define a wide dimension, D_w , and the width of the right and left walls define a narrow dimension, D_n , of the luggage case.

[0030] The luggage case also includes an extendable handle mechanism 46 that is stored within and adjacent to the rear wall 36. The handle mechanism 46 comprises a handle 48 attached to extendable handle support posts 50. FIG. 1 shows the extendable handle mechanism 46 in a retracted position, while FIG. 2 shows the extendable handle mechanism 46 in an extended position. When a user desires to roll the luggage case 30, the user grasps the handle 48 and pulls the extendable handle mechanism 46 from its stored position to its extended position. The user then tips, pulls, and rolls the luggage case 30 in the direction desired. Use of the extendable handle mechanism 46 in conjunction with rolling the luggage case 30 is described below in more detail. Other

handles may be placed on the luggage case **30** as desired to allow the user to carry the luggage case in situations not suitable for rolling, such as storing the luggage in an overhead bin. For example, **FIGS. 1 and 2** show a first strap handle **52** on the top surface **44** of the luggage case **30**, and a second strap handle **54** on the right wall **38** of the luggage case **30**.

[0031] The luggage case **30** shown in **FIGS. 1 and 2**, including the handle, may be constructed in any known manner, and should not be construed to be limited to what is depicted. For example, in one embodiment, an outer jacket **56** of the luggage case is generally constructed of textile materials stitched together in various panels to form the overall luggage case **30**. The luggage case **30** may be divided into two halves **58** along its narrow dimension, D_N . Each half **58** of the luggage case **30** may also be hinged, such as with a self hinge, along a vertical joint by a textile strip forming a hinge **60**. **FIG. 1** shows the hinge **60** located on the left side **40** of the luggage case **30**, and the top surface **44**, right side **38**, and bottom surface **42** are selectively attached together by a continuous zipper track **62**. The luggage case **30** may also be supported on its inside with a pair of frames located parallel to one another. Each frame extends around the inside of the luggage case adjacent to the top surface **44**, right wall **38**, bottom surface **42**, and left wall **40**. The frames are substantially identical to the each other and may be constructed of extruded ABS plastic, having a generally honeycomb cross-sectional shape of known type. Therefore, the frames gives each half of the case a generally rigid construction.

[0032] The interior of the luggage case may also be configured in various ways, and should not be construed to be limited to what is depicted herein. For example, **FIG. 3** shows the luggage case **30** depicted in **FIGS. 1 and 2** in an opened configuration depicting one embodiment of a main packing compartment **64** of the luggage case **30**. A traveler may store the bulk of his or her belongings within each half **58** of the luggage case **30**. A mesh divider panel **66** with zippered access **68** closes each half **58** of the luggage case. The mesh divider **66** may be essentially non-structural and is provided to prevent the goods of the traveler from spilling out when the luggage case **30** is opened.

[0033] The luggage case **30** may also include pockets or pouches attached to the outside of the walls or top surface in various configurations. For example, the luggage case shown in **FIGS. 1 and 2** has a top zippered pocket **68** and a bottom zippered pocket **70** attached to the outside of the front wall **34** for containing additional goods of a traveler. The luggage case **30** depicted also has a zippered pouch **72** on the outside of the rear wall **36**. A user may choose to place items in pockets or pouches attached to the outside of the luggage to allow for easy access to them without the need to open the main packing compartment **64** for retrieval of these items.

[0034] **FIG. 4** shows a bottom view of the luggage case **30** depicted in **FIG. 1**. As shown in **FIG. 4**, the luggage case **30** has six wheels **74**. However, it should be understood that the luggage case may have more or less wheels **74** than what is depicted. Referring now to **FIGS. 1, 2, and 4**, a rear edge **76** is defined by the intersection of the rear wall **36** and the bottom surface **42**, and a front edge **78** is defined by the intersection of the front wall **34** and the bottom surface **44**.

A left edge **80** is defined by the intersection of the left wall **40** and the bottom surface **42**, and a right edge **82** is defined by the intersection of the right wall **38** and the bottom surface **42** of the luggage case **30**. Rear wheels **84**, a left rear wheel **86** and a right rear wheel **88**, are mounted along the rear edge **76** of the luggage case **30**. Side wheels **90**, a frontward left wheel **92** and a rearward left wheel **94**, are mounted on the left edge **80**. Side wheels **90**, a frontward right wheel **96** and a rearward right wheel **98**, are also mounted on the right edge **82**. Although the wheels **74** need not be located on the bottom edges of the luggage case **30**, locating the wheels on or near the bottom edges of the luggage case allows the luggage case to be tipped nearly 90° from its upright position without the bottom surface **42** coming into contact with the support surface or floor.

[0035] The wheels **74** may be attached to the luggage case in various ways. In one embodiment, the rear wheels **84** and the rearward side wheels (**94, 98**) are rotatably mounted to wheel housings **100** that are attached to the luggage case **30** as shown in **FIGS. 4, 5, and 6**. Referring now to **FIGS. 5 and 6**, the right wheel housing **100** has a rear portion **102**, a side portion **104**, and a bottom portion **106** which conform to the shape of the right rear corner of the luggage case **30**. As shown to **FIG. 5**, the right wheel housing **100** includes a cavity **108** in which an axle **110** of the right rear wheel **88** is mounted such that the axle **110** is substantially parallel to the rear edge **76** of the luggage case **30**. Mounting the right rear wheel **88** in the cavity **108** permits the wheel housing **100** to serve as a rub rail or skid when the luggage case is dragged over a curb or a stair tread of a stairway. The rear portion **102** of the wheel housing also protects the luggage case **30** from scrapes and tears. The rear wall **36** of the luggage case **30** may also be reinforced with protective material **112** to provide further protection, as shown in **FIGS. 2 and 5**. As shown in **FIGS. 5 and 6**, the right wheel housing **100** has a front wheel wall **114** (**FIG. 6**) and a rear wheel wall **116** extending from the side surface **104** of the wheel housing **100**. An axle **118** of the rearward right wheel **98** is mounted between the front **114** and rear **116** wheel walls such that the axle **118** is substantially perpendicular to the axle **110** of the right rear wheel **88**. The left rear wheel **86** and rearward left wheel **94** are similarly mounted to a left wheel housing **100** which is a mirror image of the right wheel housing **100**.

[0036] The wheel housings **100** may be constructed of any suitable materials, such as plastic or the like. In one embodiment, the wheel housings **100** are constructed of plastic using an injection molding process. In addition, the wheel housings may be attached to the exterior of the luggage case by any suitable means such as glue, rivets, stitching, or the like.

[0037] As shown in **FIGS. 4, 5, and 6**, the frontward right wheel **96** is rotatably mounted to a right glide **120**. The right glide **120** is attached to the bottom surface **42** and right wall **38** of the luggage case and generally conforms to the shape of the right edge **82** of the luggage case **30**. The right glide **120** has a bottom support **122**, and further includes a second front wheel wall **124** and a second rear wheel wall **126** extending in a direction away from the right edge **82** of the luggage case **30**. An axle **128** of the frontward right wheel **96** is mounted between the second front **124** and second rear **126** wheel walls of the right glide **120** such that the axle **128** is substantially parallel to the axle **118** of the rearward right

wheel 98. The frontward left wheel 92 is similarly mounted to a left glide 120 that is a mirror image of the right glide 120. The glides may be attached to the exterior of the luggage case by any suitable means such as glue, rivets, stitching, or the like. In addition, the glides may be constructed of any suitable materials, such as plastic or the like.

[0038] FIG. 7 shows a fragmentary front view of the luggage case 30, and FIG. 8 shows a fragmentary right-side view of the luggage case 30 when resting on a support surface 130. In the position depicted in FIGS. 7 and 8, the luggage case is supported by the rear wheels 84 and the bottom supports 122 of the glides 120. In an embodiment where a user may be expected to roll the luggage case primarily on the rear wheels 84, the side wheels 90 may have smaller diameters than the rear wheels 84. The smaller diameter of the side wheels also helps to place the side wheels 90 out of contact with the support surface 130 when the luggage case 30 is resting on the support surface, as shown in FIGS. 7 and 8. In order to move the luggage case by rolling it on the rear wheels 84, a user grasps the handle 48 and pulls the extendable handle mechanism 46 from its stored position to its extended position, as previously discussed and shown in FIG. 2. The user then tips the luggage case 30 rearwardly until the luggage case is supported on the support surface 130 solely by the rear wheels 84, as shown in FIG. 9. The user may then pull on the handle 48 to roll the luggage case 30 on the rear wheels 84 in a direction parallel to its narrow dimension, D_N . As shown in FIG. 9, the smaller diameters of the side wheels 90 help to place the side wheels out of contact with the support surface 130 when the luggage case 30 is being rolled on the rear wheels 84.

[0039] When a user desires to maneuver the luggage case 30 down an aisle or a passageway that may be too narrow to easily roll the luggage case in a direction parallel to its narrow dimension, D_N , the user may first grasp the handle 48 and pull the extendable handle mechanism 46 from its stored position to its extended position, as previously discussed and shown in FIG. 2. The user then tips the luggage case 30 sideways (i.e., toward a narrow side) until the luggage case is supported on the support surface 130 solely by the side wheels 90. FIG. 10 shows a fragmentary front view of the luggage case 90 supported on two side wheels 90, and FIG. 11 shows a rear view of the luggage supported on two sides wheels 90. The user may then pull on the handle 48 to roll the luggage case 30 on the side wheels 90 in a direction substantially parallel to its wide dimension, D_W .

[0040] A center of gravity, C_G , of the luggage case 30 typically tends to be located somewhere in a geometric center of the luggage case. In an embodiment where the luggage case is shaped like a rectangular enclosure, the center of gravity, C_G , should lie between the rear wheels 84 or the side wheels 90 whether the case is standing erect, being pulled while supported on its rear wheels 84, or being pulled while being supported on its side wheels 90. However, depending upon how the luggage case 30 is packed, the center of gravity, C_G , may shift toward the front wall 34 or rear wall 36 of the luggage case 30. For example, if a user fills pockets or pouches (68, 70) located on the front wall 34 of the luggage case 30 with extra goods, the center of gravity, C_G , may shift toward the front wall 34 of the luggage case 30. Shifting the center of gravity, C_G , too far toward the front wall 34 of the luggage case 30 may cause the luggage case tip over when at rest on the support surface

130. This problem may be overcome by placing glides 120 on the bottom surface 42 of the luggage case with bottom supports 122 extending down from the bottom surface 42 of the luggage case far enough such that the case tilts toward the back wall 36 when at rest on the support surfaces 130. Tilting the luggage case 30 toward the back wall 36 tends to move the center of gravity, C_G , away from the front wall 34 and helps to prevent to luggage case 30 from tipping over frontwards when a user, for instance, packs extra goods in front pockets (68, 70) attached to the front wall 34.

[0041] Packing the luggage case 30 in such a manner that the center of gravity, C_G , shifts toward the front wall 34 of the luggage case 30 may also present a problem with stability when the luggage case 30 is rolled in a direction parallel to its wide dimension, D_W (i.e., supported on side wheels). This is because when the user is rolling the luggage case 30 in a direction parallel to its wide dimension, D_W , the user's hand is not in a proper position on the handle 48 to effectively counteract, support or resist tipping of the luggage case toward the front wall 34. This is because the handle extends from the rear wall of the luggage case, and the user's leverage, and thus control, of a frontward tipping luggage case is reduced. This problem is overcome by designing the luggage case 30 in such a way that it tilts toward the back wall 36 when rolled in a direction parallel to its wide dimension, D_W (i.e., supported on side wheels). However, should the luggage case 30 be packed in such a way that the center of gravity, C_G , shifts toward the rear wall 36 of the luggage case, the user's hand 48 placed on the handle 48 is in a proper position to resist tipping toward the rear wall when rolling the luggage case in a direction parallel to its wide dimension, D_W . This is because the handle extends from the rear wall and thus provides good leverage and support to resist rearward tipping luggage.

[0042] The geometry and arrangement of the side wheels 90 relative to the bottom 42 and sides (38, 40) of the luggage case 30 is helpful in order to prevent the luggage case from tipping toward the front wall 34 when rolling in a direction parallel to its wide dimension, D_W (i.e., supported on side wheels). FIG. 12 shows a front fragmentary view of the luggage case 30, and FIG. 13 shows a rear fragmentary view of the luggage case 30 while supported on the right side wheels 90. As shown in FIG. 12, a first point of contact 132 is defined where the frontward right wheel 96 contacts the support surface 130. A portion of the front wall 34 of the luggage case 30 is cut out of the drawing in order to show the right edge 82 of the luggage case 30 located directly above the first point of contact 132. The distance between the right edge 82 and the first point of contact 132 is defined by a dimension, D_F . As shown in FIG. 13, a second point of contact 134 is defined where the rearward right wheel contacts the support surface. A portion of the right wheel housing 100 and rear wall 36 of the luggage case 30 is cut out of the drawing in order to show the right edge 82 of the luggage case located directly above the second point of contact 134. The distance between the right edge 82 and the second point of contact 134 is defined by a dimension, D_R .

[0043] When dimension D_F is greater than dimension D_R , the luggage case 30 tilts toward the rear wall 36 to define a tilt angle, A_T , from vertical when it is being rolled in the direction parallel to its wide dimension, D_W (i.e., supported by side wheels), as shown in FIG. 14. FIG. 15 shows a right side view of the luggage case 30 supported by two side

wheels **90** conforming to the present invention. A support triangle **136** is defined by the first **132** and second **134** contact points and the handle **48** supported by the user. The luggage case **30** is more stable when the center of gravity, C_G , is located inside the support triangle **136**. Tilting the luggage case **30** toward the rear wall **36** tends to more dependably place the center of gravity, C_G , between the contact points (**132**, **134**) and more importantly, within the support triangle **136**. This is true even though a substantial portion of the luggage case, in particular, virtually the entire front wall **34** with its front pockets (**68**, **70**), and much of the volume of the main packing compartment **64** toward the upper surface of the luggage case falls outside of the support triangle **136**. When the luggage case **30** tilts toward the rear wall **36**, the luggage case becomes more stable and resistive to tipping as the luggage case is rolled in a direction parallel to its wide dimension, D_W (i.e., supported on side wheels) and when it has been packed such that the center of gravity, C_G , shifts toward the front wall **34**.

[0044] The wheels **74** and associated geometry may be configured in various ways to achieve the benefits of the present invention. In one embodiment, all of the side wheels **90** have the same diameter. Thus, the respective mount for the side wheels **90** mounted on the glides **120** is spaced farther from the side edges (**80**, **82**) of the luggage case **30** than the side wheels **90** mounted on the wheel housings **100**. In different embodiments, dimensions D_F and D_R may have varying combinations of distances. For example, in one embodiment, D_F is $1\frac{1}{16}$ inches and D_R is $1\frac{3}{8}$ inches. This geometry results in the luggage case **30** tilting toward the rear wall **36** at about 7° from vertical.

[0045] It has been found that different combinations of D_F and D_R may also achieve better results depending upon the type of luggage case used. For example, in a split-case configuration, there is substantial flex or movement between the two framed portions **58** of the case **30**. This flex or movement occurs mostly in the zipper tape **62** holding together the two separately framed portions **58** together during wheeling. Therefore, some of the potential compensation tipping toward the rear wall **36** provided by the frontward side wheel is absorbed by the flexing between the frames. However, a luggage case having a truly rigid, one-piece bottom surface, which is more typical for upright luggage cases, may not require arranging the side wheels as severely, because there is little or no flexing.

[0046] It should be understood that the present invention can be applied to luggage having various geometric shapes and internal or external features, and is not limited to the luggage case disclosed herein. Other embodiments of the present invention may utilize various configurations and combinations of wheel sizes, spacing and/or glide support spacing to achieve the desired orientation of the luggage case when at rest on a support surface to prevent tipping. For example, when the luggage case is designed or packed in such a manner that the center of gravity is positioned in a location where the luggage case tends to tip in one direction, the tendency to tip can be overcome by configuring the wheel spacing, sizes, and/or glide supports such that the luggage case leans in a direction opposite of the tipping direction.

[0047] Similarly, other embodiments of the present invention may utilize various configurations and combinations of

wheel sizes and/or spacing to achieve the desired orientation of the luggage case when rolling to prevent tipping. For example, wheel sizing and/or spacing in various configurations or combinations may be used to overcome a luggage case's tendency to tip in one direction by causing the luggage to lean in a direction opposite of the tipping direction when the luggage is rolling. More particularly, wheel spacing and/or sizes can be configured so that a first bottom edge of the luggage case is elevated higher from the support surface than a second bottom edge opposite the first bottom edge when the luggage case is being wheeled. This configuration causes the luggage case to lean in a direction away from the first bottom edge. Therefore, the design resulting in a tilt of the luggage case resists tipping when being wheeled where the center of gravity of the luggage case is located in a direction closer to a side adjacent the first bottom edge.

[0048] Although various embodiments of this invention have been described above with a certain degree of particularity or with reference to one or more individual embodiments, those skilled in the art could make numerous alterations to those disclosed embodiments without departing from the spirit or scope of this invention. It is intended that all matter contained in the above description and shown in the accompanying drawings shall be interpreted as illustrative only of particular embodiments, and not limiting. Changes in detail or structure may be made without departing from the basic elements of the invention as defined in the following claims. For example, the preferred embodiment is a so-called split case. Other case configurations, such as a lid-opening case, could also benefit from this invention.

What is claimed is:

1. A wheeled luggage case comprising:

a main body having a top surface, a bottom surface, a front wall, a rear wall, a first side wall, and a second side wall;

an extendable handle mounted adjacent to said rear wall;

a first wheel and a second wheel rotatably operably connected with a rear edge, said rear edge defined by an intersection of said rear wall and said bottom surface;

a first rearward side wheel and a first frontward side wheel rotatably operably connected with a first side edge, said first side edge defined by an intersection of said first side wall and said bottom surface; and

wherein a first distance from said first side edge to a first contact point of said first frontward side wheel is greater than a second distance from said first side edge to a second contact point of said first rearward side wheel.

2. The wheeled luggage case of claim 1 further comprising a first wheel housing, wherein said first wheel is mounted on an a first axle, and said first axle is mounted on said first wheel housing, and said first rearward side wheel is mounted on a first side axle, and said first side axle is mounted on said first wheel housing.

3. The wheeled luggage case of claim 2 wherein said first wheel housing defines a cavity in which said first axle is mounted.

4. The wheeled luggage case of claim 2 wherein said first axle is substantially perpendicular to said first side axle.

5. The wheeled luggage case of claim 2 wherein said first wheel housing is constructed of molded plastic.

6. The wheeled luggage case of claim 1 further comprising a first glide, wherein said first frontward side wheel is mounted on a second side axle, and said second side axle is mounted on said first glide.

7. The wheeled luggage case of claim 6 wherein said first glide is constructed of molded plastic.

8. The wheeled luggage case of claim 1 wherein said main body tilts toward said rear wall when resting on a support surface.

9. The wheeled luggage case of claim 1 wherein said first distance is 1¹/₁₆ inches, and said second distance is 1³/₈ inches.

10. The wheeled luggage case of claim 1 wherein said main body tilts toward said rear wall at a tilt angle measured from vertical when said wheeled luggage case is supported on said first rearward side wheel and said first frontward side wheel.

11. The wheeled luggage case of claim 10 wherein said tilt angle is at least approximately 7°.

12. The wheeled luggage case of claim 1 wherein said bottom surface is rigid.

13. The wheeled luggage case of claim 1 wherein said bottom surface is made of an integral piece.

14. The wheeled luggage case of claim 1 further comprising:

a second rearward side wheel and a second frontward side wheel rotatably connected with a second side edge, said second side edge defined by an intersection of said second side wall and said bottom surface; and

wherein a third distance from said second side edge to a third contact point of said second frontward side wheel is greater than a fourth distance from said second side edge to a fourth contact point of said second rearward side wheel.

15. The wheeled luggage case of claim 14 further comprising a first wheel housing and a second wheel housing;

wherein said first wheel is mounted on a first axle, and said first axle is mounted on said first wheel housing, and said first rearward side wheel is mounted on a first side axle, and said first side axle is mounted on said first wheel housing; and

wherein said second wheel is mounted on a second axle, and said second axle is mounted on said second wheel housing, and said second rearward side wheel is mounted on a second side axle, and said second side axle is mounted on said second wheel housing.

16. The wheeled luggage case of claim 15 wherein said first wheel housing defines a first cavity in which said first axle is mounted, and said second wheel housing defines a second cavity in which said second axle is mounted.

17. The wheeled luggage case of claim 15 wherein said first axle is substantially perpendicular to said first side axle, and said second axle is substantially perpendicular to said second side axle.

18. The wheeled luggage case of claim 15 wherein said first wheel housing and said second wheel housing are constructed of molded plastic.

19. The wheeled luggage case of claim 14 further comprising a first glide and a second glide;

wherein said first frontward side wheel is mounted on a third side axle, and said third side axle is mounted on said first glide; and

wherein said second frontward side wheel is mounted on a fourth side axle, and said fourth side axle is mounted on said second glide.

20. The wheeled luggage case of claim 19 wherein said first glide and said second glide are constructed of molded plastic.

21. The wheeled luggage case of claim 14 wherein said third distance is 1¹/₁₆ inches, and said fourth distance is 1³/₈ inches.

22. The wheeled luggage case of claim 14 wherein said wheeled luggage case tilts toward said rear wall at a tilt angle measured from vertical when said wheeled luggage case is supported on said second rearward side wheel and said second frontward side wheel.

23. The wheeled luggage case of claim 22 wherein said tilt angle is at least approximately 7°.

24. A luggage case comprising:

a main body having a top surface, a bottom surface, a front wall, a rear wall, a first side wall, and a second side wall;

an extendable handle mounted adjacent to said rear wall; wherein said first wall and said second wall separate said front wall from said rear wall;

wherein a first width of said first wall and said second wall define a narrow dimension, and a second width of said front wall and said rear wall define a wide dimension;

a means for rolling said luggage case in a first direction substantially parallel to said narrow dimension;

a means for rolling said luggage case in a second direction substantially parallel to said wide dimension; and

a means for tilting said luggage case toward said rear wall when rolling in said second direction.

25. A wheeled luggage case comprising:

a main body having a top surface, a bottom surface, a front wall, a rear wall, a first side wall, and a second side wall, wherein said front wall and said rear wall are wider than said first side wall and said second side wall;

an extendable handle mounted adjacent to said rear wall;

at least one rear wheel rotatably operably connected with a rear edge, said rear edge defined by an intersection of said rear wall and said bottom surface;

at least one side wheel rotatably operably connected with a first side edge, said first side edge defined by an intersection of said first side wall and said bottom surface; and

wherein said wheeled luggage case tilts toward the rear wall when supported by said at least one side wheel.

* * * * *