



US 20040026558A1

(19) **United States**

(12) **Patent Application Publication**  
**Murphy**

(10) **Pub. No.: US 2004/0026558 A1**

(43) **Pub. Date: Feb. 12, 2004**

(54) **CABLE MANAGEMENT SYSTEM**

(52) **U.S. Cl. .... 242/404.3; 242/400.1; 242/594.5**

(76) **Inventor: Steven Charles Murphy, Elko, NV (US)**

(57) **ABSTRACT**

Correspondence Address:  
**STEVEN CHARLES MURPHY**  
**345 ASH STREET**  
**ELKO, NV 89801 (US)**

A cable management system includes a horizontal support assembly (1) and a cable holder assembly (5). The cable holder assembly (5) consists of a cable holder (3) with hooks (8) and a cable holder cover (4). Excess cable, wire, line or cord is wrapped around the cable holder (3) and the cable holder cover (4) is installed. The cable holder assembly (5) is then hooked onto the horizontal support assembly (1). The cable management system manages, organizes, stores, protects and support the cables along a horizontal plane. Any cable holder assembly can be removed without disturbing the other cables. The system includes end pads (25), suction cups (26), top brackets (33), side brackets (38) and hanger brackets (41). Combined with the adjustable-length horizontal support assembly (1), these connectors allow the system to be installed on a wide variety of vertical (44) and horizontal (45) surfaces.

(21) **Appl. No.: 10/435,170**

(22) **Filed: May 10, 2003**

**Related U.S. Application Data**

(60) **Provisional application No. 60/379,953, filed on May 10, 2002.**

**Publication Classification**

(51) **Int. Cl.<sup>7</sup> ..... B65H 75/44**

**Front prospective view of a cable management system**

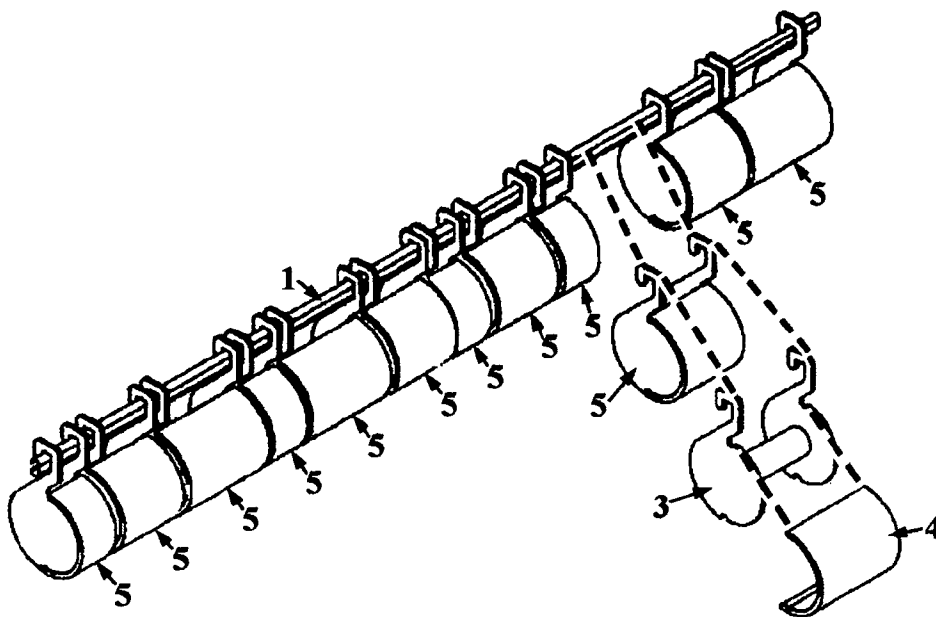

Front prospective view of a cable management system

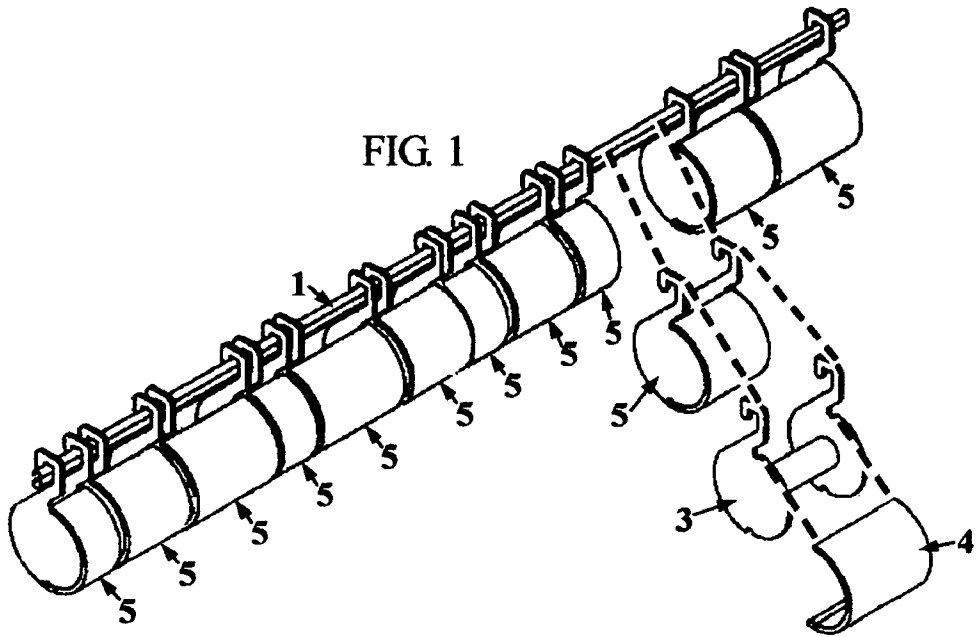

Front prospective view showing a horizontal support assembly

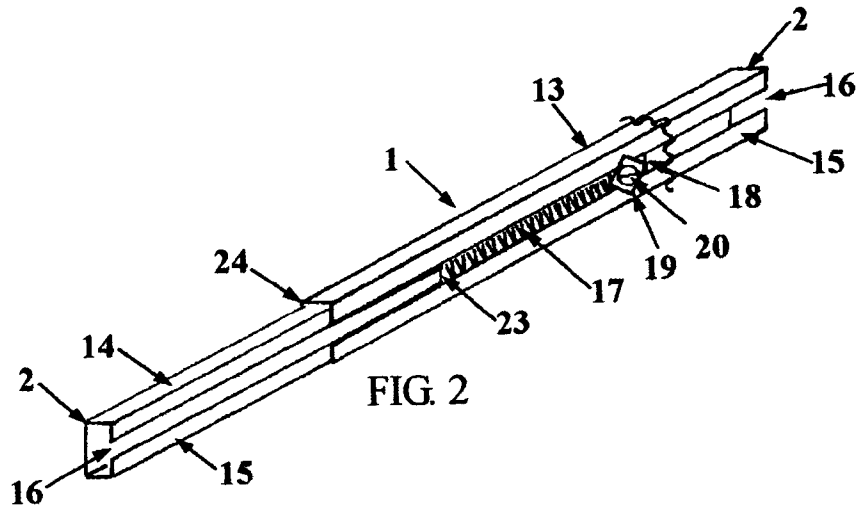

# Front prospective view showing a cable holder

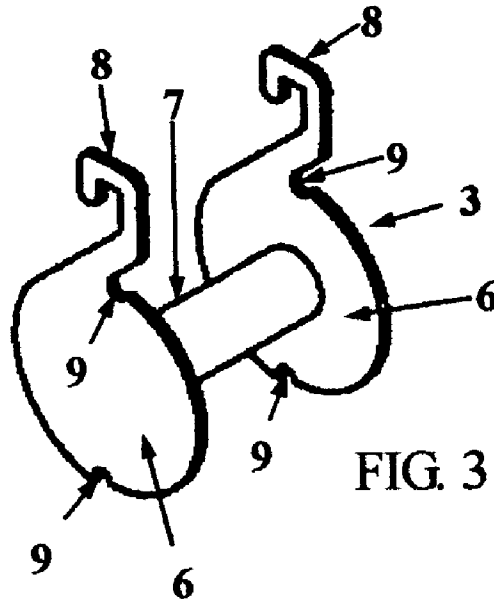

Front prospective view showing a cable holder cover

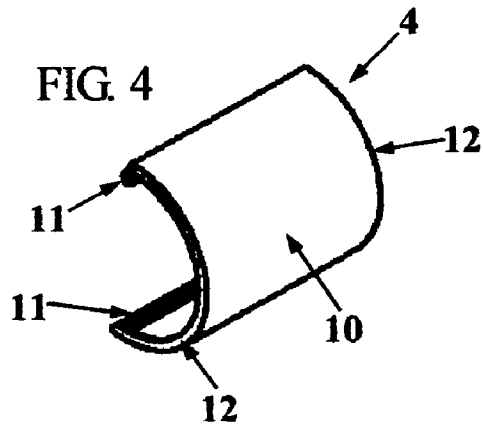

Front prospective view showing a cable holder assembly

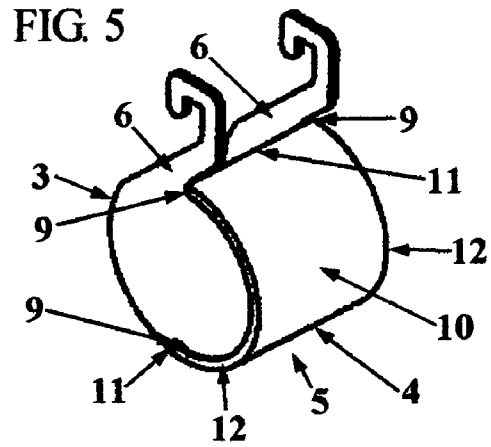

### Back prospective view of a horizontal support assembly and end pad

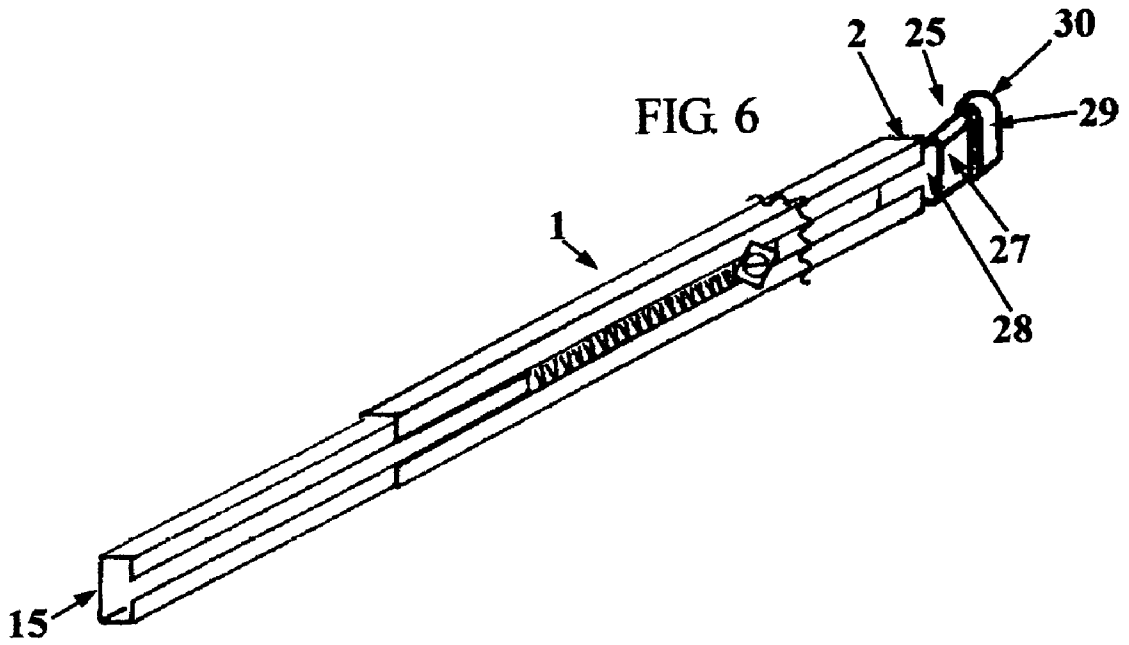

Front prospective partial view showing an end pad installation

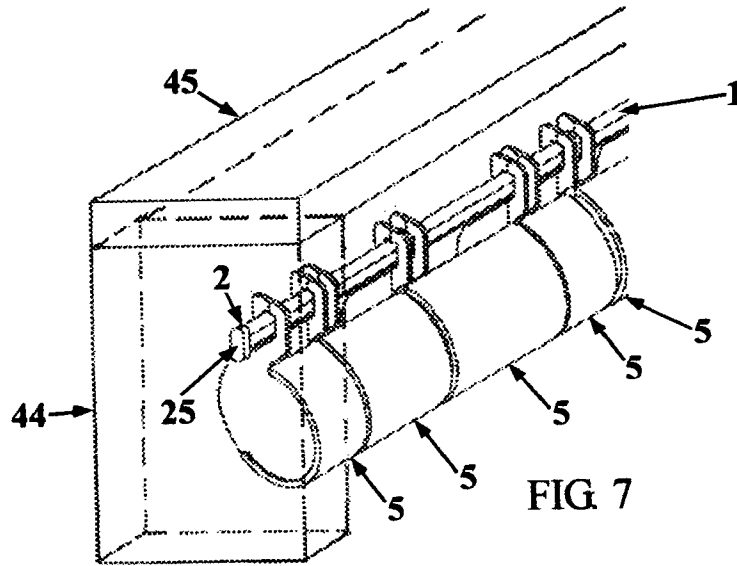



Back prospective view showing  
a horizontal support assembly and suction cup

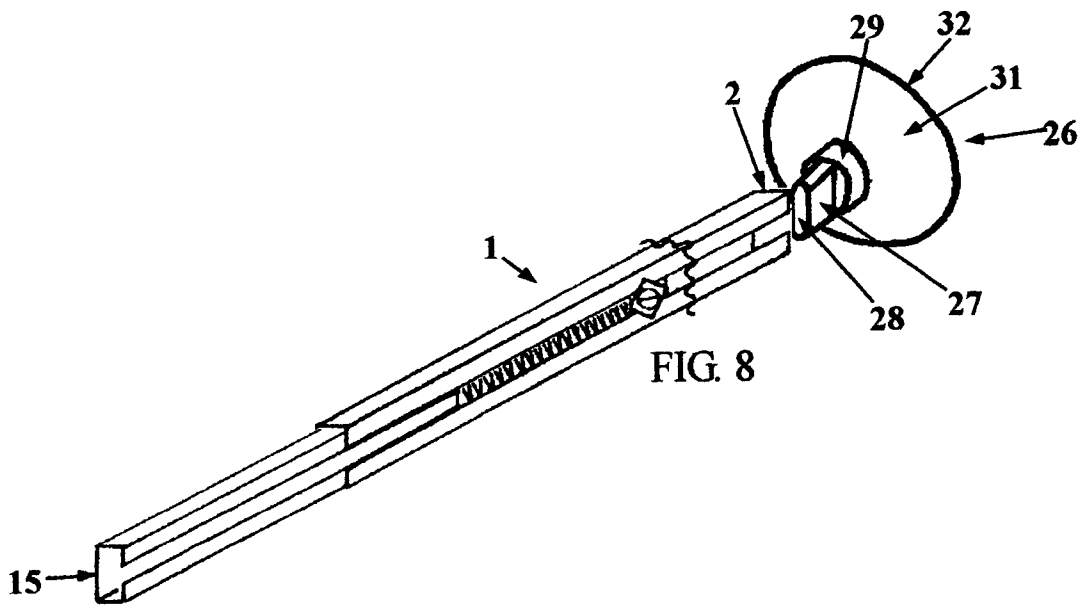

### Front prospective partial view of a suction cup installation

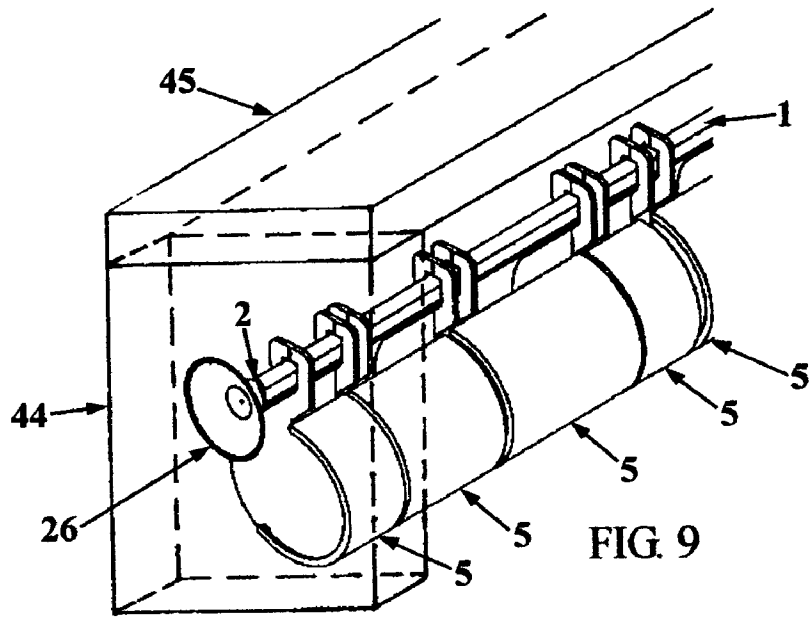

Back prospective view showing  
a horizontal support assembly and top bracket

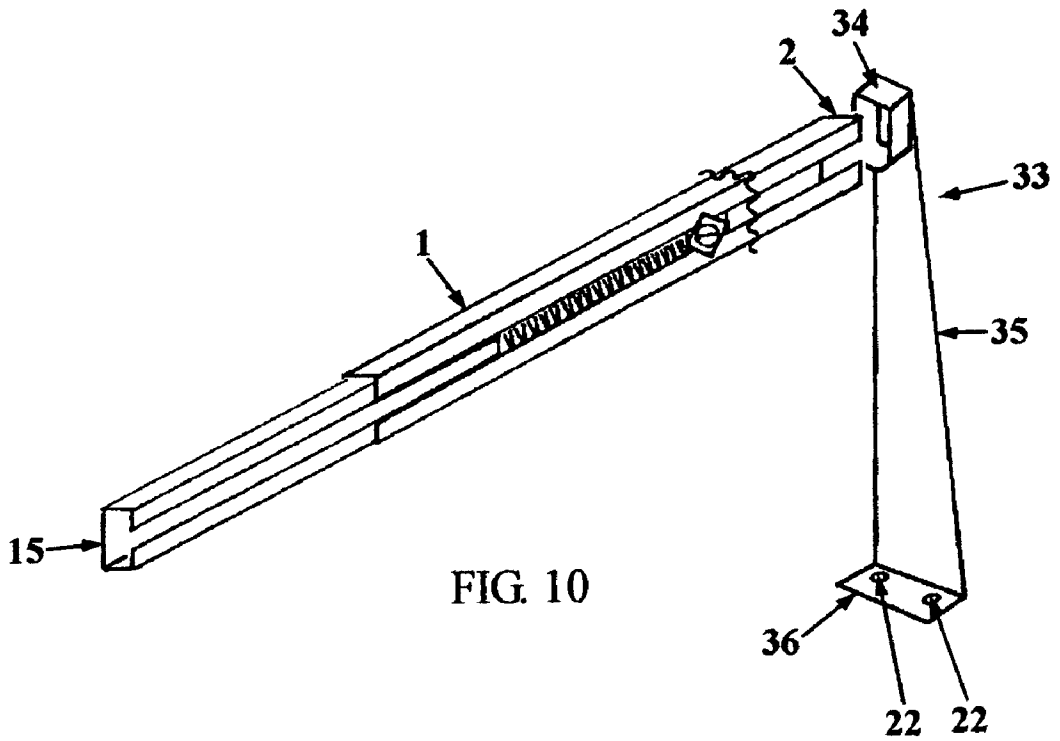
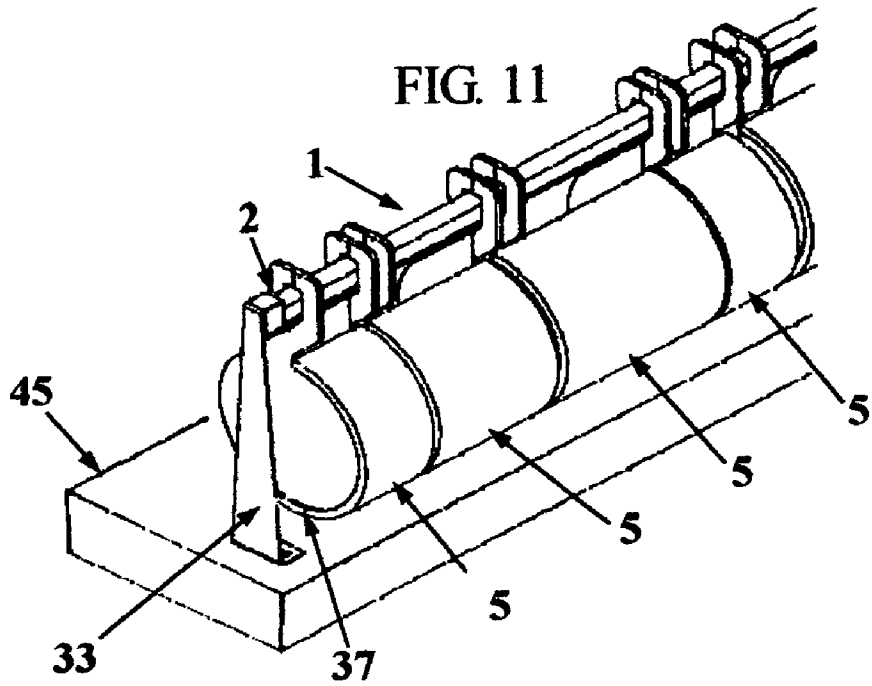
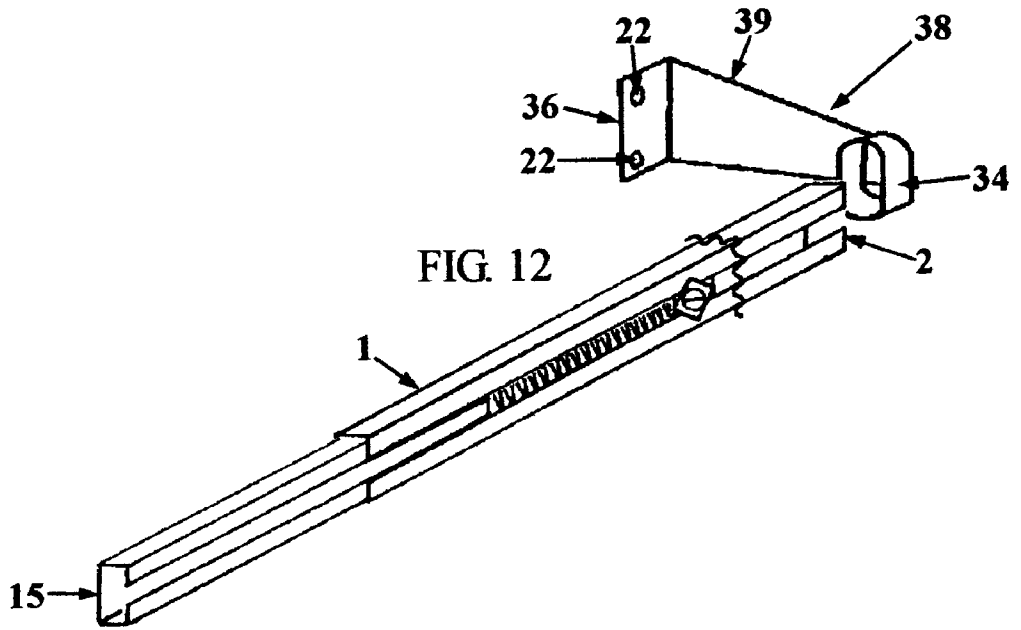

FIG. 10

# Front prospective partial view showing a top bracket installation



Back prospective view showing  
a horizontal support assembly and side bracket



Front prospective view showing a side bracket installation

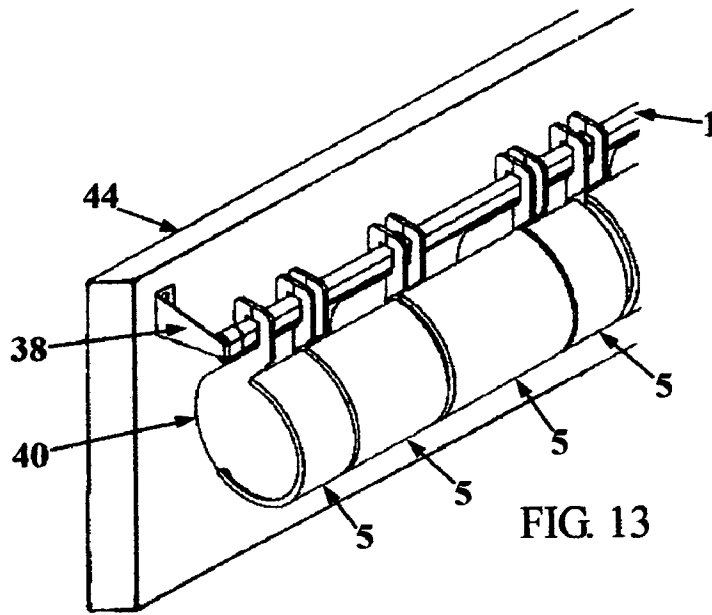

**Back prospective view showing a  
support assembly and hanger bracket**

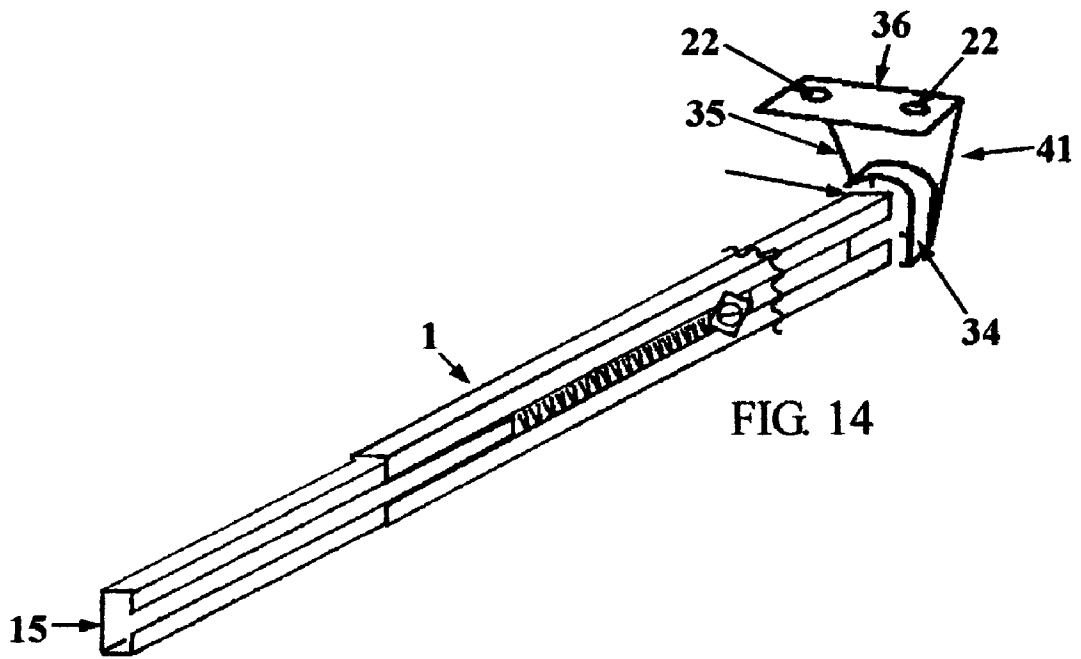

Front prospective parial view of a hanger bracket installation

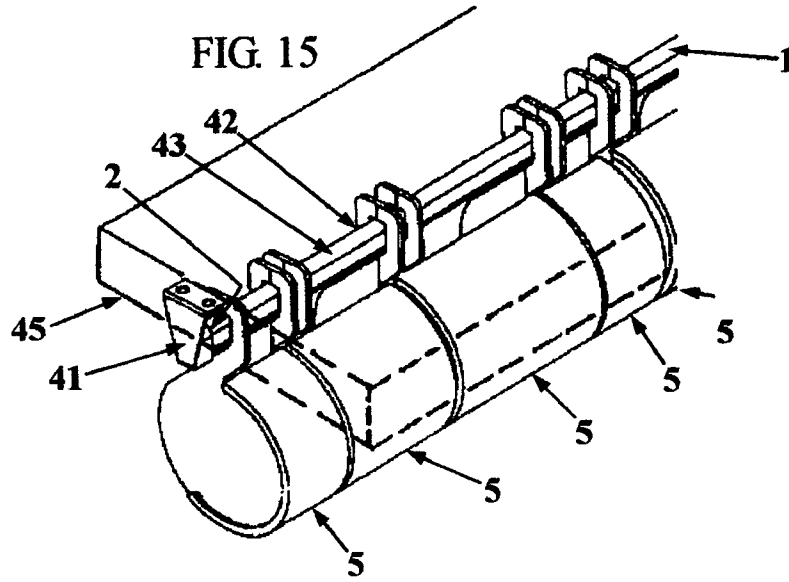



## CABLE MANAGEMENT SYSTEM

[0001] Authority is claimed of Provisional Patent Application No. 60/379,953 Filed on May 10, 2002

### BACKGROUND OF THE INVENTION

#### [0002] 1. Field of the Invention

[0003] This invention relates generally to wires, cables, lines and cords, particularly to a novel system of managing, organizing, storing, protecting and supporting a plurality of wires, cables, lines, cords and the like that connect equipment together. More particularly, the present invention includes a plurality of covered cable holders with hooks that are adjustable and detachable from a horizontal support assembly.

#### [0004] 2. Brief Description of the Related Art

[0005] In the fields of electronics, communications, and data transmission, equipment of many types are grouped together and connected by many cables, wires, lines, cords and the like (hereafter referred to as "cables"). These cables are made in many types, gauges and lengths. The equipment is usually connected together at the back by cables with plugs or by wire ends connected to terminal blocks on the equipment.

[0006] When equipment is connected together, a maze of loose, tangled and crossed cables is created. The cables become unmanageable due to disorganization, lack of protection and support.

[0007] Unmanageable cables make the task of disconnecting and reconnecting equipment laborious. Single pieces of equipment must be accessible for removal, replacement and service. With the tangled mess of cables, it is difficult to trace and disconnect single equipment cables without disconnecting other equipment. In order to untangle the cables from one piece of equipment, it is necessary to disconnect other equipment cables. In some cases, the entire system must be disconnected in order to access one piece of equipment. This is not only time-consuming, it results in sometimes disconnecting an entire system in order to access one piece of equipment.

[0008] Sagging cables can become damaged in a number of ways. Cables, plugs and terminal connections are stressed and damaged by their unsupported weight. Cable damage also occurs when loose cables become entangled with mobile service equipment, such as carts and cleaning equipment, and with people and animals. Cables, plugs and terminal connections can not only be damaged by stress caused by pulling, the equipment itself can be pulled from its' shelf and damaged or destroyed when it falls to the floor.

[0009] Exposed cables become a safety hazard to adults, children, and pets when entanglement occurs with contact. Such entanglement can occur behind the equipment, or when seated in front of the equipment. Such entanglement can result in possible injury by falling, slipping from a chair and the like.

[0010] Loose cables sagging on the floor trap dirt. It is difficult to clean around and under the cables without the cleaning equipment becoming entangled in the loose cables. Sagging cables also take up unnecessary space and curtail the efficient use of space.

[0011] Finally, loose cables are unsightly and inherently disorganized.

#### [0012] 3. Background of the Prior Art

[0013] The use of spools and reels as storage devices for cable is known in the prior art. More specifically, such devices include cable management systems such as cable spool systems, compartmentalized hanging bags and racks.

[0014] U.S. Pat. No. 4,721,268 to Lerner (1988) shows a system in which excess cable is stored in modular housings which nest together and are stacked together vertically. If one module is removed from the stack, the remaining upper modules will hang unsupported and will not nest with the lower portion of the stack.

[0015] In U.S. Pat. No. 4,744,471 to Leister (1988), a telescoping rod with locking device is shown.

[0016] In U.S. Pat. No. 5,600,098 to Kazaks (1997), loose cables are placed in a flexible fabric tube, which is then closed up by means of a zipper. The tube provides no means for separating the individual cables, thus making it difficult to remove any on cable from the tube. Also, no feature is included that supports the tube or allows the tube to be mounted.

[0017] In U.S. Pat. No. 5,613,648 to Paavila (1997), excess cable is stored by winding the cable onto a spool, which has a cover that holds the wound cable in place. However, no features are included that support the spool assembly or allow the spool assembly to be mounted.

[0018] In U.S. Pat. No. 5,779,366 to McKenzie, III et al (1998), excess cables are stored in divided pouches inside a bag hanging from the back of a desk. As the cables are stored in the bag from front to back, the protruding cable ends in the forward divider pouches are in the way when cables are removed from the back divider pouches. Thus, cables are difficult to remove unless all the forward cables are also removed, or the entire bag assembly is detached.

[0019] In U.S. Pat. No. 5,967,451 to Radaios (1999), cable is stored and dispensed from spools mounted inside a rack. The spools are held in place by a center shaft which is inserted through the center hole of the spools. Removal of the spools is not possible without removing the center shaft, thus individual spools cannot be easily removed, replaced or moved.

[0020] In U.S. Pat. No. 6,186,450 to Maillaro (2001), a single computer "mouse" cable is elevated and supported by a base with an upright swivel support rod. No consideration is given to storage of excess cable or to cable protection. No system is proposed that allows for removable and replacement of multiple cables.

[0021] In U.S. Pat. No. 6,398,149 to Hines et al (2002), excess cable is stored on spools that lock into position in a slot on a cable support channel. The system depends on the existence of support frames that the support channel is attached to with brackets and fasteners. Therefore, the location of the channel and spools depends on the location of the frames. In order to move the channel in any other location, the brackets and fasteners must be removed and reinstalled. Lateral support wires are used to trap the excess cable on the spool, but no cover is provided to protect the cable from the environment. The lateral support wires are

fixed on the spools and after the spools are installed, the lateral support wires are perpendicular to the support channel. Cable ends are fed through the middle of the lateral support wires in order to hold the cable and keep it from unrolling. Thus the cable ends can only exit the spools at 90 degrees from the support channel. This limits the exit angle of the cable ends.

#### OBJECTIVES AND ADVANTAGES

[0022] Accordingly, several objectives of the invention are to provide a complete cable management system which is easy and economical to manufacture, which allows the user to manage, organize, store, protect and support a wide variety of cables, wires and cords that connect equipment together, and to provide a quick and easy way to remove any one connection without disturbing the remaining connections.

[0023] Other objectives and advantages of the invention are to provide a cable management system which can be easily, quickly and securely be installed on a multitude of office fixture surfaces, including universal width adjustability and universal mountability between two opposed surfaces and to top, side, and underside surfaces.

[0024] Further objectives and advantages will become apparent from a study of the following description and the accompanying drawings.

#### DRAWING FIGURES

[0025] FIG. 1 is a front prospective view of a cable management system in accordance with the preferred embodiment of the invention.

[0026] FIG. 2 is a back prospective view showing a horizontal support assembly.

[0027] FIG. 3 is a front prospective view showing a cable holder.

[0028] FIG. 4 is a front prospective view showing a cable holder cover.

[0029] FIG. 5 is a front prospective view showing a cable holder assembly.

[0030] FIG. 6 is a back prospective view showing a horizontal support assembly and end pad.

[0031] FIG. 7 is a front prospective partial view showing an end pad installation.

[0032] FIG. 8 is a back prospective view showing a horizontal support assembly and suction cup.

[0033] FIG. 9 is a front prospective partial view showing a suction cup installation.

[0034] FIG. 10 is a back prospective view showing a horizontal support assembly and top bracket.

[0035] FIG. 11 is a front prospective partial view showing a top bracket installation.

[0036] FIG. 12 is a back prospective view showing a horizontal support assembly and side bracket.

[0037] FIG. 13 is a front prospective partial view showing a side bracket installation.

[0038] FIG. 14 is a back prospective view showing a horizontal support assembly and hanger brackets.

[0039] FIG. 15 is a front prospective partial view showing a hanger bracket installation.

#### REFERENCE NUMERAL LEGEND

##### [0040]

1. Horizontal Support Assembly	2. Support Assembly End	3. Cable Holder
4. Cable Holder Cover	5. Cable Holder Assembly	6. Side
7. Center	8. Hook	9. Notch
10. Cover Surface	11. Rib	12. Flange
13. Outer Channel	14. Inner Channel	15. Wide Side
16. Slot	17. Tension Spring	18. Inner Bracket
19. Outer Bracket	20. Screw	21. Threaded Hole
22. Pilot Hole	23. Stop End	24. Slider End
25. End Pads	26. Suction Cup	27. Tab
28. Tab Surface	29. Pad	30. Pad Surface
31. Suction Cup Surface	32. Suction Cup Edge	33. Top Bracket
34. Receptacle	35. Vertical Column	36. Base
37. Bottom Edge	38. Side Bracket	39. Horizontal Column
40. Back Edge	41. Hanger Bracket	42. Hook End Bottom
43. Top Edge	44. Vertical Surface	45. Horizontal Surface

#### SUMMARY OF INVENTION

[0041] Cable holder with detachable cable holder cover that attaches to a horizontal support assembly. Cables and the like are wrapped on the cable holder and held in place by the cable holder cover. The cable holder and cable holder cover form a cable holder assembly. The cable holder assembly is then attached to a horizontal support assembly. The support assembly is installed on the top, side or bottom of vertical and horizontal surfaces, and on opposing vertical surfaces, using various style brackets, pads, suction cups and the like. One or more cable holder assemblies are installed on the support assembly to create a cable management system.

#### DESCRIPTION OF INVENTION

[0042] Description—FIG. 1—Front Prospective View of a Cable Management System.

[0043] In accordance of a preferred embodiment of my cable management system as show in FIG. 1, a cable management system includes a cable holder 3, a cable holder cover 4 and a horizontal support assembly 1. When the cover 4 is installed on the holder 3, a cable holder assembly 5 is formed. One or more cable holder assemblies 5 are installed on the horizontal support assembly 1.

[0044] Description—FIG. 2—Back Prospective View Showing a Horizontal Support Assembly.

[0045] As shown in FIG. 2, the support assembly parts include an inner channel 14, an outer channel 13, a tension spring 17, an inner bracket 18, an outer bracket 19, and a screw 20.

[0046] Both the inner channel 14 and the outer channel 13 are rectangular in shape, with the wide side 15 having a vertical orientation. The ends 2 of the inner channel 14 are

identical in form. The ends 2 of the outer channel 13 are identical in form. The dimensions of the inner channel 14 are less than the dimensions of the outer channel 13 so that the inner channel 14 slides inside the outer channel 13. The difference between the dimensions of the inner channel 14 and the outer channel 13 is such that the fit between the two channels is tight but the parts are still capable of being slid back and forth by hand. Both the inner channel 14 and the outer channel 13 have a slot 16 centered horizontally on the wide side 15. The width of the slot 16 is such that that allows the screw 20 to pass unobstructed through the slots 16. The outer channel 13 has the support assembly end 2 and a slider end 24. The inner channel 14 has the support assembly end 2 and a stop end 23.

[0047] The tension spring 17 is formed by coiling a straight wire around a round shape. The gauge of the wire used is such that the compressed tension spring 17 produces tension adequate to achieve a holding force. The length of the tension spring 17 is such that a linear range of compression is achieved. The diameter of the tension spring 17 is such that the tension spring 17 slides inside the outer channel 13 and contacts the stop end 22 of the inner channel 14.

[0048] Both the inner bracket 18 and the outer bracket 19 are square, with the dimension of the square less than the inside dimension of the wide side 15 of the outer channel 13 and greater than the width of the slot 16. The inner bracket 18 has a threaded hole 21 which is centered on the inner bracket 18. The threads in hole 21 match the thread of the screw 20. The outer bracket 19 has a pilot hole 22, which is centered on the outer bracket 19. The pilot hold 22 has a dimension that allows the thread of the screw 20 to pass unobstructed through the outer bracket 19.

[0049] The stop end 23 of the inner channel 14 is located inside the outer channel 13. The tension spring 17 is located inside the outer channel 13, contacting the stop end 23 of the inner channel 14. The inner bracket 18 is located inside the outer channel 13 and contacts the spring 17. The outer bracket 19 is located on the outside of the outer channel 13 adjacent to the inner bracket 18. The screw 20 connects through the pilot hole 22 (not shown) of the outer bracket 19 to the threaded hole 21 (not shown) of the inner bracket 19. The support assembly 1 has two ends 2.

[0050] Description—FIG. 3—Front Prospective View Showing a Cable Holder.

[0051] Now looking at FIG. 3, in accordance of a preferred embodiment of my cable management system, the cable holder 3 consists of center 7 with two sides 6 attached to each end of the center 7. Each side 6 include a hook 8 and two notches 9.

[0052] The width of the center 7 and the dimensions and shape of the sides 6 varies according to the size and length of the cable to be stored. Thus a multitude of sizes of cable holders 3 are envisioned.

[0053] The inner rectangular dimension of the hook 8 is slightly larger than the rectangular shape of the support assembly 1 (not shown). The location of the hook 8 on the holder 3 is such that center of gravity of the holder 3 is vertically-centered.

[0054] Notches 9 are located on the top of each side 6 in front of the hook 8, where the hook 8 forms the back of the

notch 9. Notches 9 are located on the bottom of each side 6 in a location opposed to the notches 9 located on the top of each side 6. The shape of the notches 9 is a recession in the sides 6.

[0055] Description—FIG. 4—Front Prospective View Showing a Cable Holder Cover.

[0056] In FIG. 4, a cover 4 includes a cover surface 10, two ribs 11 and two flanges 12. The ribs 11 are elongated raises located on the upper and lower horizontal edges of the cover 4 and between the flanges 12. The flanges 12 are raised shapes along both curved vertical edges of the cover 4.

[0057] Description—FIG. 5—Front Prospective View Showing a Cable Holder Assembly.

[0058] Now looking at FIG. 5, in accordance of a preferred embodiment of my cable management system, a cable holder assembly includes the cable holder 3 and a cable holder cover 4. When the cover 4 is installed on the holder 3, the cable holder assembly 5 is created.

[0059] The cover surface 10 extends vertically from the notches 9 in the top of the sides 6 to the notches 9 in the bottom of the sides 6. The cover surface 10 extends horizontally from one side 6 to the other side 6. The thickness of the cover 4 is such that when the cover 4 is installed on holder 3, the cover 4 flexes before engaging the notches 9.

[0060] The depth and width of the notches 9 are such that when the ribs 11 of cover 4 are engaged in notches 9, the cover 4 is held securely in place.

[0061] The height and width of the ribs 11 are such that when the ribs 11 are engaged in notches 9, the recessed shape of the notches 9 are filled with the shape of the ribs 11.

[0062] The distance between the flanges 12 is such that when the cover 4 is installed on holder 3, the sides 6 are inside the flanges 12. The height of the flanges 12 is such that the cover 4 is held in place from side to side when the flanges 12 engage with the sides 6.

[0063] The curved shape of the cover 4 is the same as the curved shape of the front of the sides 6 so as to allow the cover 4 to fit securely onto the holder 3.

[0064] Description—FIG. 6—Back Prospective View Showing a Horizontal Support Assembly and End Pad.

[0065] In FIG. 6, an end pad 25 is made from a molded rubber-like material. The end pad 25 includes a tab 27 and pad 29, which are molded together in one piece. The tab 27 is smaller in dimension than the inside dimension of the end 2. The dimensions of the tab 27 are such that the tab 27 fits snugly inside the end 2 when the wide side 15 of the support assembly 1 is vertically positioned. The tab surface 28 is flat. The pad 29 is larger than the outside dimension of the end 2. The rectangular dimensions of the pad 29 are such that the pad 29 fits firmly against the end 2. The thickness of the pad 29 is such that the pad 29 withstands compression when pressed against a vertical surface. The pad surface 30 is flat.

[0066] Description—FIG. 7—Front Prospective Partial View Showing an End Pad Installation.

[0067] Now in FIG. 7, my cable management system is shown installed between to opposing vertical surfaces 44 (one pictured). The support assembly 1 has end pads 25

installed in both ends 2 (one pictured). The support assembly 1 is held in place by spring tension. One or more holder assemblies 5 are installed on the support assembly 1. The horizontal surface 45 is a support member of the vertical surface 44.

[0068] Description—FIG. 8—Back Prospective View Showing a Horizontal Support Assembly and Suction Cup.

[0069] In FIG. 8, a suction cup 26 is made from a rubber-like material. The suction cup features a tab 27, a pad 29 and a suction cup surface 31, which are molded together in one piece. The tab 27 is smaller in dimension than the inside dimension of the end 2. The dimensions of the tab 27 are such that the tab 27 fits snugly inside the end 2. The tab surface 28 is flat. The pad 29 is larger than the outside dimension of the end 2. The rectangular dimensions of the pad 29 are such that the pad 29 fits firmly against the end 2. The surface 31 is round with a concave surface facing away from the pad 29. The diameter of the surface 31 is at least twice the size of the wide side 15. The thickness of the surface 31 is such that the surface 31 can be compressed from a concave shape to a flat shape. When the surface 31 is placed on a flat plane when the surface 31 is not compressed, the edge 32 is parallel to the flat plane.

[0070] Description—FIG. 9—Front Prospective Partial View of a Suction Cup Installation.

[0071] As shown in FIG. 9, my cable management system is shown installed between two opposing vertical surfaces 44 (one pictured). The support assembly 1 has suction cups 26 installed in both ends 2 (one pictured). The support assembly 1 is held in place by spring tension and the suction cups 26. One or more holder assemblies 5 are hooked onto the support assembly 2. The horizontal surface 45 is a support member of the vertical surfaces 44.

[0072] Description—FIG. 10—Back Prospective View Showing a Horizontal Support Assembly and Top Bracket.

[0073] Now looking at FIG. 10, a top bracket 33 is made from structural materials such as wood, metal, plastic or glass. The material used will have the structural strength to support the weight of my cable management system. The top bracket 33 consists of a receptacle 34, a vertical column 35 and a base 36.

[0074] The top bracket 33 includes a receptacle 34 which allows the end 2 to be inserted horizontally inside the receptacle 34 when the wide side 15 of the support assembly 1 is vertically positioned. The dimensions of the receptacle 34 are greater than the outside dimensions of end 2 so that end 2 is held securely in place inside the receptacle 34. The receptacle is attached to the top of the vertical column 35.

[0075] The base 36 is attached perpendicularly to the bottom of the column 35. The base 36 includes at least two pilot holes 22.

[0076] Description—FIG. 11—Front Prospective Partial View Showing a Top Bracket Installation.

[0077] Now in FIG. 11, my cable management system is shown installed on a horizontal surface 45. The support assembly 1 has top brackets 33 installed in both ends 2 (one pictured). The top bracket 33 suspends the support assembly 1 above the horizontal surface 45. The height of the top bracket 33 is such that when the holder assembly 5 is

installed on the support assembly 1, the bottom edge 37 of the holder assembly 5 does not touch the horizontal surface 37. One or more holder assemblies 5 are installed on the support assembly 1.

[0078] Description—FIG. 12—Back Prospective View Showing a Horizontal Support Assembly and Side Bracket.

[0079] Now looking at FIG. 12, a side bracket 38 is made from structural materials such as wood, metal, plastic or glass. The material used will have the structural strength to support the weight of my cable management system. The side bracket 38 consists of a receptacle 34, a horizontal column 39 and a base 36.

[0080] The side bracket 38 includes a receptacle 34 which allows the end 2 to be inserted horizontally inside the receptacle 34 when the wide side 15 of the support assembly 1 is vertically positioned. The dimensions of the receptacle 34 are greater than the outside dimensions of end 2 so that end 2 is held securely in place inside the receptacle 34. The receptacle is attached to one end of the horizontal column 39.

[0081] Description—FIG. 13—Front Prospective Partial View Showing a Side Bracket Installation.

[0082] Now in FIG. 13, my cable management system is shown installed on a vertical surface 44.

[0083] The side bracket 38 suspends the support assembly 1 horizontally away from a vertical surface 44. The length of the side bracket 38 is such that when the holder assembly 5 is installed on the support assembly 1, the back 40 of the holder assembly 5 does not touch the vertical surface 44.

[0084] Description—FIG. 14—Back Prospective View Showing a Horizontal Support Assembly and Hanger Bracket.

[0085] Now looking at FIG. 14, a hanger bracket 41 is made from structural materials such as wood, metal, plastic or glass. The material used will have the structural strength to support the weight of my cable management system. The hanger bracket 41 consists of a receptacle 34, a vertical column 35 and a base 36.

[0086] The hanger bracket 41 includes a receptacle 34 which allows the end 2 to be inserted horizontally inside the receptacle 34 when the wide side 15 of the support assembly 1 is vertically positioned. The dimensions of the receptacle 34 are greater than the outside dimensions of end 2 so that end 2 is held securely in place inside the receptacle 34. The receptacle is attached to the bottom of the vertical column 35.

[0087] The base 36 is attached perpendicularly to the top of the column 35. The base 36 includes at least two pilot holes 22.

[0088] Description—FIG. 15—Front Prospective Partial View Showing a Hanger Bracket Installation.

[0089] Now in FIG. 15, my cable management system is shown installed under a horizontal surface 45. The support assembly 1 has hanger brackets 41 installed in both ends 2 (one pictured). The hanger bracket 41 suspends the support assembly 1 horizontally below a horizontal surface 45. The height of the hanger bracket 41 is such that the hook end bottom 42 clears the top side 43 when holder assembly 5 is

removed from the support assembly 1. One or more holder assemblies 5 are hooked onto the support assembly 1.

#### OPERATION OF THE INVENTION

[0090] To use my cable management system, the user must determine where the cable management system will be installed in relation to the unmanaged cables, equipment, and furniture fixtures.

[0091] The cable management system includes at least but not limited to five installation applications. Parts included for installation are end pads 25, suction cups 26, top brackets 33, side brackets 38, and hanger brackets 41. These parts install on the ends 2 of a support assembly 1. The support assembly 1 is installed on the furniture fixture near the cables and equipment. The application for each installation part is as follows:

[0092] End pads 25 are used for installation between two opposing vertical surfaces 44, such as desk sides or legs. The end pads are particularly useful when the system needs to be installed between two narrow desk or table legs. The small footprint of the end pad 25 allows for installation between legs as narrow as ½". End pads 25 are held in place by spring tension produced by the support assembly 1.

[0093] Suction cups 26 are used for installation between two opposing vertical surfaces 44, such as the sides of desks, office partitions, walls and the like. Suction cups 26 have a larger footprint than the end pad 25 and are suited for installations where the horizontal width of the vertical surfaces 44 is not limited. Suction cups 26 offer the benefit of securely holding the support assembly 1 in place where smooth or slippery surfaces may be encountered, such as glass. The increased holding ability is due to the suction cup's 26 ability to bind to the vertical surface 44 when the suction cup 26 is compressed. The suction cups 26 are held in place by both spring tension produced by the support assembly 1 and the binding action of the compressed suction cup 26 upon the vertical surface 44.

[0094] Top brackets 33 suspend the support assembly above a horizontal surface 45, such as a desk top, table top, shelf and the like. Top brackets 33 are installed with screws 20 on the horizontal surface 45 to securely hold them in place.

[0095] Side brackets 38 suspend the support assembly 1 off the side of a vertical surface 44, such as the side of a desk, cabinet, wall and the like. Side brackets are installed on the vertical surface 44 with screws 20 to securely hold them in place.

[0096] Hanger brackets 41 are used to suspend the support assembly 1 under a horizontal surface 45, such as under a desk top, table top, shelf and the like. Hanger brackets 41 are installed on the underside of the horizontal surface 45 using screws 20 to securely hold them in place.

[0097] The user decides where to install the system based on available space near the equipment and unmanaged cable. The criteria used to determine the location of the system includes the structure of the fixtures, available space, accessibility, protectability, the location of walls, walkways, and other fixtures.

[0098] Before the installation begins, the user assembles the support assembly 1. With both slots 16 facing in the same

direction, the user inserts the stop end 23 of the inner channel 14 into the slider end 24 of the outer channel 13. The tension spring 17 is placed inside the outer channel 13 and contacts the stop end 23 of the inner channel 14. The inner bracket 18 is held in the hand and the outer bracket 19 is placed on top of the inner bracket 18. The pilot hole 22 of the outer bracket 19 is lined up with the threaded hole 21 of the inner bracket 18. The screw 20 is inserted through the pilot hole 22 and screwed into the threaded hole 21 until the threads start to engage. The outer bracket 19 is moved toward the head of the screw 20 so there is a space between the inner bracket 18 and the outer bracket 19. The end 2 of the outer channel 13 is inserted into the space so that the screw 20 faces outward. The inner brackets 18, the outer bracket 19 and screw 20 are moved along the slot 16 until the inner bracket 18 contacts the end of the tension spring 17. The screw 20 is tightened so as to draw the inner bracket 18 and the outer bracket 19 together, thus binding the brackets 18 and 19 on the edges of the slot 16.

[0099] Once the support assembly 1 has been assembled and the installation location has been established, the position of the support assembly 1 is determined.

[0100] If the installation is between vertical surfaces 44 that are narrow, end pads 25 are installed on each end 2 of the support assembly 1. If the installation is between two opposing vertical surfaces 44 that are not narrow, end pads 25 or suction cups 26 are installed on each end 2 of the support rod 1. This is achieved by inserting the tab 27 into the end 2 until the end 2 contacts the pad 29.

[0101] For all installations, first loosen the screw 20.

[0102] To install the support assembly 1 with either end pads 25 or suction cups 26, hold the support assembly 1 in the position desired and slide the inner channel 14 and the outer channel 13 back and forth until the end pads 25 or suction cups 26 are slightly further apart than the two opposing vertical surfaces 44. Holding the inner channel 14 and outer channel 13 together, slide the spring 17, brackets 18 and 19 and screw 20 along the slot 16 until the spring 17 contacts the stop end 22. Tighten the screw 20.

[0103] Now holding the inner channel 14 in one hand and the outer channel 13 in the other hand, pull the channels 13 and 14 together until the end pads 25 or suction cups 26 are closer together than the two opposing surfaces 44. Move the support assembly 1 into the desired position and release the hand grip. The compressed spring tension will expand the length of the support assembly 1 and the end pads 25 or suction cups 26 will contact the surfaces 44. If the support assembly 1 is not securely held in place, repeat the installation while adjusting the location of the stop end 23 using the screw 20 until the support assembly 1 is held securely in place. Move the ends 2 around on the vertical surface 44 one at a time until the desired installation location is achieved.

[0104] In order to install top brackets 33, side brackets 38 and hanger brackets 41, select the desired installation location on either a horizontal surface 45 or vertical surface 44. Determine the length of the support assembly 1 by loosening the screw 20 and adjusting the length by sliding the channels 13 and 14 back and forth until the desired length is achieved. Holding the inner channel 14 and outer channel 13 together, slide the spring 17, brackets 18 and 19 and screw 20 along the slot 16 until the spring 17 contacts the stop end 23. Tighten the screw 20.

[0105] Now install either top brackets **33**, side brackets **38** or hanger brackets **41**, depending on application, on each end **2** of the support assembly **1**. The brackets **33**, **38** or **41** are installed by sliding the receptacle **34** over the end **2** until the end **2** contacts the back of the receptacle **34**. Locate the base **36** of each bracket **33**, **38** or **41** in the desired position and mark the position on the surface **44** or **45**. Remove the brackets **33**, **38**, or **41** from the support assembly **1** and install both bases **36**. This installation is achieved by installing the base **36** in the marked location using screws **20** through the pilot holes **22**, thus attaching the base **36** to surfaces **44** or **45**.

[0106] Install the support assembly **1** with the slots **16** toward the back. Hold the channels **13** and **14** with each hand and insert one end **2** into one receptacle **34**. Now compress the spring **17** by pulling the two channels **13** and **14** together. While the spring **17** is compressed, place the remained end **2** in the remaining receptacle **34** and release your hand grip. The spring tension will cause the remaining end **2** to be inserted into the remaining receptacle **34**. The support assembly **1** installation is now complete.

[0107] Generally, the holder assembly **5** is used to store the excess lengths of cable on the support assembly **1**. Each cable is individual wound around a holder **3** and a cover **4** in instead on the holder **3**. The holder **3** and the cover **4** when combined create the holder assembly **5**. The holder assembly **5** is then installed in the appropriate location along the horizontal plane of the support assembly **1**.

[0108] Generally, when facing the support assembly **1**, work from one side of the support assembly **1** to the other side. Start with the largest cables which are the most difficult to manage and work from one side to the other. One at a time, install the excess of each large cable on a holder assembly **5** and install the holder assembly **5** on the support assembly **1**. Now, working in the same direction, one side to the other, install the excess of the medium-sized cables on the holder assembly **5** and install the holder assembly **5** on support assembly **1**. Continue in the same manner, working from one side to the other, one cable at a time, until all the excess cable has been stored on the support assembly **1**.

[0109] To store cable, first select the appropriate size of holder assembly **5** for the size and length of the excess cable to be stored. Larger holder assemblies **5** are used for large cables or long lengths of medium cable. Medium-sized holder assemblies **5** are used for short lengths of large cable or for long lengths of medium or small cable. Smaller holder assemblies **5** are used for short lengths of medium cables or for small cables.

[0110] To install cables on the holder **3**, first disconnect both ends of the target cable and remove the cable from the unmanaged group of cables. Guide the loose end of the target cable under the support assembly **1**. Now, connect one end the the cable to the appropriate equipment. Select the appropriate size of holder assembly **5** for the target cable and remove the cover **4**. Grasp the holder with fingers on one side **7**. Position the holder **3** near the support assembly **1**. Now, with the free hand, wrap the cable around the holder **3** until the excess cable is stored, leaving enough excess cable to reach the cable connection of the remaining loose end. While holding the loose end in place on the holder **3**, install the cover **4**.

[0111] The cover **4** is installed by placing the top rib **11** into the top notches **9** located on the sides **7** of the holder **3**.

The cover **4** is then centered horizontally so that the flanges **12** are on the outer edges of both sides **7**. Now, the cover **4** is pressed towards the holder **3** until the lower rib **11** engages into the lower notches **9** located on the sides **7**. The cover **4** is now installed on the holder **3**, creating the holder assembly **5**.

[0112] While holding the holder assembly **5** with one hand, pass the remaining loose end of the cable under the support assembly **1** with the other hand. Move the holder assembly **5** toward the support assembly **1**. Allow the hook **8** to pass over the support assembly **1**, then down, thus engaged the hooks **8** on the support assembly **1**. Connect the loose end of the cable to the appropriate equipment. The cable is now stored on the holder assembly **5** which is installed on the support assembly **1**. Repeat this process until all excess cable is stored on holder assemblies **5** and all holder assemblies **5** are installed on the support assembly **1**.

[0113] The excess cable is now securely stored on holder assemblies **5** which are installed on the support assembly **1**. Each individual stored cable is protected by the cover **3** and sides **6** of each holder assembly **5**. The excess cable is prevented from unwinding on the holder **3** by the cover **4**, which is locked in position. The cables are now neatly organized along the horizontal plane of the support assembly **1**. While stored, excess heat from the cables is dissipated through the open area behind the cover **4** and the sides **6** of the holder assembly **5**.

[0114] Each individual cable can now be quickly identified by following either cable end from the equipment to the holder assembly **5** where it is stored.

[0115] Any one cable can now be easily removed by identifying the appropriate holder assembly **5**, disconnecting both ends of the cable from the equipment, and lifting the holder assembly **5** off the support assembly **1**.

[0116] Replacement of any single cable is easily achieved by installing the excess cable on the holder assembly **5**, installing the holder assembly **5** on the support assembly **1** and connecting the cable ends to the equipment.

[0117] Single cables can easily be moved back and forth along the horizontal plane by simply disconnecting the cable ends, removing the holder assembly **5** from the support assembly **1**, and reinstalling the holder assembly **5** in another location.

[0118] Multiple cables can be swapped back and forth by disconnecting the cables, and moving the holder assemblies **5** from one place to another. This allows equipment to be moved or reconfigured easily without having to disconnect the whole system, as would be required when the cables are unmanaged.

#### DESCRIPTION AND OPERATION OF ALTERNATIVE EMBODIMENTS

[0119] According to another embodiment of my cable management system, the holder assembly **5** is mounted above the support assembly **1**. The holder assembly **5** is located on top of the hook **8**. Thus, the user installs the holder assembly **5** on the support assembly **1** from above.

[0120] On another embodiment of my invention, the holder assembly **5** is mounted perpendicular to the support assembly **1**. The holder assembly **5** is located on the front of

the hook **8**. Thus, the user installs the holder assembly **5** on the support assembly **1** from the front.

[0121] In another embodiment of my invention, the holder assembly **5** is mounted on the support assembly **1** at an angle other than below, above or perpendicular to the support assembly **1**. The holder assembly **5** is located at an angle to the hook **8**. Thus, the user installs the holder assembly **5** at an angle to the support assembly **1**.

#### CONCLUSIONS, RAMIFICATIONS AND SCOPE

[0122] Accordingly, the reader can see that I have provided a complete system that allows the user to manage loose cables and the like by organizing, storing, protecting and supporting the cables within a uniform system.

[0123] The system allows the user to easy, quickly and simply remove any one cable without disturbing the remaining cables. This ability makes it easy to disconnect, remove or replace any single piece of equipment without having to untangle cables or disconnect the entire system.

[0124] My cable management system is quick and easy to set up. Unique mounting features allow the system to be installed on a wide variety of fixture surfaces. It is also inexpensive and simple to make.

[0125] Although the above descriptions are specific, they should not be considered as limitations on the scope of my invention, but only as examples of the preferred embodiment. Many other ramifications and variations are possible within the teaching of my invention. For example, other types of support assemblies **1** can be used, such as a fixed rod or suspended cable. Also, the support assemblies **1** could be arranged differently. Multiple support assemblies **1** could be used and arranged in many different ways. For example, multiple support assemblies **1** could be used in horizontal vertical or angular plans. Support assemblies **1** of many styles, materials and dimensions could be used. Instead of hooks **8**, the holder assemblies **5** could be connected to the support assembly **1** with other types of connectors that serve the same purpose, such as snap hooks, wire hooks, or detachable rings. Instead of hooks **8** built into the holder **8**, the hooks **8** connecting the holder assembly **5** to the support assembly **1** could be separate.

[0126] The holders **3** do not necessarily have to be round. As an example the center **7** of the holder **3** could be oval or square and the sides **6** could be rectangular or egg-shaped. The covers **4** do not necessarily have to conform to the shape of the holder **3**. For instance, the holder **3** could be square and the cover **4** could have an oval curve. The cover **4** does not necessarily have to be held on the holder **3** with ribs **11** and flanges **12**. As an example, the cover **4** could be held on the holder **3** with snaps, clips, hinges, pins, slots or grooves. The support assembly **1**, the holder **3**, and the cover **4** could be made out of a wide variety of materials, in various colors and surface textures. Therefore, the reader is requested to determine the scope of my cable management system by the appended claims and their legal equivalent, and not by the examples given.

The embodiment in which an exclusive property or privilege is claimed is defined as follows:

1. A cable management system with removable cable holders, comprising:

a horizontal support having two ends; and a cable holder including a first side and a second side, said sides further including hooks, wherein said hooks providing means to removably mount said cable holder on said horizontal support; and a cable holder cover.

2. A cable management system as recited on claim 1, wherein said horizontal support further including a plurality of elongated telescoping channels providing means to slidably adjust the length of said horizontal support.

3. A cable management system as recited in claim 2, wherein said telescoping channels further including an elongated slot providing means to removably attach a stop bracket to the inside of said elongated slot.

4. A cable management system as recited in claim 3, wherein said stop bracket providing means to fixably set a minimum length of said horizontal support.

5. A cable management system as recited in claim 4, wherein said telescoping channels further including a spring providing means to push said ends of said horizontal support outward against opposing surfaces.

6. A cable management system as recited in claim 1, wherein said cable holder has a first side and a second side connectably attached to a center.

7. A cable management system as recited in claim 1, wherein said sides are connectably attached to said hooks.

8. A cable management system as recited in claim 1, wherein said hooks providing means to removably attach said cable holder to said horizontal support.

9. A cable management system as recited in claim 1, wherein said cable holder further including notches.

10. A cable management system as recited in claim 9, wherein said notches providing means for removably attaching said cable holder cover.

11. A cable management system as recited in claim 1, wherein said cable holder cover further including ribs.

12. A cable management system as recited in claim 11, wherein said ribs providing means to removably attach said cable holder cover to said cable holder.

13. A cable management system as recited in claim 1, wherein said cable holder cover includes flanges.

14. A cable management system as recited in claim 13 wherein said flanges providing means to removably attach said cable holder cover to said cable holder.

15. A cable management system as recited in claim 5, wherein said horizontal support further including end pads.

16. A cable management system as recited in claim 15, wherein said end pads are removably attached to said horizontal support ends.

17. A cable management system as recited in claim 16, whereas said end pads providing means to removably attach said horizontal support between two opposing vertical surfaces.

18. A cable management system as recited in claim 5, wherein said horizontal support further including suction cups.

19. A cable management system as recited in claim 18, wherein said suction cups are removably attached to said horizontal support ends.

**20.** A cable management system as recited in claim 19, whereas said suction cups providing means to removably attach said horizontal support between two opposing vertical surfaces.

**21.** A cable management system as recited in claim 5, wherein said horizontal support further including top brackets.

**22.** A cable management system as recited in claim 21, wherein said top brackets are removably attached to said horizontal support ends.

**23.** A cable management system as recited in claim 22, whereas said top brackets providing means to removably attach said horizontal support above a horizontal surface.

**24.** A cable management system as recited in claim 5, wherein said horizontal support further including side brackets.

**25.** A cable management system as recited in claim 24, wherein said side brackets are removably attached to said horizontal support ends.

**26.** A cable management system as recited in claim 25, whereas said top brackets providing means to removably attach said horizontal support to a vertical surface.

**27.** A cable management system as recited in claim 5, wherein said horizontal support further including hanger brackets.

**28.** A cable management system as recited in claim 27, wherein said hanger brackets are removably attached to said horizontal support ends.

**29.** A cable management system as recited in claim 28, whereas said hanger brackets providing means to removably attach said horizontal support under a horizontal surface.

**30.** A cable management system with removable cable holders, comprising:

a horizontal support having two ends; a cable holder including a first side and a second side, said sides further including hooks; and a cable holder cover, wherein said horizontal support providing means to removably attach said cable management system to the top, side, and underside of vertical and horizontal surfaces, and between two opposing vertical surfaces.

**31.** A cable management system with removable cable holders, comprising:

a horizontal support; a cable holder; and a cable holder cover, wherein said horizontal support providing means to removably attach said cable management system to vertical and horizontal surfaces.

\* \* \* \* \*