

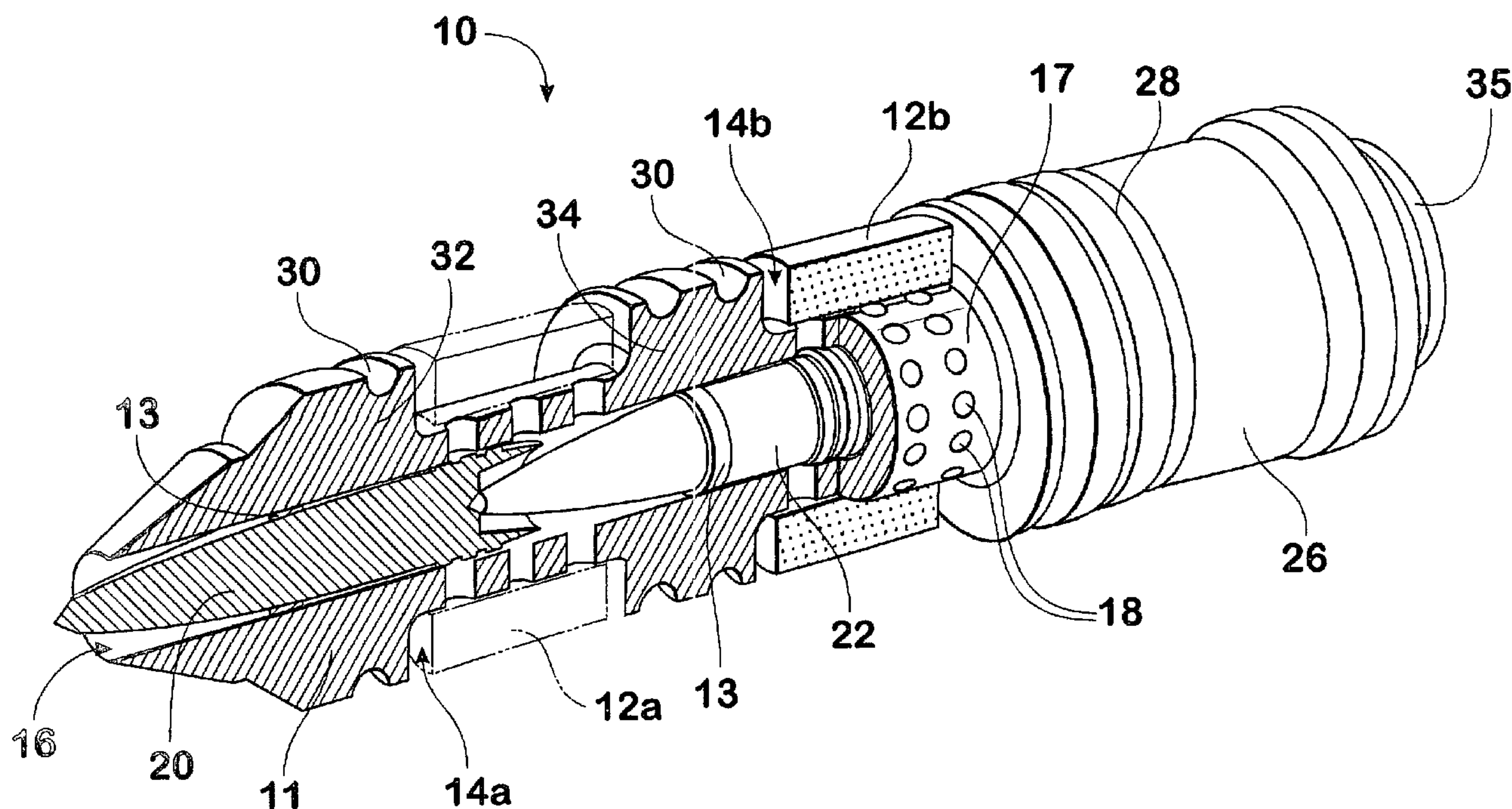

(86) Date de dépôt PCT/PCT Filing Date: 2003/06/20
 (87) Date publication PCT/PCT Publication Date: 2003/12/31
 (85) Entrée phase nationale/National Entry: 2004/12/16
 (86) N° demande PCT/PCT Application No.: AU 2003/000773
 (87) N° publication PCT/PCT Publication No.: 2004/001326
 (30) Priorité/Priority: 2002/06/20 (PS 3037) AU

(51) Cl.Int.⁷/Int.Cl.⁷ F42B 5/16, F42B 5/03
 (71) Demandeur/Applicant:
METAL STORM LIMITED, AU
 (72) Inventeurs/Inventors:
PURI, VINOD, AU;
BISHOP, BEN, AU;
O'DWYER, JAMES MICHAEL, AU;
BAMBACH, RAMON JOHN, AU
 (74) Agent: GOWLING LAFLEUR HENDERSON LLP

(54) Titre : SYSTEME DE CARTOUCHE POUR PROJECTILES MULTIPLES
 (54) Title: A CARTRIDGE ASSEMBLY FOR MULTIPLE PROJECTILES



(57) Abrégé/Abstract:

A cartridge assembly (10) for firearms or weapons, said cartridge assembly including a support body (11) having a central longitudinal channel (16) housing a plurality of projectiles (20, 22, 24) in end-to-end orientation and having a plurality of circumferential chambers (14), wherein each chamber houses (14a, 14b, 14c) at least one propellant charge (12a, 12b, 12c) and is located adjacent to a respective projectile; fluid communication means (18) included in the support body for communicating the products of a gaseous expansion of said propellant from a respective chamber (14) into said central longitudinal channel (16); whereby, upon initiation of a selected propellant charge (12a, 12b, 12c), the communicated products of gaseous expansion from a circumferential chamber force or eject a respective projectile (20, 22, 24) from the cartridge assembly (10). The propellant charges may comprise a volume of propellant material encased in a bag with an igniter.

(12) INTERNATIONAL APPLICATION PUBLISHED UNDER THE PATENT COOPERATION TREATY (PCT)

(19) World Intellectual Property
Organization
International Bureau



(43) International Publication Date
31 December 2003 (31.12.2003)

PCT

(10) International Publication Number
WO 2004/001326 A1

(51) International Patent Classification⁷: **F42B 5/16**, 5/03

John [AU/AU]; 3 Cameron Court, Victoria Point, Queensland 4165 (AU).

(21) International Application Number:

PCT/AU2003/000773

(74) Agent: **DAVIES COLLISON CAVE**; GPO Box 4387 QQ, Melbourne, VIC 3001 (AU).

(22) International Filing Date: 20 June 2003 (20.06.2003)

(25) Filing Language: English

(26) Publication Language: English

(30) Priority Data:
PS 3037 20 June 2002 (20.06.2002) AU

(81) Designated States (*national*): AE, AG, AL, AM, AT, AU, AZ, BA, BB, BG, BR, BY, BZ, CA, CH, CN, CO, CR, CU, CZ, DE, DK, DM, DZ, EC, EE, ES, FI, GB, GD, GE, GH, GM, HR, HU, ID, IL, IN, IS, JP, KE, KG, KP, KR, KZ, LC, LK, LR, LS, LT, LU, LV, MA, MD, MG, MK, MN, MW, MX, MZ, NI, NO, NZ, OM, PG, PH, PL, PT, RO, RU, SC, SD, SE, SG, SK, SL, TJ, TM, TN, TR, TT, TZ, UA, UG, US, UZ, VC, VN, YU, ZA, ZM, ZW.

(71) Applicant (*for all designated States except US*): **METAL STORM LIMITED** [AU/AU]; Level 34, 345 Queen Street, Brisbane, Queensland 4000 (AU).

(84) Designated States (*regional*): ARIPO patent (GH, GM, KE, LS, MW, MZ, SD, SL, SZ, TZ, UG, ZM, ZW), Eurasian patent (AM, AZ, BY, KG, KZ, MD, RU, TJ, TM), European patent (AT, BE, BG, CH, CY, CZ, DE, DK, EE, ES, FI, FR, GB, GR, HU, IE, IT, LU, MC, NL, PT, RO, SE, SI, SK, TR), OAPI patent (BF, BJ, CF, CG, CI, CM, GA, GN, GQ, GW, ML, MR, NE, SN, TD, TG).

(72) Inventors; and

(75) Inventors/Applicants (*for US only*): **PURI, Vinod** [AU/AU]; 9 Dickerson Way, Redwood Park, South Australia 5097 (AU). **BISHOP, Ben** [AU/AU]; 3 Kelvin Street, Nailsworth, South Australia 5083 (AU). **O'DWYER, James, Michael** [AU/AU]; Unit 112, 32 Macrossan Street, Brisbane, Queensland 4000 (AU). **BAMBACH, Ramon**,

Published:

— with international search report

[Continued on next page]

(54) Title: A CARTRIDGE ASSEMBLY FOR MULTIPLE PROJECTILES

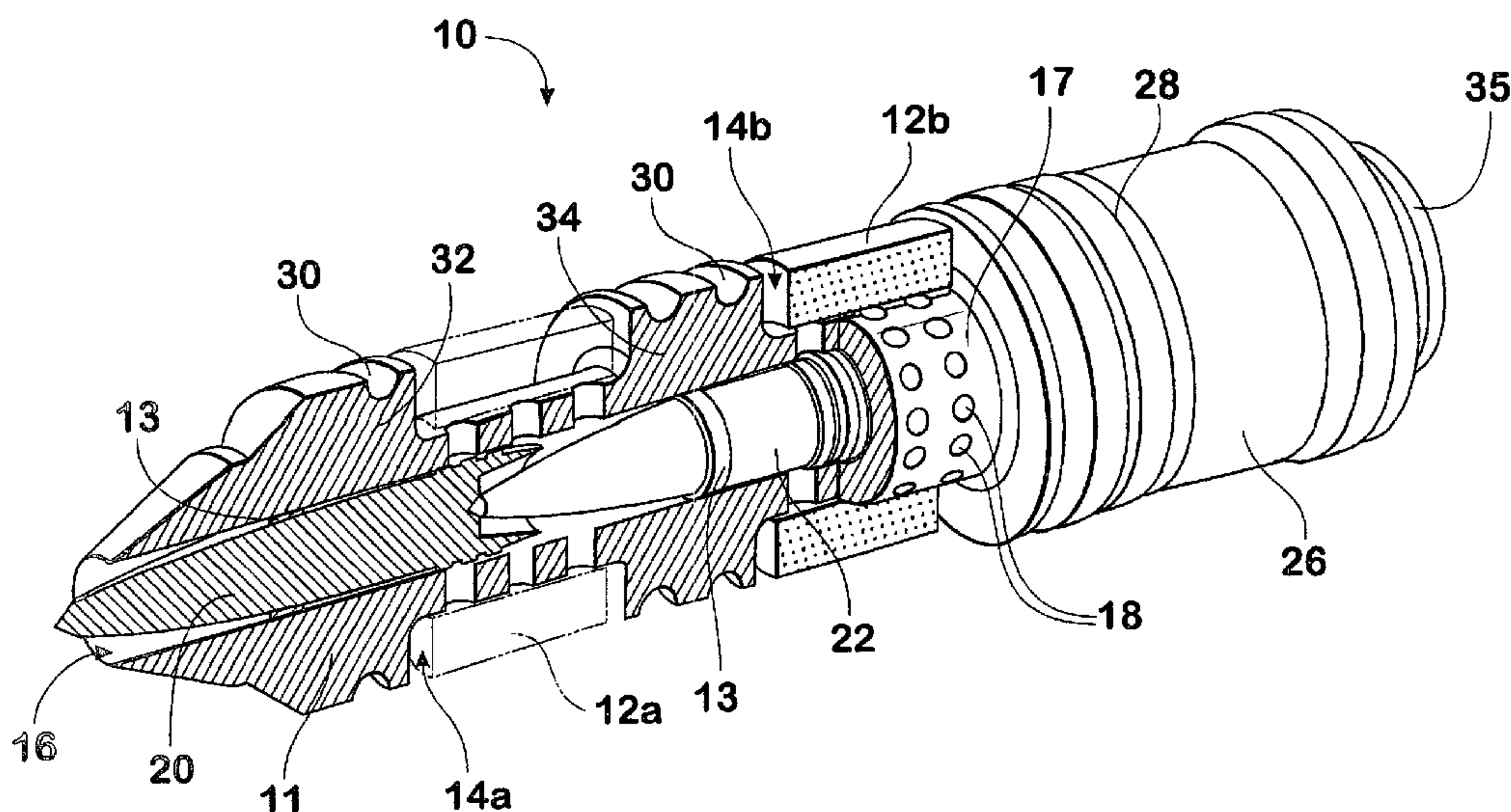

(57) Abstract: A cartridge assembly (10) for firearms or weapons, said cartridge assembly including a support body (11) having a central longitudinal channel (16) housing a plurality of projectiles (20, 22, 24) in end-to-end orientation and having a plurality of circumferential chambers (14), wherein each chamber houses (14a, 14b, 14c) at least one propellant charge (12a, 12b, 12c) and is located adjacent to a respective projectile; fluid communication means (18) included in the support body for communicating the products of a gaseous expansion of said propellant from a respective chamber (14) into said central longitudinal channel (16); whereby, upon initiation of a selected propellant charge (12a, 12b, 12c), the communicated products of gaseous expansion from a circumferential chamber force or eject a respective projectile (20, 22, 24) from the cartridge assembly (10). The propellant charges may comprise a volume of propellant material encased in a bag with an igniter.

WO 2004/001326 A1

WO 2004/001326 A1



For two-letter codes and other abbreviations, refer to the "Guidance Notes on Codes and Abbreviations" appearing at the beginning of each regular issue of the PCT Gazette.

“A CARTRIDGE ASSEMBLY FOR MULTIPLE PROJECTILES”

BACKGROUND OF THE INVENTION

5 Field of the Invention

This invention relates to cartridges for firearms or weapons. In particular, although not exclusively, the invention relates to cartridges that contain multiple projectiles for sequential ejection from the cartridge. The invention is also concerned with the disposition and initiation of propellant charges in the cartridge for projectile
10 ejection at varying kinetic energies.

Discussion of the Background Art

There exists a generally preferable need to launch projectiles at high velocity from firearms. High velocity at the muzzle end of the barrel of a firearm means that
15 whatever the weight and dimensions of the projectile, a sufficiently large gaseous expansion event has been provided behind the projectile to eject the projectile at the muzzle velocity measured.

In addition to the above well known need is the strategic and actual advantage of firing a multitude of projectiles at about the same time in the same direction. Use of
20 a firearm having such characteristics can satisfy some of the many military needs associated with direct and indirect fire weapons and firearms usage in offensive and defensive environments.

SUMMARY OF THE INVENTION

25 Object of the Invention

The invention, at least in a preferred form, seeks to provide a cartridge from which multiple projectiles can be sequentially fired at a rapid rate and at high muzzle velocity, which cartridge is useable in a variety of firearms ranging from hand-held small calibre arms to large calibre weapons.

30 Desirably, the invention may also provide a cartridge containing multiple projectiles and each projectile having an associated propellant charge that can be individually initiated in a predetermined timing arrangement to eject the associated

projectile into the barrel of a firearm at velocities that are useful in required circumstances.

Disclosure of the Invention

5 In a very broad aspect of the invention, a cartridge assembly includes a support body, the support body has a central longitudinal channel housing a plurality of projectiles in end-to-end orientation. The support body also has a plurality of circumferential chambers, each chamber houses at least one propellant charge and is located adjacent to a respective projectile. The support body further includes fluid
10 communication means for communicating the products of a gaseous expansion of said propellant from a respective chamber into said central longitudinal channel. The communicated products of gaseous expansion from a circumferential chamber thus force or eject a respective projectile from the cartridge assembly.

Fluid communication means is preferably provided by a plurality of apertures
15 included in said support body, suitably in a tubular wall portion thereof.

Most preferably, the propellant charges are sealed or encased in their respective chambers. The propellant charges may be sealed by providing obturation means for said plurality of apertures, which obturation means may be adapted to be expelled upon initiation of said propellant charge. The obturation means may
20 comprise plug members seated with the apertures or an adhesive tape wrapped about the support body and over said apertures. Suitably the adhesive tape includes aluminium foil.

Alternatively said propellant charges may be encased in a bag formed, for example, by a metallic foil.

25 If required, each of the plurality of projectiles is disposed in abutting end-to-end orientation within the channel.

Preferably the support body of the cartridge assembly is unitary and may be substantially cylindrical in shape.

30 In another broad aspect of the invention a cartridge assembly includes a unitary support body, the support body has a central longitudinal channel housing two or more projectiles in abutting end to end orientation. The support body also has

two or more circumferential chambers located adjacent a respective projectile. Each chamber houses a propellant charge and the support body further has two or more apertures for communicating the products of a gaseous expansion of said propellant from a respective chamber into said central longitudinal channel. The communicated
5 products of gaseous expansion from a circumferential chamber thus force a respective projectile from the cartridge assembly.

Preferably, the outer shape of the support body of the cartridge assembly is cylindrical.

10 In yet another aspect of the invention the support body may have transverse annular walls forming ends of said circumferential chambers. The tubular wall portion of the support body which wall is otherwise a barrier between the inside of a chamber and the central longitudinal channel, suitably has said plurality of apertures therein.

15 A cylindrical cover is suitably arranged about the outer periphery of the substantially cylindrical support body to close off the radially outward opening of the circumferential chambers. Alternatively, the circumferential chambers may be closed off by an outer wall integrally formed with the support body.

20 The cover or outer wall is adapted to form, in use, a containment barrier to the products of gaseous expansion of propellant, whereby the only path of escape from the chamber is through said apertures in the tubular wall between the chamber and the central longitudinal channel.

25 In a further aspect of the invention, there is provided a cartridge assembly including a support body having a central longitudinal channel housing a plurality of projectiles in end-to-end orientation and having a plurality of circumferential chambers, wherein each chamber houses several propellant charges and is located adjacent to a respective projectile; a plurality of sub-chambers formed in each circumferential chamber for accommodating a respective propellant charge of said
30 several propellant charges; and fluid communication means included in the support body for communicating the products of a gaseous expansion of said propellant from a respective sub-chamber into said central longitudinal channel.

BRIEF DETAILS OF THE DRAWINGS

Specific embodiments of the invention will now be described in some further detail with reference to and as illustrated in the accompanying drawing figures. The described embodiments are illustrative, and not meant to be restrictive of the scope of the invention. Suggestions and descriptions of other embodiments may be included within the scope of the invention but they may not be illustrated in the accompanying figures or alternatively features of the invention may be shown in the figures but not described in the specification. The drawings of the embodiments are as follows:

10 FIG. 1 depicts a cross-sectional side view of a cartridge assembly of a first embodiment of the invention, containing three projectiles and propellant charges;

FIG. 2 depicts a partially cut-away and phantom perspective view of the cartridge assembly of the first embodiment;

15 FIG. 3 depicts a perspective view of the exterior of a jacketed cartridge assembly;

FIG. 4 depicts a cross-sectional side view of a cartridge assembly of a second embodiment of the invention, containing a single projectile and three propellant charges;

20 FIG. 5 depicts a cross-sectional side view of a cartridge assembly of a third embodiment of the invention, containing two projectiles;

FIG. 6 depicts a top plan view of the cartridge of the third embodiment, with the projectiles and a forward propellant charge removed;

FIG. 7 depicts a cross-sectional view of the cartridge assembly of the third embodiment partially loaded into the breech of a firearm;

25 FIG. 8 depicts a cross-sectional view of the firearm of FIG. 7, with the cartridge assembly fully engaged in the breech;

FIG. 9 depicts an enlarged cross-sectional view of an aperture of a cartridge support body containing an obturation plug; and

30 FIG. 10 depicts a cross-sectional end view of a cartridge support body, including sector portions of propellant charge.

DESCRIPTION OF EMBODIMENTS OF THE INVENTION

FIG. 1 shows a cross-sectional view of a longitudinal aspect of a cartridge assembly 10 of one embodiment of the invention. This view shows a support body 11 of a substantially cylindrical configuration which partially defines a plurality of circumferential chambers 14, each chamber 14a, 14b, 14c containing a respective propellant charge 12a, 12b, 12c. The body 11 is preferably made of metal, but may be of any suitable material that can maintain rigidity under the influence of forces related to the rapid expansion of gases associated with the initiation or ignition of a propellant charge 12. A tubular wall portion of the support body also defines, at an inner surface thereof, a central longitudinal channel 16. Those expanding gases may be communicated from a chamber 14 into the central longitudinal channel 16 via fluid communication means, here in the form of a plurality of apertures 18 provided in the tubular wall portion 17 of the support body 11.

Three (3) projectiles 20, 22 and 24 are located in head to tail or stacked in abutting end-to-end orientation within the central longitudinal channel 16, wherein each projectile is located adjacent a respective chamber 14, i.e. projectile 20 is adjacent chamber 14a, projectile 22 is adjacent chamber 14b and projectile 24 is adjacent chamber 14c. Most suitably the head to tail abutments of the stacked projectiles are located adjacent the respective apertures 18 communicating between the channel 16 and the respective chambers 14.

The projectiles are, as stated, located head to tail, wherein such an arrangement keeps the length of the cartridge to a minimum. Assistance in keeping the projectiles coaxially aligned within the central channel 16 of the support body 11 so that they will be ready for firing into the also coaxially aligned barrel is not a necessity. Thus it is merely preferable that this alignment be maintained during transport and storage and up to its time of firing. In order to provide an alignment means, a small concave indent 15 is suitably provided centrally on a rear surface of each projectile into which the apex of the head of the projectile is located in abutting relation.

Yet further means of alignment can be provided by a burster disc (not shown) enclosing the entire nose of the projectile or by an annular stabilising ring 13 located on the outer surface of each projectile, forward of its middle and abutting the surface

of the central channel 16 (as shown in FIG 1). The stabilising ring might also be further adapted for sealing against the inner wall of the central channel to aid in resisting blow-by of expanding gases which might contribute to sympathetic initiation of rearward propellant charges.

5 The projectiles, such as frontmost projectile 20, also include a trailing hollow or recessed frusto-conical shaped tail portion 20t which does not touch the outer surface of the head 22h of a following projectile 22. The tail portion 20t is provided for minimising turbulence and stabilisation during flight of the projectile 20.

10 In this first embodiment, a cylindrical sleeve 26 forms a radially outermost wall of the chambers 14a, 14b and 14c. The sleeve is made of metal and is suitable for mechanical fixing to the support body fore and aft of each the chambers. FIG. 1 illustrates one way in which the sleeve can be adapted to both firmly encapsulate the support body 11 and to serve as a chamber-forming element. The sleeve 26 forms the outer wall of the chamber spaces 14.

15 In order to provide a gas tight seal, referred to as the primary seal of the arrangement (as will be discussed later) the sleeve 26 is crimped 28 into annular grooves 30 which are provided in the radially outer surfaces of the annular wall portions fore 32 and aft 34 of the chamber 14a. The crimping technique is ideally also used, fore and aft of each of the chambers, including 14b and 14c. However, it is likely that a single crimp between chambers will suffice because the cartridge itself, during use in a firearm, is surrounded and supported by a breech or similar structure (not shown). In an alternative arrangement, O-ring type seals may be provided between the outer faces of the annular wall portions and the cylindrical sleeve forming the outer wall in order to seal the propellant chambers.

25 The breech of the firearm will be specifically shaped and constructed so as to steady the cartridge during firing, such as described later in relation to FIGs. 7 and 8. The breech will also envelope the cylindrical walls of the cartridge assembly and assist the sleeve to resist the outward movement, particularly at the primary seals, that they will experience as a result of the rapid expansion of gases after ignition of the propellant 12 in the chamber 14 thus formed.

30 In another embodiment, not depicted, the outer wall may be integrally formed with the support body, i.e. the same metal as the support body will form the

cylindrical outer wall of the cartridge assembly. Access to the chambers for placement of the propellant is dependent on the type of propellant to be used in the cartridge. It is possible to provide a sealable aperture in the outer wall through which the propellant can be inserted into the chamber along with a suitable ignition means.

5 The ignition means has not been specifically described since it is a matter of choice dependent again on the propellant to be used in the cartridge assembly, but may include for example a primer. In one arrangement, primers for the propellant charge in each chamber may be triggered externally via sealable apertures (not shown) provided in the outer wall of the cartridge. The apertures allowed 20mm
10 “Cannon” electric primers inserted into a breech unit to fire into the propellant thereby providing ignition for the propellant as required.

Clearly different types of propellant will be chosen on the basis of a number of requirements, not the least being the forces desired to be generated by their ignition that will consequently eject a projectile at a desired velocity. Other considerations
15 include the volatility of the propellant for the conditions of use of the cartridge including storage and transportation. Yet another requirement will be its form, i.e. whether liquid, gas, gel or powder, and whether the propellant is suitable for the process of encasement in the chamber.

Electrical control of ignition is possible in a variety of ways known in the art,
20 such that as an example, all of the projectiles are ejected within a predetermined interval determined by the timing of the ignition signals sent by control apparatus. The ignition signals may be in the form of trigger pulses synchronised to be transmitted to the primers at the required time intervals. The pulses are synchronised by a master timer in the control apparatus that switches respective firing pulse output
25 circuits. The firing pulse output circuit for each primer includes a charge storage device that remains charged until the master timer generates a trigger pulse for the required firing pulse output line. The trigger pulse causes a transistor to conduct, thus closing the output circuit causing the charged output capacitor to discharge through the primer.

30 In experimental cartridge arrangements constructed for testing the invention, commercially available gun propellant 12 was encased in the chambers by obturation of the apertures 18. The obturation means comprised a couple of layers of foil tape

(not shown) wrapped around the outer surface of the tubular body portions of the support body 11 and over the apertures, ie. within each of the chambers 14. Two (2) layers of "Scotch" brand self adhesive aluminium tape having a measured thickness of 0.11 mm was employed. This tape was chosen to provide some small level of temperature and 'flash' protection, and a small level of 'shot start pressure' to ensure good propellant burn.

Such a propellant arrangement was chosen because of its ready availability and the need to determine maximum projectile velocities. Further the encased propellant was chosen to minimise the effect of premature ignition by gases that may blow back from an ignition associated with the ejection of a forwardly located projectile, even assuming the encasement method alone should not resist the blow-back pressure and temperatures.

An alternative proposed arrangement is to encase the propellant charge in a metal foil bag having an annular form to fit snugly within the annular chambers provided. The foil was folded back over the propellant such that the free ends were remote from the apertures provided in the body of the cartridge. In this bag configuration, the metal foil is self-sealed by external pressure.

The encasement of the propellant during the life of a cartridge assembly up until use may be important in certain conditions. If it is anticipated that the cartridge assembly will be stored in uncontrolled environments, such as high humidity and the propellant has hydrophilic properties, those conditions may render the propellant inoperative at the moment of required ignition, it is important to appropriately seal the propellant charges.

In most circumstances the propellant encasement method will require the propellant to burn through the tape or bag material and as such the effect of blow back pressures and even those gasses having accompanying high temperatures will be insufficient to prematurely ignite the encased propellant.

Some of the apertures 18 provided in the tubular wall portion forming the radially inner wall of the chamber are shown in cross-section in FIG. 1. However, as illustrated in FIG. 2, the apertures 18 are arrayed about or distributed over the whole of the tubular wall portion 17 in a grid like fashion. It is anticipated that some variation of the grid may be advantageous, not only in its spacing and configuration,

but also in the number of apertures and angle through the tubular wall portion. The exit of the apertures 18 into the central channel 16 is located, in this embodiment, about the rear portion or tail of a respective projectile.

After the propellant is ignited, the gases produced initially expand in all directions testing the sealing of the outer wall, i.e. sleeve 26, of the chamber 14. Those crimp seals 28 are, in the present embodiment, the primary seal resisting the relatively massive expansionary forces of the gases produced by the combustion of the propellant 12 initially and during the complete process of combustion. Even when the chambers are integrally formed in the wall of the cartridge assembly body, the cylindrical chamber 14 housing the propellant charge 12 is the primary location for that resistance.

Rapidly expanding gasses will tend to move and take a path of least resistance and the apertures 18 provide such a path. Initially the velocity of the gases escaping from the apertures will be less than will exist shortly thereafter once the propellant reaches its maximum combustion state. It is during the initial phase of the combustion process that the projectile associated, in positional terms, with the apertures from which the gases are escaping will begin its forward movement out of the cartridge and into the barrel of the firearm. The velocity of the gases escaping into the central chamber 16 through the apertures is less initially and reaches a maximum near the peak expansive phase of the propellant combustion.

As the projectile moves forward, it leaves a larger volume behind it and into that larger volume and its associated lesser pressure will quickly follow the gases expanding out of the chamber via the apertures. The projectile is thus moved at an increasing rate out of the cartridge reaching maximum velocity somewhere along the barrel before exiting the muzzle and being immediately affected by the external atmosphere during its now directed trajectory.

The rearward forces associated with gaseous expansion that moves rearward along the central channel of the cartridge are relevantly less than those associated with the forces experienced within the chamber but nonetheless are in existence. In some way the ring 13 provides resistance to the rearward passage of the gasses, but in any event the location of and the encasement of the nearest propellant charge is

such that any gasses that do pass the projectile will not prematurely initiate the propellant associated with that rearward projectile.

The rear end 35 of the cartridge assembly 10 includes a screw threaded cap or plug 36 for providing a rear wall for the central channel 16 that forms the rearmost volume for the gasses to enter prior to ejecting the last projectile 24.

FIG. 2 depicts a partial breakaway view of a cartridge assembly 10 showing the features of the chambers 14a, 14b and associated apertures 18 along with the external shape and configuration of the sleeve 26 that encases the cartridge. Like features are identified by like numerals to those associated with FIG. 1, as is also the case for FIG.3 which depicts a fully encased cartridge.

A cartridge assembly 10' of second embodiment of the present invention is depicted in FIG. 4. In this embodiment, only a single projectile 24' is loaded onto the central longitudinal channel 16 of the cartridge support body 11. The projectile 24' is aligned at its tail by a forward (projectile nose shaped) extension of the end plug 36 which locates in the concave indent 15 provided in the hollow tail portion of the projectile, whilst an annular stabilizing ring 13 encircles a forward portion of the projectile.

In operation, the propellant charge 12c in the cavity 14c adjacent the tail of the projectile 24' is initiated first. Then, as described above, projectile is caused to travel forward along the channel by force exerted on the projectile 24' by the expanding gasses. Upon the projectile reaching a position adjacent the second cavity 14b, such as may be exemplified by reference to projectile 22 in the first embodiment (see FIG. 1), the second propellant charge 14b is initiated. This will add to the forces acting upon the moving projectile 24', with a similar initiation of the third propellant charge 14a occurring when the projectile 24' is adjacent the third and last cavity 14a.

The result is a projectile 24' that has a higher muzzle velocity and kinetic energy that is not only higher than that employing a single similar propellant charge, but which is adjustable in a number of discrete steps. For example, an intermediate muzzle velocity is available by firing only two (2) of the three available propellant charges 14a, 14b and 14c. The remaining charge can, in this scenario, be expended

for safety reasons shortly after the projectile 24' has exited the barrel of the firing weapon.

This selection of projectile energy provides added flexibility to operation of the cartridge assembly 10'. A cartridge of this type will find application in cartridges
5 employed in relatively high pressure firearms and weapons applications, usually where high velocity projectiles are required such as in sniper rifles, ship defence weapons and armour piecing rounds for anti-armour use.

In FIGs. 5 and 6, there is shown a cartridge assembly 50 of a third
10 embodiment of the invention. The assembly includes a longitudinal support body 51 which partially defines circumferential chambers 53 for housing propellant charges 52. End walls of the circumferential chambers are formed by annular wall portions 54 of the support body 51, which wall portions extend outwardly from a tubular wall portion 55 of the support body. The tubular wall portion 55 defines, at an inner
15 surface thereof, a central longitudinal channel 56 in which is located projectiles 60. The rear or breech end of the channel 56 is closed by a screw threaded cap 59, which includes support structure for the rearmost projectile 60b. The tubular body 55 further includes a plurality of fluid communication means, in the form of ports 58, for communicating expanding gasses from the respective chambers 53 when a
20 propellant charge 52 is initiated.

In the present embodiment, each propellant charge 52 includes a volume of propellant material 61 encased in a bag 62, suitably constructed of materials including a metallic foil. The bags have the desirable property of being resistant to
25 external impingement by expanding gases, whilst readily bursting upon initiation of the propellant material 61 by an igniter 63 disposed within the bag 62. The bags 62 are suitably disposed in a respective circumferential chamber, being wrapped around the tubular wall portion 55 including the longitudinal arrays of ports 58. It will be noted that the forward propellant charge 52a has been omitted from the external view of the cartridge assembly shown in FIG. 6, for reasons of clarity.

30 A breech end of a firearm 70 for receiving a cartridge assembly is depicted in FIGs. 7 and 8. The firearm 70 includes a breech chamber 71 and a barrel 72, of which only a fragment is shown, having a bore 73. Whilst there will be several

different methods for loading the cartridge assembly 50 into the breech chamber of firearms for coaxial alignment with the barrel of the firearm (including side loading), a rear loading arrangement is depicted in the drawings.

The breech chamber includes at a forward end, a tapered surface 74 for engagement with the tapered nose portion of the support body 51 of the cartridge assembly 50. The tubular internal wall 75 of the breech chamber 71 is also sized to closely envelope and support the outer circumference of the cartridge assembly 50. The cartridge assembly 50 is, after full insertion as depicted in FIG. 8, then sealed inside the breech chamber 71. A hinged door 76 is attached to the rear of the firearm 70 utilising a cammed hinge arrangement (not shown), such that the door 76 can open on a hinge to allow insertion of a fresh cartridge assembly and retraction of a spent cartridge assembly

A further arrangement to minimise the effect of gases that may blow back from an ignition associated with the ejection of a forwardly located projectile is depicted in FIG. 9. In this arrangement, further sealing of the propellant chamber containing a propellant charge 12 is provided by obturation means in the form of a frusto-conical shaped plug 38 that is wedged into correspondingly shaped apertures 18' provided in the tubular wall portion of the support body 11. The plugs 38 are each arranged to enhance the seal in the aperture 18' when exposed to gas pressure external of the propellant chamber, i.e. coming from within the central channel containing the projectiles (not shown). However, when exposed to pressure from within the propellant chamber, generated by the initiated propellant charge 12, the plug 38 will be expelled from the aperture. The plugs 38 are suitably composed of a material that is consumed by burning propellant, such that minimal residue from the plugs remains in the cartridge or in the barrel of a firearm. Suitably the surface of the plugs exposed to the central channel may be coated with a combustion resistant material.

In order to provide each projectile with more than one propellant volume, the circumferentially disposed propellant volume of the embodiments described above (which is completely wrapped around the tubular wall portion of the cartridge support body) is broken into smaller propellant sections. If three (3) separate propellant volumes are desired then the propellant chamber is divided into three smaller sub-chambers, each utilising around 120 degrees of the available original circumferential

chamber. This modification is depicted in the cross-sectional end view of the cartridge 80 depicted in FIG. 10.

The cartridge support body 81 includes three (3) propellant sub-chambers 83, 84, 85 formed by radially extending side walls 82 that divide the circumferential chamber into three (3) sectors. Each sub-chamber contains a smaller propellant charge 90, comprising a propellant volume 91 and associated igniter 92 encased in an individual bag 93. The sub-chambers each communicate with the central channel 86 via a longitudinal array of apertures or ports 88 provided in the tubular wall portion 87 of the support body 81.

Where each of the three (3) smaller propellant charges 90 is provided with a separate primer, a firing control computer can determine how many propellant volumes are to be initiated depending on the desired ballistic solution and the kinetic energy thus required. The smaller charges may be fired together, or in a staggered sequence as discussed above in relation to the second embodiment of the invention.

If required, any unused propellant charges associated with forward projectiles could be employed as travelling charges for later fired rearward projectiles.

A variety of materials could be used for constructing the cartridge assembly of the invention, other than metal. For example a re-load cartridge could be made of a lightweight composite material and simply discarded after use. The propellant bags and sealing plugs could also be constructed of composite or suitable materials other than metallic foils.

It is anticipated that sabot technology will provide for further increases in velocities of projectiles.

It is further anticipated that a cartridge assembly according to the invention can be made of dimensions to suit almost any size of projectile suitable for firing through a suitably proportioned barrel of a firearm. That is, projectiles of .22 calibre or projectiles referred to as 80mm rounds can be accommodated in a cartridge assembly by suitably scaling the relevant elements of the invention. Clearly the cartridge feed mechanisms of respective firearms will need modification to accommodate the generally longer, radially larger and heavier cartridges.

The calibre of firearms and projectiles is expressed in various ways. Cannons are often designated by the weight of a solid spherical shot that will fit the bore, for

example a 12-pounder. Pieces of ordnance that project a shell or hollow shot are designated by the diameter of their bore, e.g. a 12 inch mortar or a 14 inch shell gun. Small arms are designated by hundredths of an inch expressed decimally, such as a rifle of .44 inch calibre. In other examples the outer diameter of the projectile or the
5 inner diameter of the barrel of the firearm is referred to in millimeters or thousandths of an inch.

It will be appreciated by those skilled in the art that the invention is not restricted in its use to the particular application described. Neither is the present invention restricted in its preferred embodiment with regard to the particular elements
10 and/or features described or depicted herein. It will further be appreciated that various modifications can be made without departing from the principles of the invention. Therefore, the invention should be understood to include all such modifications within its scope as defined in the claims which follow.

15

CLAIMS

1. A cartridge assembly for firearms or weapons, said cartridge assembly including:

5 a support body having a central longitudinal channel housing a plurality of projectiles in end-to-end orientation and having a plurality of circumferential chambers, wherein each chamber houses at least one propellant charge and is located adjacent to a respective projectile;

10 fluid communication means included in the support body for communicating the products of a gaseous expansion of said propellant from a respective chamber into said central longitudinal channel;

whereby, upon initiation of a selected propellant charge, the communicated products of gaseous expansion from a circumferential chamber force or eject a respective projectile from the cartridge assembly.

15

2. The cartridge assembly as claimed in claim 1 wherein the fluid communication means is provided by a plurality of apertures included in said support body.

20 3. The cartridge assembly of either claim 1 or claim 2 wherein the support body includes a tubular wall portion defining said central longitudinal channel

4. The cartridge assembly of claim 3 wherein said plurality of apertures are provided in the tubular wall portion of said support body.

25

5. The cartridge assembly of any one of claims 1 to 4 wherein a plurality of propellant charges and associated ignition means are disposed in each propellant chamber.

30 6. The cartridge assembly of claim 5 wherein one or more of said plurality of propellant charges may be initiated together or in a desired sequence, according to a desired muzzle velocity for the adjacent projectile.

7. The cartridge assembly of either claim 5 or claim 6 wherein said propellant chamber is divided into a plurality of sub-chambers for respective ones of said plurality of propellant charges.

5 8. The cartridge assembly of any one of claims 1 to 7 wherein the propellant charges are sealed or encased in their respective chambers.

9. The cartridge assembly of claim 8 wherein the propellant charges are sealed by providing obturation means for said plurality of apertures.

10

10. The cartridge assembly of claim 8 wherein the propellant charges comprise a volume of propellant material encased in a bag with an igniter.

11. The cartridge assembly of any preceding claim wherein the support
15 body has transverse annular walls forming ends of said circumferential chambers.

12. The cartridge assembly of claim 11 wherein said circumferential chambers are divided into a plurality of sub-chambers by radially extending side walls.

20

13. The cartridge assembly of claim 12 wherein the tubular wall portion, which is otherwise a barrier between the inside of each sub-chamber and the central longitudinal channel, has said plurality of apertures therein for each sub-chamber.

25 14. The cartridge assembly of any preceding claim further including a cover arranged about the outer periphery of the support body to close off the radially outward opening of the circumferential chambers.

30 15. The cartridge assembly of any one of claims 1 to 13 wherein the circumferential chambers are closed off by an outer wall integrally formed with the support body.

16. The cartridge assembly of either claim 14 or claim 15 wherein the cylindrical cover or outer wall, is adapted to form, in respective use, a containment barrier to the products of gaseous expansion of propellant, whereby the only path of escape from a circumferential chamber is through said apertures in the tubular wall portion between the circumferential chamber and the central longitudinal channel.

17. A cartridge assembly including a unitary support body, the support body having a central longitudinal channel housing two or more projectiles in abutting end to end orientation and having two or more circumferential chambers located adjacent a respective projectile; wherein each circumferential chamber houses a propellant charge and the support body further has two or more apertures for communicating the products of a gaseous expansion of said propellant from a respective chamber into said central longitudinal channel; whereby, in use, the communicated products of gaseous expansion from a circumferential chamber thus force a respective projectile from the cartridge assembly.

18. The cartridge assembly of claim 17 wherein the outer shape of the support body of the cartridge assembly is cylindrical.

19. The cartridge assembly of either claim 17 or claim 18 wherein the support body has transverse annular walls forming ends of said circumferential chambers.

20. The cartridge assembly of any one of claims 17 to 19 wherein a tubular wall portion of the support body which wall portion is otherwise a barrier between the inside of a chamber and the central longitudinal channel, suitably has said plurality of apertures therein.

21. The cartridge assembly of any one of claims 18 to 20 further including a cylindrical cover arranged about the outer periphery of the substantially cylindrical support body to close off the radially outward opening of the circumferential chambers.

22. The cartridge assembly of any one of claims 17 to 20 further including an outer wall, integrally formed with the support body, to close off the radially outward opening of the circumferential chambers.

5

23. The cartridge assembly of either claim 21 or claim 22, wherein the cover or outer wall is adapted to form, in respective use, a containment barrier to the products of gaseous expansion of propellant, whereby the only path of escape from the chamber is through said apertures in the tubular wall between the chamber and the central longitudinal channel.

10

24. A cartridge assembly including:

a support body having a central longitudinal channel housing a plurality of projectiles in end-to-end orientation and having a plurality of circumferential chambers, wherein each chamber houses several propellant charges and is located adjacent to a respective projectile;

15

a plurality of sub-chambers formed in each circumferential chamber for accommodating a respective propellant charge of said several propellant charges;

fluid communication means included in the support body for communicating the products of a gaseous expansion of said propellant from a respective sub-chamber into said central longitudinal channel.

20

25. The cartridge assembly of claim 24 further including a tubular wall portion of the support body for defining, at an inside surface, the central longitudinal channel.

25

26. The cartridge assembly of either claim 24 or claim 25 wherein the support body has transverse annular walls forming ends of said circumferential chambers.

30

27. The cartridge assembly of any one of claims 24 to 26 wherein the support body has radially extending side walls dividing each circumferential chamber into several sub-chambers.

5 28. The cartridge assembly of any one of claims 24 to 27 wherein each sub-chamber contains a propellant charge comprising a volume of propellant material and an igniter encased in an individual bag.

10 29. The cartridge assembly of any one of claims 25 to 28 wherein said sub-chambers each communicate with the central channel via a longitudinal array of ports provided in the tubular wall portion of the support body.

15 30. The cartridge assembly of any one of claims 24 to 29 wherein, upon initiation of a selected propellant charge, the communicated products of gaseous expansion from a circumferential chamber force or eject a respective projectile from the cartridge assembly.

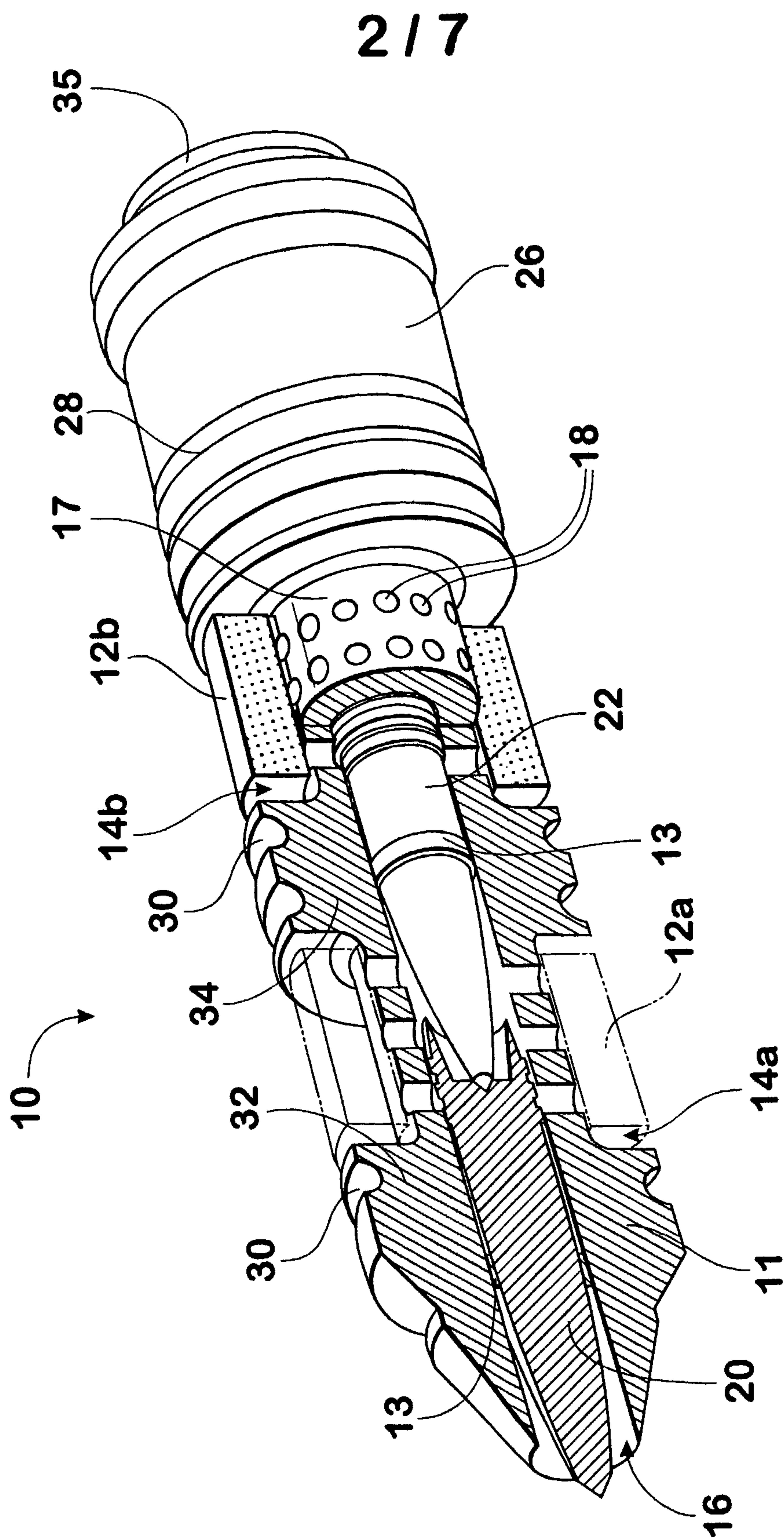

Fig. 2

3 / 7

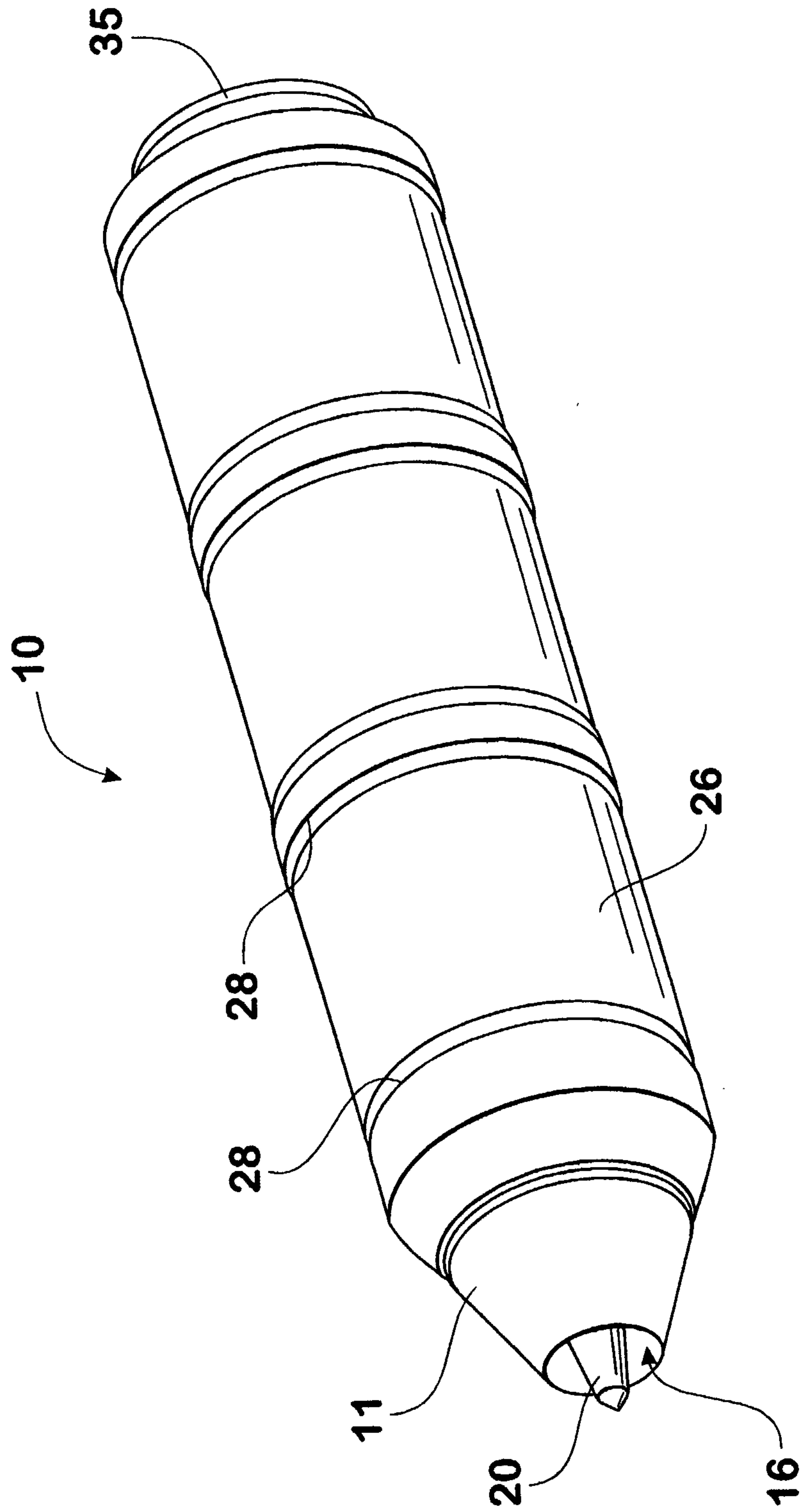

Fig. 3

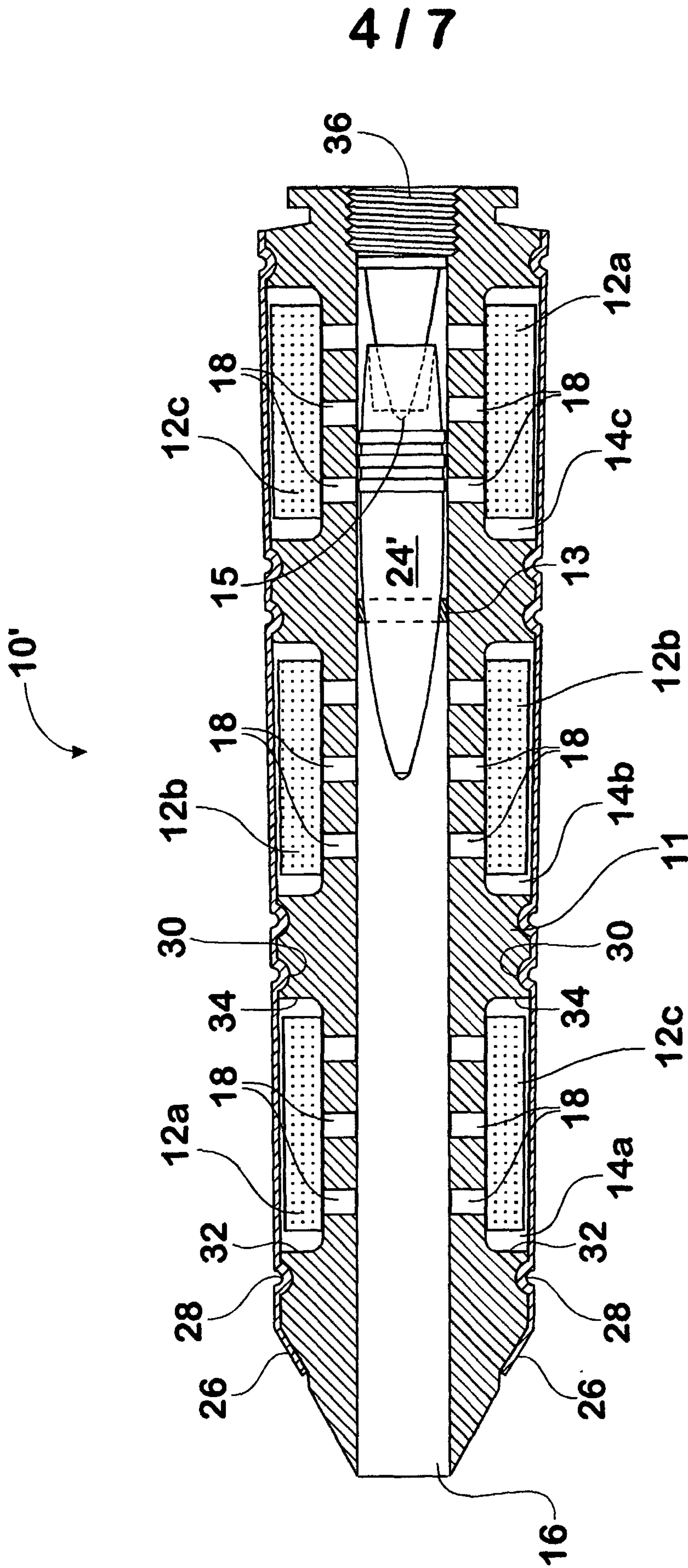

Fig. 4

6 / 7

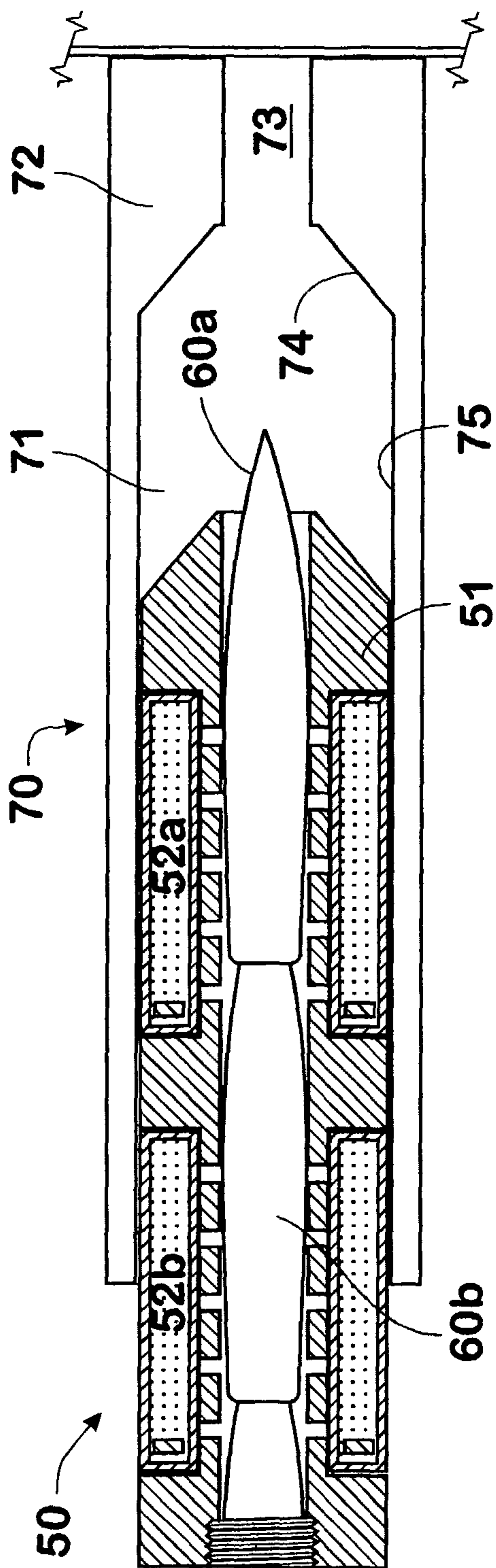

Fig. 7

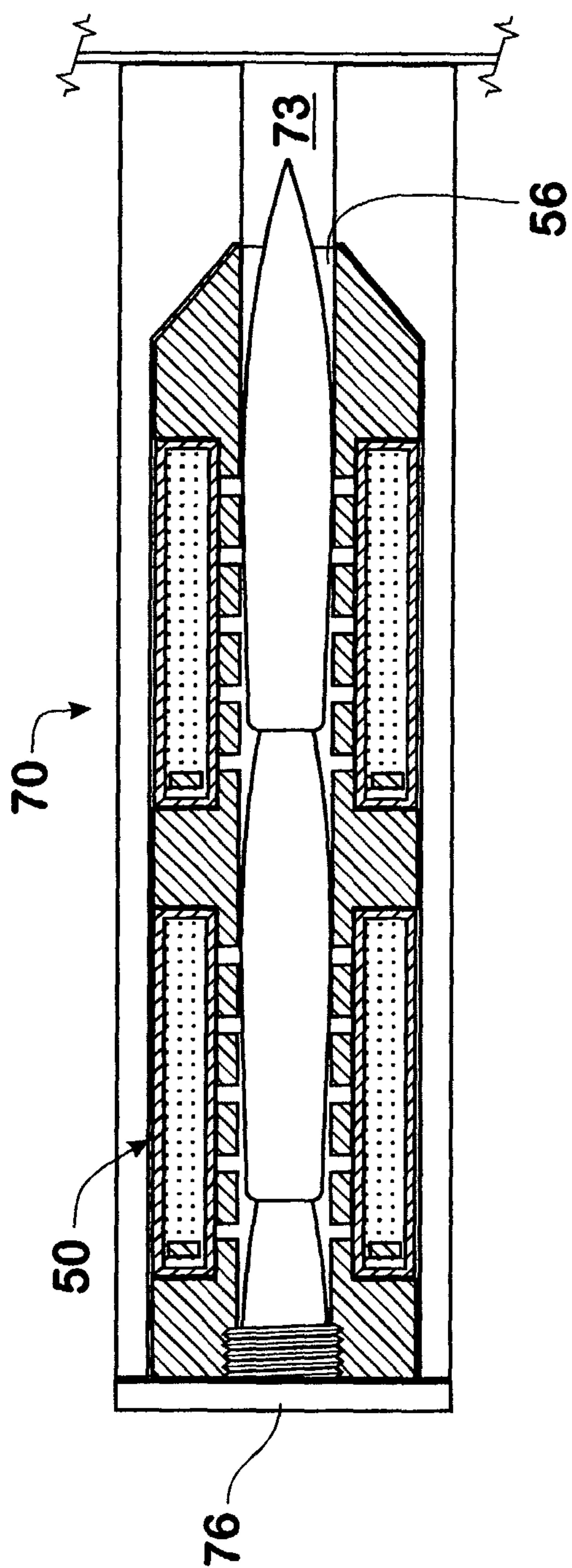

Fig. 8

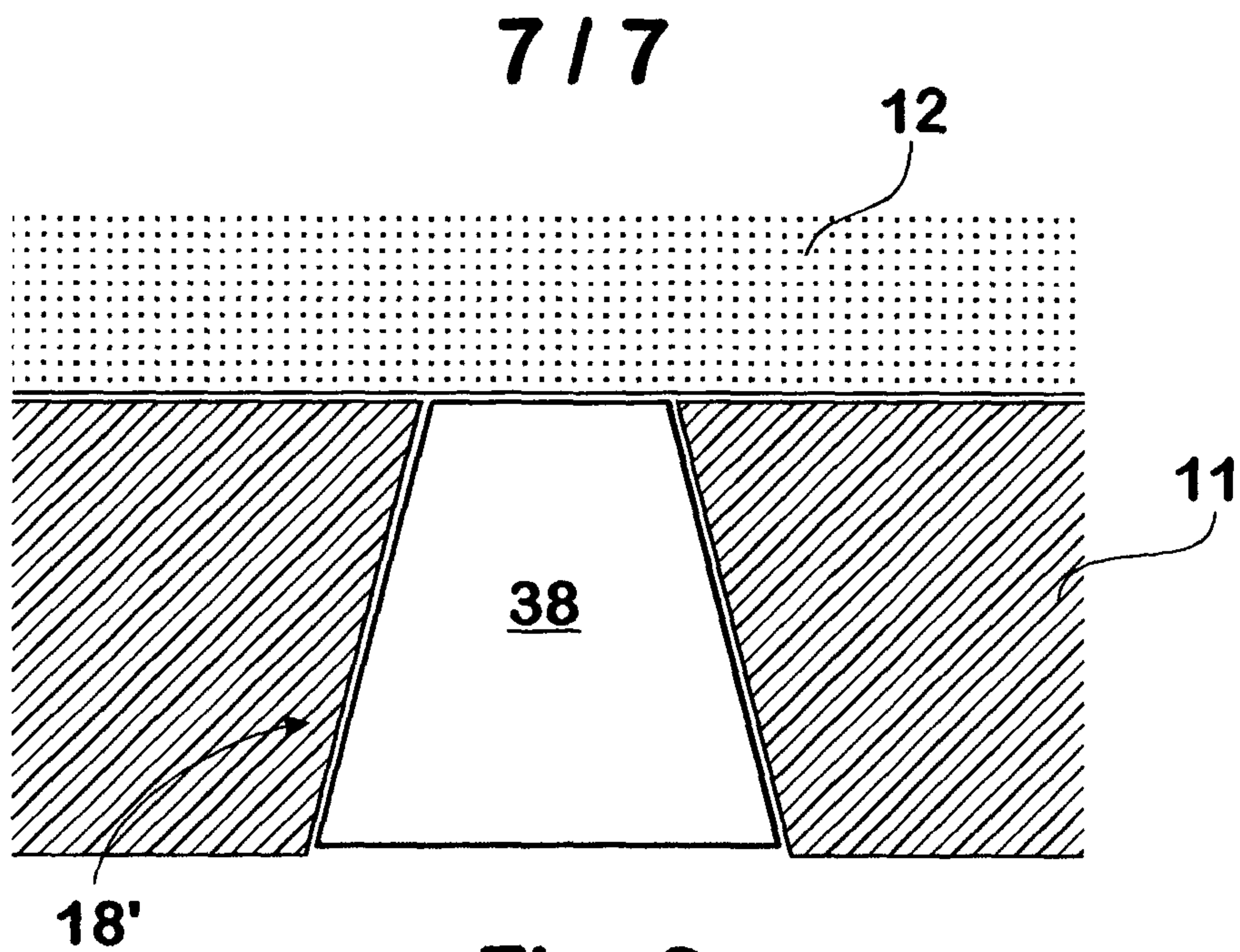

Fig. 9

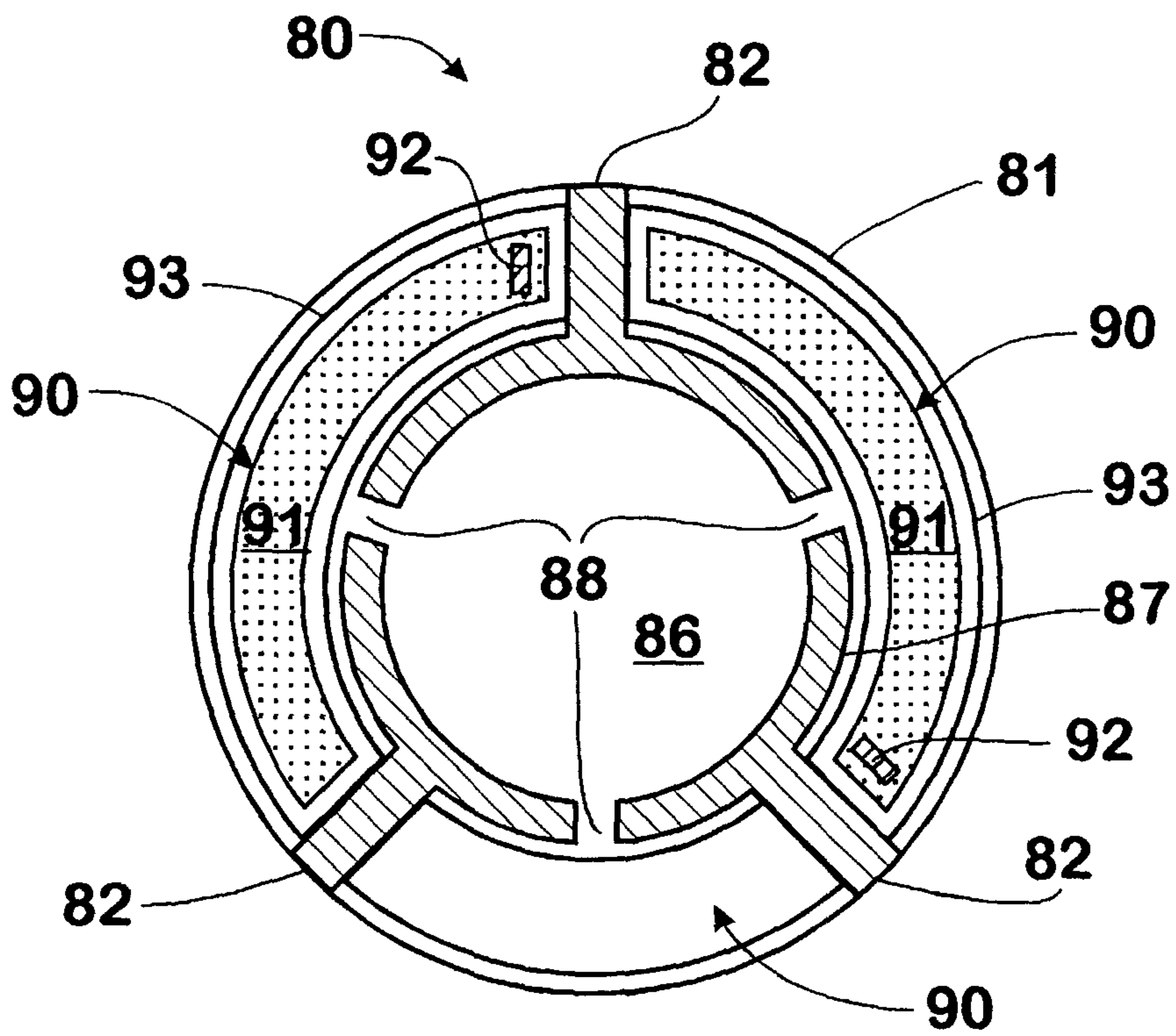

Fig. 10

