

I. B. RITTER.
SWITCH.

APPLICATION FILED JULY 8, 1903.

NO MODEL.

4 SHEETS—SHEET 1.

FIG. 1.

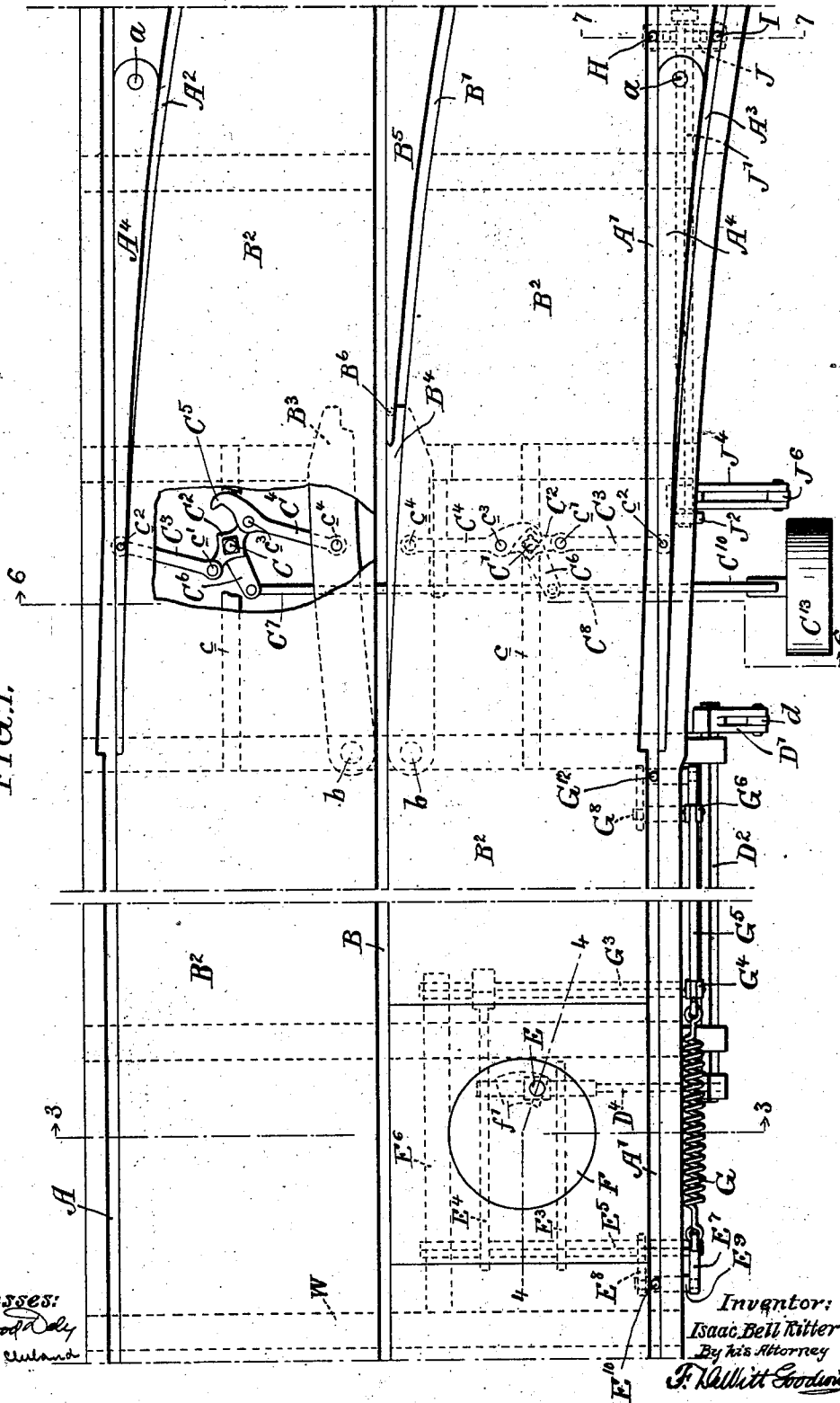

Witnesses:
Samuel Dady
Mary R. Steward

Inventor:
 Isaac Bell Ritter
 By his Attorney
J. Hallitt Gooding

I. B. RITTER.
SWITCH.

APPLICATION FILED JULY 8, 1903.

NO MODEL.

4 SHEETS—SHEET 2.

FIG. 2.

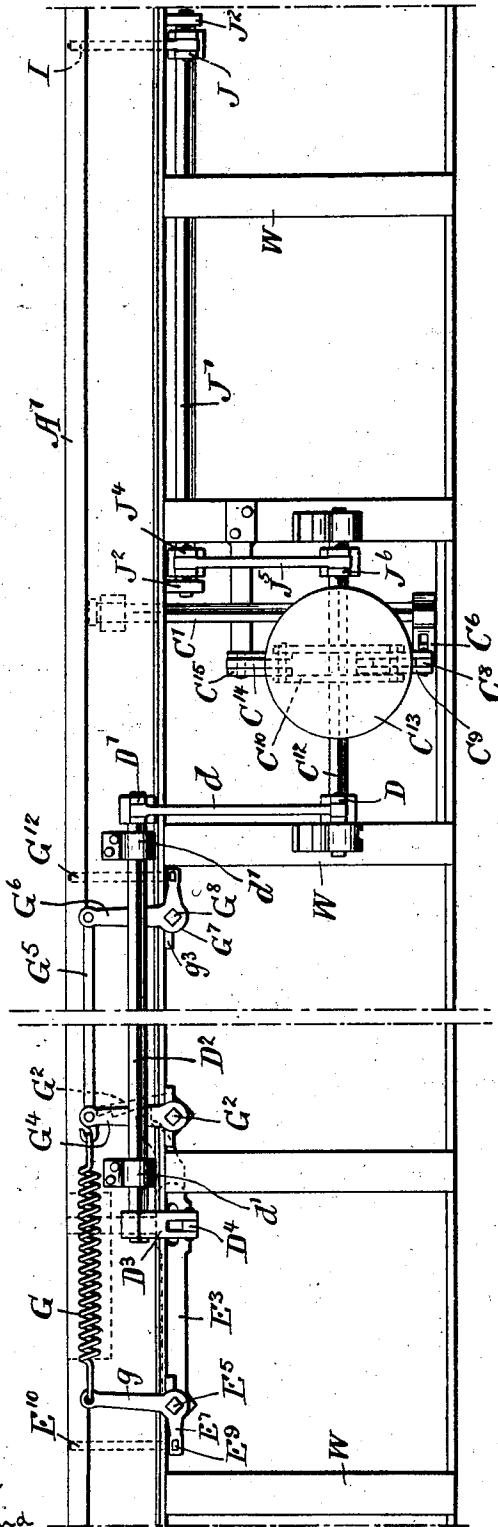

Witnesses:
J. J. Wood
Mary R. Cleland

Inventor:
 Isaac Bell Ritter
 By his Attorney
F. DeWitt Godwin

I. B. RITTER.
SWITCH.

APPLICATION FILED JULY 8, 1903.

NO MODEL.

4 SHEETS—SHEET 3.

FIG. 3.

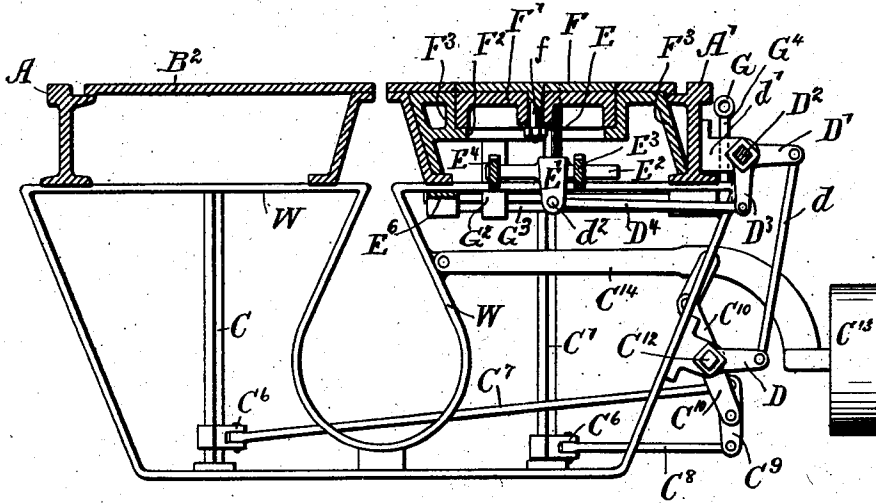

FIG. 4.

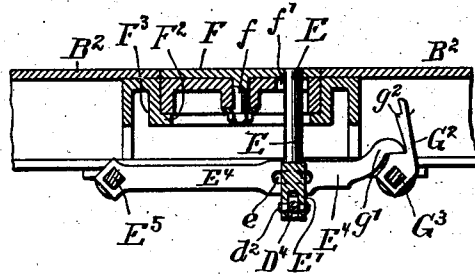
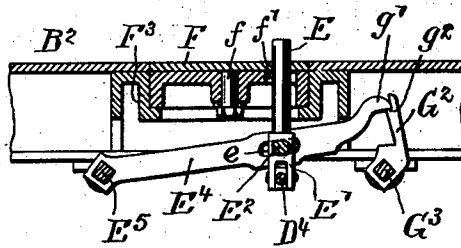

FIG. 5.



Witnesses:
Wm. Wood Daley
 Mary N. Culand

Inventor:
 Isaac Bell Ritter
 By his Attorney
F. Lowell Goodwin

I. B. RITTER.
SWITCH.

APPLICATION FILED JULY 8, 1903.

4 SHEETS—SHEET 4.

NO MODEL.

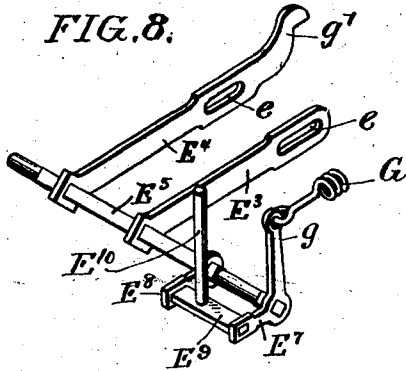
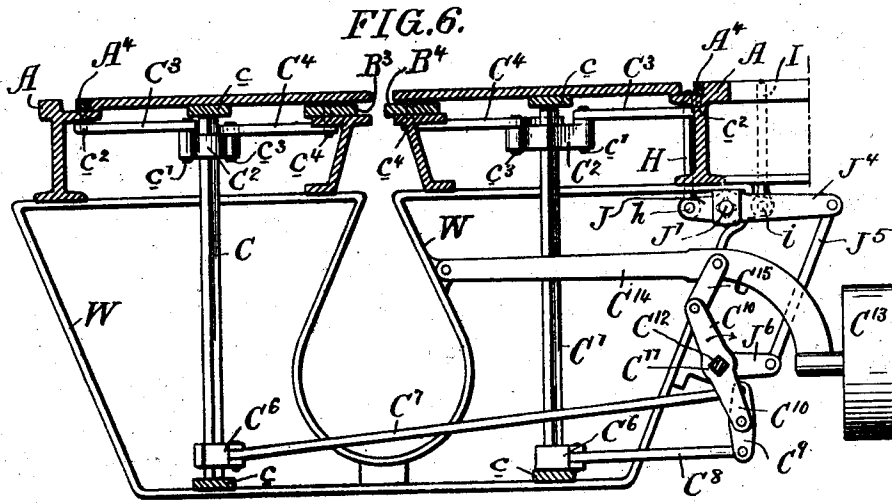

FIG. 9.

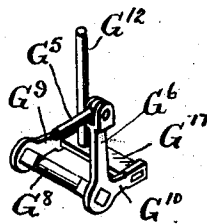
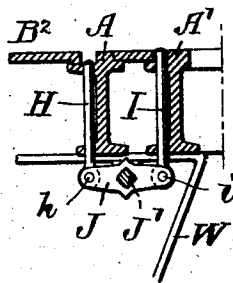

FIG. 7.



Witnesses:

J. Burnwood Daly
Mary R. Ueland

Inventor:

Isaac Bell Ritter
By his Attorney

J. D. Dillitt Goodwin

UNITED STATES PATENT OFFICE.

ISAAC BELL RITTER, OF PHILADELPHIA, PENNSYLVANIA.

SWITCH.

SPECIFICATION forming part of Letters Patent No. 747,774, dated December 22, 1903.

Application filed July 8, 1903. Serial No. 164,644. (No model.)

To all whom it may concern:

Be it known that I, ISAAC BELL RITTER, a citizen of the United States, residing at Philadelphia, in the county of Philadelphia and State of Pennsylvania, have invented certain new and useful Improvements in Switches, of which the following is a specification.

My invention relates to improvements in railway-switches, and is particularly adapted to street-railways where a central slot between the tracks is used for the depending plow carried by the cars to enter and make contact with electrical conductors or to engage a cable.

The object of my invention is to provide a switch mechanism which will control the switch-tongues and the slot switch-bars in the central slot, giving them a positive and simultaneous movement and locking the same in either position—that is to say, when the switch is opened or closed.

My invention is provided with and operated by a pin located between the tracks, which is acted upon by an automatic switch-controller carried by the car, such as that shown and described in Letters Patent for "Automatic switch-controller," No. 692,050, dated the 28th day of January, A. D. 1902.

A further object of my invention is to have the above-mentioned operating-pin concealed except when in operation. This is accomplished by the operating-pin being raised above the surface of the street by the wheel of an approaching car depressing a pin in the rail, and after the automatic switch-controller on the car shifts the switch to the desired position the car-wheel depresses a second pin, which causes the operating-pin to disappear.

A still further object of my invention is to provide a means of shifting the switch by a car coming from the opposite direction from where the central operating-pin is located. This consists of two pins, one in the main track and one in the branch track, and as the car approaches the switch the wheels will contact with the pin in that particular track and open the switch, so that the car may pass through it.

Referring to the drawings, Figure 1 illustrates a plan view of a switch, showing my

invention embodied therein. Fig. 2 is a side view of the same. Fig. 3 is a vertical sectional view on line 3 3, Fig. 1. Fig. 4 is a vertical sectional view on line 4 4, Fig. 1. Fig. 5 is a view similar to Fig. 4, showing the parts in a different position. Fig. 6 is a vertical sectional view on line 6 6, Fig. 1. Fig. 7 is a vertical sectional view on line 7 7, Fig. 1. Fig. 8 is a perspective view of the levers for operating the central operating-pin. Fig. 9 is a perspective view of one of the pins operated by the car-wheel.

In the drawings, A and A' represent the tracks on the main line, and A² and A³ represent the branch tracks.

A⁴ represents the switch-tongues, pivoted at *a*.

B represents the central groove for the plow carried by the car; B', the groove for the branch track.

B² represents plates covering the space between the tracks and central grooves to protect the operating mechanism.

B³ and B⁴ are the slot switch-bars, pivoted at *b* to the frame W.

The vertical shafts C and C', as shown in Figs. 1 and 6, are adapted to rotate in bearings *c*. On the shafts C and C' are arms C², to which are pivoted the links C³ at *c'*, and at *c''* the said links are pivoted to the switch-tongues A⁴. The said arms also have links C⁴ pivoted to them at *c''*, which said links are pivoted to the slot switch-bars B³ and B⁴ at *c''*.

The links C⁴ are provided with extensions, forming hooks C⁵, which engage the vertical shafts and prevent the shafts and links from turning too far. In Fig. 1 shaft C' is shown engaged by the hook C⁵, in which position the pivot-points *c'*, *c''*, *c''*, and *c''* are all in line with the vertical shaft C', forming a dead-center and locking the switch-tongue A⁴ and the slot switch-bar B⁴, so that they cannot be moved by any force applied directly to them.

The vertical shafts C and C' are rotated by the following means: Each is provided with an arm C⁶, and pivoted to said arms are the rods C⁷ and C⁸, as shown in Fig. 6. The said rods are pivoted at their opposite ends to a lever C⁹, which is pivoted to and carried by the lever C¹⁰, which is secured at C¹¹ to the rock-shaft C¹². It will readily be seen that

by rotating the said rock-shaft C¹² the vertical shafts will be turned and operate the switch-tongues and the slot switch-bars.

As shown in Fig. 1, the vertical shaft C' is 5 locked by the links; but the shaft C is not locked. To hold the shaft C in its proper position, a weight C¹³ is provided which acts upon the rock-shaft C¹². The weight is carried by an arm C¹⁴, pivoted to the frame W. (See Fig. 6.) 10 A link C¹⁵ connects the weight-arm and the lever C¹⁰ upon the rock-shaft C¹² and holds said rock-shaft in its proper position. When the rock-shaft C¹² is rotated in the direction of the arrow, the lever C¹⁰ raises the weight, and 15 when said lever C¹⁰ has moved the vertical shafts and the switch-tongues and slot switch-bars to the reverse position the weight will then hold them in said position.

The rock-shaft C¹² is operated in the following manner: The said rock-shaft is provided with an arm D, as shown in Figs. 2 and 3, which is connected to an arm D' on a rock-shaft D² by a rod *d*. The rock-shaft D² is 20 mounted in bearings *d'*, secured to the side of the rails A'. The said shaft is also provided with an arm D³, having pivoted thereto a rod D⁴, which is pivoted at *d*² to the lower end of the central operating-pin E, as shown in Figs. 3, 4, and 5. The pin E passes up 30 through a disk F and is operated upon by the automatic switch-controller carried by the car. Said switch-controller, which is not shown in the drawings, may be of any form, but preferably a block suspended from the car having a cam-surface the angle of which 35 may be set so as to give the pin E a motion at right angles to the tracks A and A' when the said cam is brought in contact with the pin E by the moving car. The switch-controller is adapted to be set so as to move the pin E in either direction, the effect of which being to open or close the switch. The motion received by the pin E is communicated to the rod D⁴. (Clearly shown in Fig. 3.) 45 Said rod is connected to the arm D³ on the rock-shaft D², which is connected by the arm D', the rod *d*, and the arm D to the shaft C¹². The rock-shaft C¹² communicates motion to the vertical shafts C and C' through the medium of the lever C¹⁰, the lever C⁹, carried by said lever C¹⁰ and rods C⁷ and C⁸, which are 50 connected to the said lever C⁹ and to the said vertical shafts. The said vertical shafts are each provided with arms C², which are connected to the slot switch-bars by the links C⁴ and to the switch-tongues by the links C³, thereby operating said switch-tongues and the slot switch-bars.

The disk F has a pin *f*, which is pivoted to the disk-frame F', held in the projection F² of the frame F³. The disk-frame F' is provided with an opening *f'*, the ends of which act as a stop to limit the movement of the pin E. (See Fig. 1.)

65 The pin E is provided with a head E', having arms E², which enter elongated openings *e* in the levers E³ and E⁴. (Shown in Fig. 8.)

These levers are mounted upon a shaft E⁵, which is pivoted to the track A', and a bar E⁶ on the frame W. Said shaft E⁵ is provided 70 with levers E⁷ and E⁸, having a connecting-plate E⁹, upon which rests a pin E¹⁰, which projects up through an opening in the track A'. This pin when acted upon by the car-wheel depresses the levers E⁷ and E⁸ and 75 raises the levers E³ and E⁴, which raise the pin E up above the surface of the plates B², so that it may be engaged by the car. A spring G acts upon an arm *g* on the shaft E⁵ and tends to depress the levers E³ and E⁴, 80 carrying the pin E. To hold the pin up against the action of said spring, I provide an extension *g'* on the lever E⁴, which is engaged, as shown in Figs. 4 and 5, by a projection *g*² on an arm G² on the shaft G³, pivoted in bearings 85 in the track A' and the bar E⁶. An arm G⁴, Fig. 2, on said shaft is engaged by the spring G, which tends to hold the arm G² in engagement with the lever E⁴. A rod G⁵ is also pivoted to said arm G⁴, and at its opposite end it 90 is pivoted to an arm G⁶ of the bell-crank lever G⁷ on the shaft G⁸, which is mounted in a bearing *g*³ on the track A'. As shown in Fig. 9, the shaft G⁸ is provided with another arm G⁹, and between said arm and the arm G¹⁰ is 95 a bar G¹¹, supporting a pin G¹², projecting up through an opening in the track A', and is acted upon by the car-wheel, which depresses it, and, as shown in Fig. 4, the arm G² is withdrawn from engagement with the lever 100 E⁴, which is then acted upon by the spring G, and the pin E is depressed.

The switch-tongues and the slot switch-bars are also operated by the pins H and I. 105 As shown in Fig. 7, the pin H is pivoted at *h* to a lever J upon the shaft J'. The pin I is also pivoted to the said lever J at *i*. The said pins project up through openings in the rails and are engaged by the wheels of the car. The shaft J' is mounted in bearings J², 110 Figs. 2 and 6, and is provided with an arm J⁴, which is connected by a rod J³ to an arm J⁶ on the rock-shaft C¹². It will be seen that a movement of either of the pins H or I will operate the said rock-shaft C¹² and the switch-tongues A⁴ and the slot switch-bars B³ and B⁴. As shown in Fig. 1, the plate B³ is provided with a pin B⁶, which acts as a stop and holds the slot switch-bars in their proper positions. 120

The operation of my invention is as follows: The car approaching the switch from the left side of Fig. 1 depresses the pin E¹⁰ by the wheel passing over said pin. This causes the operating-pin E to be raised above the surface 125 of the plates B². The automatic switch-controller upon the car is then set so that it will move the pin E and open the switch, so that the car may pass through in the desired direction. When the car-wheel strikes the pin 130 G¹², the arm G², supporting the operating-pin E, is withdrawn and said operating-pin is depressed, so the top of said pin will be flush with the surface of plates B². As the

mechanism is constructed so as to lock the switch-tongues and slot switch-bars, a car returning through the switch could not open the same, as in the ordinary switch. Therefore the pins H and I are provided, and the wheels of the car returning upon either the main track or the branch track A² and A³ will contact with one of the said pins and operate the switch, so as to open it and allow the car to pass through the same.

Having thus described my invention, I claim and desire to secure by Letters Patent—

1. The combination, in a switch, of the switch-tongues, two slot switch-bars one located at each side of the central slot, and means of throwing one of said slot switch-bars in operation when the switch-tongues are in one position and of throwing the other one of said slot switch-bars in operation when the switch-tongues are in the opposite position, substantially as described.

2. The combination, in a switch, of the switch-tongues, slot switch-bars, vertical shafts, arms on said shafts, links pivoted to said arms and the switch-tongues, links pivoted to said arms and the slot switch-bars and means of operating the said vertical shafts, substantially as described.

3. The combination, in a switch, of the switch-tongues, slot switch-bars, vertical shafts, arms on said shafts, links pivoted to said arms and the switch-tongues, links pivoted to said arms and the slot switch-bars, projections forming hooks on said last-mentioned links adapted to engage the said vertical shafts and lock the switch-tongues and slot switch-bars, substantially as described.

4. The combination, in a switch, of the switch-tongues, slot switch-bars, vertical shafts, arms on said vertical shafts, links pivoted between said arms and said switch-tongues, links pivoted between said arms and said slot switch-bars, a lever on each of said vertical shafts, a rod connected to each of said levers, a rock-shaft, and a lever on said rock-shaft adapted to impart motion through said rods to said vertical shafts, substantially as described.

5. The combination in a switch, of switch-tongues, slot switch-bars, a rock-shaft, vertical shafts, means of communicating motion from said rock-shaft to said vertical shafts, links pivoted to said vertical shafts and to said switch-tongues, and links pivoted to said vertical shafts and to said slot switch-bars, substantially as described.

6. The combination, in a switch of slot switch-bars, a rock-shaft, vertical shafts, means of communicating motion from said rock-shaft to said vertical shafts, links pivoted to said vertical shafts and to the slot switch-bars, substantially as described.

7. The combination, in a switch, of slot switch-bars, a rock-shaft, vertical shafts, means of communicating motion from said rock-shaft to said vertical shafts, links piv-

oted to said vertical shafts and to the slot switch-bars, links pivoted to said vertical shafts and to the switch-tongues, rods pivoted to said vertical shafts and to said rock-shaft, a weight adapted to act upon said rock-shaft, an operating-pin and means of communicating motion from said operating-pin to said rock-shaft, substantially as described.

8. The combination, in a switch, of an operating-pin, means of communicating motion from said operating-pin to the switch, a pin located in the track adapted to be depressed by the car-wheel and thereby raise the operating-pin above the top surface of the switch, and a pin located in the track adapted to be depressed by the car-wheel and depress the operating-pin, substantially as described.

9. The combination, in a switch, of an operating-pin, a disk carrying the same, levers engaging said pin, a shaft carrying said levers, an arm having a notch engaging one of said levers to lock said pin in the raised position, a shaft carrying said arm, a spring to hold said arm and lever in engagement, a pin adapted to act upon the levers carrying the operating-pin, a pin adapted to act upon the notched arm and release the levers carrying the operating-pin and means of communicating motion from the operating-pin to the switch, substantially as described.

10. The combination, in a switch, of an operating-pin, an arm, a rod pivoted to said operating-pin and arm, a shaft carrying said arm, an arm on the opposite end of said shaft, a rock-shaft, a rod and arms connecting the said first-mentioned shaft and rock-shaft, and means of communicating motion from the said rock-shaft to the switch-tongues and slot switch-bars to operate the the same substantially as described.

11. The combination, in a switch, of an operating-pin, a disk, levers to raise and depress said operating-pin, a pin to raise said operating-pin, and a pin to depress said operating-pin, an arm and shaft connected to said operating-pin by a rod, or rock-shaft connected to the last-mentioned shaft by arms and a rod, a lever on said rock-shaft, a weight acting upon one end of said lever, a lever pivoted to the last-mentioned lever, rods connected to the same, arms upon vertical shafts, vertical shafts, arms on the latter, links pivoted to said arms, switch-tongues and slot switch-bars to which said links are pivoted, substantially as described.

12. The combination, in a switch, of a pin located in the main track, a pin located in the branch track, a lever to which said pins are pivoted, a shaft carrying said lever, an arm on said shaft, a rod pivoted to said arm, an arm, a rock-shaft carrying said arm, and means of communicating motion from said rock-shaft to the switch-tongues and slot switch-bars, substantially as described.

13. The combination, in a switch, of a pin located in the main track, a pin located in the branch track, a lever to which said pins are

pivoted, a shaft carrying said lever, an arm on said shaft, a rod pivoted to said arm, an arm, a rock-shaft carrying said arm, a lever on said rock-shaft, a weight to act upon one
 5 end of said last-mentioned lever, a lever carried by the opposite end of said last-mentioned lever, rods pivoted thereto, vertical shafts, said rods pivoted to levers on said vertical shafts, arms on said vertical shafts, links pivoted thereto, switch-tongues and slot switch-
 10 bars, substantially as described.

14. The combination, in a switch, of an operating-pin, a disk, levers to raise and depress said operating-pin, a pin to raise said operating-pin, and a pin to depress said operating-pin, an arm and shaft connected to said operating-pin by a rod, or rock-shaft connected to the last-mentioned shaft by arms and a rod, a pin located in the main track, a pin located

in the branch track, a lever to which said pins 20 are pivoted, a shaft carrying said lever, an arm on said shaft, a rod pivoted thereto, an arm on the said rock-shaft, a lever on said rock-shaft, a weight acting upon one end of said lever, a lever pivoted to the last-men- 25 tioned lever, rods connected to the same, arms upon vertical shafts, vertical shafts, arms on the latter, links pivoted to said arms, switch-tongues and slot switch-bars to which said links are pivoted, substantially as de- 30 scribed.

In testimony whereof I affix my signature in presence of two witnesses.

ISAAC BELL RITTER.

Witnesses:

E. D. PATTERSON,
 W. A. NEWMAN DORLAND.