



(11) **EP 2 495 203 B1**

(12) **EUROPEAN PATENT SPECIFICATION**

(45) Date of publication and mention of the grant of the patent:  
**03.09.2014 Bulletin 2014/36**

(51) Int Cl.:  
**B65H 54/71** <sup>(2006.01)</sup> **B65H 54/88** <sup>(2006.01)</sup>  
**B65H 57/16** <sup>(2006.01)</sup> **B65H 67/048** <sup>(2006.01)</sup>

(21) Application number: **12156825.7**

(22) Date of filing: **24.02.2012**

(54) **Combination of a yarn cutting-sucking device and a yarn regulating guide and spinning winder**

Kombination aus einer Garnschneide-/Garnsaugvorrichtung und einem Fadenführer und Spinnaufwickler

Combinaison d'un dispositif d'aspiration-découpe de fils et d'un guide-fil et enrouleur de filature

(84) Designated Contracting States:  
**AL AT BE BG CH CY CZ DE DK EE ES FI FR GB GR HR HU IE IS IT LI LT LU LV MC MK MT NL NO PL PT RO RS SE SI SK SM TR**

(30) Priority: **01.03.2011 JP 2011043514**

(43) Date of publication of application:  
**05.09.2012 Bulletin 2012/36**

(73) Proprietor: **TMT Machinery, Inc.**  
**Osaka-shi, Osaka 541-0041 (JP)**

(72) Inventors:  
• **Hashimoto, Kinzo**  
**Kyoto, 612-8686 (JP)**

• **Kishine, Akinori**  
**Kyoto, 612-8686 (JP)**

(74) Representative: **HOFFMANN EITLE**  
**Patent- und Rechtsanwälte**  
**Arabellastrasse 4**  
**81925 München (DE)**

(56) References cited:  
**GB-A- 2 152 084 JP-A- 1 045 810**  
**JP-A- 49 071 207 JP-B- 49 002 364**  
**US-A- 3 807 270 US-A- 3 823 631**  
**US-A- 4 023 741 US-A- 4 496 109**

**EP 2 495 203 B1**

Note: Within nine months of the publication of the mention of the grant of the European patent in the European Patent Bulletin, any person may give notice to the European Patent Office of opposition to that patent, in accordance with the Implementing Regulations. Notice of opposition shall not be deemed to have been filed until the opposition fee has been paid. (Art. 99(1) European Patent Convention).

## Description

### BACKGROUND OF THE INVENTION

**[0001]** The present invention relates to a combination of a yarn cutting-sucking device and a yarn regulating guide as well as a spinning winder.

**[0002]** For example, in a machine such as a spinning winder winding a plurality of spun yarns which processes a plurality of yarns continuously supplied and aligned in one direction, the supply of the spun yarns continues even after the interruption of the process. The machine is therefore provided with a yarn cutting-sucking device that cuts and sucks the continuously supplied yarns and retains the yarns during the interruption of the process on the downstream side. As a device for cutting and sucking yarns, the yarn cutting-sucking device of Patent Literature 1 (Japanese Examined Patent Publication No. 7-26247 (Fig. 2(b))) gathers the yarns from the both sides in the alignment directions to the center by a yarn gathering plate, and hangs the yarns altogether on a yarn deposit guide. At the center in the alignment directions are provided a yarn cutter and a yarn sucking unit. The yarns hanged on the yarn deposit guide are guided to a position where the yarn cutter is able to cut them, are cut altogether by the yarn cutter, and are sucked by the yarn sucking unit.

**[0003]** The yarn cutting-sucking device of Patent Literature 1, however, may fail to cut the yarns because the yarns are cut altogether in the form of a thick yarn bundle. Furthermore, even if all yarns are successfully cut altogether, sucking these yarns at once may be unsuccessful.

**[0004]** US 4 023 741 A is related to a yarn cutting-sucking device for cutting and sucking yarns having a movable cutter and sucking unit. Similar devices are derivable from GB 2 152 084 A and US 4,496,109 A.

**[0005]** US 3,807,270 A is related to a similar device employed in a draw-spin-winding machine. This is also the case for JP 01 045810 A.

### SUMMARY OF THE INVENTION

**[0006]** An object of the present invention is therefore to provide a combination of a yarn cutting-sucking device and a yarn regulating guide as well as a spinning winder, which make it possible to certainly cut and suck all yarns irrespective of the number of the yarns.

**[0007]** This object is achieved by a combination of a yarn cutting-sucking device and a yarn regulating guide according to claim 1 and a spinning winder according to claim 5.

**[0008]** The yarn cutting-sucking device of the combination according to the present invention for cutting and sucking a plurality of yarns running and aligned in one direction includes: a cutter arranged to be movable in alignment directions of the plurality of yarns; and a sucking unit arranged to be movable in the alignment direc-

tions in the same manner as the cutter and arranged to suck the plurality of yarns cut by the cutter, the cutter and the sucking unit being moved in an alignment direction while the plurality of yarns are aligned.

**[0009]** The yarn cutting-sucking device of the present invention makes it possible to certainly cut the yarns one by one by moving the cutter in the alignment directions of the yarns. All yarns are therefore certainly cut irrespective of the number of the yarns. Furthermore, as the movement of the sucking unit follows the movement of the cutter, the yarns cut by the cutter are immediately sucked. In this regard, if at least one of the yarns has already been sucked by the sucking unit, the yarns cut thereafter are easily sucked thanks to an accompanied flow which is generated by the running of the yarn having already been sucked and flows toward the sucking unit.

**[0010]** In addition to the above, on the downstream of the cutter in the running direction of the plurality of yarns is provided the yarn regulating guide shaped like comb teeth and constituted by a plurality of grooves aligned in the alignment directions to correspond to the plurality of yarns.

**[0011]** According to this arrangement, since the movement of the running yarns on the downstream of the cutter is regulated in the alignment directions by the yarn regulating guide, the parts of the yarns to be cut by the cutter do not easily move in the movement direction of the cutter. This further ensures the successful cutting of the yarns.

**[0012]** In addition to the above, the yarn cutting-sucking device is preferably arranged so that the sucking unit includes a movable body which has a suction port and is arranged to be movable in the alignment directions, the cutter is attached to the movable body and is arranged to be movable in the alignment directions together with the movable body, and a driving unit arranged to move the movable body in the alignment directions is further provided.

**[0013]** According to this arrangement, by moving the movable body by the driving unit, it is possible to move the cutter and the suction port formed on the movable body altogether while keeping the cutter and the suction port to be in proximity to each other.

**[0014]** In addition to the above, the yarn cutting-sucking device is preferably arranged so that a leading end of the cutter is inclined toward the upstream in a running direction of the yarns with respect to the alignment directions.

**[0015]** According to this arrangement, since the blade part of the cutter is inclined toward the running direction of the yarns, the successful cutting of the running yarns is further ensured.

**[0016]** In addition to the above, the yarn cutting-sucking device is preferably arranged so that the sucking unit is provided on the upstream of the cutter in the running direction of the yarns.

**[0017]** This further ensures the successful sucking of the yarns having been cut by the cutter and on the up-

stream in the running direction.

**[0018]** A spinning winder of the present invention, in which a plurality of melt spinning yarn from a spinning unit are transported via a godet roller and wound by a winding section, is arranged so that the above-described combination of a yarn cutting-sucking device and a yarn regulating guide is provided between the spinning unit and the godet roller.

**[0019]** According to the spinning winder of the present invention, since the melt spinning yarns fused and spun out from the spinning unit are cut and sucked on the upstream of the godet roller in the running direction of the yarns, the threading on the godet roller and winder which are on the downstream is easily done.

**[0020]** It is possible to certainly cut the yarns one by one by moving the cutter in the alignment directions of the yarns, without bending the yarns. All yarns are therefore certainly cut irrespective of the number of the yarns. Furthermore, as the movement of the sucking unit follows the movement of the cutter, the yarns cut by the cutter are immediately sucked. The sucking is easily done because the yarns are not bended. In this regard, if at least one of the yarns has already been sucked by the sucking unit, the yarns cut thereafter are easily sucked thanks to an accompanied flow which is generated by the running of the yarn having already been sucked and flows toward the sucking unit.

#### BRIEF DESCRIPTION OF THE DRAWINGS

##### **[0021]**

Fig. 1 is a profile that outlines a spinning winder.

Fig. 2 is a perspective view of the yarn regulating guide and the yarn cutting-sucking device.

Fig. 3 is a vertical cross section of the yarn regulating guide and the yarn cutting-sucking device at around their leading ends.

Fig. 4 is an enlarged perspective view of the leading end of the yarn cutting-sucking device of Fig. 2.

Fig. 5 illustrates the operation to cut and suck yarns by the yarn cutting-sucking device.

Fig. 6 relates to a modification 1 and is equivalent to Fig. 2.

Fig. 7(a) illustrates a modification 2 and is a plan view.

Fig. 7 (b) illustrates a modification 2 and is a top view.

#### DESCRIPTION OF THE PREFERRED EMBODIMENTS

**[0022]** Now, an embodiment of the present invention will be described. Fig. 1 is a profile that outlines a spinning winder. As shown in Fig. 1, the spinning winder 10 splays, by using a oiling nozzle 2, oil onto yarns Y each made up of filaments ejected from a spinneret 1a of a spinning machine 1 provided at an upper part, draws the yarns Y by using two godet rollers 4a and 4b, transports the yarns Y to the yarn winder 5 provided at a lower part, and winds

the yarns Y.

**[0023]** The spinneret 1a of the spinning machine 1 ejects a plurality of yarns Y each made up of a plurality of filaments. These yarns Y run while being aligned in directions orthogonal to the plane of Fig. 1 (hereinafter, alignment directions). The oiling nozzle 2 sprays oil onto the yarns Y each supplied from the spinning machine 1 and made up of a plurality of filaments.

**[0024]** The godet roller 4a is paired with a separate roller 6a above, whereas the godet roller 4b is paired with a separate roller 6b below. The two godet rollers 4a and 4b are drive rollers driven by an unillustrated drive motor, whereas the two separate rollers 6a and 6b are driven rollers rotated in accordance with the movement of the yarns Y.

**[0025]** On the yarn path on which the yarns Y run, a yarn regulating guide 30 is provided between the oiling nozzle 2 and the godet roller 4a to regulate the movement of the yarns in the alignment directions. Fig. 2 is a perspective view of the yarn regulating guide and the yarn cutting-sucking device. Fig. 3 is a vertical cross section of the yarn regulating guide and the yarn cutting-sucking device at around the leading ends thereof. Fig. 4 is an enlarged perspective view of the leading end of the yarn cutting-sucking device of Fig. 2. As shown in Fig. 2 to Fig. 4, the yarn regulating guide 30 is shaped like comb teeth constituted by a plurality of grooves 30a which are aligned in the alignment directions to correspond to the respective yarns Y. The intervals of the grooves 30a determine the intervals of the yarns Y wound onto the godet rollers 4a and 4b.

**[0026]** At a side of the yarn regulating guide 30 in the alignment directions (i.e., right side of Fig. 2) is provided a yarn cutting-sucking device 40. The yarn cutting-sucking device 40 includes components such as a sucking unit 41 arranged to suck the yarns Y, a sucking power source 42 arranged to drive the sucking unit 41, a cutter 43 for cutting the yarns, and a cylinder 46 for moving a later-described sucking pipe 45 of the sucking unit 41 in the alignment directions.

**[0027]** The sucking unit 41 is connected to the sucking power source 42 and includes a cylindrical member 44 having an axis extending in parallel to the alignment directions of the yarns Y and a sucking pipe 45 which is connected to the inside of the cylindrical member 44 to be movable along the longitudinal directions of the cylindrical member 44. The cylindrical member 44 is attached to a holder 49 which is supported by an unillustrated base, and the sucking pipe 45 is arranged to be movable in the holder 49 in alignment directions. At a leading end of the sucking pipe 45 in the alignment directions, which end is on the far side from the cylindrical member 44, is formed a suction port 45a.

**[0028]** In addition to the above, the cylinder 46 extends along the alignment directions of the yarns Y and is attached to the holder 49, and a leading end of the cylinder rod 46a is connected to a connection member 47 which is attached to the lower surface of the sucking pipe 45.

As the cylinder 46 is driven to move the cylinder rod 46a forward or backward, the sucking pipe 45 move in an alignment direction.

**[0029]** The cutter 43 includes a blade part 50 for cutting yarns Y, a blade part supporter 51 that supports the blade part 50 and is connected to the lower surface of the sucking pipe 45, and an entrapping unit 52 for entrapping the yarns Y. The blade part 50 is shaped like a plate and extends in directions orthogonal to the vertical surface which is in parallel to the running direction of the yarns Y (i.e., vertical direction in Fig. 3) and the alignment directions. The leading end of the blade part 50 is inclined toward the upstream of the running direction of the yarns Y. The entrapping unit 52 is provided on the downstream of the blade part 50 (i.e., left side of Fig. 2) in the direction of movement of the sucking pipe 45, and is provided with a notch 52a where the yarns Y are trapped (see Fig. 4). As the yarns Y are trapped by this notch 52a, the blade part 50 is able to easily cut the yarns Y.

**[0030]** The yarns Y supplied from the spinning machine 1 via the oiling nozzle 2 are wound onto the upstream-side godet roller 4a and separate roller 6a several times, are then wound onto the downstream-side godet roller 4b and separate roller 6b several times, and consequently wound by the yarn winder 5.

**[0031]** In this connection, the downstream-side godet roller 4b rotates faster than the upstream-side godet roller 4a. The godet roller 4a is heated to a temperature with which the yarns Y are elongatable (e.g., 90 degrees centigrade), whereas the godet roller 4b is heated to a temperature (e.g., 120 degrees centigrade) higher than that of the godet roller 4a. With this, the yarns Y supplied from the spinning machine 1 are heated by the godet roller 4a to a temperature with which the yarns Y are elongatable, and are then transported to the yarn winder 5 while being drawn by the godet roller 4b.

**[0032]** At this point, because the supply of the yarns Y from the spinning machine 1 continues even after the winding of the yarns Y by the yarn winder 5 is interrupted, it is necessary to cut and suck the yarns Y supplied from the spinning machine 1 at a position upstream of the yarn winder 5. In this regard, in the present embodiment a yarn cutting-sucking device 40 is provided for cutting and sucking the yarns Y at a position immediately above the yarn regulating guide 30 which is on the yarn path on which the yarns Y run and is between the oiling nozzle 2 and the godet roller 4a.

**[0033]** The operation to cut and suck the yarns Y by the yarn cutting-sucking device 40 will be described with reference to Fig. 5. Fig. 5 illustrates the operation to cut and suck yarns by the yarn cutting-sucking device. First, when the yarn winder 5 winds yarns, the connection to the sucking power source 42 is blocked, the sucking unit 41 is turned off, the cylinder rod 46a of the yarn cutting-sucking device 40 is at the rearmost position (see Fig. 2), and the suction port 45a of the sucking pipe 45 and the blade part 50 of the cutter 43 are retracted to a side of the yarns Y in the alignment directions (i.e., retracted

to positions shown in Fig. 3).

**[0034]** The sucking power source 42 in the retracted state is connected to the sucking unit 41 and the cylinder 46 is activated to start the sucking through the suction port 45a of the sucking pipe 45, and the cylinder rod 46a is advanced. Subsequently, as shown in Fig. 5(a), the suction port 45a of the sucking pipe 45 and the blade part 50 of the cutter 43 are moved toward the yarns Y in the alignment direction. As a result, first the yarn Y closest to the blade part 50 in the alignment direction is cut by the blade part 50 and sucked by the suction port 45a.

**[0035]** As the suction port 45a of the sucking pipe 45 and the blade part 50 of the cutter 43 are moved across the yarns Y in the alignment direction, as shown in Fig. 5(b), the yarns Y are cut one by one by the blade part 50 and sucked by the suction port 45a. In this regard, if at least one of the yarns Y has been sucked by the suction port 45a, an accompanied flow is generated in a direction A from the upstream of the running direction of the yarns Y toward the inside of the suction port 45a. With this, a yarn Y cut by the blade part 50 after at least one of the yarns Y has been sucked is easily sucked on account of the accompanied flow generated by the running yarn Y which has already been sucked by the suction port 45a.

**[0036]** Thereafter, as shown in Fig. 5(c), the suction port 45a of the sucking pipe 45 and the blade part 50 of the cutter 43 are moved toward the other side of the yarns Y in the alignment direction for a predetermined stroke, with the result that all yarns Y are sucked into the suction port 45a. Thereafter, after the cylinder 46 is stopped so that the movement of the sucking pipe 45 is stopped, the operator brings an air sucker 55 close to the yarns Y. As shown in Fig. 5(d), after the yarns Y having been cut are sucked by the air sucker 55, the cylinder 46 is driven to move back the cylinder rod 46a, so that the suction port 45a of the sucking pipe 45 and the blade part 50 of the cutter 43 are retracted. At this point, since the sucking pipe 45 having sucked the yarns Y protrudes toward the side where the operator holding the air sucker 55 is in operation, the yarn regulating guide 30 does not obstruct the operation and the yarns Y having been sucked by the sucking pipe 45 are easily transferred to the air sucker 55.

**[0037]** The yarn cutting-sucking device 40 of the present embodiment makes it possible to certainly cut the yarns Y one by one by moving the blade part 50 of the cutter 43 in the alignment direction of the yarn Y, without bending the yarns Y and gathering the yarns Y to one place. All yarns Y are therefore certainly cut irrespective of the number of yarns Y. In this regard, the edge of the blade part 50 is inclined toward the upstream of the running direction of the yarns Y, and this ensures the successful cutting of the running yarn Y.

**[0038]** In addition to the above, since the sucking pipe 45 and the cutter 43 are connected with each other and are moved together in the alignment directions, the suction port 45a of the sucking pipe 45 follows the movement of the blade part 50 of the cutter 43 and sucks the yarns

Y cut by the blade part 50. The sucking is easily done because the yarns Y are not bended. Furthermore, since the suction port 45a of the sucking pipe 45 is provided on the upstream of the blade part 50 of the cutter 43 in the running direction of the yarns Y, the yarns Y having been cut by the blade part 50 and being on the upstream of the blade part 50 in the running direction are certainly sucked.

**[0039]** In addition to the above, since the above-described yarn cutting-sucking device 40 is provided between the spinning machine 1 and the godet roller 4a, it is easy to thread the yarns onto the godet rollers 4a and 4b and the yarn winder 5 which are on the downstream.

**[0040]** Furthermore, since the blade part 50 is moved along the alignment directions and cuts the yarns Y at a position immediately above the yarn regulating guide 30, the movement of the yarns Y running on the downstream of the blade part 50 in the running direction of the yarns Y is regulated in the alignment directions by the yarn regulating guide 30. Since the parts of the yarns Y to be cut by the blade part 50 do not easily move in the directions in which the blade part 50 moves, the successful cutting of the yarns Y is further ensured.

**[0041]** Now, various modifications of the present embodiment will now be described. It is noted that the same components as in the embodiment are denoted by the same reference numerals as in the embodiment, respectively, and the description thereof will be omitted.

**[0042]** While in the present embodiment the cylinder 46 is provided to move the sucking pipe 45 in the alignment directions of the yarns Y and the cutter 43 is moved in the alignment directions with the sucking pipe 45 as the sucking pipe 45 is combined with the cutter 43, the cutter 43 may be arranged, as shown in Fig. 6, to be independent from the sucking pipe 45 and independently movable in the alignment directions and a cylinder 150 for moving the cutter 43 in the alignment directions may additionally be provided (modification 1). In this modification, the cylinder 46 for moving the sucking pipe 45 is synchronized with the cylinder 150 for moving the cutter 43 so that the positional relationship with the blade part 50 is adjusted to be identical between the suction port 45a of the sucking pipe 45 and the cutter 43. With this, the yarns Y are surely cut one by one and sucked.

**[0043]** In addition to the above, while in the present embodiment the mechanism (cylinder 46 in this embodiment) that moves the sucking pipe 45 and the cutter 43 along the alignment directions of the yarns Y is provided on the outer side along the alignment directions of the yarns Y, the sucking pipe 72 may, as shown in Fig. 7 (a) and 7(b), extend in the directions orthogonal to the alignment directions of the yarns Y and attached to the holder 71, and to the leading end face of the holder 71 where the suction port 72a of the sucking pipe 72 protrudes, a cutter 73 may be attached via a supporting member 74 so that the leading end of the cutter 73 extends in the alignment directions of the yarns Y (modification 2). In this modification, the leading end of the cutter 73 is closer

to the yarn Y than the suction port 72a. As the sucking pipe 72 and the holder 71 are moved in the alignment direction of the yarns Y by an unillustrated linear movement mechanism, the yarns Y are cut one by one and sucked. In this modification, since the sucking pipe 72 extends along the directions orthogonal to the alignment directions of the yarns Y, the yarn cutting-sucking device 40 is downsized as compared to the layout shown in Fig. 2.

**[0044]** In addition to the above, while in the present embodiment the sucking power source 42 and the cutter 43 are moved along the alignment directions by the cylinder 46, an unillustrated guide rail for moving the sucking power source 42 and the cutter 43 in the alignment directions may be provided instead of the cylinder 46, and an operator may move the sucking power source 42 and the cutter 43 along the alignment directions.

**[0045]** In addition to the above, while in the present embodiment the leading end of the blade part 50 of the cutter 43 is inclined toward the upstream of the running direction of the yarns Y, the inclination with respect to the horizontal plane may be differently arranged in accordance with the running speed of the yarns Y. Furthermore, provided that the yarns Y are made of a material that is easy to cut, the leading end of the blade part 50 may be arranged to be in parallel to the horizontal directions without being inclined toward the upstream of the running direction.

**[0046]** While in the present embodiment the yarn cutting-sucking device 40 is provided between the spinning machine 1 and the godet roller 4a, the device 40 may be provided at a different position.

## Claims

### 1. A combination of

1) A yarn cutting-sucking device (40) for cutting and sucking a plurality of yarns (Y) running and aligned in one direction, comprising:

a cutter (43) arranged to be movable in alignment directions of the plurality of yarns (Y); and  
a sucking unit (41) arranged to be movable in the alignment directions in the same manner as the cutter (43) and arranged to suck the plurality of yarns (Y) cut by the cutter (43), and

2) a yarn regulating guide (30) **characterised in that** the yarn regulating guide (30) is provided downstream of the cutter (43) in the running direction of the plurality of yarns (Y), is shaped like comb teeth and constituted by a plurality of grooves aligned in the alignment directions to correspond to the plurality of yarns (Y) and reg-

ulates the movement of the yarns (Y) in the alignment directions;

the cutter (43) and the sucking unit (41) being moved in an alignment direction while the plurality of yarns (Y) are aligned so as to cut the yarns (Y) at a position immediately above the yarn regulating guide (30).

2. The combination according to claim 1, wherein, the sucking unit (41) includes a movable body (45) which has a suction port (45a) and is arranged to be movable in the alignment directions, the cutter (43) is attached to the movable body (45) and is arranged to be movable in the alignment directions together with the movable body (45), and a driving unit (46) arranged to move the movable body (45) in the alignment directions is further provided.
3. The combination according to claim 1 or 2, wherein, a leading end of the cutter (43) is inclined toward the upstream in a running direction of the yarns (Y) with respect to the alignment directions.
4. The combination according to any one of claims 1 to 3, wherein, the sucking unit (41) is provided on the upstream of the cutter (43) in the running direction of the yarns (Y).
5. A spinning winder (10) in which a plurality of yarns (Y) fused and spun out from a spinning unit (1) are transported via a godet roller (4a, b) and wound by a winding section (5), wherein, the combination according to any one of claims 1 to 4 is provided between the spinning unit (1) and the godet roller (4a, b).

#### Patentansprüche

##### 1. Kombination aus

1) einer Garnschneide- und Ansaugereinrichtung (40) zum Schneiden und Ansaugen mehrerer Garne (Y), die in einer Richtung laufen und ausgerichtet sind, aufweisend:

eine Schneideeinrichtung (43), die eingerichtet ist, um in Ausrichtrichtungen der mehreren Garne (Y) beweglich zu sein; und eine Ansaugereinheit (41), die eingerichtet ist, um in den Ausrichtrichtungen in der gleichen Art und Weise wie die Schneideeinrichtung (43) beweglich zu sein und eingerichtet ist, um die mehreren, von der Schneideeinrichtung (43) geschnittenen Garne (Y), anzusaugen, und

2) einer Garnregulierungsführung (30) **dadurch gekennzeichnet, dass** die Garnregulierungsführung (30) stromabwärts der Schneideeinrichtung (43) in der Laufrichtung der mehreren Garne (Y) vorgesehen ist, wie Zähne eines Kamms geformt ist und aus mehreren in der Laufrichtung ausgerichteten Schlitzten aufgebaut ist, um mit den mehreren Garnen (Y) zu korrespondieren und die Bewegung der Garne (Y) in den Ausrichtrichtungen reguliert; wobei die Schneideeinrichtung (43) und die Ansaugereinheit (41) in einer Ausrichtrichtung bewegt werden, während die mehreren Garne (Y) derart ausgerichtet sind, dass die Garne (Y) an einer Position unmittelbar über der Garnregulierungsführung (30) geschnitten werden.

2. Kombination nach Anspruch 1, wobei, die Ansaugereinheit (41) einen beweglichen Körper (45) umfasst, der eine Ansaugöffnung (45a) aufweist und eingerichtet ist, um in den Ausrichtrichtungen beweglich zu sein, die Schneideeinrichtung (43) an dem beweglichen Körper (45) angebracht ist und eingerichtet ist, um zusammen mit dem beweglichen Körper (45) in den Ausrichtrichtungen beweglich zu sein, und ferner eine Antriebseinheit (46) vorgesehen ist, die eingerichtet ist, um den beweglichen Körper (45) in den Ausrichtrichtungen zu bewegen.
3. Kombination nach Anspruch 1 oder 2, wobei, ein Vorderende der Schneideeinrichtung (43) in Bezug auf die Ausrichtrichtungen stromaufwärts in einer Laufrichtung der Garne (Y) geneigt ist.
4. Kombination nach einem der Ansprüche 1 bis 3, wobei die Ansaugereinheit (41) stromaufwärts der Schneideeinrichtung (43) in der Laufrichtung der Garne (Y) vorgesehen ist.
5. Spinnwickler (10), in dem mehrere Garne (Y), die durch eine Spinnereinheit (1) verbunden und ausgesponnen wurden, mittels einer Galettenrolle (4a, b) transportiert und durch einen Wicklungsabschnitt (5) gewickelt werden, wobei die Kombination gemäß einem der Ansprüche 1 bis 4 zwischen der Spinnereinheit (1) und der Galettenrolle (4a, b) vorgesehen ist.

#### Revendications

##### 1. Combinaison de

1) un dispositif d'aspiration-coupe de fils (40) pour couper et aspirer une pluralité de fils (Y) avançant et alignés dans une direction,

comprenant :

un dispositif de coupe (43) agencé pour être mobile dans des directions d'alignement de la pluralité de fils (Y) ; et  
 une unité d'aspiration (41) agencée pour être mobile dans les directions d'alignement de la même manière que le dispositif de coupe (43) et agencée pour aspirer la pluralité de fils (Y) coupée par le dispositif de coupe (43), et

dications 1 à 4 est disposée entre l'unité de filage (1) et le godet de filage (4a, b).

- 2) un guide de régulation de fil (30) **caractérisé en ce que** le guide de régulation de fil (30) est disposé en aval du dispositif de coupe (43) dans la direction d'avance de la pluralité de fils (Y), est formé comme des dents de peigne et constitué par une pluralité de rainures alignées dans les directions d'alignement pour correspondre à la pluralité de fils (Y) et régule le mouvement des fils (Y) dans les directions d'alignement ; le dispositif de coupe (43) et l'unité d'aspiration (41) étant déplacées dans une direction d'alignement tandis que la pluralité de fils (Y) est alignée de façon à couper les fils (Y) à une position immédiatement au-dessus du guide de régulation de fil (30).
2. Combinaison selon la revendication 1, dans laquelle, l'unité d'aspiration (41) inclut un corps mobile (45) qui a un orifice d'aspiration (45a) et qui est agencé pour être mobile dans les directions d'alignement, le dispositif de coupe (43) est attaché au corps mobile (45) et est agencé pour être mobile dans les directions d'alignement en même temps que le corps mobile (45), et une unité d'entraînement (46) agencée pour déplacer le corps mobile (45) dans les directions d'alignement est en outre prévue.
3. Combinaison selon la revendication 1 ou 2, dans laquelle, une extrémité de tête du dispositif de coupe (43) est inclinée vers l'amont dans une direction d'avance des fils (Y) par rapport aux directions d'alignement.
4. Combinaison selon l'une quelconque des revendications 1 à 3, dans laquelle, l'unité d'aspiration (41) est disposée sur l'amont du dispositif de coupe (43) dans la direction d'avance des fils (Y).
5. Bobinoir de filage (10) dans lequel une pluralité de fils (Y) fusionnés et filés en provenance d'une unité de filage (1) sont transportés via un godet de filage (4a, b) et enroulés par une section d'enroulement (5), dans lequel, la combinaison selon l'une quelconque des reven-

FIG. 1

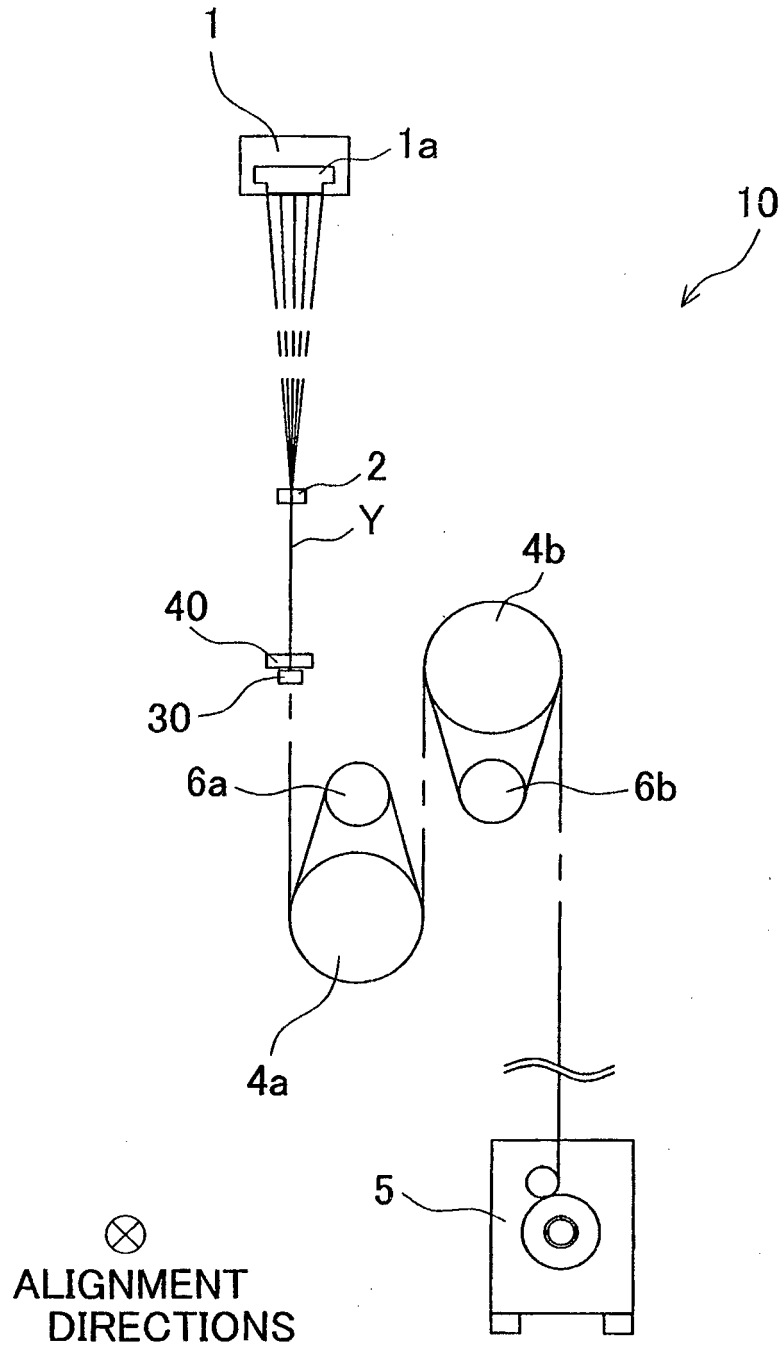



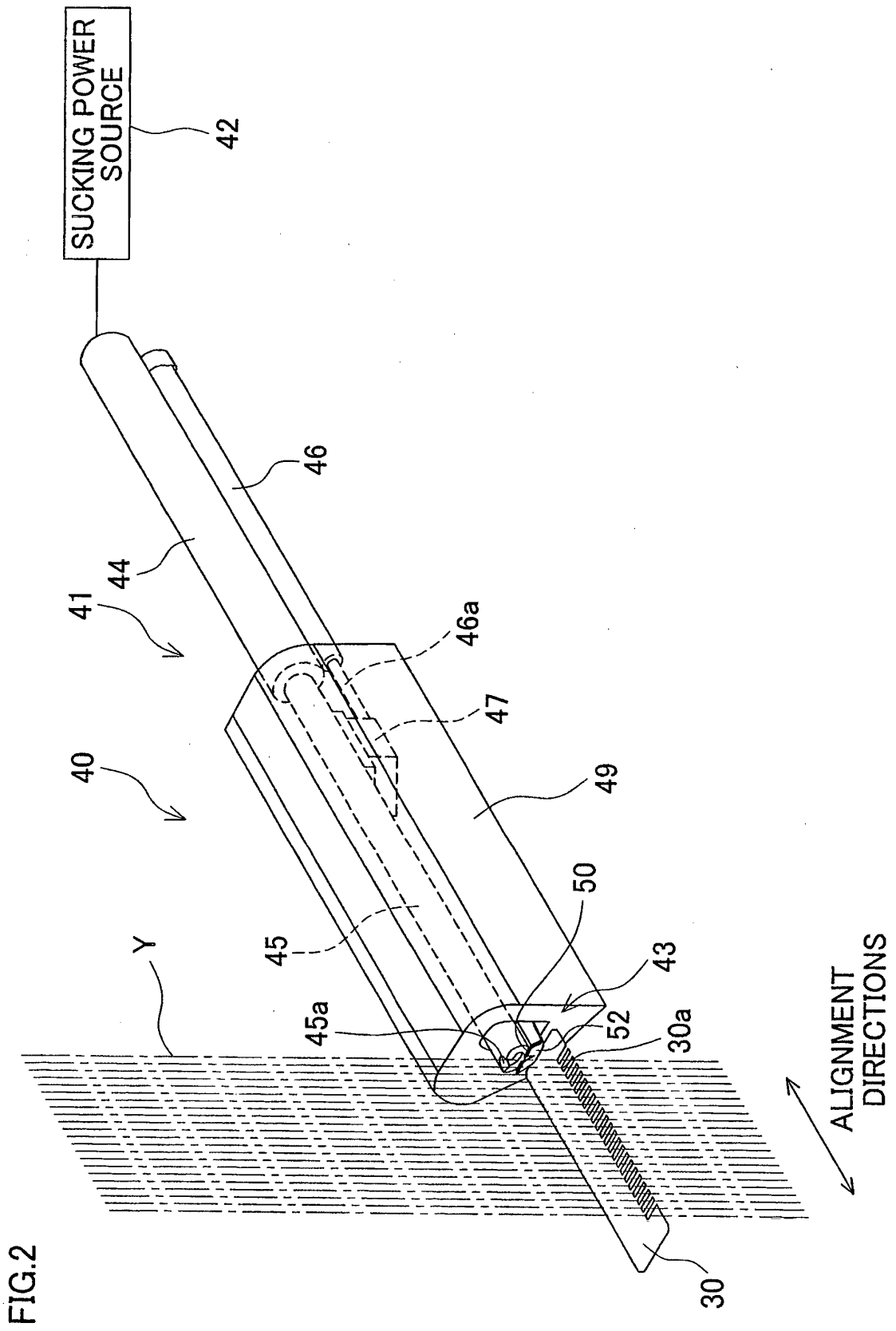

FIG.3

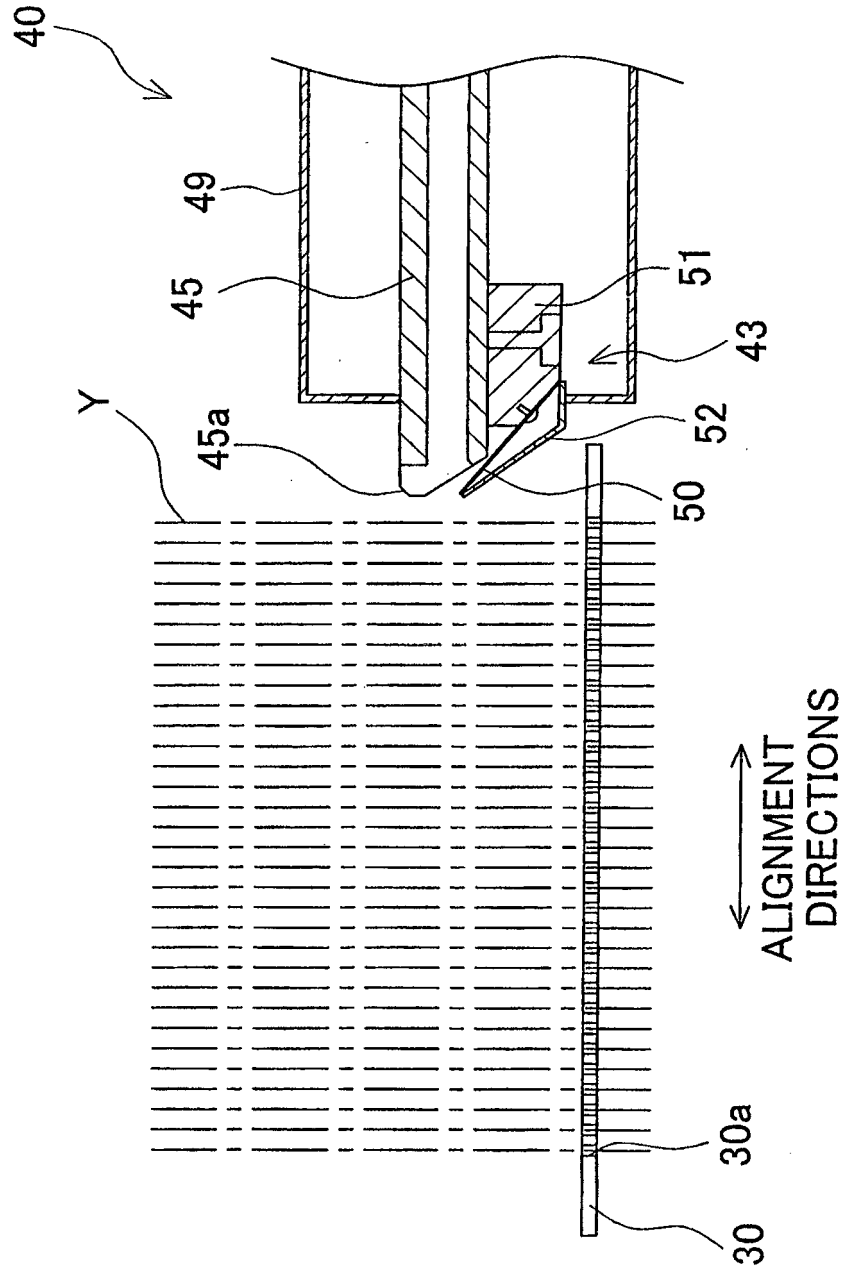
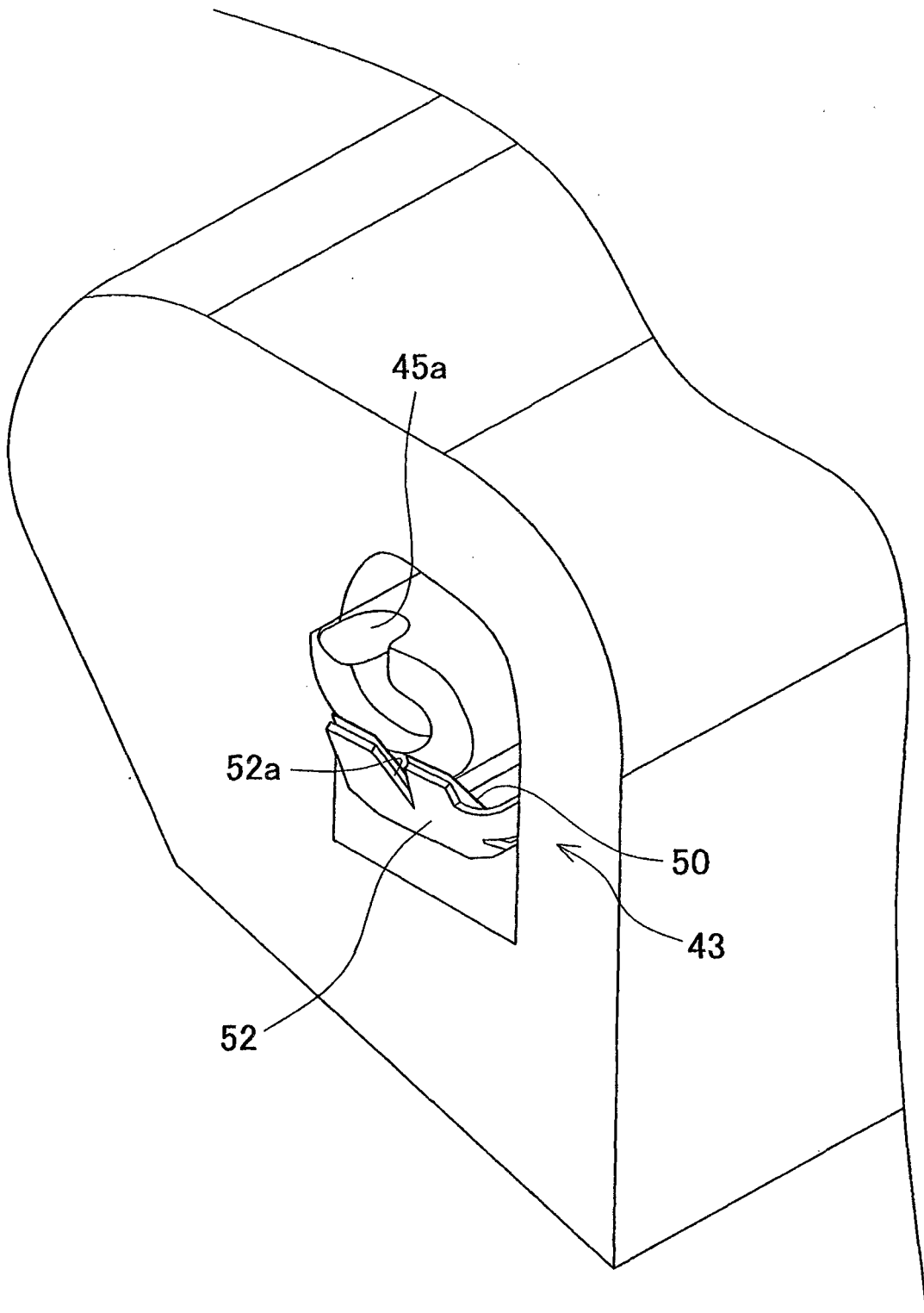
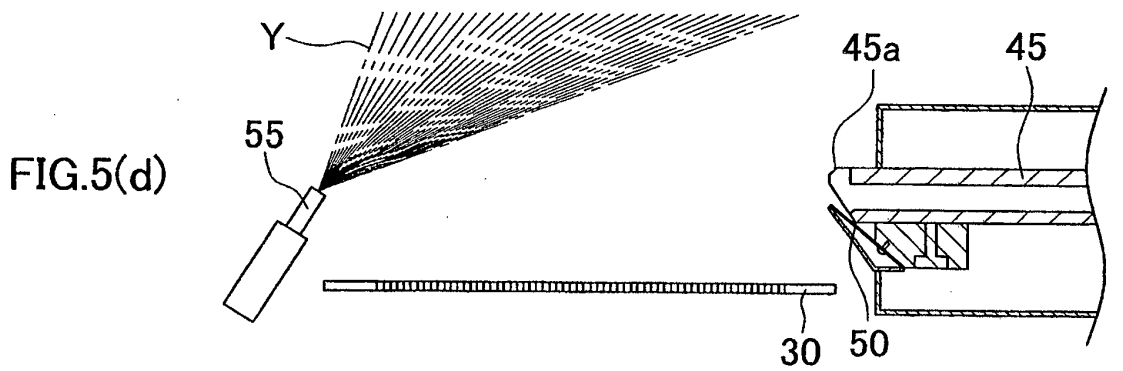
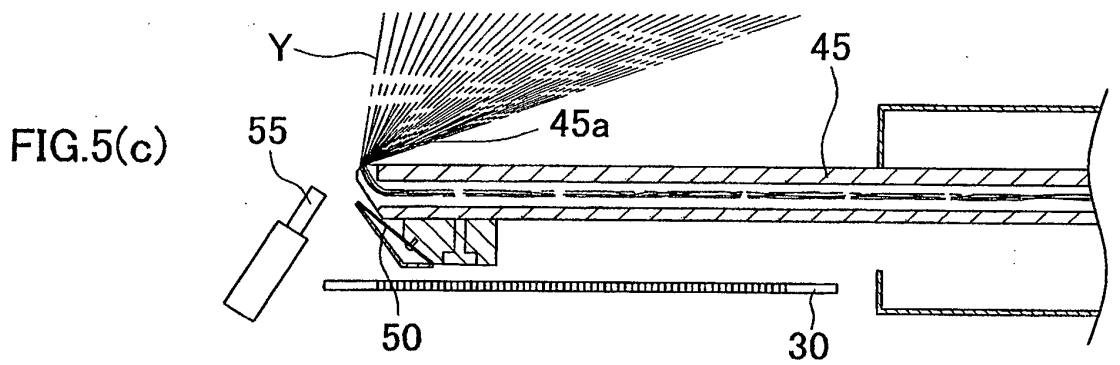
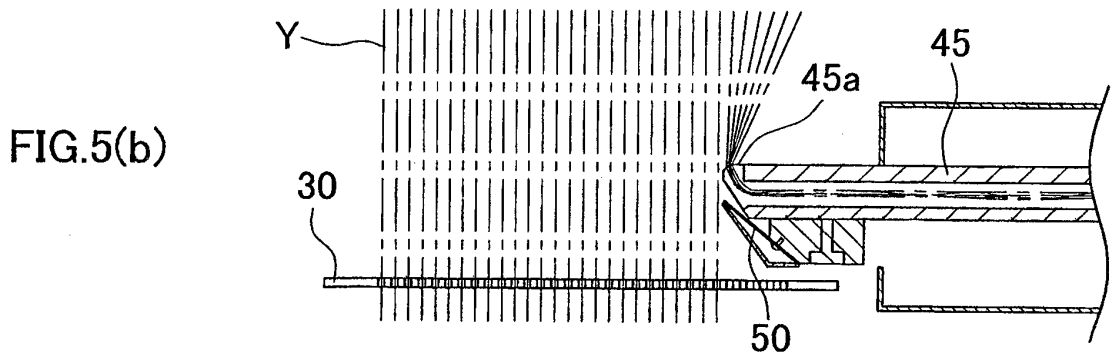
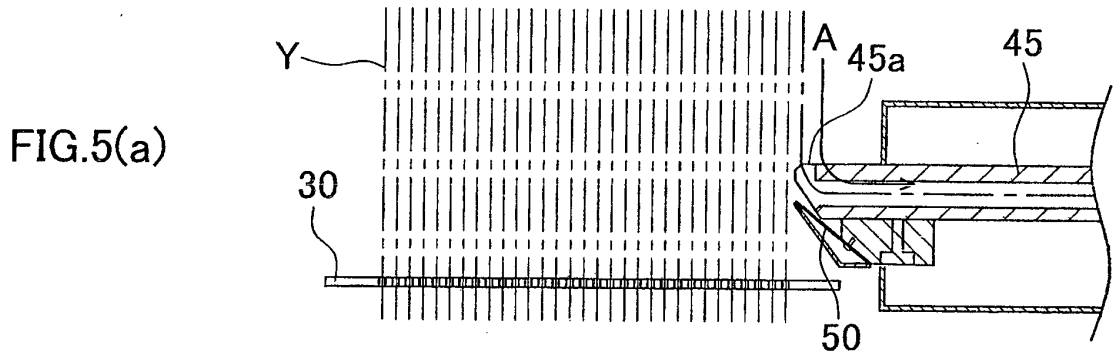
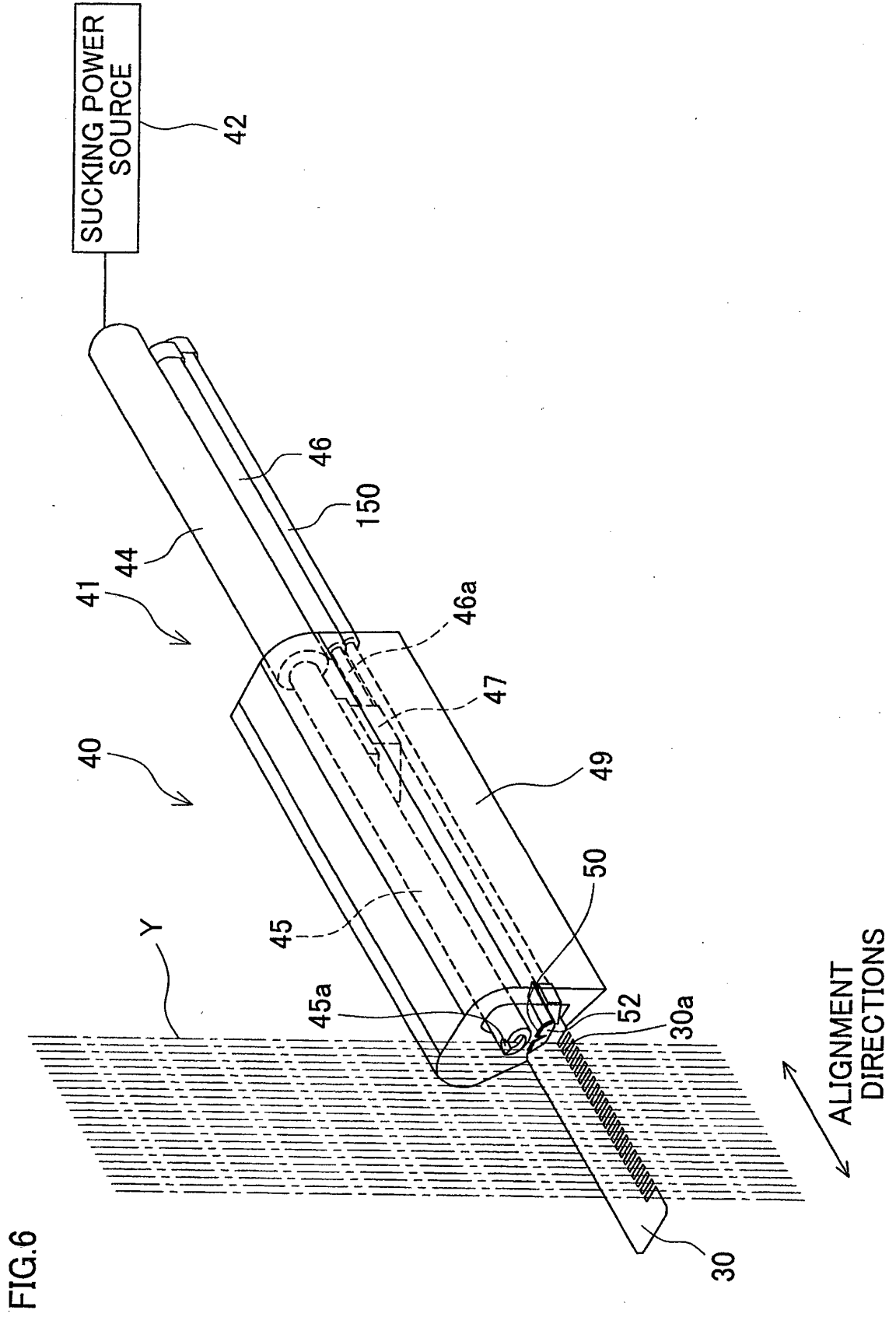

FIG.4







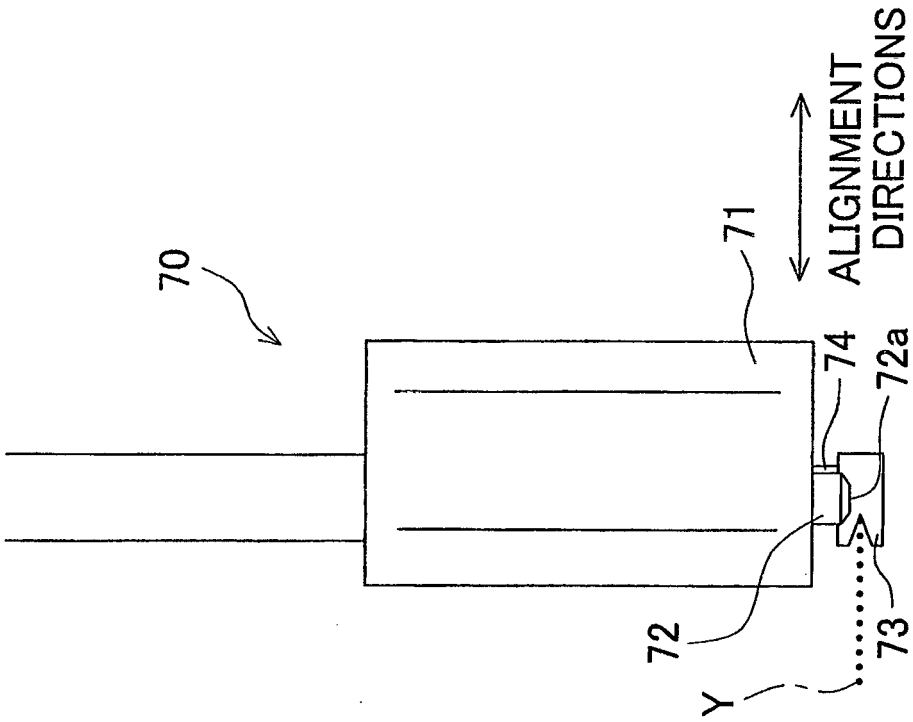

FIG. 7(b)

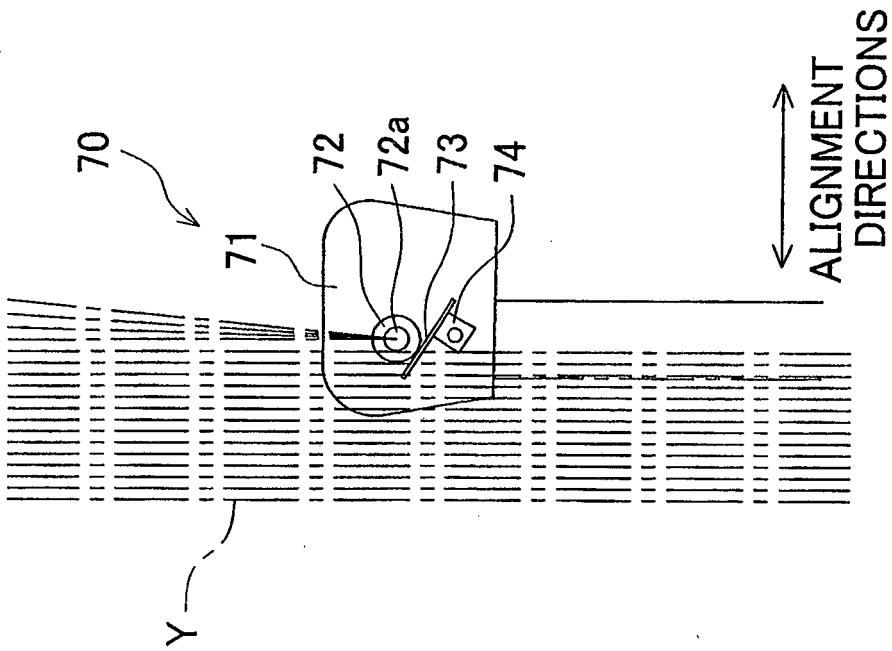

FIG. 7(a)

**REFERENCES CITED IN THE DESCRIPTION**

*This list of references cited by the applicant is for the reader's convenience only. It does not form part of the European patent document. Even though great care has been taken in compiling the references, errors or omissions cannot be excluded and the EPO disclaims all liability in this regard.*

**Patent documents cited in the description**

- JP 7026247 A [0002]
- US 4023741 A [0004]
- GB 2152084 A [0004]
- US 4496109 A [0004]
- US 3807270 A [0005]
- JP 1045810 A [0005]